



FS-1018MFP KM-1815

SERVICE MANUAL

Published in June 2004
842DD112
Revision 2

CAUTION

Danger of explosion if battery is incorrectly replaced. Replace only with the same or equivalent type recommended by the manufacturer. Dispose of used batteries according to the manufacturer's instructions.

CAUTION

Double-pole/neutral fusing.

Revision history

Revision	Date	Replaced pages	Remarks
1	3 June 2004	Contents, 1-1-2, 1-1-3, 1-3-1, 1-3-15, 1-4-2, 1-6-9, 2-4-1, 2-4-2, 2-4-3	-
2	29 June 2004	1-1, 1-2	-

This page is intentionally left blank.





Safety precautions

This booklet provides safety warnings and precautions for our service personnel to ensure the safety of their customers, their machines as well as themselves during maintenance activities. Service personnel are advised to read this booklet carefully to familiarize themselves with the warnings and precautions described here before engaging in maintenance activities.

Safety warnings and precautions

Various symbols are used to protect our service personnel and customers from physical danger and to prevent damage to their property. These symbols are described below:

 **DANGER:** High risk of serious bodily injury or death may result from insufficient attention to or incorrect compliance with warning messages using this symbol.

 **WARNING:** Serious bodily injury or death may result from insufficient attention to or incorrect compliance with warning messages using this symbol.

 **CAUTION:** Bodily injury or damage to property may result from insufficient attention to or incorrect compliance with warning messages using this symbol.

Symbols

The triangle () symbol indicates a warning including danger and caution. The specific point of attention is shown inside the symbol.



General warning.



Warning of risk of electric shock.



Warning of high temperature.

 indicates a prohibited action. The specific prohibition is shown inside the symbol.



General prohibited action.



Disassembly prohibited.

 indicates that action is required. The specific action required is shown inside the symbol.



General action required.



Remove the power plug from the wall outlet.



Always ground the copier.

1. Installation Precautions

WARNING

• Do not use a power supply with a voltage other than that specified. Avoid multiple connections to one outlet: they may cause fire or electric shock. When using an extension cable, always check that it is adequate for the rated current.



• Connect the ground wire to a suitable grounding point. Not grounding the copier may cause fire or electric shock. Connecting the earth wire to an object not approved for the purpose may cause explosion or electric shock. Never connect the ground cable to any of the following: gas pipes, lightning rods, ground cables for telephone lines and water pipes or faucets not approved by the proper authorities.



CAUTION:

• Do not place the copier on an infirm or angled surface: the copier may tip over, causing injury.



• Do not install the copier in a humid or dusty place. This may cause fire or electric shock.



• Do not install the copier near a radiator, heater, other heat source or near flammable material. This may cause fire.



• Allow sufficient space around the copier to allow the ventilation grills to keep the machine as cool as possible. Insufficient ventilation may cause heat buildup and poor copying performance.



• Always handle the machine by the correct locations when moving it.



• Always use anti-toppling and locking devices on copiers so equipped. Failure to do this may cause the copier to move unexpectedly or topple, leading to injury.



• Avoid inhaling toner or developer excessively. Protect the eyes. If toner or developer is accidentally ingested, drink a lot of water to dilute it in the stomach and obtain medical attention immediately. If it gets into the eyes, rinse immediately with copious amounts of water and obtain medical attention.













• Advise customers that they must always follow the safety warnings and precautions in the copier's instruction handbook.







2. Precautions for Maintenance

WARNING

- Always remove the power plug from the wall outlet before starting machine disassembly. 
- Always follow the procedures for maintenance described in the service manual and other related brochures. 
- Under no circumstances attempt to bypass or disable safety features including safety mechanisms and protective circuits. 
- Always use parts having the correct specifications. 
- Always use the thermostat or thermal fuse specified in the service manual or other related brochure when replacing them. Using a piece of wire, for example, could lead to fire or other serious accident. 
- When the service manual or other serious brochure specifies a distance or gap for installation of a part, always use the correct scale and measure carefully. 
- Always check that the copier is correctly connected to an outlet with a ground connection. 
- Check that the power cable covering is free of damage. Check that the power plug is dust-free. If it is dirty, clean it to remove the risk of fire or electric shock. 
- Never attempt to disassemble the optical unit in machines using lasers. Leaking laser light may damage eyesight. 
- Handle the charger sections with care. They are charged to high potentials and may cause electric shock if handled improperly. 

CAUTION

- Wear safe clothing. If wearing loose clothing or accessories such as ties, make sure they are safely secured so they will not be caught in rotating sections. 
- Use utmost caution when working on a powered machine. Keep away from chains and belts. 
- Handle the fixing section with care to avoid burns as it can be extremely hot. 
- Check that the fixing unit thermistor, heat and press rollers are clean. Dirt on them can cause abnormally high temperatures. 
- Do not remove the ozone filter, if any, from the copier except for routine replacement. 

• Do not pull on the AC power cord or connector wires on high-voltage components when removing them; always hold the plug itself.



• Do not route the power cable where it may be stood on or trapped. If necessary, protect it with a cable cover or other appropriate item.



• Treat the ends of the wire carefully when installing a new charger wire to avoid electric leaks.



• Remove toner completely from electronic components.



• Run wire harnesses carefully so that wires will not be trapped or damaged.



• After maintenance, always check that all the parts, screws, connectors and wires that were removed, have been refitted correctly. Special attention should be paid to any forgotten connector, trapped wire and missing screws.



• Check that all the caution labels that should be present on the machine according to the instruction handbook are clean and not peeling. Replace with new ones if necessary.



• Handle greases and solvents with care by following the instructions below:
· Use only a small amount of solvent at a time, being careful not to spill. Wipe spills off completely.
· Ventilate the room well while using grease or solvents.
· Allow applied solvents to evaporate completely before refitting the covers or turning the main switch on.
· Always wash hands afterwards.



• Never dispose of toner or toner bottles in fire. Toner may cause sparks when exposed directly to fire in a furnace, etc.



• Should smoke be seen coming from the copier, remove the power plug from the wall outlet immediately.



3. Miscellaneous

WARNING

• Never attempt to heat the drum or expose it to any organic solvents such as alcohol, other than the specified refiner; it may generate toxic gas.



CONTENTS

1-1 Specifications	
1-1-1 Specifications	1-1-1
1-1-2 Name of parts	1-1-3
(1) Main body	1-1-3
(2) Operation panel	1-1-4
1-2 Handling Precautions	
1-2-1 Drum	1-2-1
1-2-2 Installation environment	1-2-1
1-3 Installation	
1-3-1 Unpacking and installation	1-3-1
(1) Installation procedure	1-3-1
1-3-2 Connecting the cable	1-3-16
1-3-3 Installing the document processor (option)	1-3-18
1-3-4 Installing the expanding memory (option)	1-3-21
1-4 Maintenance Mode	
1-4-1 Maintenance mode	1-4-1
(1) Executing a maintenance item	1-4-1
(2) Maintenance mode item list	1-4-2
(3) Contents of maintenance mode items	1-4-3
1-4-2 System settings	1-4-18
(1) Executing a system setting item	1-4-18
(2) System settings	1-4-19
1-5 Troubleshooting	
1-5-1 Paper misfeed detection	1-5-1
(1) Paper misfeed indication	1-5-1
(2) Paper misfeed detection conditions	1-5-2
(3) Paper misfeeds	1-5-4
1-5-2 Self-diagnosis	1-5-8
(1) Self-diagnostic function	1-5-8
(2) Self-diagnostic codes	1-5-8
1-5-3 Image formation problems	1-5-13
(1) No image appears (entirely white).	1-5-14
(2) No image appears (entirely black).	1-5-14
(3) Image is too light.	1-5-15
(4) Background is visible.	1-5-15
(5) A white line appears longitudinally.	1-5-15
(6) A black line appears longitudinally.	1-5-16
(7) A black line appears laterally.	1-5-16
(8) One side of the print image is darker than the other.	1-5-16
(9) Black dots appear on the image.	1-5-17
(10) Image is blurred.	1-5-17
(11) The leading edge of the image is consistently misaligned with the original.	1-5-17
(12) Paper creases.	1-5-18
(13) Offset occurs.	1-5-18
(14) Image is partly missing.	1-5-18
(15) Fixing is poor.	1-5-19
(16) Image center does not align with the original center.	1-5-19
1-5-4 Electrical problems	1-5-20
(1) The machine does not operate when the power switch is turned on.	1-5-20
(2) The main motor does not operate. (C2000)	1-5-20
(3) The scanner motor does not operate.	1-5-20
(4) Cooling fan does not operate.	1-5-20

(5) The feed clutch does not operate.	1-5-20
(6) The MP feed clutch does not operate.	1-5-21
(7) The registration clutch does not operate.	1-5-21
(8) The eraser lamp does not turn on.	1-5-21
(9) The exposure lamp does not turn on.	1-5-21
(10) The exposure lamp does not turn off.	1-5-21
(11) The heater lamp does not turn on.	1-5-21
(12) The heater lamp does not turn off.	1-5-21
(13) Main charging is not performed.	1-5-22
(14) Transfer charging is not performed.	1-5-22
(15) A paper jam in the paper feed or exit section is indicated when the power switch is turned on.	1-5-22
(16) The message requesting cover to be closed is displayed when the front cover is closed.	1-5-22
(17) Others.	1-5-22
1-5-5 Mechanical problems	1-5-23
(1) No primary paper feed.	1-5-23
(2) No secondary paper feed.	1-5-23
(3) Skewed paper feed.	1-5-23
(4) The scanner does not travel.	1-5-23
(5) Multiple sheets of paper are fed at one time.	1-5-23
(6) Paper jams.	1-5-23
(7) Abnormal noise is heard.	1-5-23

1-6 Assembly and Disassembly

1-6-1 Precautions for assembly and disassembly	1-6-1
(1) Precautions	1-6-1
1-6-2 Removing the process unit	1-6-2
1-6-3 Removing the principal outer covers	1-6-3
(1) Removing the front top cover/face-down output tray	1-6-3
(2) Removing the right cover	1-6-4
(3) Removing the left cover	1-6-4
1-6-4 Removing the feed roller	1-6-5
1-6-5 Removing the MP feed roller	1-6-6
1-6-6 Removing the transfer roller	1-6-8
1-6-7 Removing the principal circuit boards	1-6-9
(1) Removing the engine board	1-6-9
(2) Removing the main board	1-6-10
(3) Removing the power supply board and high voltage board	1-6-12
(4) Removing the bias board	1-6-13
1-6-8 Removing the main motor and drive unit	1-6-14
1-6-9 Removing and splitting the fuser unit	1-6-18
(1) Removing the separation craws	1-6-20
(2) Removing the heater lamp	1-6-21
(3) Removing the heat roller	1-6-22
(4) Removing the thermistor	1-6-24
(5) Removing the thermal cutout	1-6-25
(6) Removing the press roller	1-6-26
1-6-10 Removing and scanner unit	1-6-27
1-6-11 Removing the laser scanner unit and the eraser lamp	1-6-29
1-6-12 Removing the ISU unit	1-6-32
1-6-13 Removing the exposure lamp	1-6-34
1-6-14 Removing the scanner mirror A	1-6-36
1-6-15 Removing the scanner motor	1-6-37
1-6-16 Removing the main charger unit	1-6-40
1-6-17 Adjustment the maintenance mode	1-6-41
(1) Adjusting the leading edge registration of image printing	1-6-41
(2) Adjusting the center line of image printing	1-6-42
(3) Adjusting the amount of slack in the paper	1-6-43

- (4) Adjusting magnification of the scanner in the main scanning direction 1-6-44
- (5) Adjusting magnification of the scanner in the auxiliary scanning direction 1-6-45
- (6) Adjusting the scanner leading edge registration 1-6-46
- (7) Adjusting the scanner center line 1-6-47
- (8) Adjusting the margins for scanning an original on the contact glass 1-6-48
- (9) Adjusting the DP magnification 1-6-49
- (10) Adjusting the DP leading edge registration 1-6-50
- (11) Adjusting the DP trailing edge registration 1-6-51
- (12) Adjusting the DP center line 1-6-52
- (13) Adjusting the margins for scanning the original from the DP 1-6-53

1-7 Requirements on PWB Replacement

- 1-7-1 Upgrading the firmware on the main board 1-7-1

2-1 Mechanical construction

- 2-1-1 Paper feeding system 2-1-1
 - (1) Paper feed control 2-1-2
 - (2) Paper feeding mechanism 2-1-3
- 2-1-2 Original scanning system 2-1-4
 - (1) ISU unit 2-1-6
- 2-1-3 Electrophotographic system 2-1-7
 - (1) Electrophotographic cycle 2-1-7
 - (1-1) Process unit mechanism 2-1-8
 - (2) Main charging 2-1-9
 - (2-1) Photo conductive drum 2-1-9
 - (2-2) Charging the drum 2-1-10
 - (3) Exposure 2-1-11
 - (3-1) Laser scanner unit 2-1-12
 - (3-2) Drum surface potential 2-1-13
 - (4) Development 2-1-14
 - (5) Transfer 2-1-15
 - (6) Fusing 2-1-16
 - (6-1) Fuser unit mechanism 2-1-17
 - (7) Cleaning 2-1-18

2-2 Electrical Parts Layout

- 2-2-1 Electrical parts layout 2-2-1
 - (1) Main unit 2-2-1
 - (2) Scanner unit 2-2-2

2-3 Operation of the PWBs

- 2-3-1 Main board 2-3-1
- 2-3-2 Engine board 2-3-7
 - (1) Eraser lamp control circuit 2-3-9
 - (2) Heater lamp control circuit 2-3-10
 - (3) Polygon motor control circuit 2-3-13
- 2-3-3 Power supply board 2-3-17
- 2-3-4 Bias board 2-3-19
- 2-3-5 High voltage board 2-3-20
 - (1) Interlock switch 2-3-21
- 2-3-6 CCD board 2-3-22
- 2-3-7 Operation board 2-3-24
- 2-3-8 Scanner board 2-3-26

2-4 Appendixes

- Timing chart No. 1 2-4-1
- Timing chart No. 2 2-4-2
- Timing chart No. 3 2-4-3
- Wiring diagram 2-4-4

CONTENTS

1-1 Specifications	
1-1-1 Specifications	1-1-1
1-1-2 Name of parts	1-1-3
(1) Main body	1-1-3
(2) Operation panel	1-1-4
1-2 Handling Precautions	
1-2-1 Drum	1-2-1
1-2-2 Installation environment	1-2-1
1-3 Installation	
1-3-1 Unpacking and installation	1-3-1
(1) Installation procedure	1-3-1
1-3-2 Connecting the cable	1-3-16
1-3-3 Installing the document processor (option)	1-3-18
1-3-4 Installing the expanding memory (option)	1-3-21
1-4 Maintenance Mode	
1-4-1 Maintenance mode	1-4-1
(1) Executing a maintenance item	1-4-1
(2) Maintenance mode item list	1-4-2
(3) Contents of maintenance mode items	1-4-3
1-4-2 System settings	1-4-18
(1) Executing a system setting item	1-4-18
(2) System settings	1-4-19
1-5 Troubleshooting	
1-5-1 Paper misfeed detection	1-5-1
(1) Paper misfeed indication	1-5-1
(2) Paper misfeed detection conditions	1-5-2
(3) Paper misfeeds	1-5-4
1-5-2 Self-diagnosis	1-5-8
(1) Self-diagnostic function	1-5-8
(2) Self-diagnostic codes	1-5-8
1-5-3 Image formation problems	1-5-13
(1) No image appears (entirely white).	1-5-14
(2) No image appears (entirely black).	1-5-14
(3) Image is too light.	1-5-15
(4) Background is visible.	1-5-15
(5) A white line appears longitudinally.	1-5-15
(6) A black line appears longitudinally.	1-5-16
(7) A black line appears laterally.	1-5-16
(8) One side of the print image is darker than the other.	1-5-16
(9) Black dots appear on the image.	1-5-17
(10) Image is blurred.	1-5-17
(11) The leading edge of the image is consistently misaligned with the original.	1-5-17
(12) Paper creases.	1-5-18
(13) Offset occurs.	1-5-18
(14) Image is partly missing.	1-5-18
(15) Fixing is poor.	1-5-19
(16) Image center does not align with the original center.	1-5-19
1-5-4 Electrical problems	1-5-20
(1) The machine does not operate when the power switch is turned on.	1-5-20
(2) The main motor does not operate. (C2000)	1-5-20
(3) The scanner motor does not operate.	1-5-20
(4) Cooling fan does not operate.	1-5-20

(5) The feed clutch does not operate.	1-5-20
(6) The MP feed clutch does not operate.	1-5-21
(7) The registration clutch does not operate.	1-5-21
(8) The eraser lamp does not turn on.	1-5-21
(9) The exposure lamp does not turn on.	1-5-21
(10) The exposure lamp does not turn off.	1-5-21
(11) The heater lamp does not turn on.	1-5-21
(12) The heater lamp does not turn off.	1-5-21
(13) Main charging is not performed.	1-5-22
(14) Transfer charging is not performed.	1-5-22
(15) A paper jam in the paper feed or exit section is indicated when the power switch is turned on.	1-5-22
(16) The message requesting cover to be closed is displayed when the front cover is closed.	1-5-22
(17) Others.	1-5-22
1-5-5 Mechanical problems	1-5-23
(1) No primary paper feed.	1-5-23
(2) No secondary paper feed.	1-5-23
(3) Skewed paper feed.	1-5-23
(4) The scanner does not travel.	1-5-23
(5) Multiple sheets of paper are fed at one time.	1-5-23
(6) Paper jams.	1-5-23
(7) Abnormal noise is heard.	1-5-23

1-6 Assembly and Disassembly

1-6-1 Precautions for assembly and disassembly	1-6-1
(1) Precautions	1-6-1
1-6-2 Removing the process unit	1-6-2
1-6-3 Removing the principal outer covers	1-6-3
(1) Removing the front top cover/face-down output tray	1-6-3
(2) Removing the right cover	1-6-4
(3) Removing the left cover	1-6-4
1-6-4 Removing the feed roller	1-6-5
1-6-5 Removing the MP feed roller	1-6-6
1-6-6 Removing the transfer roller	1-6-8
1-6-7 Removing the principal circuit boards	1-6-9
(1) Removing the engine board	1-6-9
(2) Removing the main board	1-6-10
(3) Removing the power supply board and high voltage board	1-6-12
(4) Removing the bias board	1-6-13
1-6-8 Removing the main motor and drive unit	1-6-14
1-6-9 Removing and splitting the fuser unit	1-6-18
(1) Removing the separation craws	1-6-20
(2) Removing the heater lamp	1-6-21
(3) Removing the heat roller	1-6-22
(4) Removing the thermistor	1-6-24
(5) Removing the thermal cutout	1-6-25
(6) Removing the press roller	1-6-26
1-6-10 Removing and scanner unit	1-6-27
1-6-11 Removing the laser scanner unit and the eraser lamp	1-6-29
1-6-12 Removing the ISU unit	1-6-32
1-6-13 Removing the exposure lamp	1-6-34
1-6-14 Removing the scanner mirror A	1-6-36
1-6-15 Removing the scanner motor	1-6-37
1-6-16 Removing the main charger unit	1-6-40
1-6-17 Adjustment the maintenance mode	1-6-41
(1) Adjusting the leading edge registration of image printing	1-6-41
(2) Adjusting the center line of image printing	1-6-42
(3) Adjusting the amount of slack in the paper	1-6-43

(4) Adjusting magnification of the scanner in the main scanning direction	1-6-44
(5) Adjusting magnification of the scanner in the auxiliary scanning direction	1-6-45
(6) Adjusting the scanner leading edge registration	1-6-46
(7) Adjusting the scanner center line	1-6-47
(8) Adjusting the margins for scanning an original on the contact glass	1-6-48
(9) Adjusting the DP magnification	1-6-49
(10) Adjusting the DP leading edge registration	1-6-50
(11) Adjusting the DP trailing edge registration	1-6-51
(12) Adjusting the DP center line	1-6-52
(13) Adjusting the margins for scanning the original from the DP	1-6-53

1-7 Requirements on PWB Replacement

1-7-1 Upgrading the firmware on the main board	1-7-1
--	-------

2-1 Mechanical construction

2-1-1 Paper feeding system	2-1-1
(1) Paper feed control	2-1-2
(2) Paper feeding mechanism	2-1-3
2-1-2 Original scanning system	2-1-4
(1) ISU unit	2-1-6
2-1-3 Electrophotographic system	2-1-7
(1) Electrophotographic cycle	2-1-7
(1-1) Process unit mechanism	2-1-8
(2) Main charging	2-1-9
(2-1) Photo conductive drum	2-1-9
(2-2) Charging the drum	2-1-10
(3) Exposure	2-1-11
(3-1) Laser scanner unit	2-1-12
(3-2) Drum surface potential	2-1-13
(4) Development	2-1-14
(5) Transfer	2-1-15
(6) Fusing	2-1-16
(6-1) Fuser unit mechanism	2-1-17
(7) Cleaning	2-1-18

2-2 Electrical Parts Layout

2-2-1 Electrical parts layout	2-2-1
(1) Main unit	2-2-1
(2) Scanner unit	2-2-2

2-3 Operation of the PWBs

2-3-1 Main board	2-3-1
2-3-2 Engine board	2-3-7
(1) Eraser lamp control circuit	2-3-9
(2) Heater lamp control circuit	2-3-10
(3) Polygon motor control circuit	2-3-13
2-3-3 Power supply board	2-3-17
2-3-4 Bias board	2-3-19
2-3-5 High voltage board	2-3-20
(1) Interlock switch	2-3-21
2-3-6 CCD board	2-3-22
2-3-7 Operation board	2-3-24
2-3-8 Scanner board	2-3-26

2-4 Appendixes

Timing chart No. 1	2-4-1
Timing chart No. 2	2-4-2
Timing chart No. 3	2-4-3
Wiring diagram	2-4-4

1-1-1 Specifications

Type	Desktop
Copying system	Indirect electrostatic system
Originals	Sheets of paper (Maximum original size: folio/8 ¹ / ₂ " × 14" [legal]) Platen: Sheets of paper, books, 3-dimensional objects (Maximum original size: folio/8 ¹ / ₂ " × 14" [legal])
Original feed system	Contact glass: fixed Document processor (optional): sheet-through
Copy paper	Cassette: Plain paper (60 - 105 g/m ²) MP tray: Plain paper (60 - 163 g/m ²) Special paper: Transparencies, letterhead, colored paper, recycled paper Note: Use the MP tray for special paper.
Copying sizes	Maximum: folio/8 ¹ / ₂ " × 14" [legal] Minimum: A6R /5 ¹ / ₂ " × 8 ¹ / ₂ "
Magnification ratios	Manual mode: 50 - 200%, 1% increments
Copying speed	At 100% magnification, platen: A4/8 ¹ / ₂ " × 11": 18 copies/min. A5: 18 copies/min. 8 ¹ / ₂ " × 14": 15 copies/min. At 100% magnification, document processor: A4/8 ¹ / ₂ " × 11": 18 copies/min.
First copy speed	Apporox. 10 s (A4/8 ¹ / ₂ " × 11", original placed on the platen)
Warm-up time	Within 30 s Recovery from the low power mode: Within 10 s Recovery from the sleep mode: Within 15 s (at room temperature 23°C/73.4°F, humidity 60% RH)
Paper feed system	Cassette: 250 sheets (80 g/m ²) MP tray: 50 sheets (80 g/m ²)
Stacking capacity	Output tray: Approx. 150 sheets (80 g/m ²) Face-up tray: 30 sheets (80 g/m ²)
Standard memory	96 MB (64 MB of system memory and 32 MB of additional memory) (Approx. 70 pages of memory possible with letter size, 5%, Text+Photo mode)
Additional memory	1 slot (64 MB, 128 MB or 256 MB)
Continuous copying	1 - 999 sheets
Scanning system	Flat bed scanning by CCD image sensor
Resolution	Reading (scanning) 600 × 600 dpi Writing (printing) 600 × 600 dpi
Original quality mode	Text+Photo, Photo and Text
Light source	Cold cathode lamp
Photoconductor	OPC (drum diameter 30 mm)
Charging system	Single positive corona charging
Developing system	Single element reversing process
Transfer system	Transfer roller
Fixing system	Heat roller Heat source: halogen heaters (750 W) Control temperature: 190°C/374°F (at normal ambient temperature) Abnormally high temperature protection device: thermal cutout
Charge erasing system	Exposure by cleaning lamp
Cleaning system	Cleaning blade
Dimensions	496 (W) × 421 (D) × 385 (H) mm 19 ⁹ / ₁₆ " (W) × 16 ⁵ / ₈ " (D) × 15 ³ / ₁₆ " (H)
Weight	Approx. 14.5 kg/32.0 lbs
Floor requirements	496 (W) × 740 (D) mm 19 ⁹ / ₁₆ " (W) × 29 ³ / ₁₆ " (D)
Functions	Auto exposure adjustment, Eco-copy mode, Zoom mode, Preset zoom mode, Off mode, Low power mode, Layout modes, Sort mode and Program function
Power source	120 V AC, 60 Hz, 7.8 A 220 - 240 V AC, 50/60 Hz, 4.0 A
Power consumption	854 W
Options	Paper feeder, Document processor and Additional memory

• Printing functions

Printing speed A4/8¹/₂" × 11": 18 prints/min.
A5: 18 prints/min.
8¹/₂" × 14": 15 prints/min.
First print speed Apporox. 8 s (A4/8¹/₂" × 11")
Resolution 300, 600 dpi and Fast 1200
Compatible operation system Microsoft Windows 95/98/Me/NT 4.0/2000/XP
Apple Macintosh OS 9.0/OS X 10.1 to 10.3
Host interface Parallel: 1 port (IEEE1284)
USB: 1 port (Hi-speed USB 2.0)
Ethernet: 1 port (10BASE-T/100BASE-TX)
PDL PRESCRIBE
Emulation mode Line printer, IBM proprinter X24E, DIABLO 630, EPSON LQ-850, PCL6 and KPDL3

• Scanning functions

Scanning speed Monochrome: 18 spm
Full color or Grayscale: 4.8 spm
Resolution 200, 300, 400 and 600 dpi
Color mode Full color, Grayscale and Monochrome
Halftone Full color: 8 bit/dot: each color
Grayscale: 8 bit/dot
Monochrome: 1 bit/dot
Original quality mode Text+Photo, Photo, Text and OCR
File format PDF (All modes), TIFF (only monochrome mode), JPEG (except monochrome mode)
Host interface Ethernet: 1 port (10BASE-T/100BASE-TX)

1-1-2 Names of parts

(1) Main body

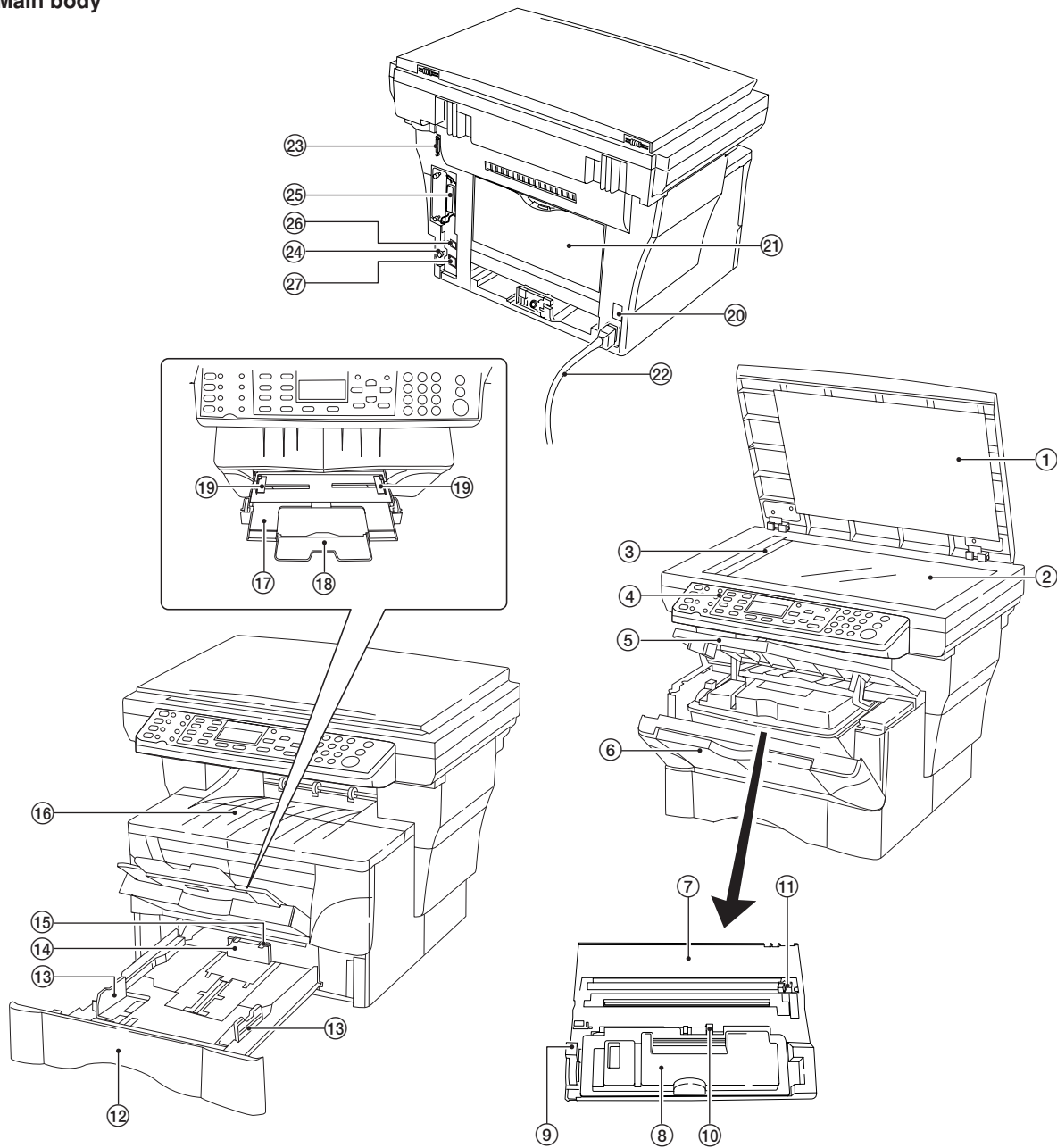

Figure 1-1-1 Names of parts

- | | |
|---------------------------------|--------------------------------|
| ① Original cover | ⑮ Stopper extension lock |
| ② Contact glass | ⑯ Face-down output tray |
| ③ Original size indicator | ⑰ MP tray |
| ④ Operation panel | ⑱ Extension tray |
| ⑤ Front top cover | ⑲ Slider |
| ⑥ Front cover | ⑳ Power switch |
| ⑦ Process unit | ㉑ Face-up output tray |
| ⑧ Toner container | ㉒ Power cord |
| ⑨ Lock lever | ㉓ DP interface connector |
| ⑩ Toner container release lever | ㉔ Memory cover |
| ⑪ Main charger cleaner | ㉕ Parallel interface connector |
| ⑫ Cassette | ㉖ USB interface connector |
| ⑬ Paper guide | ㉗ Network interface connector |
| ⑭ Paper stopper | |

(2) Operation panel

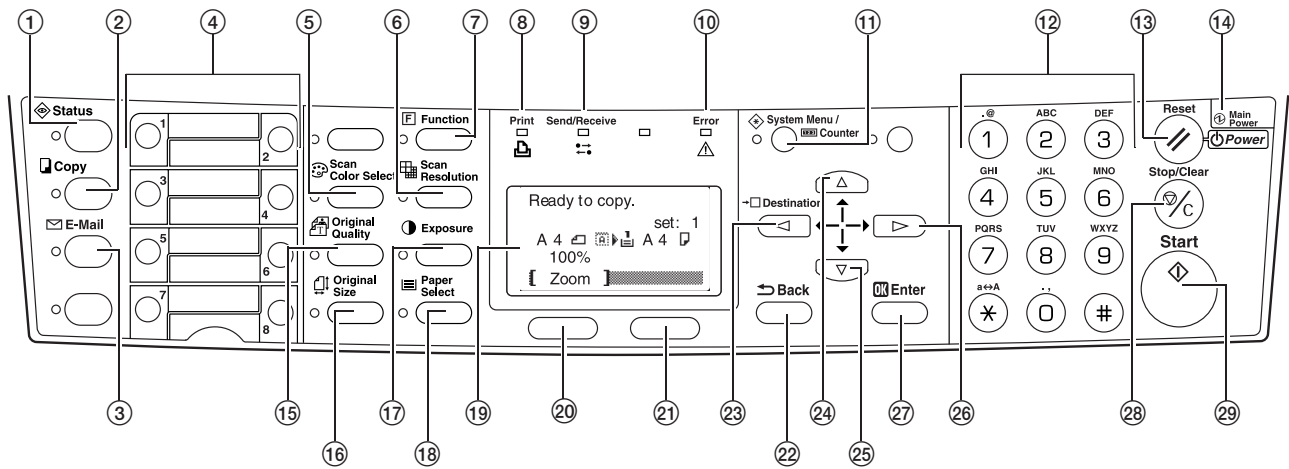

Figure 1-1-2

- | | |
|---|--------------------------------------|
| ① Status key and indicator | ⑮ Original quality key and indicator |
| ② Copy key and indicator | ⑯ Original size key and indicator |
| ③ E-mail (Scan) key and indicator | ⑰ Exposure key and indicator |
| ④ One-touch keys (1 to 8) | ⑱ Paper select key and indicator |
| ⑤ Scan color select key and indicator | ⑲ Message display |
| ⑥ Scan resolution key and indicator | ⑳ Left select key |
| ⑦ Function key and indicator | ㉑ Right select key |
| ⑧ Print indicator | ㉒ Back key |
| ⑨ Send/Receive indicator | ㉓ Left cursor key |
| ⑩ Error indicator | ㉔ Up cursor key |
| ⑪ System menu/Counter key and indicator | ㉕ Down cursor key |
| ⑫ Keypad | ㉖ Right cursor key |
| ⑬ Reset/Power key | ㉗ Enter key |
| ⑭ Main power indicator | ㉘ Stop/Clear key |
| | ㉙ Start key and indicator |

1-2-1 Drum

Note the following when handling or storing the drum.

- When removing the process unit, never expose the drum surface to strong direct light.
- Keep the drum at an ambient temperature between 10°C/50°F and 32.5°C/90.5°F and at a relative humidity not higher than 80% RH. Avoid abrupt changes in temperature and humidity.
- Avoid exposure to any substance which is harmful to or may affect the quality of the drum.
- Do not touch the drum surface with any object. Should it be touched by hands or stained with oil, clean it.

1-2-2 Installation environment

1. Temperature: 10 - 32.5°C/50 - 90.5°F
2. Humidity: 20 - 80%RH
3. Power supply: 120 V AC, 7.8 A
220 - 240 V AC, 4.0 A
4. Power source frequency: 50 Hz \pm 0.3%/60 Hz \pm 0.3%
5. Installation location
 - Avoid direct sunlight or bright lighting. Ensure that the photoconductor will not be exposed to direct sunlight or other strong light when removing paper jams.
 - Avoid extremes of temperature and humidity, abrupt ambient temperature changes, and hot or cold air directed onto the machine.
 - Avoid dust and vibration.
 - Choose a surface capable of supporting the weight of the machine.
 - Place the machine on a level surface (maximum allowance inclination: 1°).
 - Avoid air-borne substances that may adversely affect the machine or degrade the photoconductor, such as mercury, acidic or alkaline vapors, inorganic gasses, NO_x, SO_x gases and chlorine-based organic solvents.
 - Select a room with good ventilation.
6. Allow sufficient access for proper operation and maintenance of the machine.
Machine front: 1000 mm/39³/₈" Machine rear: 300 mm/11¹³/₁₆"
Machine right: 300 mm/11¹³/₁₆" Machine left: 300 mm/11¹³/₁₆"

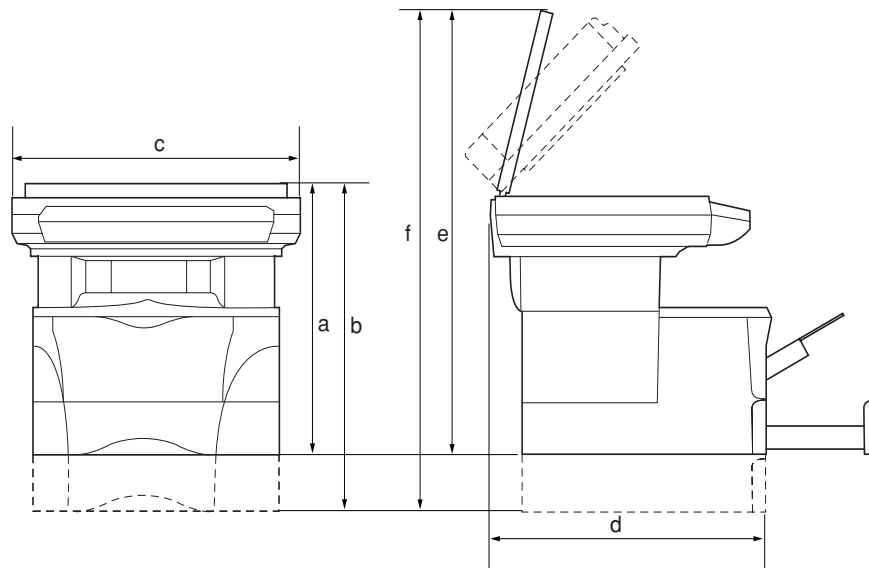

- a: 385 mm/15³/₁₆"
- b: 460 mm/18¹/₈"
- c: 496 mm/19⁹/₁₆"
- d: 421 mm/16⁵/₈"
- e: 665 mm/26³/₁₆"
- f: 740 mm/29³/₁₆"

Figure 1-2-1 Installation dimensions

1-3-1 Unpacking and installation

(1) Installation procedure

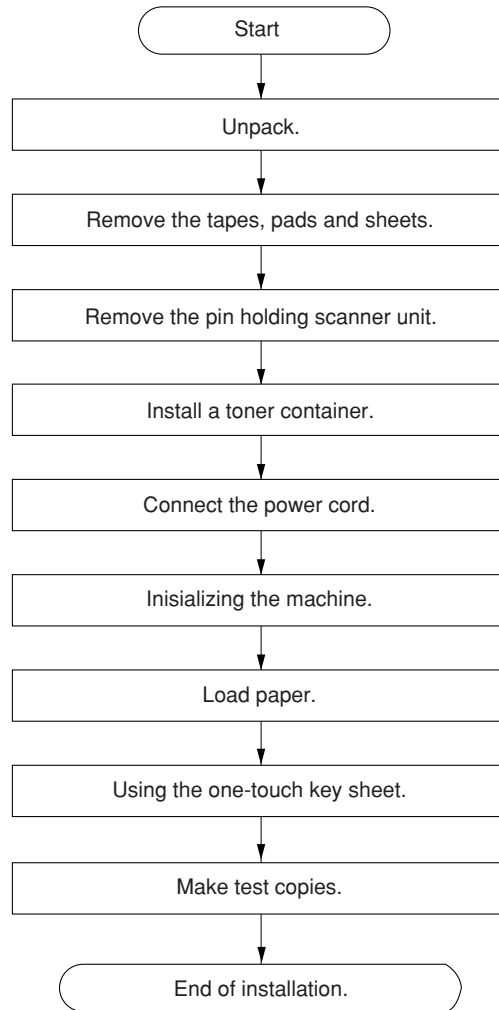

Unpack.

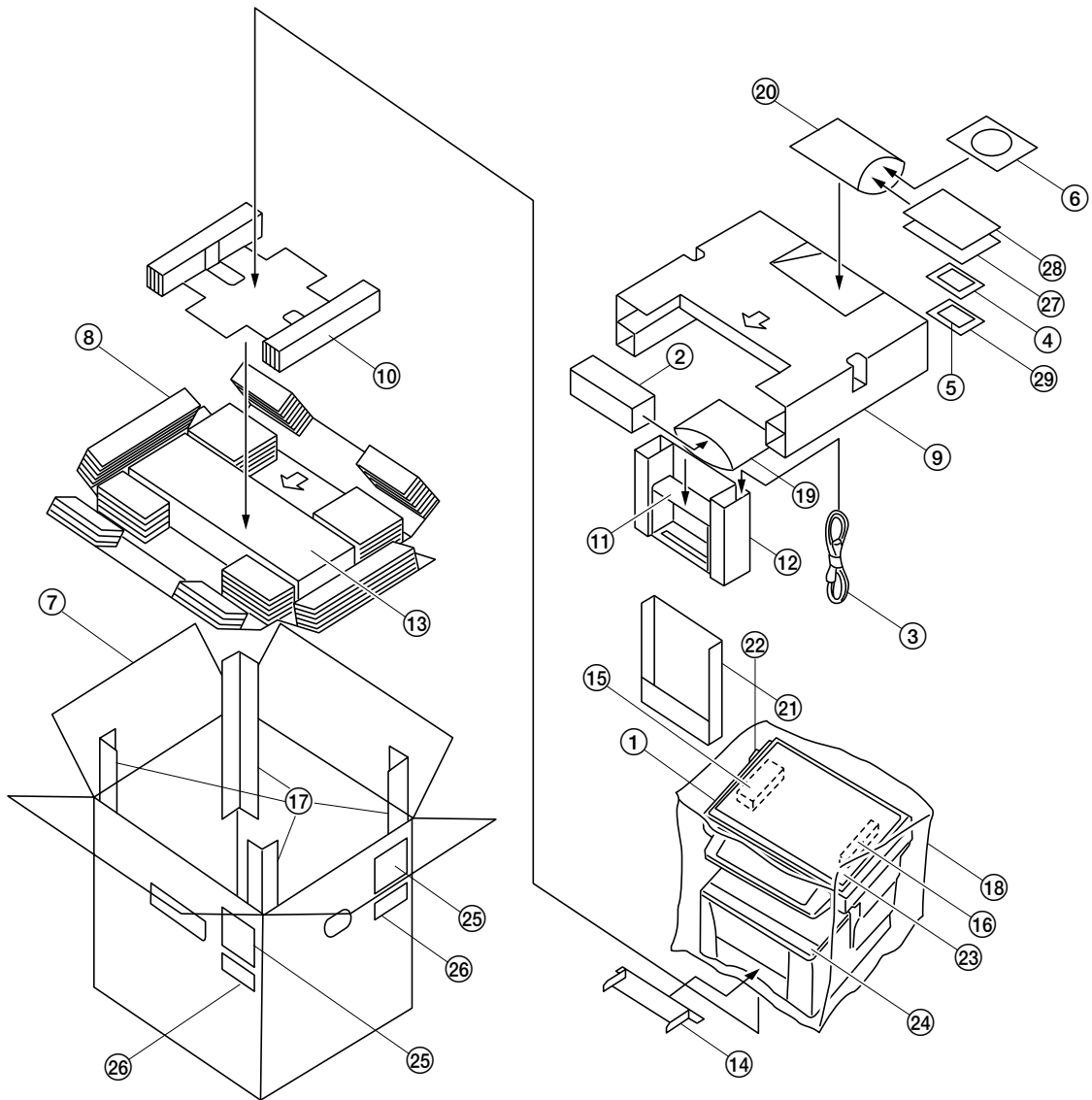
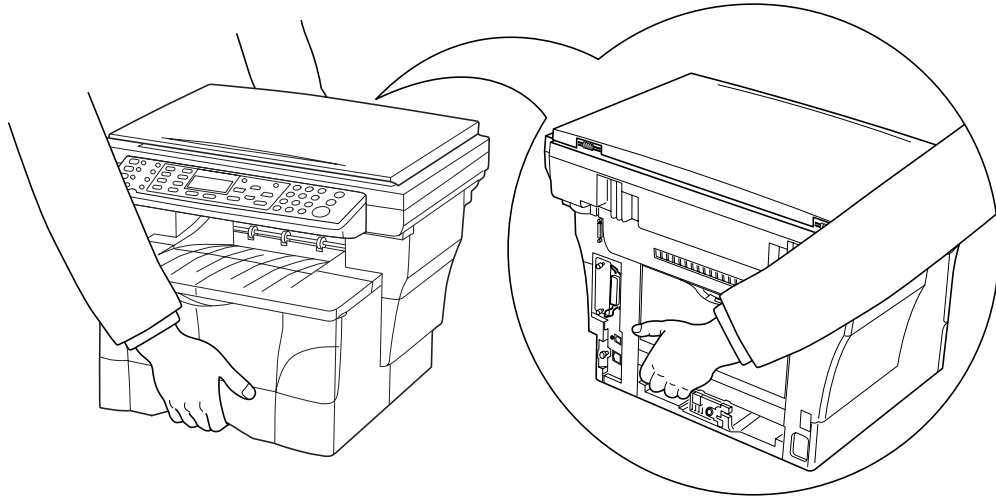

Figure 1-3-1 Unpacking

- | | | |
|-----------------------|-------------------|----------------------|
| ① Main body | ⑪ Front spacer | ⑳ Plastic bag |
| ② Toner container | ⑫ Front pad | ㉑ Pocket spacer |
| ③ Power cord | ⑬ Bottom spacer | ㉒ Paper tag |
| ④ Cleaning cloth | ⑭ Cassette spacer | ㉓ Top sheet |
| ⑤ One-touch key sheet | ⑮ Left pad | ㉔ Output tray sheet |
| ⑥ CD ROM | ⑯ Right pad | ㉕ Bar code labels |
| ⑦ Outer case | ⑰ Corner supports | ㉖ Label |
| ⑧ Bottom pad | ⑱ Products cover | ㉗ Operation guide |
| ⑨ Upper pad | ㉒ Plastic bag | ㉘ Installation guide |
| ⑩ Side pad | ㉓ Plastic bag | ㉙ Plastic bag |

CAUTIONS

- Be sure to hold both the front and rear sides of the machine when carrying it, as shown in the illustration.
- Be sure not to pull the cassette out when holding the front of the machine.
- Be sure that the original cover is closed whenever transporting the machine.
- Do not attempt to carry the machine by holding only the top portion. Doing so may result in you dropping the machine and thereby damaging the machine and/or its covers.

**Figure 1-3-2**

Remove the tapes, pads and sheets.

1. Remove the sheet and the two tapes.

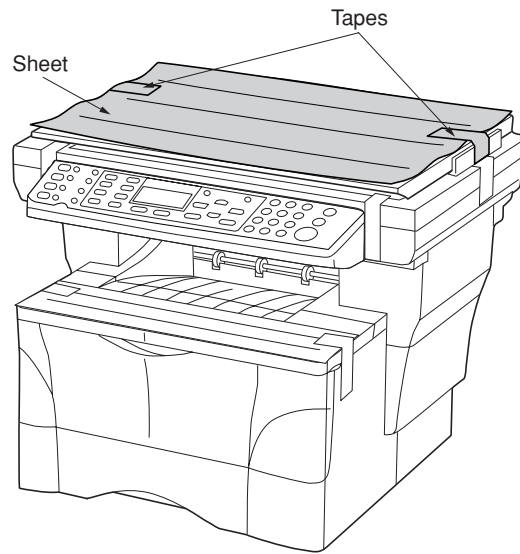

Figure 1-3-3

2. Open the original cover.

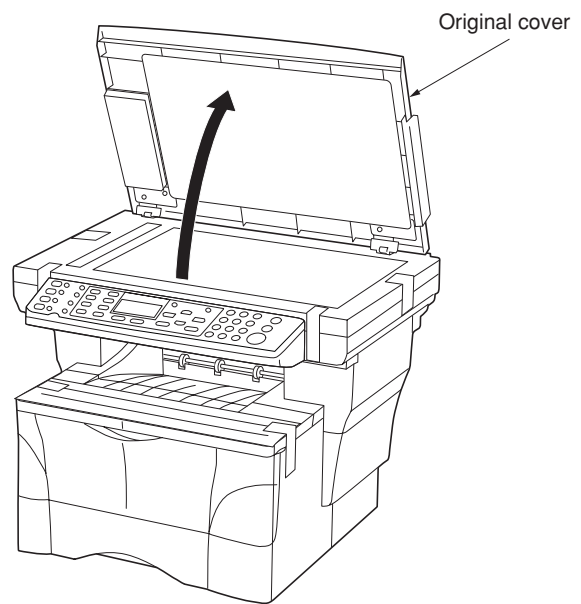

Figure 1-3-4

3. Remove the eight tapes, the two pads and the sheet.

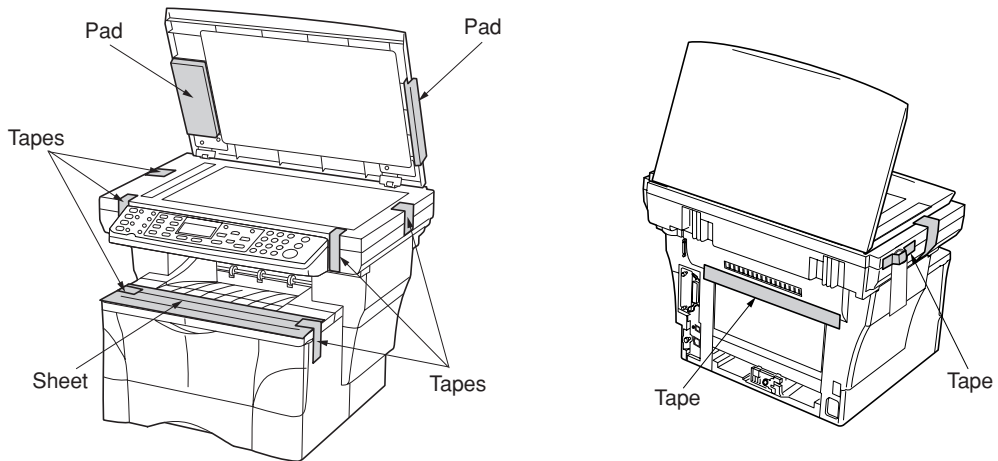

Figure 1-3-5

4. Pull the cassette out of the machine.

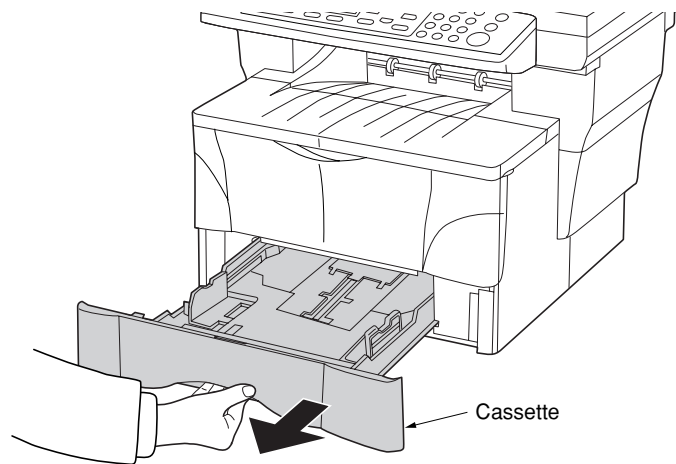

Figure 1-3-6

5. Remove the pad from inside the cassette.

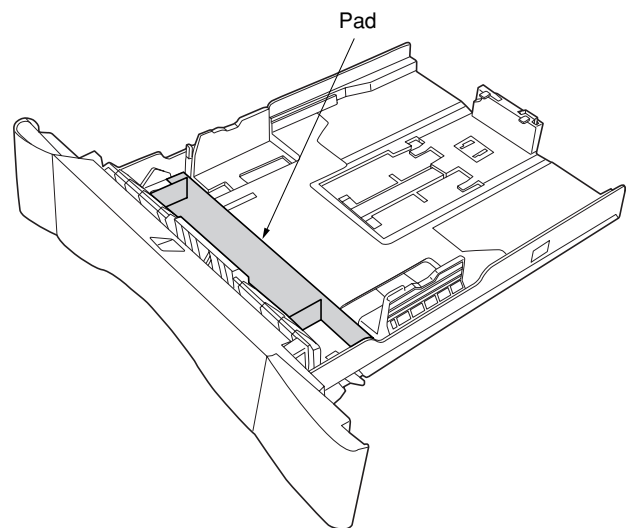

Figure 1-3-7

Remove the pin holding scanner unit.

1. Remove the yellow pin for scanner unit and the paper tag from the left side of the machine.

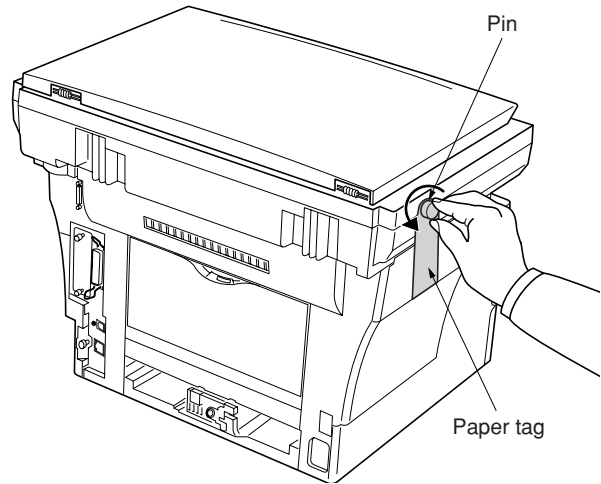

Figure 1-3-8

Install a toner container.

1. Open the front top cover and front cover.

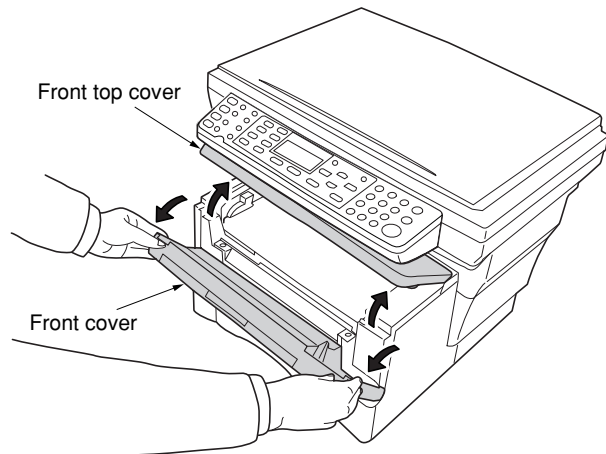

Figure 1-3-9

2. Store the pin for scanner unit on the inside of the front cover as shown in the illustration.

* Be sure to save this pin as it is essential that it be used whenever the machine is moved. The location for storing the pin is clearly marked on the right side of the inside portion of the front cover.

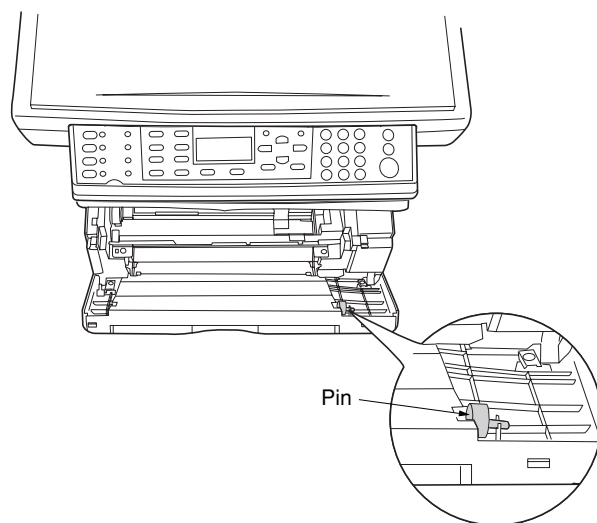

Figure 1-3-10

3. Remove the process unit from the machine.

CAUTIONS

- Place the process unit on a clean, level surface.
- Never expose the process unit to any sort of impact or shock.
- The drum in the process unit is sensitive to light. Never expose the drum even to normal office lighting (500 lux) for more than five minutes.

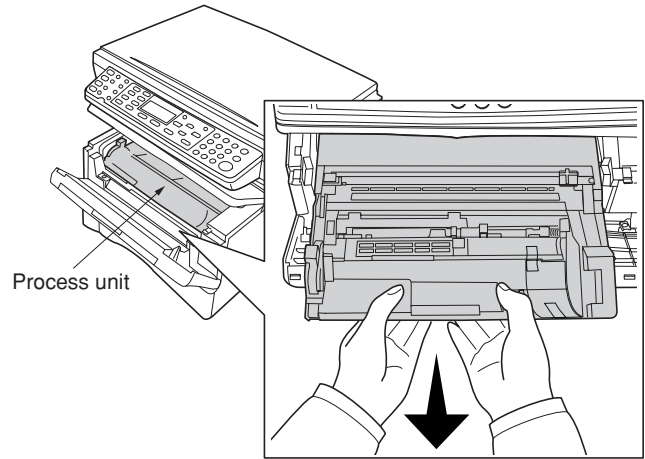

Figure 1-3-11

4. Remove the protective cardboard.

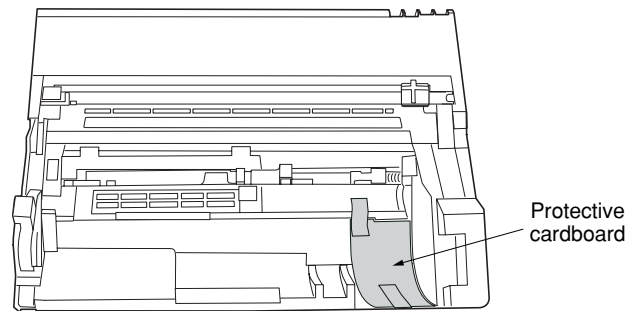

Figure 1-3-12

5. Move the lock lever until it is in its unlocked position (marked "UNLOCK").

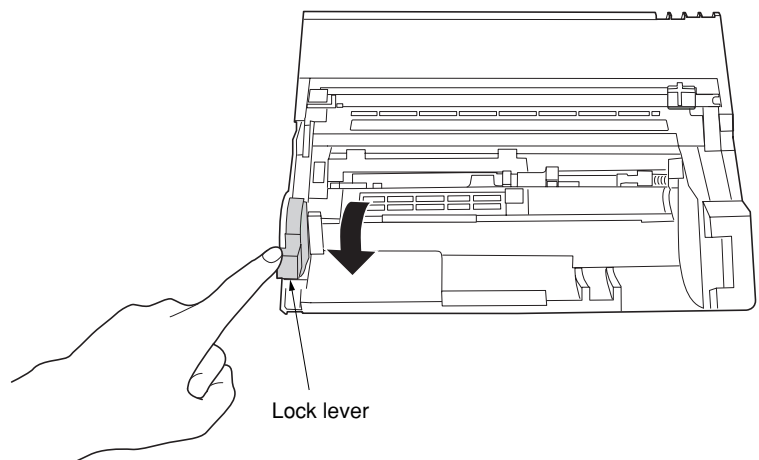

Figure 1-3-13

6. Shake the toner container horizontally back and forth five or six times so that the toner inside of it becomes evenly distributed.

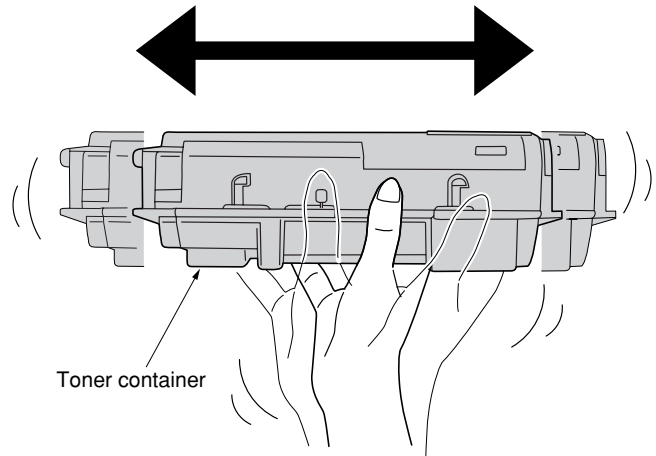

Figure 1-3-14

7. Remove the orange protective seal.

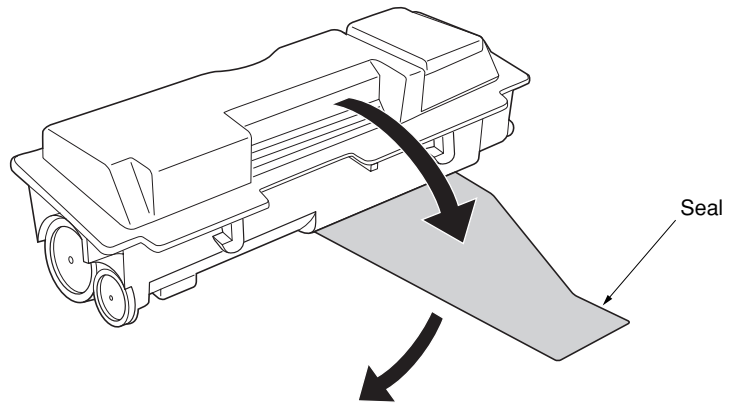

Figure 1-3-15

8. Align the knob on the left side of the container with the groove in the process unit and set the toner container into the process unit.

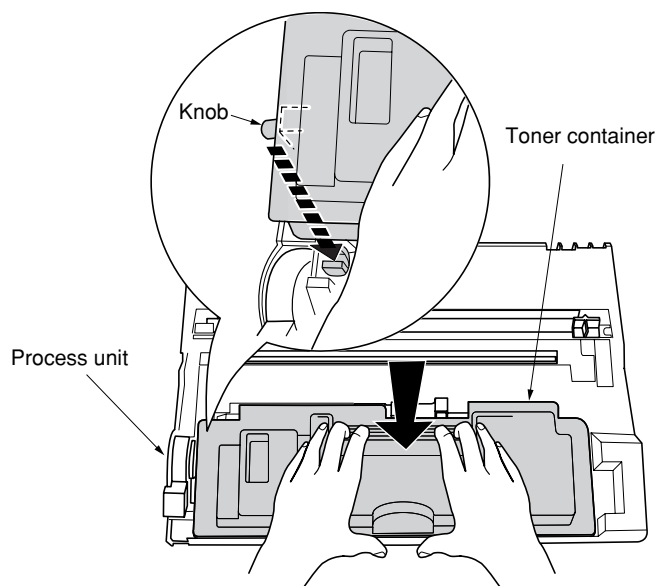

Figure 1-3-16

9. Hold the process unit stable and push on the areas marked "PUSH HERE" on the toner container until the container clicks into place.

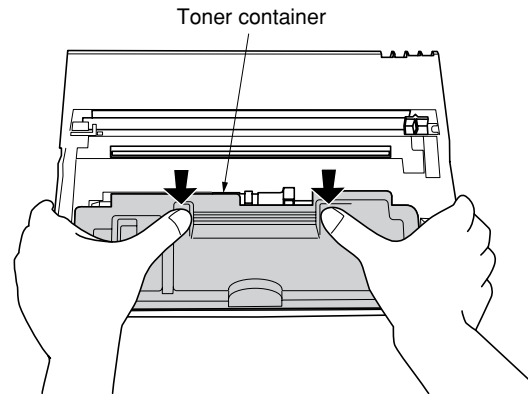

Figure 1-3-17

10. Push the lock lever back into its locked position.

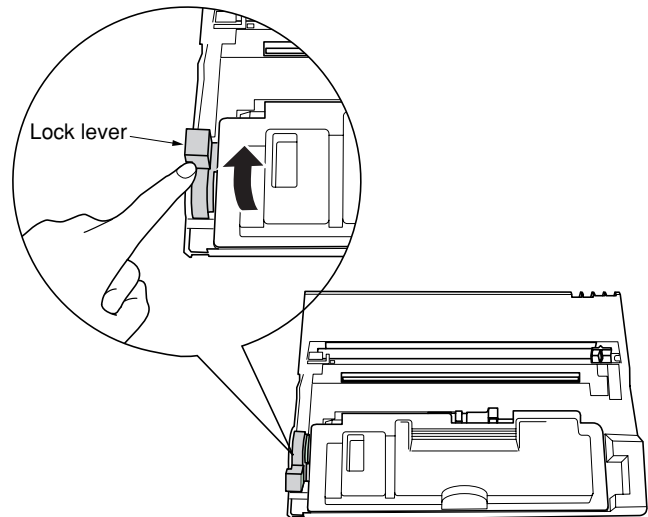

Figure 1-3-18

11. Set the process unit into the machine by aligning the pins on both sides of the process unit with the guides inside the machine, and then slide the process unit all the way back into the machine until it stops.

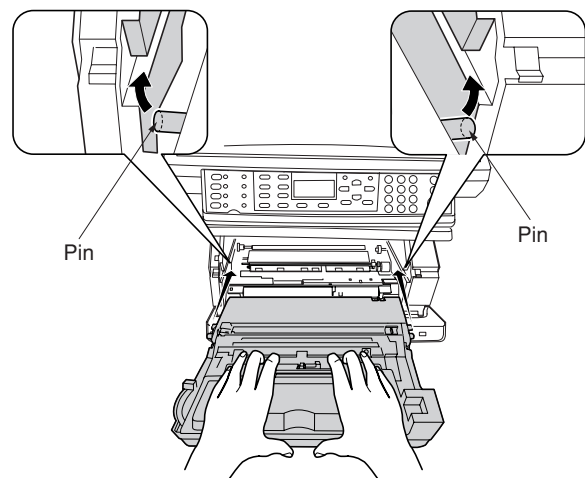

Figure 1-3-19

12. Close the front cover.

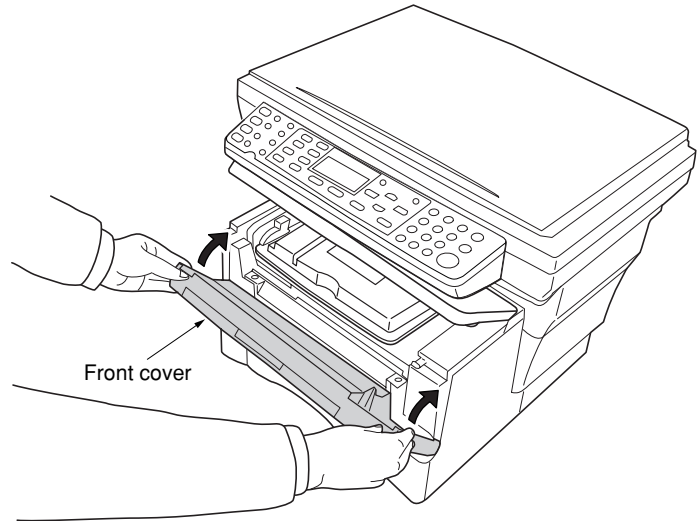

Figure 1-3-20

13. Close the front top cover.

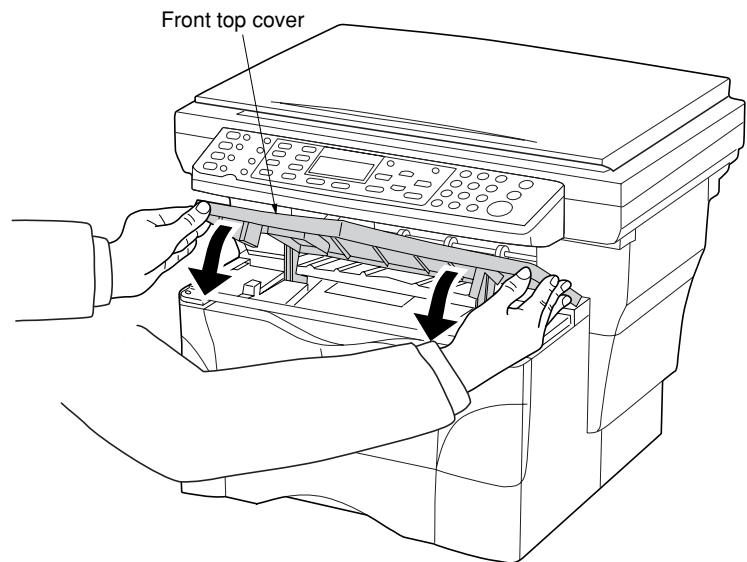

Figure 1-3-21

Connect the power cord.

- 1. Connect the power cord.

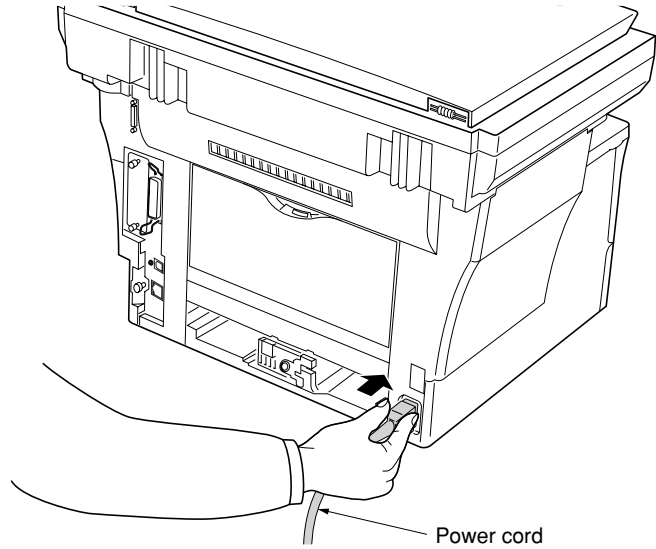

Figure 1-3-22

Initializing the machine.

- 1. Turn the power switch to the machine ON (|).

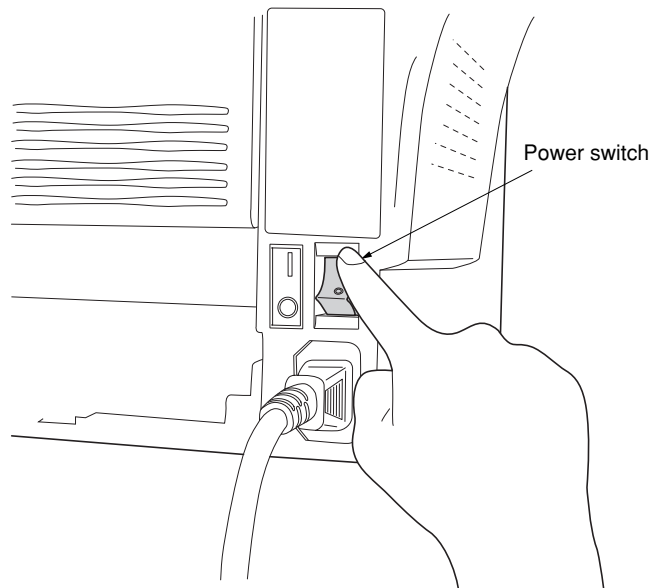

Figure 1-3-23

The machine will begin replenishing the toner. Wait until it has completed that operation. (15 minutes)
 Once the toner has been replenished and the machine is once again in a ready-to-use state, "Ready to copy" or "Ready to send" will appear on the message display and the Start indicator will light green.

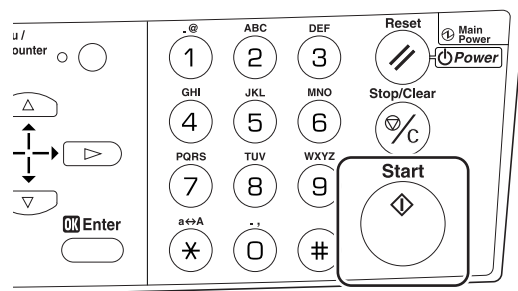
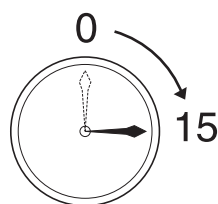

Figure 1-3-24

Load paper.

1. Pull the cassette out of the machine.

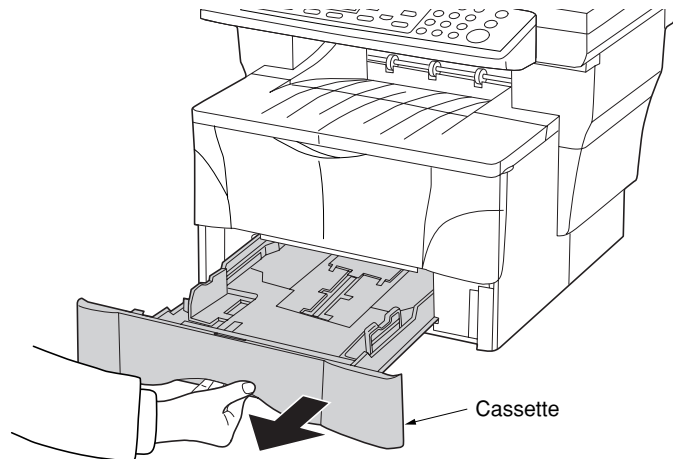

Figure 1-3-25

2. Adjust the paper stopper in the rear portion of the cassette to fit the size of the paper being loaded there by pressing in on the release buttons and sliding the paper stopper to the corresponding paper size.

NOTES

- The paper sizes are marked on the bottom of the cassette.
- The default factory setting is for A4/Letter size paper.

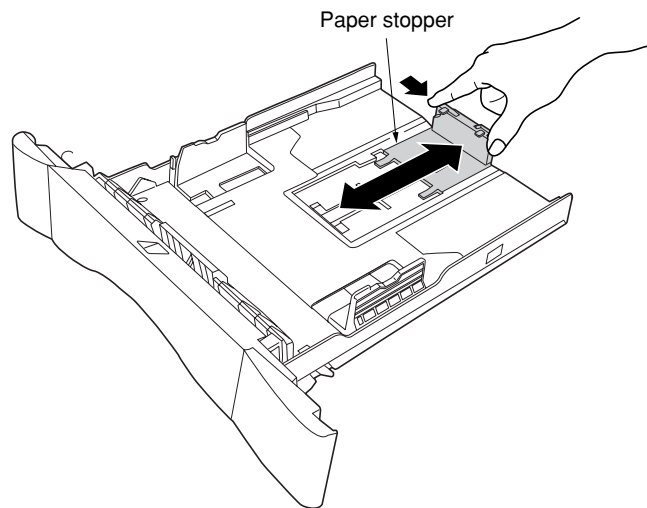

Figure 1-3-26

Adjusting the paper stopper for Folio or Oficio II size paper

- 1) Remove the stopper extension lock from the paper stopper.
- 2) Slide the paper stopper towards the rear of the cassette until the grooves that are cut into the paper stopper are aligned with the rear edge of the cassette.
- 3) Insert the stopper extension lock into the holes in the paper stopper, as shown in the illustration.

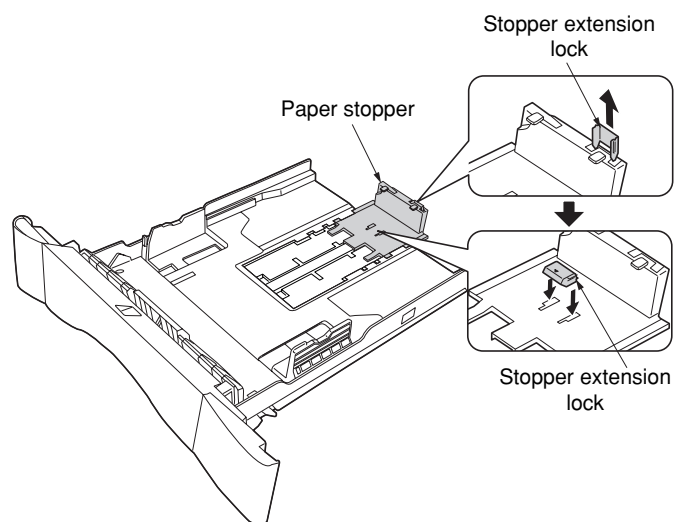

Figure 1-3-27

- 4) Press down on the stopper extension lock and slide the paper stopper towards the rear of the cassette to set the lock into place. The paper stopper is in position for Folio and Oficio II size paper.

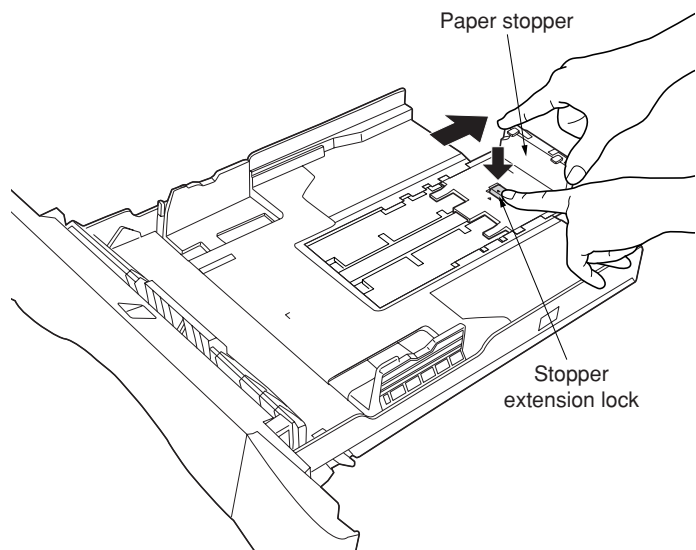

Figure 1-3-28

3. Adjust the paper width guides by pressing in on the release buttons and sliding the guides to fit the width of the paper being loaded in the cassette.

NOTES

- The paper sizes are marked on the bottom of the cassette.
- The default setting is for A4/Letter size paper.

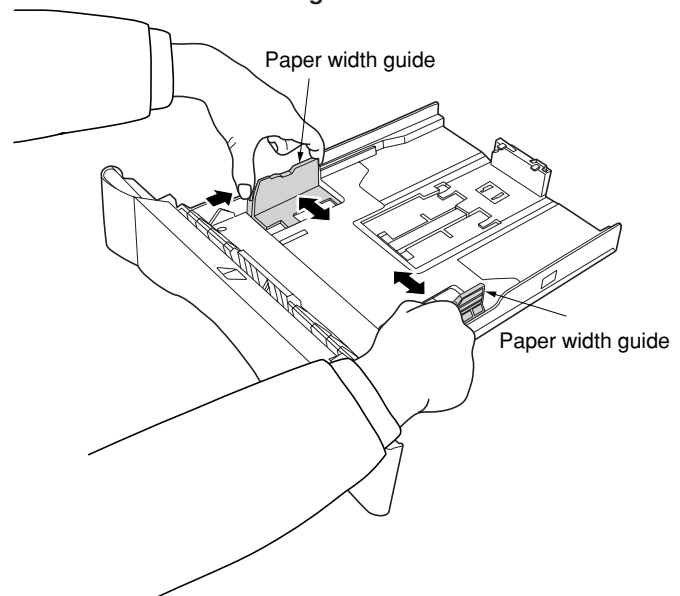

Figure 1-3-29

4. Set the paper in the cassette so that the leading edge is aligned against the paper stopper, but making sure that none of the paper gets caught on the overhanging tabs.

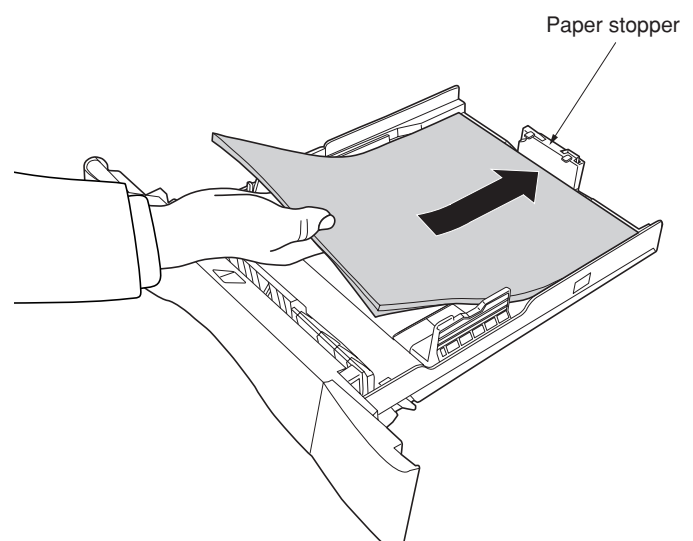

Figure 1-3-30

NOTES

- Always adjust the paper stopper and paper width guides before loading paper into the cassette. Failure to do so may result in skewed paper feed and/or a paper jam.
- Make sure that the paper is set securely against the paper stopper and the paper width guides. If there is any gap between the paper and the stopper or guides, readjust the paper stopper and/or the paper width guides, as appropriate.
- When you are loading paper into the cassette, make sure that the side to be copied or printed onto is facing downward.
- Be sure to load paper so that it is not folded or curled, etc.
- Do not load more paper than indicated by the lines located on the width guides.

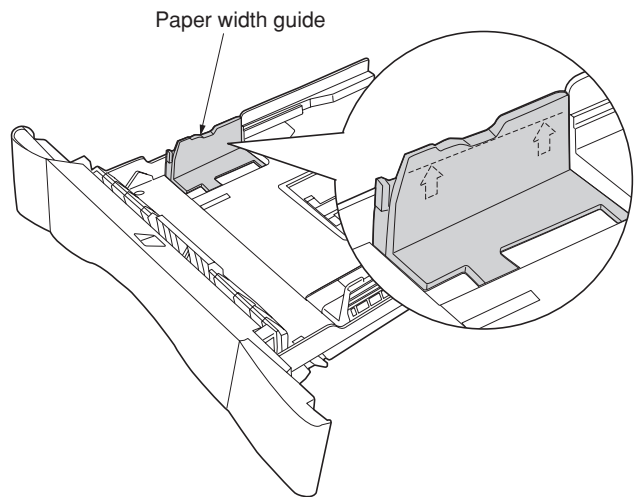

Figure 1-3-31

5. Push the cassette securely all the way back into the machine until it stops.

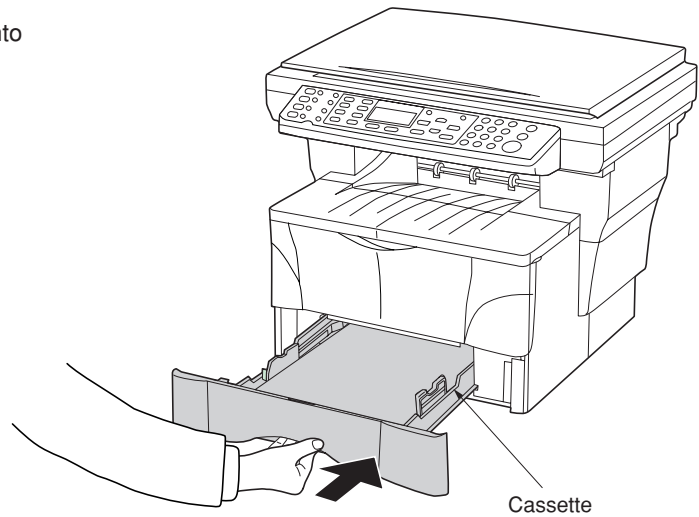
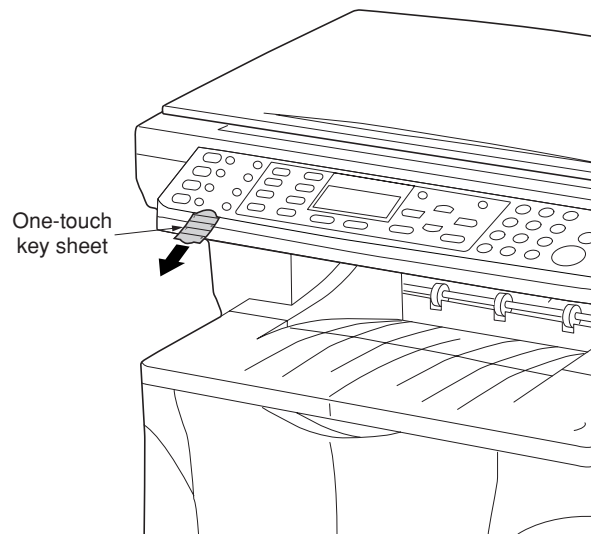

Figure 1-3-32

Using the one-touch key sheet.

1. Remove the one-touch key sheet from bottom side of the operation panel.

**Figure 1-3-33**

2. Enter the information for the registered destinations onto the one-touch key sheet. (There are 4 spare one-touch key sheets included with this machine.)
3. Insert the sheet back between the one-touch keys from the bottom side of the operation panel.

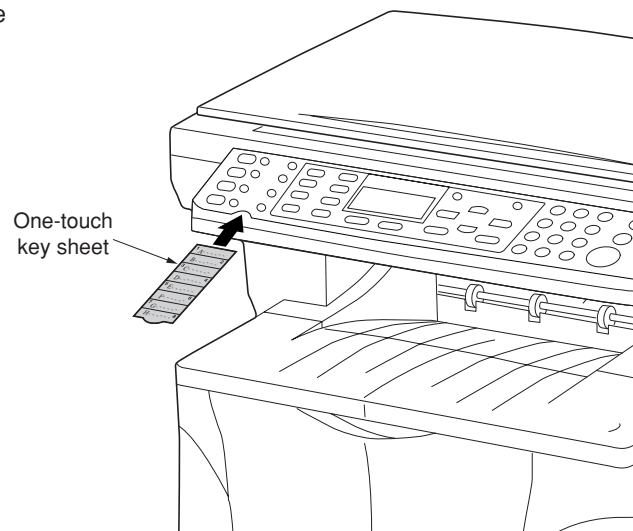
**Figure 1-3-34****Make test copies.****End of installation.**

1-3-2 Connecting the cables

(1) Connecting the network cable

To connect the machine to a network, use a network cable (10Base-T or 100Base-TX).

Procedure

1. Turn the power switch located on the rear side of the machine off (O), and remove the power cord from the outlet.

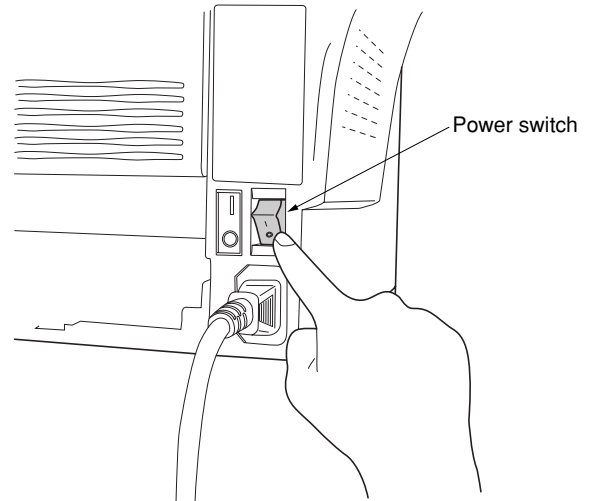

Figure 1-3-35

2. Connect the network cable to the network connector at the rear side of the machine.
3. Connect the other end of the network cable to network device (hub).
4. Make network settings.

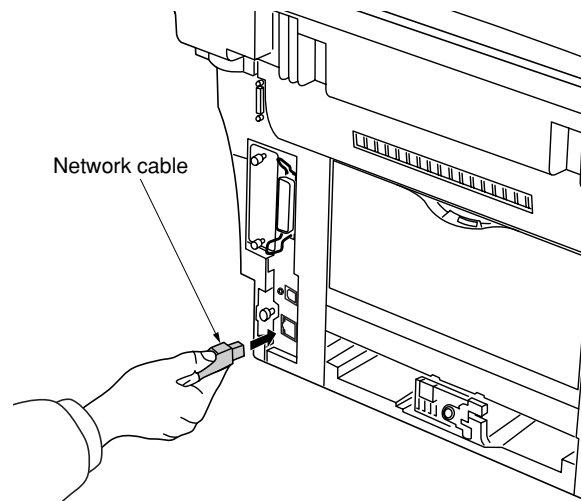

Figure 1-3-36

(2) Connecting the printer cable

To connect the machine directly to your computer, use either a parallel cable or USB cable.

Procedure

1. Turn the power switch located on the rear side of the machine off (O), remove the power cord from the outlet and turn the power off to computer.

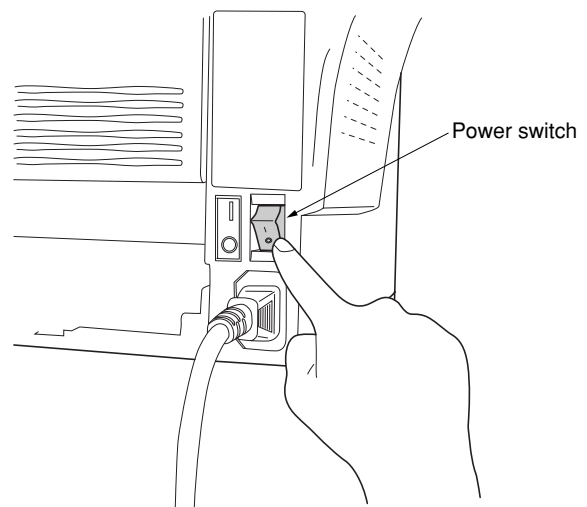
**Figure 1-3-37**

2. Connect the printer cable to the parallel interface connector or USB interface connector located at the rear side of the machine.
3. Connect the other end of the printer cable to the parallel interface connector or USB interface connector on computer.

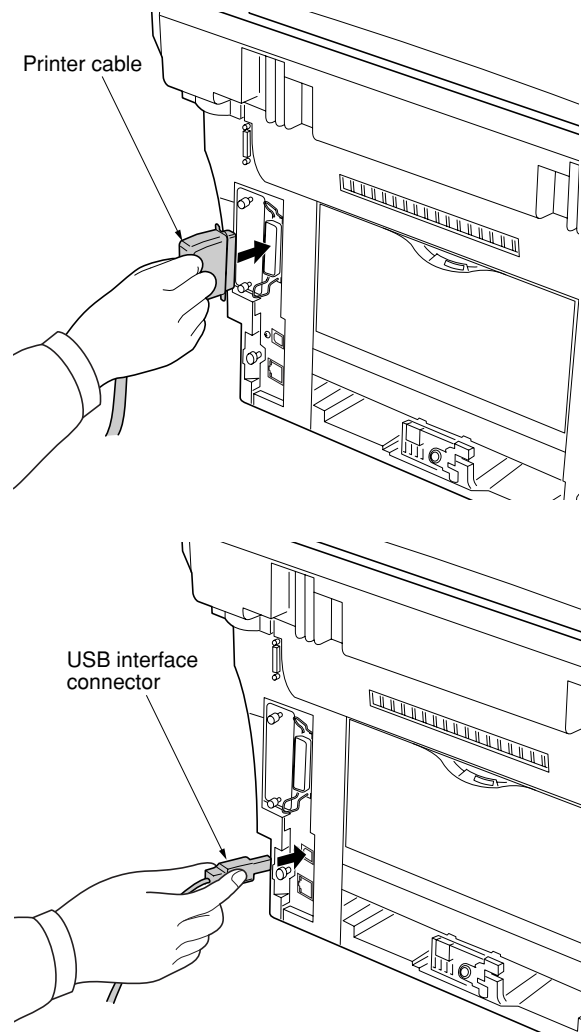
**Figure 1-3-38**

1-3-3 Installing the document processor (option)

Procedure

1. Remove all of the components to the document processor from the box.

CAUTION

Be sure to hold both sides of the document processor when carrying it, as shown in the illustration.

Be particularly careful NOT to touch the guide film or the thin white surface indicated by the (A) in the illustration.

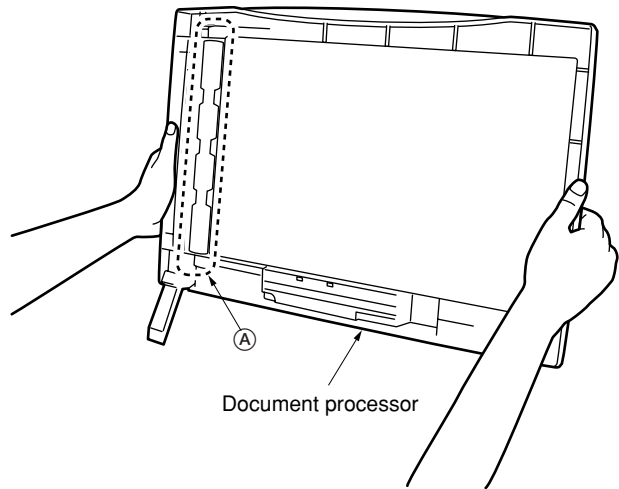

Figure 1-3-39

2. Turn the power switch to the copier OFF (O).

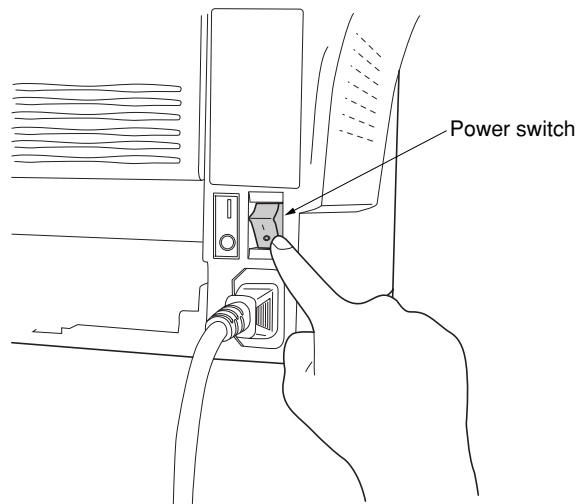

Figure 1-3-40

3. Open the original cover and lift it upward to remove it from the copier.

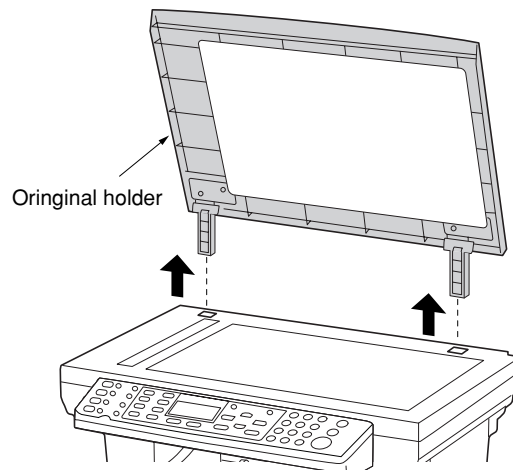
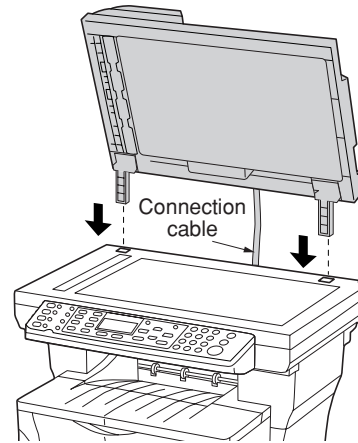

Figure 1-3-41

- Attach the document processor to the copier.

CAUTION

Be sure that the connection cable does not get caught between the document processor and the copier when attaching the document processor to the copier.

**Figure 1-3-42**

- Gently close the document processor.

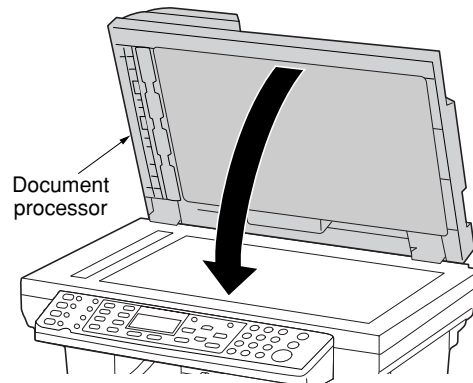
**Figure 1-3-43**

- Attached the open end of the connection cable to the connector on the copier.

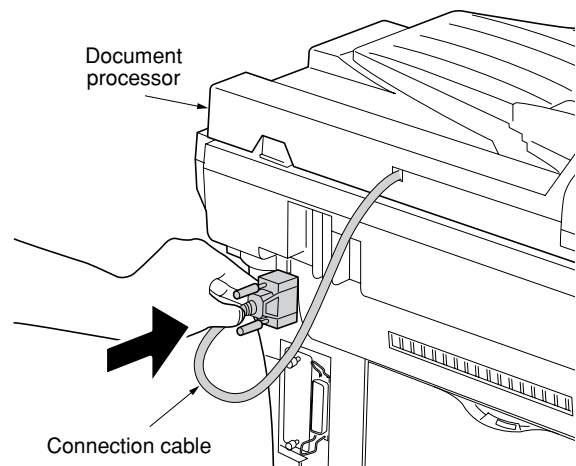
**Figure 1-3-44**

CAUTION

Be sure to tighten the pins securely when connecting the cable.

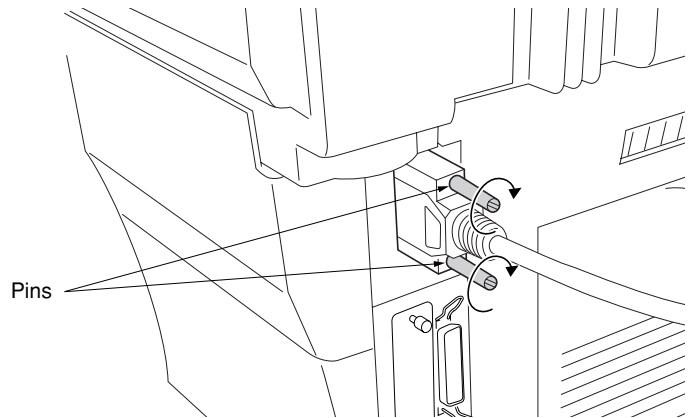

Figure 1-3-45

7. Turn the power switch to the copier back ON (|). Warm up will begin. "1" will appear on the operation panel and the Start indicator will light when the copier is in a copy-ready state.

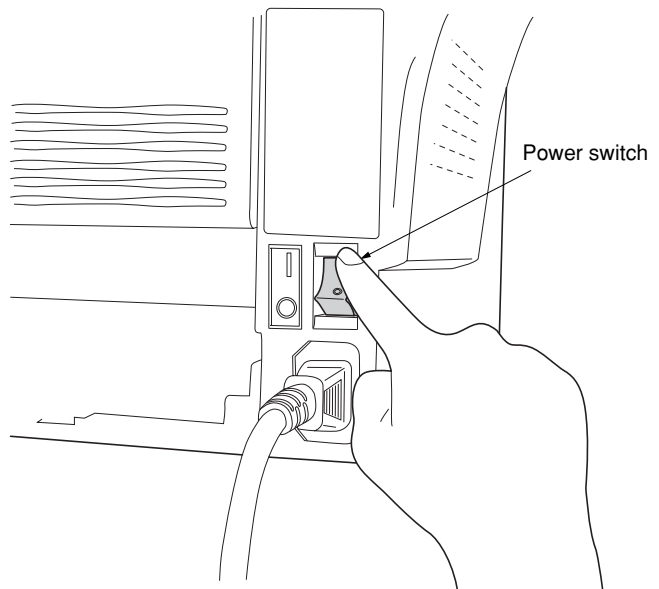

Figure 1-3-46

1-3-4 Installing the expanding memory (option)

The main board of the machine is equipped with one socket for memory expansion. Expansion memory is available in the form of DIMM (Dual In-line Memory Module).

CAUTION

Take precautions that no foreign substances such as metal chips or liquid get inside the machine during the installation process. Operation of the machine during the presence of a foreign substance may lead to fire or electric shock.

WARNING

Turn the machine's power switch off. Unplug the machine's power cable.

Procedure

1. Remove the one screw and then remove the memory cover.
3. Open the clips on both ends of the DIMM socket.
4. Insert the DIMM into the DIMM socket so that the notches on the DIMM align with the corresponding protrusions in the slot.
5. Close the clips on the DIMM slot to secure the DIMM.

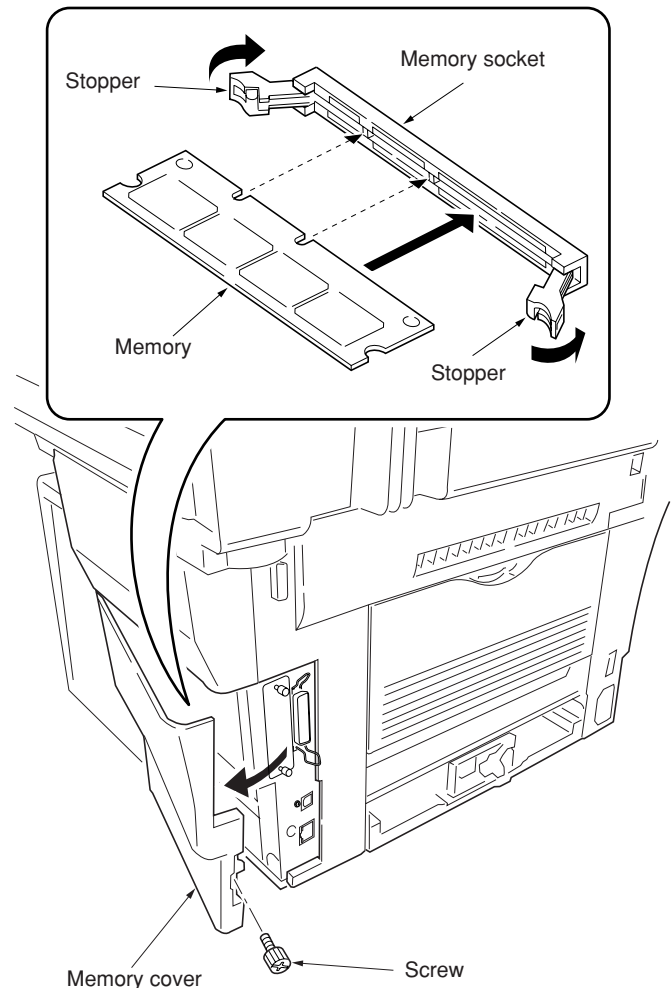

Figure 1-3-47 Inserting the DIMM

1-4-1 Maintenance mode

The machine is equipped with a maintenance function which can be used to maintain and service the machine.

(1) Executing a maintenance item



* The test print mode cannot be stopped until the preset number of sheets is printed. To stop the operation, remove the cassette to cause a paper empty state. To terminate the test print mode in the middle of operation, you must turn off the power switch and then on again to exit the maintenance mode.

(2) Maintenance modes

Category	Item No.	Maintenance	Initial setting*
General	U000	Outputting an own-status report	—
Initialization	U020	Initializing all data	—
Drive, paper feed and paper conveying system	U034	Setting paper timing • Adjusting the leading edge registration • Adjusting the center line	— —
	U051	Adjusting the amount of slack in the paper	0
Optical	U060	Adjusting the scanner input properties	12
	U063	Adjusting the shading position	0
	U065	Adjusting the scanner magnification • Main scanning direction • auxiliary scanning direction	0 0
	U066	Adjusting the leading edge registration for scanning an original on the contact glass	6
	U067	Adjusting the center line for scanning an original on the contact glass	7
	U070	Adjusting the DP magnification	−8
	U071	Adjusting the DP scanning timing • Adjusting leading edge registration • Adjusting trailing edge registration	12 0
	U072	Adjusting the DP center line	2.7
	U074	Adjusting the DP input light luminosity	1
	U087	Turning the DP scanning position adjust mode on/off	35
	U089	Outputting a MIP-PG pattern	—
High voltage	U101	Setting the other high voltages	26/55/48/ 42/24/60
Developing	U130	Initial setting for the developer	OFF
	U144	Setting toner loading operation	1
	U157	Checking/clearing the developing drive time	—
Fixing and cleaning	U161	Setting the fixing control temperature • Primary stabilization fixing temperature • Secondary stabilization fixing temperature • Copying operation temperature 1 • Copying operation temperature 2 • Number of sheets for fixing control	135 160 190 195 5
	U163	Resetting the fixing problem data	—
Operation panel and support equipment	U203	Operating DP separately	—
	U207	Checking the operation panel keys	—
Mode setting	U260	Changing the copy count timing	—
Image processing	U403	Adjusting margins for scanning an original on the contact glass	—
	U404	Adjusting margins for scanning an original from the DP	—
	U411	Adjusting the scanner automatically	—
	U425	Setting the target	—
Others	U901	Checking/clearing print counts by paper feed locations	—
	U905	Checking counts by the DP	—
	U911	Checking/clearing print counts by paper size	—
	U927	Clearing accounting counter	—
	U928	Checking/clearing the machine life count	—

* Initial setting for executing maintenance item U020

(3) Contents of maintenance mode items

Maintenance item No.	Description																																																																														
U000	<p>Outputting an own-status report</p> <p>Description Outputs lists of the current settings of the maintenance items, and paper jam and service call occurrences and event log report.</p> <p>Purpose To check the current setting of the maintenance items, or paper jam or service call occurrences. Before initializing the backup RAM, output a list of the current settings of the maintenance items to reenter the settings after initialization or replacement.</p> <p>Method</p> <ol style="list-style-type: none"> 1. Press the enter key. A selection item appears. 2. Select the item to be output using the up/down cursor keys. <table border="1" style="width: 100%; border-collapse: collapse;"> <thead> <tr> <th style="text-align: left;">Display</th> <th style="text-align: left;">Output list</th> </tr> </thead> <tbody> <tr> <td>Maintenance</td> <td>Outputs the maintenance list</td> </tr> <tr> <td>Event Log</td> <td>Outputs the event log report</td> </tr> </tbody> </table> <ol style="list-style-type: none"> 3. Press the enter key. The test print mode is entered and a list is output. <p>Completion Press the back key while a selection item is displayed. The indication for selecting a maintenance item No. appears.</p> <p>Detail of event log</p> <div style="border: 1px solid black; padding: 10px; margin: 10px 0;"> <h2 style="text-align: center;">Event Log</h2> <h3 style="text-align: center;">MFP</h3> <p style="text-align: center;">Firmware Version 2DD_2000.001.008 2004.03.01</p> <hr style="border: 2px solid gray;"/> <div style="display: flex; justify-content: space-between;"> <div style="width: 45%;"> <p>① Paper Jam Log</p> <table border="1" style="width: 100%; border-collapse: collapse;"> <thead> <tr> <th>#</th> <th>Count.</th> <th>Event Descriptions</th> </tr> </thead> <tbody> <tr> <td>1</td> <td>0</td> <td>05.43.01.08.01.01 Paper Jam/Printre Main Unit/Paper Late</td> </tr> </tbody> </table> <div style="text-align: center; margin-top: 10px;"> <table border="1" style="margin: 0 auto; border-collapse: collapse;"> <tr> <td>(a)</td> <td>(b)</td> <td>(c)</td> <td>(d)</td> <td>(e)</td> <td>(f)</td> </tr> <tr> <td colspan="6" style="text-align: center;">05.43.01.08.01.01</td> </tr> </table> </div> </div> <div style="width: 45%;"> <p>② Service Call Log</p> <table border="1" style="width: 100%; border-collapse: collapse;"> <thead> <tr> <th>#</th> <th>Count.</th> <th>Service Code</th> </tr> </thead> <tbody> <tr><td>8</td><td>9999999</td><td>01.80</td></tr> <tr><td>7</td><td>9999998</td><td>F4.50</td></tr> <tr><td>6</td><td>9999997</td><td>01.80</td></tr> <tr><td>5</td><td>9999996</td><td>F4.15</td></tr> <tr><td>4</td><td>9999995</td><td>01.80</td></tr> <tr><td>3</td><td>9999994</td><td>01.80</td></tr> <tr><td>2</td><td>9999993</td><td>01.80</td></tr> <tr><td>1</td><td>9999992</td><td>01.80</td></tr> </tbody> </table> <p>③ Maintenance Log</p> <table border="1" style="width: 100%; border-collapse: collapse;"> <thead> <tr> <th>#</th> <th>Count.</th> <th>Item</th> </tr> </thead> <tbody> <tr> <td>1</td> <td>9999999</td> <td>01.00</td> </tr> </tbody> </table> </div> </div> <p>④ Counter Log</p> <table border="1" style="width: 100%; border-collapse: collapse;"> <tbody> <tr> <td>J03:000</td> <td>J10:000</td> <td>J20:000</td> <td>J40:000</td> <td>J71:000</td> <td>J7F:000</td> <td>CF450:001</td> </tr> <tr> <td>J04:000</td> <td>J11:000</td> <td>J21:000</td> <td>J50:000</td> <td>J7A:000</td> <td>C0180:006</td> <td>T00:001</td> </tr> <tr> <td>J05:001</td> <td>J12:000</td> <td>J22:000</td> <td>J70:000</td> <td>J7B:000</td> <td>CF415:001</td> <td></td> </tr> </tbody> </table> </div>	Display	Output list	Maintenance	Outputs the maintenance list	Event Log	Outputs the event log report	#	Count.	Event Descriptions	1	0	05.43.01.08.01.01 Paper Jam/Printre Main Unit/Paper Late	(a)	(b)	(c)	(d)	(e)	(f)	05.43.01.08.01.01						#	Count.	Service Code	8	9999999	01.80	7	9999998	F4.50	6	9999997	01.80	5	9999996	F4.15	4	9999995	01.80	3	9999994	01.80	2	9999993	01.80	1	9999992	01.80	#	Count.	Item	1	9999999	01.00	J03:000	J10:000	J20:000	J40:000	J71:000	J7F:000	CF450:001	J04:000	J11:000	J21:000	J50:000	J7A:000	C0180:006	T00:001	J05:001	J12:000	J22:000	J70:000	J7B:000	CF415:001	
Display	Output list																																																																														
Maintenance	Outputs the maintenance list																																																																														
Event Log	Outputs the event log report																																																																														
#	Count.	Event Descriptions																																																																													
1	0	05.43.01.08.01.01 Paper Jam/Printre Main Unit/Paper Late																																																																													
(a)	(b)	(c)	(d)	(e)	(f)																																																																										
05.43.01.08.01.01																																																																															
#	Count.	Service Code																																																																													
8	9999999	01.80																																																																													
7	9999998	F4.50																																																																													
6	9999997	01.80																																																																													
5	9999996	F4.15																																																																													
4	9999995	01.80																																																																													
3	9999994	01.80																																																																													
2	9999993	01.80																																																																													
1	9999992	01.80																																																																													
#	Count.	Item																																																																													
1	9999999	01.00																																																																													
J03:000	J10:000	J20:000	J40:000	J71:000	J7F:000	CF450:001																																																																									
J04:000	J11:000	J21:000	J50:000	J7A:000	C0180:006	T00:001																																																																									
J05:001	J12:000	J22:000	J70:000	J7B:000	CF415:001																																																																										

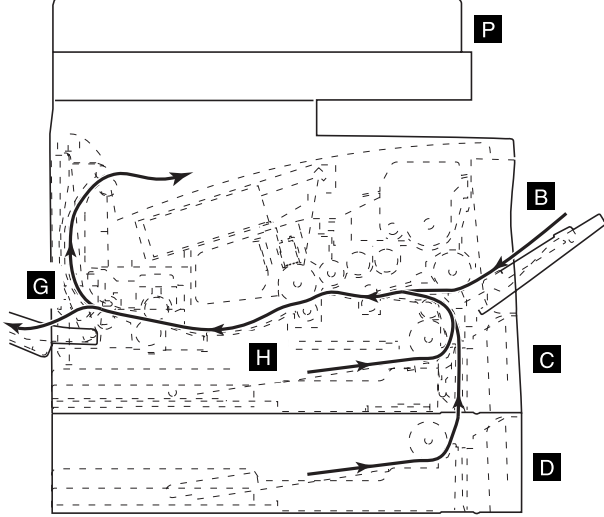
Maintenance item No.	Description
<p>① Paper Jam Log</p>	<p>Description</p> <p>#: Log number 1 to 16 jams are recorded. (If the number of jams exceeds 16, the oldest log is deleted.) Count.: Number of pages Total page counter at the time of jam Event: Log code Six types of two-digit hexadecimal numbers are displayed. Cause of jam/jam position/paper feed location/paper size/media type /ejection location Descriptions: Indicates the description of error</p> <p>(a) Cause of jam 03: No paper feed [-] 04: Cover open JAM [-] 05: Secondary paper feed timeout [H] 10: No paper feed from the MP tray [B] 11: No paper feed from the drawer [C] 12: No paper feed from the optional drawer [D] 20: Multiple sheets in the MP tray [B] 21: Multiple sheets in the drawer [C] 22: Multiple sheets in the optional drawer [D] 40: Misfeed in the fixing section [H] 50: Misfeed in the exit section [G] 70: No original feed [P] 71: An original jam in the original conveying section [P] 7A: DP original cover or front top cover open JAM [P] 7B: DP open JAM [P] 7F: Original remaining JAM [P]</p> <p>(b) Jam position</p>  <p>42 [B]: MP tray 43 [C]: Drawer 44 [D]: Optional drawer 47 [G]: Face-up/down eject tray 48 [H]: MFP 50 [P]: DP</p> <p>(c) Paper feed location 00: MP tray 01: Drawer 02: Optional drawer</p>

Maintenance item No.	Description																																																								
	<table border="1"> <thead> <tr> <th data-bbox="571 275 890 315">Item</th> <th data-bbox="890 275 1447 315">Description</th> </tr> </thead> <tbody> <tr> <td data-bbox="571 315 890 584">(c) Paper size</td> <td data-bbox="890 315 1447 584"> <table border="0"> <tr> <td>01: Envelope Monarch</td> <td>09: B5</td> <td>1F: Postcard</td> </tr> <tr> <td>02: Envelope #10</td> <td>0D: A5</td> <td>20: Reply-paid postcard</td> </tr> <tr> <td>03: Envelope DL</td> <td>0E: A6</td> <td>21: Officio II</td> </tr> <tr> <td>04: Envelope C5</td> <td>0F: B6</td> <td>28: 16K</td> </tr> <tr> <td>05: Executive</td> <td>10: Envelope #9</td> <td>32: Statement</td> </tr> <tr> <td>06: Letter</td> <td>11: Envelope #6</td> <td>33: Folio</td> </tr> <tr> <td>07: Legal</td> <td>12: ISO B5</td> <td>34: Western 2</td> </tr> <tr> <td>08: A4</td> <td>13: Custom</td> <td>35: Western 4</td> </tr> </table> </td> </tr> <tr> <td data-bbox="571 584 890 853">(d) Media type</td> <td data-bbox="890 584 1447 853"> <table border="0"> <tr> <td>01: Plain</td> <td>09: Letterhead</td> <td>17: Custom 3</td> </tr> <tr> <td>02: Transparency</td> <td>0A: Color</td> <td>18: Custom 4</td> </tr> <tr> <td>03: Preprinted</td> <td>0B: Prepunched</td> <td>19: Custom 5</td> </tr> <tr> <td>04: Label</td> <td>0C: Envelope</td> <td>1A: Custom 6</td> </tr> <tr> <td>05: Bond</td> <td>0D: Cardstock</td> <td>1B: Custom 7</td> </tr> <tr> <td>06: Recycled</td> <td>10: Thick</td> <td>1C: Custom 8</td> </tr> <tr> <td>07: Vellum</td> <td>15: Custom 1</td> <td></td> </tr> <tr> <td>08: Rough</td> <td>16: Custom 2</td> <td></td> </tr> </table> </td> </tr> <tr> <td data-bbox="571 853 890 920">(e) Ejection location</td> <td data-bbox="890 853 1447 920">01: Face-down output tray</td> </tr> </tbody> </table>	Item	Description	(c) Paper size	<table border="0"> <tr> <td>01: Envelope Monarch</td> <td>09: B5</td> <td>1F: Postcard</td> </tr> <tr> <td>02: Envelope #10</td> <td>0D: A5</td> <td>20: Reply-paid postcard</td> </tr> <tr> <td>03: Envelope DL</td> <td>0E: A6</td> <td>21: Officio II</td> </tr> <tr> <td>04: Envelope C5</td> <td>0F: B6</td> <td>28: 16K</td> </tr> <tr> <td>05: Executive</td> <td>10: Envelope #9</td> <td>32: Statement</td> </tr> <tr> <td>06: Letter</td> <td>11: Envelope #6</td> <td>33: Folio</td> </tr> <tr> <td>07: Legal</td> <td>12: ISO B5</td> <td>34: Western 2</td> </tr> <tr> <td>08: A4</td> <td>13: Custom</td> <td>35: Western 4</td> </tr> </table>	01: Envelope Monarch	09: B5	1F: Postcard	02: Envelope #10	0D: A5	20: Reply-paid postcard	03: Envelope DL	0E: A6	21: Officio II	04: Envelope C5	0F: B6	28: 16K	05: Executive	10: Envelope #9	32: Statement	06: Letter	11: Envelope #6	33: Folio	07: Legal	12: ISO B5	34: Western 2	08: A4	13: Custom	35: Western 4	(d) Media type	<table border="0"> <tr> <td>01: Plain</td> <td>09: Letterhead</td> <td>17: Custom 3</td> </tr> <tr> <td>02: Transparency</td> <td>0A: Color</td> <td>18: Custom 4</td> </tr> <tr> <td>03: Preprinted</td> <td>0B: Prepunched</td> <td>19: Custom 5</td> </tr> <tr> <td>04: Label</td> <td>0C: Envelope</td> <td>1A: Custom 6</td> </tr> <tr> <td>05: Bond</td> <td>0D: Cardstock</td> <td>1B: Custom 7</td> </tr> <tr> <td>06: Recycled</td> <td>10: Thick</td> <td>1C: Custom 8</td> </tr> <tr> <td>07: Vellum</td> <td>15: Custom 1</td> <td></td> </tr> <tr> <td>08: Rough</td> <td>16: Custom 2</td> <td></td> </tr> </table>	01: Plain	09: Letterhead	17: Custom 3	02: Transparency	0A: Color	18: Custom 4	03: Preprinted	0B: Prepunched	19: Custom 5	04: Label	0C: Envelope	1A: Custom 6	05: Bond	0D: Cardstock	1B: Custom 7	06: Recycled	10: Thick	1C: Custom 8	07: Vellum	15: Custom 1		08: Rough	16: Custom 2		(e) Ejection location	01: Face-down output tray
Item	Description																																																								
(c) Paper size	<table border="0"> <tr> <td>01: Envelope Monarch</td> <td>09: B5</td> <td>1F: Postcard</td> </tr> <tr> <td>02: Envelope #10</td> <td>0D: A5</td> <td>20: Reply-paid postcard</td> </tr> <tr> <td>03: Envelope DL</td> <td>0E: A6</td> <td>21: Officio II</td> </tr> <tr> <td>04: Envelope C5</td> <td>0F: B6</td> <td>28: 16K</td> </tr> <tr> <td>05: Executive</td> <td>10: Envelope #9</td> <td>32: Statement</td> </tr> <tr> <td>06: Letter</td> <td>11: Envelope #6</td> <td>33: Folio</td> </tr> <tr> <td>07: Legal</td> <td>12: ISO B5</td> <td>34: Western 2</td> </tr> <tr> <td>08: A4</td> <td>13: Custom</td> <td>35: Western 4</td> </tr> </table>	01: Envelope Monarch	09: B5	1F: Postcard	02: Envelope #10	0D: A5	20: Reply-paid postcard	03: Envelope DL	0E: A6	21: Officio II	04: Envelope C5	0F: B6	28: 16K	05: Executive	10: Envelope #9	32: Statement	06: Letter	11: Envelope #6	33: Folio	07: Legal	12: ISO B5	34: Western 2	08: A4	13: Custom	35: Western 4																																
01: Envelope Monarch	09: B5	1F: Postcard																																																							
02: Envelope #10	0D: A5	20: Reply-paid postcard																																																							
03: Envelope DL	0E: A6	21: Officio II																																																							
04: Envelope C5	0F: B6	28: 16K																																																							
05: Executive	10: Envelope #9	32: Statement																																																							
06: Letter	11: Envelope #6	33: Folio																																																							
07: Legal	12: ISO B5	34: Western 2																																																							
08: A4	13: Custom	35: Western 4																																																							
(d) Media type	<table border="0"> <tr> <td>01: Plain</td> <td>09: Letterhead</td> <td>17: Custom 3</td> </tr> <tr> <td>02: Transparency</td> <td>0A: Color</td> <td>18: Custom 4</td> </tr> <tr> <td>03: Preprinted</td> <td>0B: Prepunched</td> <td>19: Custom 5</td> </tr> <tr> <td>04: Label</td> <td>0C: Envelope</td> <td>1A: Custom 6</td> </tr> <tr> <td>05: Bond</td> <td>0D: Cardstock</td> <td>1B: Custom 7</td> </tr> <tr> <td>06: Recycled</td> <td>10: Thick</td> <td>1C: Custom 8</td> </tr> <tr> <td>07: Vellum</td> <td>15: Custom 1</td> <td></td> </tr> <tr> <td>08: Rough</td> <td>16: Custom 2</td> <td></td> </tr> </table>	01: Plain	09: Letterhead	17: Custom 3	02: Transparency	0A: Color	18: Custom 4	03: Preprinted	0B: Prepunched	19: Custom 5	04: Label	0C: Envelope	1A: Custom 6	05: Bond	0D: Cardstock	1B: Custom 7	06: Recycled	10: Thick	1C: Custom 8	07: Vellum	15: Custom 1		08: Rough	16: Custom 2																																	
01: Plain	09: Letterhead	17: Custom 3																																																							
02: Transparency	0A: Color	18: Custom 4																																																							
03: Preprinted	0B: Prepunched	19: Custom 5																																																							
04: Label	0C: Envelope	1A: Custom 6																																																							
05: Bond	0D: Cardstock	1B: Custom 7																																																							
06: Recycled	10: Thick	1C: Custom 8																																																							
07: Vellum	15: Custom 1																																																								
08: Rough	16: Custom 2																																																								
(e) Ejection location	01: Face-down output tray																																																								
② Service Call Log	<p>#: Log number 1 to 8 jams are recorded. (If the number of service calls exceeds 8, the oldest log is deleted.) Count.: Number of pages Total page counter at the time of service call Service code: Log code</p>																																																								
③ Maintenance Log	<p>#: Log number 1 to 16 jams are recorded. (If the number of replacement times exceeds 16, the oldest log is deleted.) Count.: Number of pages Total page counter at the time of replacement Item: Log code Two units of 1-byte values indicate a log. First byte 01: Replacement of toner container Second byte 00 : black (fixed)</p>																																																								
④ Counter Log	<p>Jam count Counter display by cause of jam Example J05: 001 Jam05 occurred one time. Call system log Counter display by service call Example C0180: 006 C0180 occurred six times. Replacement log Replacement log display by item Example T00: 001 The toner container was replaced one time.</p>																																																								

Maintenance item No.	Description								
U020	<p>Initializing all data</p> <p>Description Initializes all the backup RAM on the engine board to return to the original settings.</p> <p>Purpose Used when replacing backup RAM on the engine board. After initialization, run U157 “Changing the developing drive time” and U411 “Adjusting the scanner automatically.”</p> <p>Method</p> <ol style="list-style-type: none"> 1. Press the enter key. A selection item appears. 2. Select “Execute” using the up/down cursor keys. 3. Press the enter key. All data in the backup RAM is initialized. When initialization is complete, the machine automatically returns to the same status as when the power switch is turned on. <p>Completion To exit this maintenance item without executing initialization, press the back key. The indication for selecting a maintenance item No. appears.</p>								
U034	<p>Adjusting the print start timing</p> <p>Adjustment See pages 1-6-41 and 42.</p>								
U051	<p>Adjusting the amount of slack in the paper</p> <p>Adjustment See page 1-6-43.</p>								
U060	<p>Adjusting the scanner input properties</p> <p>Description Adjusts the image scanning density.</p> <p>Purpose Used when the entire image appears too dark or light.</p> <p>Method Press the enter key.</p> <p>Setting</p> <ol style="list-style-type: none"> 1. Change the setting using the left/right cursor keys. <table border="1" style="width: 100%; border-collapse: collapse;"> <thead> <tr> <th style="text-align: center;">Display</th> <th style="text-align: center;">Description</th> <th style="text-align: center;">Setting range</th> <th style="text-align: center;">Initial setting</th> </tr> </thead> <tbody> <tr> <td style="text-align: center;">γ Adj. (MONO)</td> <td>Image scanning density</td> <td style="text-align: center;">0 to 23</td> <td style="text-align: center;">12</td> </tr> </tbody> </table> <p style="margin-left: 20px;">Increasing the setting makes the density lower, and decreasing it makes the density higher.</p> <ol style="list-style-type: none"> 2. Press the enter key. The value is set. <p>Test print mode While this maintenance item is being performed, copying from an original can be made in test print mode.</p> <ol style="list-style-type: none"> 1. Press the system menu/counter key. The machine enters the test print mode. 2. Set the original and press the strat key. * The test printing, however, cannot be stopped until the preset number of sheets is printed. 3. To return to the indication for setting, press the system menu/counter key. <p>Completion Press the back key. The indication for selecting a maintenance item No. appears.</p>	Display	Description	Setting range	Initial setting	γ Adj. (MONO)	Image scanning density	0 to 23	12
Display	Description	Setting range	Initial setting						
γ Adj. (MONO)	Image scanning density	0 to 23	12						

Maintenance item No.	Description								
U063	<p>Adjusting the shading position</p> <p>Description Changes the shading position.</p> <p>Purpose Used when white lines continue to appear longitudinally on the image after the shading plate is cleaned. This is due to flaws or stains inside the shading plate. To prevent this problem, the shading position should be changed so that shading is possible without being affected by the flaws or stains.</p> <p>Method Press the enter key.</p> <p>Setting</p> <ol style="list-style-type: none"> 1. Change the setting using the left/right cursor keys. <table border="1" data-bbox="320 611 1382 696"> <thead> <tr> <th>Display</th> <th>Description</th> <th>Setting range</th> <th>Initial setting</th> </tr> </thead> <tbody> <tr> <td>Adjust Data</td> <td>Shading position</td> <td>-5 to +5</td> <td>0</td> </tr> </tbody> </table> <p>Increasing the setting moves the shading position toward the machine left, and decreasing it moves the position toward the machine right.</p> <ol style="list-style-type: none"> 2. Press the enter key. The value is set. <p>Test print mode While this maintenance item is being performed, copying from an original can be made in test print mode.</p> <ol style="list-style-type: none"> 1. Press the system menu/counter key. The machine enters the test print mode. 2. Set the original and press the strat key. <p>* The test printing, however, cannot be stopped until the preset number of sheets is printed.</p> <ol style="list-style-type: none"> 3. To return to the indication for setting, press the system menu/counter key. <p>Completion Press the back key. The indication for selecting a maintenance item No. appears.</p>	Display	Description	Setting range	Initial setting	Adjust Data	Shading position	-5 to +5	0
Display	Description	Setting range	Initial setting						
Adjust Data	Shading position	-5 to +5	0						
U065	<p>Adjusting the scanner magnification</p> <p>Adjustment See pages 1-6-44 and 45.</p>								
U066	<p>Adjusting the leading edge registration for scanning an original on the contact glass</p> <p>Adjustment See page 1-6-46.</p>								
U067	<p>Adjusting the center line for scanning an original on the contact glass</p> <p>Adjustment See page 1-6-47.</p>								
U070	<p>Adjusting the DP magnification</p> <p>Adjustment See pages 1-6-49.</p>								
U071	<p>Adjusting the DP scanning timing</p> <p>Adjustment See pages 1-6-50 and 51.</p>								
U072	<p>Adjusting the DP center line</p> <p>Adjustment See pages 1-6-52.</p>								

Maintenance item No.	Description														
U074	<p>Adjusting the DP input light luminosity</p> <p>Description Adjusts the luminosity of the exposure lamp for scanning originals from the DP.</p> <p>Purpose Used if the exposure amount differs significantly between when scanning an original on the contact glass and when scanning an original from the DP.</p> <p>Method Press the enter key.</p> <p>Setting</p> <ol style="list-style-type: none"> Change the setting using the left/right cursor keys. <table border="1" style="width: 100%; border-collapse: collapse;"> <thead> <tr> <th style="text-align: left;">Display</th> <th style="text-align: left;">Description</th> <th style="text-align: left;">Setting range</th> <th style="text-align: left;">Initial setting</th> </tr> </thead> <tbody> <tr> <td>Adjust Data</td> <td>DP input light luminosity</td> <td>0 to 8</td> <td>1</td> </tr> </tbody> </table> <p>Increasing the setting makes the luminosity higher, and decreasing it makes the luminosity lower.</p> <ol style="list-style-type: none"> Press the enter key. The value is set. <p>Test print mode While this maintenance item is being performed, copying from an original can be made in test print mode.</p> <ol style="list-style-type: none"> Press the system menu/counter key. The machine enters the test print mode. Set the original and press the strat key. * The test printing, however, cannot be stopped until the preset number of sheets is printed. To return to the indication for setting, press the system menu/counter key. <p>Completion Press the back key. The indication for selecting a maintenance item No. appears.</p>	Display	Description	Setting range	Initial setting	Adjust Data	DP input light luminosity	0 to 8	1						
Display	Description	Setting range	Initial setting												
Adjust Data	DP input light luminosity	0 to 8	1												
U087	<p>Turning the DP scanning position adjust mode on/off</p> <p>Description Turns on or off the DP scanning position adjust mode, in which the DP original scanning position is adjusted automatically by determining the presence or absence of dust on the slit glass. Also changes the reference data for identifying dust.</p> <p>Reference In the DP original scanning position adjust mode, the presence or absence of dust is determined by comparing the scan data of the original trailing edge and that taken after the original is conveyed past the DP original scanning position. If dust is identified, the DP original scanning position is adjusted for the following originals.</p> <p>Purpose Used to prevent appearance of black lines due to dust adhering in the original scanning position on the slit glass when the DP is used.</p> <p>Method</p> <ol style="list-style-type: none"> Press the enter key. A selection item appears. Select the item to be set using the up/down cursor keys. <table border="1" style="width: 100%; border-collapse: collapse;"> <thead> <tr> <th style="text-align: left;">Display</th> <th style="text-align: left;">Description</th> </tr> </thead> <tbody> <tr> <td>On/Off</td> <td>Setting the mode on/off</td> </tr> <tr> <td>Data</td> <td>Setting the reference data for identifying dust</td> </tr> </tbody> </table> <p>Setting the mode on/off</p> <ol style="list-style-type: none"> Change the setting using the left/right cursor keys. <table border="1" style="width: 100%; border-collapse: collapse;"> <thead> <tr> <th style="text-align: left;">Setting range</th> <th style="text-align: left;">Initial setting</th> </tr> </thead> <tbody> <tr> <td>OFF/ON</td> <td>On</td> </tr> </tbody> </table> <ol style="list-style-type: none"> Press the enter key. The setting is set. <p>Setting the reference data for identifying dust Available only when the mode is turned on.</p> <ol style="list-style-type: none"> Change the setting using the left/right cursor keys. <table border="1" style="width: 100%; border-collapse: collapse;"> <thead> <tr> <th style="text-align: left;">Setting range</th> <th style="text-align: left;">Initial setting</th> </tr> </thead> <tbody> <tr> <td>10 to 95</td> <td>35</td> </tr> </tbody> </table> <ol style="list-style-type: none"> Press the enter key. The value is set. <p>Completion Press the back key. The indication for selecting a maintenance item No. appears.</p>	Display	Description	On/Off	Setting the mode on/off	Data	Setting the reference data for identifying dust	Setting range	Initial setting	OFF/ON	On	Setting range	Initial setting	10 to 95	35
Display	Description														
On/Off	Setting the mode on/off														
Data	Setting the reference data for identifying dust														
Setting range	Initial setting														
OFF/ON	On														
Setting range	Initial setting														
10 to 95	35														

Maintenance item No.	Description																																												
U089	<p>Outputting a MIP-PG pattern</p> <p>Description Selects and outputs a MIP-PG pattern created in the machine.</p> <p>Purpose When performing respective image printing adjustments, used to check the machine status apart from that of the scanner with a non-scanned output MIP-PG pattern.</p> <p>Method</p> <ol style="list-style-type: none"> 1. Press the enter key. A selection item appears. 2. Select the item to be output using the up/down cursor keys. <table border="1" data-bbox="320 546 1382 719"> <thead> <tr> <th>Display</th> <th>Description</th> </tr> </thead> <tbody> <tr> <td>Gray Scale</td> <td>Outputs the gray PG</td> </tr> <tr> <td>Mono Level</td> <td>Outputs the monochrome PG</td> </tr> <tr> <td>256 level</td> <td>Outputs the 256-level PG</td> </tr> <tr> <td>1dot Level</td> <td>Outputs the 1dot PG</td> </tr> </tbody> </table> <ol style="list-style-type: none"> 3. Press the enter key to enter the selected mode. <p>Method: Gray PG output or 256-level PG output</p> <ol style="list-style-type: none"> 1. Press the up/down cursor keys to select the desired item of gradation processing. <table border="1" data-bbox="320 819 1382 963"> <thead> <tr> <th>Display</th> <th>Description</th> </tr> </thead> <tbody> <tr> <td>Err Diffusion2</td> <td>2-value error diffusion method</td> </tr> <tr> <td>Err Diffusion4</td> <td>4-value error diffusion method</td> </tr> <tr> <td>Dither</td> <td>Dither matrix method</td> </tr> </tbody> </table> <ol style="list-style-type: none"> 2. Press the enter key. 3. Press the up/down cursor keys to select whether output of γ is on or off. <table border="1" data-bbox="320 1032 1382 1144"> <thead> <tr> <th>Display</th> <th>Description</th> </tr> </thead> <tbody> <tr> <td>γ Off</td> <td>Output of γ off</td> </tr> <tr> <td>γ On</td> <td>Output of γ on</td> </tr> </tbody> </table> <ol style="list-style-type: none"> 4. Press the enter key. 5. Press the system menu/counter key. The machine enters the PG pattern output mode. 6. Press the start key. A MIP-PG pattern is output. 7. To return to the indication for setting, press the system menu/counter key. <p>Method: Monochrome PG output</p> <ol style="list-style-type: none"> 1. Change the setting using the left/right cursor keys. <table border="1" data-bbox="320 1335 1382 1420"> <thead> <tr> <th>Description</th> <th>Setting range</th> <th>Initial setting</th> </tr> </thead> <tbody> <tr> <td>Monochrome PG output level</td> <td>0 to 255</td> <td>70</td> </tr> </tbody> </table> <ol style="list-style-type: none"> 2. Press the enter key. The value is set. 3. Press the up/down cursor keys to select the desired item of gradation processing. <table border="1" data-bbox="320 1487 1382 1630"> <thead> <tr> <th>Display</th> <th>Description</th> </tr> </thead> <tbody> <tr> <td>Err Diffusion2</td> <td>2-value error diffusion method</td> </tr> <tr> <td>Err Diffusion4</td> <td>4-value error diffusion method</td> </tr> <tr> <td>Dither</td> <td>Dither matrix method</td> </tr> </tbody> </table> <ol style="list-style-type: none"> 4. Press the enter key. 5. Press the up/down cursor keys to select whether output of γ is on or off. <table border="1" data-bbox="320 1697 1382 1809"> <thead> <tr> <th>Display</th> <th>Description</th> </tr> </thead> <tbody> <tr> <td>γ Off</td> <td>Output of γ off</td> </tr> <tr> <td>γ On</td> <td>Output of γ on</td> </tr> </tbody> </table> <ol style="list-style-type: none"> 6. Press the enter key. 7. Press the system menu/counter key. The machine enters the PG pattern output mode. 8. Press the start key. A MIP-PG pattern is output. 9. To return to the indication for setting, press the system menu/counter key. 	Display	Description	Gray Scale	Outputs the gray PG	Mono Level	Outputs the monochrome PG	256 level	Outputs the 256-level PG	1dot Level	Outputs the 1dot PG	Display	Description	Err Diffusion2	2-value error diffusion method	Err Diffusion4	4-value error diffusion method	Dither	Dither matrix method	Display	Description	γ Off	Output of γ off	γ On	Output of γ on	Description	Setting range	Initial setting	Monochrome PG output level	0 to 255	70	Display	Description	Err Diffusion2	2-value error diffusion method	Err Diffusion4	4-value error diffusion method	Dither	Dither matrix method	Display	Description	γ Off	Output of γ off	γ On	Output of γ on
Display	Description																																												
Gray Scale	Outputs the gray PG																																												
Mono Level	Outputs the monochrome PG																																												
256 level	Outputs the 256-level PG																																												
1dot Level	Outputs the 1dot PG																																												
Display	Description																																												
Err Diffusion2	2-value error diffusion method																																												
Err Diffusion4	4-value error diffusion method																																												
Dither	Dither matrix method																																												
Display	Description																																												
γ Off	Output of γ off																																												
γ On	Output of γ on																																												
Description	Setting range	Initial setting																																											
Monochrome PG output level	0 to 255	70																																											
Display	Description																																												
Err Diffusion2	2-value error diffusion method																																												
Err Diffusion4	4-value error diffusion method																																												
Dither	Dither matrix method																																												
Display	Description																																												
γ Off	Output of γ off																																												
γ On	Output of γ on																																												

Maintenance item No.	Description																												
U089	<p>Method: 1dot PG output</p> <ol style="list-style-type: none"> Change the setting using the left/right cursor keys. <table border="1" style="width: 100%; border-collapse: collapse;"> <thead> <tr> <th style="text-align: left;">Description</th> <th style="text-align: left;">Setting range</th> <th style="text-align: left;">Initial setting</th> </tr> </thead> <tbody> <tr> <td>Number of 1dot pattern</td> <td>1 to 16</td> <td>1</td> </tr> </tbody> </table> <ol style="list-style-type: none"> Press the enter key. The value is set. Press the system menu/counter key. The machine enters the PG pattern output mode. Press the start key. A MIP-PG pattern is output. To return to the indication for setting, press the system menu/counter key. <p>Completion Press the back key while a selection item is displayed. The indication for selecting a maintenance item No. appears.</p>	Description	Setting range	Initial setting	Number of 1dot pattern	1 to 16	1																						
Description	Setting range	Initial setting																											
Number of 1dot pattern	1 to 16	1																											
U101	<p>Setting the other high voltages</p> <p>Description Changes the developing bias clock and the transfer charging output timing.</p> <p>Purpose To check the developing bias clock and the transfer charging output timing. Do not change the preset value.</p> <p>Method Press the enter key. A selection item appears.</p> <p>Setting</p> <ol style="list-style-type: none"> Select the item to be using the up/down cursor keys. Change the setting using the left/right cursor keys. <table border="1" style="width: 100%; border-collapse: collapse;"> <thead> <tr> <th style="text-align: left;">Display</th> <th style="text-align: left;">Description</th> <th style="text-align: left;">Setting range</th> <th style="text-align: left;">Initial setting</th> </tr> </thead> <tbody> <tr> <td>DB_100Hz (CPY)</td> <td>Developing bias clock frequency</td> <td>2 to 255</td> <td>26</td> </tr> <tr> <td>DB_Duty% (CPY)</td> <td>Developing bias clock frequency</td> <td>1 to 99</td> <td>55</td> </tr> <tr> <td>TC Off [10ms]</td> <td>Transfer charging output OFF timing</td> <td>0 to 255</td> <td>48</td> </tr> <tr> <td>TC On [10ms]</td> <td>Transfer charging output ON timing</td> <td>0 to 255</td> <td>42</td> </tr> <tr> <td>DB_100Hz (PRT)</td> <td>Developing bias clock frequency</td> <td>2 to 255</td> <td>24</td> </tr> <tr> <td>DB_Duty% (PRT)</td> <td>Developing bias clock duty</td> <td>1 to 99</td> <td>60</td> </tr> </tbody> </table> <ol style="list-style-type: none"> Press the enter key. The value is set. <p>Completion Press the back key. The indication for selecting a maintenance item No. appears.</p>	Display	Description	Setting range	Initial setting	DB_100Hz (CPY)	Developing bias clock frequency	2 to 255	26	DB_Duty% (CPY)	Developing bias clock frequency	1 to 99	55	TC Off [10ms]	Transfer charging output OFF timing	0 to 255	48	TC On [10ms]	Transfer charging output ON timing	0 to 255	42	DB_100Hz (PRT)	Developing bias clock frequency	2 to 255	24	DB_Duty% (PRT)	Developing bias clock duty	1 to 99	60
Display	Description	Setting range	Initial setting																										
DB_100Hz (CPY)	Developing bias clock frequency	2 to 255	26																										
DB_Duty% (CPY)	Developing bias clock frequency	1 to 99	55																										
TC Off [10ms]	Transfer charging output OFF timing	0 to 255	48																										
TC On [10ms]	Transfer charging output ON timing	0 to 255	42																										
DB_100Hz (PRT)	Developing bias clock frequency	2 to 255	24																										
DB_Duty% (PRT)	Developing bias clock duty	1 to 99	60																										
U130	<p>Initial setting for the developer</p> <p>Description Executes toner install operation.</p> <p>Purpose To operate when replacing the process unit.</p> <p>Method</p> <ol style="list-style-type: none"> Press the enter key. A selection item appears. Select "On" using the up/down cursor keys. Press the enter key. Turning the power switch off and back on. "ADDING TONER" is displayed and installation of toner starts. After approximately 15 minutes, the installation is completed and the machine becomes ready. <p>Completion Press the back key. The indication for selecting a maintenance item No. appears.</p>																												

Maintenance item No.	Description						
U144	<p>Setting toner loading operation</p> <p>Description Sets toner loading operation.</p> <p>Purpose To run when drum filming (background blur in paper edge section) occurs.</p> <p>Method Press the enter key.</p> <p>Setting</p> <ol style="list-style-type: none"> 1. Change the setting using the left/right cursor keys. <table border="1" data-bbox="319 555 1382 667"> <thead> <tr> <th>Setting value</th> <th>Description</th> </tr> </thead> <tbody> <tr> <td>0</td> <td>Toner not loaded</td> </tr> <tr> <td>1</td> <td>Toner loaded</td> </tr> </tbody> </table> <p>Initial setting: 1</p> <ol style="list-style-type: none"> 2. Press the enter key. The setting is set. <p>Completion Press the back key. The indication for selecting a maintenance item No. appears.</p>	Setting value	Description	0	Toner not loaded	1	Toner loaded
Setting value	Description						
0	Toner not loaded						
1	Toner loaded						
U157	<p>Checking/clearing the developing drive time</p> <p>Description Displays the developing drive time for checking or changing a figure.</p> <p>Purpose To enter the developing drive time again after carrying out initialization with U020 and to clear the developing drive time when replacing process unit.</p> <p>Method</p> <ol style="list-style-type: none"> 1. Press the enter key. The developing drive time is displayed in minutes. 2. Change the setting using the left/right cursor keys or numeric keys. Setting range: 0 to 99999 To clear the developing drive time, set the value to 0. 3. Press the enter key. The value is set. <p>Completion Press the back key. The indication for selecting a maintenance item No. appears.</p>						

Maintenance item No.	Description																								
<p>U161</p>	<p>Setting the fixing control temperature</p> <p>Description Changes the fixing control temperature.</p> <p>Purpose Normally no change is necessary. However, can be used to prevent curling or creasing of paper, or solve a fixing problem on thick paper.</p> <p>Method Press the enter key. A selection item appears.</p> <p>Setting</p> <ol style="list-style-type: none"> 1. Select the item to be set using the up/down cursor keys. 2. Change the setting using the left/right cursor keys. <table border="1" data-bbox="304 611 1366 813"> <thead> <tr> <th>Display</th> <th>Description</th> <th>Setting range</th> <th>Initial setting</th> </tr> </thead> <tbody> <tr> <td>First Temp.</td> <td>Primary stabilization fixing temperature</td> <td>100 to 165 (°C)</td> <td>135</td> </tr> <tr> <td>Second Temp.</td> <td>Secondary stabilization fixing temperature</td> <td>100 to 165 (°C)</td> <td>160</td> </tr> <tr> <td>Copy Temp. 1</td> <td>Printing operation temperature 1</td> <td>160 to 220 (°C)</td> <td>190</td> </tr> <tr> <td>Copy Temp. 2</td> <td>Printing operation temperature 2</td> <td>160 to 220 (°C)</td> <td>195</td> </tr> <tr> <td>Temp. 1 Cont. #</td> <td>Number of sheets for fixing control</td> <td>1 to 99</td> <td>5</td> </tr> </tbody> </table> <p>Printing operation temperature 1: Temperature in printing operation at the start of printing Printing operation temperature 2: Temperature in printing operation after the specified number of sheets for fixing control have passed Number of sheets for fixing control: The number of sheets to be counted for switching from printing operation temperature 1 to printing operation temperature 2 The temperatures are to be set such that Secondary stabilization ≥ Primary stabilization.</p> <ol style="list-style-type: none"> 3. Press the enter key. The value is set. <p>Completion Press the back key. The indication for selecting a maintenance item No. appears.</p>	Display	Description	Setting range	Initial setting	First Temp.	Primary stabilization fixing temperature	100 to 165 (°C)	135	Second Temp.	Secondary stabilization fixing temperature	100 to 165 (°C)	160	Copy Temp. 1	Printing operation temperature 1	160 to 220 (°C)	190	Copy Temp. 2	Printing operation temperature 2	160 to 220 (°C)	195	Temp. 1 Cont. #	Number of sheets for fixing control	1 to 99	5
Display	Description	Setting range	Initial setting																						
First Temp.	Primary stabilization fixing temperature	100 to 165 (°C)	135																						
Second Temp.	Secondary stabilization fixing temperature	100 to 165 (°C)	160																						
Copy Temp. 1	Printing operation temperature 1	160 to 220 (°C)	190																						
Copy Temp. 2	Printing operation temperature 2	160 to 220 (°C)	195																						
Temp. 1 Cont. #	Number of sheets for fixing control	1 to 99	5																						
<p>U163</p>	<p>Resetting the fixing problem data</p> <p>Description Resets the detection of a service call code indicating a problem in the fixing section. When a service call concerning the fixing section occurs, open the front top cover with the service call displayed and press the system menu/counter key to enter the maintenance mode.</p> <p>Purpose To prevent accidents due to an abnormally high fixing temperature.</p> <p>Method</p> <ol style="list-style-type: none"> 1. Press the enter key. A selection item appears. 2. Select "Execute" using the up/down cursor keys. 3. Press the enter key. The fixing problem data is initialized. (Four service calls, namely C6000, C6020, C6050, and C6400 are reset.) <p>Completion Press the back key. The indication for selecting a maintenance item No. appears.</p>																								

Maintenance item No.	Description						
<p>U203</p>	<p>Operating DP separately</p> <p>Description Simulates the original conveying operation separately in the DP.</p> <p>Purpose To check the DP.</p> <p>Method</p> <ol style="list-style-type: none"> 1. Press the enter key. A selection item appears. 2. Select the item to using the up/down cursor keys. <table border="1" data-bbox="320 517 1382 629"> <thead> <tr> <th>Display</th> <th>Operation</th> </tr> </thead> <tbody> <tr> <td>DP</td> <td>With paper</td> </tr> <tr> <td>DP (Non P)</td> <td>Without paper (continuous operation)</td> </tr> </tbody> </table> <ol style="list-style-type: none"> 3. Press the start key. The operation starts. * When operation with paper is selected, if no original is set in the DP, this mode cannot be run. When operation without paper is selected, if originals are set in the DP, this mode cannot be run. 4. To stop continuous operation, press the stop/clear key. <p>Completion Press the back key when the operation stops. The indication for selecting a maintenance item No. appears.</p>	Display	Operation	DP	With paper	DP (Non P)	Without paper (continuous operation)
Display	Operation						
DP	With paper						
DP (Non P)	Without paper (continuous operation)						
<p>U207</p>	<p>Checking the operation panel keys</p> <p>Description Checks operation of the operation panel keys.</p> <p>Purpose To check operation of all the keys and LEDs on the operation panel.</p> <p>Method</p> <ol style="list-style-type: none"> 1. Press the enter key. 2. "01" appears and the leftmost LED on the operation panel lights. 3. As the keys on the operation panel are pressed in order from the left to right, the figure shown increases in increments of 1. If there is an LED corresponding to the key pressed, the LED will light. 4. When all keys are pressed, the indication for selecting a maintenance item No. appears. <p>Completion Press the stop/clear key. The indication for selecting a maintenance item No. appears.</p>						
<p>U260</p>	<p>Changing the copy count timing</p> <p>Description Changes the copy count timing for the total counter and other counters.</p> <p>Purpose To be set according to user (copy service provider) request. If a paper jam occurs frequently in the eject section when the number of copies is counted at the time of paper ejection, copies are provided without copy counts. The copy service provider cannot charge for such copying. To prevent this, the copy timing should be made earlier. If a paper jam occurs frequently in the paper conveying or fixing sections when the number of copies is counted before the paper reaches those sections, copying is charged without a copy being made. To prevent this, the copy timing should be made later.</p> <p>Method Press the enter key. A selection item appears.</p> <p>Setting</p> <ol style="list-style-type: none"> 1. Select the copy count timing using the up/down cursor keys. <table border="1" data-bbox="320 1715 1382 1827"> <thead> <tr> <th>Display</th> <th>Description</th> </tr> </thead> <tbody> <tr> <td>Feed</td> <td>When secondary paper feed starts</td> </tr> <tr> <td>Eject</td> <td>When the paper is ejected</td> </tr> </tbody> </table> <ol style="list-style-type: none"> 2. Press the enter key. The setting is set. <p>Completion Press the back key. The indication for selecting a maintenance item No. appears.</p>	Display	Description	Feed	When secondary paper feed starts	Eject	When the paper is ejected
Display	Description						
Feed	When secondary paper feed starts						
Eject	When the paper is ejected						

Maintenance item No.	Description
U403	Adjusting margins for scanning an original on the contact glass Adjustment See page 1-6-48.
U404	Adjusting margins for scanning an original from the DP Adjustment See page 1-6-53.
U411	Adjusting the scanner automatically Description Uses the original for adjustment (P/N: 2A668011) to carry out the automatic adjustment of scanner (scanner center line adjustment, scanner leading edge registration adjustment, magnification of the scanner in the auxiliary scanning direction adjustment, monochrome/color input γ adjustment, and color correction). Purpose To run after replacing the engine board, ISU unit, exposure lamp or platen glass (shading plate). Before carrying out automatic adjustment, input the target values using U425 "Setting the target." Method <ol style="list-style-type: none"> 1. Run U425 "Setting the target" to input the target values. 2. Set the original to be used for adjustment on the platen. 3. Set five or six sheets of blank paper on the original for adjustment that has been set. 4. Press the enter key. A selection item appears. 5. Select "Execute" using the up/down cursor keys. 6. Press the enter key. Adjustment is carried out. * Do not turn the power switch OFF or open/close the cover (turning the safety switch OFF/ON) before automatic adjustment is complete. 7. If the adjustment is successful, "OK" is displayed. If not, "NG" is displayed. * If "NG" is displayed, set the original for adjustment properly again, gently close the original cover, and then carry out the adjustment again. Completion Press the back key. The indication for selecting a maintenance item No. appears.

Maintenance item No.	Description																														
U425	<p>Setting the target</p> <p>Description When running U411 “Adjusting the scanner automatically,” input the color data value of the specified patch written in the LAB value table on the back side of the original for adjustment (P/N: 2A668011). Note that incorrect value input results in improper automatic adjustment.</p> <p>Purpose To run before running U411 “Adjusting the scanner automatically.”</p> <p>Method Press the enter key. A selection item appears.</p> <p>Setting</p> <ol style="list-style-type: none"> 1. Select the item to be set using the up/down cursor keys. 2. Change the setting using the left/right cursor keys or keypad. * Input the values written in the LAB value table on the back side of the original. <table border="1" data-bbox="320 672 1382 1572"> <thead> <tr> <th>Display</th> <th>Description</th> <th>Setting range</th> </tr> </thead> <tbody> <tr> <td>N8.75(L*) N8.75(a*) N8.75(b*)</td> <td>Black N8.75 (L*) target Black N8.75 (a*) target Black N8.75 (b*) target</td> <td>0.0 to +100.0 -200.0 to +200.0 -200.0 to +200.0</td> </tr> <tr> <td>N4.75(L*) N4.75(a*) N4.75(b*)</td> <td>Black N4.75 (L*) target Black N4.75 (a*) target Black N4.75 (b*) target</td> <td>0.0 to +100.0 -200.0 to +200.0 -200.0 to +200.0</td> </tr> <tr> <td>N1.25(L*) N1.25(a*) N1.25(b*)</td> <td>Black N1.25 (L*) target Black N1.25 (a*) target Black N1.25 (b*) target</td> <td>0.0 to +100.0 -200.0 to +200.0 -200.0 to +200.0</td> </tr> <tr> <td>C(L*) C(a*) C(b*)</td> <td>Cyan (L*) target Cyan (a*) target Cyan (b*) target</td> <td>0.0 to +100.0 -200.0 to +200.0 -200.0 to +200.0</td> </tr> <tr> <td>M(L*) M(a*) M(b*)</td> <td>Magenta (L*) target Magenta (a*) target Magenta (b*) target</td> <td>0.0 to +100.0 -200.0 to +200.0 -200.0 to +200.0</td> </tr> <tr> <td>Y(L*) Y(a*) Y(b*)</td> <td>Yellow (L*) target Yellow (a*) target Yellow (b*) target</td> <td>0.0 to +100.0 -200.0 to +200.0 -200.0 to +200.0</td> </tr> <tr> <td>R(L*) R(a*) R(b*)</td> <td>Red (L*) target Red (a*) target Red (b*) target</td> <td>0.0 to +100.0 -200.0 to +200.0 -200.0 to +200.0</td> </tr> <tr> <td>G(L*) G(a*) G(b*)</td> <td>Green (L*) target Green (a*) target Green (b*) target</td> <td>0.0 to +100.0 -200.0 to +200.0 -200.0 to +200.0</td> </tr> <tr> <td>B(L*) B(a*) B(b*)</td> <td>Blue (L*) target Blue (a*) target Blue (b*) target</td> <td>0.0 to +100.0 -200.0 to +200.0 -200.0 to +200.0</td> </tr> </tbody> </table> <ol style="list-style-type: none"> 3. Press the enter key. The value is set. <p>Completion Press the back key. The indication for selecting a maintenance item No. appears.</p>	Display	Description	Setting range	N8.75(L*) N8.75(a*) N8.75(b*)	Black N8.75 (L*) target Black N8.75 (a*) target Black N8.75 (b*) target	0.0 to +100.0 -200.0 to +200.0 -200.0 to +200.0	N4.75(L*) N4.75(a*) N4.75(b*)	Black N4.75 (L*) target Black N4.75 (a*) target Black N4.75 (b*) target	0.0 to +100.0 -200.0 to +200.0 -200.0 to +200.0	N1.25(L*) N1.25(a*) N1.25(b*)	Black N1.25 (L*) target Black N1.25 (a*) target Black N1.25 (b*) target	0.0 to +100.0 -200.0 to +200.0 -200.0 to +200.0	C(L*) C(a*) C(b*)	Cyan (L*) target Cyan (a*) target Cyan (b*) target	0.0 to +100.0 -200.0 to +200.0 -200.0 to +200.0	M(L*) M(a*) M(b*)	Magenta (L*) target Magenta (a*) target Magenta (b*) target	0.0 to +100.0 -200.0 to +200.0 -200.0 to +200.0	Y(L*) Y(a*) Y(b*)	Yellow (L*) target Yellow (a*) target Yellow (b*) target	0.0 to +100.0 -200.0 to +200.0 -200.0 to +200.0	R(L*) R(a*) R(b*)	Red (L*) target Red (a*) target Red (b*) target	0.0 to +100.0 -200.0 to +200.0 -200.0 to +200.0	G(L*) G(a*) G(b*)	Green (L*) target Green (a*) target Green (b*) target	0.0 to +100.0 -200.0 to +200.0 -200.0 to +200.0	B(L*) B(a*) B(b*)	Blue (L*) target Blue (a*) target Blue (b*) target	0.0 to +100.0 -200.0 to +200.0 -200.0 to +200.0
Display	Description	Setting range																													
N8.75(L*) N8.75(a*) N8.75(b*)	Black N8.75 (L*) target Black N8.75 (a*) target Black N8.75 (b*) target	0.0 to +100.0 -200.0 to +200.0 -200.0 to +200.0																													
N4.75(L*) N4.75(a*) N4.75(b*)	Black N4.75 (L*) target Black N4.75 (a*) target Black N4.75 (b*) target	0.0 to +100.0 -200.0 to +200.0 -200.0 to +200.0																													
N1.25(L*) N1.25(a*) N1.25(b*)	Black N1.25 (L*) target Black N1.25 (a*) target Black N1.25 (b*) target	0.0 to +100.0 -200.0 to +200.0 -200.0 to +200.0																													
C(L*) C(a*) C(b*)	Cyan (L*) target Cyan (a*) target Cyan (b*) target	0.0 to +100.0 -200.0 to +200.0 -200.0 to +200.0																													
M(L*) M(a*) M(b*)	Magenta (L*) target Magenta (a*) target Magenta (b*) target	0.0 to +100.0 -200.0 to +200.0 -200.0 to +200.0																													
Y(L*) Y(a*) Y(b*)	Yellow (L*) target Yellow (a*) target Yellow (b*) target	0.0 to +100.0 -200.0 to +200.0 -200.0 to +200.0																													
R(L*) R(a*) R(b*)	Red (L*) target Red (a*) target Red (b*) target	0.0 to +100.0 -200.0 to +200.0 -200.0 to +200.0																													
G(L*) G(a*) G(b*)	Green (L*) target Green (a*) target Green (b*) target	0.0 to +100.0 -200.0 to +200.0 -200.0 to +200.0																													
B(L*) B(a*) B(b*)	Blue (L*) target Blue (a*) target Blue (b*) target	0.0 to +100.0 -200.0 to +200.0 -200.0 to +200.0																													

Maintenance item No.	Description										
<p>U901</p>	<p>Checking/clearing print counts by paper feed locations</p> <p>Description Displays or clears print counts by paper feed locations.</p> <p>Purpose To check the time to replace consumable parts. Also to clear the counts after replacing the consumable parts.</p> <p>Method</p> <ol style="list-style-type: none"> 1. Press the enter key. The print count will be displayed for each paper feed location. <table border="1" data-bbox="304 488 1366 658"> <thead> <tr> <th data-bbox="304 488 683 528">Display</th> <th data-bbox="683 488 1366 528">Paper source</th> </tr> </thead> <tbody> <tr> <td data-bbox="304 528 683 562">Bypass</td> <td data-bbox="683 528 1366 562">MP tray</td> </tr> <tr> <td data-bbox="304 562 683 595">Cassette 1</td> <td data-bbox="683 562 1366 595">Drawer</td> </tr> <tr> <td data-bbox="304 595 683 629">Cassette 2</td> <td data-bbox="683 595 1366 629">Optional drawer</td> </tr> <tr> <td data-bbox="304 629 683 658">All Clear</td> <td data-bbox="683 629 1366 658">Clearing all counts</td> </tr> </tbody> </table> <ol style="list-style-type: none"> 2. Select the paper feed location to clear the count using the up/down cursor keys. To clear all counts, select "All Clear." 3. Press the enter key. The count is cleared. <p>Completion Press the back key. The indication for selecting a maintenance item No. appears.</p>	Display	Paper source	Bypass	MP tray	Cassette 1	Drawer	Cassette 2	Optional drawer	All Clear	Clearing all counts
Display	Paper source										
Bypass	MP tray										
Cassette 1	Drawer										
Cassette 2	Optional drawer										
All Clear	Clearing all counts										
<p>U905</p>	<p>Checking counts by the DP</p> <p>Description Displays the counts of the DP.</p> <p>Purpose To check the use of the DP.</p> <p>Method Press the enter key. The count will be displayed</p> <p>Completion Press the back key. The indication for selecting a maintenance item No. appears.</p>										
<p>U911</p>	<p>Checking/clearing print counts by paper size</p> <p>Description Displays or clears the paper feed count value by paper size.</p> <p>Purpose To check the time to replace consumable parts. Also to clear the counts after replacing the consumable parts.</p> <p>Method</p> <ol style="list-style-type: none"> 1. Press the enter key. The paper feed counts by paper size will be displayed. 2. Select the paper size to clear the count using the up/down cursor keys. To clear all counts, select "All Clear." 3. Press the enter key. The count is cleared. <p>Completion Press the back key. The indication for selecting a maintenance item No. appears.</p>										

Maintenance item No.	Description
U927	<p>Clearing accounting counter</p> <p>Description Clears the total count, scanner count and machine life count. The counts, however, can be cleared only one time. If either of the total count, canner count or machine life count exceeds 1,000, this mode cannot be run.</p> <p>Purpose To start the counters with value 0 when installing the machine.</p> <p>Method</p> <ol style="list-style-type: none"> 1. Press the enter key. A selection item appears. 2. Select "Execute" using the up/down cursor keys. * If the counter has been cleared, "Execute" is not displayed. 3. Press the enter key. The accounting counter is cleared. <p>Completion Press the back key. The indication for selecting a maintenance item No. appears.</p>
U928	<p>Checking the machine life count</p> <p>Description Displays the machine life count for checking a figure.</p> <p>Purpose To check machine status.</p> <p>Method Press the enter key. The machine life count will be displayed</p> <p>Completion Press the stop/clear key. The indication for selecting a maintenance item No. appears.</p>

1-4-2 System settings

In addition to a maintenance function for service, the machine is equipped with a system settings which can be operated by users (mainly by the machine administrator). In this machine system settings, default settings can be changed.

(1) Executing a system setting item

- Executing a system setting item

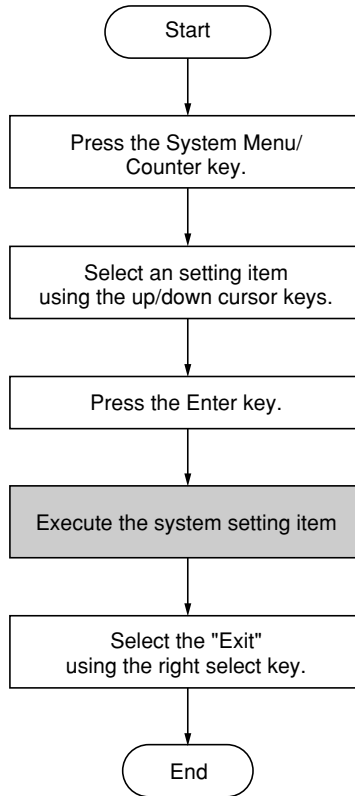

(2) System settings

Adjusting the contrast of the message display

1. Select "Adjust" and press the Enter key.
2. Select "LCD Contrast" and press the Enter key.
3. Select the desired contrast and press the Enter key.

Selecting the message language

1. Select "Common Setting" and press the Enter key.
2. Select "Language" and press the Enter key.
3. Select the language to be used in the message display and press the Enter key.

Setting the default operation mode

1. Select "Common Setting" and press the Enter key.
2. Select "Default Operat." and press the Enter key.
3. Select the desired default operation mode and press the Enter key.

Setting the unit of measurement

1. Select "Common Setting" and press the Enter key.
2. Select "Measurement" and press the Enter key.
3. Select either "Inch" or "mm" and press the Enter key.

Adjusting the copy exposure for the original quality modes

1. Select "Adjust" and press the Enter key.
2. Select "Copy Expo. Adj." and press the Enter key.
3. Select the original quality mode and press the Enter key.
4. Select the desired copy exposure and press the Enter key.

Turning black-line correction ON/OFF

1. Select "Adjust" and press the Enter key.
2. Select "Scan Noise Reduc" and press the Enter key.
3. Select either "On" or "Off" and press the Enter key.

Setting the photo processing method

1. Select "Copy Setting" and press the Enter key.
2. Select "Photo Processing" and press the Enter key.
3. Select the desired processing method and press the Enter key.

Resetting the toner status

1. Select "Common Setting" and press the Enter key.
2. Select "Toner Setting" and press the Enter key.
3. Select "Toner Gauge Rset" and press the Enter key.
4. Select either "Yes" or "No".

Changing the function defaults

1. Select "Function Default" and press the Enter key.
2. Select the default setting and press the Enter key.
3. Select the new default setting and press the Enter key.

Registering destination E-mail addresses under one-touch keys

1. Select "Common Setting" and press the Enter key.
2. Select "One Touch Keys" and press the Enter key.
3. Select the number of the one-touch and press the Enter key.
4. Select "E-mail" and press the Enter key.
5. Enter or revise the e-mail address and then press the Enter key.

Restarting the machine

1. Select "System Setting" and press the Enter key.
2. Select "Restart" and press the Enter key.
3. Select either "Yes" or "No".

Turning individual alarms ON/OFF and/or adjusting the alarm volume

1. Select "Common Setting" and press the Enter key.
2. Select "Sound Setting" and press the Enter key.
3. Select "Buzzer" and press the Enter key.
4. Select "Volume" and press the Enter key.
5. Select the desired volume for the alarms and press the Enter key.
6. Select the desired alarm and press the Enter key.
7. Select either "On" or "Off" and press the Enter key.

Setting the date and time

1. Select "Date/Timer Set." and press the Enter key.
2. Select "Year/Time" and press the Enter key.
3. Register the current year, month and day.
4. Press the Enter key.
5. Register the current hour, minute and second.
6. Press the Enter key.

Setting the time zone

1. Select "Date/Timer Set." and press the Enter key.
2. Select "Time Zone" and press the Enter key.
3. Select the time zone and press the Enter key.

Turning the summer time setting ON/OFF

1. Select "Date/Timer Set." and press the Enter key.
2. Select "Summer Time" and press the Enter key.
3. Select either "On" or "Off" and press the Enter key.

Setting of the panel reset time

1. Select "Date/Timer Set." and press the Enter key.
2. Select "Auto Panel Reset" and press the Enter key.
3. Select either "On" or "Off" and press the Enter key.

Setting of the reset time

1. Select "Date/Timer Set." and press the Enter key.
2. Select "Reset Timer" and press the Enter key.
3. Register the current reset timer and press the Enter key.

Setting the low power time

1. Select "Date/Timer Set." and press the Enter key.
2. Select "Low Power Timer" and press the Enter key.
3. Select the desired time for the low power mode to engage and press the Enter key.

Setting of the sleep time

1. Select "Date/Timer Set." and press the Enter key.
2. Select "Auto sleep" and press the Enter key.
3. Select either "On" or "Off" and press the Enter key.

Setting of the sleep timer

1. Select "Date/Timer Set." and press the Enter key.
2. Select "Sleep Timer" and press the Enter key.
3. Select the desired time for the sleep mode to engage and press the Enter key.

Setting the auto continue recovery time

1. Select "Date/Timer Set." and press the Enter key.
2. Select "Auto Err. Clear" and press the Enter key.
3. Select either "On" or "Off" and press the Enter key.

Setting of the error clear time

1. Select "Date/Timer Set." and press the Enter key.
2. Select "Err. Clear Timer" and press the Enter key.
3. Select the desired recovery time and press the Enter key.

Registering custom paper sizes

1. Select "Common Setting" and press the Enter key.
2. Select "Orig./Paper Set." and press the Enter key.
3. Select "Custom Orig. Size" or "Custom PaperSize", and press the Enter key.
4. Select "Custom" and press the Enter key.
5. Select the height of the original or the copy paper to be registered, and press the Enter key.
6. Select the width of the original or the copy paper to be registered, and press the Enter key.

Settings for the cassettes and MP tray

1. Select "Common Setting" and press the Enter key.
2. Select "Orig./Paper Set." and press the Enter key.
3. Select the desired paper location and press the Enter key.

Registering the paper size and type for cassettes

1. Select "Common Setting" and press the Enter key.
2. Select "Orig./Paper Set." and press the Enter key.
3. Select "Cassette1(2) Set." and press the Enter key.
4. Select "Cassette1(2) Size" and press the Enter key.
5. Select the size of paper and press the Enter key.
6. Select "Cassette1(2) Type" and press the Enter key.
7. Select the type of paper and press the Enter key.

Registering the paper size and type for the MP tray

1. Select "Common Setting" and press the Enter key.
2. Select "Orig./Paper Set." and press the Enter key.
3. Select "MP tray Set." and press the Enter key.
4. Select "MP tray Size" and press the Enter key.
5. Select the size of paper and press the Enter key.
6. Select "MP tray Type" and press the Enter key.
7. Select the type of paper and press the Enter key.

Creating a custom paper type

1. Select "Common Setting" and press the Enter key.
2. Select "Orig./Paper Set." and press the Enter key.
3. Select "Media Type Adj." and press the Enter key.
4. Select the type of paper or select one of the custom settings and press the Enter key.
5. Select the desired paper weight and press the Enter key.
6. Select the desired printing exposure and press the Enter key.
7. Enter the desired name for this custom paper type and press the Enter key.

Selecting the paper feed location

1. Select "Common Setting" and press the Enter key.
2. Select "Orig./Paper Set." and press the Enter key.
3. Select "Def. Paper Input" and press the Enter key.
4. Select the paper feed location and press the Enter key.

Designating the APS (Auto Paper Selection) media type

1. Select "Copy Setting" and press the Enter key.
2. Select "APS Media Type" and press the Enter key.
3. Select the type of paper that will be used in the APS mode and press the Enter key.

Printing out the service settings

1. Select "Service Setting" and press the Enter key.
2. Select "Service Stat Rep" or "Network Stat Rep", and press the Enter key.
3. Select either "Yes" or "No".

1-5-1 Paper misfeed detection

(1) Paper misfeed indication

When a paper misfeed occurs, the machine immediately stops copying or printing and displays the jam location on the operation panel.

To remove paper jammed in the machine, open the face-up output tray, front top cover, front cover or pull the drawer out.

To remove original jammed in the DP, open the DP original cover.

Paper misfeed detection can be reset by opening and closing the respective covers to turn interlock switch off and on.

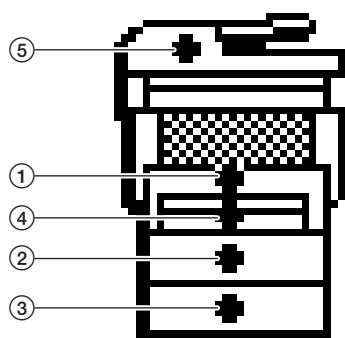

Figure 1-5-1

- ① Misfeed inside the machine
- ② Misfeed in the drawer
- ③ Misfeed in the optional drawer
- ④ Misfeed in the MP tray
- ⑤ Misfeed in the optional DP

(2) Paper misfeed detection conditions

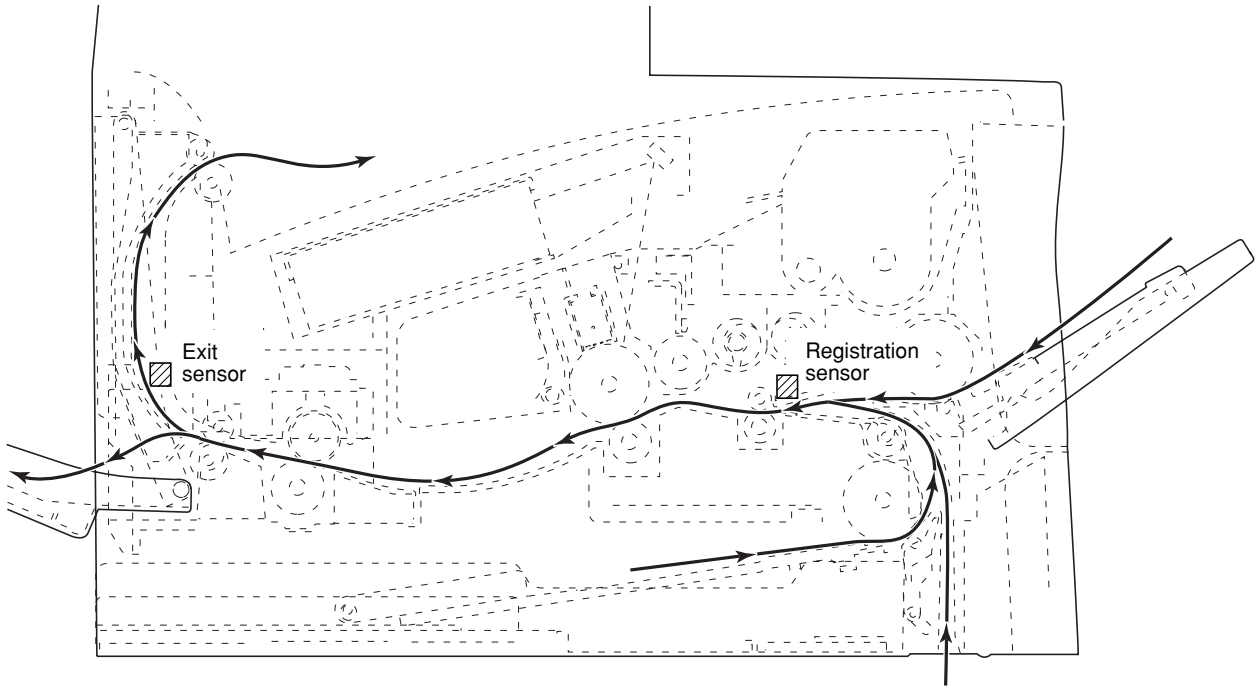

Figure 1-5-2

Section	Jam code	Description	Conditions
System	03	No paper feed	When the power switch is turned on or front top cover is closed, the machine detects activation of the registration sensor or the exit sensor.
	04	Cover open JAM	A cover open state is detected during copying or printing.
	05	Secondary paper feed timeout	When the machine waits for secondary paper feed, 15 s or more have elapsed.
Paper feed section	10	No paper feed from the MP tray	The registration sensor does not turn on within 1350 ms of the MP feed clutch turning on; the clutch is then successively turned off for 1 s and turned back on once, but the sensor again fails to turn on within 1350 ms.
	11	No paper feed from the drawer	The registration sensor does not turn on within 1120 ms of the feed clutch turning on; the clutch is then successively turned off for 1 s and turned back on once, but the sensor again fails to turn on within 1120 ms.
	12	No paper feed from the optional drawer	The registration sensor does not turn on within 1160 ms of the feed clutch turning on; the clutch is then successively turned off for 1 s and turned back on once, but the sensor again fails to turn on within 1160 ms.
	20	Multiple sheets in the MP tray	The registration sensor does not turn off within 5055 ms of the registration clutch turning on (when paper is fed from the MP tray).
	21	Multiple sheets in the drawer	The registration sensor does not turn off within 5055 ms of the registration clutch turning on (when paper is fed from the drawer).
	22	Multiple sheets in the optional drawer	The registration sensor does not turn off within 5055 ms of the registration clutch turning on (when paper is fed from the optional drawer).
Fixing section	40	Misfeed in the fixing section	The exit sensor does not turn on within 2765 ms of the registration clutch turning on.
Exit section	50	Misfeed in the exit section	The exit sensor does not turn off within 2765 ms of the registration sensor turning off.
DP	70	No original feed	When the power switch is turned on, the machine detects activation of the DP timing switch.
			The machine cannot detect activation of the DP timing switch even after 1350 ms elapses since the start of primary paper feed and cannot detect it at the same timing even after 5 times of retry.
	71	An original jam in the original conveying section	The machine cannot detect deactivation of the DP timing switch even after 4227 ms elapses since the start of secondary paper feed.
			The machine detects deactivation of the DP timing switch even after 909 ms elapses since the start of secondary paper feed.
	7A	DP original cover or front top cover open JAM	The machine detects opening of the DP original cover or the front top cover while scanning originals.
	7B	DP open JAM	The machine detects opening of the DP while scanning originals.
7F	Original remaining JAM	When the machine starts scanning of originals, the DP timing switch is on.	

(3) Paper misfeeds**• Main body**

Problem	Causes/check procedures	Corrective measures
(1) A paper jam in the conveying, fixing or exit section is indicated as soon as the power switch is turned on. Jam code 03	A piece of paper torn from paper is caught around registration sensor or exit sensor.	Check visually and remove it, if any.
	Defective registration sensor.	Check if YC8-7 on the engine board remains low when the registration sensor is turned on and off. If it does, replace the registration sensor.
	Defective exit sensor.	Check if YC7-7 on the engine board remains low when the exit sensor is turned on and off. If it does, replace the exit sensor.
(2) A paper jam in the paper feed section is indicated during copying or printing (no paper feed from the MP tray). Jam code 10	Paper on the MP tray is extremely curled.	Change the paper.
	Check if the MP feed roller is deformed.	Check visually and replace any deformed roller.
	Defective registration sensor.	Check if YC8-7 on the engine board remains low when the registration sensor is turned on and off. If it does, replace the registration sensor.
	Check if the MP feed clutch malfunctions.	Check and remedy if necessary.
	Electrical problem with the MP feed clutch.	Check.
(3) A paper jam in the paper feed section is indicated during copying or printing (no paper feed from the drawer). Jam code 11	Paper in the drawer is extremely curled.	Change the paper.
	Check if the feed roller is deformed.	Check visually and replace any deformed roller.
	Defective registration sensor.	Check if YC8-7 on the engine board remains low when the registration sensor is turned on and off. If it does, replace the registration sensor.
	Check if the feed clutch malfunctions.	Check and remedy if necessary.
	Electrical problem with the feed clutch.	Check.
(4) A paper jam in the paper feed section is indicated during copying or printing (no paper feed from the optional drawer). Jam code 12	Paper in the optional drawer is extremely curled.	Change the paper.
	Check if the feed roller of the optional drawer is deformed.	Check visually and replace any deformed roller.
	Defective registration sensor.	Check if YC8-7 on the engine board remains low when the registration sensor is turned on and off. If it does, replace the registration sensor.
	Check if the feed clutch malfunctions.	Check and remedy if necessary.
	Electrical problem with the feed clutch.	Check.

Problem	Causes/check procedures	Corrective measures
(5) A paper jam in the paper feed section is indicated during copying or printing (multiple sheets in the MP tray). Jam code 20	Check if the MP feed roller is deformed.	Check visually and replace any deformed roller.
	Defective registration sensor.	Check if YC8-7 on the engine board remains low when the registration sensor is turned on and off. If it does, replace the registration sensor.
	Check if the registration clutch malfunctions.	Check and remedy if necessary.
	Electrical problem with the registration clutch.	Check.
(6) A paper jam in the paper feed section is indicated during copying or printing (multiple sheets in the drawer). Jam code 21	Check if the feed roller is deformed.	Check visually and replace any deformed roller.
	Defective registration sensor.	Check if YC8-7 on the engine board remains low when the registration sensor is turned on and off. If it does, replace the registration sensor.
	Check if the registration clutch malfunctions.	Check and remedy if necessary.
	Electrical problem with the registration clutch.	Check.
(7) A paper jam in the paper feed section is indicated during copying or printing (multiple sheets in the optional drawer). Jam code 22	Check if the feed roller of the optional drawer is deformed.	Check visually and replace any deformed roller.
	Defective registration sensor.	Check if YC8-7 on the engine board remains low when the registration sensor is turned on and off. If it does, replace the registration sensor.
	Check if the registration clutch malfunctions.	Check and remedy if necessary.
	Electrical problem with the registration clutch.	Check.
(8) A paper jam in the fixing section is indicated during copying or printing (jam in the fixing section). Jam code 40	Defective exit sensor.	Check if YC7-7 on the engine board remains low when the exit sensor is turned on and off. If it does, replace the exit sensor.
	Check if the registration clutch malfunctions.	Check and remedy if necessary.
	Electrical problem with the registration clutch.	Check.
	Check if the upper and lower registration rollers contact each other.	Check visually and remedy if necessary.
	Check if the lower exit roller and exit pulleys contact each other.	Check visually and remedy if necessary.
	Check if the press roller is extremely dirty or deformed.	Clean or replace if necessary.
	Check if the separators are dirty or deformed.	Clean or replace if necessary.

Problem	Causes/check procedures	Corrective measures
(9) A paper jam in the exit section is indicated during copying or printing (jam in the exit section). Jam code 50	Defective registration sensor.	Check if YC8-7 on the engine board remains low when the registration sensor is turned on and off. If it does, replace the registration sensor.
	Defective exit sensor.	Check if YC7-7 on the engine board remains low when the exit sensor is turned on and off. If it does, replace the exit sensor.
	Check if the lower exit roller and exit pulleys contact each other.	Check visually and remedy if necessary.
	Check if the upper exit roller and exit pulleys contact each other.	Check visually and remedy if necessary.

• DP

Problem	Causes/check procedures	Corrective measures
(1) An original jams when the power switch is turned on.	A piece of paper torn from an original is caught around the DP timing switch.	Remove any found.
	Defective DP timing switch.	Check if YC10-6 on the engine board remains low when the DP timing switch is turned on and off. If it does, replace the DP timing switch.
(2) An original jams in the DP is indicated during copying (no original feed). Jam code 70	Defective DP timing switch.	Check if YC10-6 on the engine board remains low when the DP timing switch is turned on and off. If it does, replace the DP timing switch.
	Check if the forwarding pulley or feed pulley is deformed.	Check visually and replace the deformed pulley.
(3) An original jams in the DP during copying (a jam in the original conveying section). Jam code 71	Defective DP timing switch.	Check if YC10-6 on the engine board remains low when the DP timing switch is turned on and off. If it does, replace the DP timing switch.
	Check if the conveying roller or exit roller is deformed.	Check visually and replace the deformed roller.
(4) Original jams frequently.	An original outside the specifications is used.	Use only originals conforming to the specifications.
	The forwarding pulley or feed pulley is dirty with paper powder.	Clean with isopropyl alcohol.
	The conveying roller and conveying pulleys do not contact correctly.	Check and remedy.
	The exit roller and exit pulleys do not contact correctly.	Check and remedy.

1-5-2 Self-diagnosis

(1) Self-diagnostic function

This unit is equipped with a self-diagnostic function. When a problem is detected, copying is disabled. "C" and a number between 0150 and 7990 alternates, indicating the nature of the problem.

After removing the problem, the self-diagnostic function can be reset by turning interlock switch off and back on.

(2) Self diagnostic codes

Code	Contents	Remarks	
		Causes	Check procedures/corrective measures
C0150	Backup memory read/write problem (engine board (KP-5238)) • Read and write data does not match.	Defective backup RAM or engine board (KP-5238).	Replace the engine board (KP-5238) and check for correct operation.
C0160	Backup memory data problem (engine board (KP-5238)) • Data in the specified area of the backup memory does not match the specified values.	Problem with the backup memory data.	Turn interlock switch off and back on and run maintenance item U020 to set the contents of the backup memory data again.
		Defective backup RAM.	If the C0160 is displayed after re-setting the backup memory contents, replace the backup RAM or engine board (KP-5238).
C0170	Accounting count problem • When the power is turned on, the total count and the scan count are abnormal both on the main board (KP-5191) and the engine board (KP-5238).	Defective main board (KP-5191) or engine board (KP-5238).	Replace the main board (KP-5191) or engine board (KP-5238) and check for correct operation.
C0180	Machine number mismatch • When the power is turned on, the machine number does not match between the main board (KP-5191) and the engine board (KP-5238).	Defective main board (KP-5191) or engine board (KP-5238).	Replace the main board (KP-5191) or engine board (KP-5238) and check for correct operation.
C0210	Communication problem between the main board (KP-5191) and engine board (KP-5238) • When the power is turned on, the machine does not detect the low level of SBSY and the high level of SDIR for three seconds.	Poor contact in the connector terminals.	Check the connection of connectors YC7 on the main board (KP-5191) and YC3 on the engine board (KP-5238), and the continuity across the connector terminals. Repair or replace if necessary.
		Defective main board (KP-5191) or engine board (KP-5238).	Replace the main board (KP-5191) or engine board (KP-5238) and check for correct operation.
C0220	Communication problem between the main board (KP-5191) and operation board • There is no reply after 20 retries at communication.	Poor contact in the connector terminals.	Check the connection of connectors YC13 on the main board (KP-5191) and YC3 on the operation board, and the continuity across the connector terminals. Repair or replace if necessary.
		Defective main board (KP-5191) or operation board.	Replace the main board (KP-5191) or operation board and check for correct operation.

Code	Contents	Remarks	
		Causes	Check procedures/corrective measures
C0800	Image processing problem • JAM05 is detected twice.	Defective engine board (KP-5238).	Replace the engine board (KP-5238) and check for correct operation.
C2000	Main motor problem • LOCK ALM signal remains high for 1 s, 1 s after the main motor has turned on.	Poor contact in the main motor connector terminals.	Reinsert the connector. Also check for continuity within the connector cable. If none, remedy or replace the cable.
		Defective main motor rotation control circuit.	Replace the main motor.
		Defective drive transmission system.	Check if the rollers and gears rotate smoothly. If not, grease the bushings and gears. Check for broken gears and replace if any.
C3100	Scanner carriage problem • The home position is not correct when the power is turned on or copying the document placed on the contact glass.	Poor contact of the connector terminals.	Check the connection of connectors YC10, 11 on the engine board (KP-5238) and the continuity across the connector terminals. Repair or replace if necessary.
		Defective scanner home position sensor.	Replace the scanner home position sensor.
		Defective engine board (KP-5238) or scanner board (KP-5063).	Replace the engine board (KP-5238) or scanner board (KP-5063) and check for correct operation.
		Defective scanner motor.	Replace the scanner motor.
C3200	Exposure lamp problem • In indicator check before starting copying, the average value in scanning of the shading plate with the CCD is 128 or more.	Defective scanner board (KP-5063).	Replace the scanner board (KP-5063) and check for correct operation.
		Defective exposure lamp or inverter board.	Replace the exposure lamp or inverter board.
		Incorrect shading position.	Adjust the position of the contact glass (shading plate). If the problem still occurs, replace the scanner home position sensor.
		Poor contact of the connector terminals.	Check the connection of connector YC7 on the scanner board (KP-5063), and the continuity across the connector terminals. Repair or replace if necessary.

Code	Contents	Remarks	
		Causes	Check procedures/corrective measures
C4000	Polygon motor synchronization problem <ul style="list-style-type: none"> The polygon motor does not reach the stable speed within 15 s of the START signal turning on. 	Poor contact in the polygon motor connector terminals.	Reinsert the connector. Also check for continuity within the connector cable. If none, remedy or replace the cable.
		Defective polygon motor.	Replace the LSU.
		Defective engine board (KP-5238).	Replace the engine board (KP-5238) and check for correct operation.
C4010	Polygon motor steady-state problem <ul style="list-style-type: none"> The polygon motor rotation is not stable for 5 s after the polygon motor rotation has been stabilized. 	Poor contact in the polygon motor connector terminals.	Reinsert the connector. Also check for continuity within the connector cable. If none, remedy or replace the cable.
		Defective polygon motor.	Replace the LSU.
		Defective engine board (KP-5238).	Replace the engine board (KP-5238) and check for correct operation.
C6000	Broken fixing heater wire <ul style="list-style-type: none"> In fixing warm-up, the time to reach 50°C/122 °F exceeds 13.5 s, the time to reach 100°C/212 °F exceeds 10 s, the time to reach the primary stabilization exceeds 10 s or the time to reach the secondary stabilization exceeds 24 s. 	Poor contact in the thermistor connector terminals.	Check the connection of connector YC4 on the power supply board and the continuity across the connector terminals. Repair or replace if necessary.
		Thermistor installed incorrectly.	Check and reinstall if necessary.
		Thermal cutout triggered.	Check for continuity. If none, replace the thermal cutout.
		Heater lamp installed incorrectly.	Check and reinstall if necessary.
		Broken heater lamp wire.	Check for continuity. If none, replace the heater lamp.
C6020	Abnormally high fixing unit thermistor temperature <ul style="list-style-type: none"> The fixing temperature exceeds 230°C/446 °F for 40 ms. 	Shorted thermistor.	Measure the resistance. If it is 0 Ω, replace the thermistor.
		Broken heater control circuit on the power supply board.	Replace the power supply board and check for correct operation.

Code	Contents	Remarks	
		Causes	Check procedures/corrective measures
C6050	Abnormally low fixing unit thermistor temperature <ul style="list-style-type: none"> The fixing temperature remains below 90°C/194°F for 1 s. 	Poor contact in the thermistor connector terminals.	Check the connection of connector YC4 on the power supply board and the continuity across the connector terminals. Repair or replace if necessary.
		Broken thermistor wire.	Measure the resistance. If it is $\infty \Omega$, replace the thermistor.
		Thermistor installed incorrectly.	Check and reinstall if necessary.
		Thermal cutout triggered.	Check for continuity. If none, replace the thermal cutout.
		Heater lamp installed incorrectly.	Check and reinstall if necessary.
		Broken heater lamp wire.	Check for continuity. If none, replace the heater lamp.
C6400	Zero-crossing signal problem <ul style="list-style-type: none"> The engine board (KP-5238) does not detect the zero-crossing signal for the time specified below. At power-on: 3 s Others: 5 s 	Poor contact in the connector terminals.	Check the connection of connectors YC7 on the engine board (KP-5238) and YC2 on the power supply board, and the continuity across the connector terminals. Repair or replace if necessary.
		Defective power supply board.	Check if the zero-crossing signal is output from YC2-11 on the power supply board. If not, replace the power supply board.
		Defective engine board (KP-5238).	Replace the engine board (KP-5238) if C6400 is detected while YC2-11 on the power supply board outputs the zero-crossing signal.
C7800	Broken external temperature thermistor <ul style="list-style-type: none"> The input voltage is 0.5 V or less. 	Poor contact in the operation board connector terminals.	Reinsert the connector. Also check for continuity within the connector cable. If none, remedy or replace the cable.
		Defective external temperature thermistor.	Replace the operation board and check for correct operation.
C7810	Short-circuited external temperature thermistor <ul style="list-style-type: none"> The input voltage is 4.5 V or more. 	Poor contact in the operation board connector terminals.	Reinsert the connector. Also check for continuity within the connector cable. If none, remedy or replace the cable.
		Defective external temperature thermistor.	Replace the operation board and check for correct operation.

Code	Contents	Remarks	
		Causes	Check procedures/corrective measures
C7980	<p>Waste toner reservoir overflow problem (when the total number of copies is less than 100 thousand sheets)</p> <ul style="list-style-type: none"> After E31 is displayed, 1,000 sheets are copied. Or waste toner exceeds 5 g. 	Defective waste toner sensor or engine board (KP-5238).	<p>Shake the process unit from side to side and turn the power switch off and then on. If the problem cannot be solved, replace the process unit.</p> <p>After replacing the process unit, turn the power switch off and then on. If the problem cannot be solved, replace the waste toner sensor or the engine board (KP-5238).</p>
C7990	<p>Waste toner reservoir overflow problem (when the total number of copies is 100 thousand sheets or more)</p> <ul style="list-style-type: none"> After E31 is displayed, 1,000 sheets are copied. Or waste toner exceeds 5 g. 	Defective waste toner sensor or engine board (KP-5238).	<p>Shake the process unit from side to side and turn the power switch off and then on. If the problem cannot be solved, replace the process unit.</p> <p>After replacing the process unit, turn the power switch off and then on. If the problem cannot be solved, replace the waste toner sensor or the engine board (KP-5238).</p>
CF- - -	<p>Controller system error</p> <ul style="list-style-type: none"> After "Call for Service person" is indicated, the error can be cleared by turning the power switch off and then on. 	Defective main board (KP-5191).	If this error occurs again even after the power switch is turned off and then on again, replace the main board (KP-5191) and check for correct operation.

1-5-3 Image formation problems

(1) No image appears (entirely white).



See page 1-5-14

(2) No image appears (entirely black).



See page 1-5-14

(3) Image is too light.



See page 1-5-15

(4) Background is visible.

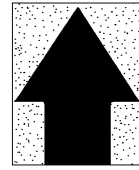

See page 1-5-15

(5) A white line appears longitudinally.



See page 1-5-15

(6) A black line appears longitudinally.



See page 1-5-16

(7) A black line appears laterally.

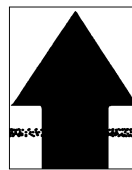

See page 1-5-16

(8) One side of the print image is darker than the other.

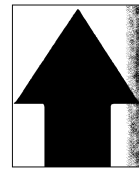

See page 1-5-16

(9) Black dots appear on the image.



See page 1-5-17

(10) Image is blurred.



See page 1-5-17

(11) The leading edge of the image is consistently misaligned with the original.



See page 1-5-17

(12) Paper creases.



See page 1-5-18

(13) Offset occurs.

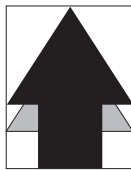

See page 1-5-18

(14) Image is partly missing.



See page 1-5-18

(15) Fixing is poor.



See page 1-5-19

(16) Image center does not align with the original center.



See page 1-5-19

2DD

(1) No image appears (entirely white).

Causes

1. No transfer charging.

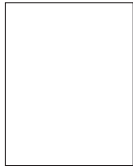

Causes	Check procedures/corrective measures
1. No transfer charging.	
A. The connector terminals of the high voltage board make poor contact.	Reinsert the connector. Also check for continuity within the connector cable. If none, remedy or replace the cable.
B. Defective engine board (KP-5238).	Replace the engine board (KP-5238) and check for correct operation.
C. Defective high voltage board.	Replace the high voltage board and check for correct operation.

(2) No image appears (entirely black).

Causes

1. No main charging.
2. Exposure lamp fails to light.



Causes	Check procedures/corrective measures
1. No main charging.	
A. Broken main charger wire.	Replace the process unit.
B. Leaking main charger housing.	Replace the process unit.
C. The connector terminals of the high voltage board make poor contact.	Reinsert the connector. Also check for continuity within the connector cable. If none, remedy or replace the cable.
D. Defective engine board (KP-5238).	Replace the engine board (KP-5238) and check for correct operation.
E. Defective high voltage board.	Replace the high voltage board and check for correct operation.
2. Exposure lamp fails to light.	
A. The connector terminals of the exposure lamp make poor contact.	Reinsert the connector. Also check for continuity within the connector cable. If none, remedy or replace the cable.
B. Defective CCD board (KP-5252).	Replace the CCD board (KP-5252) and check for correct operation.
C. Defective scanner board (KP-5063).	Replace the scanner board (KP-5063) and check for correct operation.
D. Defective engine board (KP-5238).	Replace the engine board (KP-5238) and check for correct operation.

(3) Image is too light.



Causes

1. Insufficient toner.
2. Deteriorated developer.
3. Dirty or deteriorated drum.

Causes	Check procedures/corrective measures
1. Insufficient toner.	If the add toner indicator lights, replace the toner container.
2. Deteriorated developer.	Replace the process unit.
3. Dirty or deteriorated drum.	Replace the process unit.

(4) Background is visible.

Causes

1. Deteriorated developer.

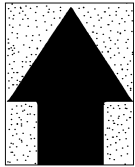

Causes	Check procedures/corrective measures
1. Deteriorated developer.	Replace the process unit.

(5) A white line appears longitudinally.

Causes

1. Dirty or flawed main charger wire.
2. Foreign matter in the developing section.
3. Flawed drum.
4. Dirty shading plate.



Causes	Check procedures/corrective measures
1. Dirty or flawed main charger wire.	Replace the process unit.
2. Foreign matter in the developing section.	Replace the process unit.
3. Flawed drum.	Replace the process unit.
4. Dirty shading plate.	Clean the shading plate.

(6) A black line appears longitudinally.

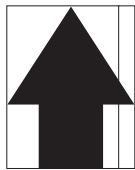

Causes

1. Dirty contact glass.
2. Dirty or flawed drum.
3. Deformed or worn cleaning blade.
4. Dirty scanner mirror.

Causes	Check procedures/corrective measures
1. Dirty contact glass.	Clean the contact glass.
2. Dirty or flawed drum.	Replace the process unit.
3. Deformed or worn cleaning blade.	Replace the process unit.
4. Dirty scanner mirror.	Clean the scanner mirror.

(7) A black line appears laterally.

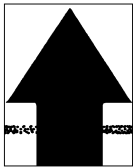

Causes

1. Flawed drum.
2. Dirty developing section.
3. Leaking main charger housing.

Causes	Check procedures/corrective measures
1. Flawed drum.	Replace the process unit.
2. Dirty developing section.	Replace the process unit.
3. Leaking main charger housing.	Replace the process unit.

(8) One side of the print image is darker than the other.

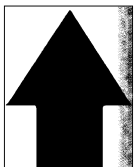

Causes

1. Dirty main charger wire.
2. Defective exposure lamp.

Causes	Check procedures/corrective measures
1. Dirty main charger wire.	Replace the process unit.
2. Defective exposure lamp.	Check if the exposure lamp light is distributed evenly. If not, replace the exposure lamp (see page 1-6-34).

(9) Black dots appear on the image.



Causes

1. Dirty or flawed drum.
2. Dirty contact glass.
3. Deformed or worn cleaning blade.

Causes	Check procedures/corrective measures
1. Dirty or flawed drum.	Replace the process unit.
2. Dirty contact glass.	Clean the contact glass.
3. Deformed or worn cleaning blade.	Replace the process unit.

(10) Image is blurred.

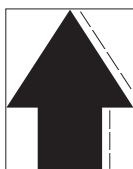

Causes

1. Deformed press roller.
2. Paper conveying section drive problem.

Causes	Check procedures/corrective measures
1. Deformed press roller.	Replace the press roller (see page 1-6-26).
2. Paper conveying section drive problem.	Check the gears and belts and, if necessary, grease them.

(11) The leading edge of the image is consistently misaligned with the original.



Causes

1. Misadjusted leading edge registration.
2. Misadjusted scanner leading edge registration.

Causes	Check procedures/corrective measures
1. Misadjusted leading edge registration.	Readjust the leading edge registration (see pages 1-6-41).
2. Misadjusted scanner leading edge registration.	Readjust the scanner leading edge registration (see page 1-6-46).

2DD

(12) Paper creases.

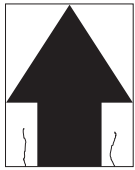

Causes

1. Paper curled.
2. Paper damp.

Causes	Check procedures/corrective measures
1. Paper curled.	Check the paper storage conditions.
2. Paper damp.	Check the paper storage conditions.

(13) Offset occurs.

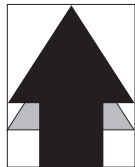

Causes

1. Defective cleaning blade.

Causes	Check procedures/corrective measures
1. Defective cleaning blade.	Replace the process unit.

(14) Image is partly missing.



Causes

1. Paper damp.
2. Paper creased.
3. Flawed drum.

Causes	Check procedures/corrective measures
1. Paper damp.	Check the paper storage conditions.
2. Paper creased.	Replace the paper.
3. Flawed drum.	Replace the process unit.

(15) Fixing is poor.

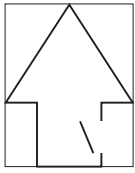

Causes

1. Wrong paper.
2. Flawed press roller.

Causes	Check procedures/corrective measures
1. Wrong paper.	Check if the paper meets specifications.
2. Flawed press roller.	Replace the press roller (see page 1-6-26).

(16) Image center does not align with the original center.

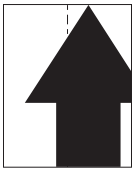

Causes

1. Misadjusted center line of image printing.
2. Misadjusted scanner center line.
3. Original placed incorrectly.

Causes	Check procedures/corrective measures
1. Misadjusted center line of image printing.	Readjust the center line of image printing (see pages 1-6-42).
2. Misadjusted scanner center line.	Readjust the scanner center line (see page 1-6-47).
3. Original placed incorrectly.	Place the original correctly.

1-5-4 Electrical problems

Problem	Causes	Check procedures/corrective measures
(1) The machine does not operate when the power switch is turned on.	No electricity at the power outlet.	Measure the input voltage.
	The power cord is not plugged in properly.	Check the contact between the power plug and the outlet.
	The front cover is not closed completely.	Check the front cover.
	Broken power cord.	Check for continuity. If none, replace the cord.
	Defective power switch.	Check for continuity across the contacts. If none, replace the power switch.
	Blown fuse in the power supply board.	Check for continuity. If none, remove the cause of blowing and replace the fuse.
	Defective interlock switch.	Check for continuity across the contacts of switch. If none, replace the switch.
	Defective power supply board.	With AC present, check for 24 V DC at YC2-6 and 5 V DC at YC2-1 on the power supply board. If none, replace the power supply board.
(2) The main motor does not operate (C2000).	Poor contact in the main motor connector terminals.	Reinsert the connector. Also check for continuity within the connector cable. If none, remedy or replace the cable.
	Broken main motor gear.	Check visually and replace the main motor if necessary.
	Defective main motor.	Check if the main motor operates and replace the main motor if necessary.
	Defective engine board (KP-5238).	Check if YC4-9 on the engine board (KP-5238) go low when the main motor is operated. If not, replace the engine board (KP-5238).
(3) The scanner motor does not operate.	Broken scanner motor coil.	Check for continuity across the coil. If none, replace the scanner motor.
	Poor contact in the scanner motor connector terminals.	Reinsert the connector. Also check for continuity within the connector cable. If none, remedy or replace the cable.
(4) Cooling fan does not operate.	Broken Cooling fan coil.	Check for continuity across the coil. If none, replace Cooling fan.
	Poor contact in the Cooling fan connector terminals.	Reinsert the connector. Also check for continuity within the connector cable. If none, remedy or replace the cable.
(5) The feed clutch does not operate.	Broken feed clutch coil.	Check for continuity across the coil. If none, replace the feed clutch.
	Poor contact in the feed clutch connector terminals.	Reinsert the connector. Also check for continuity within the connector cable. If none, remedy or replace the cable.
	Defective engine board (KP-5238).	Check if YC4-1 on the engine board (KP-5238) goes low when the feed clutch is turned on. If not, replace the engine board (KP-5238).

Problem	Causes	Check procedures/corrective measures
(6) The MP feed clutch does not operate.	Broken MP feed clutch coil.	Check for continuity across the coil. If none, replace the MP feed clutch.
	Poor contact in the MP feed clutch connector terminals.	Reinsert the connector. Also check for continuity within the connector cable. If none, remedy or replace the cable.
	Defective engine board (KP-5238).	Check if YC5-2 on the engine board (KP-5238) goes low when the MP feed clutch is turned on. If not, replace the engine board (KP-5238).
(7) The registration clutch does not operate.	Broken registration clutch coil.	Check for continuity across the coil. If none, replace the registration clutch.
	Poor contact in the registration clutch connector terminals.	Reinsert the connector. Also check for continuity within the connector cable. If none, remedy or replace the cable.
	Defective engine board (KP-5238).	Check if YC6-2 on the engine board (KP-5238) goes low when the registration clutch is turned on. If not, replace the engine board (KP-5238).
(8) The eraser lamp does not turn on.	Poor contact in the eraser lamp connector terminals.	Reinsert the connector. Also check for continuity within the connector cable. If none, remedy or replace the cable.
	Defective eraser lamp.	Check for continuity. If none, replace the eraser lamp.
	Defective engine board (KP-5238).	If the eraser lamp turns on when YC14-2 on the engine board (KP-5238) is held low, replace the engine board (KP-5238).
(9) The exposure lamp does not turn on.	Poor contact in the exposure lamp connector terminals.	Reinsert the connector. Also check for continuity within the connector cable. If none, remedy or replace the cable.
	Defective scanner board (KP-5063).	Check if the exposure lamp turns on with YC7-1 and YC7-2 on the scanner board (KP-5063) goes low. If not, replace the scanner board (KP-5063).
	Defective engine board (KP-5238).	Check if the exposure lamp turns on with YC11-10 on the engine board (KP-5238) goes low. If not, replace the engine board (KP-5238).
(10) The exposure lamp does not turn off.	Defective scanner board (KP-5063).	Check if the exposure lamp turns on with YC7-1 and YC7-2 on the scanner board (KP-5063) goes low. If not, replace the scanner board (KP-5063).
	Defective engine board (KP-5238).	Check if the exposure lamp turns on with YC11-10 on the engine board (KP-5238) goes low. If not, replace the engine board (KP-5238).
(11) The heater lamp does not turn on.	Broken wire in heater lamp.	Check for continuity across heater lamp. If none, replace the heater lamp.
	Thermal cutout triggered.	Check for continuity across thermal cutout. If none, remove the cause and replace the thermal cutout.
(12) The heater lamp does not turn off.	Broken heater lamp wire.	Measure the resistance. If it is $\infty\Omega$, replace the thermistor.
	Dirty sensor part of the thermistor.	Check visually and clean the thermistor sensor parts.

Problem	Causes	Check procedures/corrective measures
(13) Main charging is not performed.	Broken main charger wire.	See page 1-5-14.
	Leaking main charger housing.	
	Poor contact in the high voltage board connector terminals.	
	Defective engine board (KP-5238).	
	Defective high voltage board.	
(14) Transfer charging is not performed.	Poor contact in the high voltage board connector terminals.	See page 1-5-14.
	Defective engine board (KP-5238).	
	Defective high voltage board.	
(15) A paper jam in the paper feed or exit section is indicated when the power switch is turned on.	A piece of paper torn from paper is caught around registration sensor or exit sensor.	Check and remove if any.
	Defective registration sensor.	Check if YC8-7 on the engine board remains low when the registration sensor is turned on and off. If it does, replace the registration sensor.
	Defective exit sensor.	Check if YC7-7 on the engine board remains low when the exit sensor is turned on and off. If it does, replace the exit sensor.
(16) The message requesting cover to be closed is displayed when the front cover is closed.	Poor contact in the connector terminals of interlock switch.	Reinsert the connector. Also check for continuity within the connector cable. If none, remedy or replace the cable.
	Defective interlock switch.	Check for continuity across switch. If there is no continuity when the switch is on, replace it.
(17) Others.	Wiring is broken, shorted or makes poor contact.	Check for continuity. If none, repair.
	Noise.	Locate the source of noise and remove.

1-5-5 Mechanical problems

Problem	Causes/check procedures	Corrective measures
(1) No primary paper feed.	Check if the surfaces of the feed roller and MP feed roller are dirty with paper powder.	Clean with isopropyl alcohol.
	Check if the feed roller and MP feed roller are deformed.	Check visually and replace any deformed rollers (see page 1-6-5, 6).
	Electrical problem with the feed clutch and MP feed clutch.	See pages 1-5-20, 21.
(2) No secondary paper feed.	Check if the surfaces of the upper and lower registration rollers are dirty with paper powder.	Clean with isopropyl alcohol.
	Electrical problem with the registration clutch.	See page 1-5-21.
(3) Skewed paper feed.	Deformed width guide in a drawer.	Repair or replace if necessary .
(4) The scanner does not travel.	The scanner motor malfunctions.	See page 1-5-20.
(5) Multiple sheets of paper are fed at one time.	Deformed drawer claw.	Check the drawer claw visually and correct or replace if necessary.
(6) Paper jams.	Check if the paper is curled.	Change the paper.
	Deformed guides along the paper conveying path.	Check visually and replace any deformed guides.
	Check if the contact between the upper and lower registration rollers is correct.	Check visually and remedy if necessary.
	Check if the press roller is extremely dirty or deformed.	Clean or replace the press roller.
	Check if the contact between the heat roller and its separation claws is correct.	Repair if any springs are off the separation claws.
(7) Abnormal noise is heard.	Check if the rollers and gears operate smoothly.	Grease the bearings and gears.
	Check if the following electromagnetic clutches are installed correctly: feed clutch, MP feed clutch and registration clutch.	Correct.

1-6-1 Precautions for assembly and disassembly

(1) Precautions

- Be sure to turn the power switch off and disconnect the power plug before starting disassembly.
- When handling PCBs, do not touch connectors with bare hands or damage the board.
- Do not touch any PCB containing ICs with bare hands or any object prone to static charge.
- Use only the specified parts to replace the fixing unit thermostat. Never substitute electric wires, as the machine may be seriously damaged.
- Do not perform aging without the waste toner tank installed during maintenance service.
- Use the following testers when measuring voltages:
 - Hioki 3200
 - Sanwa MD-180C
 - Sanwa YX-360TR
 - Beckman TECH300
 - Beckman DM45
 - Beckman 330*
 - Beckman 3030*
 - Beckman DM850*
 - Fluke 8060A*
 - Arlec DMM1050
 - Arlec YF1030C
- * Capable of measuring RMS values.
- Prepare the following as test originals:
 1. NTC (new test chart)
 2. NPTC (newspaper test chart)

1-6-2 Removing the process unit

1. Open the front top cover.
2. Open the front cover.
3. Lift the process unit together with the toner container out of the machine.

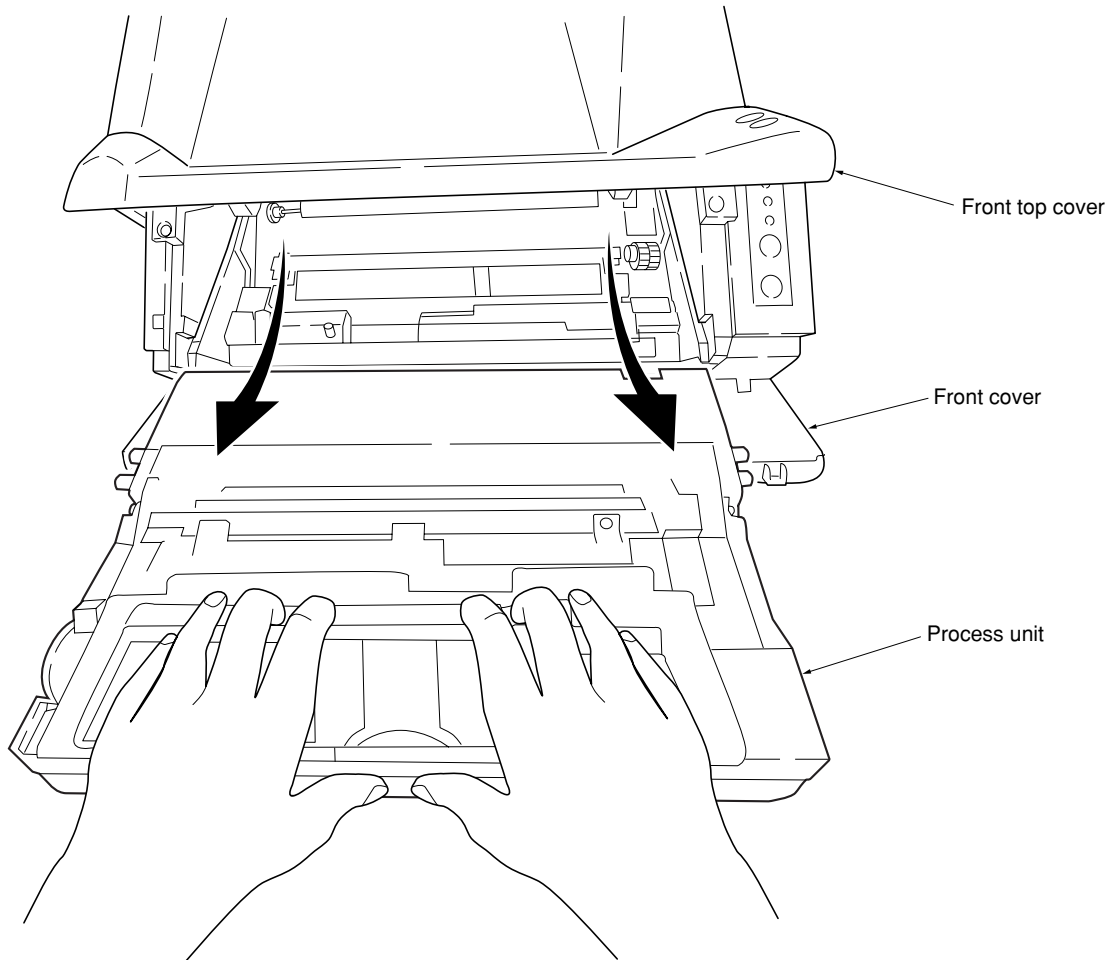

Figure 1-6-1 Removing the process unit

CAUTIONS

- After removing the process unit, seal it in the protective bag and place it on flat surface. Do not place the process unit in a dusty area.
- Do not give impact to the process unit.
- Do not place floppy disks near the process unit.
- If the process unit is replaced for some reason, the toner installation mode must be run.
 1. Run maintenance mode U157 to clear the developing drive time.
 2. Run maintenance mode U130 to turn the setting "ON."
 3. Turn the power switch off and then on again.
 The toner installation mode starts to add toner to the developing section of the process unit (approximately 15 minutes).
 - * Run the toner installation mode only when you have replaced the process unit with a new one. (Do not run it when toner remains in the process unit.)

1-6-3 Removing the principal outer covers

(1) Removing the front top cover/face-down output tray

1. Remove the one screw and then remove the memory cover.
2. Remove the one screw and then remove the rear cover.

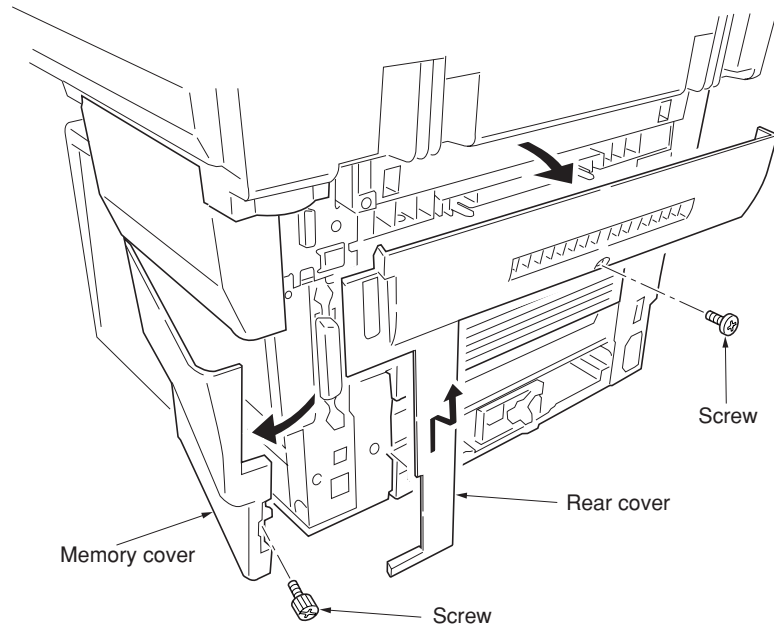

Figure 1-6-2 Removing the memory cover and rear cover

3. While unlatching the two latches and then remove the front top cover/face-down output tray.

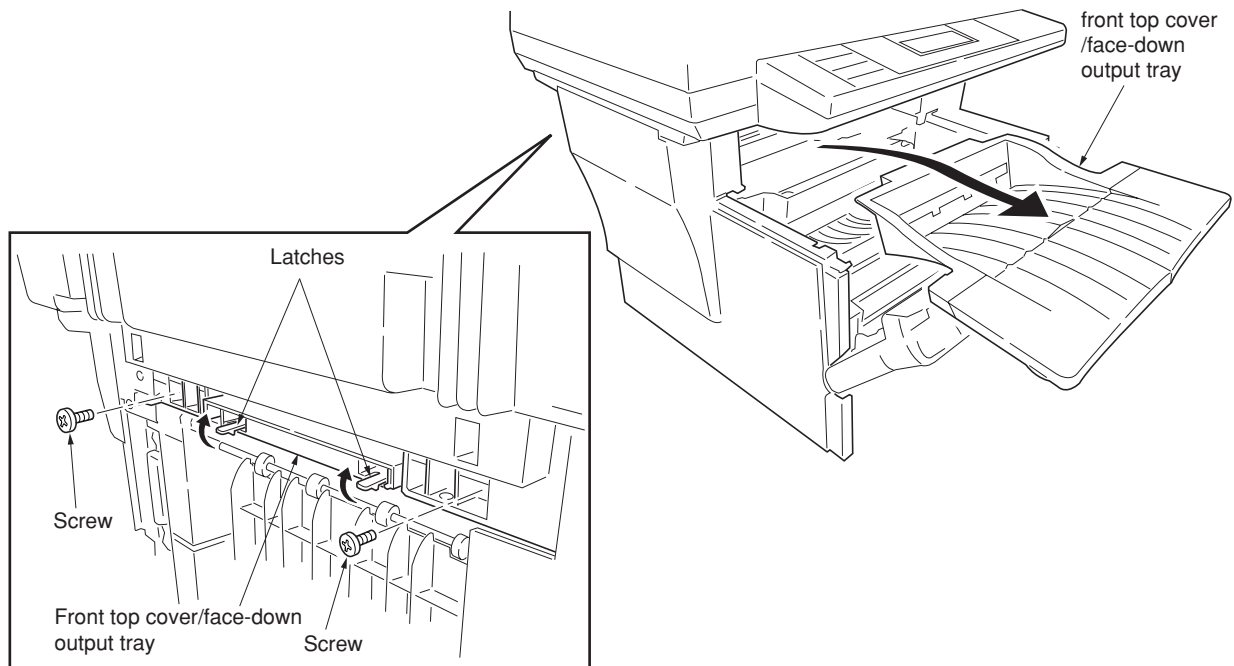

Figure 1-6-3 Removing the front top cover/face-down output tray

(2) Removing the right cover

1. Remove the front top cover/face-down output tray (See page1-6-3).
2. Remove the memory cover (See page 1-6-3).
3. Unlatch the snaps and hook, remove the right cover.

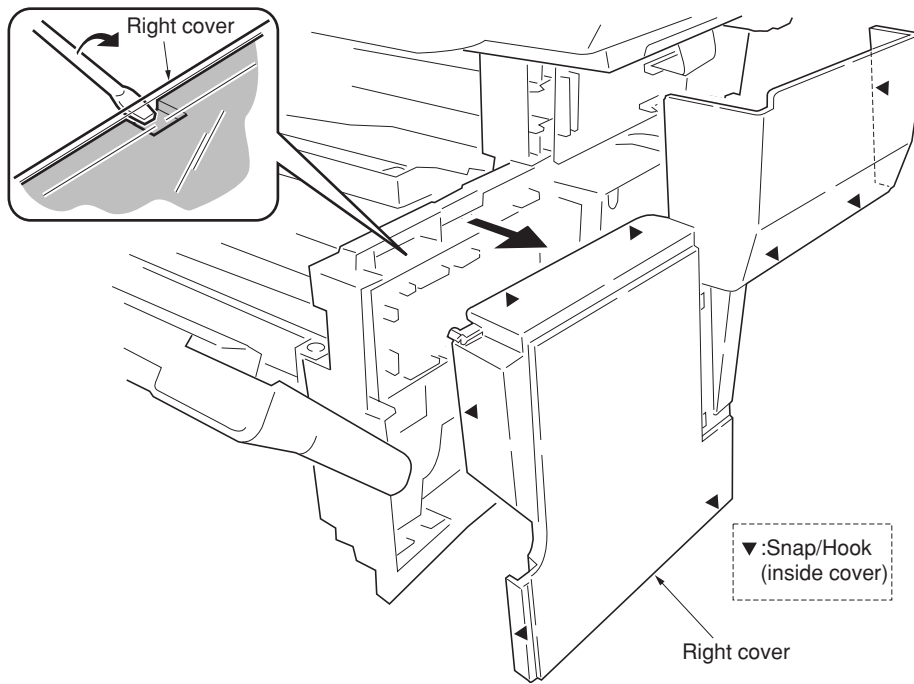

Figure 1-6-4 Removing the right cover

(3) Removing the left cover

1. Remove the front top cover/face-down output tray (See page1-6-3).
2. Unlatch the snaps and hooks, remove the left cover.

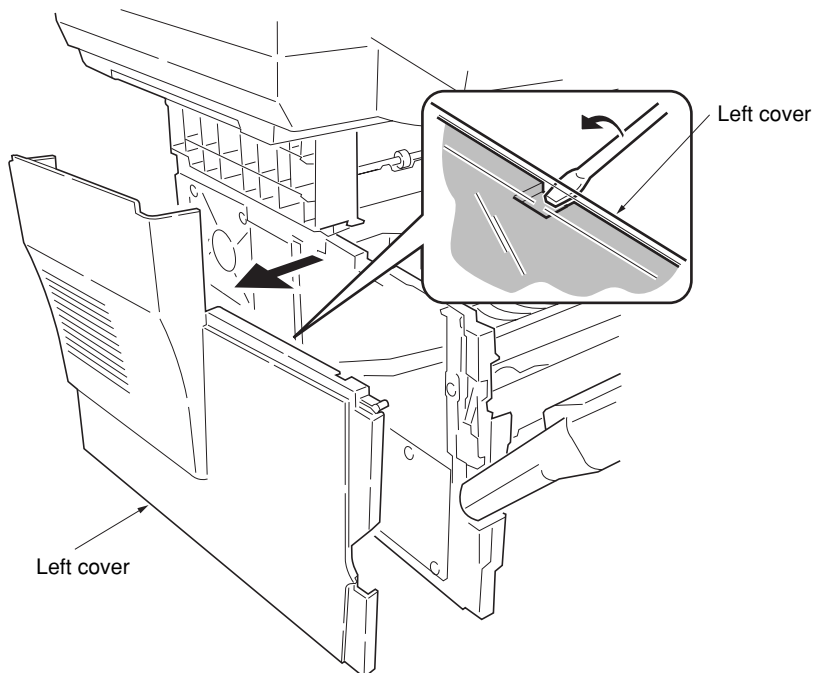

Figure 1-6-5 Removing the left cover

1-6-4 Removing the feed roller

CAUTION

When refit the feed roller, fit the D-cut shaft into the D-shape hole of the feed roller.

1. Remove the paper cassette and the process unit (See page 1-6-2).
2. Stand the machine the front side up.
3. Move the feed roller in the direction (A), and remove the feed roller.

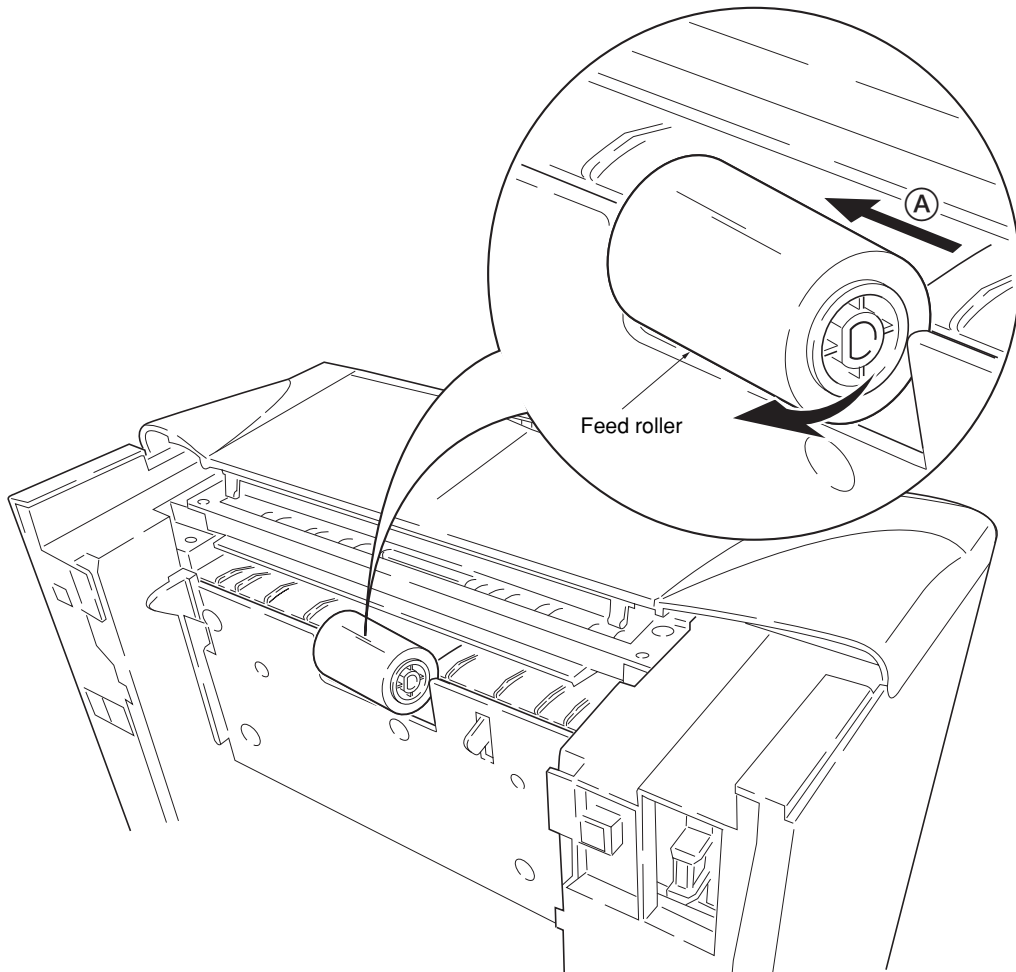

Figure 1-6-6 Removing the feed roller

1-6-5 Removing the MP feed roller

1. Remove the engine board (See page 1-6-9).
2. Remove one screw.
3. Remove the grounding plate.
4. Remove one stop ring .
5. Remove the MP feed clutch.

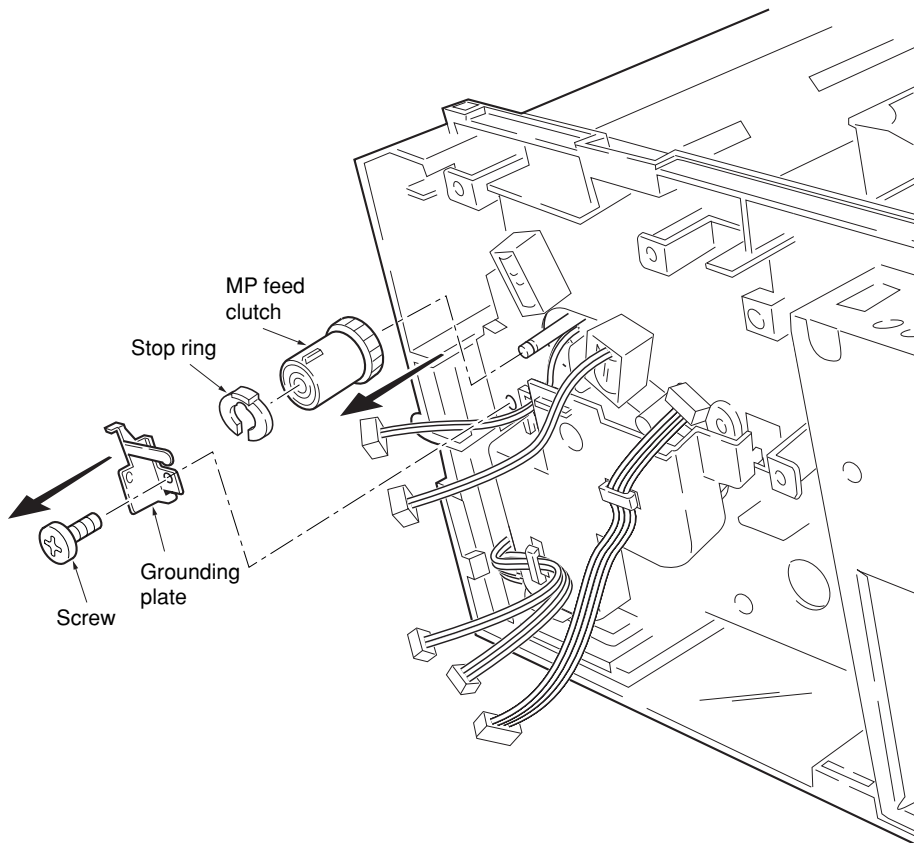

Figure 1-6-7 Removing the MP feed clutch

6. Remove one screw.
7. Remove the toner sensor and spring.
8. Remove two screws.
9. While pressing the latch by using the driver and then remove the MP feed unit.

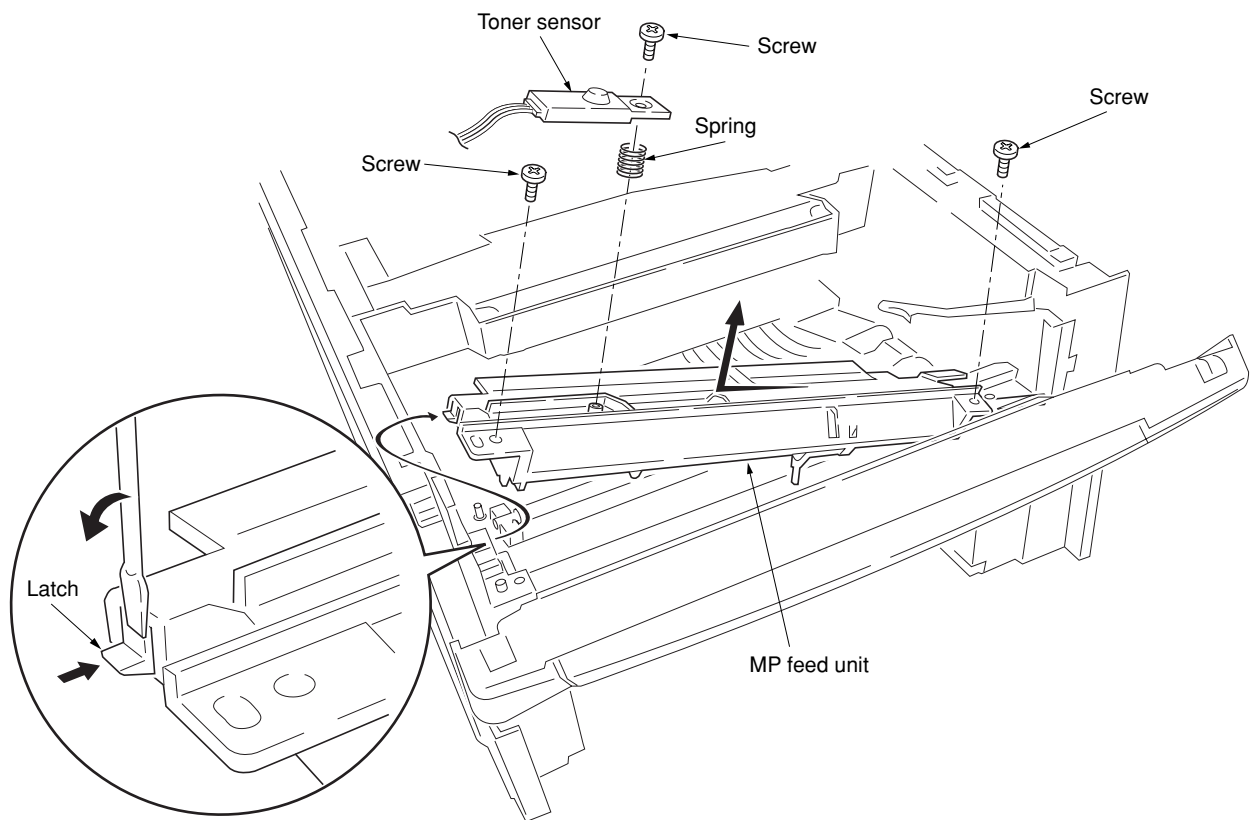

Figure 1-6-8 Removing the MP feed unit

10. Remove the stop ring and then remove the MP feed roller.

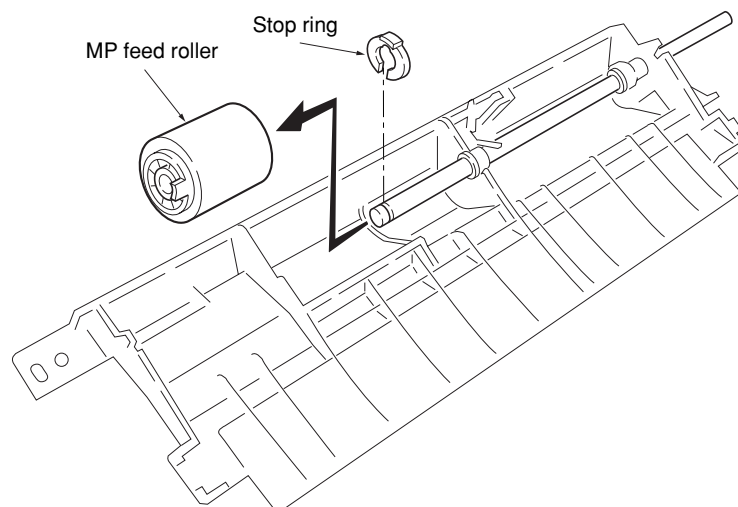

Figure 1-6-9 Removing the MP feed roller

1-6-6 Removing the transfer roller

CAUTION

Do not touch the transfer roller (sponge) surface. Oil and dust (particles of paper, etc.) on the transfer roller can significantly deteriorate the print quality (white spots, etc.).

When refitting the bushes and springs, make sure to refit the black colored bush and spring on the left side. Also, observe the correct direction to which the bush is fit in reference to the paper passing direction.

1. Remove the process unit (See page 1-6-2).
2. Remove the transfer roller from the both bushes.

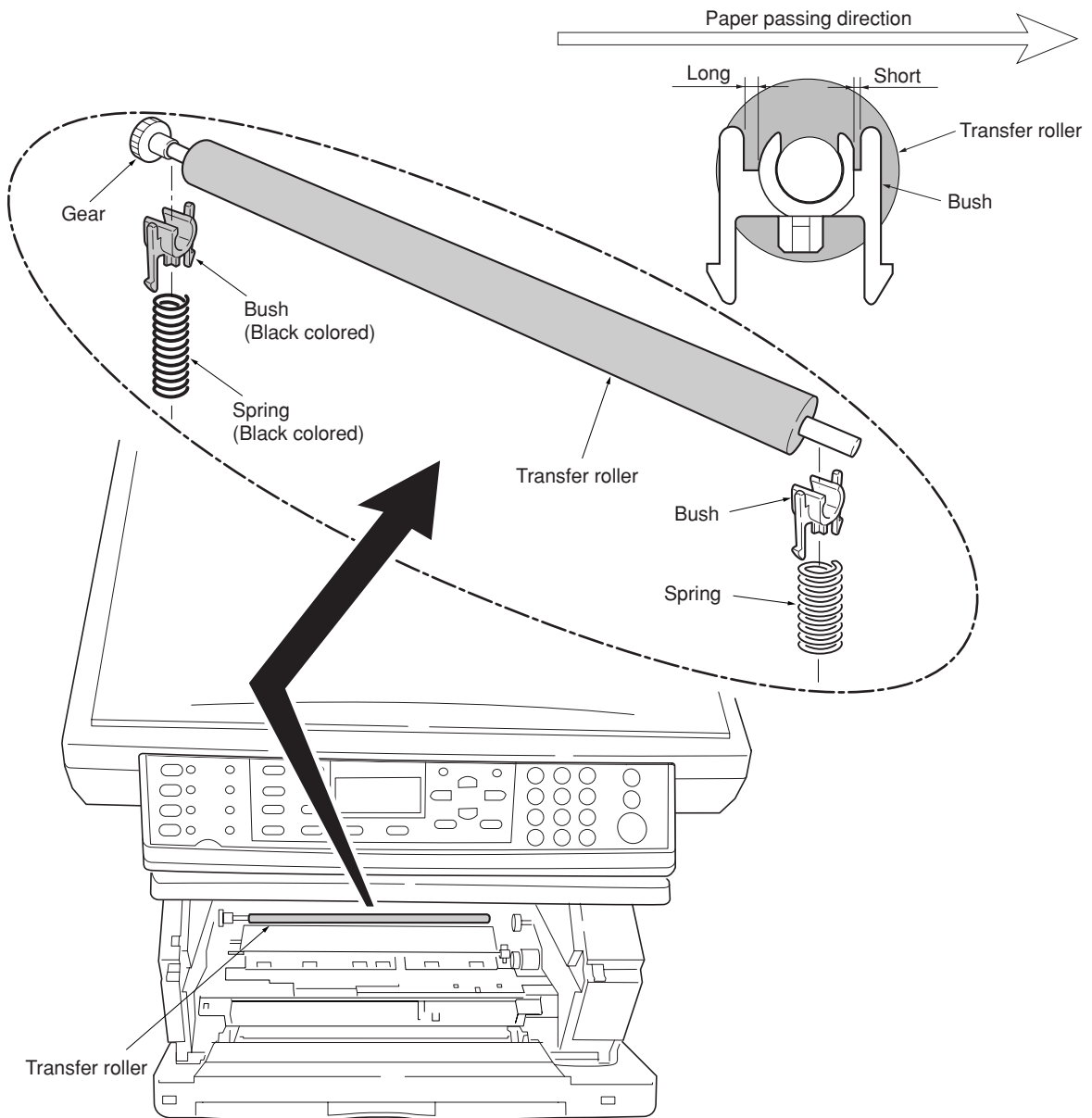

Figure 1-6-10 Removing the transfer roller

1-6-7 Removing the primary circuit boards

(1) Removing the engine board

1. Remove the right cover (See page 1-6-4).
2. Remove all (twelve) connectors from the engine board.
3. Remove three screws.
4. Remove the engine board.

* When replacing the board with a new board, remove the EEPROM from the old board and mount it to the new board.

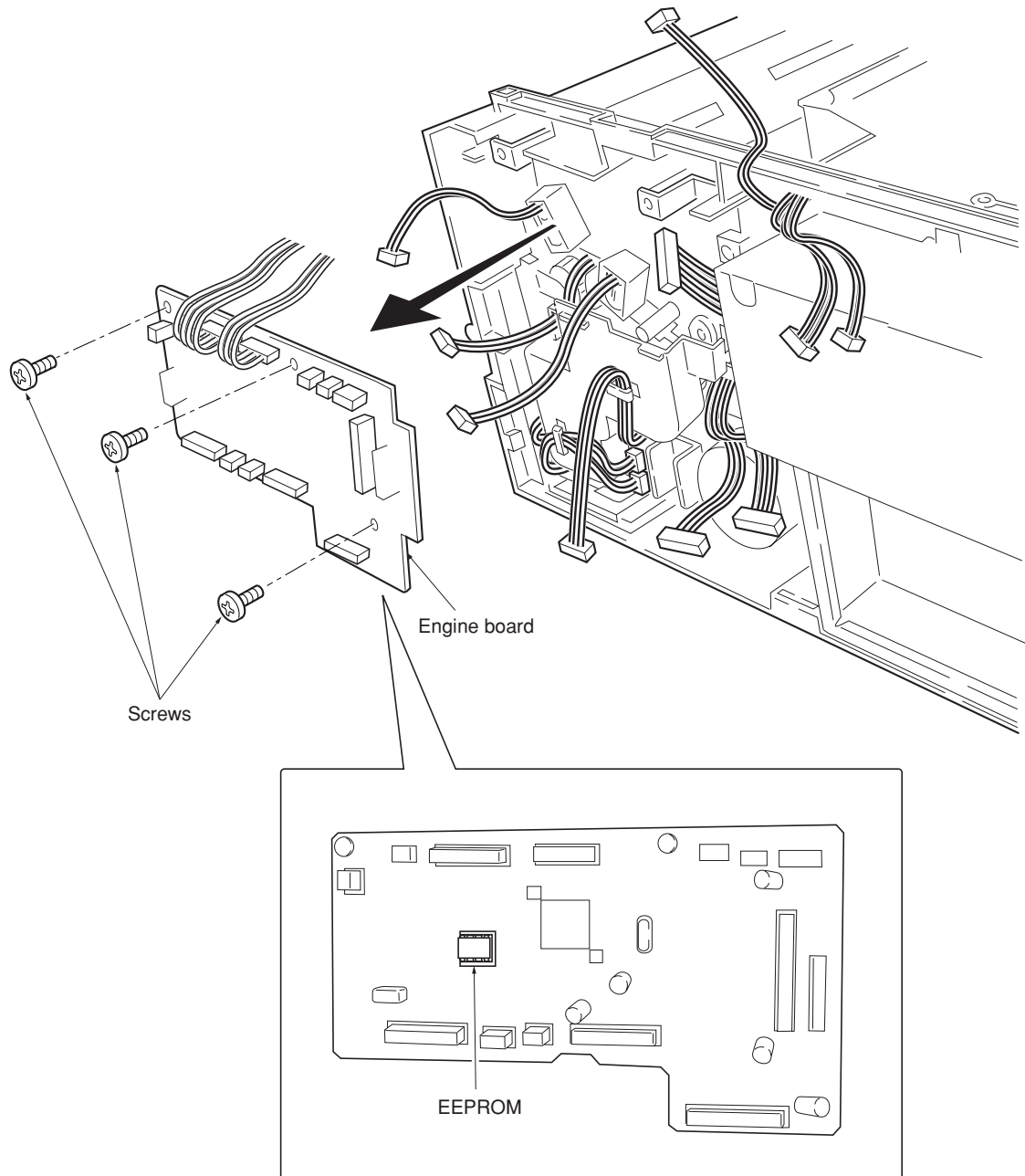

Figure 1-6-11 Removing the engine board

(2) Removing the main board

1. Remove the right cover (See page 1-6-4).
2. Remove the one connector.
3. Remove the one screw and then remove the speaker.

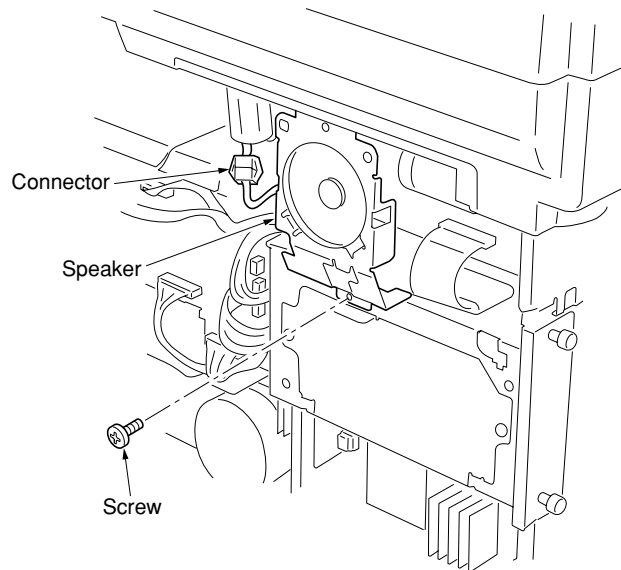

Figure 1-6-12a Removing the speaker

4. Remove the three connectors.
5. Remove the one flexible flat cable.
6. Remove the seven screws and then remove the main controller shield (with main board).

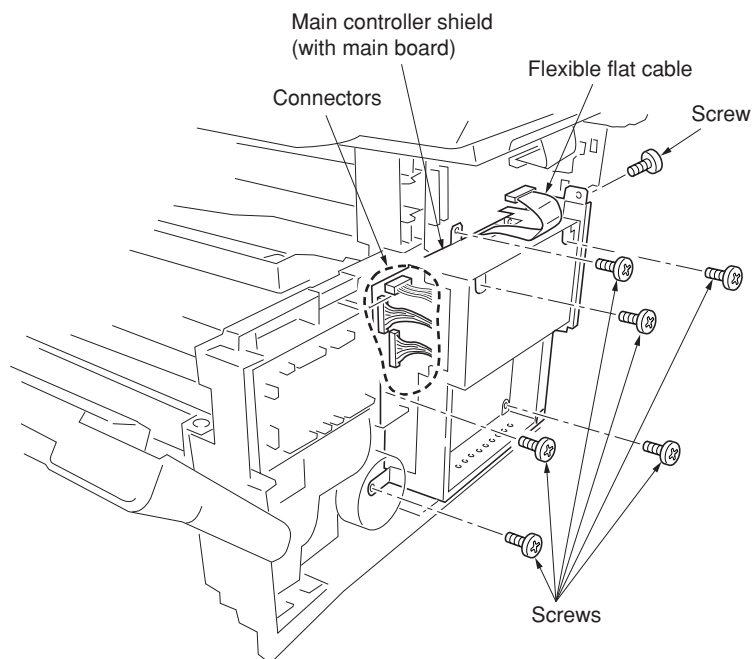

Figure 1-6-12b Removing the main controller shield (with main board)

7. Remove two screws at the back of the main board.

* When replacing the board with a new board, remove the EEPROM from the old board and mount it to the new board.

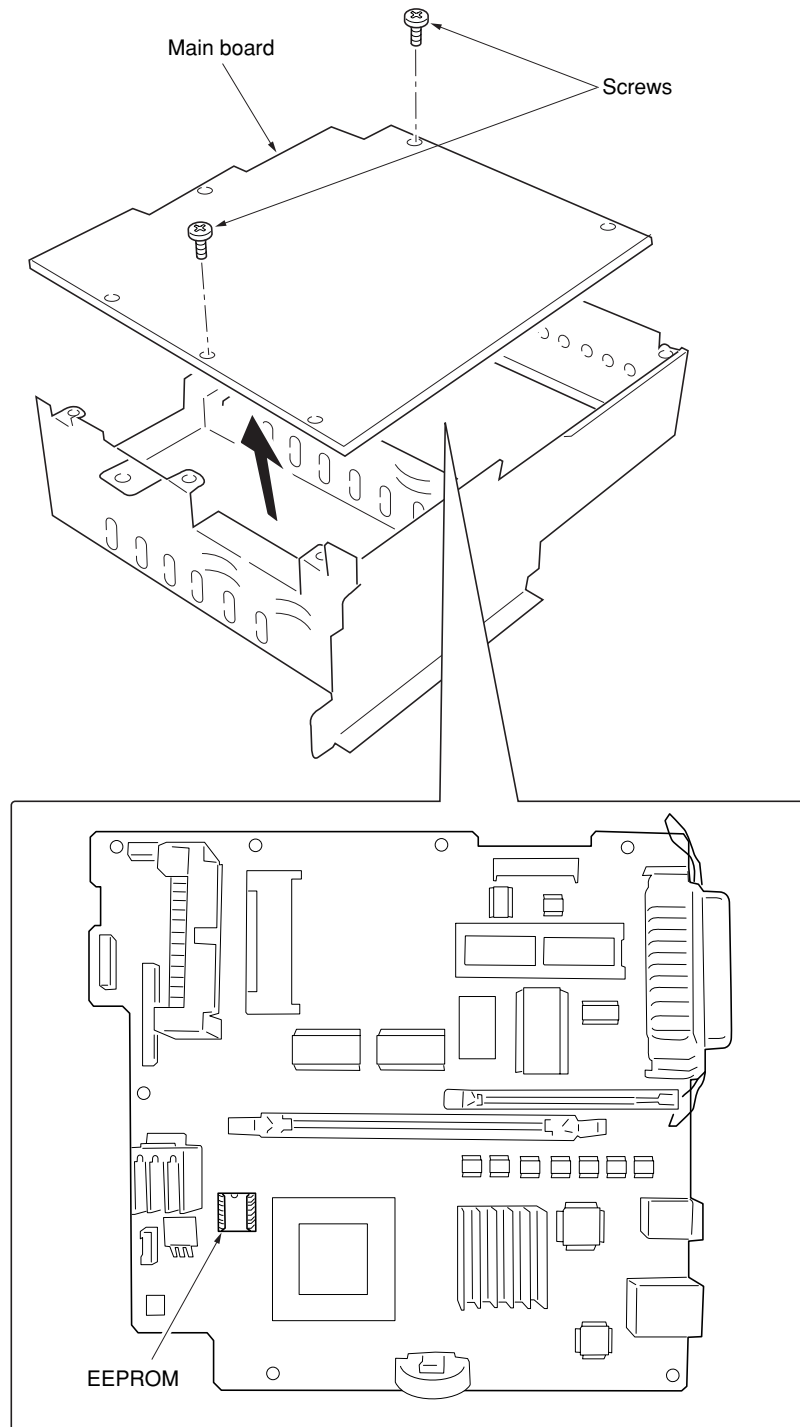
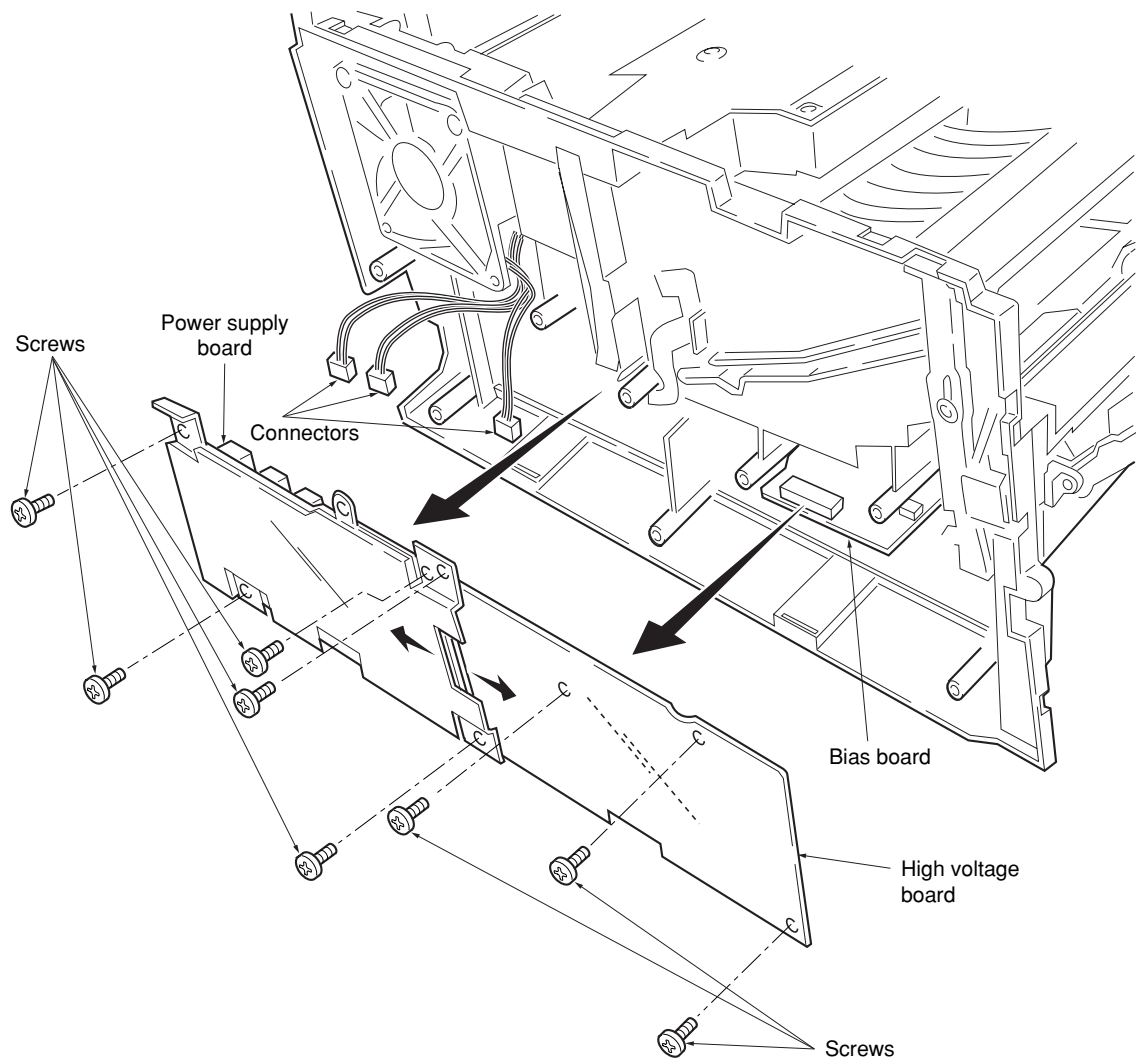

Figure 1-6-13 Removing the main board

(3) Removing the power supply board and high voltage board

1. Remove the process unit (See page 1-6-2).
2. Remove the left cover (See page 1-6-4).
3. Remove three connectors from the power supply board.
4. Remove eight screws.
5. Remove the power supply board and high voltage board. (Note: The high voltage board is directly connected to the bias board.)
6. Separate the high voltage board from the power supply board.

**Figure 1-6-14 Removing the power supply board and high voltage board**

(4) Removing the bias board

1. Remove the cassette and process unit (See page 1-6-2).
2. Remove the left cover (See page 1-6-4).
3. Remove the power supply board and high voltage board (See the previous page).
4. Stand the machine with the front side up.
5. Remove one connector from the bias board.
6. Remove five screws.
7. Remove the bottom cover.
8. Remove the two connectors from the bias board.
9. Remove the bias board.

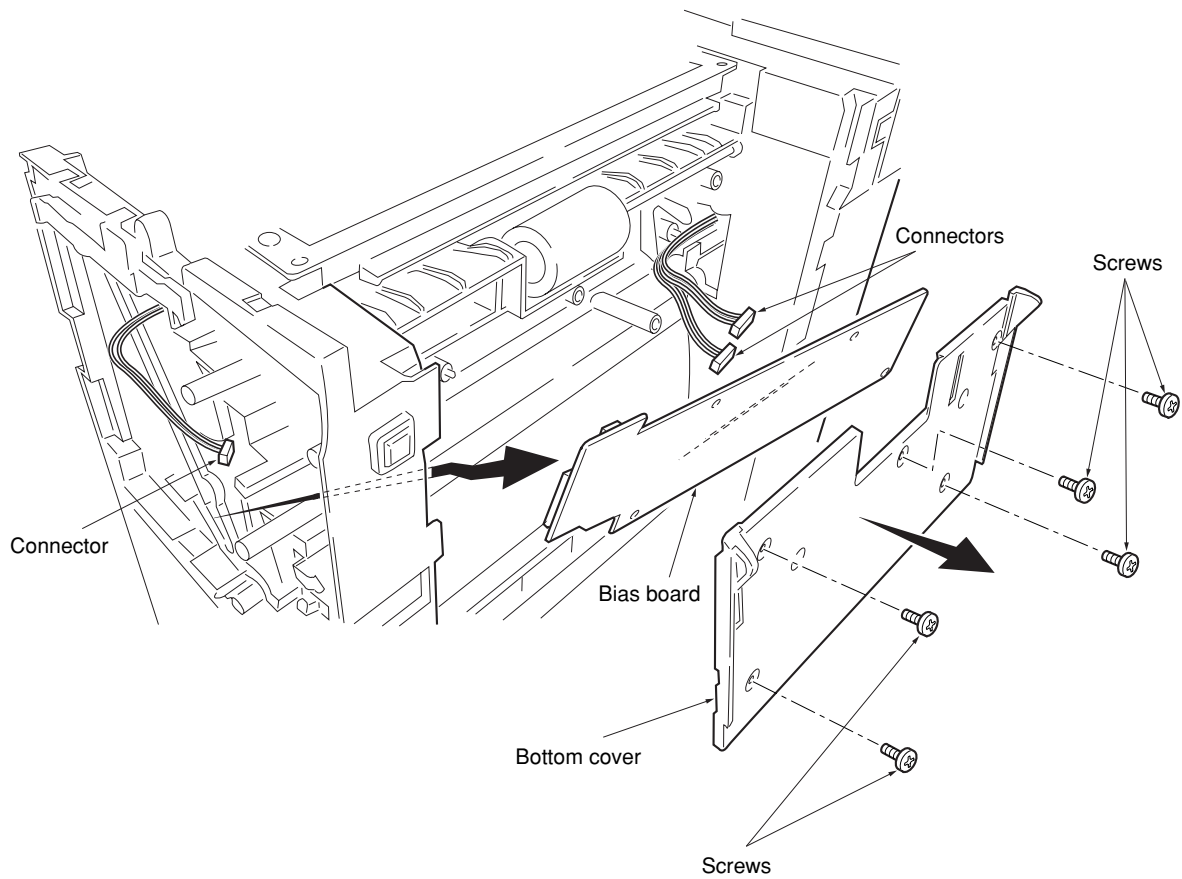

Figure 1-6-15 Removing the bias board

1-6-8 Removing the main motor and drive unit

1. Remove the cassette and process unit (See page 1-6-2).
2. Remove the right cover (See page 1-6-4).
3. Remove three connectors from the main motor.
4. Remove four screws.
5. Remove main motor.

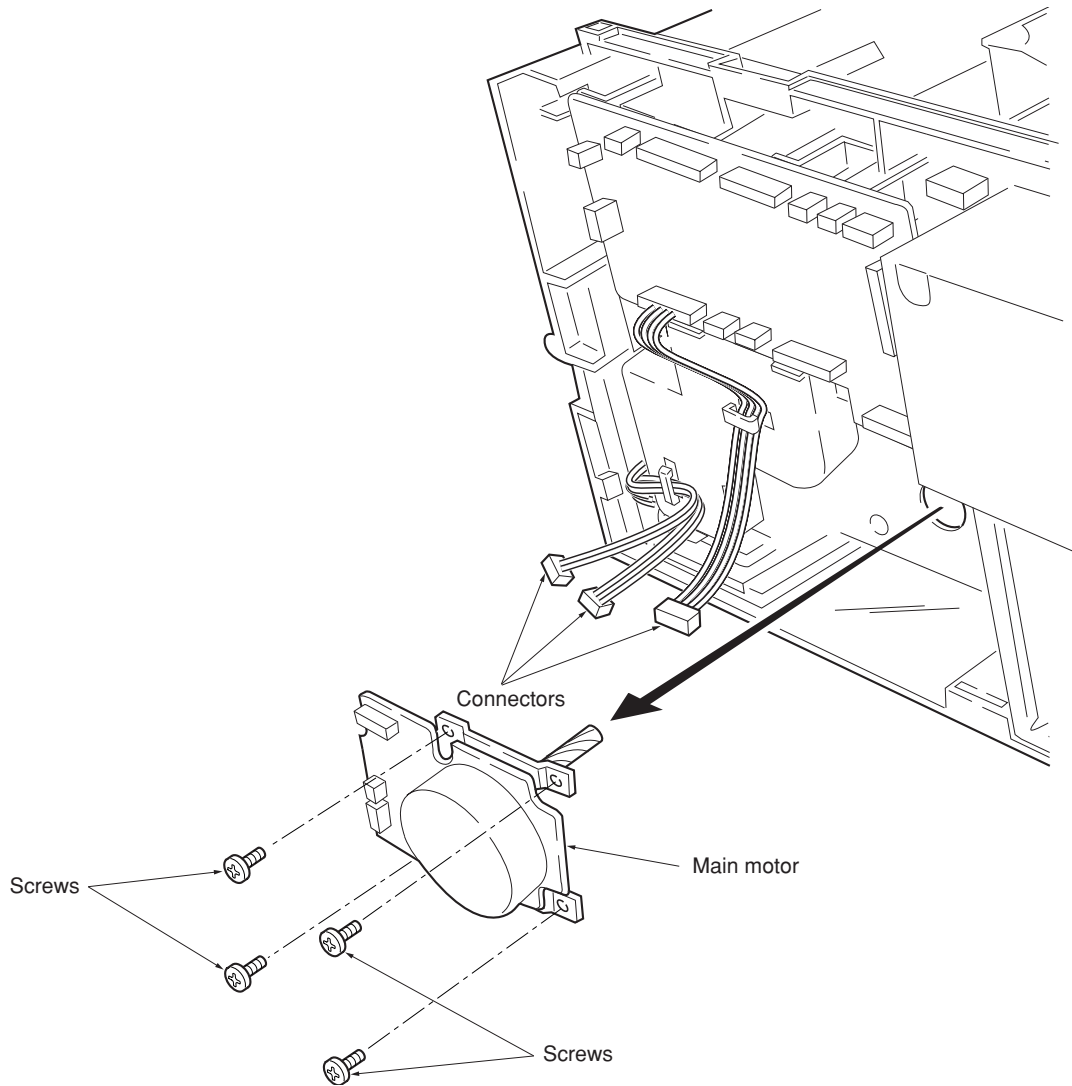

Figure 1-6-16 Removing the main motor

6. Remove the engine board (See page 1-6-9).
7. Remove wires from wire saddles on the cord cover.
8. Remove one screw.
9. Remove the cord cover.

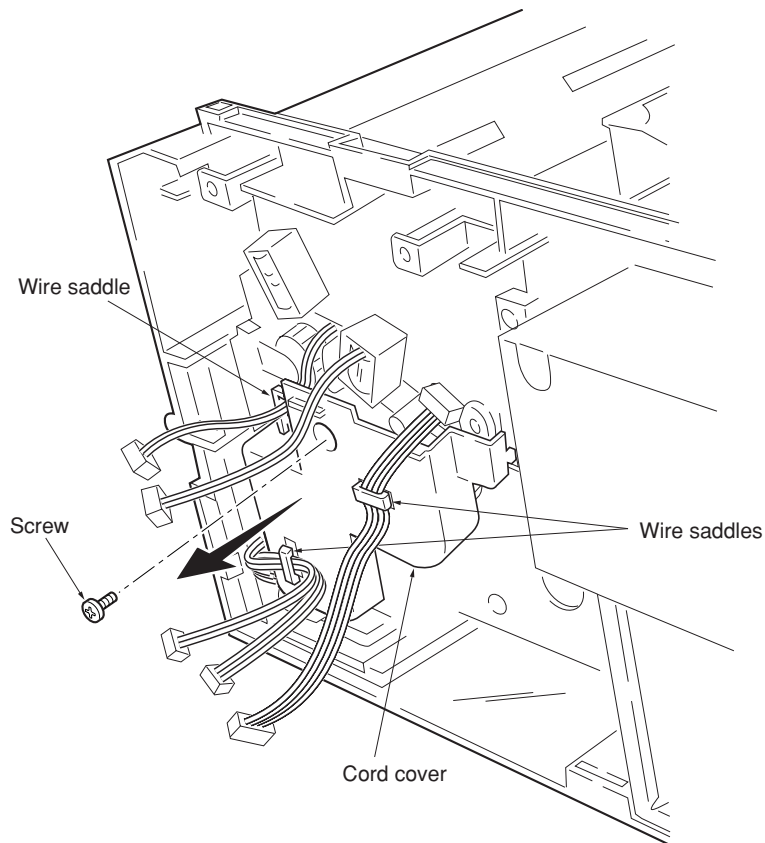

Figure 1-6-17 Removing the cord cover

10. Remove the main board (See page 1-6-10).
11. Remove one screw and then remove the grounding plate.
12. Remove one screw and then remove the feed clutch.
13. Remove three stop rings.
14. Remove MP feed clutch (gear), feed clutch (gear), and registration clutch (gear).

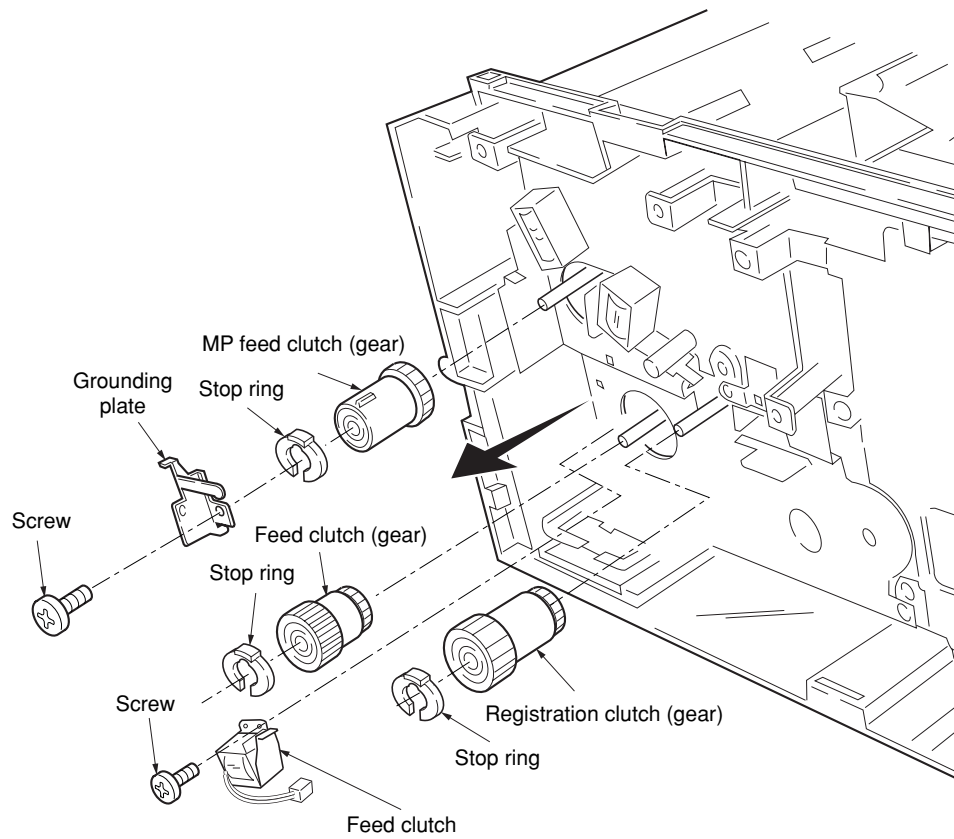

Figure 1-6-18 Removing the clutches

- 15. Remove the four screws.
- 16. Remove the drive unit.

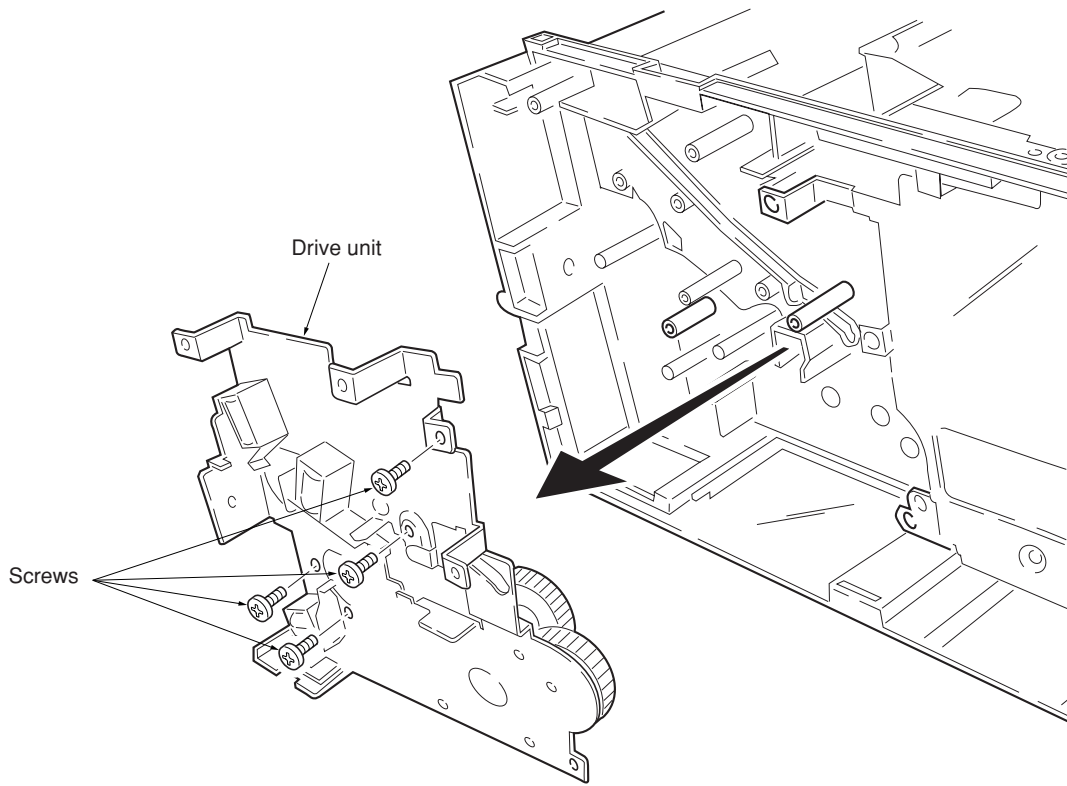

Figure 1-6-19 Removing the drive unit

1-6-9 Removing and splitting the fuser unit

WARNING

- The fuser unit is hot after the machine was running. Wait until it cools down.

CAUTION

- When refitting the fuser unit, make sure the fuser unit gear and the machine's drive gear are properly meshed with each other. For this, rotate the main motor several turns before fixing screws.

1. Remove the rear cover (See page 1-6-3).
2. Remove the right and left cover (See page 1-6-4).
3. Remove the two connectors.
4. Remove two screws.
5. Remove the fuser unit.

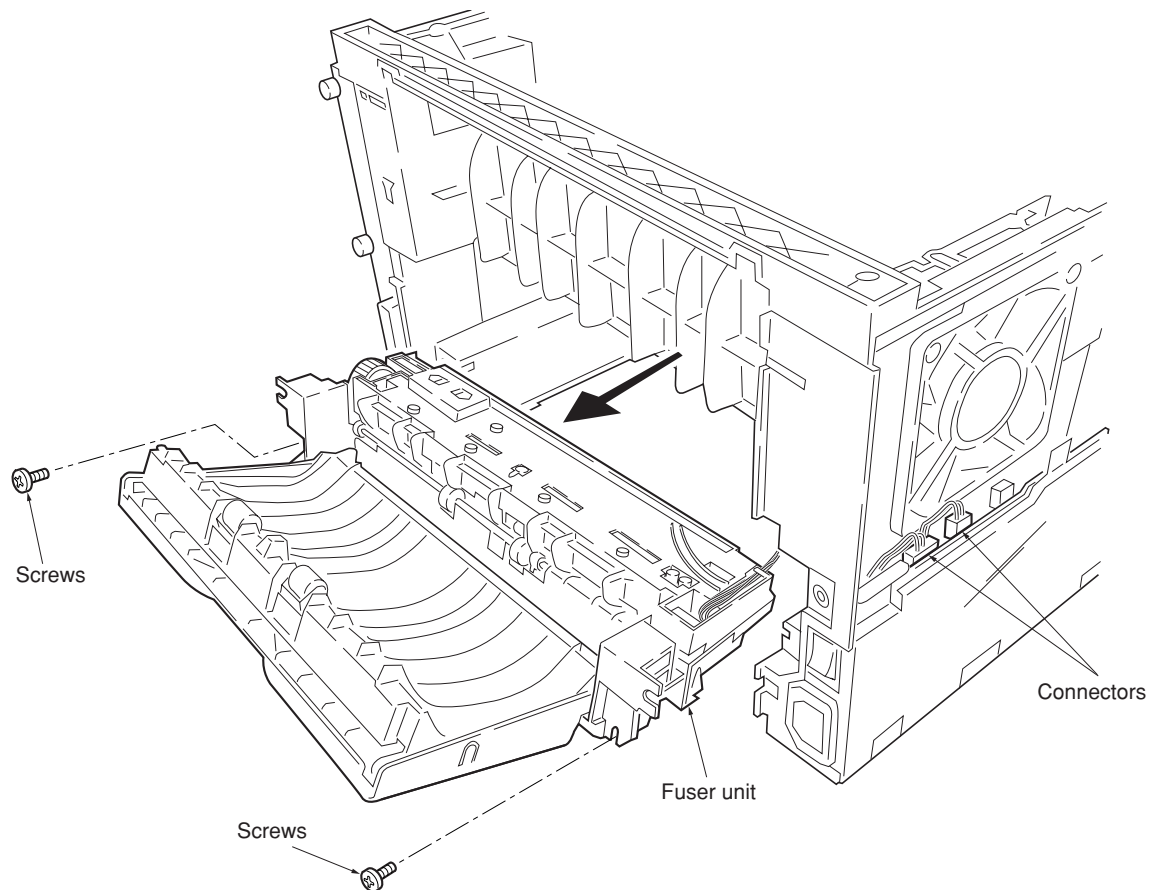

Figure 1-6-20 Removing the fuser unit

- 6. Remove two screws.
- 7. Open and split the fuser unit.

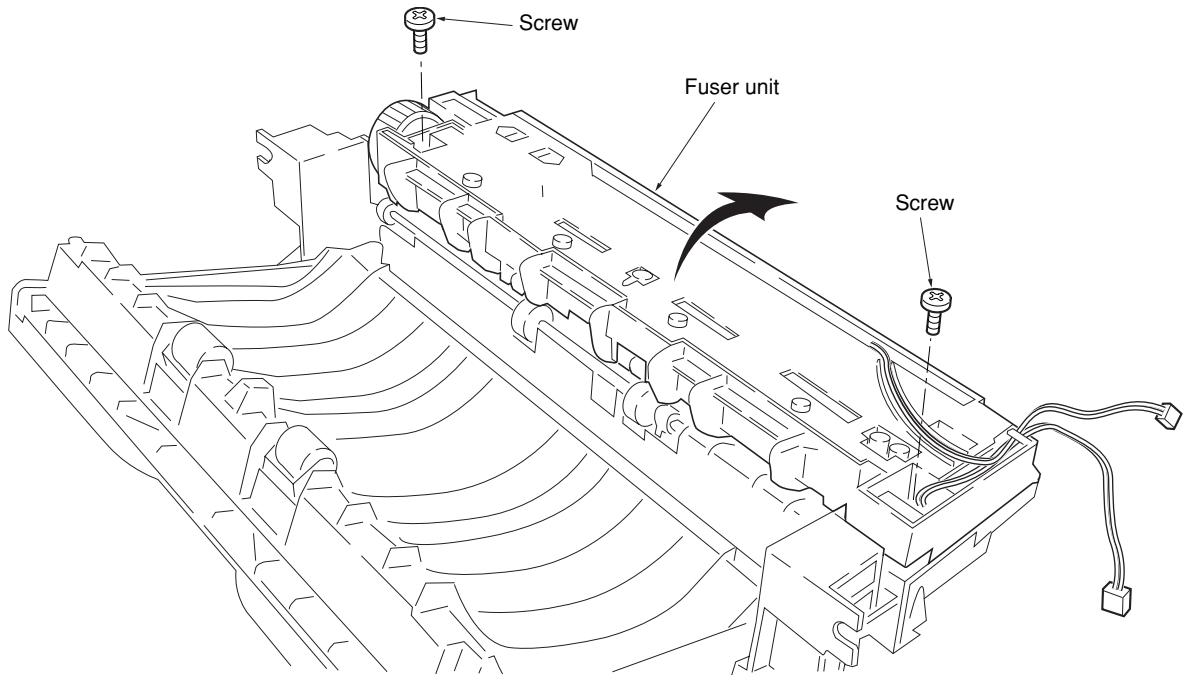

Figure 1-6-21 Splitting the fuser unit

(1) Removing the separation claws

WARNING

The separation claws are extremely hot immediately after the copier was running. Allow substantial period of time until it cools down.

1. Remove and split the fuser unit (See page 1-6-18).
2. Loosen the stopper screws.
3. Hold the separation claw upright, and remove the separation claw and separation claw springs.

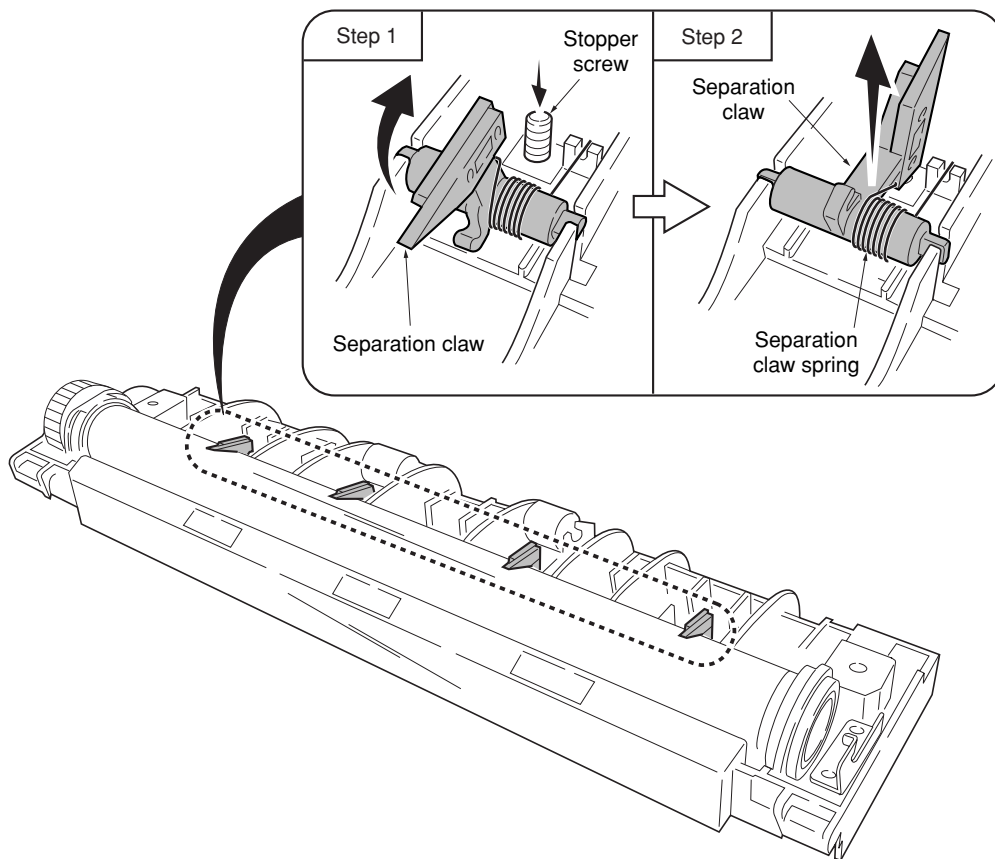

Figure 1-6-22 Removing the separation claws

(2) Removing the heater lamp

WARNING

- The heater lamp is extremely hot immediately after the machine was running.
- Allow substantial period of time until it cools down. Also, the heater lamp is fragile: Handle it with great care.

CAUTION

- The heater lamps are fragile. Use extreme care when handling not to drop or break.
- Do not directly touch on the heater lamp. Finger prints on the heater lamp's outer surface can prevent proper fusing of toner on paper.
- When refitting the heater lamp, direct the short distance side from the projection in the middle of the lamp facing the machine's left side.

1. Remove and split the fuser unit (See page 1-6-18).
2. Remove all (four) separation claws (See previous page).
3. Remove one screw, release the tension of the lamp A holder.
4. Remove the heater lamp from the lamp B holder.
5. Remove the heater lamp from the heat roller.

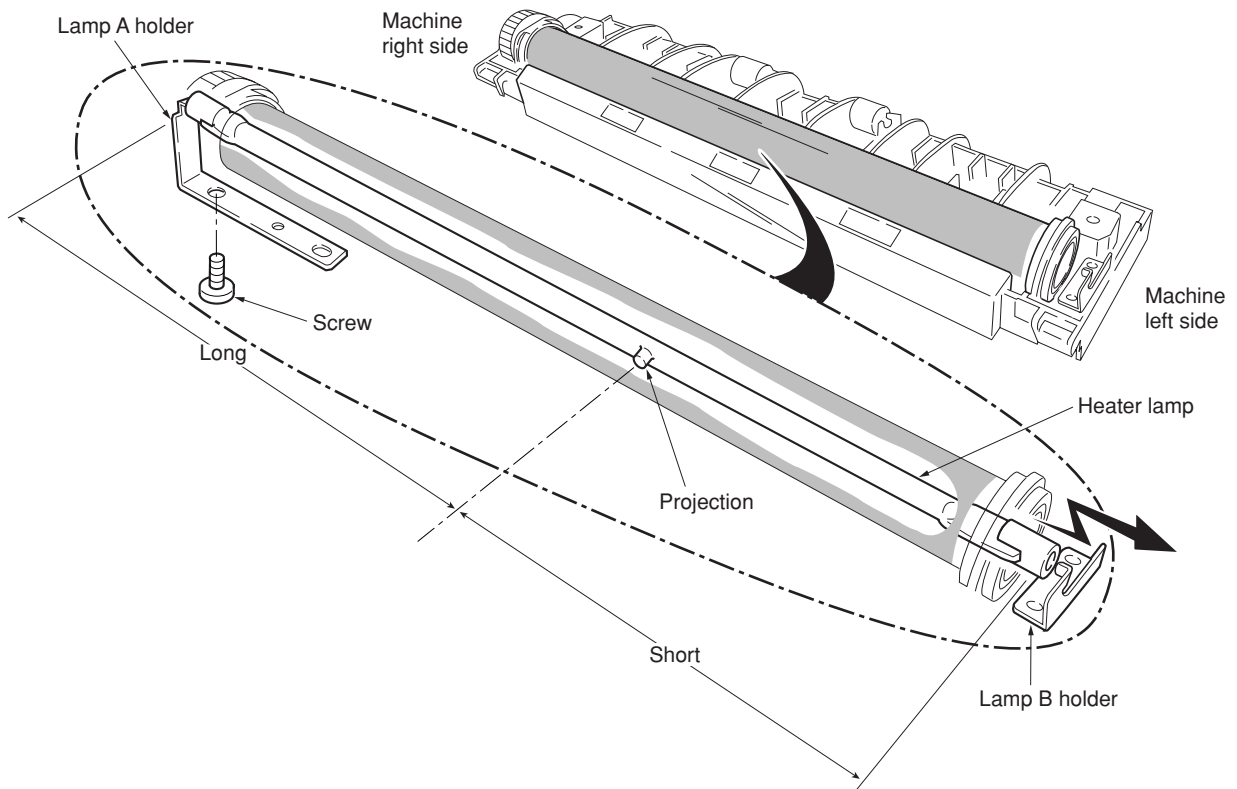

Figure 1-6-23 Removing the heater lamp

(3) Removing the heat roller

WARNING

• The heat roller is extremely hot immediately after the machine was running. Allow substantial period of time until it cools down.

1. Remove and split the fuser unit (See page 1-6-18).
2. Remove the heater lamp (See previous page).
3. Press the lamp A holder away from the heat roller. Pull up both heat R bush and heat L bush at the same time.

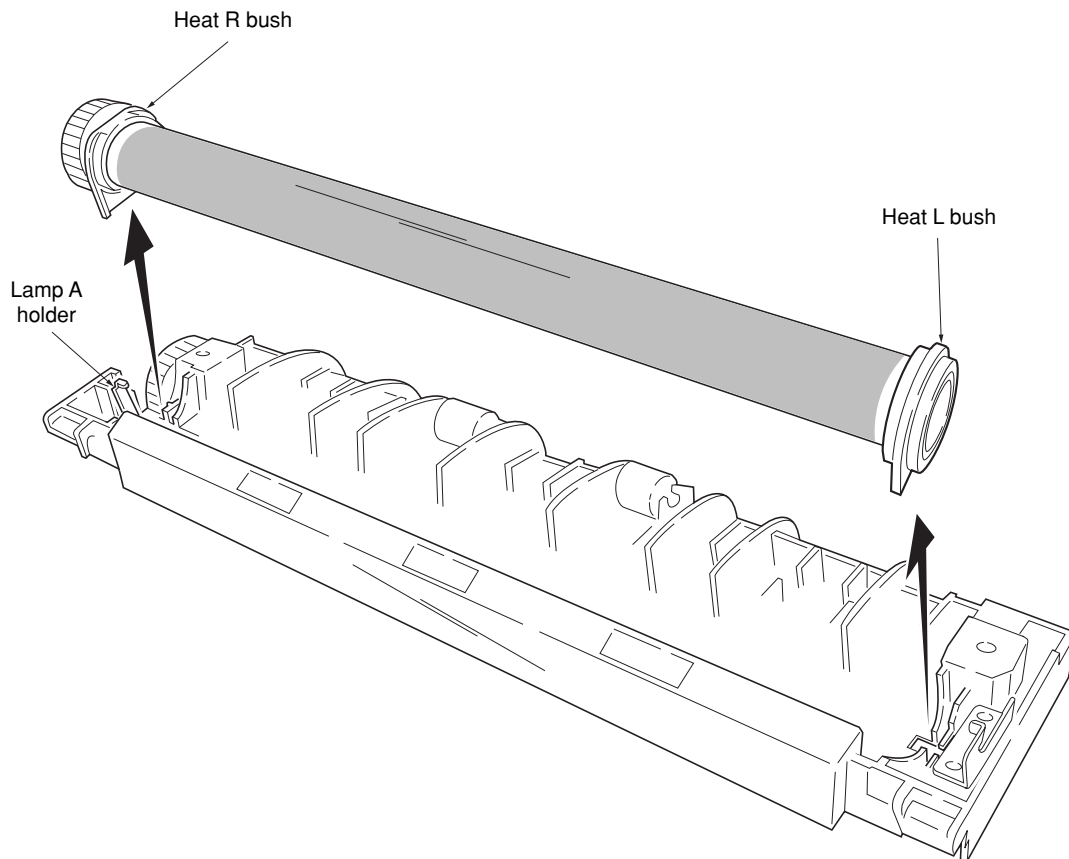

Figure 1-6-24 Removing the heat R bush and heat L bush

4. Remove the heat gear Z33, heat R bush, and heat L bush from the heat roller.

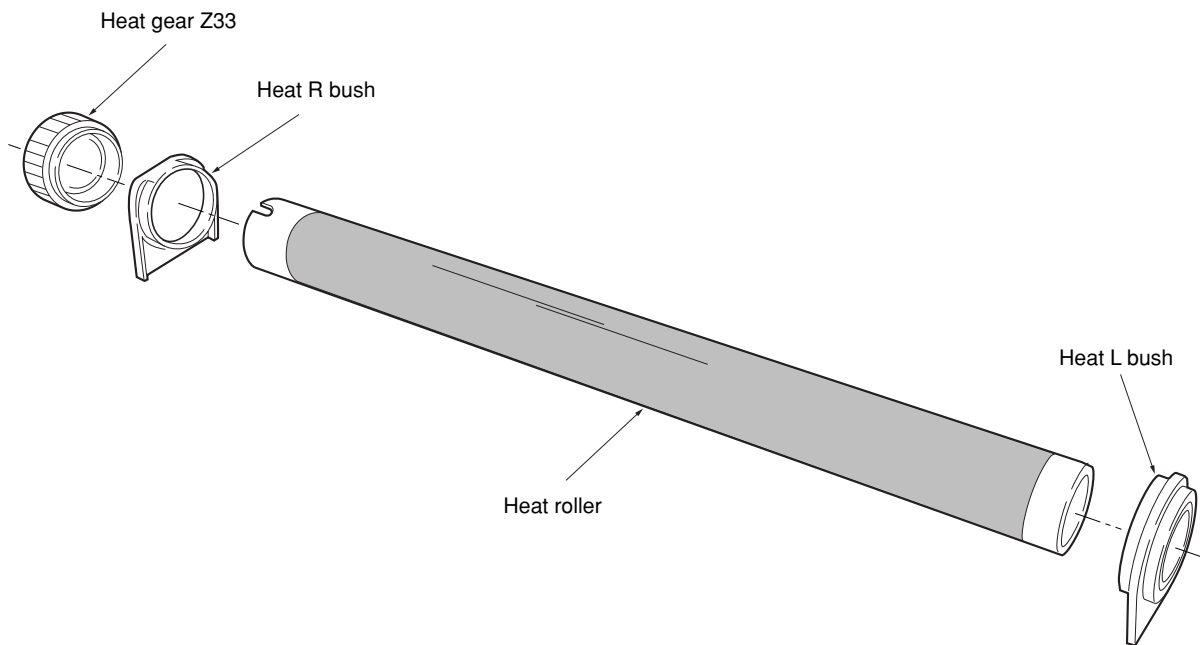

Figure 1-6-25 Removing the heat roller

(4) Removing the thermistor

1. Remove and split the fuser unit (See page 1-6-18).
2. Remove the heater lamp (See page 1-6-21).
3. Remove the heat roller (See page 1-6-22).
4. Remove one screw.
5. Remove the thermistor.

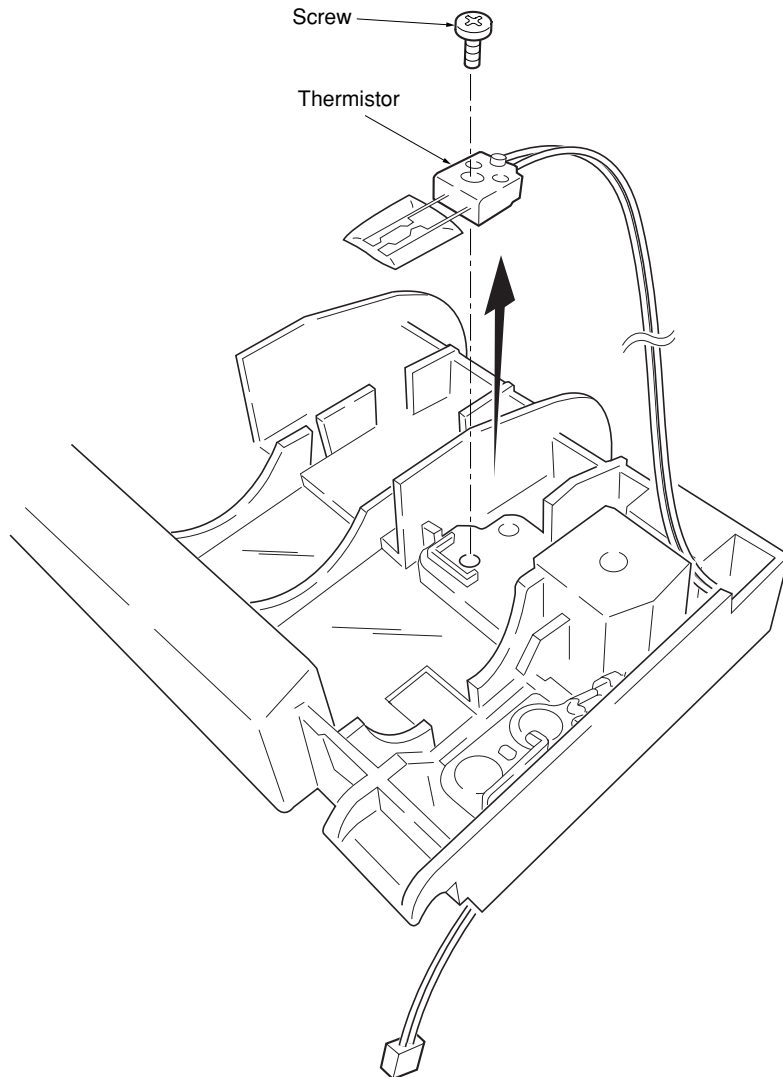
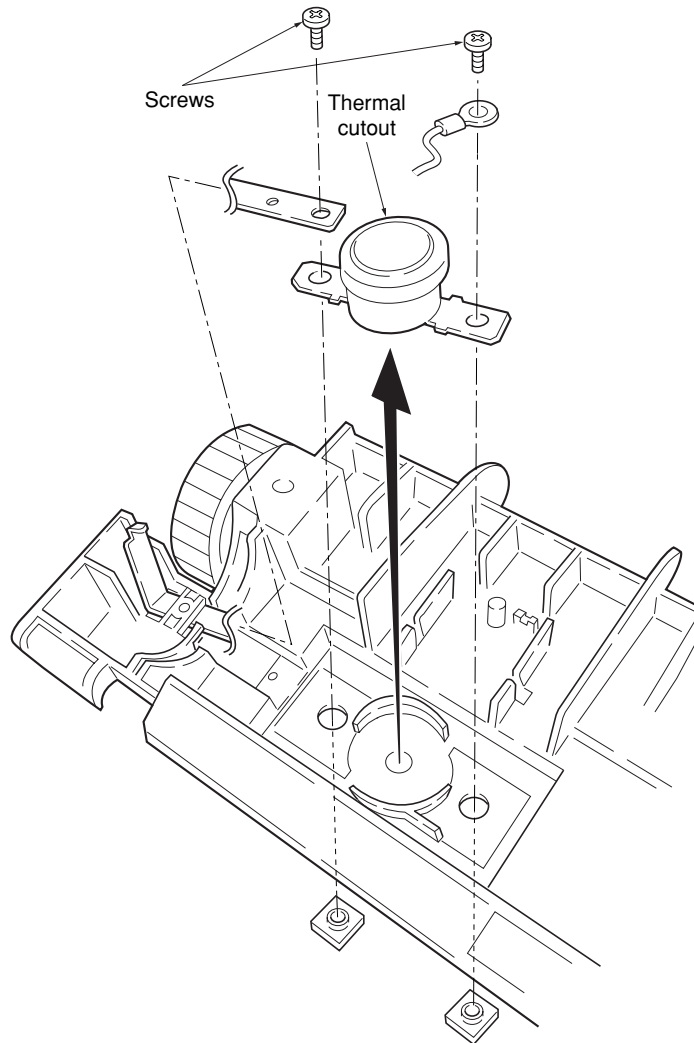

Figure 1-6-26 Removing the thermistor

(5) Removing the thermal cutout**CAUTION**

- Do not bend the terminals of the thermal cutout.

1. Remove and split the fuser unit (See page 1-6-18).
2. Remove the heater lamp (See page 1-6-21).
3. Remove the heat roller (See page 1-6-22).
4. Remove the two screws.
5. Remove the thermal cutout.

**Figure 1-6-27 Removing the thermal cutout**

(6) Removing the press roller

WARNING

- The press roller is extremely hot immediately after the machine was running. Allow substantial period of time until it cools down.

1. Remove and split the fuser unit (See page 1-6-18).
2. Remove the press roller from the fuser unit.

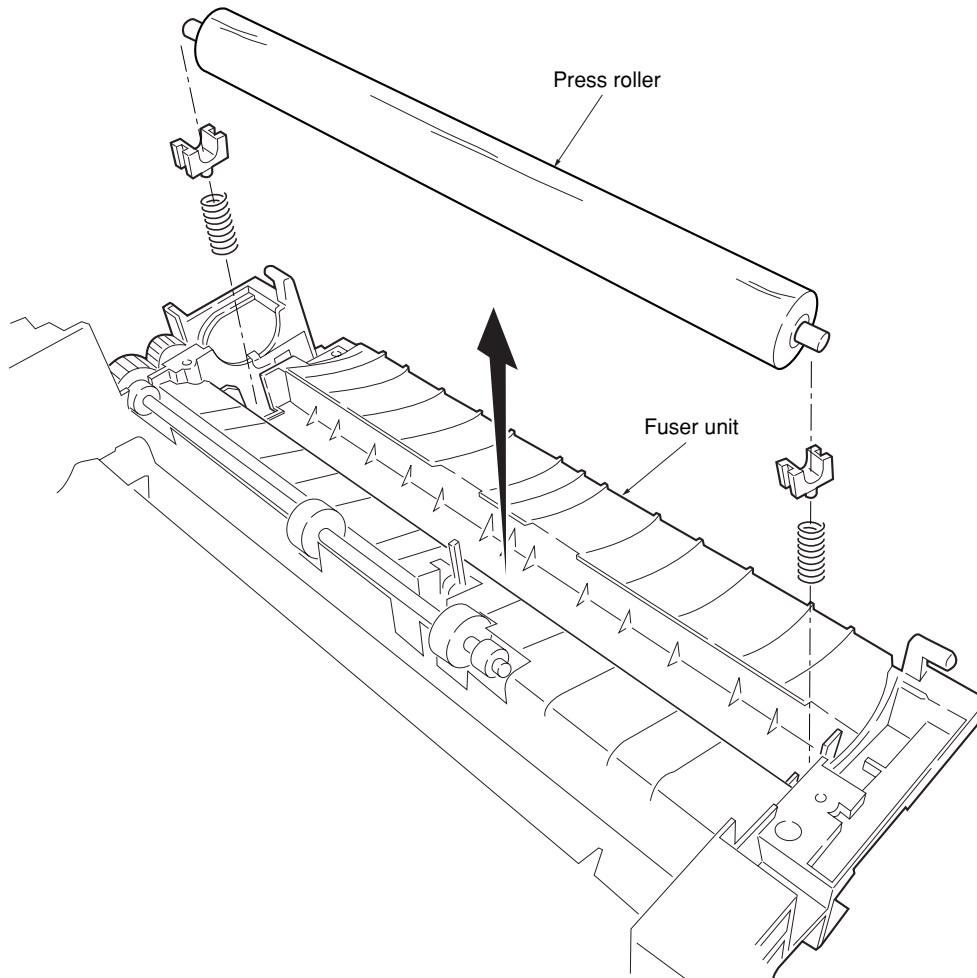

Figure 1-6-28 Removing the press roller

1-6-10 Removing the scanner unit

1. Remove the right and left cover (See page 1-6-4).
2. Remove the speaker (See page 1-6-10).
3. Remove the five connectors and two flexible flat cables from the scanner board.
4. Remove the five screws and then remove the scanner board.

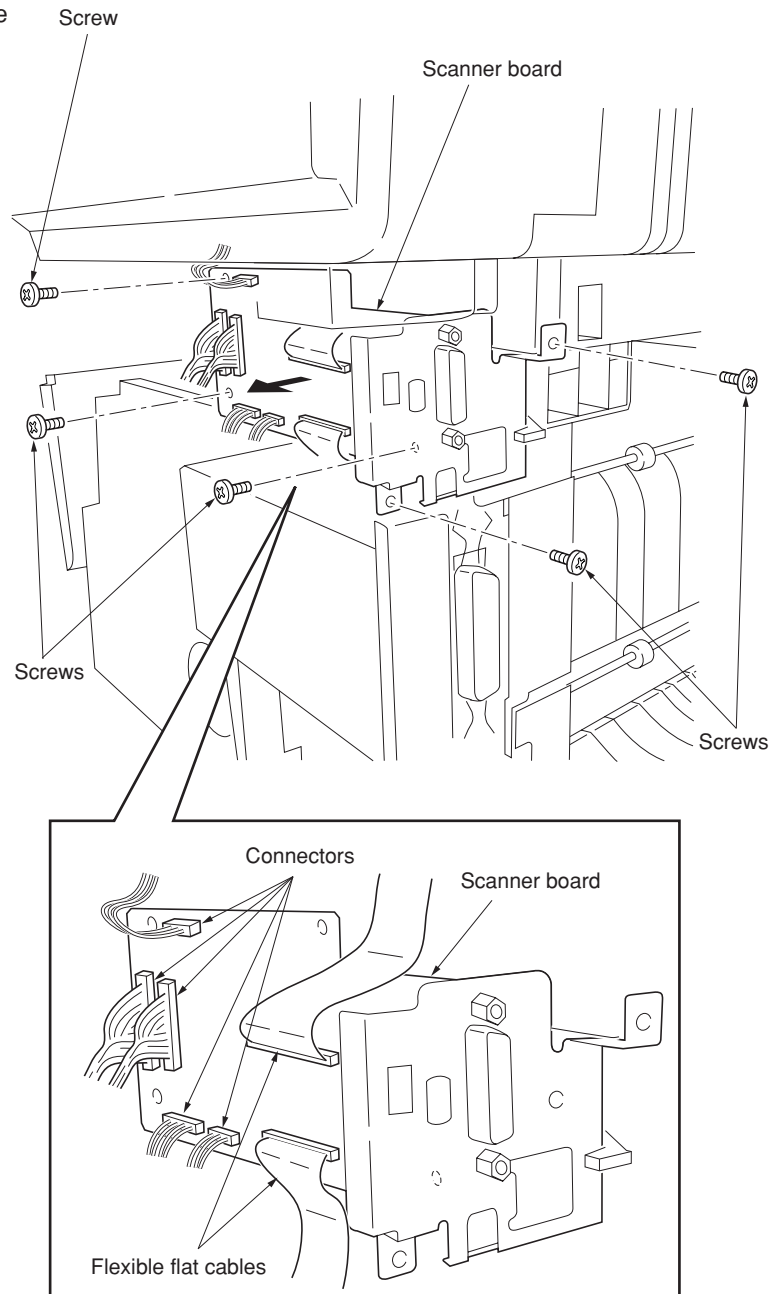

Figure 1-6-29 Removing the scanner PWB

2DD

4. Remove the two screws.
5. Slide the scanner unit and then remove the scanner unit.

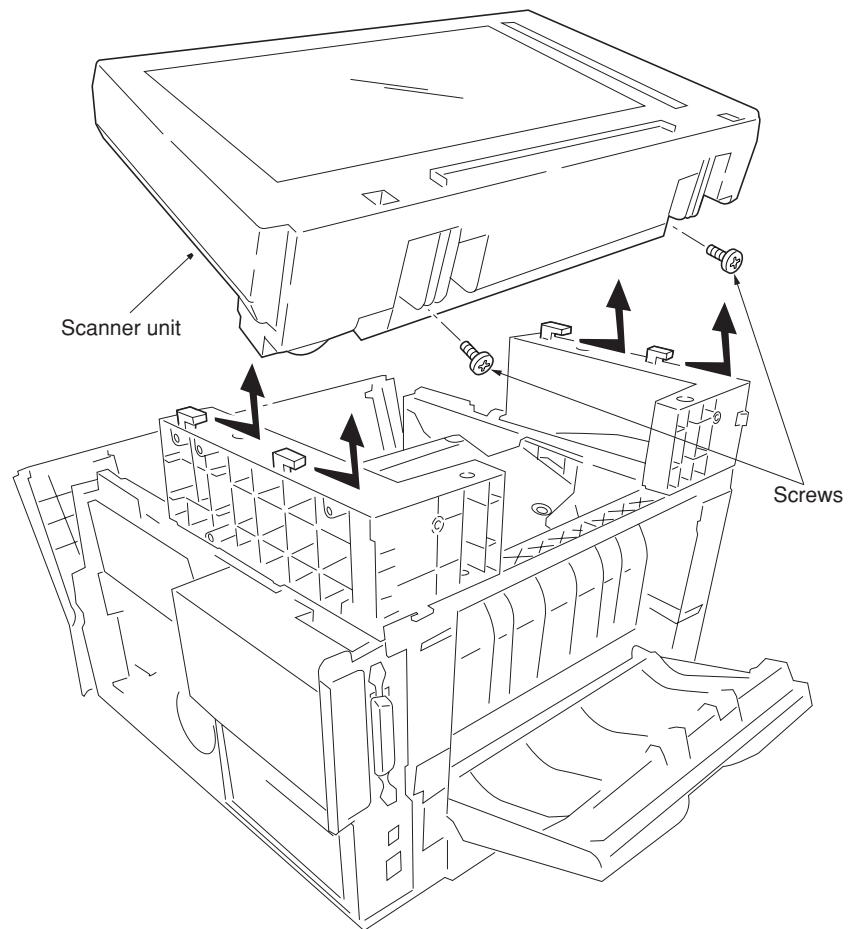

Figure 1-6-30 Removing the scanner unit

1-6-11 Removing the laser scanner unit and the eraser lamp

1. Remove the scanner unit (See page 1-6-27).
2. Remove two screws and then remove grounding plate.
3. Remove each two screws and then remove the right and left scanner stays.

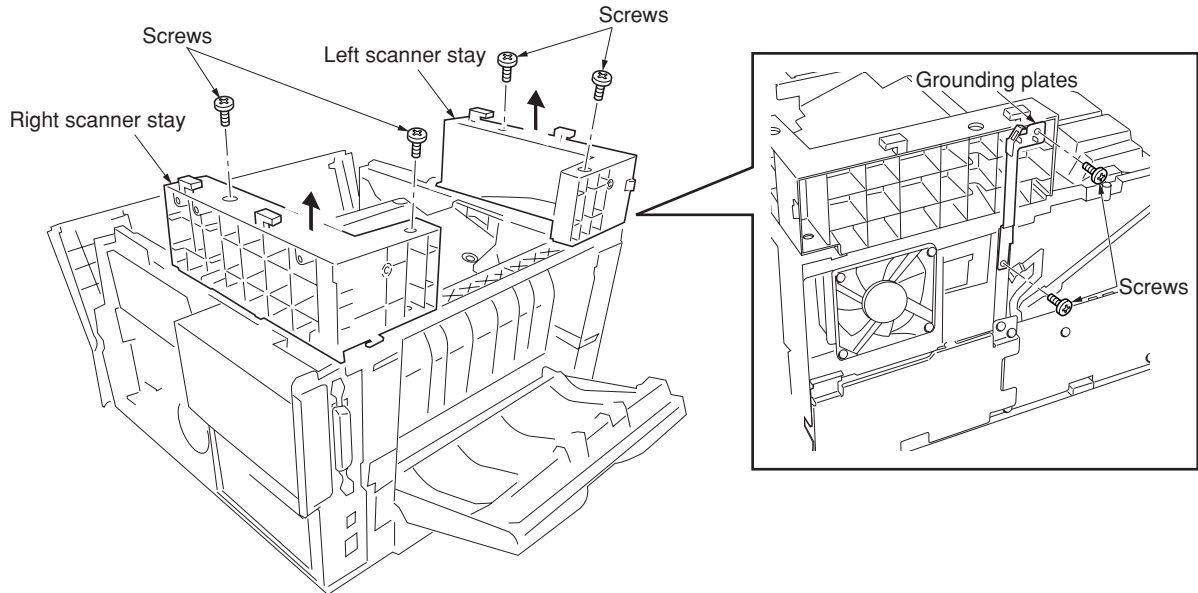

Figure 1-6-31 Removing the right and left stays

4. Remove four connectors.
5. Remove six screws and then remove the LSU shield.

* When refitting the LSU shield, tighten a screw in order of ④ from ①.

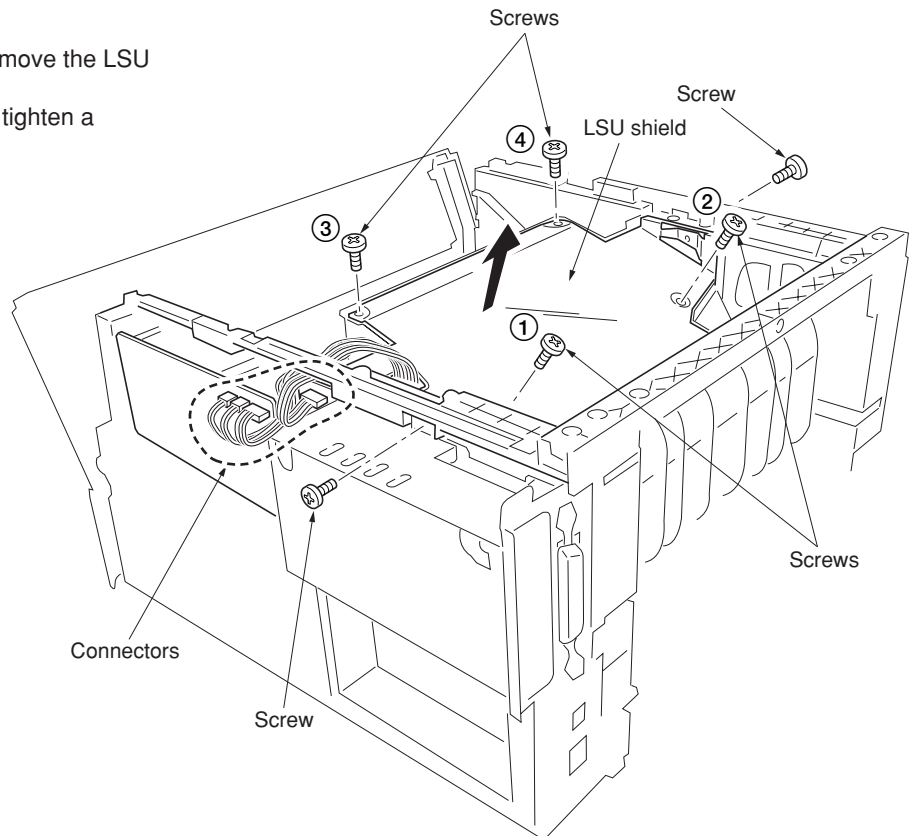

Figure 1-6-32 Removing the LSU shield

2DD

6. Remove three screws.
 7. Remove two connectors from the laser scanner unit.
 8. Remove the laser scanner unit.
- * When refitting the laser scanner unit, tighten a screw in order of ③ from ①.

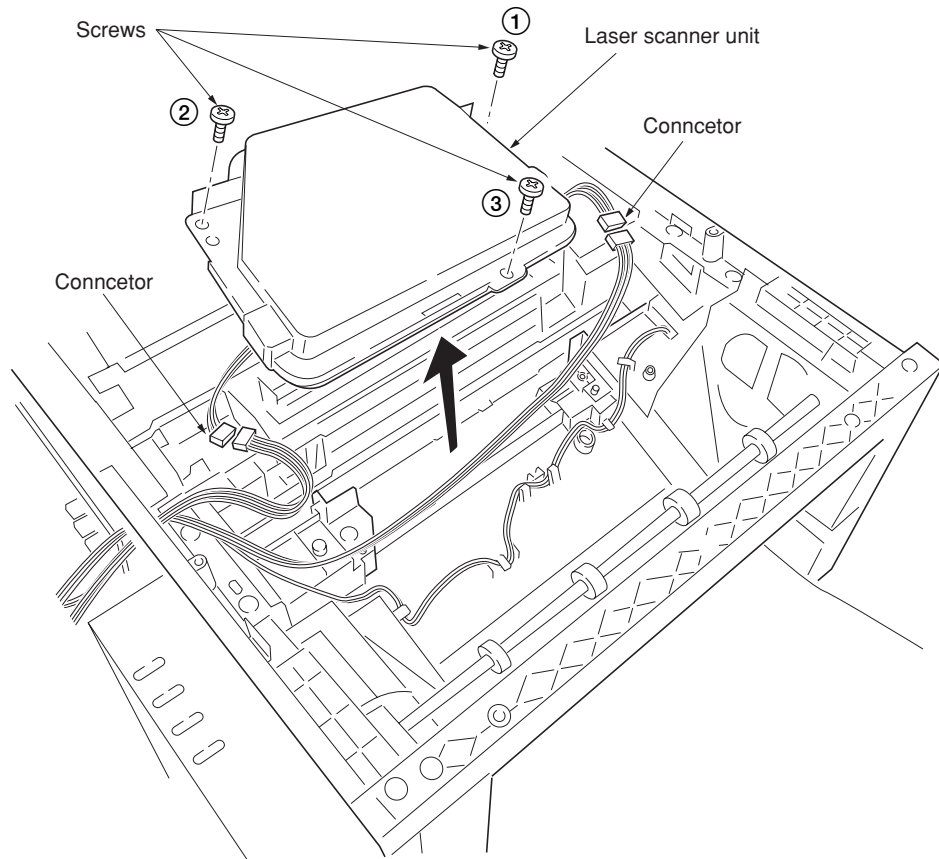
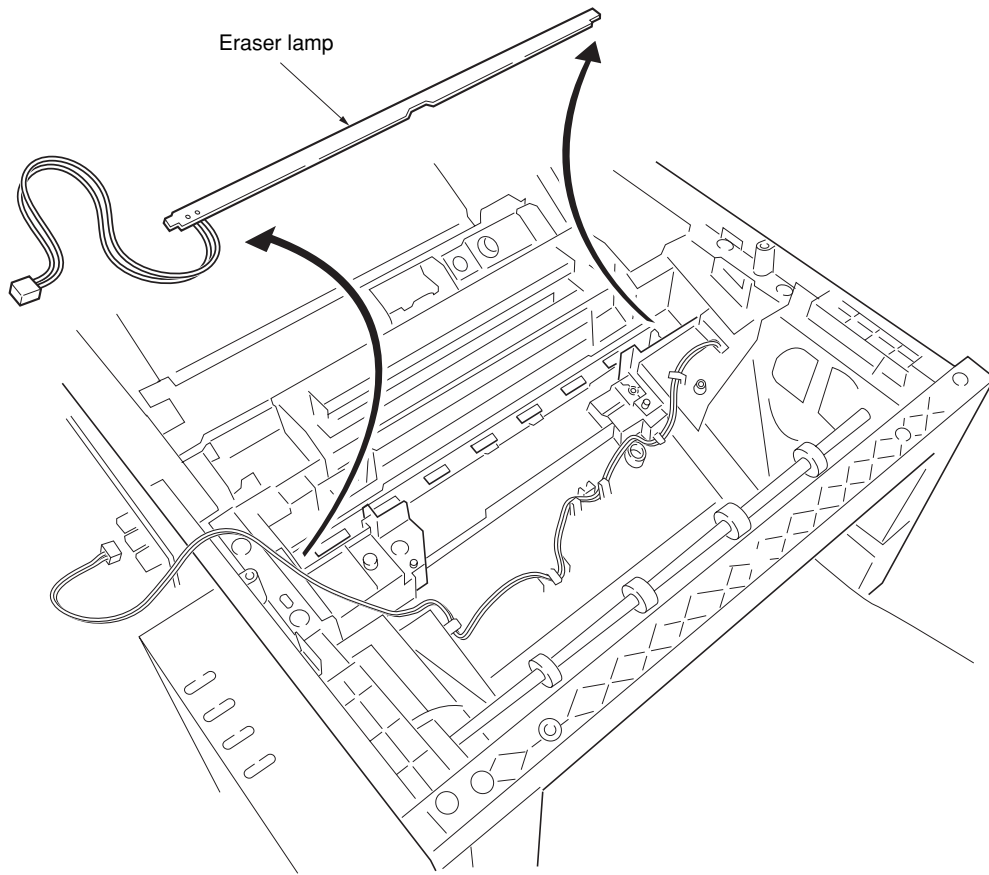

Figure 1-6-33 Removing the laser scanner unit

9. Remove the eraser lamp.



5-2-34 Removing the eraser lamp

1-6-12 Removing the ISU unit

1. Unhook the two hooks by using screw driver through the holes and then remove the operation unit.

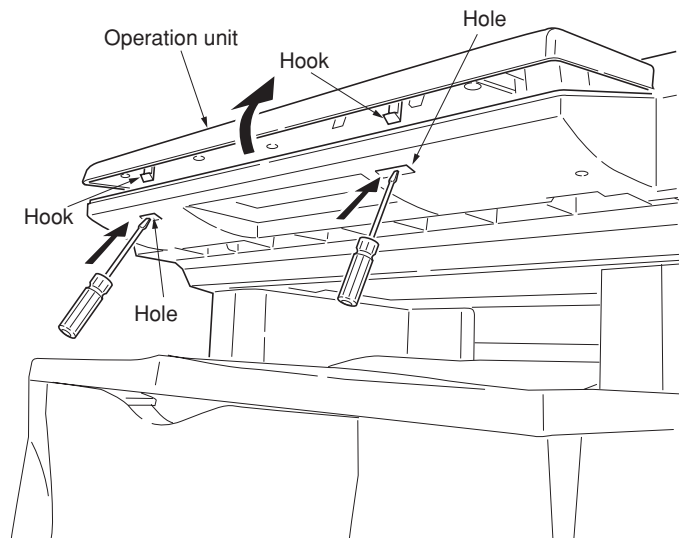

Figure 1-6-35 Removing the operation unit

2. Remove two screws and then remove the original holder cover.

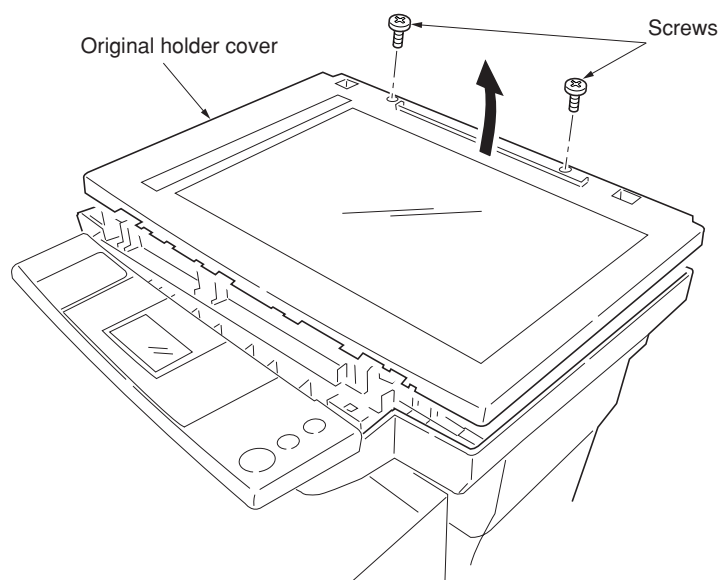

Figure 1-6-36 Removing the original holder cover

3. Remove two screws and then remove two grounding plates.
4. Remove the one stopper ring and then detach the scanner shaft.
- * Detach the shaft taking care to tilt it as little as possible.

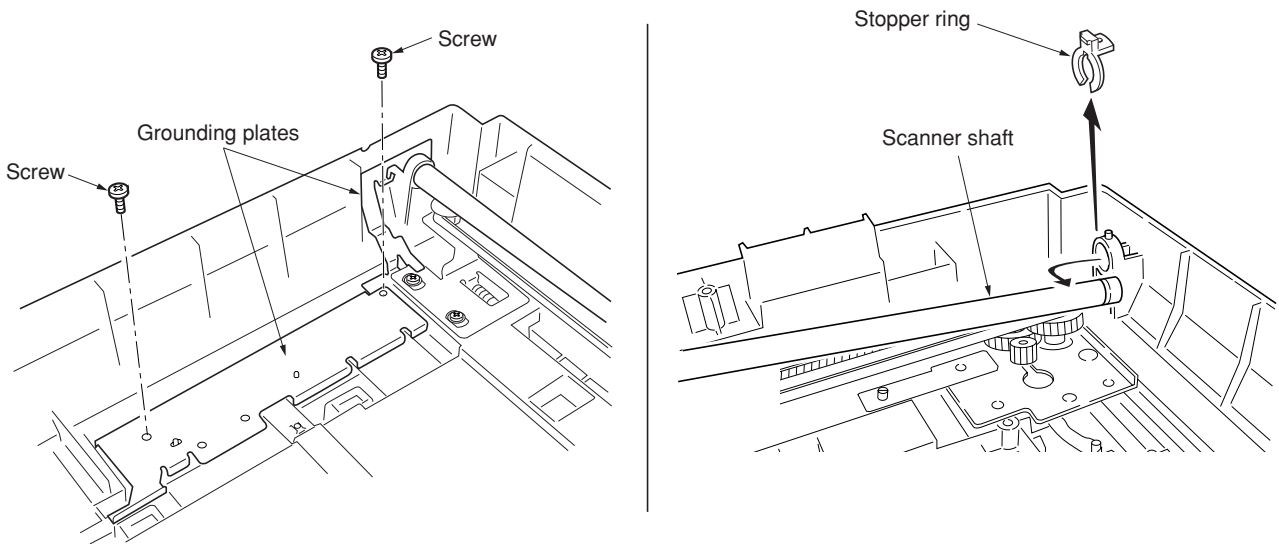

Figure 1-6-37 Detaching the scanner shaft

5. Remove the flexible flat cable from the ISU board's connector.
6. Remove the scanner belt from the belt hook of scanner unit.
7. Remove the ISU unit from the scanner shaft.
- * Remove the ISU unit taking care not to lose the M4 nut located in the ISU unit.

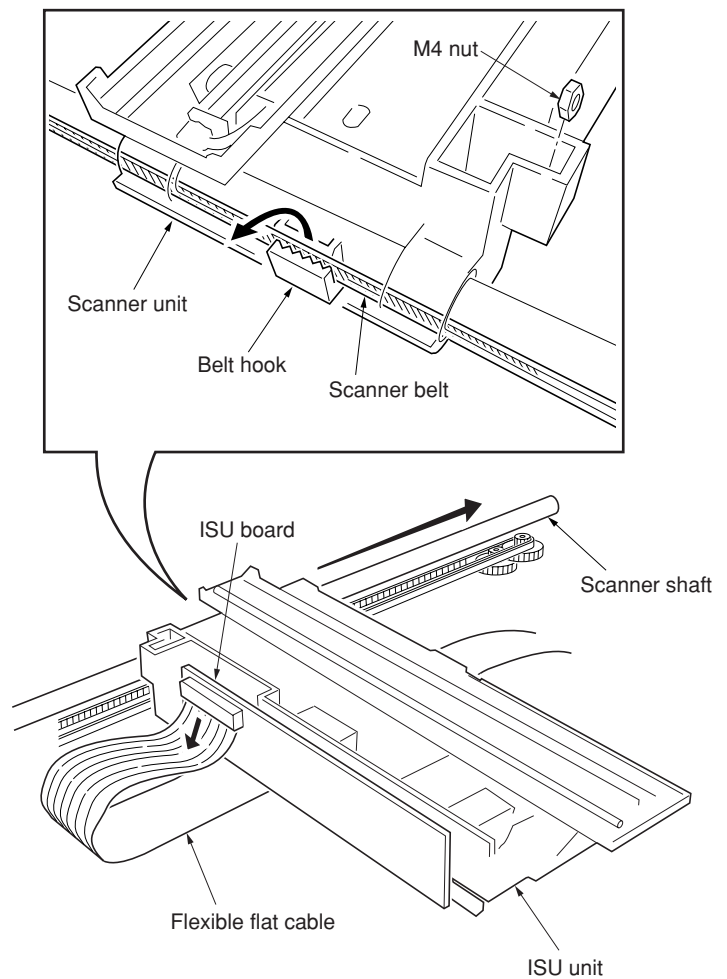

Figure 1-6-38 Removing the ISU unit

1-6-13 Removing the exposure lamp

1. Remove the ISU unit (See page 1-6-32).
2. Remove the two connectors from the inverter board.
3. Remove the one screw and then remove the inverter board.

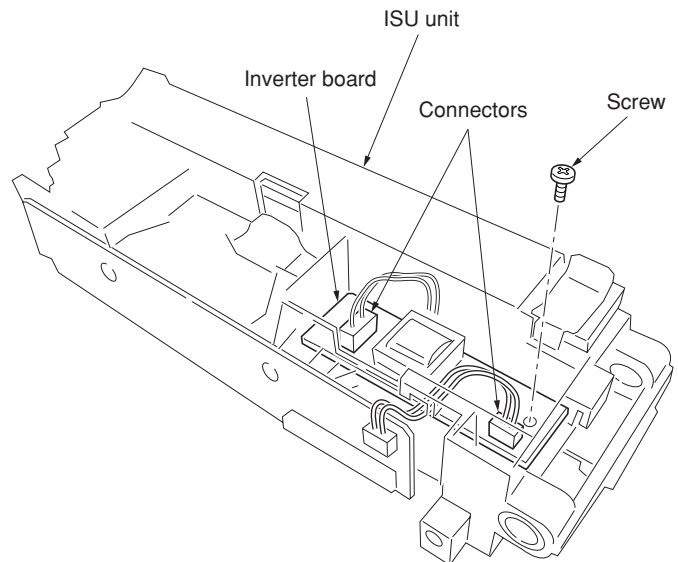

Figure 1-6-39 Removing the inverter board

4. While unhooking the hook and then slide the exposure lamp mount.

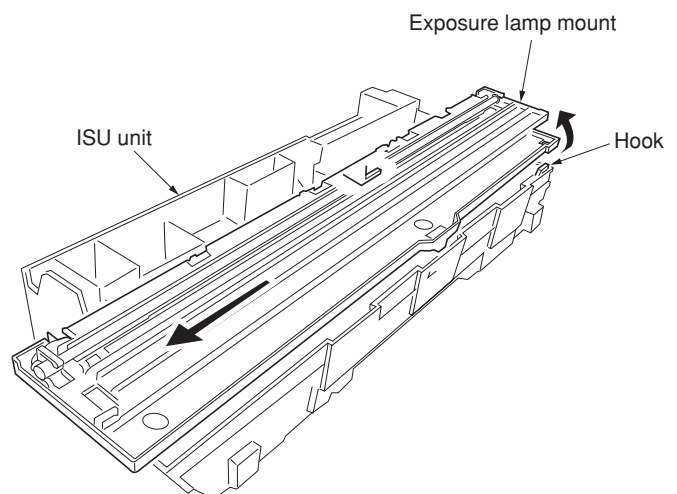

Figure 1-6-40 Removing the exposure lamp mount

5. Remove the exposure lamp and cables from the exposure lamp mount.
 - Do not touch the glass surfaces of the exposure lamp with bare hands.

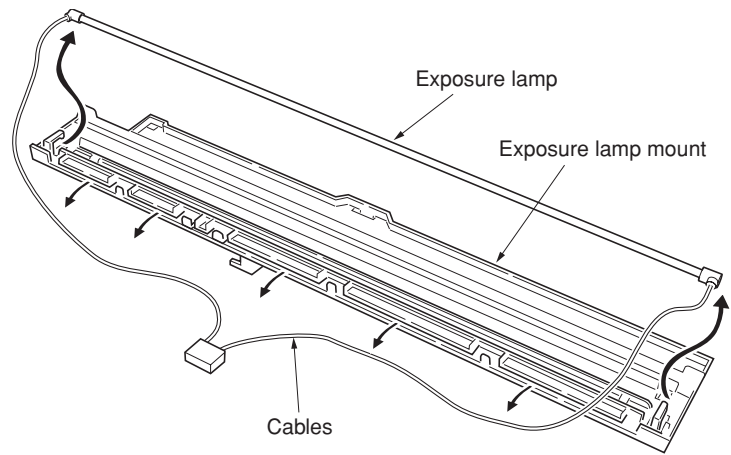

Figure 1-6-41 Removing the exposure lamp

1-6-14 Removing the scanner mirror A

1. Remove the ISU unit (See page 1-6-32).
2. Remove the exposure lamp (See page 1-6-34).
3. Unhook the two mirror A holders and then remove the scanner mirror A.

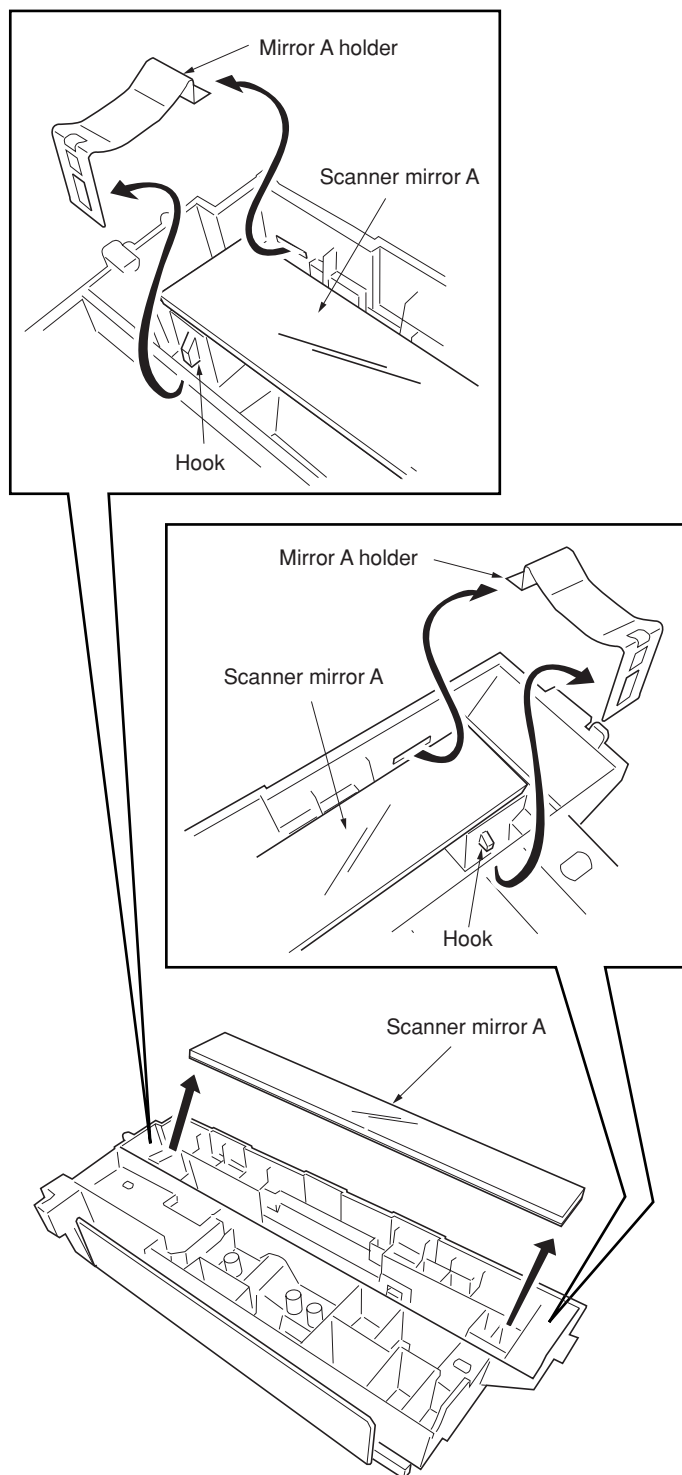

Figure 1-6-42 Removing the scanner mirror A

1-6-15 Removing the scanner motor

1. Remove the original holder cover (See page 1-6-32).
2. Remove the right cover (See page 1-6-4).
3. Remove the speaker (See page 1-6-10).
4. Remove the one connector from the scanner board.

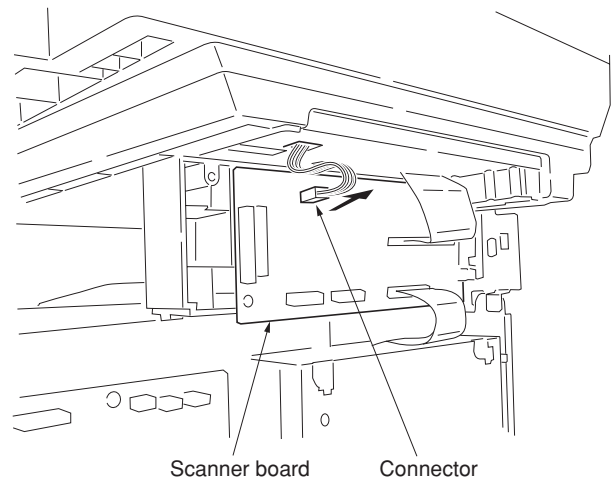

Figure 1-6-43 Removing the scanner motor (1)

5. Remove two screws and then remove two grounding plates.

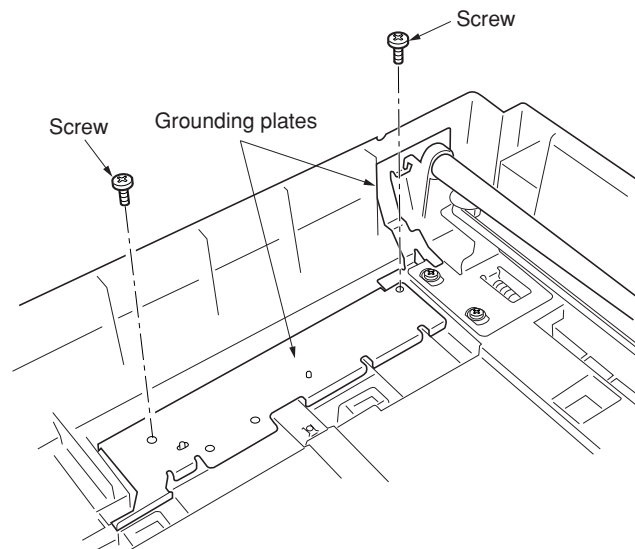

Figure 1-6-44 Removing the scanner motor (2)

6. Loosen two screws and then release the tension of a scanner belt.
7. Remove the scanner belt.

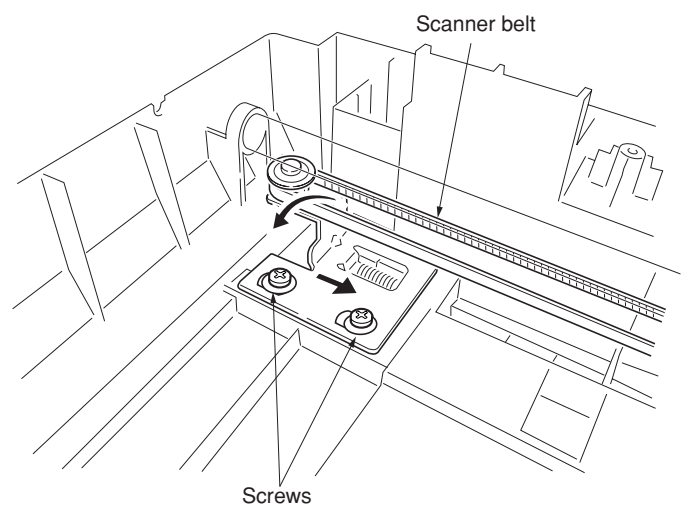

Figure 1-6-45 Removing the scanner motor (3)

2DD

8. Remove three screws and then remove the grounding plate.

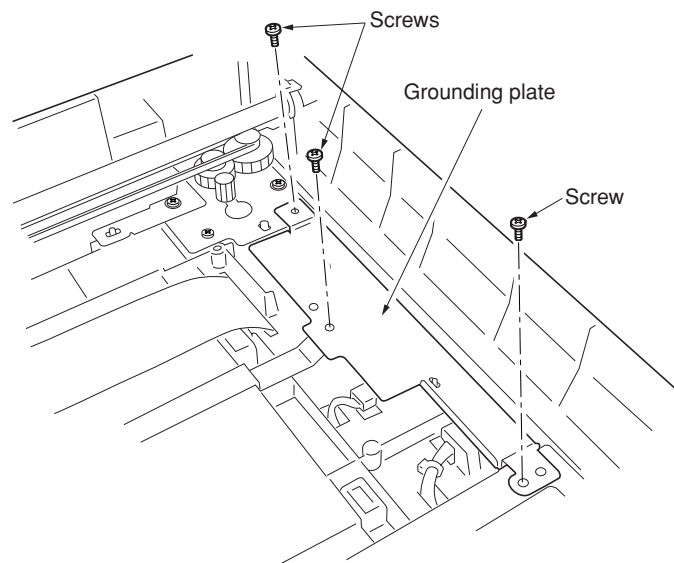

Figure 1-6-46 Removing the scanner motor (4)

9. Remove the one stopper ring and then detach the scanner shaft.
* Detach the shaft taking care to tilt it as little as possible.

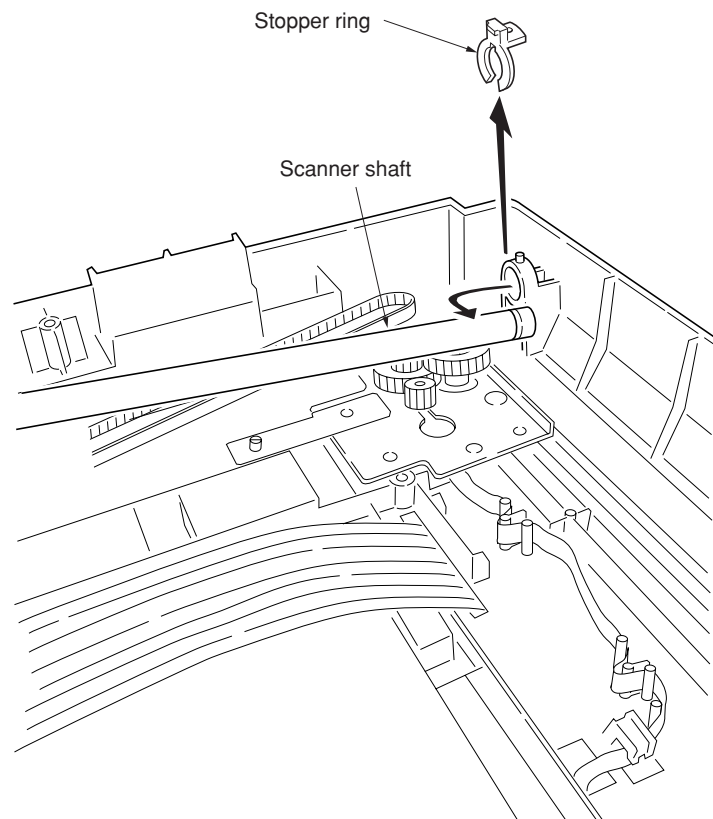

Figure 1-6-47 Removing the scanner motor (5)

10. Remove the cable from the cable clamps.
11. Remove the four screws and then remove the scanner motor mount with scanner motor.

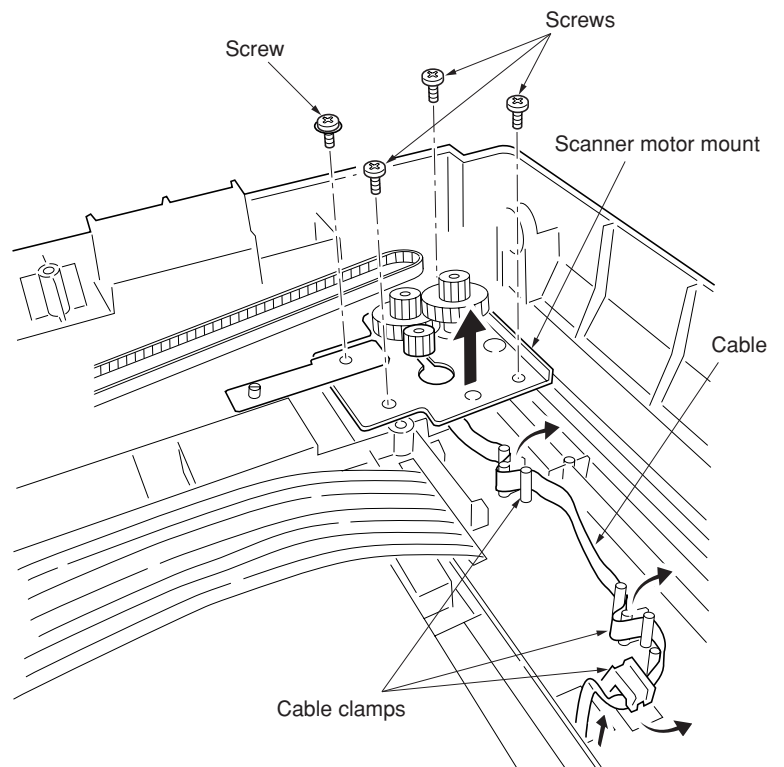

Figure 1-6-48 Removing the scanner motor (6)

12. Remove the one screw and then remove the scanner motor.

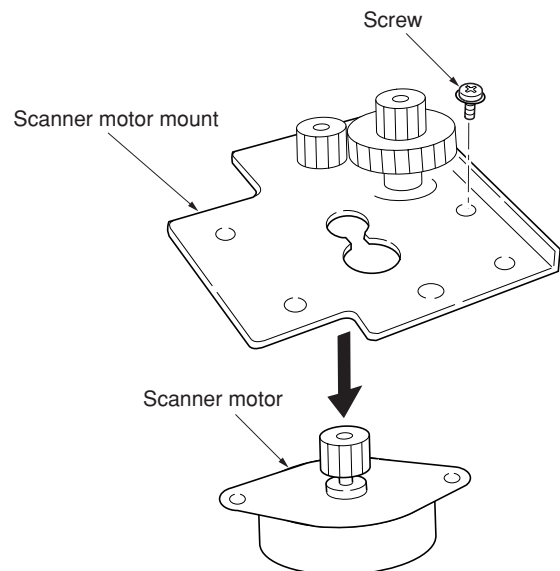

Figure 1-6-49 Removing the scanner motor (7)

1-6-16 Removing the main charger unit

1. Remove the process unit from the machine (See page 1-6-2).
2. Unlatch the three snaps, and remove the main charger cap.
3. Draw the main charger unit in the direction of arrow (A), then pull it out in the direction of arrow (B).

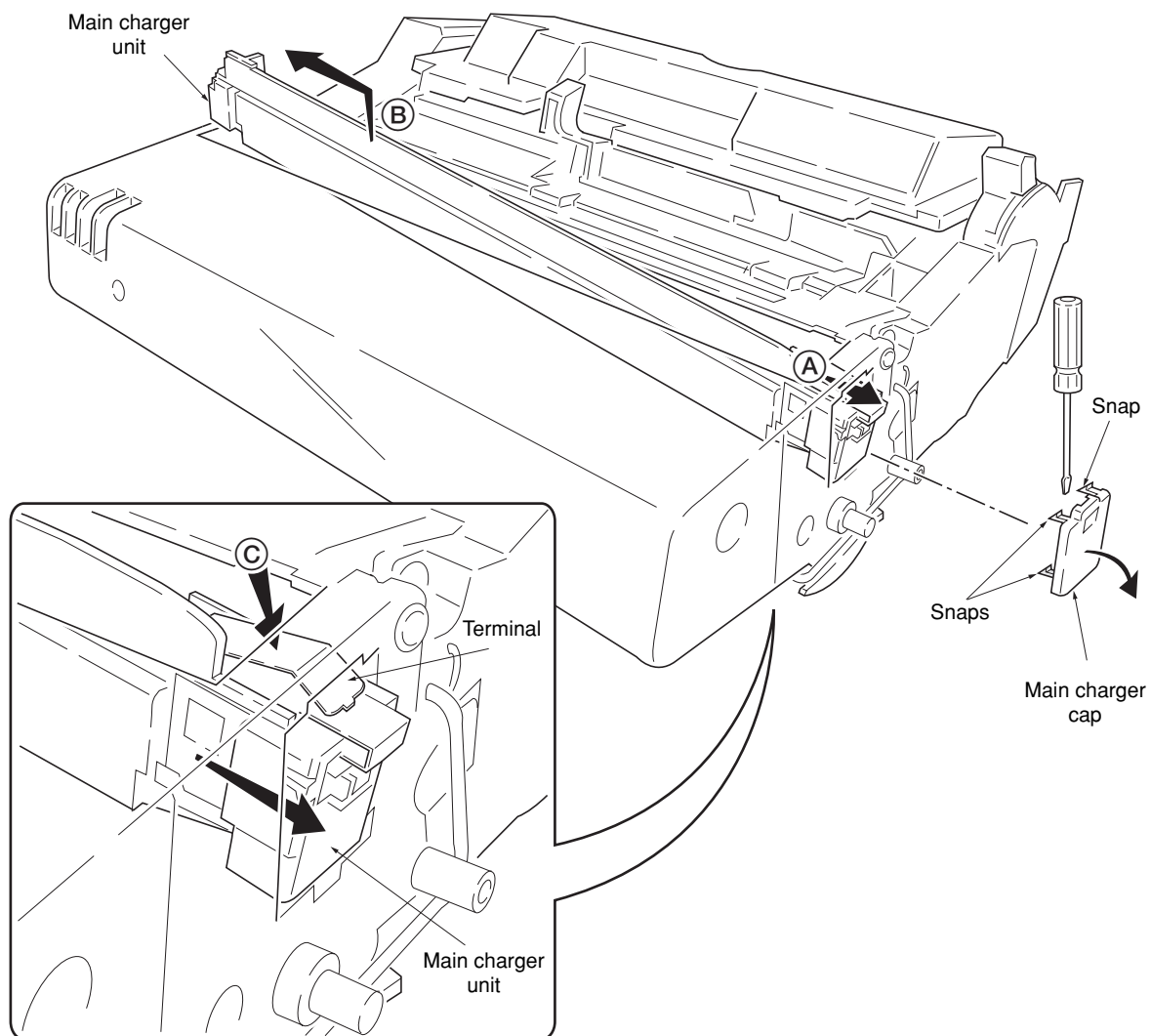

Figure 1-6-50 Removing the main charger unit

CAUTION

- When refitting the main charger unit, hold terminal down (C), then push frontwards. Use care not to deform the terminal.

1-6-17 Adjustment the maintenance mode

(1) Adjusting the leading edge registration of image printing

Make the following adjustment if there is a regular error between the leading edges of the copy image and original.

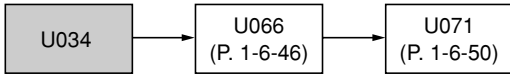

Caution:

Check the copy image after the adjustment. If the image is still incorrect, perform the above adjustments in maintenance mode.

Procedure

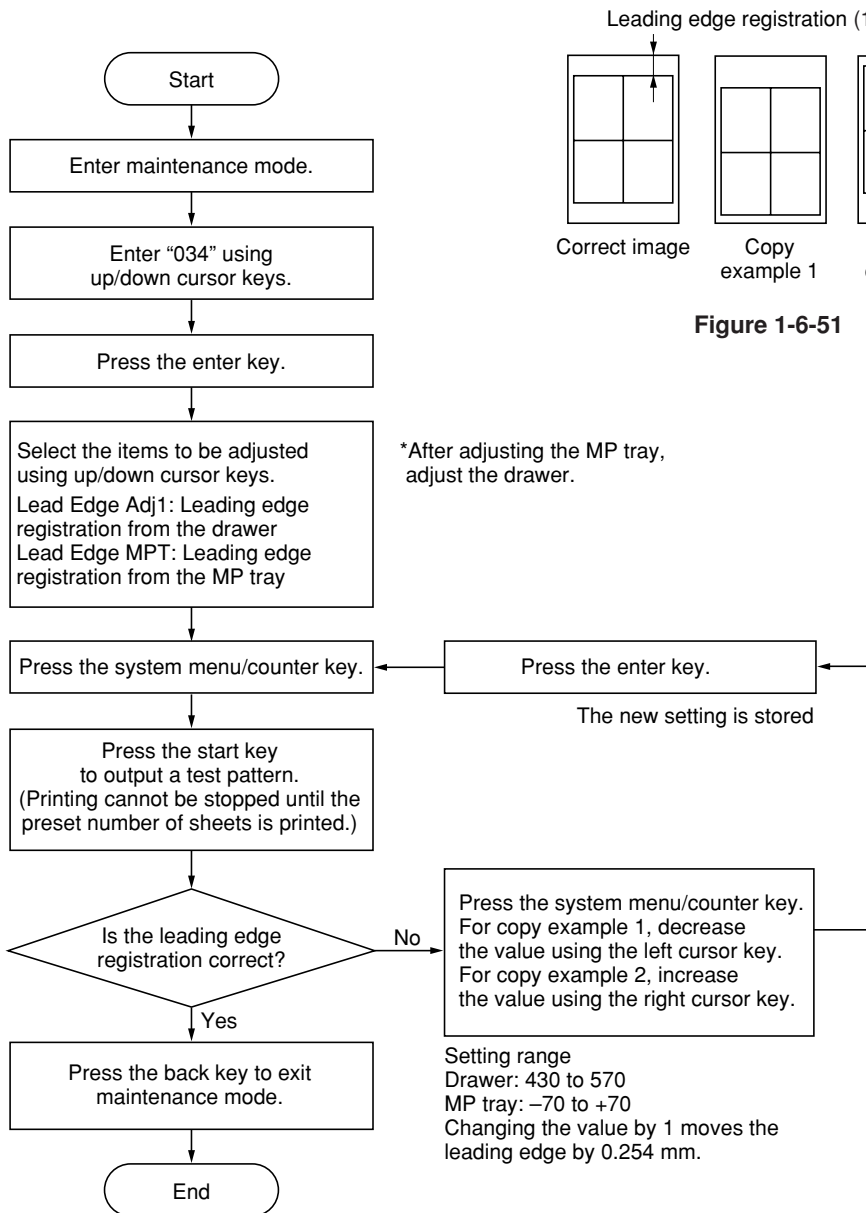

(2) Adjusting the center line of image printing

Make the following adjustment if there is a regular error between the center lines of the copy image and original when paper is fed from the drawer.

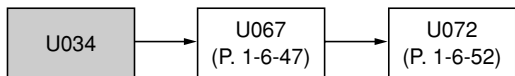

Caution:

Check the copy image after the adjustment. If the image is still incorrect, perform the above adjustments in maintenance mode.

Procedure

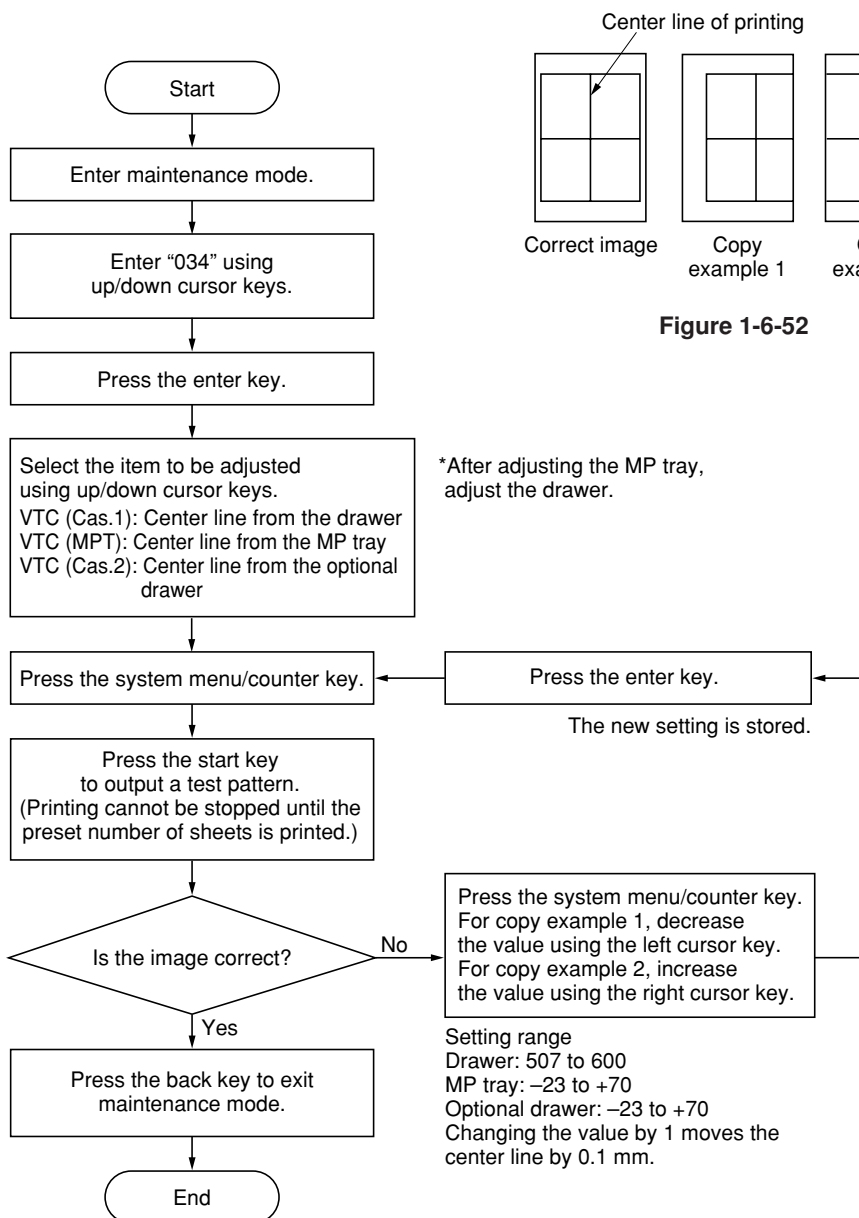

(3) Adjusting the amount of slack in the paper

Make the following adjustment if the leading edge of the copy image is missing or varies randomly, or if the copy paper is Z-folded.

Procedure

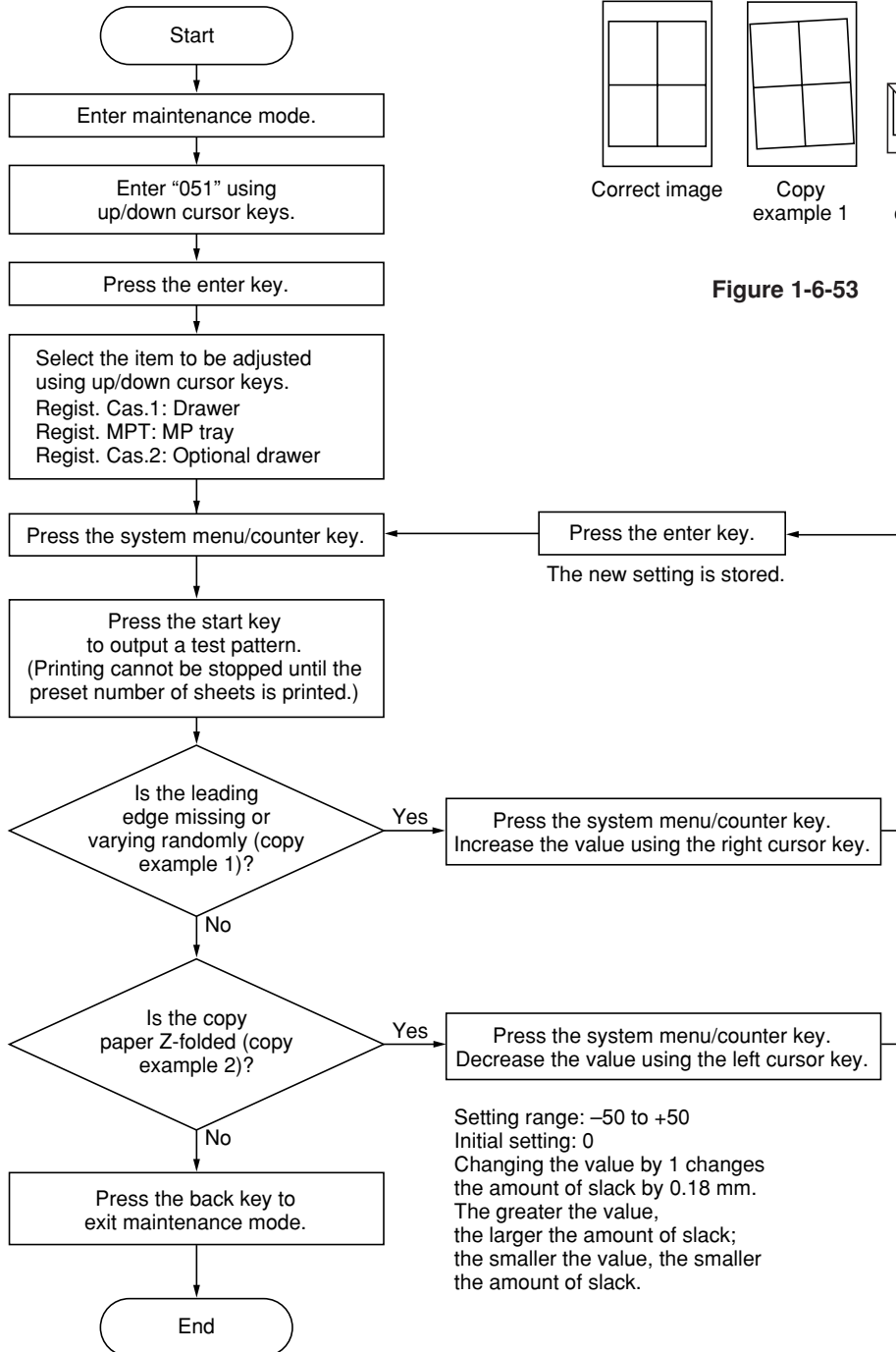

(4) Adjusting magnification of the scanner in the main scanning direction

Perform the following adjustment if the magnification in the main scanning direction is not correct.

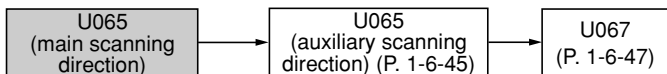

Caution:

Before making the following adjustment, ensure that the above adjustments have been made in maintenance mode. Also, perform “(5) Adjusting magnification of the scanner in the auxiliary scanning direction” (page 1-6-45) and “(7) Adjusting the scanner center line” (page 1-6-47) after this adjustment.

Procedure

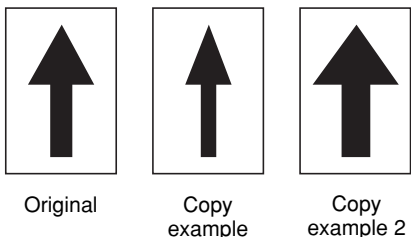
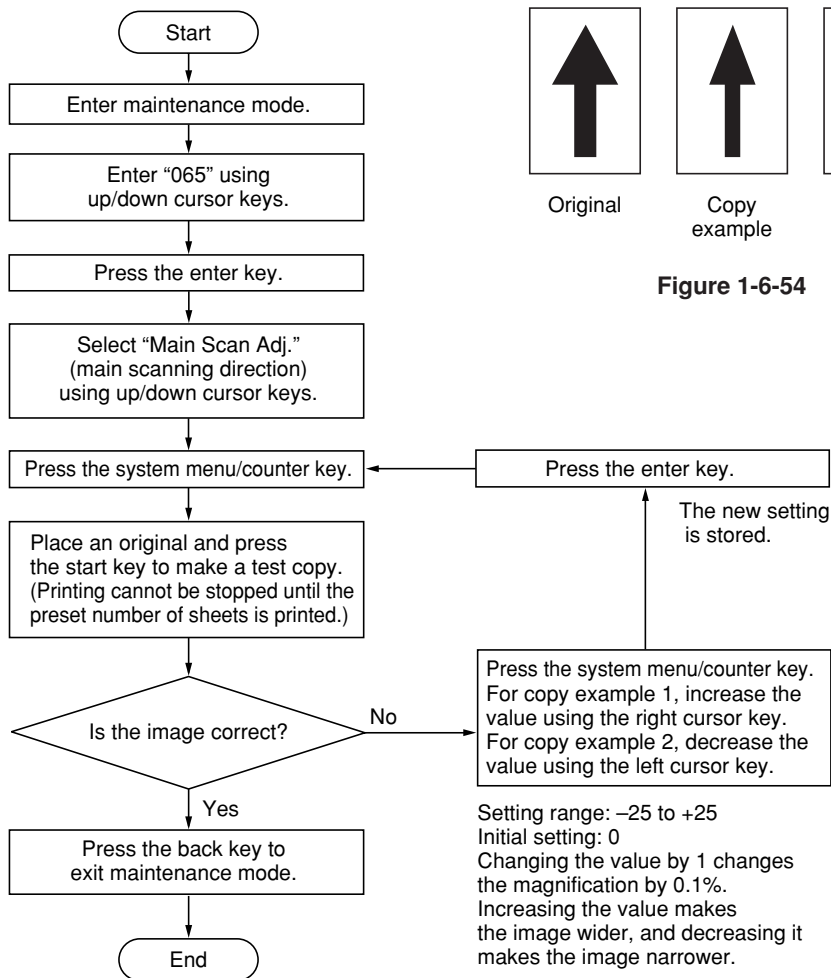

(5) Adjusting magnification of the scanner in the auxiliary scanning direction

Perform the following adjustment if the magnification in the auxiliary scanning direction is not correct.

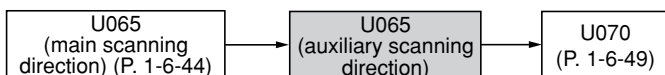

Caution:

Before making the following adjustment, ensure that the above adjustments have been made in maintenance mode.

Procedure

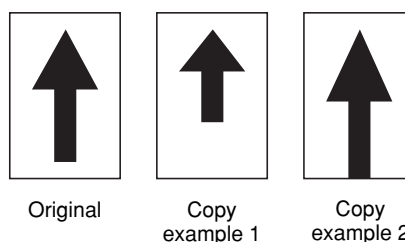
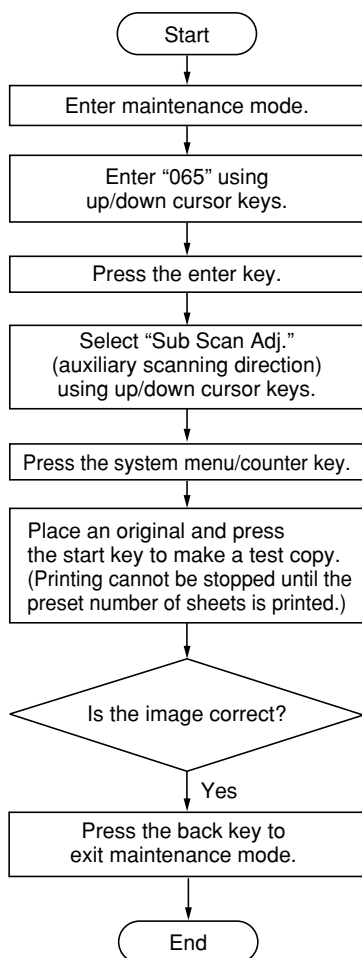
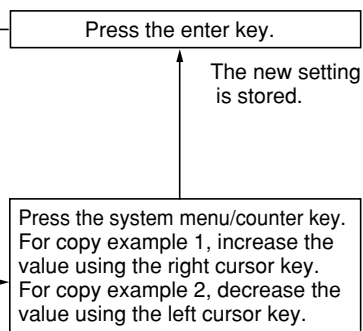

Figure 1-6-55



Setting range: -25 to +25
 Initial setting: 0
 Changing the value by 1 changes the magnification by 0.1%.
 Increasing the value makes the image longer, and decreasing it make the image shorter.

(6) Adjusting the scanner leading edge registration

Perform the following adjustment if there is regular error between the leading edges of the copy image and original.

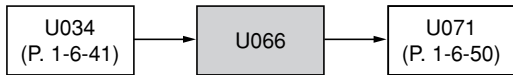

Caution:

Before making the following adjustment, ensure that the above adjustments have been made in maintenance mode.

Procedure

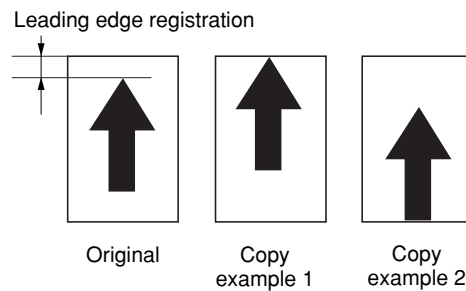
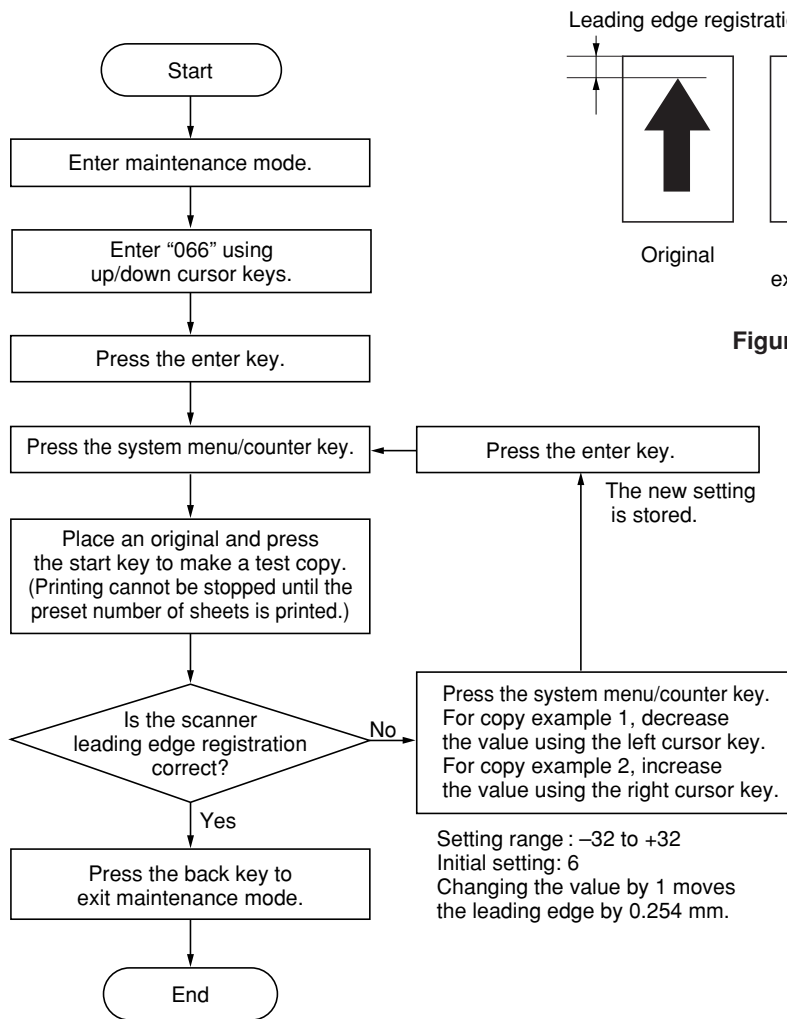

Figure 1-6-56

Setting range : -32 to +32
 Initial setting: 6
 Changing the value by 1 moves the leading edge by 0.254 mm.

(7) Adjusting the scanner center line

Perform the following adjustment if there is a regular error between the center lines of the copy image and original.



Caution:

Before making the following adjustment, ensure that the above adjustments have been made in maintenance mode.

Procedure

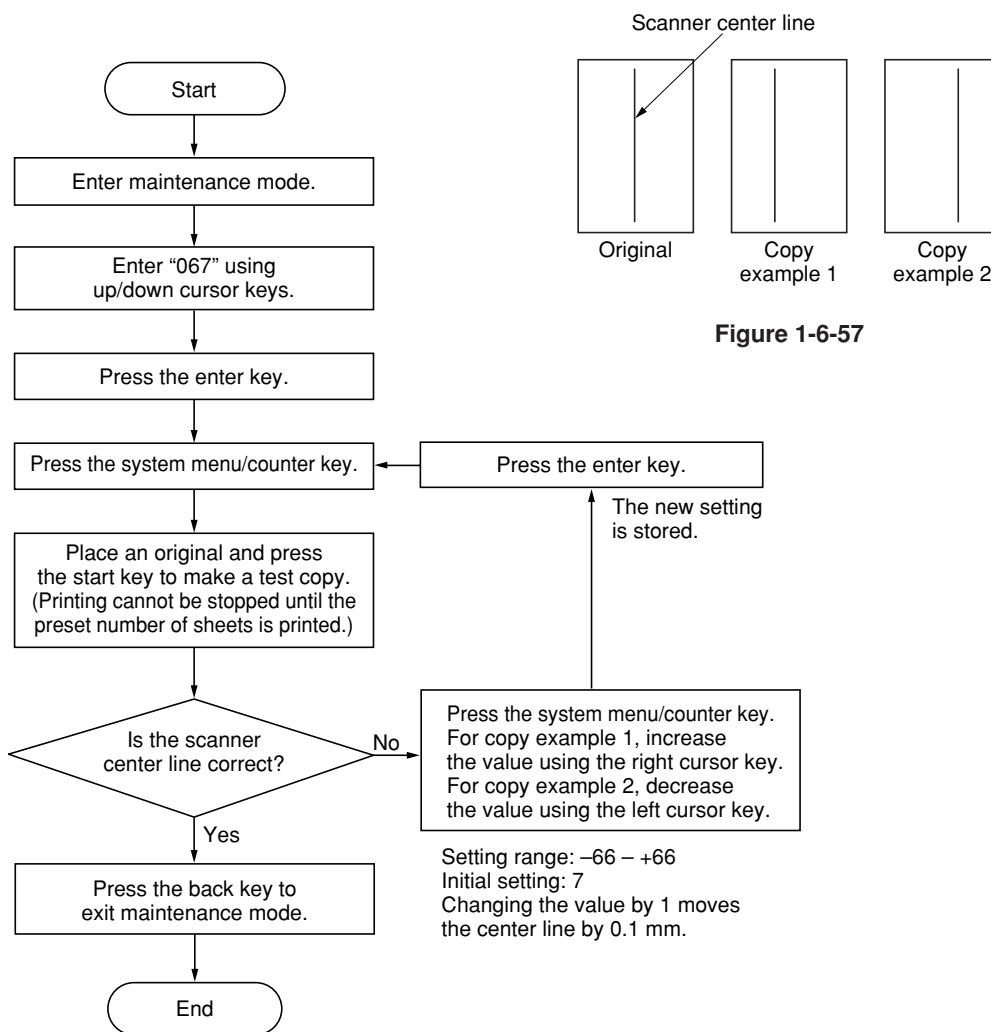

(8) Adjusting the margins for scanning an original on the contact glass

Perform the following adjustment if the margins are not correct.

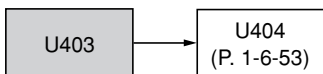

Caution:

Check the copy image after the adjustment. If the image is still incorrect, perform the above adjustments in maintenance mode.

Procedure

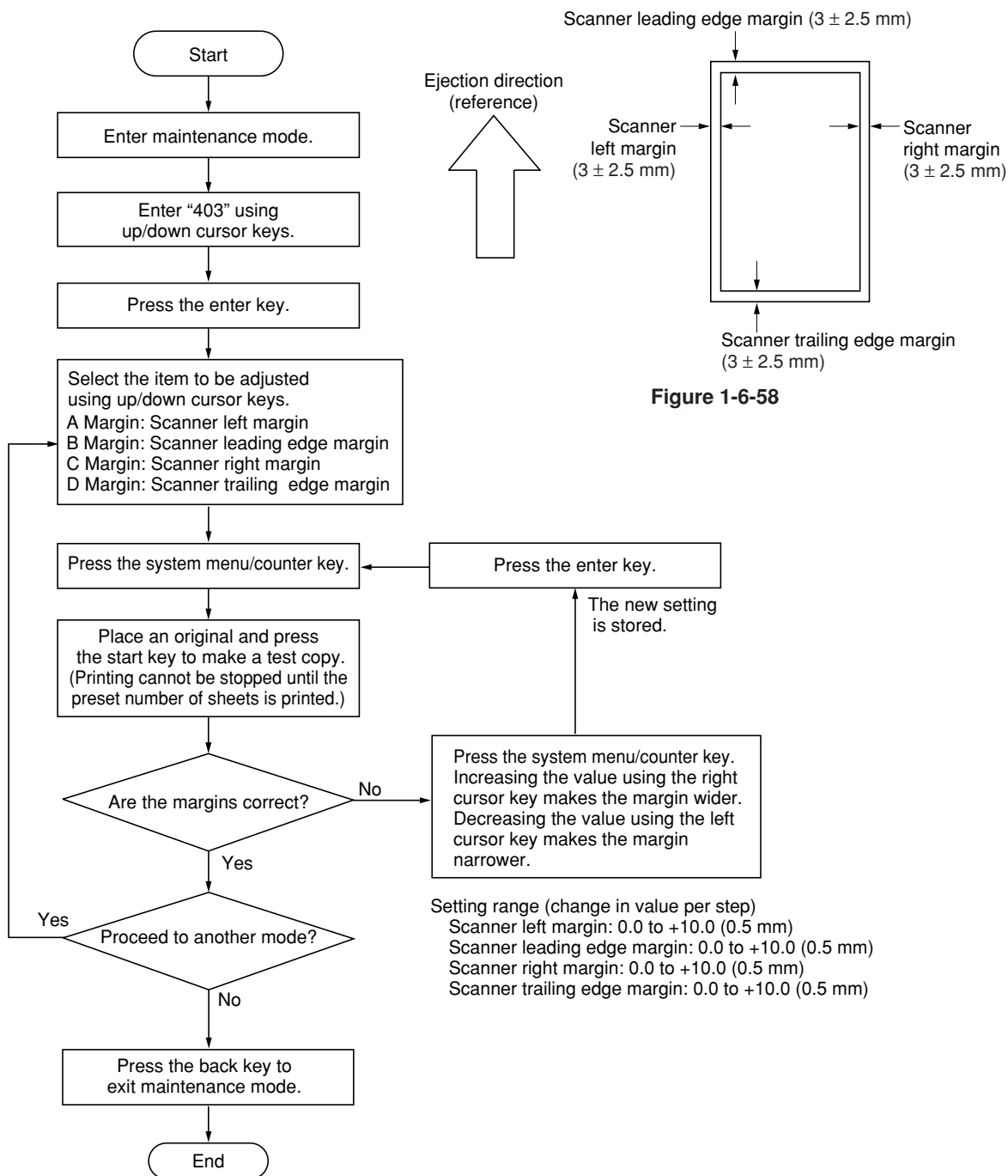

(9) Adjusting the DP magnification

Adjust magnification in the auxiliary scanning direction if magnification is incorrect when the DP is used.

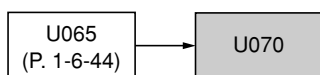
**Caution:**

Before making the following adjustment, ensure that the above adjustments have been made in maintenance mode.

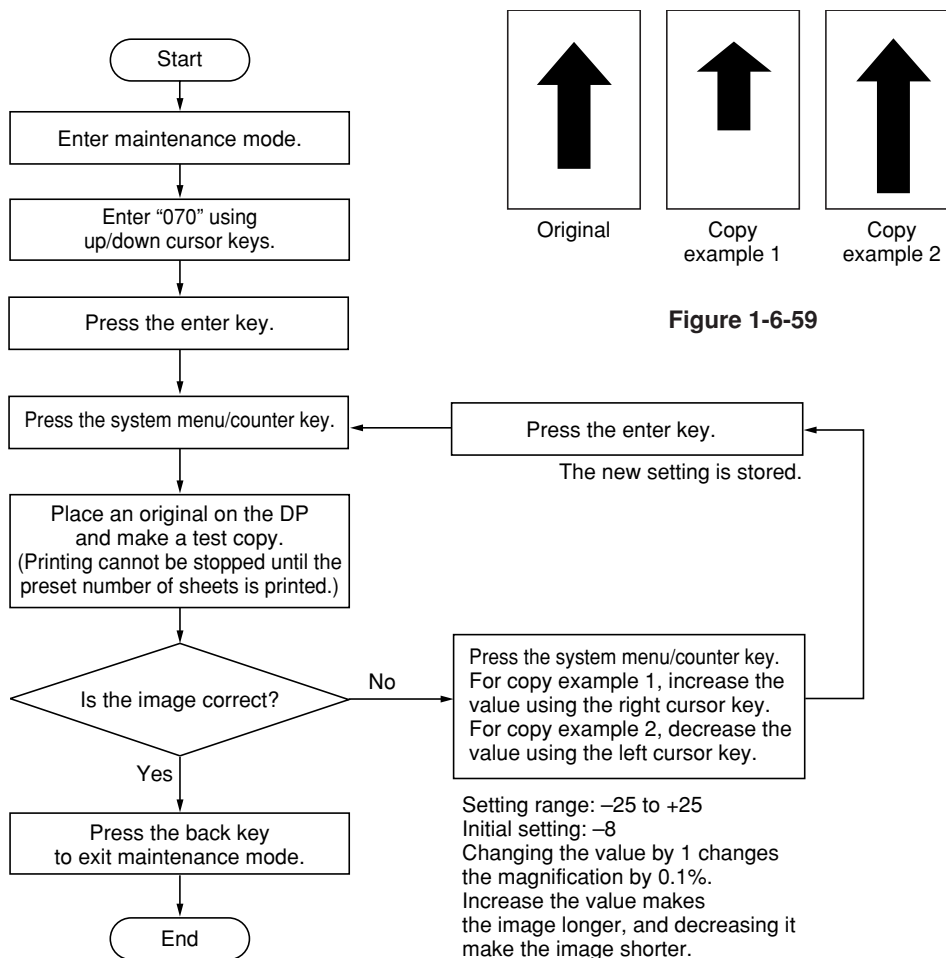
Procedure

(10) Adjusting the DP leading edge registration

Perform the following adjustment if there is a regular error between the leading edge of the original and the copy image.

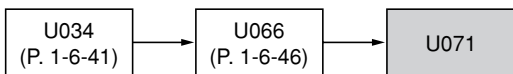

Caution:

Before making the following adjustment, ensure that the above adjustments have been made in maintenance mode.

Procedure

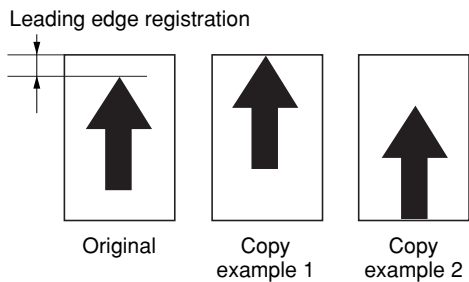
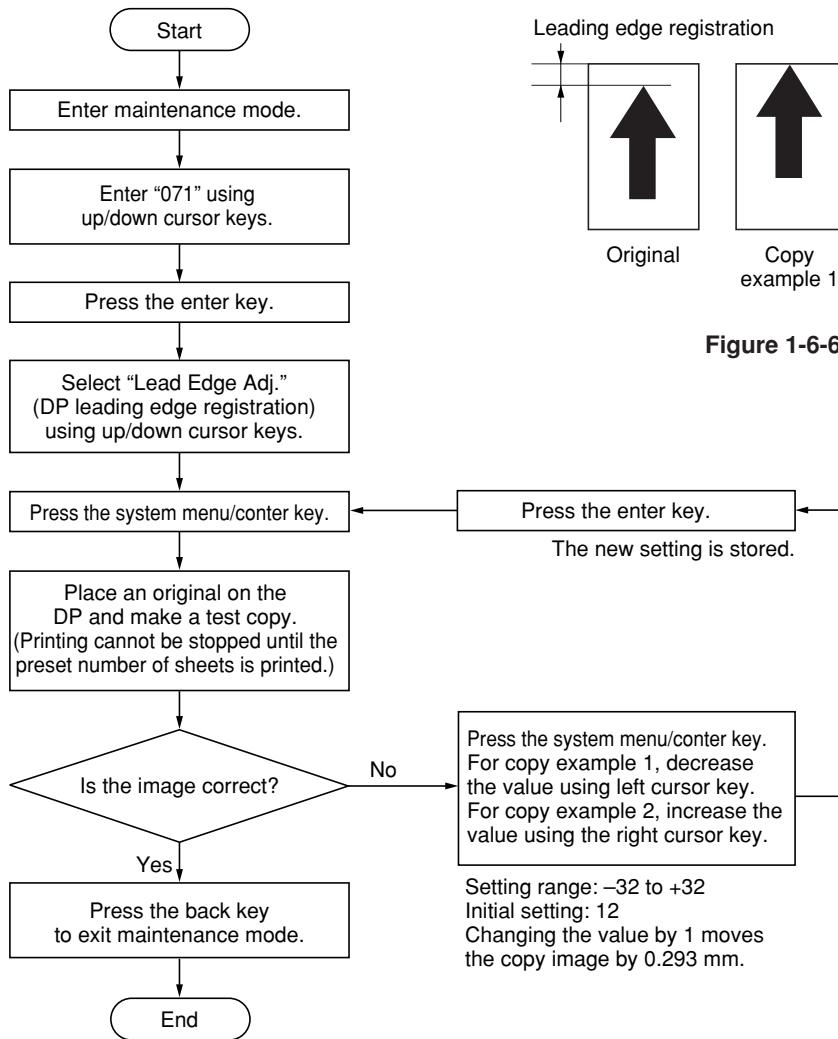

Figure 1-6-60

Press the system menu/conter key.
For copy example 1, decrease the value using left cursor key.
For copy example 2, increase the value using the right cursor key.

Setting range: -32 to +32
Initial setting: 12
Changing the value by 1 moves the copy image by 0.293 mm.

(11) Adjusting the DP trailing edge registration

Perform the following adjustment if the original scanning end position is not correct when the DP is used.

Caution:

If the copy image looks like copy example 2, clean the DP original scanning section.

Procedure

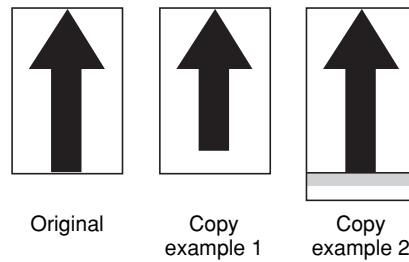
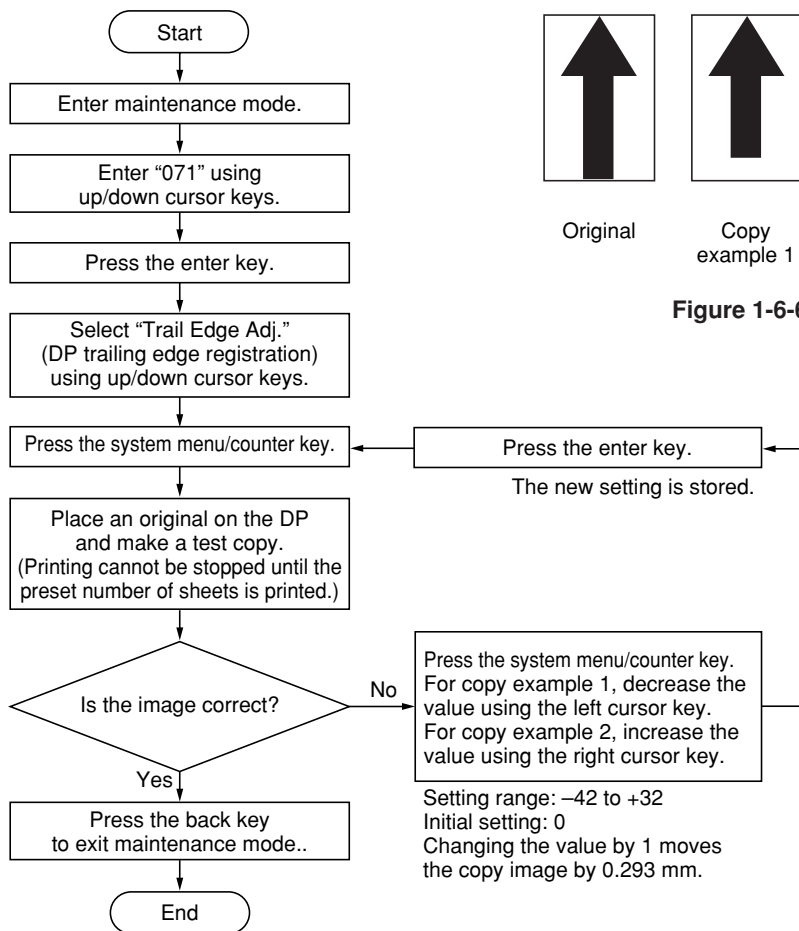
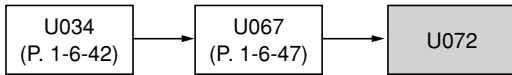

Figure 1-6-61

(12) Adjusting the DP center line

Perform the following adjustment if there is a regular error between the centers of the original and the copy image.



Caution:

Before making the following adjustment, ensure that the above adjustments have been made in maintenance mode.

Procedure

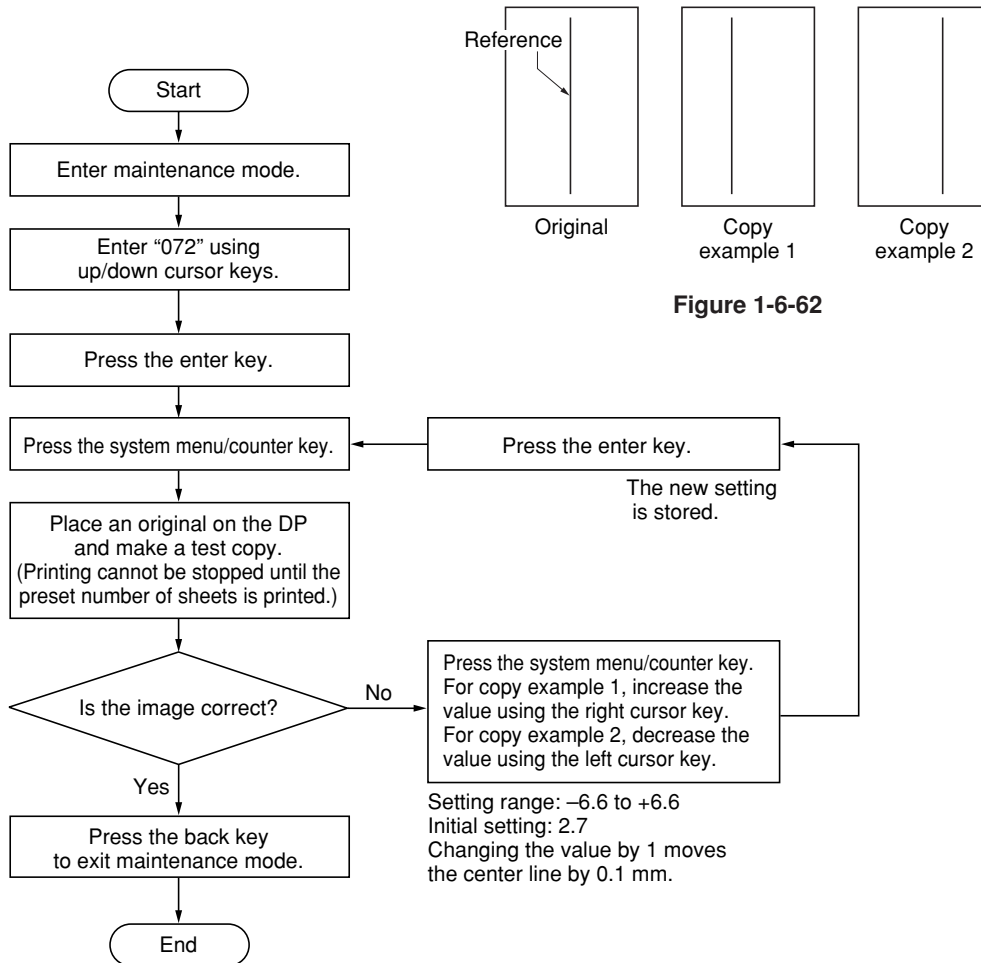
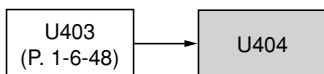

Figure 1-6-62

(13) Adjusting the margins for scanning the original from the DP

Perform the following adjustment if margins are not correct.



Caution:

Before making the following adjustment, ensure that the above adjustments have been made in maintenance mode.

Procedure

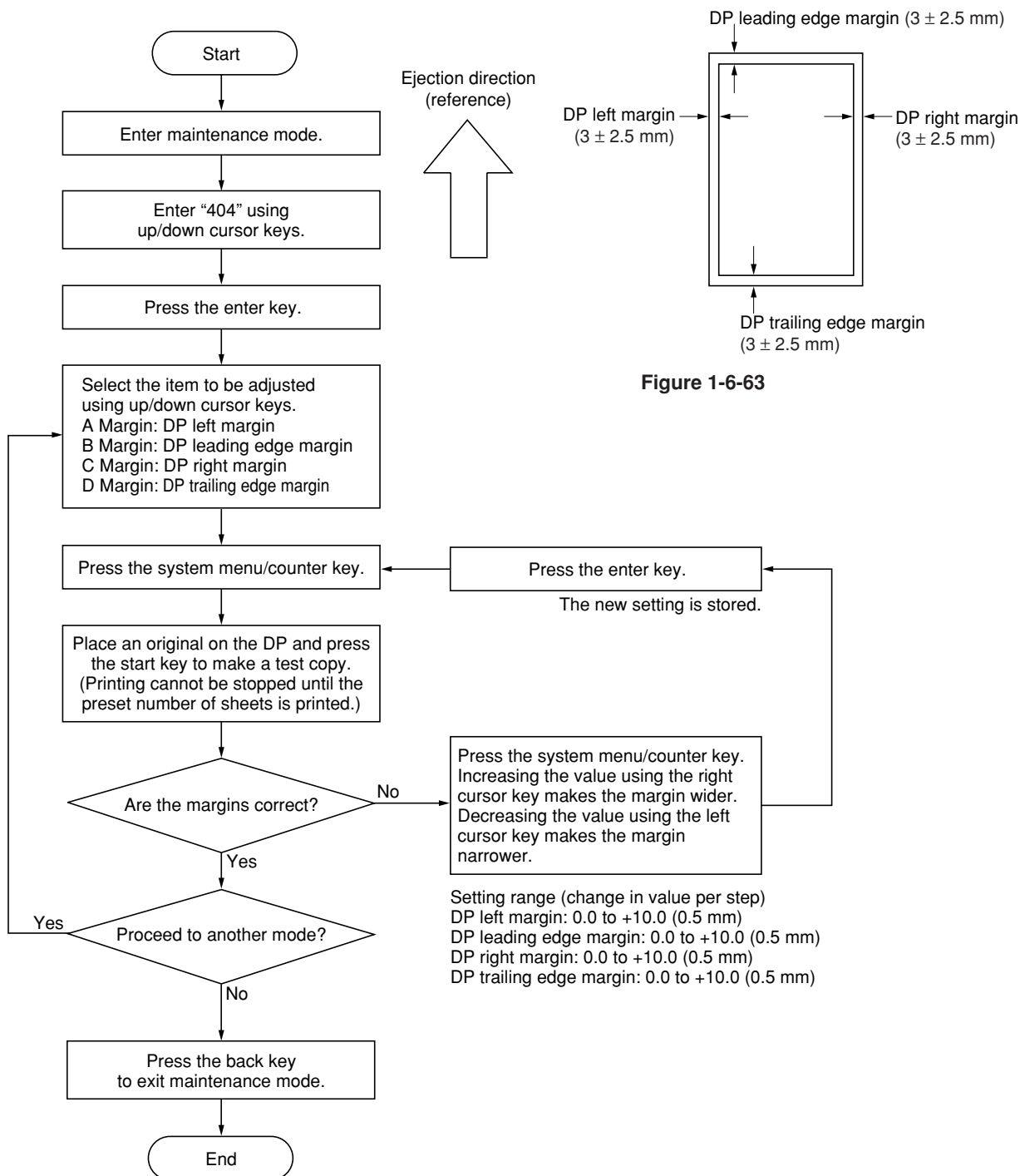

1-7-1 Upgrading the firmware on the main board

• When using Compact Flash

Firmware upgrading requires the following tools:

Compact Flash (Products manufactured by SANDISK are recommended.)

NOTE

- When writing data from a computer to a new Compact Flash, be sure to format it from the computer in advance.
- Since the data is supplied with a compressed file, extract the data and then write it to the Compact Flash.
- Do not write data other than the files below to the Compact Flash.

Folder

NANDinstall: NAND side Install command group

NORinstall: NOR side Install command group

File

Initrd: Initialization processing file

PPCBoot: Boot program

RootDiskImage.jffs2: Controller program

SetupDiskImage.jffs2: Controller program setting file

VERDEF: Configuration file

zImage.kmmfp: Kernel program

Procedure

1. Turn the power switch off and disconnect the power plug.
2. Remove the one pin and then remove the memory cover.
3. Remove the two screws and then remove the CF cover.
4. Insert Compact Flash in a CF slot on the main board.
 - * Insert it straight all the way into the machine with the front side facing the rear of the machine. If the power switch is turned on when the Compact Flash is not properly inserted, the main board may be damaged.
5. Insert the power plug and turn the power switch on.

* "Downloading" is displayed on the operation panel and firmware upgrade operation will start. (for approximately 2 minutes)

Caution:

Never turn the power switch off during upgrading.

6. "Completed" is displayed on the operation panel when upgrading is complete.
7. Turn the power switch off and disconnect the power plug.
8. Remove Compact Flash from the main board.
9. Refit the CF cover and memory cover.
10. Insert the power plug and turn the power switch on.

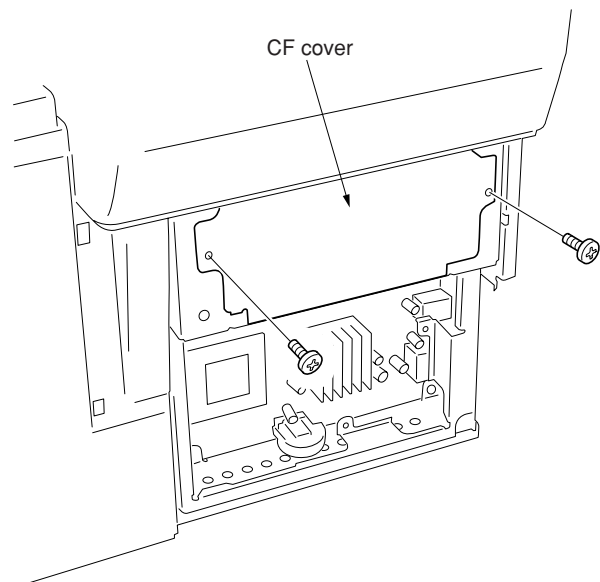

Figure 1-7-1

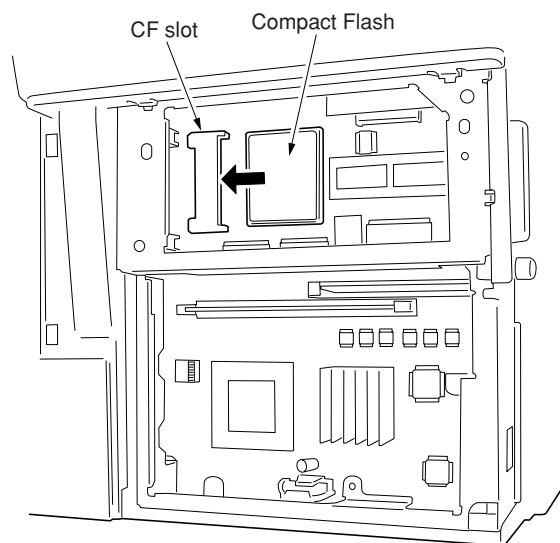

Figure 1-7-2

• **When replacing DIMM**

Firmware upgrading requires the following tools:
DIMM (P/N 2DD01080)

Procedure

1. Turn the power switch off and disconnect the power plug.
2. Remove the one pin and then remove the memory cover.
3. Remove the DIMM from the DIMM slot on the main board.
4. Insert the new DIMM into the DIMM slot on the main board.
* Insert the DIMM securely all the way into the slot. If the power switch is turned on when the DIMM is not properly inserted, the main board may be damaged.
5. Refit the memory cover.
6. Insert the power plug and turn the power switch on.

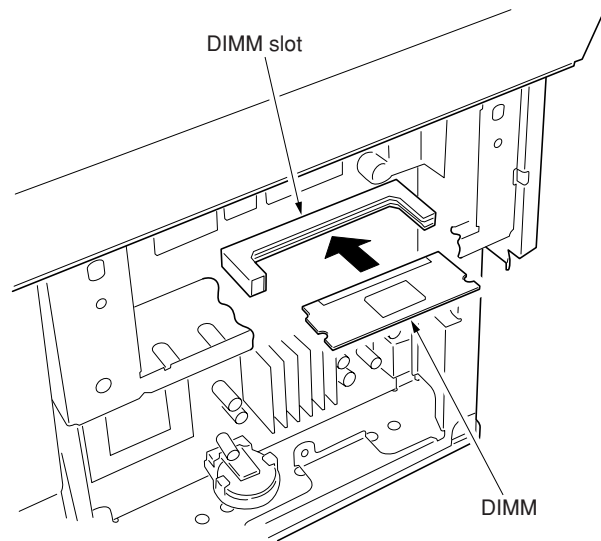

Figure 1-7-3

2-1-1 Paper feeding system

The paper feeding system picks up paper from the cassette, MP tray, or if installed, the paper feeder, feeds it in the machine, and delivers in the output tray. Paper is fed at the precise timing in synchronization with data processing. The paper feeding system finally delivers the printed page to either the face-down or face-up tray as manipulated by the user.

The figure below shows the components in the paper feeding system and the paths through which the paper travels. The sensors, clutches, etc., are described in the following pages.

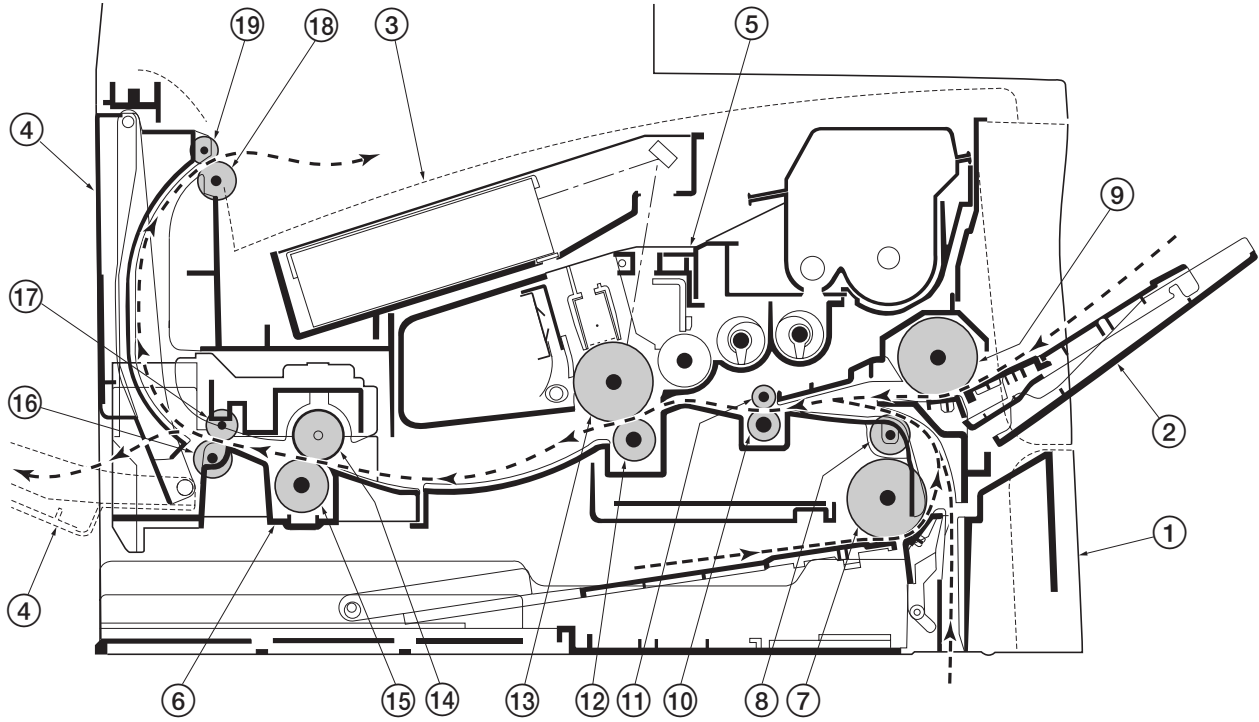
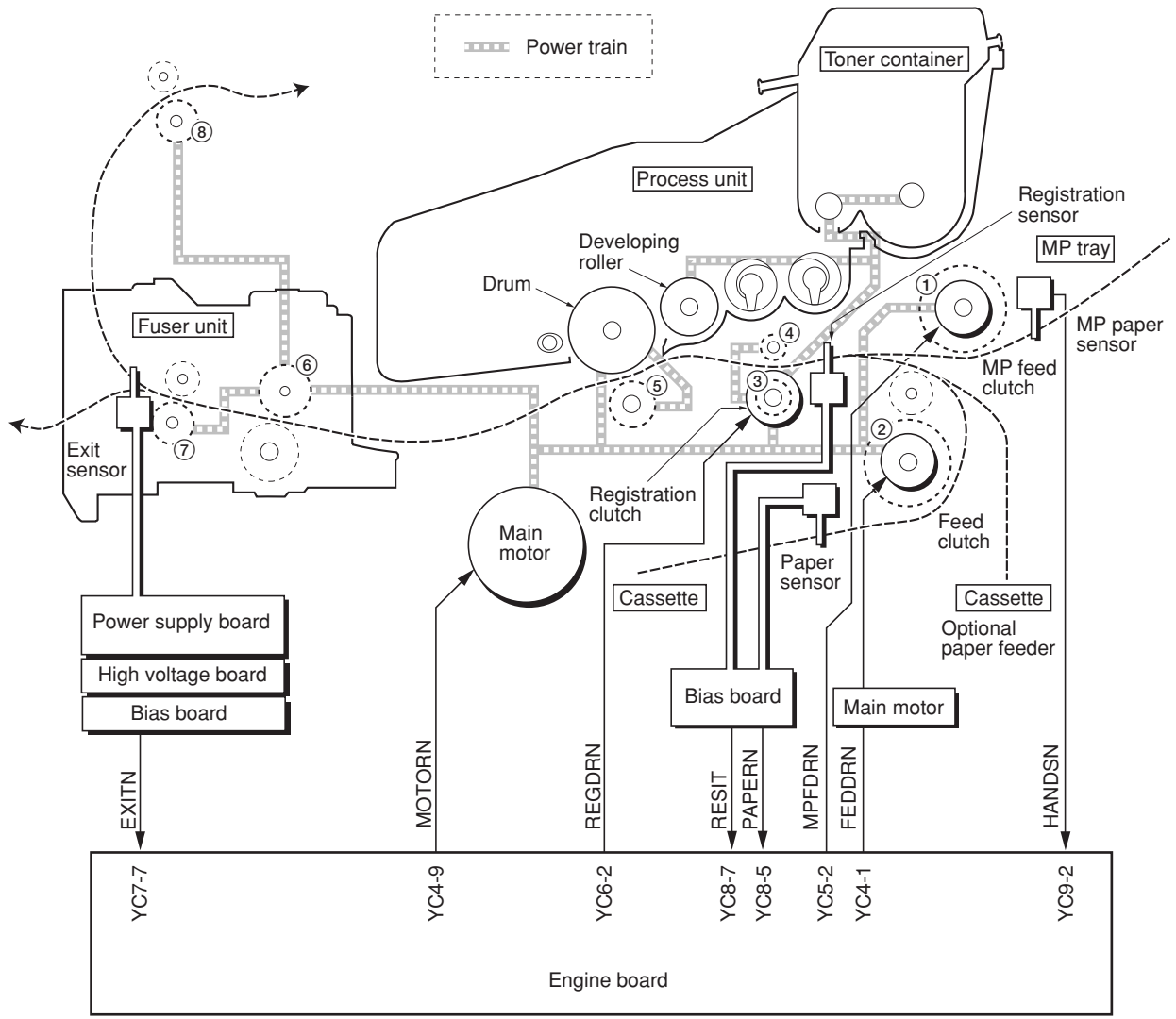

Figure 2-1-1 Paper feeding path

- | | |
|-----------------------------|-----------------------------|
| ① Cassette | ⑪ Upper registration roller |
| ② MP tray | ⑫ Transfer roller |
| ③ Face-down output tray | ⑬ Drum |
| ④ Face-up output tray | ⑭ Heat roller |
| ⑤ Process unit | ⑮ Press roller |
| ⑥ Fuser unit | ⑯ Lower exit roller |
| ⑦ Feed roller | ⑰ Exit pulley |
| ⑧ Feed pulley | ⑱ Upper exit roller |
| ⑨ MP feed roller | ⑲ Exit pulley |
| ⑩ Lower registration roller | |

(1) Paper feed control

The following diagram shows interconnectivity of the feeding system components including the sensors and rollers. The engine board provides the signals in conjunction with the electrophotography process that is driven by the main board.



- ① MP feed roller ② Feed roller ③ Lower registration roller ④ Upper registration roller
- ⑤ Transfer roller ⑥ Heat roller ⑦ Lower exit roller ⑧ Upper exit roller

Figure 2-1-2 Paper feed control

(2) Paper feeding mechanism

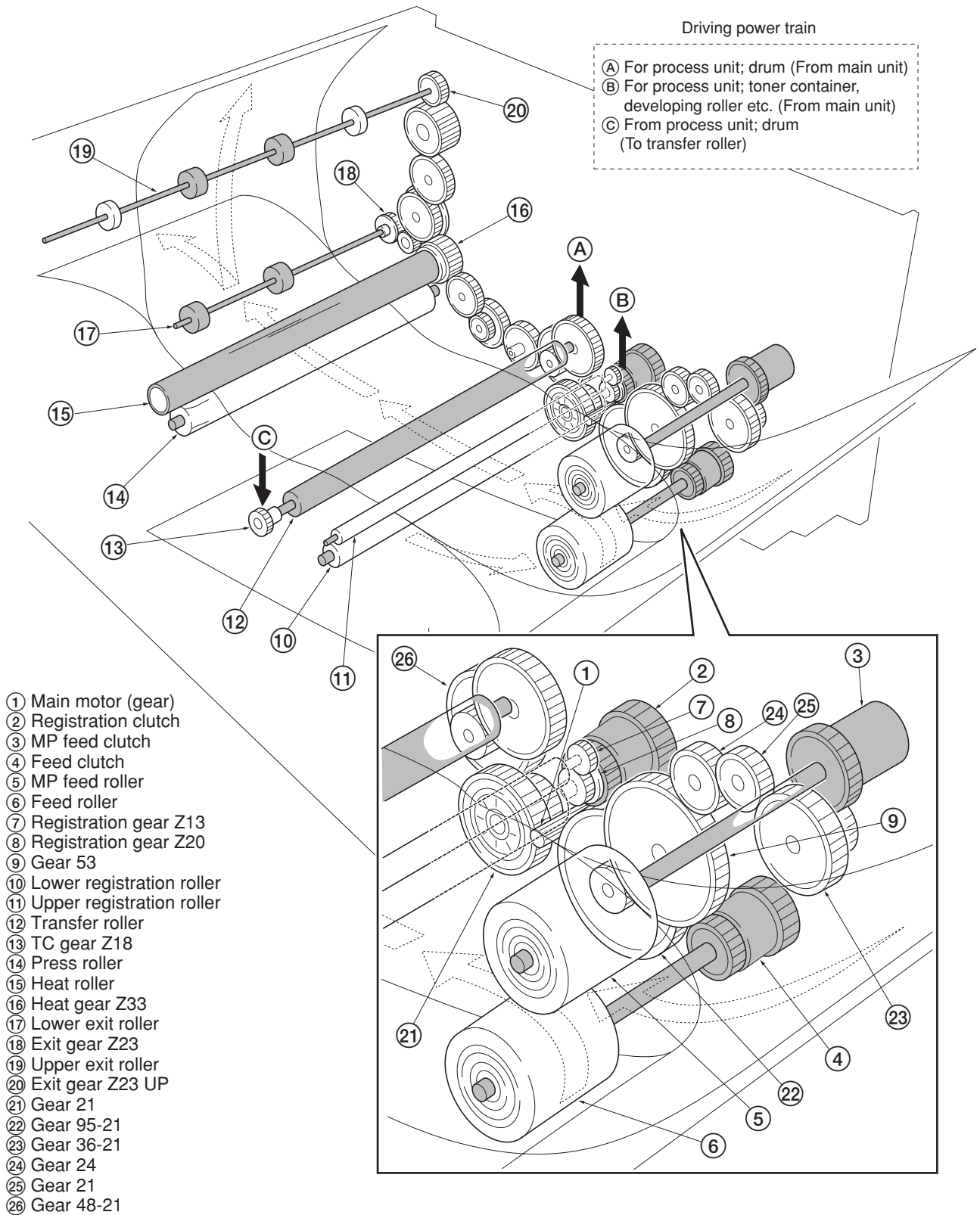

Figure 2-1-3 Paper feeding mechanism

2-1-2 Original scanning system

The scanner unit consists of the image scanning unit (ISU) for main-direction scanning, and drive part for traveling the ISU unit to sub-direction.

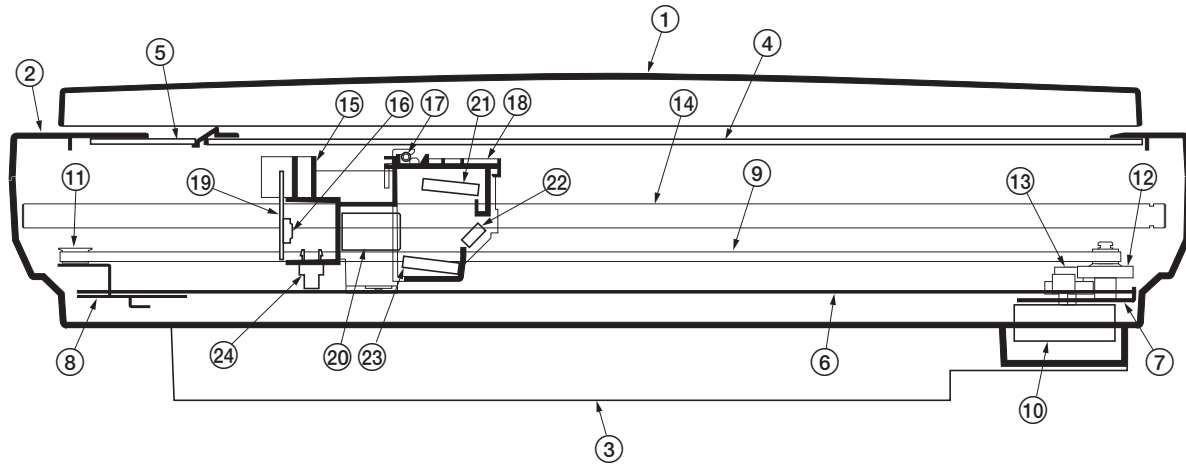

Figure 2-1-4 Scanner unit

- | | |
|------------------------|--------------------------------|
| ① Original holder | ⑬ Scanner gear 39/22 |
| ② Scanner upper frame | ⑭ Scanner shaft |
| ③ Scanner lower frame | ⑮ ISU housing |
| ④ Contact glass | ⑯ CCD image sensor |
| ⑤ DP Contact glass | ⑰ Exposure lamp |
| ⑥ Scanner rail | ⑱ Exposure lamp mount |
| ⑦ Scanner motor mount | ⑲ CCD board |
| ⑧ Tension pulley mount | ⑳ ISU lens |
| ⑨ Scanner belt | ㉑ Mirror A |
| ⑩ Scanner motor | ㉒ Mirror B |
| ⑪ Tension pulley | ㉓ Mirror A |
| ⑫ Scanner gear 45/18 | ㉔ Scanner home position sensor |

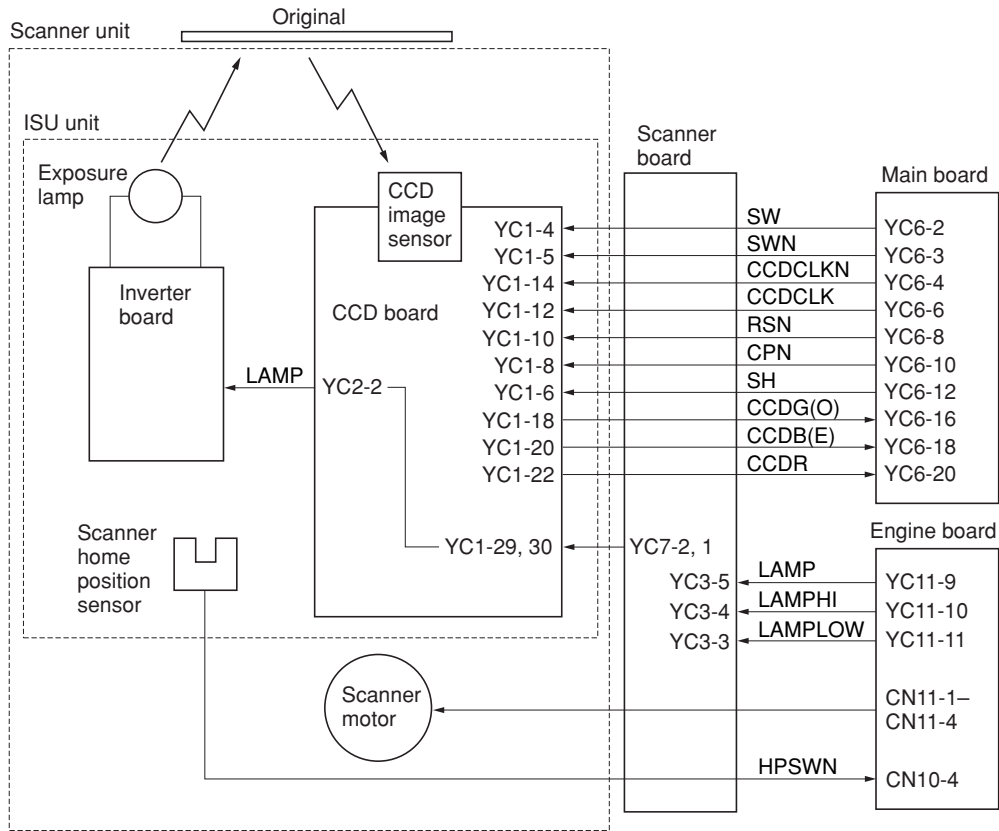

Figure 2-1-5 Scanner control circuit block diagram

(1) ISU unit

The ISU unit consists of an exposure lamp, three mirrors, an ISU lens, a CCD board, and so on. Also an inverter board for driving the exposure lamp and a scanner home position sensor for detecting the home position of the ISU unit are incorporated.

The original on the contact glass is exposed to the light of the exposure lamp that is reflected by the reflector. The image is input through reflection by the three mirrors and through the ISU lens to the CCD image sensor on the CCD board. The CCD image sensor scans one row of the image in the main scan direction, converts it to electric signals, and outputs them to the main board. Then the ISU unit is moved in the sub scan direction along the scanner shaft, and the CCD image sensor scans the next row of the image in the main scan direction. The operation described above is repeated for scanning the overall image of the original. If an optional DP is used, the ISU unit stops at the position of the DP contact glass and scans sequentially one row of the image on the original in synchronization with the moving timing of the original in the sub scan direction by driving the DP.

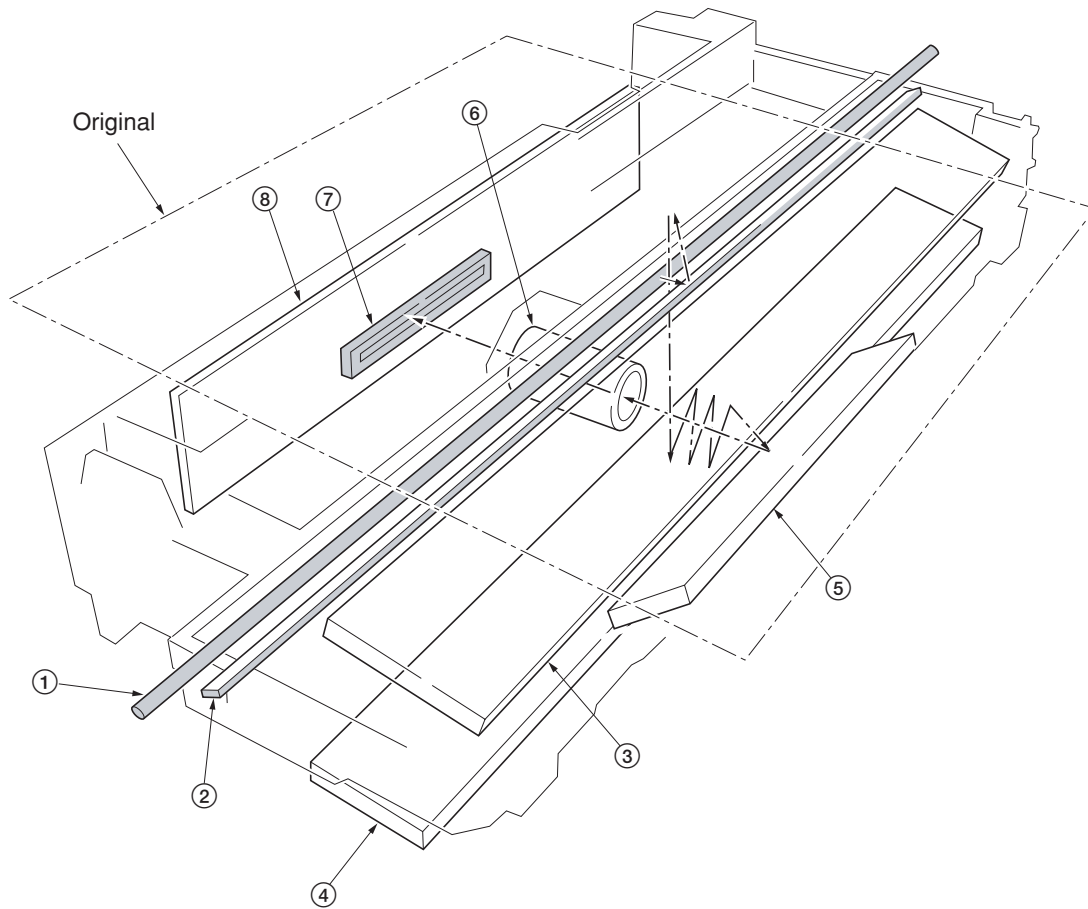

Figure 2-1-6 ISU unit

- ① Exposure lamp
- ② Scanner reflector
- ③ Mirror A
- ④ Mirror A
- ⑤ Mirror B
- ⑥ ISU lens
- ⑦ CCD image sensor
- ⑧ CCD board

2-1-3 Electrophotographic system

Electrophotography is the technology used in laser printing which transfer data representing texts or graphics objects into a visible image which is developed on the photosensitive drum, finally fusing on paper, using light beam generated by a laser diode.

This section provides technical details on the machine's electrophotography system.

(1) Electrophotographic cycle

The electrophotography system of the machine performs a cyclic action made of six steps as follows. Each step is technically explained in the following sections.

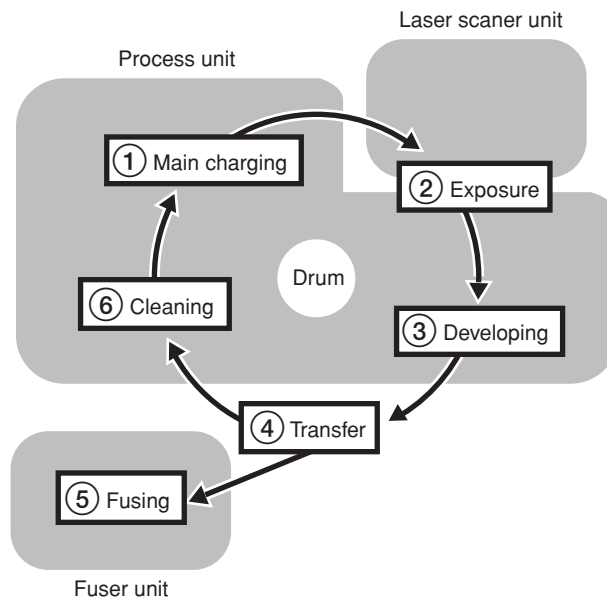
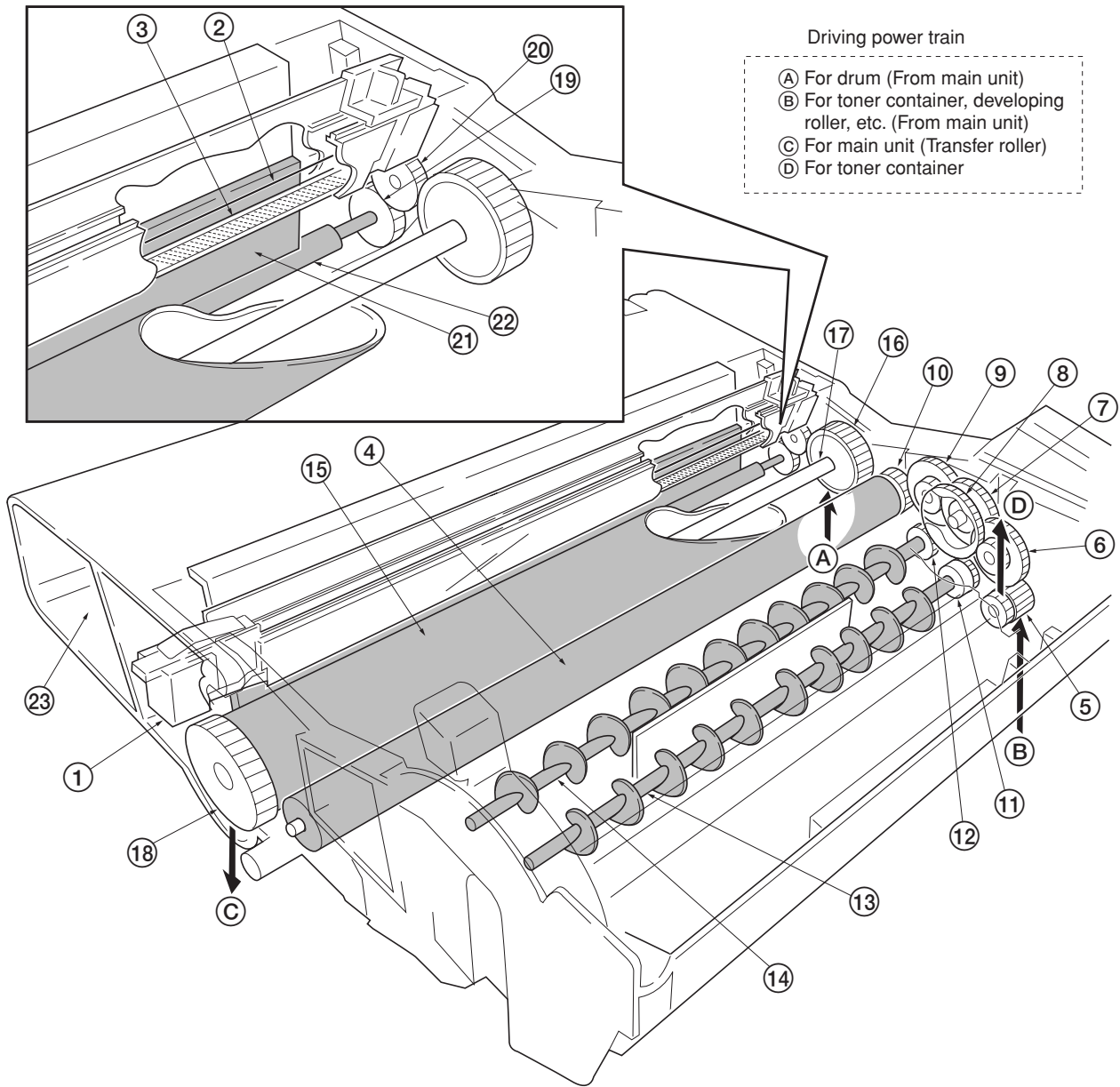

Figure 2-1-7 Electrophotographic cycle

The sections for main charging, exposure (drum), developing, and cleaning are modularized in one Process unit.

(1-1) Process unit mechanism



Driving power train

- (A) For drum (From main unit)
- (B) For toner container, developing roller, etc. (From main unit)
- (C) For main unit (Transfer roller)
- (D) For toner container

Figure 2-1-8 Process unit mechanism

- | | |
|---------------------|-------------------------|
| ① Main charger unit | ⑬ DLP screw B |
| ② Charger wire | ⑭ DLP screw A |
| ③ Grid | ⑮ Drum |
| ④ Developing roller | ⑯ Drum gear Z35H |
| ⑤ Gear Z14-Z18 | ⑰ Drum shaft |
| ⑥ Gear Z14-Z36 | ⑱ Drum gear Z36 |
| ⑦ Gear Z18-Z36 | ⑲ Sweep gear Z13 |
| ⑧ Free gear Z40 | ⑳ Idle gear 18H |
| ⑨ Gear Z18-Z35H | ㉑ Cleaning blade |
| ⑩ MAG gear Z24H | ㉒ Sweep roller |
| ⑪ Mixer gear Z20 B | ㉓ Waste toner reservoir |
| ⑫ Mixer gear Z20 A | |

(2) Main charging

(2-1) Photo conductive drum

The durable layer of organic photoconductor (OPC) is coated over the aluminum cylinder base. The OPC tend to reduce its own electrical conductance when exposed to light. After a cyclic process of charging, exposure, and development, the electrostatic image is constituted over the OPC layer.

Since the OPC is materialized by resin, it is susceptible to damage caused by sharp edges such as a screwdriver, etc., resulting in a print quality problem. Also, finger prints can cause deterioration of the OPC layer, therefore, the drum (in the process unit) must be handled with care. Substances like water, alcohol, organic solvent, etc., should be strictly avoided.

As with all other OPC drums, the exposure to a strong light source for a prolonged period can cause a print quality problem. The limit is approximately 500 lux for less than five minutes. If the drum (process unit) remains removed from the machine, it should be stored in a cool, dark place.

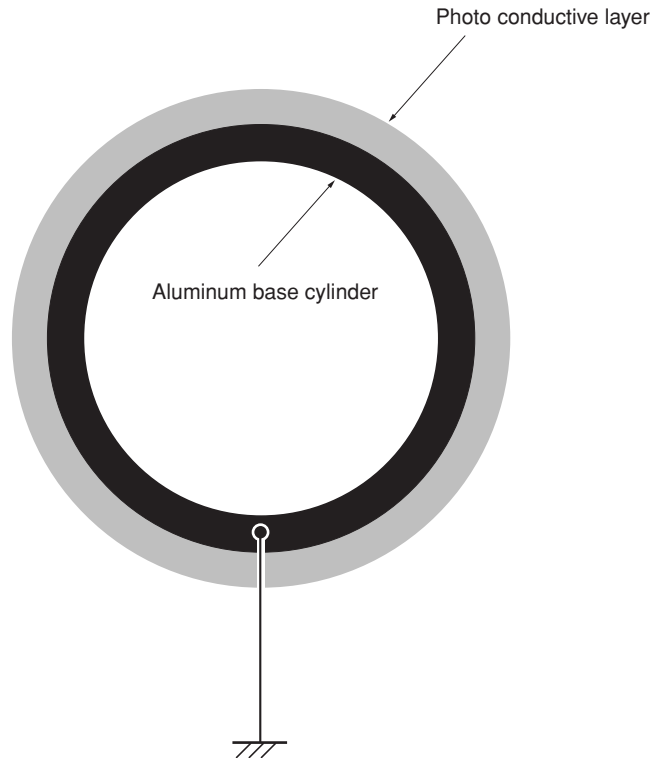

Figure 2-1-9 Photo conductive drum

(2-2) Charging the drum

The following shows a simplified diagram of the electrophotographic components in relation to the engine system. Charging the drum is done by the main charger unit (A).

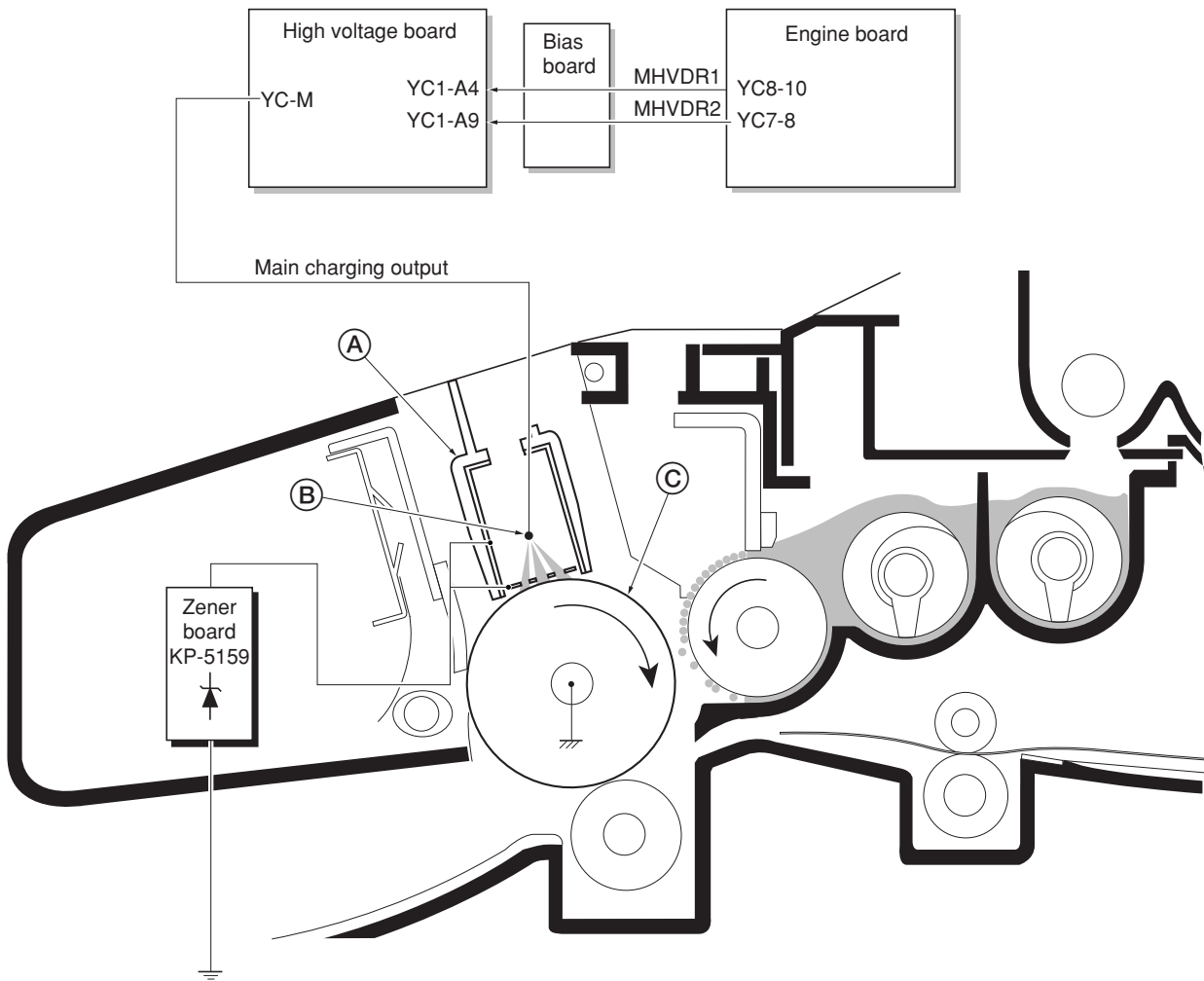

Figure 2-1-10 Charging the drum

As the drum (C) rotates in a “clean (neutral)” state, its photoconductive layer is given a uniform, positive (+) corona charge dispersed by the main charger wire (B).

Due to high-voltage scorotron charging, the charging wire can get contaminated by oxidization after a long run. Therefore, it must be cleaned periodically from time to time. Cleaning the charging wire prevents print quality problems such as black streaks.

(3) Exposure

The charged surface of the drum (A) is then scanned by the laser beam from the laser scanner unit (B).

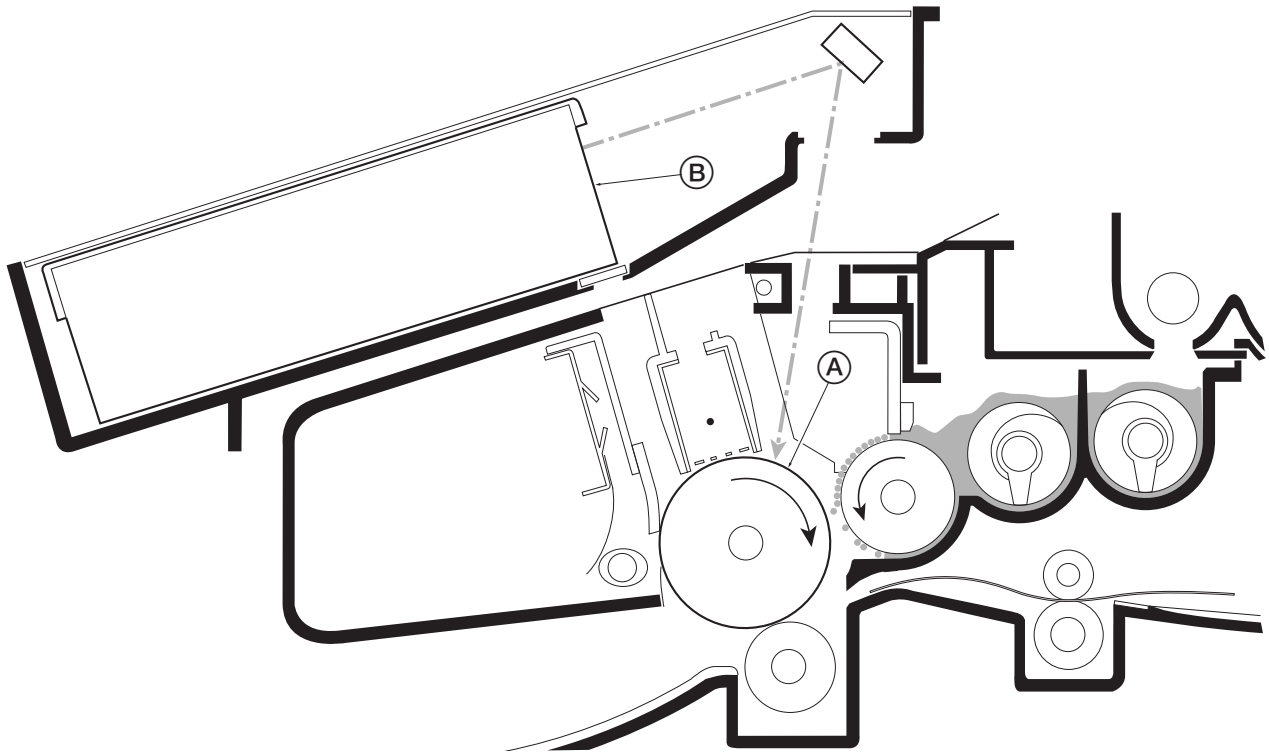

Figure 2-1-11 Exposure

The laser beam (780 nm wavelength) beam is dispersed as the polygon motor (polygon mirrors) revolves to reflect the laser beam over the drum. Various lenses and mirror are housed in the scanner unit, adjust the diameter of the laser beam, and focalize it at the drum surface.

(3-1) Laser scanner unit

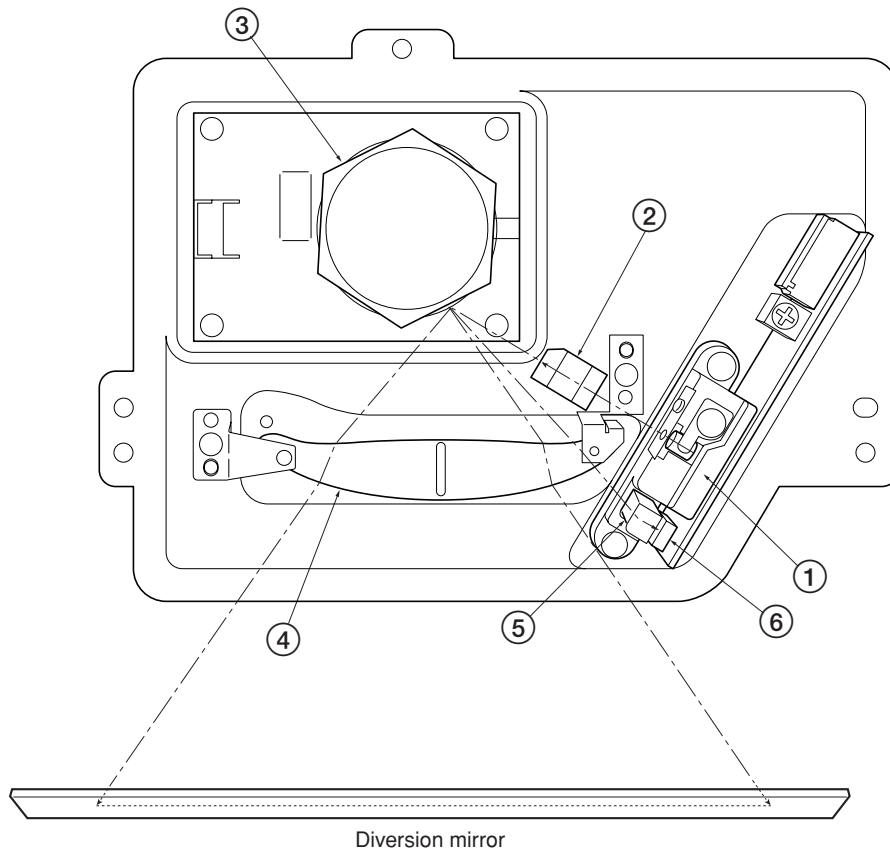

Figure 2-1-12 Laser scanner unit

- ① Laser diode Emits diffused, visible laser.
- ② Cylindrical lens Compensates the vertical angle at which the laser beam hits a polygon mirror segment.
- ③ Polygon mirror (motor) Has six mirror segments around its hexagonal circumference; each mirror corresponding to one scanned line width on the drum when laser beam scans on it.
- ④ F-theta lens The f-theta lens equalizes focusing distortion on the far ends of the drum.
- ⑤ Sensor mirror Bends the very first shot of a laser scan towards the beam detection sensor (⑥).
- ⑥ Pin photo sensor When shone by the sensor mirror above, this photo-sensor generates a trigger signal for the engine controller to start activating the paper feeding system.

(3-2) Drum surface potential

The laser beam is continually switched on and off depending on the print data. It is on for a black (exposed) dot and off for a white (blank) dot. Since the drum surface is evenly charged, whenever it is illuminated by the laser beam, the electrical resistance of the photoconductor is reduced and the potential on the photoconductor is also lowered. Resulted on the drum surface is an electrostatic image which represents the data to print. Note that the area to be printed black has the low potential, constituting a "positively exposed" image.

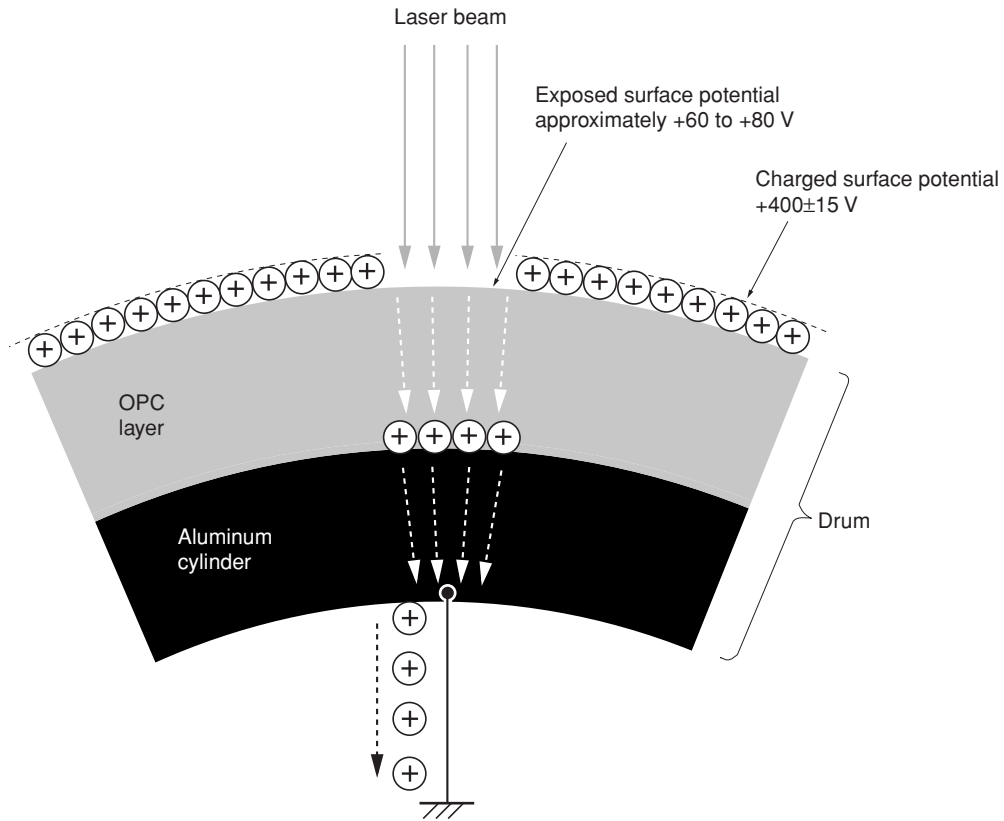

Figure 2-1-13 Drum surface potential

(4) Development

The latent image constituted on the drum is developed into a visible image. The developing roller (A) contains a 3-pole (S-N-S) magnet core (B) and an aluminum cylinder rotating around the magnet core (B). Toner attracts to the developing roller (A) since it is powdery ink made of black resin bound to iron particles. Doctor blade (C), magnetized by magnet (D), is positioned approximately 0.3 mm above the developing roller (A) to constitute a smooth layer of toner in accordance with the roller revolution.

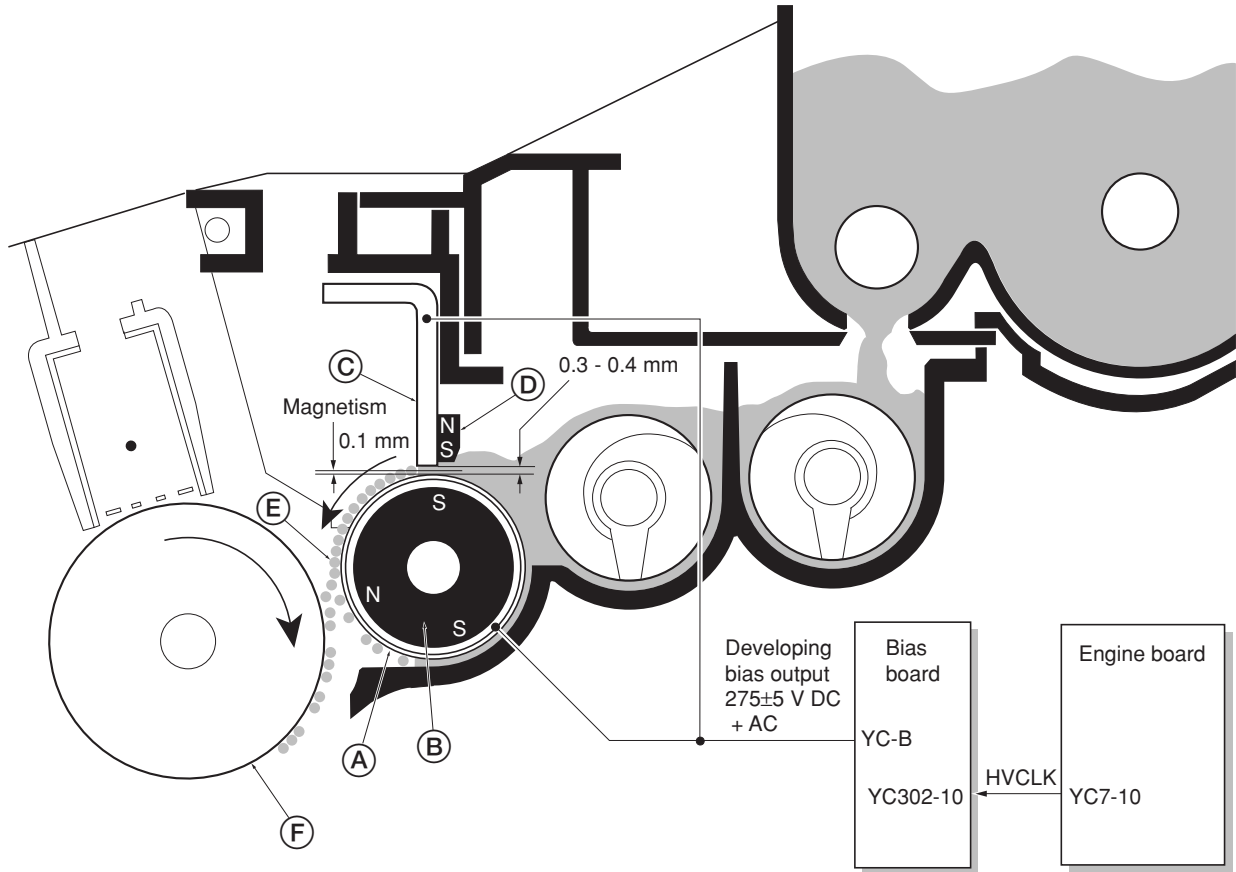

Figure 2-1-14 Development

The developing roller (A) is applied with the AC-weighted, positive DC power source. Toner (E) on the developing roller (A) is given a positive charge. The positively charged toner (E) is then attracted to the areas of the drum (F) which was exposed to the laser light. (The gap between the drum (F) and the developing roller (A) is approximately 0.3 mm.) The non-exposed areas of the drum (F) repel the positively charged toner as these areas maintain the positive charge. The developing roller (A) is also AC-biased to ensure contrast in yielding by compensating the toner's attraction and repelling action during development.

(5) Transfer

The image developed by toner on the drum (A) is transferred onto the paper because of the electrical attraction between the toner itself and the transfer roller (B). The transfer roller is negatively biased so that the positively charged toner is attracted onto the paper while it is pinched by the drum and the transfer roller.

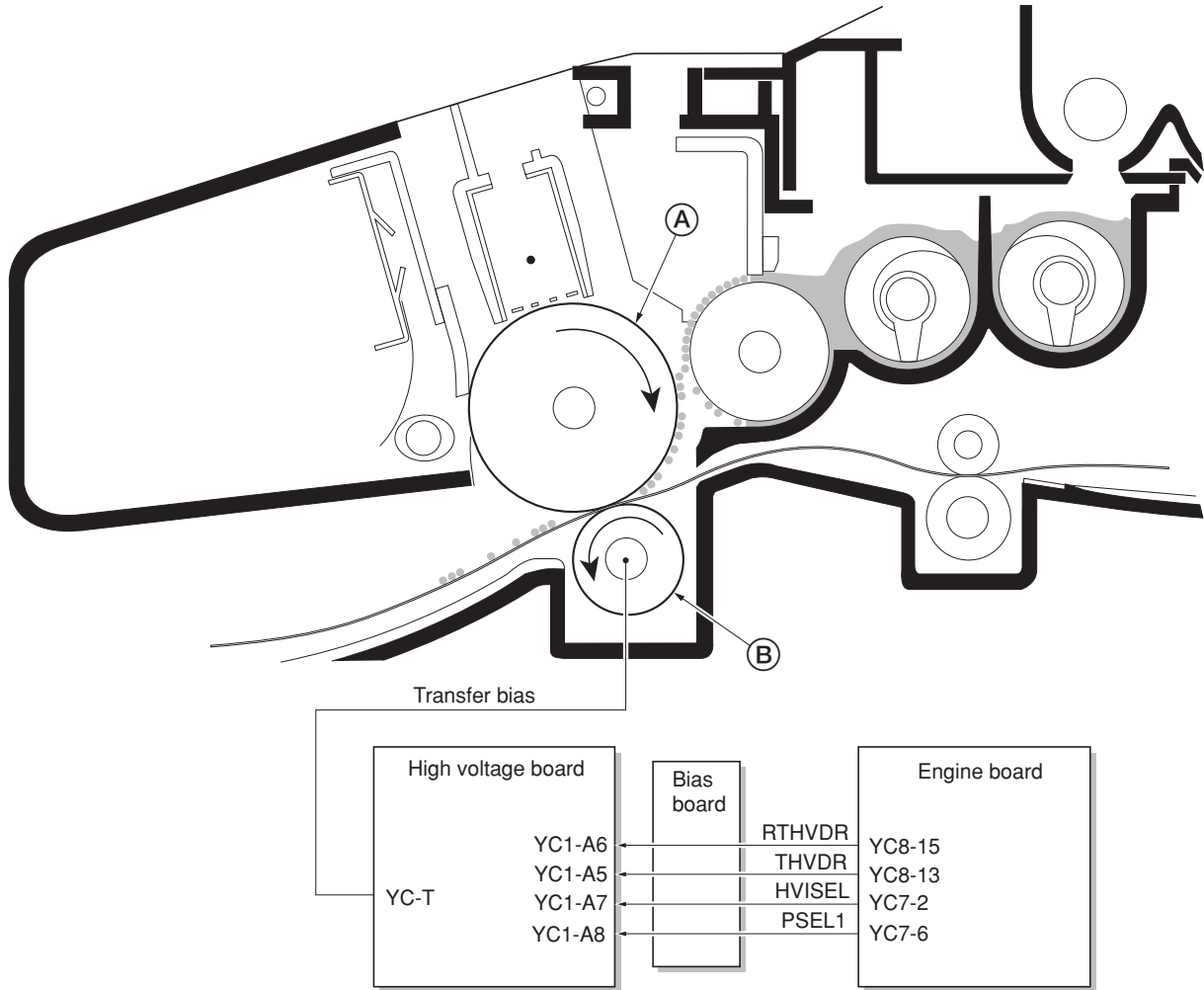

Figure 2-1-15 Transfer

The nominal transfer bias is set to approximately -1.8 kV (limit) with the -6 mA current. Since the ideal potential of the transfer bias depends on the thickness of paper, the bias is raised to approximately -2.5 kV/-6 mA for thicker paper. On the other hand, the bias current is reduced to -1.8 kV/-6 mA for thin paper.

(6) Fusing

The toner on the paper is molten and pressed into the paper as it passes between the heat roller (A) and the press roller (B) in the fuser unit.

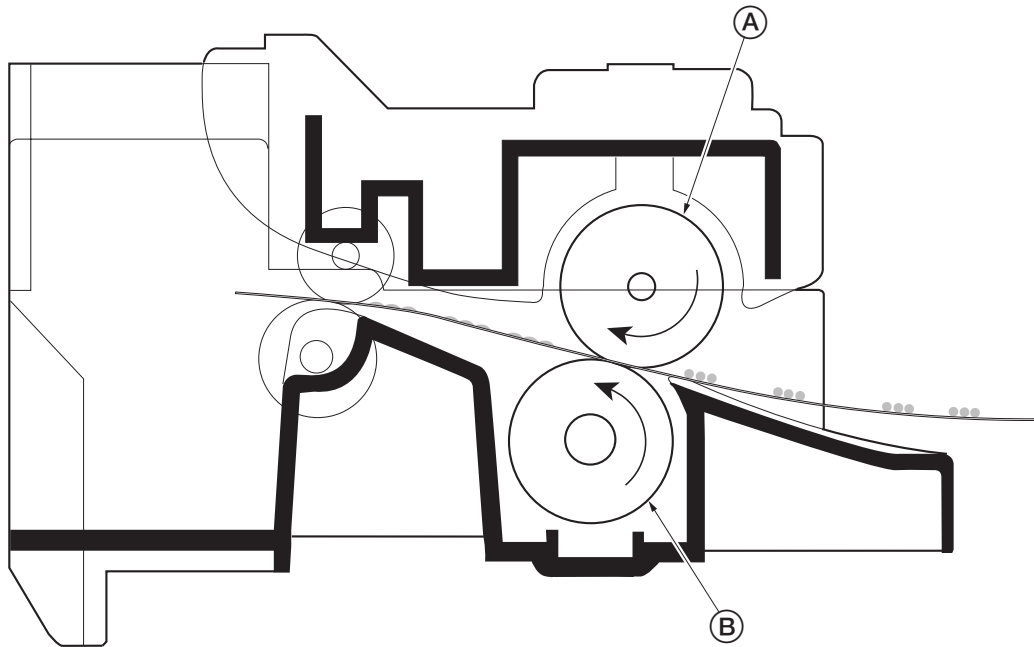

Figure 2-1-16 Fusing

The heat roller has a halogen lamp inside which continuously turns on and off by the thermistor to maintain the constant temperature onto the heat roller surface.

The heat roller is resin coated by fluorin to prevent toner from accumulating on the roller after a long run. Care must be taken while handling the heat roller not to scratch the roller surface as doing so may result in print problems.

The heat roller has four claws which are continuously in contact with its surface. These claws prevent the paper on which toner has been fused from being wound around the heat roller causing paper jam.

The pressure roller is made of the heat-resistant silicon rubber. This roller is used to strongly press the paper towards the heat roller by means of coil springs.

The temperature of the heat roller is constantly monitored by the engine board using the thermistor and triac. Should the temperature of the heat roller exceed the predetermined value, the thermal cutout is activated to effectively disconnect the heater (halogen) lamp from power.

(6-1) Fuser unit mechanism

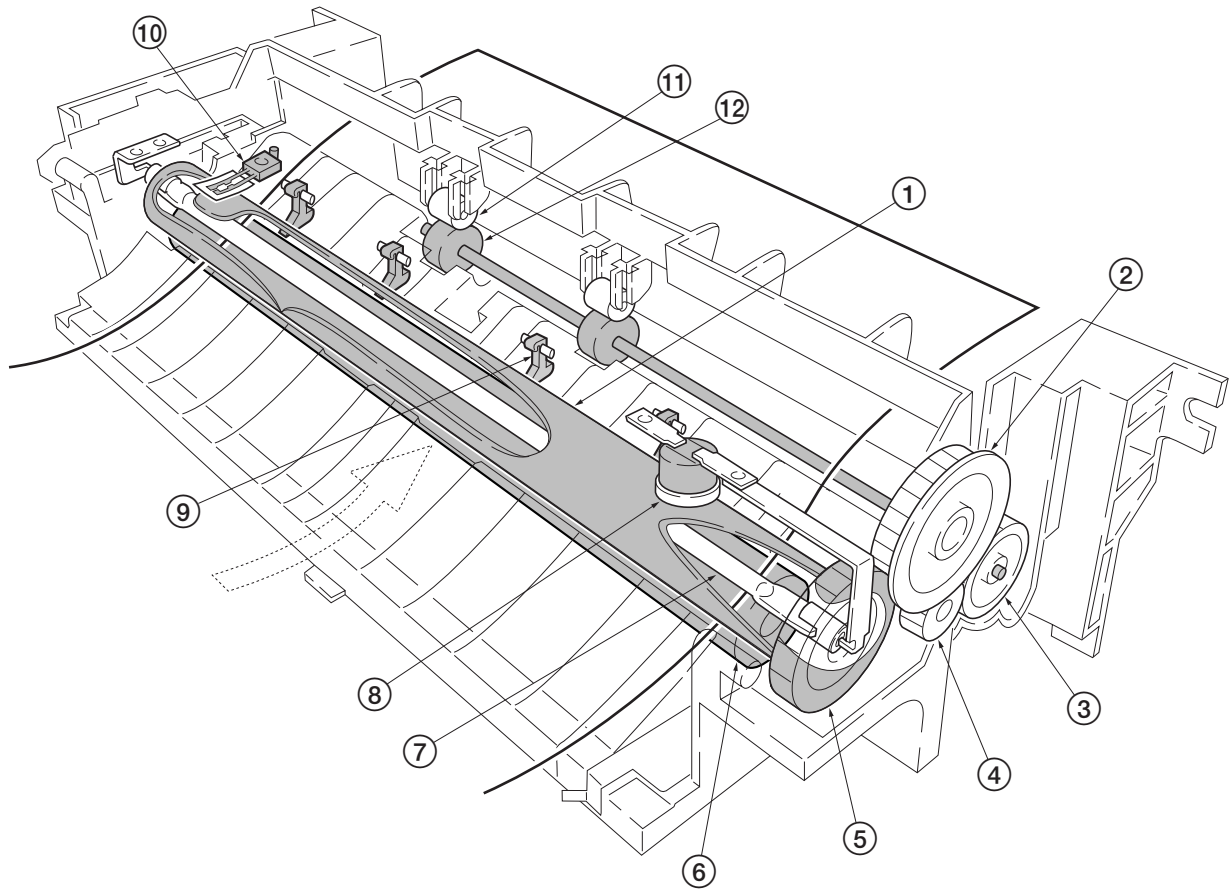

Figure 2-1-17 Fuser unit mechanism

- | | |
|-----------------|---------------------|
| ① Heat roller | ⑦ Heater lamp |
| ② Idle gear Z34 | ⑧ Thermal cutout |
| ③ Exit gear Z23 | ⑨ Separator(s) |
| ④ Idle gear Z18 | ⑩ Thermistor |
| ⑤ Heat gear Z33 | ⑪ Exit pulley(s) |
| ⑥ Press roller | ⑫ Lower exit roller |

(7) Cleaning

After the transferring process, the drum needs to be physically cleaned of toner which is residual after the development process. The cleaning blade (A) is constantly pressed against the drum (B) and scrapes the residual toner off to the sweep roller (C). The waste toner is collected at the output end of the sweep roller (C) and sent back to the toner container, into the waste toner reservoir (D).

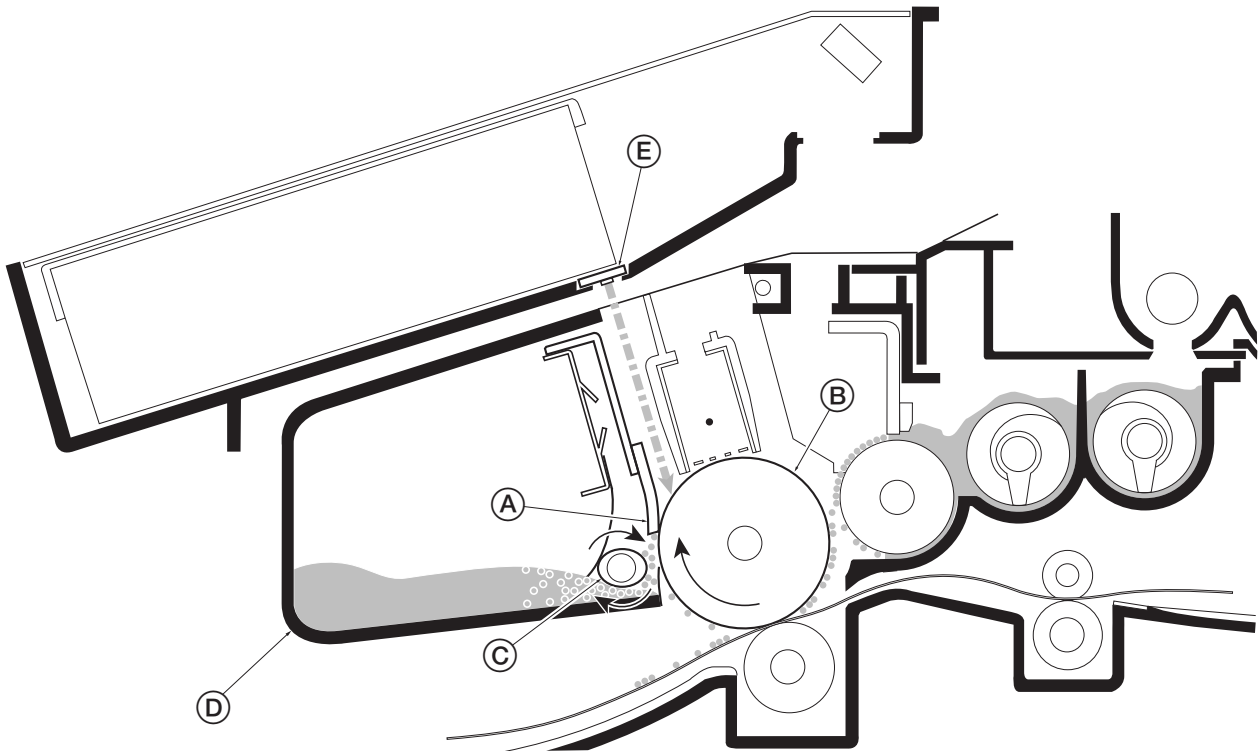

Figure 2-1-18 Drum cleaning and erasing static charge

After the drum (B) is physically cleaned, it then must be cleaned to the electrically neutral state. This is necessary to erase any residual positive charge, ready to accept the uniform charge for the next print process. The residual charge is canceled by exposing the drum (B) to the light emitted from the eraser lamp (E). This lowers the electrical conductivity of the drum surface making the residual charge on the drum surface escape to the ground.

2-2-1 Electrical parts layout

(1) Main unit

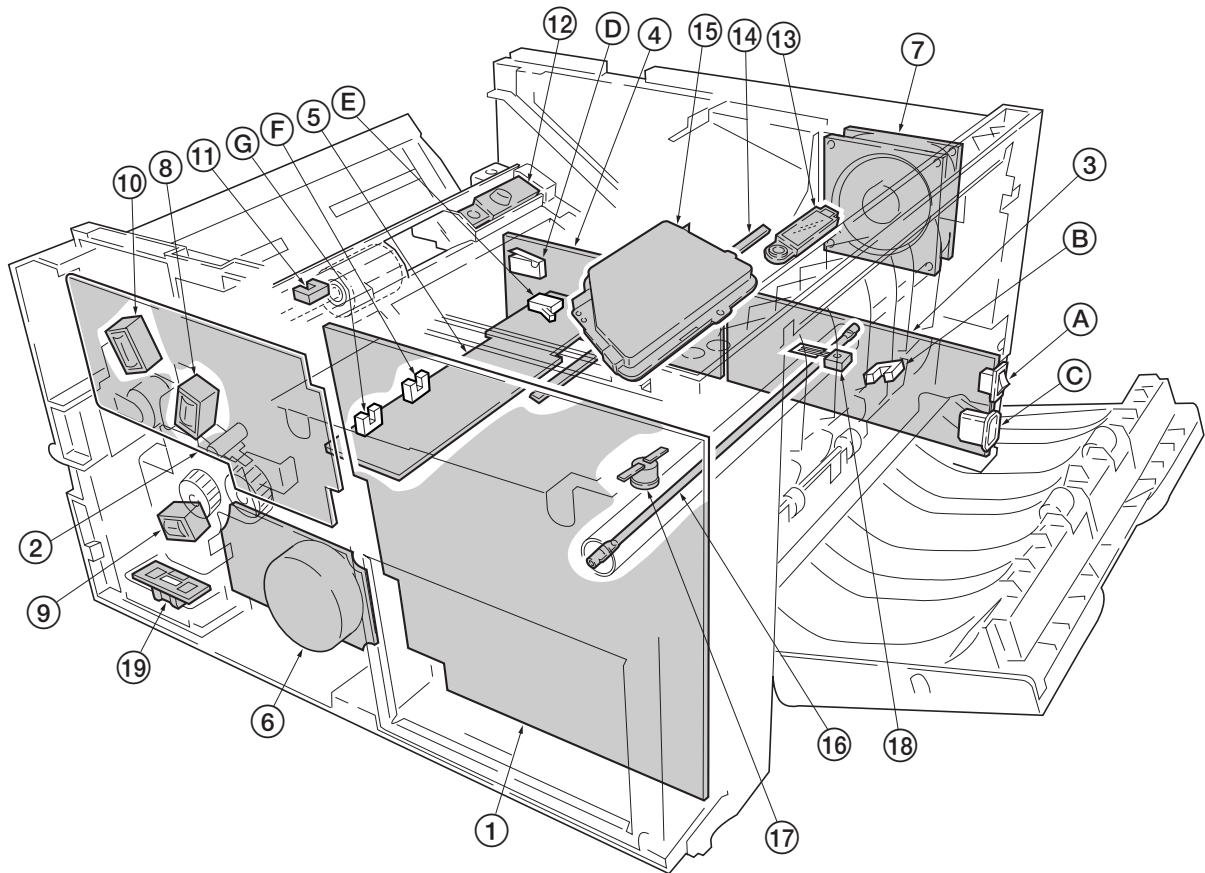

Figure 2-2-2 Main unit

- | | |
|--------------------------|--------------------------------------|
| ① Main board (KP-5191) | ⑦ Cooling fan |
| ② Engine board (KP-5238) | ⑧ Registration clutch |
| ③ Power supply board | ⑨ Feed clutch |
| A Power switch | ⑩ MP feed clutch |
| B Exit sensor | ⑪ MP paper sensor |
| C AC Inlet | ⑫ Toner sensor [PWB] (KP-5155) |
| ④ High voltage board | ⑬ Waste toner sensor [PWB] (KP-5155) |
| D Interlock switch | ⑭ Eraser lamp [PWB] (KP-5157) |
| ⑤ Bias board (KP-5242) | ⑮ Laser scanner unit |
| E Cassette switch | ⑯ Heater lamp |
| F Registration sensor | ⑰ Thermal cutout |
| G Paper sensor | ⑱ Thermistor |
| ⑥ Main motor | ⑲ Paper feeder interface connector |

(2) Scanner unit

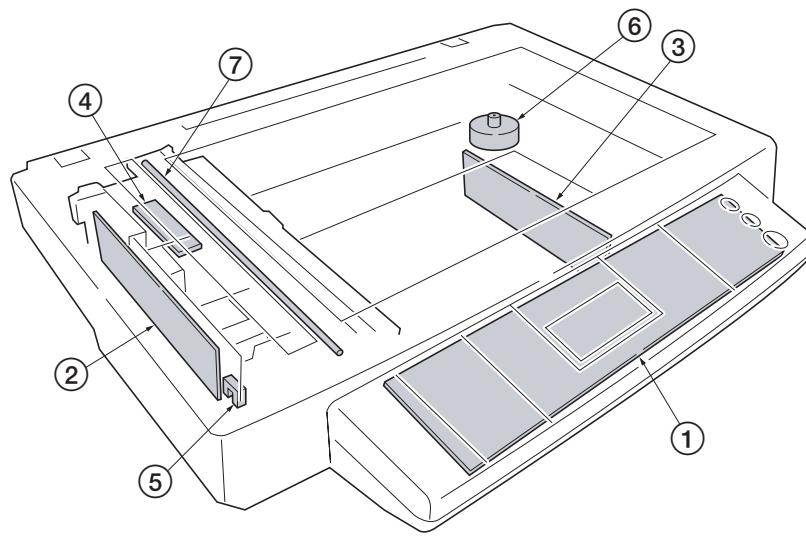

Figure 2-2-2 Scanner unit

- ① Operation board
- ② CCD board (KP-5252)
- ③ Scanner board (KP-5063)
- ④ Inverter board
- ⑤ Scanner home position sensor
- ⑥ Scanner motor
- ⑦ Exposure lamp

2-3-1 Main board

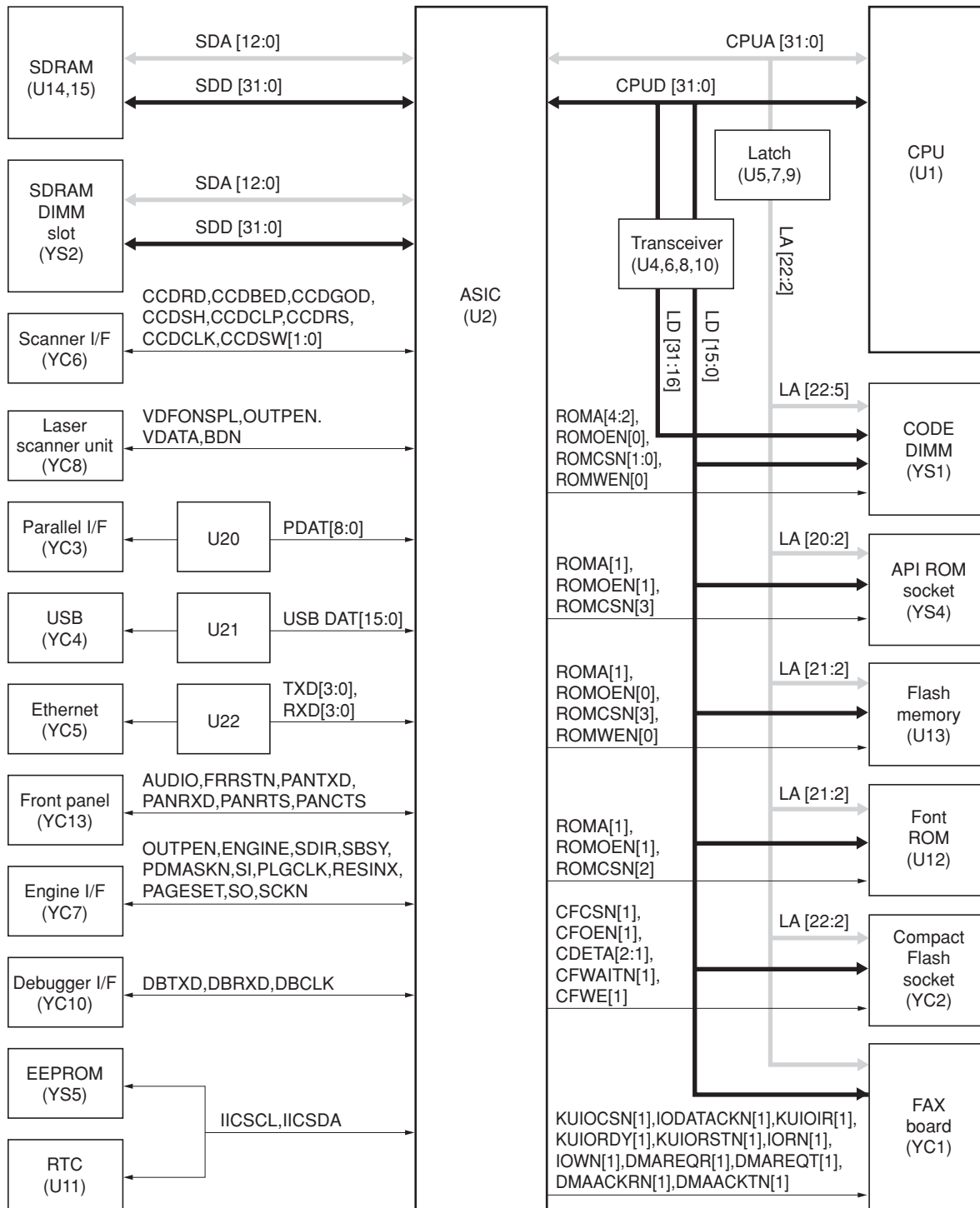

Figure 2-3-1 Main board circuit block diagram

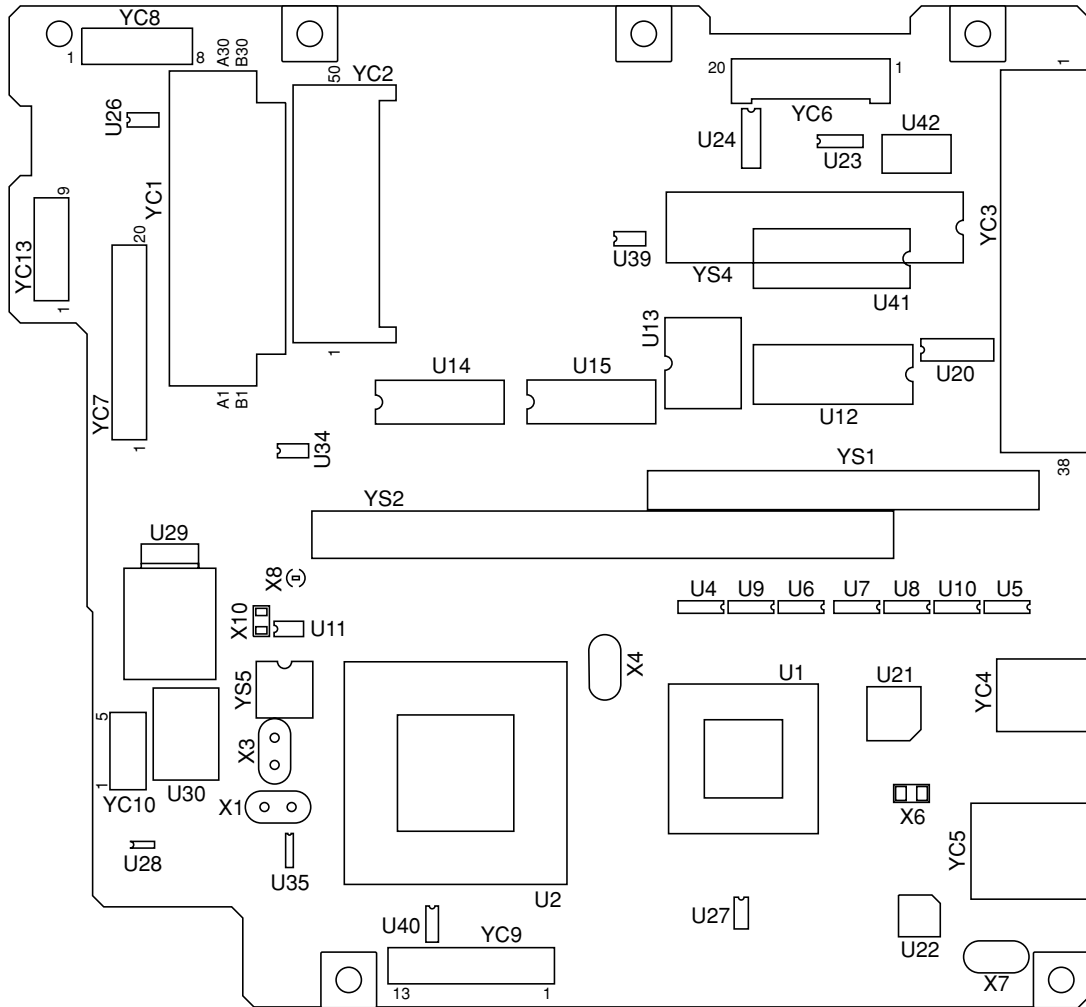

Figure 2-3-2 Main board silk-screen diagram

Connector	Pin No.	Signal	I/O	Description
YC1	A1	NC	-	Not used
Connected to the FAX board	A2	NC	-	Not used
	A3	AUDIO	I	AUDIO signal
	A4	+3.3 V	O	3.3 V DC power supply
	A5	GND	-	Ground
	A6	A13	O	Address bus A13
	A7	A11	O	Address bus A11
	A8	A9	O	Address bus A9
	A9	GND	-	Ground
	A10	A6	O	Address bus A6
	A11	A4	O	Address bus A4
	A12	A2	O	Address bus A2
	A13	GND	-	Ground
	A14	OP2IFn	O	OP2IF signal
	A15	OP2IRn	I	OP2IR signal
	A16	RDY	O	Ready signal
	A17	GND	-	Ground
	A18	IORn	O	IOR signal
	A19	RESETn	O	Reset signal
	A20	D15	O	Data bus D15
	A21	GND	-	Ground
	A22	D12	O	Data bus D12
	A23	D10	O	Data bus D10
	A24	D8	O	Data bus D8
	A25	GND	-	Ground
	A26	D5	O	Data bus D5
	A27	D3	O	Data bus D3
	A28	D1	O	Data bus D1
	A29	GND	-	Ground
	A30	NC	-	Not used
	B1	NC	-	Not used
B2	TXDREQ	I	TXDREQ signal	
B3	+3.3 V	O	3.3 V DC power supply	
B4	A15	O	Address bus A15	
B5	A14	O	Address bus A14	
B6	A12	O	Address bus A12	
B7	A10	O	Address bus A10	
B8	A8	O	Address bus A8	
B9	A7	O	Address bus A7	
B10	A5	O	Address bus A5	
B11	A3	O	Address bus A3	
B12	A1	O	Address bus A1	
B13	+3.3 V	O	3.3 V DC power supply	
B14	OP2ACKn	I	OP2ACK signal	
B15	+5 V	O	5 V DC power supply	
B16	RXDREQ	I	RXDREQ signal	
B17	RXDMACKn	O	RXDMACK signal	
B18	IOWn	O	IOW signal	
B19	TXDMACKn	O	TXDMACK signal	
B20	D14	O	Data bus D14	
B21	D13	O	Data bus D13	
B22	D11	O	Data bus D11	
B23	D9	O	Data bus D9	
B24	D7	O	Data bus D7	
B25	D6	O	Data bus D6	
B26	D4	O	Data bus D4	
B27	D2	O	Data bus D2	
B28	D0	O	Data bus D0	
B29	NC	-	Not used	
B30	NC	-	Not used	

Connector	Pin No.	Signal	I/O	Description
YC2	1	GND	-	Ground
Connected to the compact flash socket	2	D3	O	Data bus D3
	3	D4	O	Data bus D4
	4	D5	O	Data bus D5
	5	D6	O	Data bus D6
	6	D7	O	Data bus D7
	7	CE1n	O	CE1 signal
	8	A10	O	Address bus A10
	9	OEn	O	OE signal
	10	A9	O	Address bus A9
	11	A8	O	Address bus A8
	12	A7	O	Address bus A7
	13	VCC	O	3.3 V DC power supply
	14	A6	O	Address bus A6
	15	A5	O	Address bus A5
	16	A4	O	Address bus A4
	17	A3	O	Address bus A3
	18	A2	O	Address bus A2
	19	A1	O	Address bus A1
	20	A0	O	Address bus A0
	21	D0	O	Data bus D0
	22	D1	O	Data bus D1
	23	D2	O	Data bus D2
	24	WP	-	Not used
	25	CD2n	I	CD2 signal
	26	CD1n	I	CD1 signal
	27	D11	O	Data bus D11
	28	D12	O	Data bus D12
	29	D13	O	Data bus D13
	30	D14	O	Data bus D14
	31	D15	O	Data bus D15
32	CE2n	O	CE2 signal	
33	VS1n	O	VS1 signal	
34	IORDn	O	IORD signal	
35	IOWRn	O	IOWR signal	
36	WEn	O	WE signal	
37	RDY/BSYn	-	Not used	
38	VCC	O	3.3 V DC power supply	
39	CSELn	O	CSEL signal	
40	VS2n	-	Not used	
41	RESET	O	Reset signal	
42	WAITn	I	WAIT signal	
43	INPACKn	-	Not used	
44	REGn	O	REG signal	
45	BVD2n	-	Not used	
46	BVD1n	-	Not used	
47	D8	O	Data bus D8	
48	D9	O	Data bus D9	
49	D10	O	Data bus D10	
50	GND	-	Ground	
YC3	1	STB	I	STB signal
Connected to the parallel I/F	2	DATA1	I	DATA1 signal
	3	DATA2	I	DATA2 signal
	4	DATA3	I	DATA3 signal
	5	DATA4	I	DATA4 signal
	6	DATA5	I	DATA5 signal
	7	DATA6	I	DATA6 signal
	8	DATA7	I	DATA7 signal
	9	DATA8	I	DATA8 signal
	10	ACK	O	ACK signal
	11	BUSY	O	BUSY signal

Connector	Pin No.	Signal	I/O	Description
YC3 Connected to the parallel I/F	12	PE	O	Paper empty signal
	13	SEL	O	Select signal
	14	CAN	I	CAN signal
	15	RMR	-	Not used
	16	SG	-	Ground
	17	FG	-	Ground
	18	INIT	O	5 V DC power supply
	19	GND	-	Ground
	20	GND	-	Ground
	21	GND	-	Ground
	22	GND	-	Ground
	23	GND	-	Ground
	24	GND	-	Ground
	25	GND	-	Ground
	26	GND	-	Ground
	27	GND	-	Ground
	28	GND	-	Ground
	29	GND	-	Ground
	30	ARARM	-	Ground
	31	ASFON	-	Not used
	32	FAULT	O	FAULT signal
	33	HSTI	-	Not used
	34	EXPRM	-	Not used
	35	PRDY	O	Power ready signal
36	SELI	-	Not used	
YC4 Connected to the USB	1	VBUS	I	VBUS signal
	2	DATA-	O	DATA- signal
	3	DATA+	O	DATA+ signal
	4	GND	-	Ground
YC5 Connected to the Ethernet	1	TXOP	O	TXOP signal
	2	+3.3 V	O	3.3 V DC power supply
	3	TXON	O	TXON signal
	4	RXIP	I	RXIP signal
	5	+3.3 V	O	3.3 V DC power supply
	6	RXIN	I	RXIN signal
	7	NC	-	Not used
	8	GND	-	Ground
	9	+3.3 V	O	3.3 V DC power supply
	10	/LEDL	I	LEDL signal
	11	+3.3 V	O	3.3 V DC power supply
	12	LEDN	I	LEDN signal
YC6 Connected to the scanner board	1	SHRGB	O	RGB shift signal
	2	SW	O	Color/monochro control signal
	3	SWN	O	Color/monochro control signal
	4	CCDCLKN	O	CCD clock signal
	5	GND	-	Ground
	6	CCDCLK	O	CCD clock signal
	7	GND	-	Ground
	8	RSN	O	CCD RS signal
	9	GND	-	Ground
	10	CPN	O	CCD CP signal
	11	GND	-	Ground
	12	SH	O	CCD shift signal
	13	GND	-	Ground
	14	GND	-	Ground
	15	GND	-	Ground
	16	CCDG(O)	I	Image data G (green) signal (analog)
	17	GND	-	Ground
	18	CCDB(E)	I	Image data B (blue) signal (analog)

Connector	Pin No.	Signal	I/O	Description
YC6	19	GND	-	Ground
Connected to the scanner board	20	CCDR	I	Image data R (red) signal (analog)
YC7	1	SGND	-	Ground
Connected to the engine board	2	SGND	-	Ground
	3	+3.3 V	I	3.3 V DC power supply
	4	+3.3 V	I	3.3 V DC power supply
	5	+5 V	I	5 V DC power supply
	6	OUTPEN	I	OUTPEN signal
	7	SGND	-	Ground
	8	PLGCLK	O	PLGCLK signal
	9	EGSO	I	EGSO signal
	10	SCKN	O	SCKN signal
	11	EGSI	O	EGSI signal
	12	PDMASKN	I	PDMASKN signal
	13	SBSY	I	SBSY signal
	14	SDIR	I	SDIR signal
	15	EGRN	I	EGRN signal
	16	SGND	-	Ground
	17	RSTN	I	RSTN signal
	18	SGND	-	Ground
	19	OVSYNC	I	OVSYNC signal
	20	SGND	-	Ground
YC8	1	SGND	-	Ground
Connected to the laser scanner unit	2	SAMPLEN	O	SAMPLEN signal
	3	VDATA	O	VDATA signal
	4	OUTPEN	O	OUTPEN signal
	5	SGND	-	Ground
	6	+5 V	O	5 V DC power supply
	7	SGND	-	Ground
	8	PDN	I	Horizontal synchronization signal
YC10	1	+5 V	O	5 V DC power supply
Connected to the debugger I/F	2	DBTXD	O	DBTXD signal
	3	DBRXD	I	DBRXD signal
	4	DBCLK	I	DBCLK signal
	5	GND	-	Ground
YC13	1	SGND	-	Ground
Connected to the scanner board	2	AUDIO	O	AUDIO signal
	3	+5 V	O	5 V DC power supply
	4	FPRSTN	O	FPRSTN signal
	5	PANTXD	O	PANTXD signal
	6	PANRXD	I	PANRXD signal
	7	PANRTS	O	PANRTS signal
	8	PANCTS	I	PANCTS signal
	9	+3.3 V	O	3.3 V DC power supply

2-3-2 Engine board

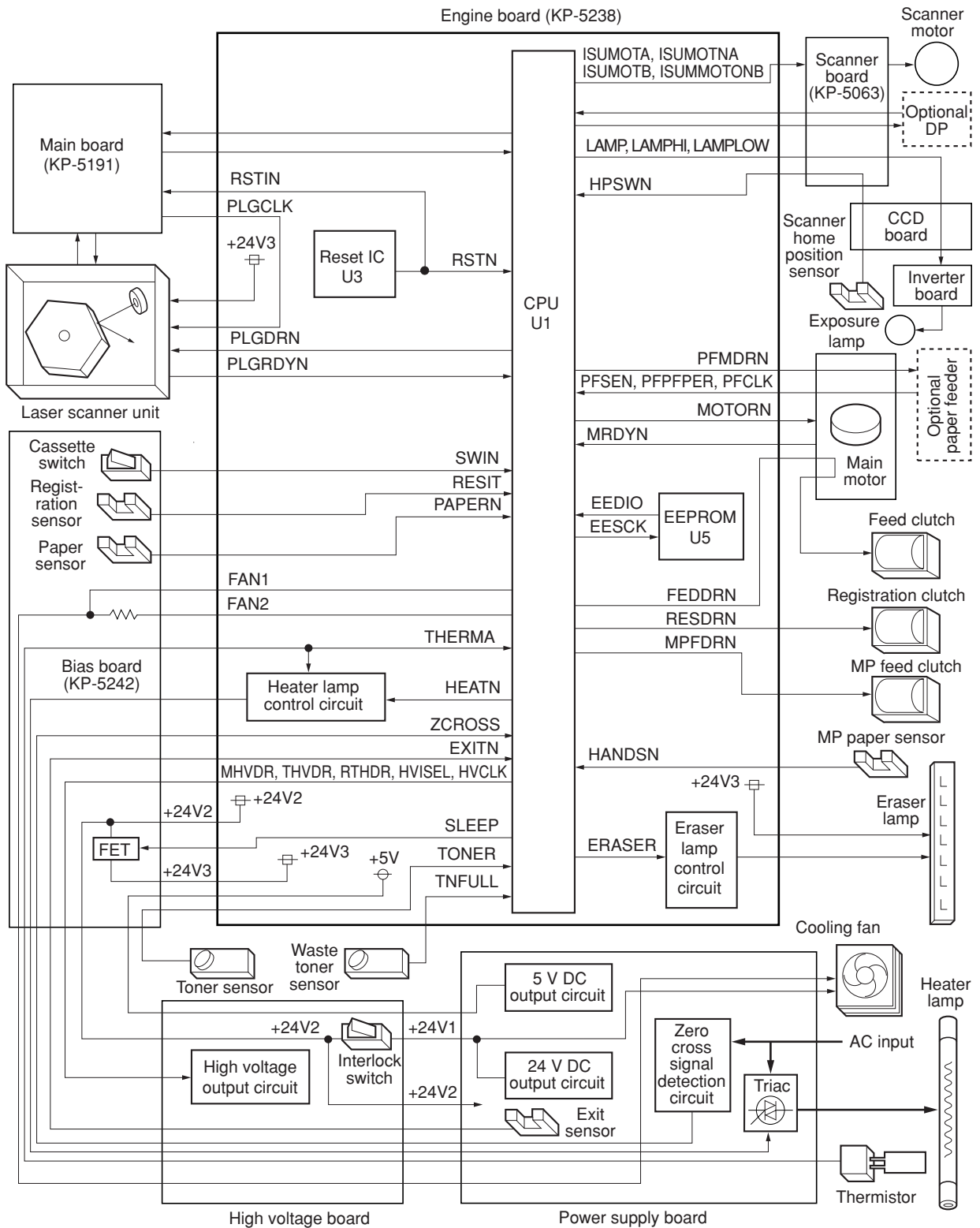

Figure 2-3-3 Engine board circuit block diagram

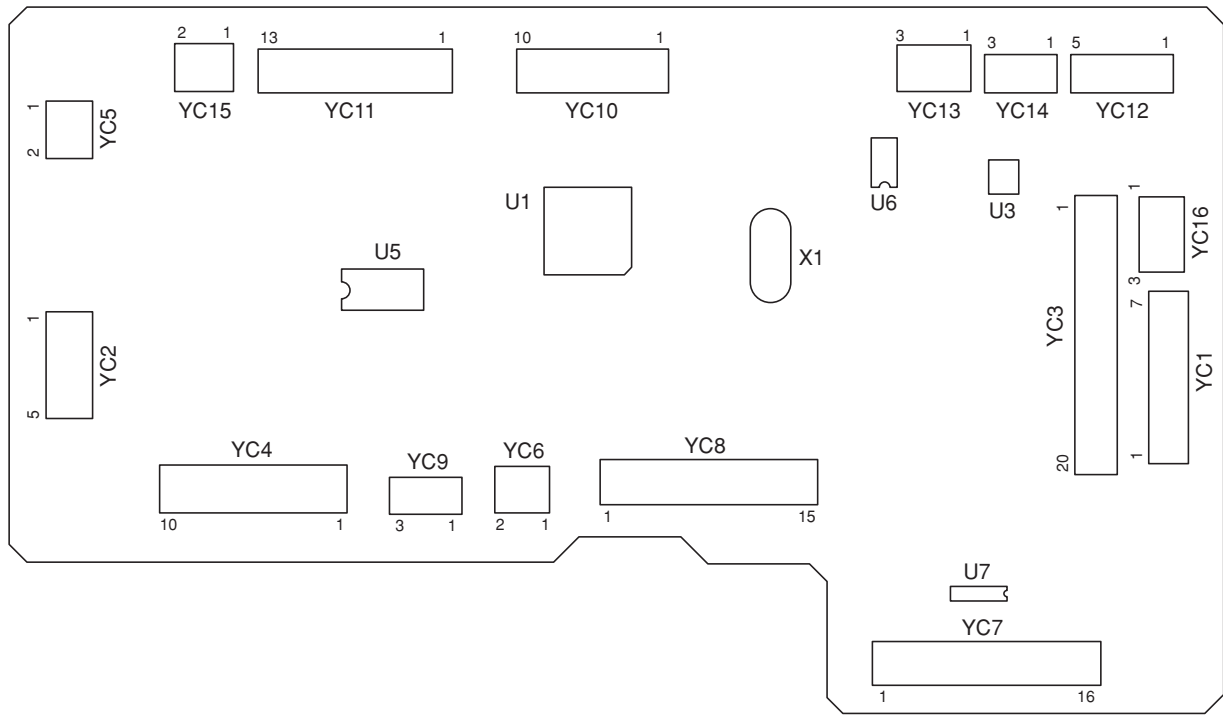

Figure 2-3-4 Engine board silk-screen diagram

(1) Eraser lamp control circuit

The CPU (U1) turns pin #86 (ERASER) of U1 to H level, transistors (Q18) turns on consequently, and the 24 V DC given at pin #1 of connector YC14 applies to the eraser lamps. The eraser lamps thus illuminate as the current flows through the eraser lamp, the pin #2 of connector YC14, resistors (R109, R110, and R111), transistor Q18 and the ground.

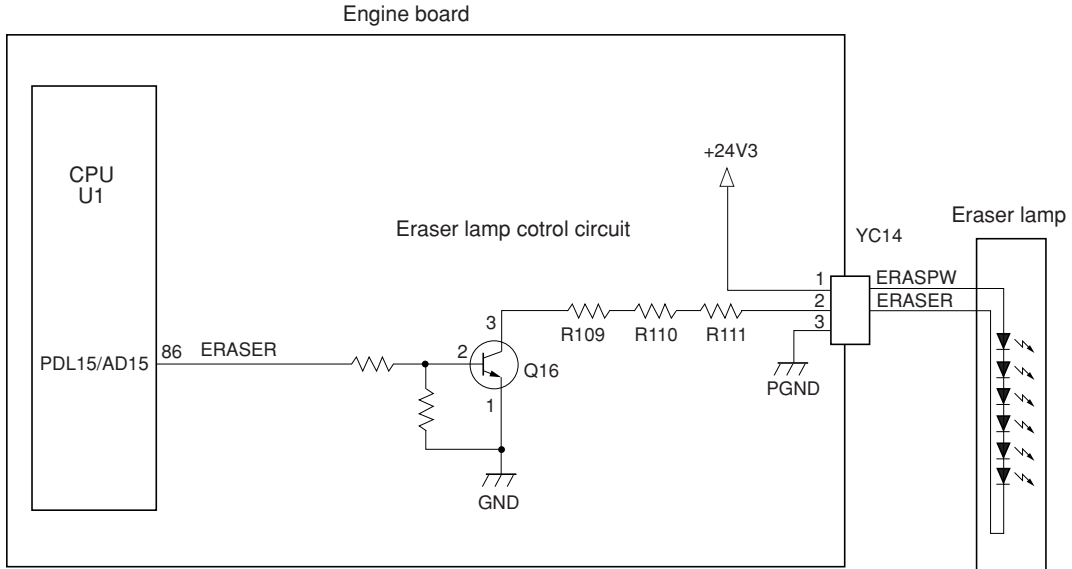

Figure 2-3-5 Eraser lamp control circuit

(2) Heater lamp control circuit

Activation of the heater lamp is dominated by the HEAT signal which is derived by the engine CPU (U1) at its pin #74. When its level is high, transistor Q8 turns on, photo-triac PC2 and triac TRC1 turn on simultaneously, and the heater lamp is applied with the primary AC voltage in turn.

Switching of triac TRC1, as affected by the HEAT signal is made in synchronization with the zero-cross signal ZCROSS which is generated by the power supply unit. The zero-cross signal detector watches the transition of alternating plus and negative current and detects the zero crosses. This detector derives the resultant ZCROSS signal at its pin #20 of the engine CPU (U1). Since abrupt change in the current flow can be significantly avoided by synchronizing triac TRC1 with the zero-cross signal, the possibility of noise due to the primary AC supply is greatly reduced.

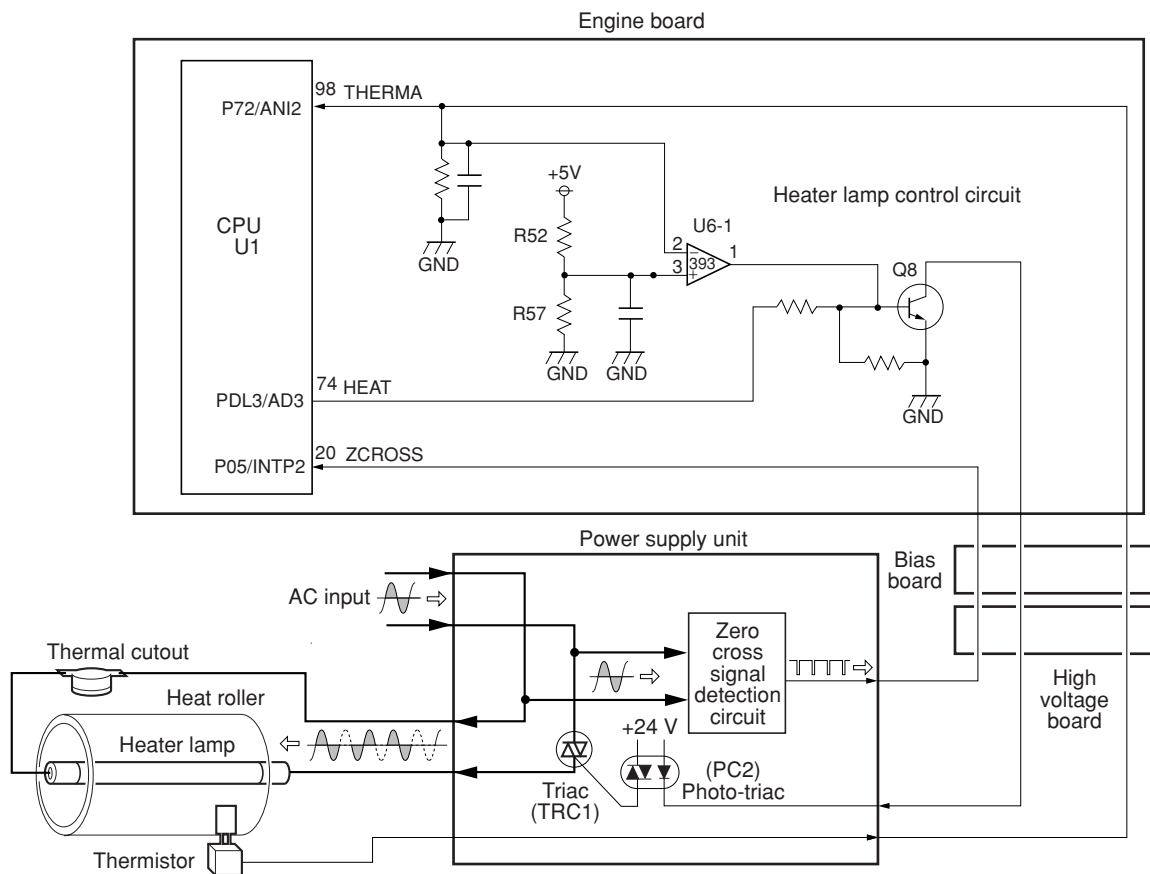

Figure 2-3-6 Heater lamp control circuit

The AC power for the heater is applied in one of the five variations of the zero cross switchings as shown in Figure 2-3-7. Each variation is constituted with the unit of ten positive and negative envelopes in five cycles, as obtained by varying the duration during which TRC1 turns on. The heater lamp is energized while TRC1 is kept on; the heater lamp is turned off while TRC1 is kept off. For example, the duty cycle (the period of a cycle during which the heater lamp is turned on) is maximum for variation No.1 as the heater lamp is energized for the whole envelopes. The duty cycle is 60 % for variation No.3 as the heater lamp is energized for the 6 positive and negative envelopes out of 10. The duty cycle is 0 since the heater lamp is kept turned off for the whole envelopes.

CPU (U1) selectively switches among those variations for applying voltages to the heater lamp according to the THERMA signal which appears at pin #98 as feedback.

A fraction of THERMA is applied to pin #2 of comparator U6-1. The comparator maintains comparison of the potential at pin #2 and pin #3 which gives a reference for the possible anomaly in the heater temperature (bred by resistors R52 and R57). Should the voltage at pin #2 exceed that at pin #98, the level at pin #1 becomes low. Since pin #1 is wired to the output line for the HEAT signal, the HEAT signal is enforced to be low regardless the behavior of CPU (U1), thus preventing possible heat overrun.

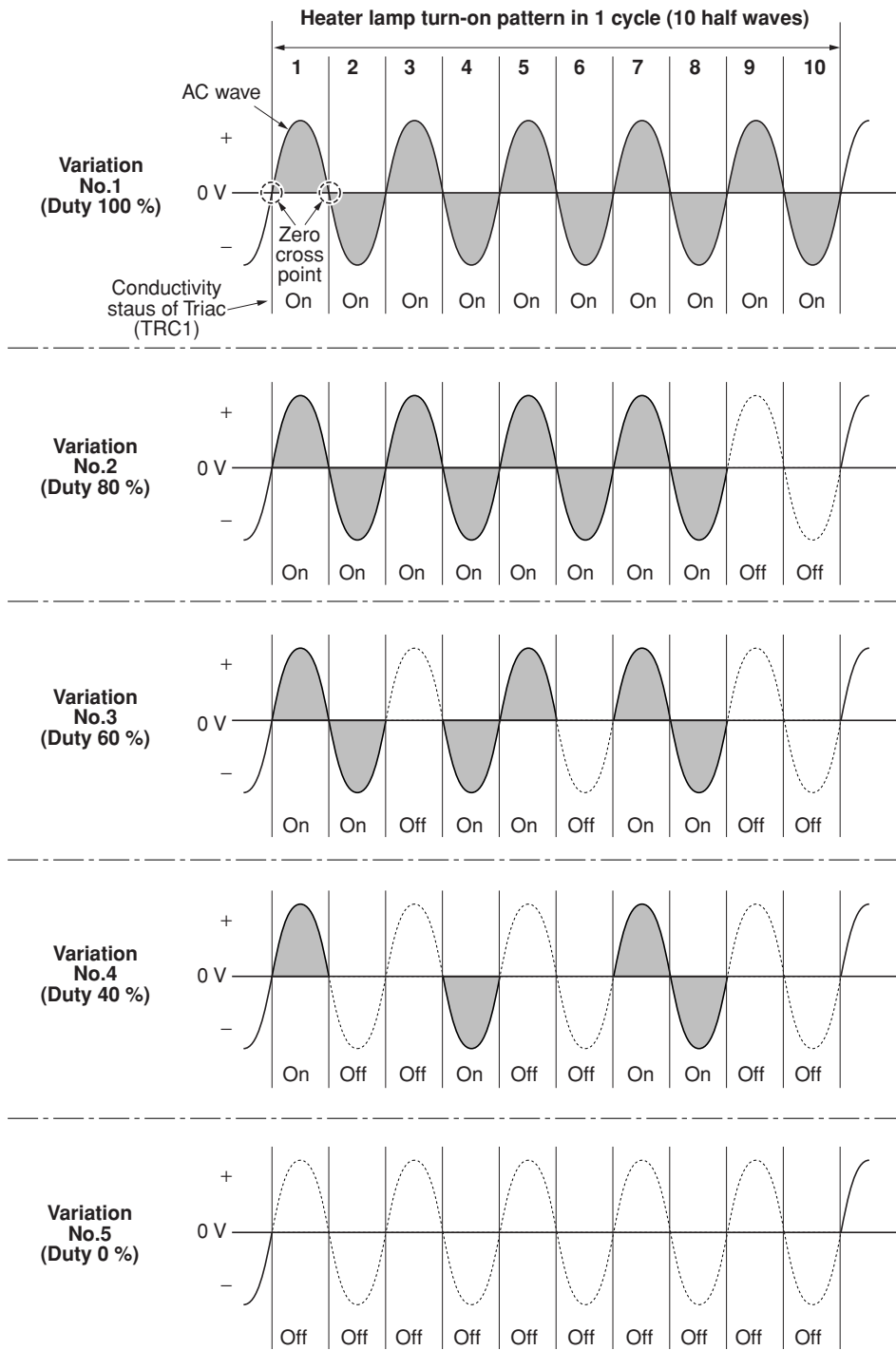

Figure 2-3-7 Heater lamp turn-on variations

(3) Polygon motor control circuit

The main controller board supplies the 2598.4 Hz clock pulse (PLGCLK) via the engine board to the PLL control IC (IC1) for the polygon motor. To begin printing, the engine CPU U1 turns PLGDR to H level, the PLL control IC (IC1) starts to revolve the polygon motor so that the revolution is 25,984 rpm which depends on the PLGCLK clock pulse. When PLL control IC (IC1) finds that the polygon motor is revolving at the rated speed, turns PLGDRN to L level to acknowledge the engine CPU that the rated speed has been achieved.

On the contrary, if PLGRDYN does not turn to L level within 8 seconds since PLGDRN has been L level.

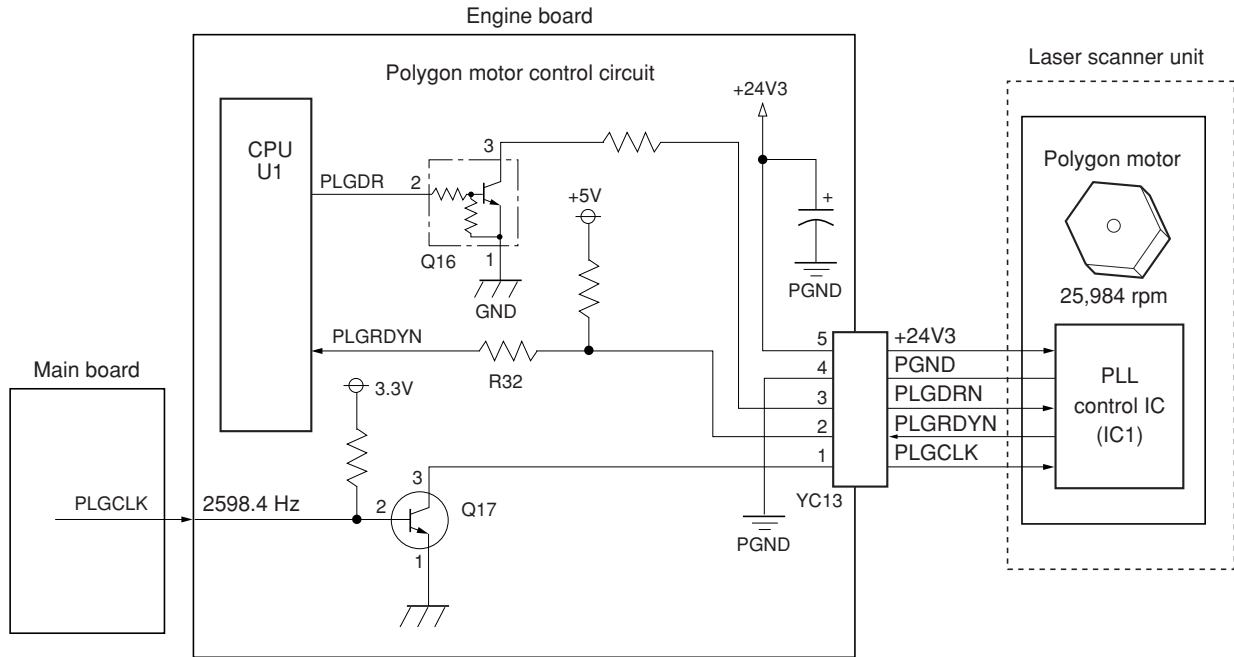

Figure 2-3-8 Polygon motor control circuit

Connector	Pin No.	Signal	I/O	Description
YC3	1	SGND	-	Ground
Connected to the main board	2	OVSYNK	O	OVSYNK signal
	3	SGND	-	Ground
	4	RSTN	O	RSTN signal
	5	SGND	-	Ground
	6	EGRN	O	EGRN signal
	7	SDIR	O	SDIR signal
	8	SBSY	O	SBSY signal
	9	PDMASKN	O	PDMASKN signal
	10	EGSI	I	EGSI signal
	11	SCKN	I	SCKN signal
	12	EGSO	O	EGSO signal
	13	PLGCLK	I	PLGCLK signal
	14	SGND	-	Ground
	15	OUTPEN	O	OUTPEN signal
	16	+5 V	O	5 V DC power supply
	17	+3.3 V	O	3.3 V DC power supply
	18	+3.3 V	O	3.3 V DC power supply
	19	SGND	-	Ground
	20	SGND	-	Ground
YC4	1	FEDDRN	O	Feed clutch: On/Off
Connected to the main motor	2	PFSEN	I	Paper feeder control signal
	3	PFPER	I	Paper feeder control signal
	4	PFCLK	O	Paper feeder control signal
	5	PFMDRN	O	Paper feeder control signal
	6	PGND	-	Ground
	7	+5 V	O	5 V DC power supply
	8	MRDYN	I	Main motor ready signal
	9	MOTORN	O	Main motor: On/Off
	10	+24 V3	O	24 V DC power supply
	YC5	1	+24 V3	O
Connected to the MP feed clutch	2	MPFDRN	O	MP feed clutch: On/Off
YC6	1	+24 V3	O	24 V DC power supply
Connected to the registration clutch	2	REGDRN	O	Registration clutch: On/Off
YC7	1	HEATN	O	Heater lamp: On/Off
Connected to the bias board	2	HVISEL	O	HVISEL signal
	3	+5 V	O	5 V DC power supply
	4	SLEEPS	O	Sleep mode signal: On/Off
	5	SLEEP24	O	Sleep mode signal: On/Off
	6	PSEL1	O	PSEL1 signal
	7	EXITN	I	Exit sensor: On/Off
	8	MHVDR2	O	Main charger grid bias voltage
	9	ZCROSS	I	Zero-cross signal
	10	HVCLK	O	HVCLK signal
	11	+5 V	O	5 V DC power supply
	12	+5 V	O	5 V DC power supply
	13	+5 V	O	5 V DC power supply
	14	SGND	-	Ground
	15	SGND	-	Ground
	16	SGND	-	Ground

Connector	Pin No.	Signal	I/O	Description
YC8	1	+24 V3	O	24 V DC power supply
Connected to the bias board	2	+24 V3	O	24 V DC power supply
	3	PGND	-	Ground
	4	PGND	-	Ground
	5	PAPER_N	I	Paper sensor: On/Off
	6	SWIN	I	Cassette switch: On/Off
	7	RESIT	I	Registration sensor: On/Off
	8	TONEREPY	I	Toner sensor: On/Off
	9	+24 V2	O	24 V DC power supply
	10	MHVDR1	O	Main charger grid bias voltage
	11	FAN2	O	Cooling fan: On/Off
	12	FAN1	O	Cooling fan: On/Off
	13	THVDR	O	Transfer roller bias voltage
	14	THERM	I	Thermistor detection voltage
	15	RTHVDR	O	Separation charger bias voltage
YC9	1	+5 V	O	5 V DC power supply
Connected to the MP paper sensor	2	HANDSN	I	MP paper sensor: On/Off
	3	SGND	-	Ground
YC10	1	TEMP	I	Temperature detection data
Connected to the scanner board	2	+5 V	O	5 V DC power supply
	3	SGND	-	Ground
	4	HPSWN	I	Scanner home position sensor: On/Off
	5	DPDET_N	I	DP set status: Installed/Not installed
	6	DPTIMSWN	I	DPTSW: On/Off
	7	DPORGSWN	I	OSLSW: On/Off
	8	DPCOVSWIN	I	DPSSW1: On/Off
	9	OPSWIN	I	DPSSW2: On/Off
	10	CCDSLEPN	O	CCD sleep signal
YC11	1	MOTA	O	OCM drive control signal
Connected to the scanner board	2	MOTNA	O	OCM drive control signal
	3	MOTB	O	OCM drive control signal
	4	MOTNB	O	OCM drive control signal
	5	DPMOT0	O	OFM drive control signal
	6	DPMOT1	O	OFM drive control signal
	7	SCANMOT0	O	Scanner motor drive control signal
	8	SCANMOT1	O	Scanner motor drive control signal
	9	LAMP	O	Exposure lamp: On/Off
	10	LAMPHI	O	Exposure lamp control signal
	11	LAMPLOW	O	Exposure lamp control signal
	12	PGND	-	Ground
	13	+24 V3	O	24 V DC power supply
YC12	1	+5 V	O	5 V DC power supply
Connected to the waste toner sensor	2	TNFULL	I	Waste toner sensor: On/Off
	3	SGND	-	Ground
YC13	1	PLGCLK	O	Polygon motor rotation clock
Connected to the laser scanner unit	2	PLGRDYN	I	Polygon motor rotation status
	3	PLGDRN	O	Polygon motor: On/Off
	4	PGND	-	Ground
	5	+24 V3	O	24 V DC power supply

Connector	Pin No.	Signal	I/O	Description
YC14	1	ERASPW	O	24 V DC power supply
Connected to the eraser lamp	2	ERASERN	O	Eraser lamp: On/Off
	3	PGND	-	Ground

2-3-3 Power supply board

The power supply board provides the AC power input and DC power and outputs. The high voltage bias generator circuit is mounted on a separate board. A simplified schematic diagram is shown below.

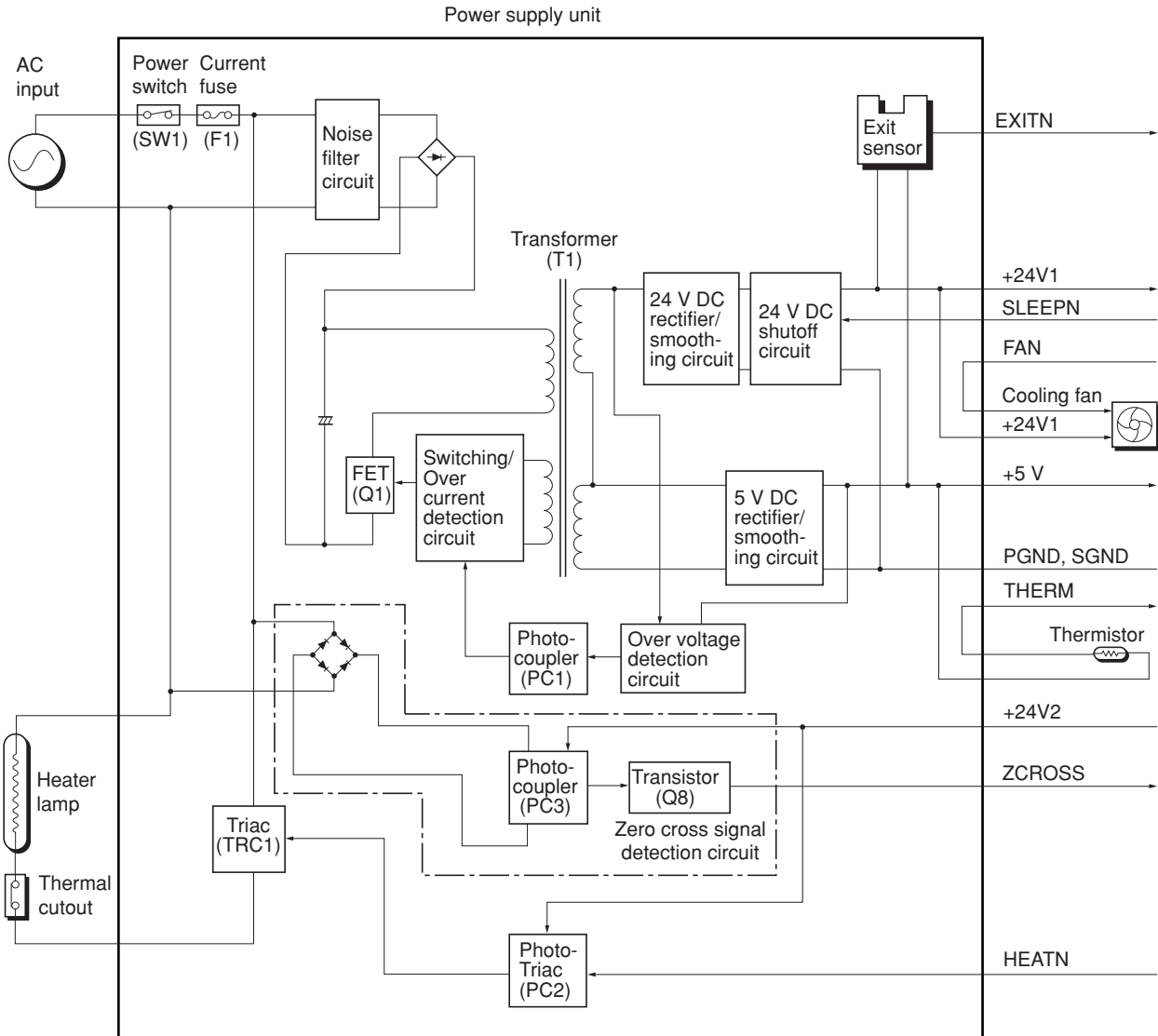
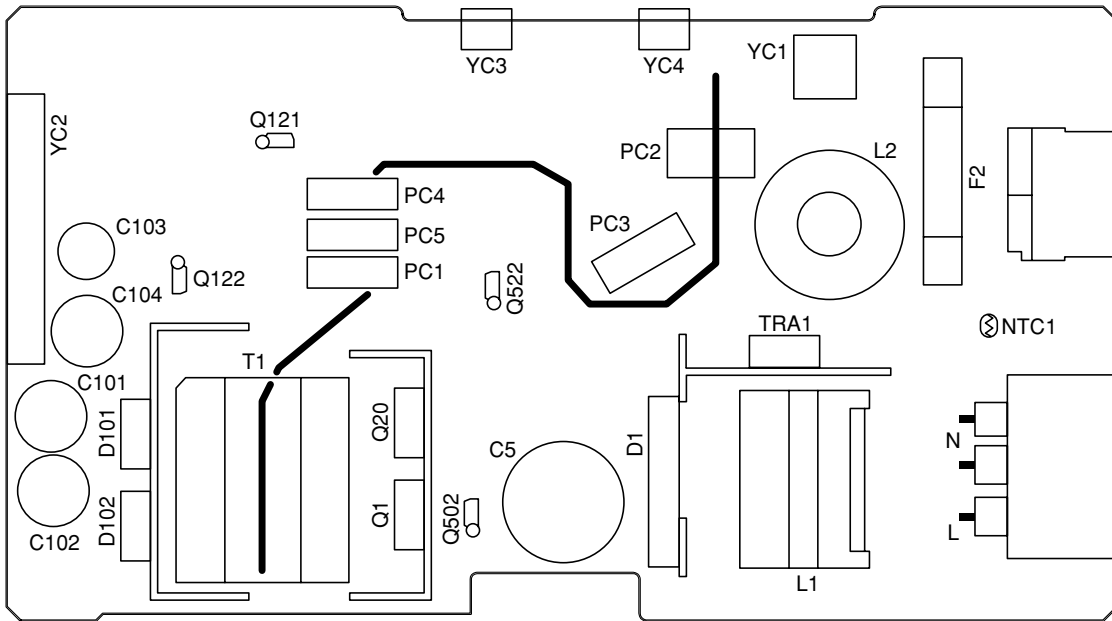

Figure 2-3-9 Power supply board circuit block diagram

• 100 V



• 200 V

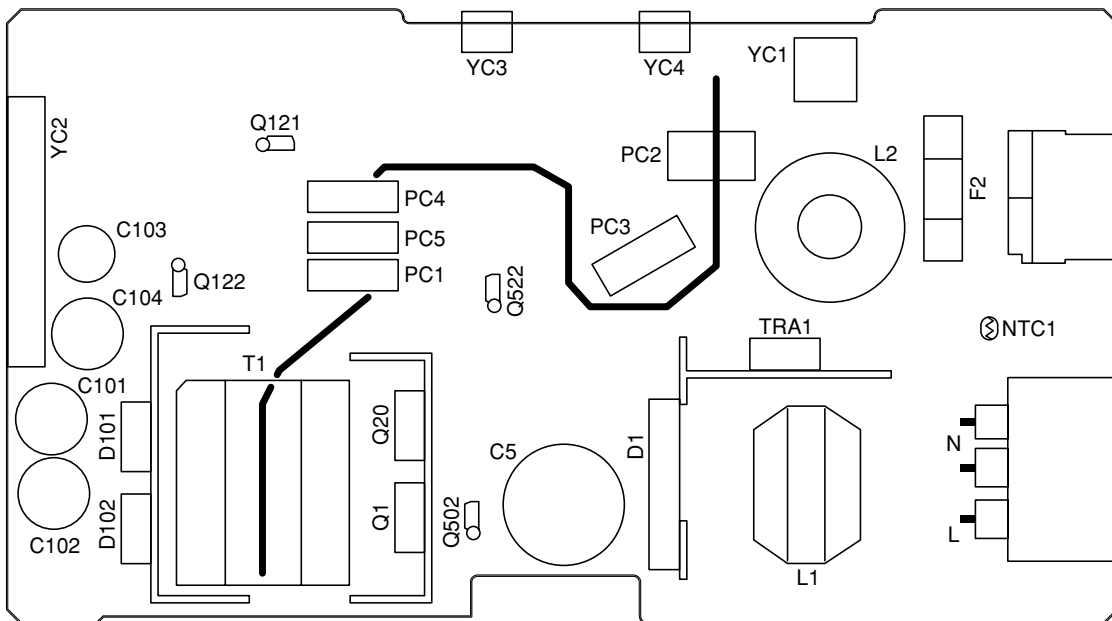

Figure 2-3-10 Power supply board silk-screen diagram

2-3-4 Bias board

The bias board contains the developing bias output circuit, registration sensor, paper empty sensor, and the cassette switch. It also provides a liaison connection to the high voltage board, power supply, and the toner sensor.

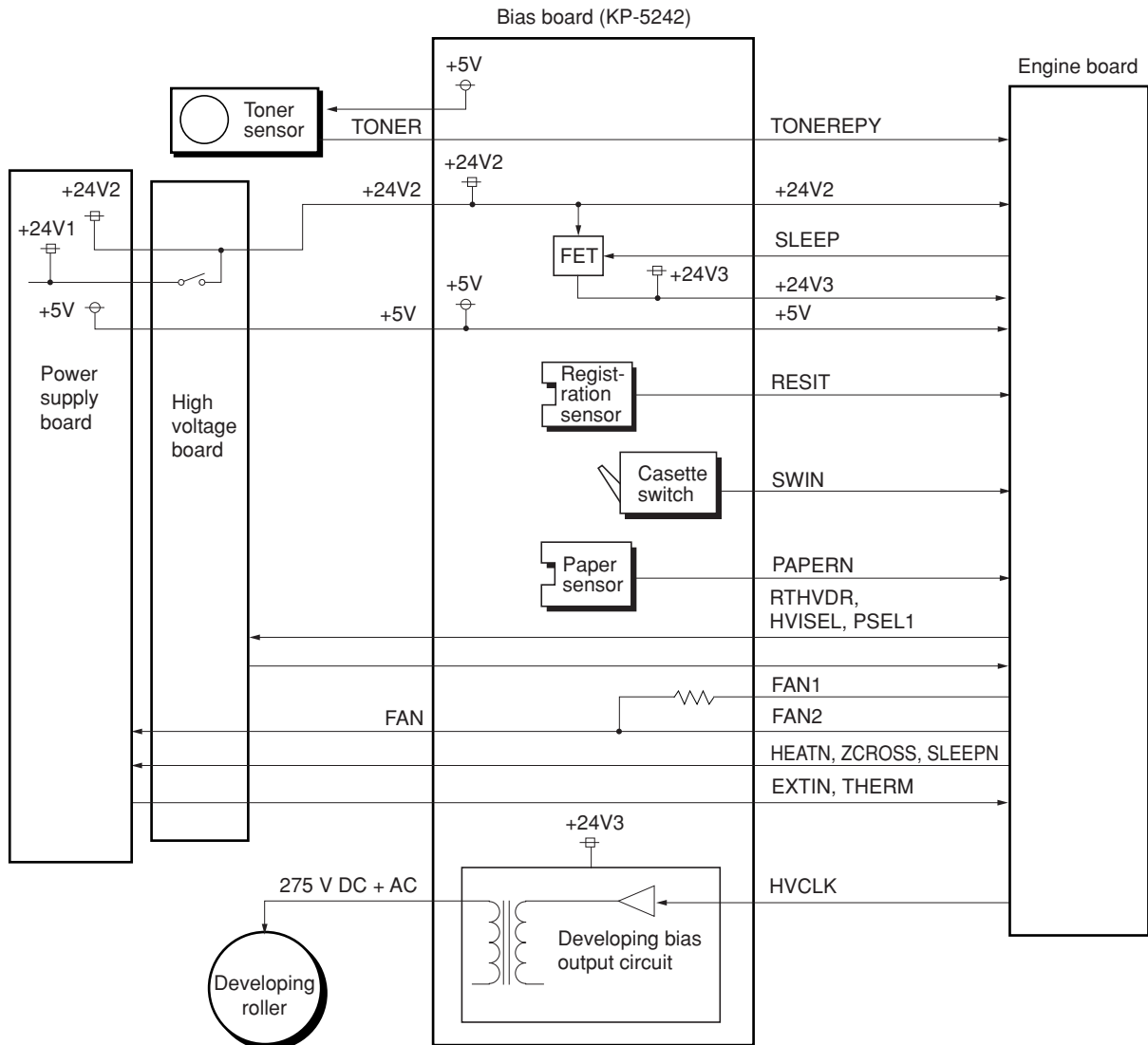

Figure 2-3-11 Bias board circuit block diagram

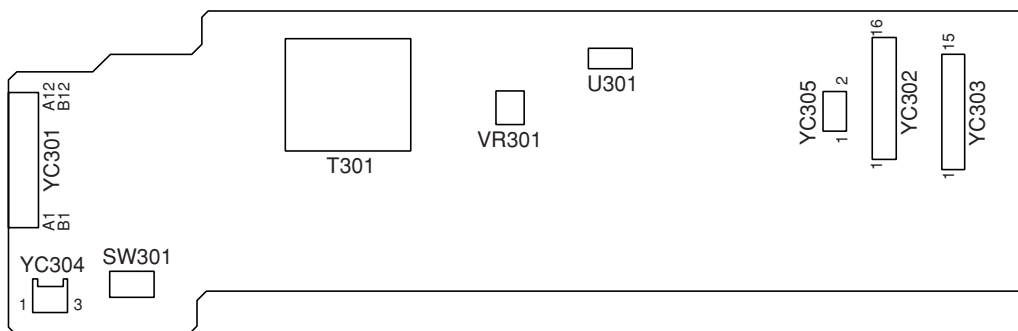

Figure 2-3-12 Bias board silk-screen diagram

2-3-5 High voltage board

The high voltage board contains the high voltage output circuit, interlock switch circuit as well as providing a liaison connection with the power supply board, bias board, and the engine board.

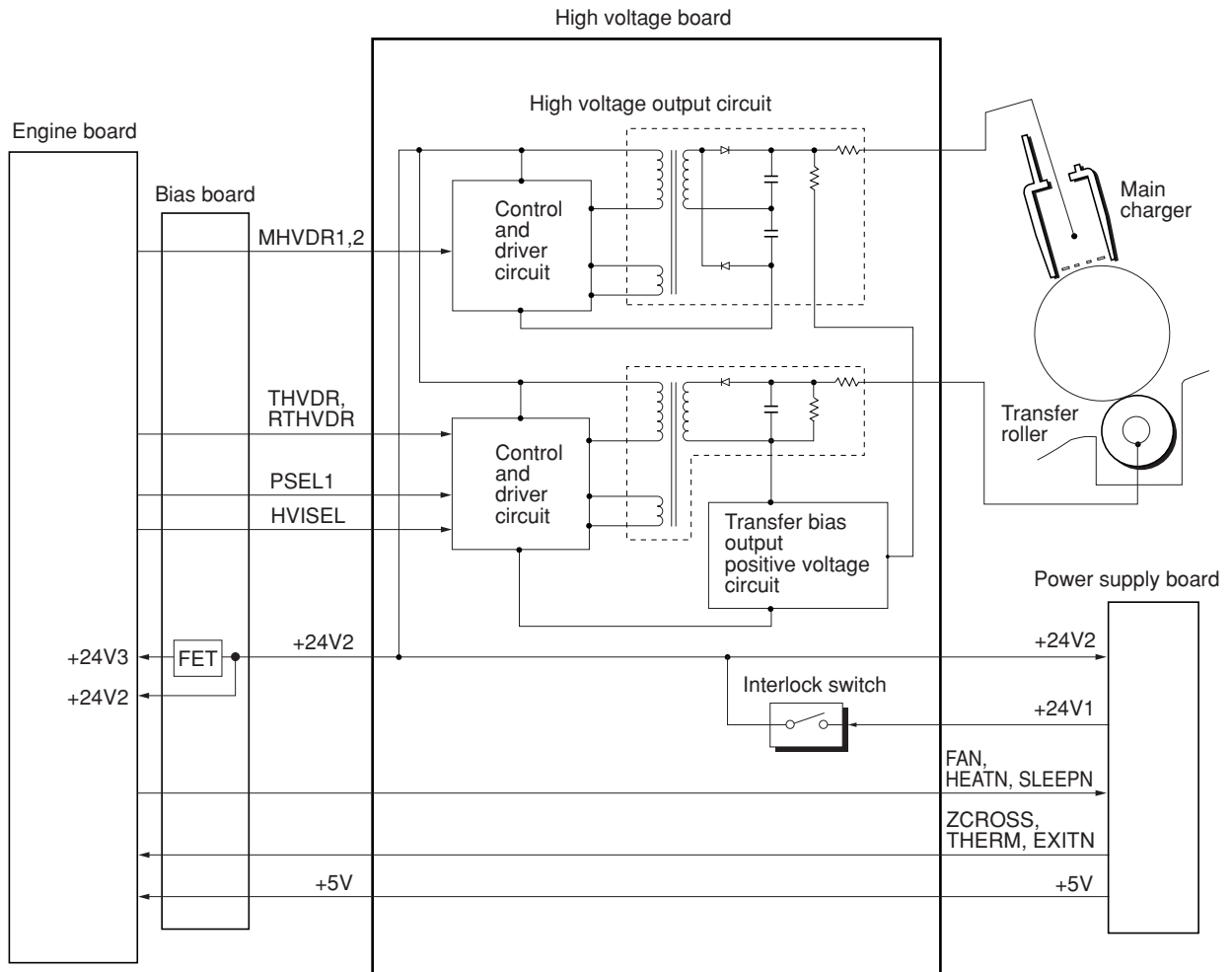

Figure 2-3-13 High voltage board circuit block diagram

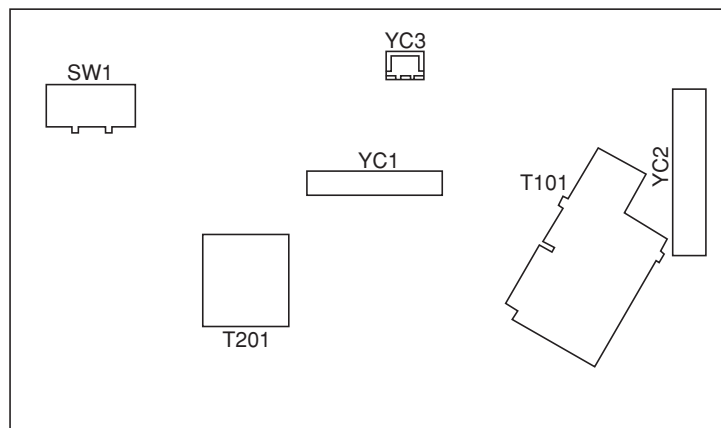

Figure 2-3-14 High voltage board silk-screen diagram

(1) Interlock switch

The interlock switch is located on the high voltage board and opened and closed in conjunction with the front cover or the front top cover via the interlock lever. This switch connects and disconnects the +24 V DC power supply line. If the front cover or the front top cover is open, the interlock switch is open, and the +24 V DC to the high voltage output circuit, bias board, engine board, and the power supply board is disconnected, deactivating the high voltage output, laser output, main motor output for safety. The cooling fan is an exception: Since the cooling fan is directly fed with +24 V DC from the power supply unit at the primary side (+24V1) of the interlock switch, the cooling fan is not deactivated even the cover is open.

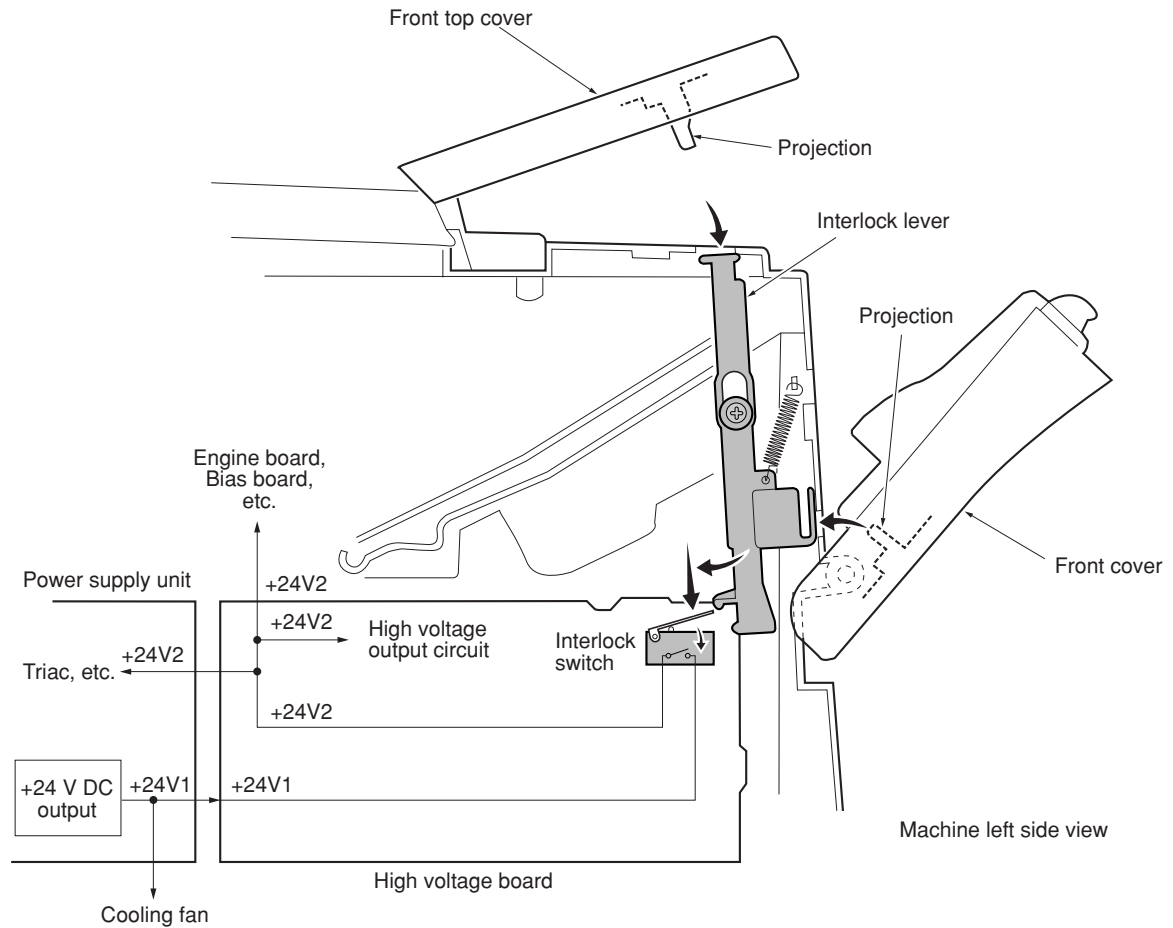

Figure 2-3-15 Interlock switch

2-3-6 CCD board

The CCD board consists mainly of a CCD sensor (U4) that scans an original. The CCD sensor (U4) is driven to scan an original by the CCD sensor control signals (CCDCLKN, SH_BW, SH_RGB, SW, SWN, CPN, and RSN) based on the clock for driving the CCD sensor (CCDCLK) supplied from the main board through the scanner board.

The image signals obtained from scanning of an original are divided into three analog signals (CCDR2, CCDG2, and CCDB2) for output. These signals are current-amplified by the amplification circuit that consists of operational amplifiers (U6 and U7), and so on and transmitted to the analog signal processing circuit on the main board through the scanner board.

Also the CCD board relays signal lines of the scanner home position sensor and the exposure lamp.

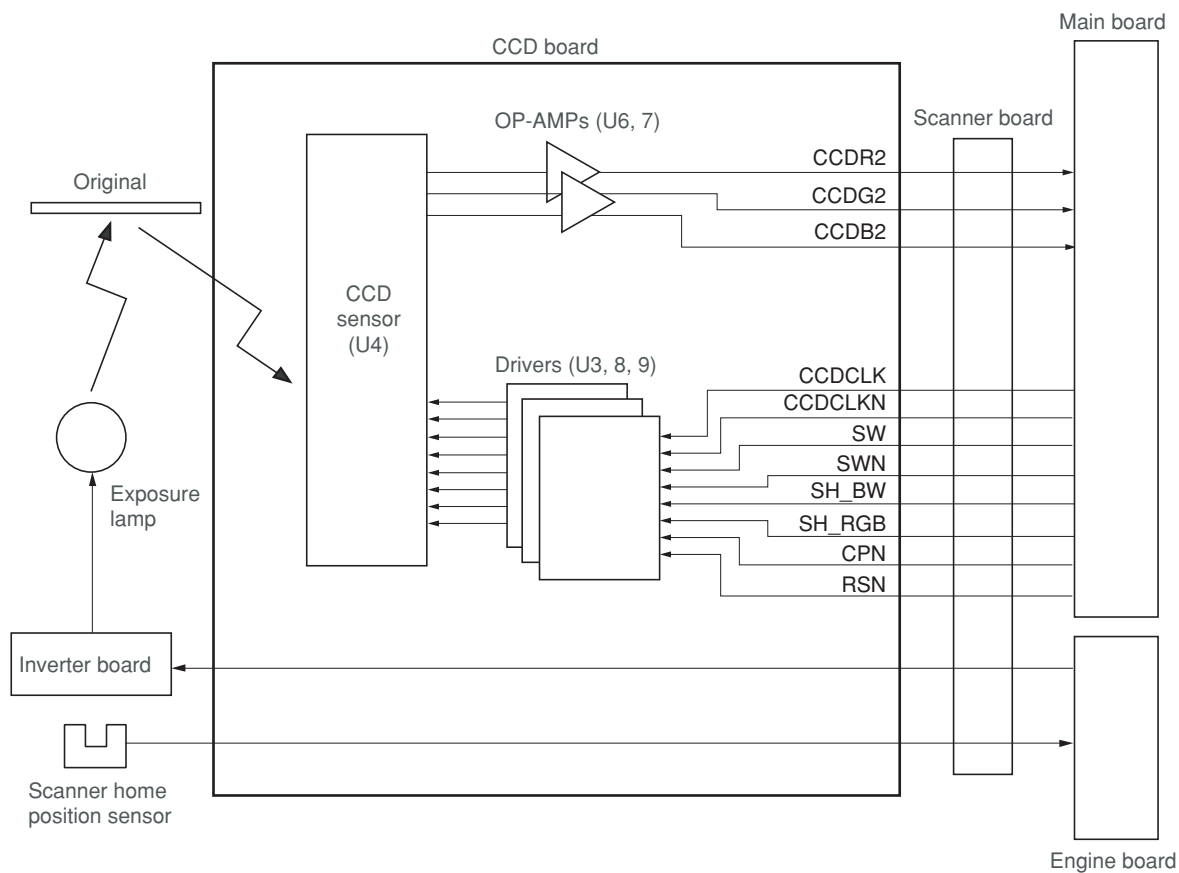

Figure 2-3-16 CCD board circuit block diagram

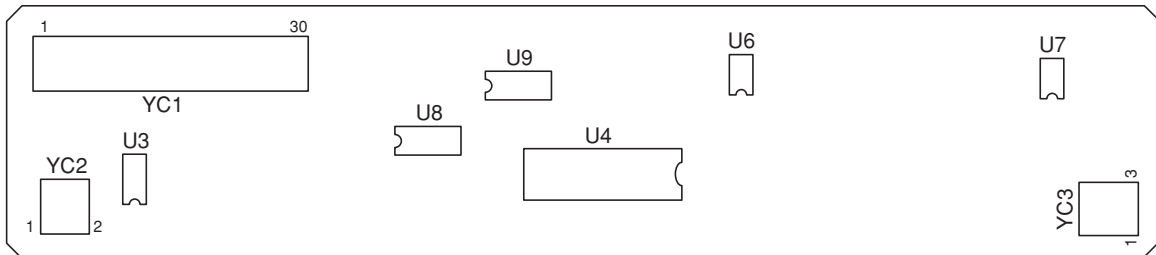

Figure 2-3-17 CCD board silk-screen diagram

Connector	Pin No.	Signal	I/O	Description
YC1 Connected to the scanner board	1	GND	-	Ground
	2	GND	-	Ground
	3	GND	-	Ground
	4	SW	I	Color/monochro control signal
	5	SWN	I	Color/monochro control signal
	6	SH	I	CCD shift signal
	7	GND	-	Ground
	8	CPN	I	CCD CP signal
	9	GND	-	Ground
	10	RSN	I	CCD RS signal
	11	GND	-	Ground
	12	CCDCLK	I	CCD clock signal
	13	GND	-	Ground
	14	CCDCLKN	I	CCD clock signal
	15	GND	-	Ground
	16	GND	-	Ground
	17	GND	-	Ground
	18	CCDG(O)	O	Image data G (green) signal (analog)
	19	GND	-	Ground
	20	CCDB(E)	O	Image data B (blue) signal (analog)
	21	GND	-	Ground
	22	CCDR	O	Image data R (red) signal (analog)
	23	+12 V	I	12 V DC power supply
	24	+5 V	I	5 V DC power supply
	25	+5 V	I	5 V DC power supply
	26	HPSWN	O	Scanner home position sensor: On/Off
	27	PGND	-	Ground
	28	PGND	-	Ground
	29	LAMP	I	Exposure lamp: On/Off
	30	LAMP	I	Exposure lamp: On/Off
YC2 Connected to the inverter board	1	LAMP	O	Exposure lamp: On/Off
	2	PGND	-	Ground
YC3 Connected to the scanner home position sensor	1	GND	-	Ground
	2	HPSWN	I	Scanner home position sensor: On/Off
	3	+5 V	O	5 V DC power supply

2-3-7 Operation board

The operation board consists of key switches and LEDs. The lighting of LEDs is determined by scan signals (SCAN0 to SCAN7) and LED lighting selection signals (LED0 to LED3) from the main board. The key switches operated are identified by the scan signals (SCAN0 to SCAN7) and the return signals (KEYIN0 to KEYIN7).

As an example, to light “LEDG9”, the LED lighting selection signal (LED3) should be driven low in synchronization with a low level on the scan signal (SCAN0). LEDs can be lit dynamically by repeating such operations.

As another example, if “K9” is pressed, the corresponding key switch is turned on feeding the low level of the scan signal (SCAN6) back to the main board via the return signal (KEYIN7). The main board locates the position where the line outputting the scan signal and the line inputting the return signal cross, and thereby determines which key switch was operated.

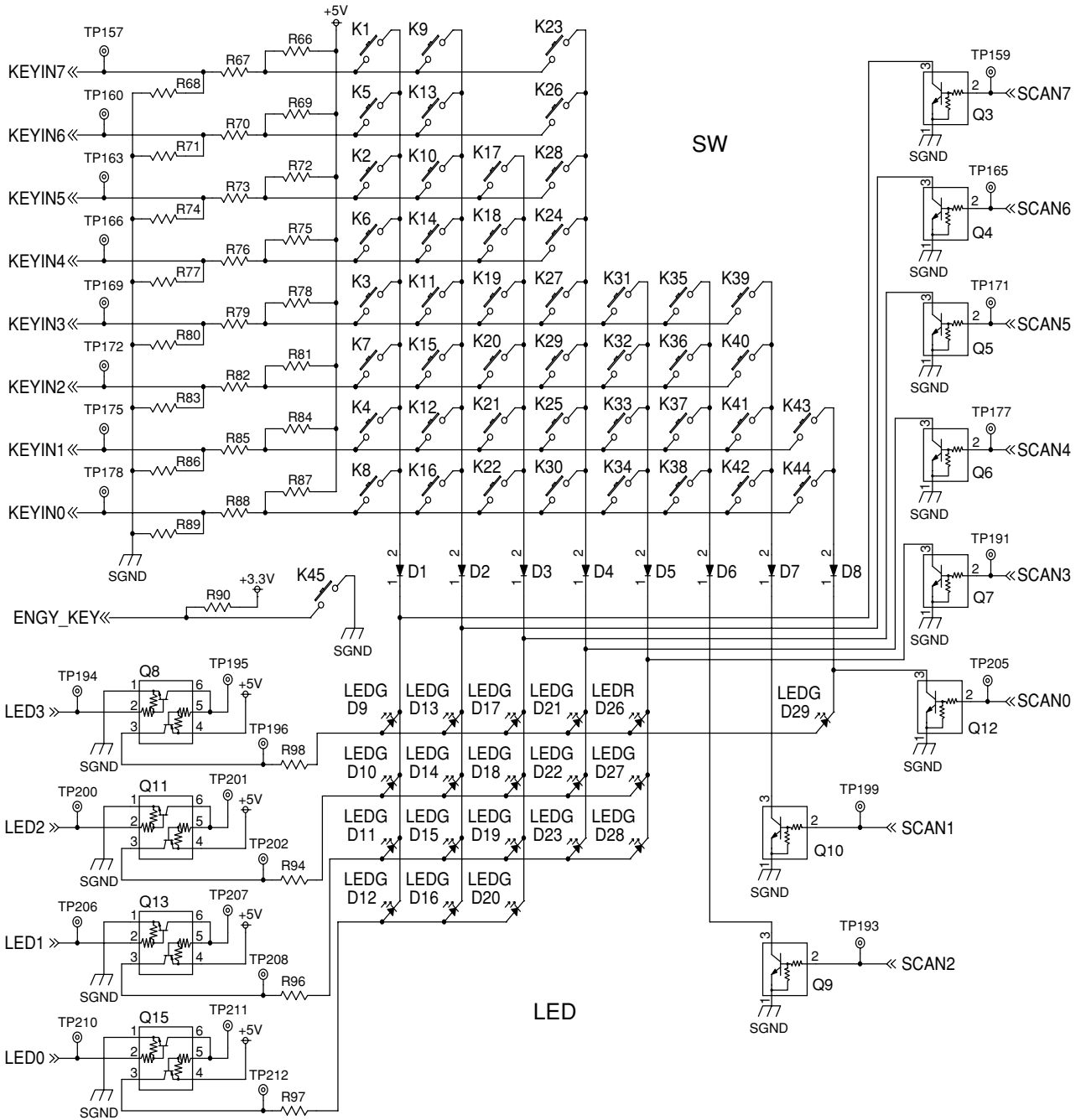

Figure 2-3-18 Operator board circuit block diagram

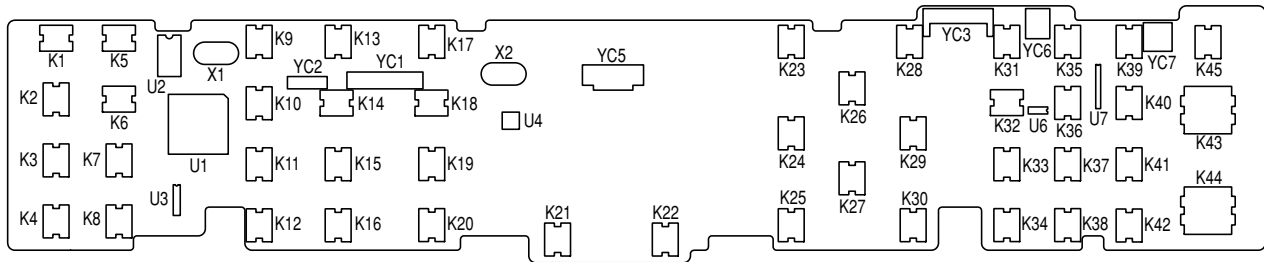

Figure 2-3-19 Operator board silk-screen diagram

Connector	Pin No.	Signal	I/O	Description
YC3 Connected to the main board	1	SGND	-	Ground
	2	AUDIO		AUDIO signal
	3	+5 V		5 V DC power supply
	4	FPRST		FPRST signal
	5	PANTXD		PANTXD signal
	6	PANRXD	O	PANRXD signal
	7	PANRTS		PANRTS signal
	8	PANCTS	O	PANCTS signal
	9	+3.3 V		3.3 V DC power supply
	10	CHECK		CHECK signal
	11	TEMP	O	Temperature detection data
YC5 Connected to the LCD	1	SGND	-	Ground
	2	V5	O	V5 signal
	3	V4	O	V4 signal
	4	V3	O	V3 signal
	5	V2	O	V2 signal
	6	V1	O	V1 signal
	7	CAP2+	O	CAP2+ signal
	8	CAP2-	O	CAP2- signal
	9	CAP1-	O	CAP1- signal
	10	CAP1+	O	CAP1+ signal
	11	CAP3-	O	CAP3- signal
	12	Vout	-	Ground
	13	Vss	-	Ground
	14	Vdd	O	3.3 V DC power supply
	15	SI	O	SI signal
	16	SCL	O	SCL signal
	17	A0	O	A0 signal
	18	/RES	O	/RES signal
	19	/CS1	O	/CS1 signal
	20	SGND	-	Ground
YC6 Connected to the speaker	1	OUT-	O	OUT- signal
	2	OUT+	O	OUT+ signal

2-3-8 Scanner board

The scanner board consists of scanner driver circuit Q1 to Q5 and exposure lamp driver circuit U1, relays signals from engine board, main board, operation board, CCD board and optional document processor.

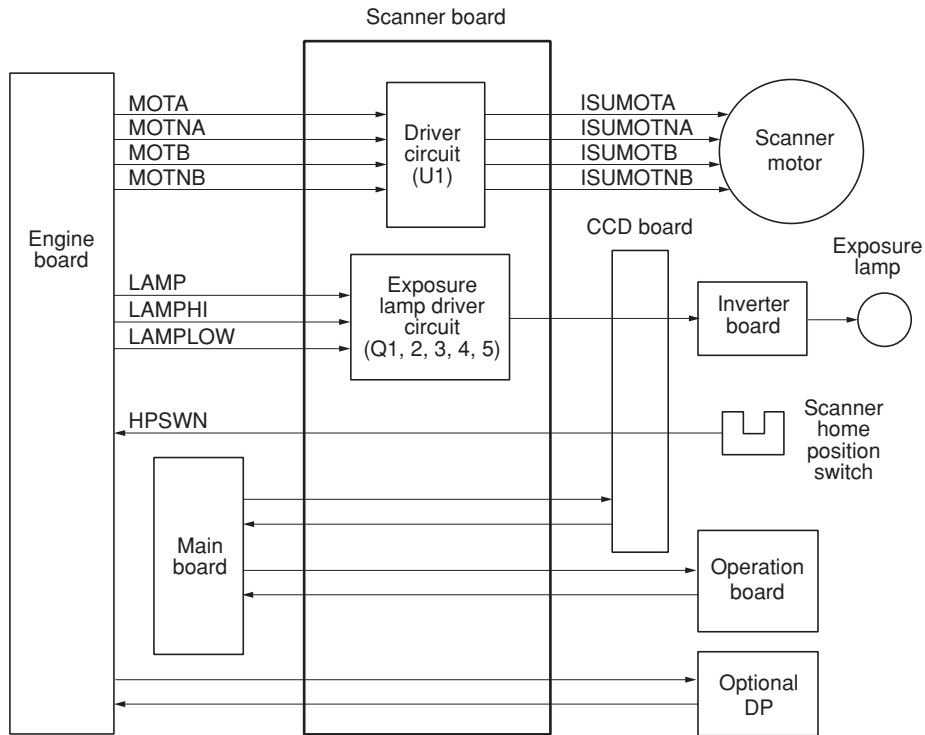

Figure 2-3-20 Scanner board circuit block diagram

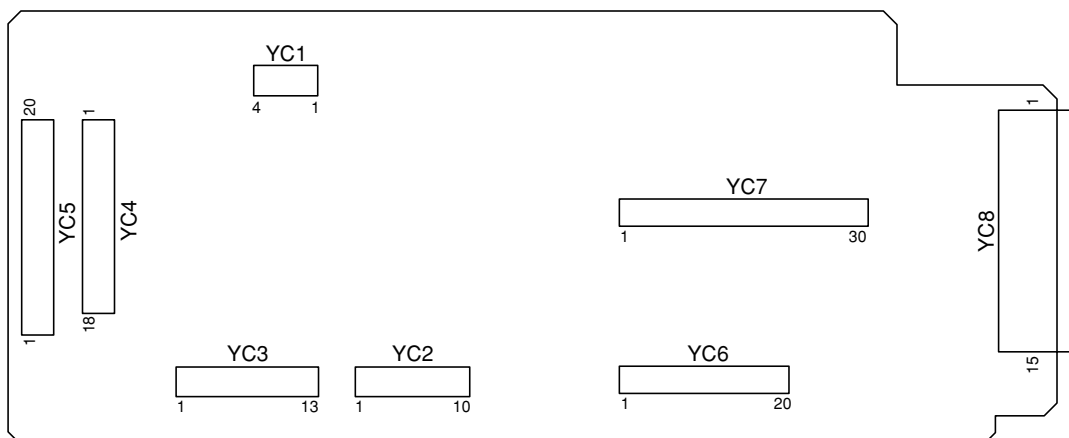
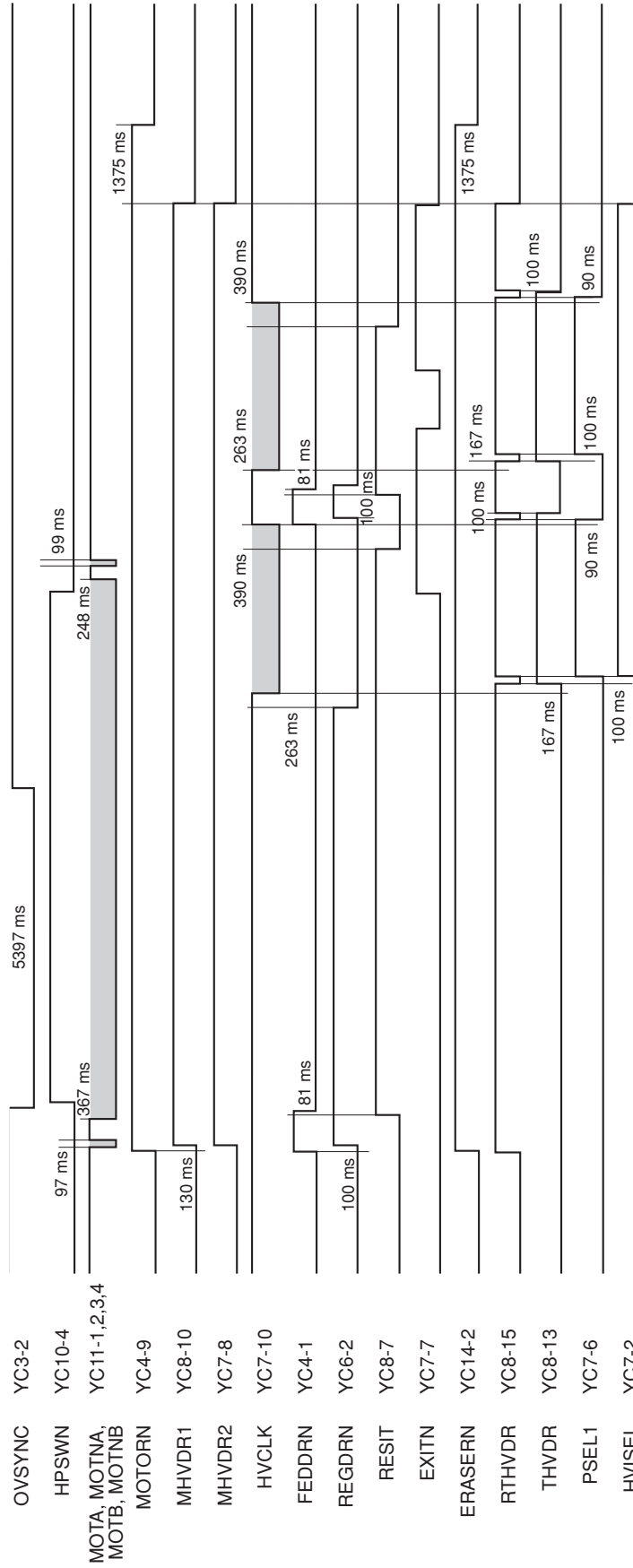
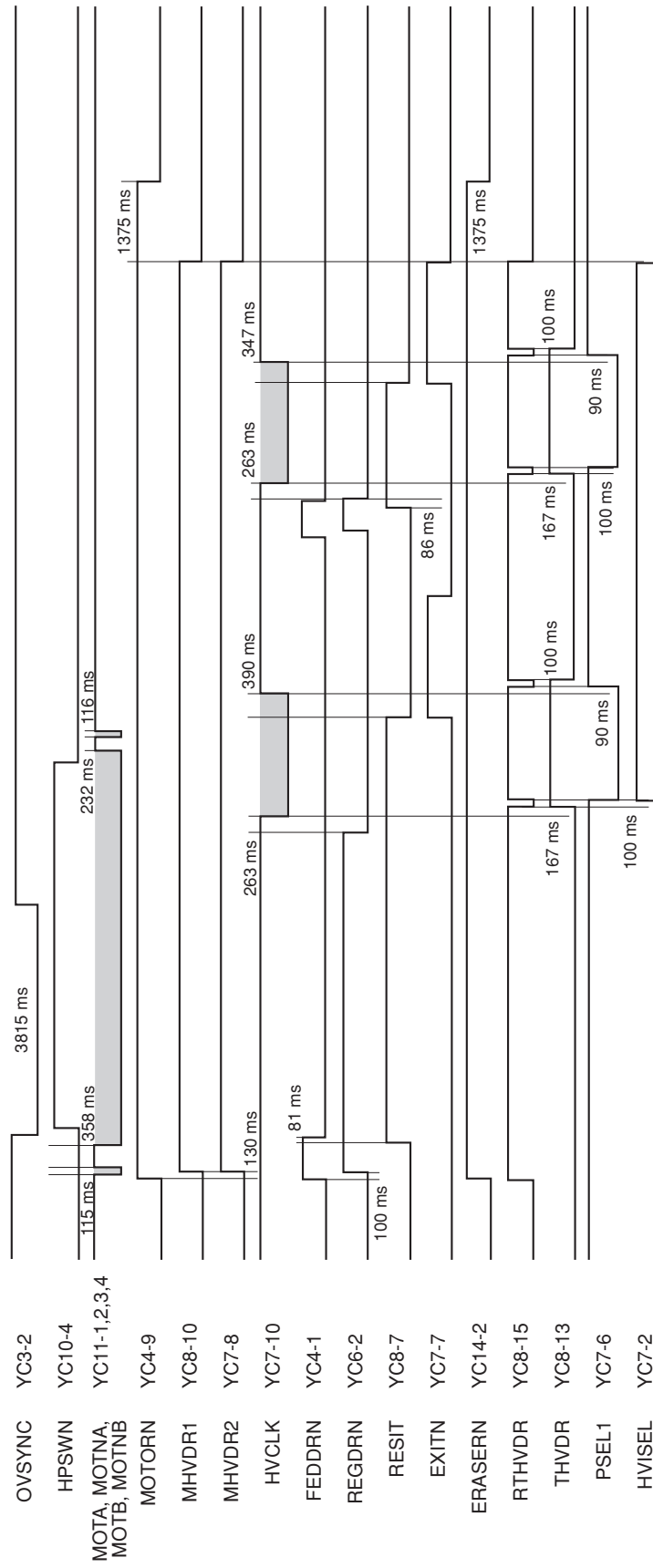

Figure 2-3-21 Scanner board silk-screen diagram

Timing chart No. 1 Continuous copying of an A4R/81/2" x 11" original onto two sheets of A4R/81/2" x 11"R copy paper



Timing chart No. 2 Continuous copying of an A5R/5 1/2"x8 1/2" original onto two sheets of A5R/5 1/2"x8 1/2" copy paper



Timing chart No. 3 Continuous copying of an B5R original onto two sheets of B5R copy paper

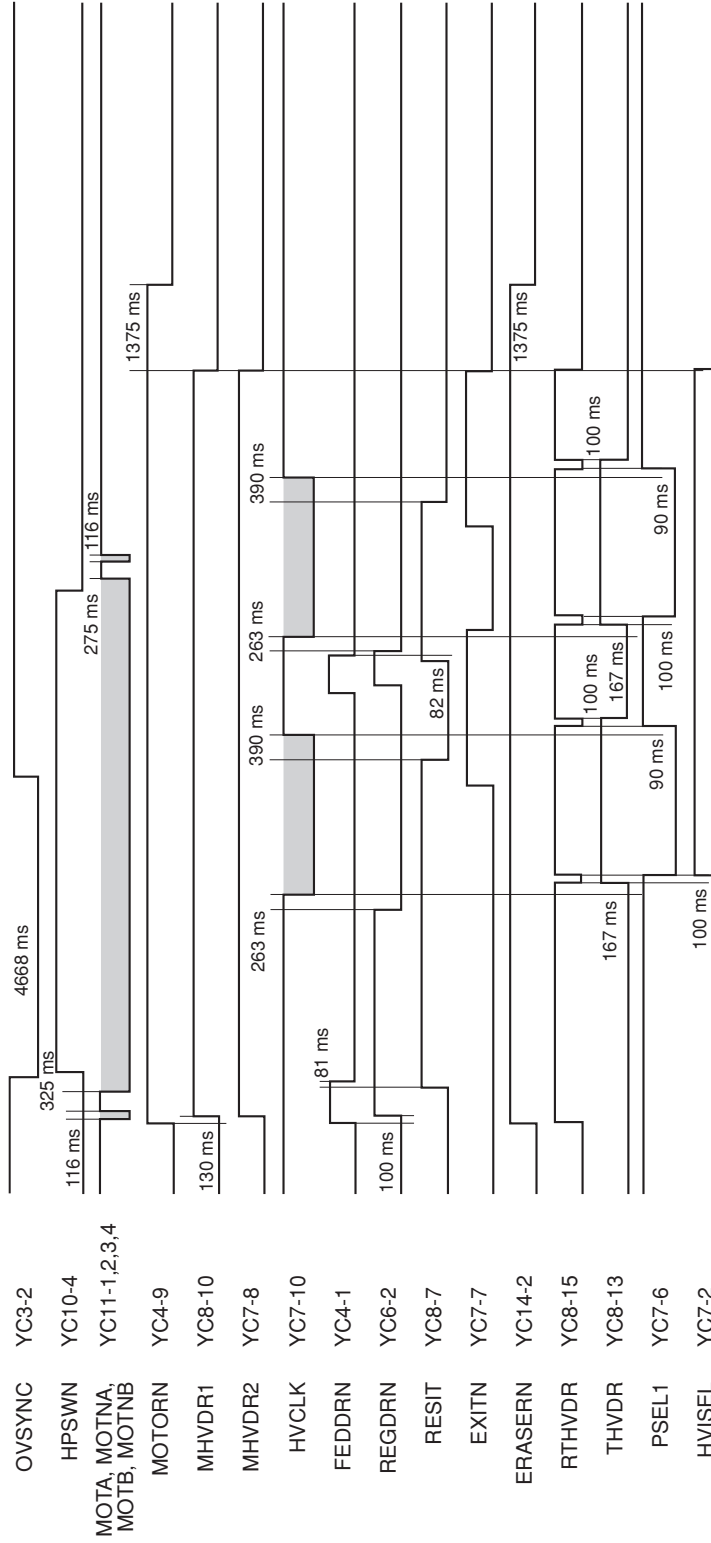

Wiring diagram

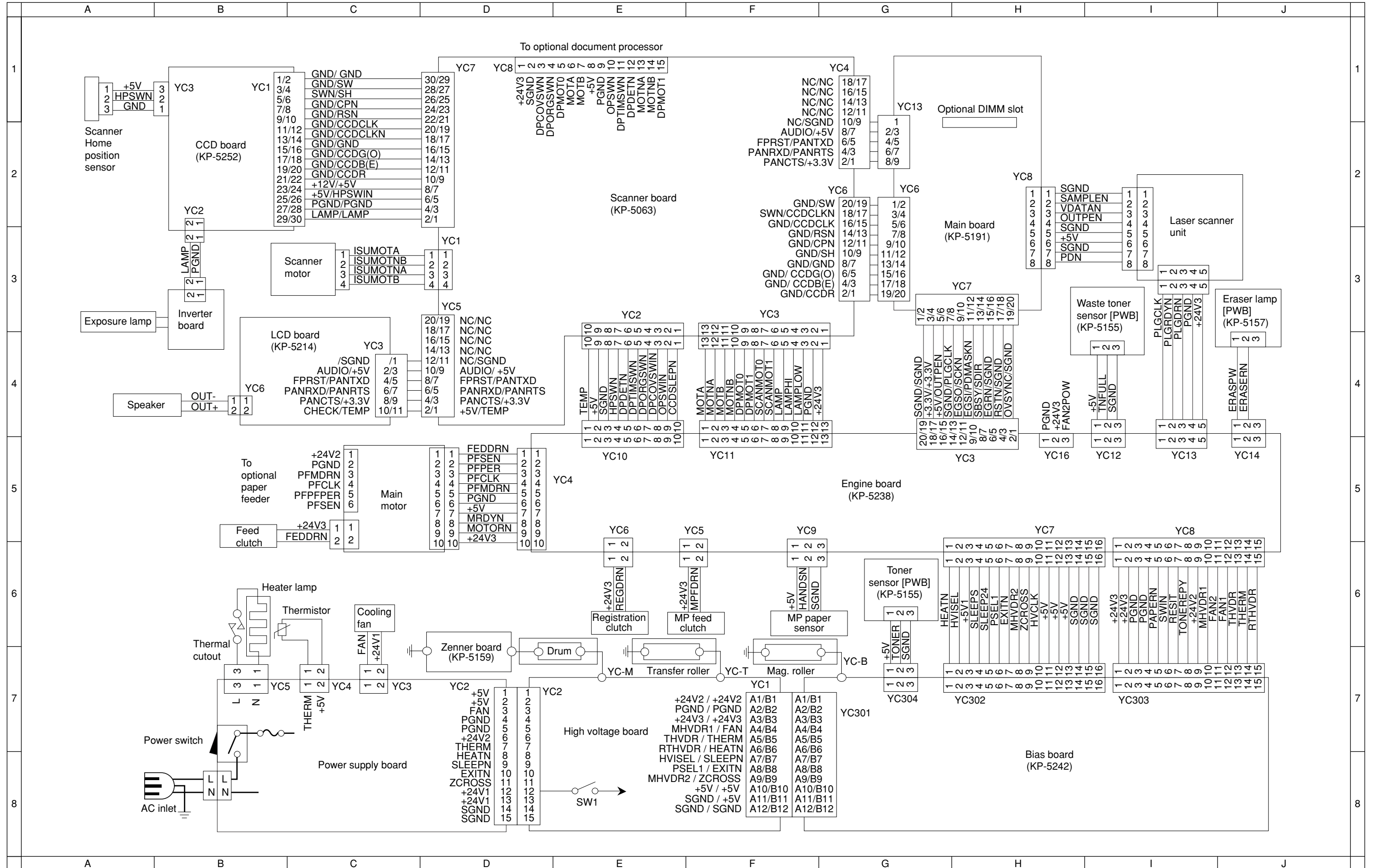

KYOCERA MITA EUROPE B.V.

Hoeksteen 40, 2132 MS Hoofddorp,
The Netherlands
Phone: +31.(0)20.654.000
Home page: <http://www.kyoceramita-europe.com>
Email: info@kyoceramita-europe.com

KYOCERA MITA NEDERLAND B.V.

Hoeksteen 40 2132 MS Hoofddorp
The Netherlands
Phone: +31.(0)20.587.7200

KYOCERA MITA (UK) LTD.

8 Beacontree Plaza
Gillette Way,
Reading Berks RG2 0BS, UK
Phone: +44.(0)118.931.1500

KYOCERA MITA ITALIA S.P.A.

Via Verdi 89 / 91 20063 Cernusco sul Naviglio,
Italy
Phone: +39.02.92179.1

S.A. KYOCERA MITA BELGIUM N.V.

Hermesstraat 8A 1930 Zaventem Belgium
Phone: +32.(0)2.720.9270

KYOCERA MITA FRANCE S.A.

Parc Les Algorithmes
Saint Aubin
91194 GIF-SUR-YVETTE
France
Phone: +33.(0)1.6985.2600

KYOCERA MITA ESPAÑA S.A.

Edificio Kyocera, Avda de Manacor N. 2,
Urb. Parque Rozas 28290 Las Rozas,
Madrid, Spain
Phone: +34.(0)91.631.8392

KYOCERA MITA FINLAND OY

Kirvesmiehenkatu 4 00810 Helsinki,
Finland
Phone: +358.(0)9.4780.5200

KYOCERA MITA (SCHWEIZ) AG

Holzliwisen Industriestrasse 28
8604 Volketswil, Switzerland
Phone: +41.(0)1.908.4949

KYOCERA MITA DEUTSCHLAND GMBH

Mollsfeld 12 D-40670 Meerbusch,
Germany
Phone: +49.(0)2159.918.0

KYOCERA MITA GMBH AUSTRIA

Eduard-Kittenberger Gasse 95
1230 Wien, Austria
Phone: +43.(0)1.86338.0

KYOCERA MITA SVENSKA AB

Box 1402 171 27 Solna, Sweden
Phone: +46.(0)8.546.550.00

KYOCERA MITA NORGE

Postboks 150 Oppsal, NO 0619 Oslo
Olaf Helsetsvei 6, NO 0694 Oslo
Phone: +47.(0)22.62.73.00

KYOCERA MITA DANMARK A/S

Slotsmarken 11, 2
DK-2970 Hørsholm, Denmark
Phone: +45.7022.3880

KYOCERA MITA PORTUGAL LDA.

Rua do Centro Cultural, no 41 1700-106
Lisbon, Portugal
Phone: +351.(0)21.842.9100

KYOCERA MITA SOUTH AFRICA

(PTY) LTD.

527 Kyalami Boulevard,
Kyalami Business Park 1685 Midrand South
Phone: +27.(0)11.466.3290

KYOCERA MITA AMERICA, INC.

Headquarters:

225 Sand Road,
Fairfield, New Jersey 07004-0008,
U.S.A.
Phone: (973) 808-8444

KYOCERA MITA AUSTRALIA PTY. LTD.

Level 3, 6-10 Talavera Road, North Ryde,
N.S.W. 2113 Australia
Phone: (02) 9888-9999

KYOCERA MITA NEW ZEALAND LTD.

1-3 Parkhead Place, Albany
P.O. Box 302 125 NHPC, Auckland,
New Zealand
Phone: (09) 415-4517

KYOCERA MITA (THAILAND) CORP., LTD.

9/209 Ratchada-Prachachem Road,
Bang Sue, Bangkok 10800, Thailand
Phone: (02) 586-0320

KYOCERA MITA SINGAPORE PTE LTD.

121 Genting Lane, 3rd Level,
Singapore 349572
Phone: 67418733

KYOCERA MITA HONG KONG LIMITED

11/F., Mita Centre,
552-566, Castle Peak Road,
Tsuen Wan, New Territories,
Hong Kong
Phone: 24297422

KYOCERA MITA TAIWAN

Corporation.
7F-1~2, No.41, Lane 221, Gangchi Rd.
Neihu District, Taipei, Taiwan, 114. R.O.C.
Phone: (02) 87511560

KYOCERA MITA

2-28, 1-chome, Tamatsukuri, Chuo-ku
Osaka 540-8585, Japan
Phone: (06) 6764-3555
<http://www.kyoceramita.com>

©2004 KYOCERA MITA Corporation

 **KYOCERA** is a trademark of Kyocera Corporation

Printed in Holland