

# Service Manual

iR5075/5065/5055 Series

**Canon**



## Application

This manual has been issued by Canon Inc. for qualified persons to learn technical theory, installation, maintenance, and repair of products. This manual covers all localities where the products are sold. For this reason, there may be information in this manual that does not apply to your locality.

## Corrections

This manual may contain technical inaccuracies or typographical errors due to improvements or changes in products. When changes occur in applicable products or in the contents of this manual, Canon will release technical information as the need arises. In the event of major changes in the contents of this manual over a long or short period, Canon will issue a new edition of this manual.

The following paragraph does not apply to any countries where such provisions are inconsistent with local law.

## Trademarks

The product names and company names used in this manual are the registered trademarks of the individual companies.

## Copyright

This manual is copyrighted with all rights reserved. Under the copyright laws, this manual may not be copied, reproduced or translated into another language, in whole or in part, without the written consent of Canon Inc.

***COPYRIGHT © 2001 CANON INC.***

*Printed in Japan*

## Caution









Use of this manual should be strictly supervised to avoid disclosure of confidential information.

---

# Symbols Used



---

This documentation uses the following symbols to indicate special information:

Symbol	Description
	Indicates an item of a non-specific nature, possibly classified as Note, Caution, or Warning.
	Indicates an item requiring care to avoid electric shocks.
	Indicates an item requiring care to avoid combustion (fire).
	Indicates an item prohibiting disassembly to avoid electric shocks or problems.
	Indicates an item requiring disconnection of the power plug from the electric outlet.
 Memo	Indicates an item intended to provide notes assisting the understanding of the topic in question.
 REF.	Indicates an item of reference assisting the understanding of the topic in question.
	Provides a description of a service mode.
	Provides a description of the nature of an error indication.

The following rules apply throughout this Service Manual:

1. Each chapter contains sections explaining the purpose of specific functions and the relationship between electrical and mechanical systems with reference to the timing of operation.

In the diagrams,  represents the path of mechanical drive; where a signal name accompanies the symbol, the arrow  indicates the direction of the electric signal.

The expression "turn on the power" means flipping on the power switch, closing the front door, and closing the delivery unit door, which results in supplying the machine with power.

2. In the digital circuits, '1' is used to indicate that the voltage level of a given signal is "High", while '0' is used to indicate "Low". (The voltage value, however, differs from circuit to circuit.) In addition, the asterisk (\*) as in "DRMD\*" indicates that the DRMD signal goes on when '0'.

In practically all cases, the internal mechanisms of a microprocessor cannot be checked in the field. Therefore, the operations of the microprocessors used in the machines are not discussed: they are explained in terms of from sensors to the input of the DC controller PCB and from the output of the DC controller PCB to the loads.

The descriptions in this Service Manual are subject to change without notice for product improvement or other purposes, and major changes will be communicated in the form of Service Information bulletins.

All service persons are expected to have a good understanding of the contents of this Service Manual and all relevant Service Information bulletins and be able to identify and isolate faults in the machine."



# Contents

## Chapter 1 Introduction

1.1 System Construction .....	1- 1
1.1.1 System Configuration with Pickup/Delivery Accessories (230V)EUR .....	1- 1
1.1.2 System Configuration with Printing/Transmission Accessories (230V)EUR .....	1- 1
1.1.3 Functions and Printing/Transmission Accessories (230V) .....	1- 2
1.2 Product Specifications .....	1- 3
1.2.1 Names of Parts .....	1- 3
1.2.1.1 External view .....	1- 3
1.2.1.2 Cross-Section .....	1- 5
1.2.2 Using the Machine .....	1- 7
1.2.2.1 Turning On the Power Switch .....	1- 7
1.2.2.2 Turning Off the Power Switch .....	1- 7
1.2.2.3 Control Panel .....	1- 9
1.2.3 User Mode Items .....	1- 9
1.2.3.1 Common Settings .....	1- 9
1.2.3.2 Timer Settings .....	1- 11
1.2.3.3 Adjustment/Cleaning .....	1- 11
1.2.3.4 Report Output .....	1- 11
1.2.3.5 System Control Settings .....	1- 12
1.2.3.6 Copier Specifications .....	1- 14
1.2.3.7 Transmission/Reception Settings .....	1- 15
1.2.3.8 Box Settings .....	1- 16
1.2.3.9 Printer Settings .....	1- 16
1.2.3.10 Address Book Settings .....	1- 18
1.2.3.11 Voice Guide Settings .....	1- 19
1.2.4 Maintenance by the User .....	1- 19
1.2.4.1 Cleaning .....	1- 19
1.2.4.2 Checks .....	1- 20
1.2.5 Safety .....	1- 21
1.2.5.1 Safety of the Machine's Laser Unit .....	1- 21
1.2.5.2 CDRH Regulations .....	1- 21
1.2.5.3 Handling the Machine's Laser Unit .....	1- 22
1.2.5.4 Safety of Toner .....	1- 22
1.2.6 Product Specifications .....	1- 22
1.2.6.1 Product Specifications .....	1- 22
1.2.7 Function List .....	1- 24
1.2.7.1 Paper Types .....	1- 24
1.2.7.2 Printing Speed .....	1- 24
1.2.7.3 Paper Types/Printing Speed (K paper) .....	1- 25

## Chapter 2 Installation

2.1 Making Pre-Checks .....	2- 1
2.1.1 Selecting the installation space .....	2- 1
2.1.2 Combination Table of Accessories .....	2- 2
2.1.3 Checking the Contents .....	2- 3
2.2 Unpacking and Installation .....	2- 5
2.2.1 Unpacking and installation procedure .....	2- 5
2.2.2 Unpacking .....	2- 5
2.2.3 Installation of Scanner .....	2- 7
2.2.4 Installation of Fixing Assembly .....	2- 7
2.2.5 Checking of Charging Assembly and Dustproof Glass .....	2- 8
2.2.6 Installation of Developing Assembly .....	2- 9

2.2.7 Installation of Pickup Assembly .....	2- 10
2.2.8 Attaching Deck Pressure Plate .....	2- 11
2.2.9 Setting Toner Container .....	2- 11
2.2.10 Connecting the Cable.....	2- 12
2.2.11 Checking the Environment Switch .....	2- 12
2.2.12 Attaching the Label .....	2- 13
2.2.13 Connecting the Power Cord .....	2- 13
2.2.14 Turning On the Main Power Switch.....	2- 14
2.2.15 Toner Stirring .....	2- 14
2.2.16 Media Cassette Settings .....	2- 14
2.2.17 Index Paper Attachment.....	2- 14
2.2.18 Changing the Media Size of the Front Deck (Left/Right).....	2- 15
2.2.19 Image/Operation Check in User Mode.....	2- 15
2.2.20 Adjustment of Image Left End Margin.....	2- 15
2.2.21 Adjustment of image leading edge margin.....	2- 16
2.2.22 Mounting of the Host Machine .....	2- 16
2.3 Checking the Connection to the Network .....	2- 19
2.3.1 Overview .....	2- 19
2.3.2 Checking the Connection to the Network.....	2- 19
2.3.3 Using the Ping Command .....	2- 19
2.3.4 Making a Check Using the Remote Host Address.....	2- 19
2.4 Troubleshooting the Network .....	2- 19
2.4.1 Troubleshooting the Network .....	2- 19
2.4.2 Checking the Connection of the Network Cable .....	2- 19
2.4.3 Making a Check Using a Loopback Address .....	2- 19
2.4.4 Making a Check Using a Local Host Address .....	2- 19
2.5 Relocating the Machine.....	2- 20
2.5.1 Operation for Moving the Machine.....	2- 20
2.6 Installing the Copy Tray.....	2- 20
2.6.1 Confirming the contents .....	2- 20
2.6.2 Power off of the host machine .....	2- 20
2.6.3 Installation procedure.....	2- 20
2.7 Installing the Card Reader.....	2- 22
2.7.1 Notice At Installation .....	2- 22
2.7.2 Confirming the contents .....	2- 22
2.7.3 Power off of the host machine .....	2- 22
2.7.4 Installation procedure.....	2- 22
2.7.5 Installing for imageWARE Accounting Manager .....	2- 24
2.8 Installing the Original Holder .....	2- 24
2.8.1 Checking Contents .....	2- 24
2.8.2 Installation Procedure .....	2- 24
2.8.3 Checking Contents .....	2- 25
2.8.4 Installation Procedure .....	2- 25
2.9 Installing the Reader Heater.....	2- 25
2.9.1 Checking the Contents.....	2- 25
2.9.2 Power off of the host machine .....	2- 25
2.9.3 Installation Procedure .....	2- 26
2.10 Installing the Cassette Heater .....	2- 27
2.10.1 Checking Components.....	2- 27
2.10.2 Power off of the host machine.....	2- 28
2.10.3 Installation Procedure of the Cassette Heater .....	2- 28
2.11 Installing the Deck Heater .....	2- 30
2.11.1 Checking the Parts to Install .....	2- 30
2.11.2 Turning Off the Host Machine .....	2- 31
2.12 Installing the Deck Heater (Large Deck).....	2- 31



---

2.12.1 Checking the Parts to Install .....	2- 31
2.12.2 Turning Off the Host Machine.....	2- 32
2.13 Installing the Voice Guidance Kit .....	2- 32
2.13.1 A point to keep in mind at installation .....	2- 32
2.13.2 Checking the Contents .....	2- 32
2.13.3 Power off of the host machine .....	2- 33
2.13.4 Installation Procedure .....	2- 33
2.14 Installing the Wireless Network Interface Adapter .....	2- 39
2.14.1 Points to Note When Installing.....	2- 39
2.14.2 Checking the Contents .....	2- 39
2.14.3 Power off of the host machine .....	2- 39
2.14.4 Installation Procedure .....	2- 39
2.14.5 Affixing the Label .....	2- 41

### Chapter 3 Basic Operation

3.1 Construction .....	3- 1
3.1.1 Functional Construction.....	3- 1
3.1.2 Wiring Diagram of the Major PCBs.....	3- 1
3.1.3 Controlling the Main Motor (M2) .....	3- 2
3.2 Basic Sequence.....	3- 3
3.2.1 Basic Sequence of Operation (at power-on; 30-sec start-up mode) .....	3- 3
3.2.2 Basic Sequence of Operation (at power-on; low-temperature start-up mode) .....	3- 3
3.2.3 Basic Sequence of Operation (at power-on; high-humidity start-up mode).....	3- 4
3.2.4 Basic Sequence of Operation (at time of copying/printing) .....	3- 5

### Chapter 4 Main Controller

4.1 Construction .....	4- 1
4.1.1 Construction and Mechanisms .....	4- 1
4.2 Construction of the Electrical Circuitry.....	4- 1
4.2.1 Main Controller PCB.....	4- 1
4.2.2 HDD.....	4- 2
4.3 Start-Up Sequence .....	4- 4
4.3.1 Overview.....	4- 4
4.3.2 Start-Up Sequence .....	4- 4
4.4 Shut-Down Sequence.....	4- 6
4.4.1 Overview.....	4- 6
4.4.2 Flow of Operation .....	4- 6
4.5 Image Processing.....	4- 6
4.5.1 Overview of the Image Flow .....	4- 6
4.5.2 Construction of the Image Processing Module.....	4- 7
4.5.3 Reader Unit Input Image Processing.....	4- 7
4.5.4 Compression/ Extension/ Editing Block.....	4- 8
4.5.5 Printer unit Output Image Processing.....	4- 8
4.6 Flow of Image Data .....	4- 9
4.6.1 Flow of Image Data According to Copy Functions .....	4- 9
4.6.2 Flow of Image Data for the Box Function .....	4- 9
4.6.3 Flow of Image Data for the SEND Function .....	4- 10
4.6.4 Flow of Image Data for the Fax Transmission.....	4- 10
4.6.5 Flow of Image Data for the Fax Reception Function .....	4- 11
4.6.6 Flow of Image Data for the PDL Function .....	4- 12
4.7 Parts Replacement Procedure .....	4- 13
4.7.1 Main Controller Box .....	4- 13
4.7.1.1 Before Removing the Main Controller Box.....	4- 13
4.7.1.2 Removing the Main Controller Box .....	4- 13

4.7.2 Main Controller PCB .....	4- 13
4.7.2.1 Before Removing the Main Controller PCB .....	4- 13
4.7.2.2 Removing the Main Controller PCB .....	4- 13
4.7.2.3 When Replacing the Main Controller PCB .....	4- 14
4.7.3 SDRAM .....	4- 14
4.7.3.1 Before Removing the SDRAM .....	4- 14
4.7.3.2 Removing the SDRAM .....	4- 14
4.7.4 Boot ROM .....	4- 14
4.7.4.1 Before Removing the Boot ROM .....	4- 14
4.7.4.2 Removing the Boot ROM .....	4- 14
4.7.5 HDD .....	4- 15
4.7.5.1 Before Removing HDD .....	4- 15
4.7.5.2 Removing the HDD .....	4- 15
4.7.5.3 After Replacing the HDD .....	4- 15
4.7.6 Video PCB .....	4- 15
4.7.6.1 Before Removing the Video PCB .....	4- 15
4.7.6.2 Removing the Video PCB .....	4- 15
4.7.7 Controller Fan .....	4- 16
4.7.7.1 Before Removing the Controller Cooling Fan .....	4- 16
4.7.7.2 Removing the Controller Cooling Fan .....	4- 16

## Chapter 5 Original Exposure System

5.1 Construction .....	5- 1
5.1.1 Specifications, Controls, and Functions .....	5- 1
5.1.2 Major Components .....	5- 1
5.1.3 Construction of the Control System .....	5- 2
5.1.4 Reader Controller PCB .....	5- 3
5.2 Basic Sequence .....	5- 4
5.2.1 Basic Sequence of Operations .....	5- 4
5.2.2 Basic Sequence of Operation in Response to a Press on the Start Key .....	5- 5
5.3 Various Control .....	5- 5
5.3.1 Controlling the Scanner Drive System .....	5- 5
5.3.1.1 Overview .....	5- 5
5.3.1.2 Controlling the Scanner Motor .....	5- 6
5.3.2 Enlargement/Reduction .....	5- 7
5.3.2.1 Changing the Magnification in Main Scanning Direction .....	5- 7
5.3.2.2 Changing the Magnification in Sub Scanning Direction .....	5- 7
5.3.3 Controlling the Scanning Lamp .....	5- 8
5.3.3.1 Overview .....	5- 8
5.3.3.2 Scanning Lamp .....	5- 8
5.3.3.3 Controlling the Activation .....	5- 9
5.3.4 Detecting the Size of Originals .....	5- 9
5.3.4.1 Overview .....	5- 9
5.3.4.2 Points of Measurement Used for Original Size Identification .....	5- 9
5.3.4.3 Overview of Operation .....	5- 10
5.3.5 Dirt Sensor Control .....	5- 12
5.3.5.1 Dust Detection in Stream Reading Mode .....	5- 12
5.3.5.2 White Plate Dust Detection Control .....	5- 13
5.3.6 Image Processing .....	5- 14
5.3.6.1 Overview .....	5- 14
5.3.6.2 CCD Drive .....	5- 15
5.3.6.3 CCD Output Gain Correction, Offset Correction .....	5- 15
5.3.6.4 CCD Output A/D Conversion .....	5- 15
5.3.6.5 Outline of Shading Correction .....	5- 15
5.3.6.6 Shading Adjustment .....	5- 16
5.3.6.7 Shading Correction .....	5- 16
5.4 Parts Replacement Procedure .....	5- 17
5.4.1 CCD Unit .....	5- 17

5.4.1.1 Before Removing the CCD Unit .....	5- 17
5.4.1.2 Removing the CCD Unit.....	5- 17
5.4.1.3 When Replacing the CCD Unit .....	5- 17
5.4.2 Copyboard glass.....	5- 18
5.4.2.1 Removing the Copyboard Glass .....	5- 18
5.4.2.2 When Replacing the Copyboard Glass .....	5- 18
5.4.3 Scanning Lamp.....	5- 18
5.4.3.1 Before Removing the Scanning Lamp .....	5- 18
5.4.3.2 Removing the Scanning Lamp .....	5- 18
5.4.3.3 When Replacing the Scanning Lamp.....	5- 19
5.4.4 Reader Controller PCB.....	5- 19
5.4.4.1 Before Removing the Reader Controller PCB .....	5- 19
5.4.4.2 Removing the Reader Controller PCB .....	5- 19
5.4.4.3 After Replacing the Reader Controller PCB.....	5- 20
5.4.5 Interface PCB .....	5- 20
5.4.5.1 Before Removing the Interface PCB .....	5- 20
5.4.5.2 Removing the Interface PCB .....	5- 20
5.4.6 Memory PCB .....	5- 21
5.4.6.1 Before Removing the Memory PCB.....	5- 21
5.4.6.2 Removing the memory PCB .....	5- 21
5.4.7 Inverter PCB .....	5- 21
5.4.7.1 Before removing the inverter PCB .....	5- 21
5.4.7.2 Removing the Inverter PCB .....	5- 21
5.4.7.3 After Replacing the Inverter PCB.....	5- 22
5.4.8 Scanner Motor .....	5- 22
5.4.8.1 Before Removing the Scanner Motor.....	5- 22
5.4.8.2 Removing the Scanner Motor .....	5- 22
5.4.8.3 Mounting the Scanner Motor.....	5- 23
5.4.9 ADF Open/Close Sensor .....	5- 23
5.4.9.1 Before Removing the ADF Open/Close Sensor.....	5- 23
5.4.9.2 Removing the ADF Open/Close Sensor .....	5- 23
5.4.10 Scanner HP Sensor .....	5- 23
5.4.10.1 Before Removing the Scanner HP Sensor.....	5- 23
5.4.10.2 Removing the Mirror Base HP Sensor .....	5- 23
5.4.11 Original Size Sensor .....	5- 24
5.4.11.1 Before Removing the Original Size Sensor.....	5- 24
5.4.11.2 Removing the original size sensor .....	5- 24
5.4.12 Cooling Fan .....	5- 25
5.4.12.1 Before Removing the Cooling Fan .....	5- 25
5.4.12.2 Removing the Cooling Fan.....	5- 25
5.4.13 Scanner Drive Cable.....	5- 25
5.4.13.1 Outline .....	5- 25
5.4.13.2 Before Removing the Scanner Drive Cable .....	5- 25
5.4.13.3 Removing the Scanner Drive Cable.....	5- 25
5.4.13.4 Fitting the Scanner Drive Cable .....	5- 28
5.4.13.5 Adjusting the Position of the No. 1/No. 2 Mirror Base.....	5- 28
5.4.14 Waste Toner Box Holder .....	5- 29
5.4.14.1 Before Removing the Collecting Toner Bottle Holder .....	5- 29
5.4.14.2 Removing the Collecting Toner Bottle Holder .....	5- 29

## Chapter 6 Laser Exposure

6.1 Construction .....	6- 1
6.1.1 Overview.....	6- 1
6.1.2 Major Components .....	6- 1
6.2 Basic Sequence.....	6- 2
6.2.1 Basic Sequence of Operation (laser exposure).....	6- 2
6.3 Various Controls .....	6- 2
6.3.1 Controlling the Laser Activation Timing .....	6- 2

6.3.1.1	Generating the Sync Signal .....	6-2
6.3.1.2	Flow of the Sync Signal .....	6-2
6.3.2	Controlling the Intensity of Laser Light.....	6-2
6.3.2.1	Controlling the Laser Intensity .....	6-2
6.3.2.2	APC Control.....	6-3
6.3.3	Controlling the Laser Scanner Motor .....	6-4
6.3.3.1	Controlling the Laser Scanner Motor .....	6-4
6.4	Parts Replacement Procedure .....	6-5
6.4.1	Laser Scanner Unit .....	6-5
6.4.1.1	Removing the Laser Scanner Unit.....	6-5
6.4.1.2	When Replacing the Laser Scanner Unit.....	6-5

## Chapter 7 Image Formation

7.1	Construction .....	7- 1
7.1.1	Overview .....	7- 1
7.1.2	Major Components.....	7- 1
7.2	Image Formation Process .....	7- 1
7.2.1	Overview .....	7- 1
7.3	Basic Sequence .....	7- 2
7.3.1	At Power-On .....	7- 2
7.3.2	At Time of Printing .....	7- 3
7.4	Potential Control .....	7- 3
7.4.1	Overview .....	7- 3
7.4.2	Copier/Printer Potential Control .....	7- 3
7.4.3	Determining the Primary Current .....	7- 6
7.4.4	Determining the Laser Output.....	7- 6
7.4.5	Determining the Developing Bias.....	7- 6
7.4.6	APC Correction .....	7- 7
7.4.7	Adjusting the Density in Various Modes .....	7- 7
7.5	Charging Mechanism .....	7- 8
7.5.1	Controlling Pre-Exposure LED.....	7- 8
7.5.1.1	Pre-Exposure LED Control .....	7- 8
7.5.2	Primary Charging Mechanism.....	7- 9
7.5.2.1	Overview .....	7- 9
7.5.2.2	Primary Charging Assembly Cleaning Mechanism.....	7- 9
7.5.2.3	Others .....	7- 10
7.5.3	Dust-Collecting Roller Bias .....	7- 10
7.5.3.1	Overview .....	7- 10
7.5.4	Pre-Transfer Charging Mechanism.....	7- 11
7.5.4.1	Overview .....	7- 11
7.5.4.2	Controlling the Output to Suit the Environment (fuzzy control) .....	7- 11
7.5.4.3	Pre-Transfer Charging Assembly Cleaning Mechanism .....	7- 12
7.5.4.4	Others .....	7- 12
7.6	Drum Cleaner Unit.....	7- 12
7.6.1	Overview .....	7- 12
7.6.2	Detecting the State (full) of the Collecting Toner Case.....	7- 13
7.6.3	Drum/Separation Claw Bias Control .....	7- 14
7.7	Developing Assembly .....	7- 14
7.7.1	Controlling the Developing Assembly Drive.....	7- 14
7.7.2	Controlling the Developing Bias.....	7- 14
7.7.3	Detecting the Toner Level and Controlling Toner Supply .....	7- 15
7.8	Transfer Mechanism.....	7- 16
7.8.1	Transfer Charging Mechanism.....	7- 16
7.8.1.1	Overview .....	7- 16
7.8.1.2	Controlling the Output to Suit the Environment (fuzzy control) .....	7- 16
7.8.1.3	Transfer Charging Assembly Cleaning Mechanism.....	7- 17

---

7.8.1.4 Others .....	7- 17
<b>7.9 Separation Mechanism .....</b>	<b>7- 18</b>
7.9.1 Separation Charging Mechanism .....	7- 18
7.9.1.1 Overview .....	7- 18
7.9.1.2 Correcting the Output to Suit the Environment and the Drum Surface Potential .....	7- 18
7.9.1.3 Others .....	7- 19
<b>7.10 Parts Replacement Procedure .....</b>	<b>7- 20</b>
7.10.1 Process Unit .....	7- 20
7.10.1.1 Before Removing Process Unit .....	7- 20
7.10.1.2 Removing Process Unit .....	7- 20
7.10.1.3 Mounting Process Unit .....	7- 20
7.10.2 Pre-Exposure Lamp .....	7- 21
7.10.2.1 Before Removing Pre-Exposure Lamp .....	7- 21
7.10.2.2 Removing Pre-Exposure Lamp .....	7- 21
7.10.2.3 Cleaning Primary Toner Blocking Sheet .....	7- 21
7.10.3 Primary Charging Assembly .....	7- 21
7.10.3.1 Before Removing Primary Charging Assembly .....	7- 21
7.10.3.2 Removing Primary Charging Assembly .....	7- 21
7.10.4 Pre-Transfer Charging Assembly .....	7- 22
7.10.4.1 Before Removing Pre-Transfer Charging Assembly .....	7- 22
7.10.4.2 Removing Pre-Transfer Charging Assembly .....	7- 22
7.10.5 Photosensitive Drum .....	7- 22
7.10.5.1 Points to Note When Handling Photosensitive Drum .....	7- 22
7.10.5.2 Before Removing Photosensitive Drum .....	7- 22
7.10.5.3 Removing Photosensitive Drum .....	7- 22
7.10.5.4 Cleaning Photosensitive Drum .....	7- 23
7.10.6 Drum Motor .....	7- 23
7.10.6.1 Before Removing Drum Motor .....	7- 23
7.10.6.2 Removing Drum Motor .....	7- 23
7.10.7 Photosensitive Drum Heater .....	7- 24
7.10.7.1 Points to Note When Handling Photosensitive Drum .....	7- 24
7.10.7.2 Before Removing Photosensitive Drum Heater .....	7- 24
7.10.7.3 Removing Drum Heater .....	7- 24
7.10.7.4 Points to Note When Mounting Drum Heater .....	7- 24
7.10.8 Cleaning Blade .....	7- 24
7.10.8.1 Configuration .....	7- 24
7.10.8.2 Before Removing Cleaning Blade .....	7- 24
7.10.8.3 Removing Cleaning Blade .....	7- 24
7.10.8.4 Mounting Cleaning Blade .....	7- 25
7.10.9 Side Seal .....	7- 25
7.10.9.1 Before Removing Side Seal .....	7- 25
7.10.9.2 Removing Side Seal .....	7- 26
7.10.10 Cleaner Scraper .....	7- 26
7.10.10.1 Before Cleaning Cleaner Scraper .....	7- 26
7.10.10.2 Cleaning Cleaner Scraper .....	7- 26
7.10.11 Hopper Assembly .....	7- 26
7.10.11.1 Before Removing Hopper Assembly .....	7- 26
7.10.11.2 Removing Hopper Assembly .....	7- 26
7.10.12 Hopper Supply Motor .....	7- 27
7.10.12.1 Before Removing Toner Supply Motor .....	7- 27
7.10.12.2 Removing Toner Supply Motor .....	7- 27
7.10.13 Hopper Strring Motor .....	7- 27
7.10.13.1 Before Removing Hopper Stirring Motor .....	7- 27
7.10.13.2 Removing Hopper Stirring Motor .....	7- 27
7.10.14 Developing Assembly .....	7- 28
7.10.14.1 Removing Developing Assembly .....	7- 28
7.10.14.2 Cleaning Developing Toner Blocking Sheet .....	7- 28
7.10.15 Developing Cylinder .....	7- 29
7.10.15.1 Before Removing Developing Cylinder .....	7- 29
7.10.15.2 Removing Developing Cylinder .....	7- 29

7.10.16 Developing Blade .....	7- 29
7.10.16.1 Before Removing Developing Blade .....	7- 29
7.10.16.2 Removing Developing Blade .....	7- 29
7.10.16.3 Mounting Developing Blade .....	7- 29
7.10.17 Transfer/Separation Charging Assembly .....	7- 30
7.10.17.1 Removing Transfer/Separation Charging Assembly .....	7- 30
7.10.17.2 Mounting Transfer/Separation Charging Assembly .....	7- 30
7.10.18 Separation Claw/Separation Claw Drive Assembly.....	7- 30
7.10.18.1 Before Removing Separation Claw Holder .....	7- 30
7.10.18.2 Removing Separation Claw Holder .....	7- 30
7.10.19 Potential Sensor Unit.....	7- 31
7.10.19.1 Outline .....	7- 31
7.10.19.2 Before Removing Potential Sensor Unit .....	7- 31
7.10.19.3 Removing Potential Sensor Unit .....	7- 31
7.10.20 Charging Wire .....	7- 31
7.10.20.1 Outline .....	7- 31
7.10.20.2 Routing Charging Wire .....	7- 31
7.10.20.3 Routing Grid for Primary Charging Assembly .....	7- 32
7.10.20.4 Adjusting Height of Charging Wire .....	7- 32

## Chapter 8 Pickup/Feeding System

8.1 Construction .....	8- 1
8.1.1 Specifications and construction .....	8- 1
8.1.2 Arrangement of Rollers and Sensors.....	8- 1
8.1.3 Outline of the Pickup Control System .....	8- 3
8.1.4 Outline of the Pickup Assembly Motor Control System .....	8- 5
8.2 Basic Sequence .....	8- 6
8.2.1 Pickup from the Right Deck .....	8- 6
8.2.2 Pickup from the Cassette 3.....	8- 7
8.2.3 Pickup Retry Operation.....	8- 8
8.3 Detecting Jams.....	8- 8
8.3.1 Jam Detection Outline.....	8- 8
8.3.1.1 Outline.....	8- 8
8.3.1.2 Jam History .....	8- 10
8.3.2 Delay Jams .....	8- 10
8.3.2.1 Cassette Pickup Assembly (right deck, left deck, cassette 3/4).....	8- 10
8.3.2.2 Other Delay Jam .....	8- 10
8.3.3 Stationary Jams .....	8- 11
8.3.3.1 Common Delay Jams.....	8- 11
8.3.3.2 Power-On Stationary Jam.....	8- 12
8.4 Cassette Pick-Up Unit .....	8- 12
8.4.1 Lifter Operation (cassette 3/4) .....	8- 12
8.4.2 Detecting the Presence/Absence of Paper .....	8- 13
8.4.3 Outline of the Paper Level Detection Mechanism.....	8- 14
8.4.4 Paper Level Detection (cassette 3/4).....	8- 14
8.4.5 Identifying the Size of Paper (cassette 3/4) .....	8- 14
8.4.6 Markings on the Width Guide Rail .....	8- 15
8.4.7 Paper Size .....	8- 15
8.5 Manual Feed Pickup Unit .....	8- 17
8.5.1 Pickup Operation .....	8- 17
8.5.2 Detecting the Size of Paper in the Manual Feed Tray .....	8- 18
8.6 Deck .....	8- 19
8.6.1 Lifter Operation (right/left deck) .....	8- 19
8.6.2 Lifter Limiter (right/left deck) Control Circuit.....	8- 19
8.6.3 Detecting the Presence/Absence of Paper .....	8- 20
8.6.4 Outline of Paper Level Detection .....	8- 20

---

8.6.5 Paper Level Detection Operation (right/left deck).....	8- 21
8.6.6 Identifying the Size of Paper (right/left deck).....	8- 21
8.7 Registration Unit.....	8- 21
8.7.1 Outline.....	8- 21
8.7.2 Control System.....	8- 22
8.8 Duplex Feeding Unit.....	8- 22
8.8.1 Moving the Paper to the Reversing Assembly After Printing on the 1st Side.....	8- 22
8.8.2 Moving the Paper to the Duplexing Feed Assembly From the Reversing Assembly.....	8- 22
8.8.3 Outline.....	8- 23
8.8.4 Sequence of Printing Operation.....	8- 23
8.8.5 Outline of Through-Path Operation.....	8- 24
8.8.6 Through-Path Operation.....	8- 24
8.8.7 Outline of Horizontal Registration Position.....	8- 28
8.8.8 Horizontal Registration Position Detection Operation.....	8- 28
8.9 Delivery.....	8- 29
8.9.1 Reversal Delivery Operation.....	8- 29
8.10 Cassette Heater.....	8- 30
8.10.1 Timing of the Cassette Heater Supplied with Power.....	8- 30
8.11 Parts Replacement Procedure.....	8- 31
8.11.1 Pickup Roller.....	8- 31
8.11.1.1 Before Removing the Pickup Roller.....	8- 31
8.11.1.2 Removing the Pickup Roller.....	8- 31
8.11.1.3 Points to Note When Mounting the Pickup Roller.....	8- 31
8.11.2 Cassette Pickup Assembly.....	8- 31
8.11.2.1 Removing the Cassette 3/4 Pickup Assembly.....	8- 31
8.11.3 Cassette Pickup Motor.....	8- 31
8.11.3.1 Before Removing the Cassette 3/4 Pickup Motor.....	8- 31
8.11.3.2 Removing the Cassette 3/4 Pickup Motor.....	8- 31
8.11.4 Cassette Lifter Motor.....	8- 32
8.11.4.1 Removing the Cassette 3 Lifter Motor M20.....	8- 32
8.11.4.2 Removing the Cassette 4 Lifter Motor M21.....	8- 32
8.11.4.3 Adjusting the Position of the Lifter Motor M20/M21 of the Cassette 3/4.....	8- 33
8.11.5 Left Deck Lifter Motor.....	8- 33
8.11.5.1 Before Removing the Left Deck Lifter Motor.....	8- 33
8.11.5.2 Removing the Left Deck Lifter Motor.....	8- 33
8.11.6 Right Deck Lifter Motor.....	8- 34
8.11.6.1 Before Removing the Right Deck Lifter Motor.....	8- 34
8.11.6.2 Removing the Right Deck Lifter Motor.....	8- 34
8.11.7 Right Deck Pickup Assembly.....	8- 35
8.11.7.1 Removing the Right Deck Pickup Assembly.....	8- 35
8.11.8 Left Deck Pickup Assembly.....	8- 35
8.11.8.1 Removing the Left Deck Pickup Assembly.....	8- 35
8.11.9 Left Deck Pickup Motor.....	8- 36
8.11.9.1 Before Removing the Left Deck Pickup Motor.....	8- 36
8.11.9.2 Removing the Left Deck Pickup Motor.....	8- 36
8.11.10 Right Deck Pickup Motor.....	8- 36
8.11.10.1 Before Removing the Right Deck Pickup Motor.....	8- 36
8.11.10.2 Removing the Right Deck Pickup Motor.....	8- 36
8.11.11 Left Deck Pickup Sensor.....	8- 36
8.11.11.1 Before Removing the Left Deck Feeding Sensor.....	8- 36
8.11.11.2 Removing the Left Deck Feeding Sensor.....	8- 36
8.11.12 Left Deck Pickup Solenoid.....	8- 36
8.11.12.1 Before Removing the Left Deck Pickup Solenoid.....	8- 36
8.11.12.2 Removing the Left Deck Pickup Solenoid.....	8- 37
8.11.12.3 Adjusting the Position of the Left Deck Pickup Solenoid.....	8- 37
8.11.13 Manual Feed Pull-Out Roller Unit.....	8- 37
8.11.13.1 Removing the Manual Feeding Pickup Roller Unit.....	8- 37
8.11.14 Manual Feed Pull-Out Roller.....	8- 37

8.11.14.1 Before Removing the Manual Feeding Pickup Roller.....	8- 37
8.11.14.2 Removing the Manual Feeding Pickup Roller .....	8- 37
8.11.15 Manual Feed Roller.....	8- 38
8.11.15.1 Before Removing the Manual Feeding Roller .....	8- 38
8.11.15.2 Removing the Manual Feeding Roller.....	8- 38
8.11.16 Manual Separation Roller.....	8- 38
8.11.16.1 Before Removing the Manual Separation Roller .....	8- 38
8.11.16.2 Removing the Manual Separation Roller.....	8- 38
8.11.16.3 Adjusting the Pressure of the Manual Separation Roller.....	8- 38
8.11.17 Manual Feed Tray paper sensor .....	8- 39
8.11.17.1 Removing the Manual Feeding Tray Sensor.....	8- 39
8.11.18 Registration Roller.....	8- 39
8.11.18.1 Before Removing the Registration Roller .....	8- 39
8.11.18.2 Removing the Registration Roller.....	8- 39
8.11.19 Pre-Registration Roller .....	8- 40
8.11.19.1 Before Removing the Registration Lower Roller .....	8- 40
8.11.19.2 Removing the Registration Lower Roller.....	8- 40
8.11.20 Pre-Registration Motor .....	8- 41
8.11.20.1 Before Removing the Registration Front Motor.....	8- 41
8.11.20.2 Removing the Registration Front Motor .....	8- 41
8.11.21 Registration Motor .....	8- 41
8.11.21.1 Before Removing the Horizontal Registration Motor .....	8- 41
8.11.21.2 Removing the Horizontal Registration Motor.....	8- 41
8.11.22 Registration Sensor.....	8- 42
8.11.22.1 Before Removing the Horizontal Registration Sensor.....	8- 42
8.11.22.2 Removing the Horizontal Registration Sensor .....	8- 42
8.11.23 Registration Clutch.....	8- 43
8.11.23.1 Before Removing the Registration Clutch .....	8- 43
8.11.23.2 Removing the Registration Clutch.....	8- 43
8.11.24 Registration Brake Clutch.....	8- 43
8.11.24.1 Before Removing the Registration Brake .....	8- 43
8.11.24.2 Removing the Registration Brake.....	8- 43
8.11.25 Feeding Roller .....	8- 43
8.11.25.1 Before Removing the Feeding Roller .....	8- 43
8.11.25.2 Removing the Feeding Roller.....	8- 43
8.11.25.3 The Points to Mount the Feeding Roller.....	8- 44
8.11.26 Vertical Path Roller.....	8- 44
8.11.26.1 Before Removing the Vertical Path Roller .....	8- 44
8.11.26.2 Removing the Vertical Path Roller .....	8- 44
8.11.26.3 Removing the Vertical Path Roller 2/3 .....	8- 44
8.11.27 Vertical Path Motor.....	8- 44
8.11.27.1 Before Removing the Vertical Path Upper Motor .....	8- 44
8.11.27.2 Removing the Vertical Path Upper Motor.....	8- 45
8.11.28 Vertical Path Duplex Motor.....	8- 45
8.11.28.1 Before Removing the Vertical Path Duplex Motor.....	8- 45
8.11.28.2 Removing the Vertical Path Duplex Motor .....	8- 45
8.11.29 Vertical Path Lower Motor .....	8- 45
8.11.29.1 Before Removing the Vertical Path Lower Motor .....	8- 45
8.11.29.2 Removing the Vertical Path Lower Motor.....	8- 45
8.11.30 Reversing Motor.....	8- 45
8.11.30.1 Before Removing the Reversing Motor .....	8- 45
8.11.30.2 Removing the Reversing Motor.....	8- 46
8.11.30.3 Mounting the Reversing Motor .....	8- 46
8.11.31 Fixing Feeding Unit Releasing Lever Sensor.....	8- 46
8.11.31.1 Before Removing the Fixing Feeding Unit Release Lever Sensor .....	8- 46
8.11.31.2 Removing the Fixing Feeding Unit Release Lever Sensor.....	8- 46
8.11.32 Reversing Sensor.....	8- 46
8.11.32.1 Before Removing the Reversing Sensor 1 .....	8- 46
8.11.32.2 Removing the Reversing Sensor 1.....	8- 46
8.11.32.3 Before Removing the Reversing Sensor 2 .....	8- 47



8.11.32.4 Removing the Reversing Sensor 2.....	8- 47
8.11.33 Reversing Unit .....	8- 47
8.11.33.1 Before Removing the Reversing Flapper Solenoid .....	8- 47
8.11.33.2 Removing the Reversing Flapper Solenoid .....	8- 47
8.11.33.3 Mounting the Reversing Flapper Solenoid .....	8- 47
8.11.34 Feeding Belt.....	8- 48
8.11.34.1 Before Removing the feeding belt .....	8- 48
8.11.34.2 Removing the feeding belt .....	8- 48
8.11.35 Duplexing Unit.....	8- 49
8.11.35.1 Before Removing the Duplex Feeding Unit .....	8- 49
8.11.35.2 Removing the Duplex Feeding Unit.....	8- 49
8.11.36 Duplex Feed Motor .....	8- 49
8.11.36.1 Before Removing the Duplex Feeding Left Motor .....	8- 49
8.11.36.2 Removing the Duplex Feeding Left Motor .....	8- 49
8.11.36.3 Before Removing the Duplex Feeding Right Motor .....	8- 49
8.11.36.4 Removing the Duplex Feeding Right Motor .....	8- 49
8.11.37 Duplex Feed Sensor .....	8- 49
8.11.37.1 Before Removing the Duplex Pre-Registration Sensor .....	8- 49
8.11.37.2 Removing the Duplex Pre-Registration Sensor.....	8- 49
8.11.38 Separation Roller .....	8- 50
8.11.38.1 Before Removing the Separation Roller.....	8- 50
8.11.38.2 Removing the Separation Roller .....	8- 50
8.11.38.3 Points to Note When Mounting the Separation Roller.....	8- 50
8.11.38.4 Adjusting the Pressure of the Deck/Cassette Separation Roller.....	8- 51

## Chapter 9 Fixing System

9.1 Construction .....	9- 1
9.1.1 Specifications, Control Mechanisms, and Functions .....	9- 1
9.1.2 Major Components .....	9- 1
9.1.3 IH Fixing Method (outline) .....	9- 3
9.1.4 Limiting the Rise in Temperature at the Roller Edges by Use of a Flux blocking Plate (shutter) .....	9- 3
9.2 Basic Sequence.....	9- 4
9.2.1 Outline .....	9- 4
9.2.2 30-Sec Start-Up Mode .....	9- 4
9.2.3 Low-Temperature Environment Start-Up Mode.....	9- 5
9.2.4 High-Humidity Environment Start-Up Mode .....	9- 5
9.2.5 Recovery Mode .....	9- 6
9.2.6 Standby Mode .....	9- 6
9.2.7 Power Save Mode .....	9- 7
9.2.8 Sleep Mode .....	9- 7
9.2.9 Copying/Printing Mode .....	9- 7
9.2.10 Down Sequence .....	9- 8
9.2.11 Enhanced Fixing Mode .....	9- 8
9.2.12 Heavy Paper Mode .....	9- 9
9.2.13 Transparency Mode.....	9- 9
9.2.14 Bond Paper Mode.....	9- 9
9.3 Various Control Mechanisms.....	9- 10
9.3.1 Fixing Drive System.....	9- 10
9.3.1.1 Controlling the Drive of the Fixing Roller .....	9- 10
9.3.1.2 Controlling the Drive of the Fixing Inlet Guide .....	9- 10
9.3.1.3 Controlling the Reciprocating Movement of the Thermistor .....	9- 11
9.3.1.4 Controlling the Reciprocating Mechanism of the Upper Separation Claw .....	9- 11
9.3.1.5 Controlling the Drive of the Shutter .....	9- 12
9.3.1.6 Controlling the Shutter Position .....	9- 13
9.3.2 Cleaning .....	9- 14
9.3.2.1 Controlling the Drive of the Cleaning Web.....	9- 14
9.3.2.2 Controlling the Mechanism Used to Detect the Remaining Length of the Cleaning Web.....	9- 15

9.3.3 Detecting the Passage of Paper .....	9- 16
9.3.3.1 Preventing Wrapping of Paper .....	9- 16
9.4 Protective Functions .....	9- 17
9.4.1 Detecting an Error Using the Thermistor .....	9- 17
9.4.2 Detecting an Error Using the Thermal Switch .....	9- 17
9.4.3 Errors .....	9- 17
9.5 Parts Replacement Procedure .....	9- 19
9.5.1 Fixing/Feeding Assembly .....	9- 19
9.5.1.1 Before Removing the Fixing/Feeding unit .....	9- 19
9.5.1.2 Removing the Fixing/Feeding unit .....	9- 19
9.5.2 Fixing Unit .....	9- 20
9.5.2.1 Before Removing the Fixing Upper Unit .....	9- 20
9.5.2.2 Removing the Fixing Upper Unit .....	9- 20
9.5.3 Pressure Roller .....	9- 20
9.5.3.1 Before Removing the Pressure Roller .....	9- 20
9.5.3.2 Removing the Pressure Roller .....	9- 20
9.5.4 Upper Fixing Roller .....	9- 21
9.5.4.1 Before Removing the Fixing Roller .....	9- 21
9.5.4.2 Removing the Fixing Roller .....	9- 21
9.5.4.3 Points to Note When Mounting the Fixing Roller .....	9- 23
9.5.4.4 Applying Grease After Replacing the Fixing Roller .....	9- 24
9.5.4.5 Adjusting the Nip Width .....	9- 25
9.5.5 External Delivery Roller .....	9- 25
9.5.5.1 Before Removing the External Delivery Roller .....	9- 25
9.5.5.2 Removing the External Delivery Roller .....	9- 25
9.5.6 Internal Delivery Roller .....	9- 26
9.5.6.1 Before Removing the Internal Delivery Roller .....	9- 26
9.5.6.2 Removing the Internal Delivery Roller .....	9- 26
9.5.6.3 Points to Note When Mounting the Internal Delivery Roller .....	9- 27
9.5.7 Main Thermistor .....	9- 27
9.5.7.1 Before Removing the Main Thermistor/Shutter Thermistor .....	9- 27
9.5.7.2 Removing the Main Thermistor/Shutter Thermistor .....	9- 27
9.5.7.3 Points to Note When Mounting the Main Thermistor/Shutter Thermistor .....	9- 28
9.5.8 Sub Thermistor .....	9- 28
9.5.8.1 Before Removing the Sub Thermistor .....	9- 28
9.5.8.2 Removing the Sub Thermistor .....	9- 29
9.5.8.3 Points to Note When Mounting the Sub Thermistor .....	9- 29
9.5.9 Thermal Switch .....	9- 29
9.5.9.1 Before Removing the Thermal Switch .....	9- 29
9.5.9.2 Removing the Thermal Switch .....	9- 30
9.5.10 Fixing Heater .....	9- 30
9.5.10.1 Before Removing the Fixing Heater Unit .....	9- 30
9.5.10.2 Removing the Fixing Heater Unit .....	9- 30
9.5.11 Fixing Cleaning Belt .....	9- 32
9.5.11.1 Before Removing the Fixing Web .....	9- 32
9.5.11.2 Removing the Fixing Web .....	9- 32
9.5.11.3 Cleaning the fixing oil dish and the fixing cleaning belt guide .....	9- 32
9.5.11.4 Mounting the Fixing Web .....	9- 32
9.5.11.5 After Replacing the Fixing Web .....	9- 33
9.5.12 Fixing Jam Sensor .....	9- 33
9.5.12.1 Before Removing the Delivery Jam Sensor .....	9- 33
9.5.12.2 Removing the Delivery Jam Sensor .....	9- 33
9.5.13 Claw Jam Sensor .....	9- 33
9.5.13.1 Before Removing the Claw Jam Sensor .....	9- 33
9.5.13.2 Removing the Claw Jam Sensor .....	9- 33
9.5.14 External Delivery Sensor .....	9- 34
9.5.14.1 Before Removing the External Delivery Sensor .....	9- 34
9.5.14.2 Removing the External Delivery Sensor .....	9- 34
9.5.15 Internal Delivery Sensor .....	9- 34

9.5.15.1 Before Removing the Internal Delivery Sensor .....	9- 34
9.5.15.2 Removing the Internal Delivery Sensor .....	9- 34
9.5.16 Fixing Inlet Sensor .....	9- 34
9.5.16.1 Before Removing the Fixing Inlet Sensor .....	9- 34
9.5.16.2 Removing the Fixing Inlet Sensor .....	9- 34
9.5.16.3 Adjusting the Fixing Inlet Guide .....	9- 35
9.5.17 Fixing web sensor .....	9- 35
9.5.17.1 Before Removing the Fixing Web Sensor .....	9- 35
9.5.17.2 Removing the Fixing Web Sensor .....	9- 35
9.5.18 Fixing shutter sensor .....	9- 35
9.5.18.1 Before Removing the Shutter Sensor .....	9- 35
9.5.18.2 Removing the Shutter Sensor .....	9- 35
9.5.19 Fixing shutter motor .....	9- 35
9.5.19.1 Before Removing the Shutter Motor .....	9- 35
9.5.19.2 Removing the Shutter Motor .....	9- 35
9.5.20 Fixing Inlet Guide Solenoid .....	9- 36
9.5.20.1 Before Removing the Fixing Inlet Guide Solenoid (SL1) .....	9- 36
9.5.20.2 Removing the Fixing Inlet Guide Solenoid (SL1) .....	9- 36
9.5.20.3 Adjusting the Fixing Inlet Guide Solenoid (SL1) .....	9- 36
9.5.21 Delivery Flapper Solenoid .....	9- 36
9.5.21.1 Before Removing the Delivery Flapper Solenoid (SL5) .....	9- 36
9.5.21.2 Removing the Delivery Flapper Solenoid (SL5) .....	9- 36
9.5.21.3 Points to Note When Mounting the Delivery Flapper Solenoid (SL5) .....	9- 37
9.5.22 Fixing Cleaning Web Solenoid .....	9- 37
9.5.22.1 Before Removing the Fixing Web Solenoid (SL9) .....	9- 37
9.5.22.2 Removing the Fixing Web Solenoid (SL9) .....	9- 37
9.5.22.3 Adjusting the Fixing Web Solenoid (SL9) .....	9- 37
9.5.23 Upper Separation Claw .....	9- 37
9.5.23.1 Removing the Upper Separation Claw .....	9- 37
9.5.23.2 Points to Note When Mounting the Upper Separation Claw .....	9- 38
9.5.24 Lower Separation Claw .....	9- 38
9.5.24.1 Before Removing the Lower Separation Claw (Unit) .....	9- 38
9.5.24.2 Removing the Lower Separation Claw (Unit) .....	9- 39

## Chapter 10 External and Controls

10.1 Control Panel .....	10- 1
10.1.1 Overview .....	10- 1
10.1.2 LCD Indication Processing .....	10- 1
10.1.3 Adjusting the LCD Contrast .....	10- 1
10.1.4 Functions of the Control Panel CPU .....	10- 1
10.2 Counters .....	10- 1
10.2.1 Soft Counters .....	10- 1
10.3 Fans .....	10- 3
10.3.1 Arrangement, Functions, and Error Codes .....	10- 3
10.3.2 Controlling the Speed of the Fans .....	10- 4
10.3.3 Sequence of Operation .....	10- 4
10.4 Power Supply System .....	10- 5
10.4.1 Power Supply .....	10- 5
10.4.1.1 Overview .....	10- 5
10.4.1.2 Distribution of Power and the Switches .....	10- 5
10.4.2 Rated Output of the DC Power Supply PCB .....	10- 7
10.4.2.1 Rated Output of the DC Power Supply PCB .....	10- 7
10.4.2.2 Rated Output of the Accessories Power Supply PCB .....	10- 7
10.4.3 Protection Function .....	10- 8
10.4.3.1 Protective Functions .....	10- 8
10.4.4 Backup Battery .....	10- 8
10.4.4.1 Backup Battery .....	10- 8
10.4.5 Energy-Saving Function .....	10- 8

10.4.5.1 Overview .....	10- 8
10.4.5.2 SNMP setup .....	10- 9
<b>10.5 Parts Replacement Procedure .....</b>	<b>10- 12</b>
10.5.1 External Covers.....	10- 12
10.5.1.1 Right Cover (Lower Rear) .....	10- 12
10.5.1.2 Right Cover (Upper Rear) .....	10- 12
10.5.1.3 Right Cover (Upper) .....	10- 12
10.5.1.4 Left Cover (Upper) .....	10- 12
10.5.1.5 Front Cover .....	10- 13
10.5.1.6 Rear Cover (Upper).....	10- 13
10.5.1.7 Rear Cover (Lower).....	10- 13
10.5.1.8 Left Cover (Lower) .....	10- 13
10.5.1.9 Left Cover (Middle).....	10- 14
10.5.1.10 Toner Supply Cover .....	10- 14
10.5.1.11 Fixing/Feeding Unit Cover .....	10- 14
10.5.1.12 Fixing Cover (Upper) .....	10- 15
10.5.1.13 Fixing Cover (Lower) .....	10- 16
10.5.1.14 Main Controller Box Cover .....	10- 17
10.5.1.15 Reader Left Cover .....	10- 17
10.5.1.16 Reader Right Cover.....	10- 17
10.5.1.17 Reader Front Cover.....	10- 17
10.5.1.18 Reader Rear Cover .....	10- 18
10.5.2 Left Deck Drive Assembly .....	10- 19
10.5.2.1 Before Removing the Left Deck Drive Assembly .....	10- 19
10.5.2.2 Removing the Left Deck Drive Assembly .....	10- 19
10.5.3 Manual Feed Pickup Drive Assembly .....	10- 19
10.5.3.1 Before Removing the Manual Pickup Drive Assembly .....	10- 19
10.5.3.2 Removing the Manual Pickup Drive Assembly .....	10- 19
10.5.4 Vertical Path Drive Assembly .....	10- 19
10.5.4.1 Before Removing the Vertical Path Drive Assembly .....	10- 19
10.5.4.2 Removing the Vertical Path Drive Assembly.....	10- 19
10.5.5 Waste Toner Drive Assembly.....	10- 20
10.5.5.1 Before Removing the Collecting Toner Drive Assembly .....	10- 20
10.5.5.2 Removing the Collecting Toner Drive Assembly .....	10- 20
10.5.6 Main Drive Assembly .....	10- 21
10.5.6.1 Fitting the Drive Belt.....	10- 21
10.5.7 Cassette Pickup Drive Assembly .....	10- 21
10.5.7.1 Before Removing the Cassette Pickup Drive Assembly .....	10- 21
10.5.7.2 Removing the Cassette Pickup Drive Assembly .....	10- 21
10.5.8 Fixing Drive Assembly.....	10- 22
10.5.8.1 Before Removing the Fixing Drive Assembly .....	10- 22
10.5.8.2 Removing the Fixing Drive Assembly .....	10- 22
10.5.9 Power Supply Unit.....	10- 22
10.5.9.1 Removing the Charger unit .....	10- 22
10.5.9.2 Points to Note At Occurrence of Charger unit Malfunction .....	10- 22
10.5.10 Duplex Unit PCB .....	10- 23
10.5.10.1 Before Removing the Duplex unit PCB .....	10- 23
10.5.10.2 Removing the Duplex Unit PCB .....	10- 23
10.5.11 Control Panel.....	10- 23
10.5.11.1 Before Removing Control Panel .....	10- 23
10.5.11.2 Removing Control Panel .....	10- 23
10.5.12 DC Controller PCB .....	10- 24
10.5.12.1 Before Removing DC Controller PCB .....	10- 24
10.5.12.2 Removing DC Controller PCB .....	10- 24
10.5.12.3 When Replacing DC Controller PCB .....	10- 24
10.5.13 Printer Power Supply PCB .....	10- 24
10.5.13.1 Before Removing Printer Power Supply PCB .....	10- 24
10.5.13.2 Removing Printer Power Supply PCB .....	10- 24
10.5.14 Option Power Supply PCB .....	10- 25
10.5.14.1 Before Removing Accessories Power Supply PCB .....	10- 25

---

10.5.14.2 Removing Accessories Power Supply PCB .....	10- 25
10.5.15 Fixing Heater Power Supply PCB .....	10- 25
10.5.15.1 Before Removing Fixing Heater Power Supply PCB .....	10- 25
10.5.15.2 Removing Fixing Heater Power Supply PCB .....	10- 25
10.5.16 Anti-Rush Current PCB .....	10- 26
10.5.16.1 Before Removing Anti-Rush Current PCB .....	10- 26
10.5.16.2 Removing Anti-Rush Current PCB .....	10- 26
10.5.17 High-Voltage Transformer (AC) .....	10- 27
10.5.17.1 Before Removing High Voltage Transformer .....	10- 27
10.5.17.2 Removing High Voltage Transformer .....	10- 27
10.5.17.3 Removing High Voltage Transformer .....	10- 27
10.5.18 HVT PCB .....	10- 28
10.5.18.1 Before Removing HVT PCB .....	10- 28
10.5.18.2 Removing HVT PCB .....	10- 28
10.5.18.3 When Replacing HVT PCB .....	10- 28
10.5.19 Separation Clew AC bias PCB.....	10- 28
10.5.19.1 Before Removing Separation Claw AC PCB .....	10- 28
10.5.19.2 Removing Separation Claw AC PCB .....	10- 28
10.5.20 Motor Driver PCB.....	10- 28
10.5.20.1 Before Removing Motor Driver PCB .....	10- 28
10.5.20.2 Removing Motor Driver PCB .....	10- 28
10.5.21 Primary Fan Duct.....	10- 28
10.5.21.1 Before Removing Primary fan Duct .....	10- 28
10.5.21.2 Removing Primary fan Duct .....	10- 29
10.5.22 Primary Charging Assembly Fan .....	10- 29
10.5.22.1 Before Removing Primary Charging Fan .....	10- 29
10.5.22.2 Removing the Primary Charging Cooling Fan.....	10- 29
10.5.23 De-Curling Fan.....	10- 29
10.5.23.1 Before Removing the Curl-Removing Fan .....	10- 29
10.5.23.2 Removing the Curl-Removing Fan .....	10- 29
10.5.24 Feeding Fan .....	10- 29
10.5.24.1 Before Removing the Feeding Fan .....	10- 29
10.5.24.2 Removing the Feeding Fan .....	10- 30
10.5.25 HVT Fan.....	10- 30
10.5.25.1 Before Removing the HVT Fan .....	10- 30
10.5.25.2 Removing the HVT Fan.....	10- 30
10.5.26 Duplex Feed Fan .....	10- 30
10.5.26.1 Before Removing the Duplex Feeding Fan .....	10- 30
10.5.26.2 Removing the Duplex Feeding Fan.....	10- 30
10.5.27 Exhaust Fan.....	10- 31
10.5.27.1 Before Removing the Exhaust Fan .....	10- 31
10.5.27.2 Removing the Exhaust Fan .....	10- 31
10.5.28 DC Power Supply Fan .....	10- 31
10.5.28.1 Before Removing the DC Power Supply Fan.....	10- 31
10.5.28.2 Removing the DC Power Supply Fan.....	10- 31
10.5.29 Fixing Heater Power Supply Cooling Fan .....	10- 32
10.5.29.1 Before Removing the Fixing Heater Power Supply Cooling Fan.....	10- 32
10.5.29.2 Removing the Fixing Heater Power Supply Cooling Fan .....	10- 32
10.5.30 Circulation Duct Fan .....	10- 32
10.5.30.1 Before Removing the Circulation Duct Fan.....	10- 32
10.5.30.2 Removing the Circulation Duct Fan.....	10- 32
10.5.31 Motor of Main Drive Assembly .....	10- 33
10.5.31.1 Before Removing the Main Motor.....	10- 33
10.5.31.2 Removing the Main Motor .....	10- 33
10.5.32 Fixing Driver Motor.....	10- 33
10.5.32.1 Before Removing the Fixing Motor.....	10- 33
10.5.32.2 Removing the Fixing Motor .....	10- 33
10.5.33 Right Door .....	10- 34
10.5.33.1 Before Removing the Right Door Unit (Upper).....	10- 34
10.5.33.2 Removing the Right Door Unit (Upper) .....	10- 34

Chapter 11 MEAP

11.1 MEAP .....	11- 1
11.1.1 Checking the Operating Environment .....	11- 1
11.1.2 Setting Up the Network .....	11- 4
11.1.3 Setting the method to login to SMS.....	11- 5
11.1.4 Login to SMS.....	11- 9
11.1.5 Checking Application List.....	11- 11
11.1.6 Starting and Stopping a MEAP Application.....	11- 12
11.1.7 Checking the Platform Information.....	11- 13
11.1.8 MEAP Specifications.....	11- 14
11.1.9 Checking the System Information of a MEAP Application with SMS .....	11- 15
11.1.10 Printing the System Information of a MEAP Application .....	11- 16
11.1.11 Reference (Application System Information).....	11- 17
11.1.12 Installing an Application.....	11- 18
11.1.13 MEAP Enterprise Service Manager.....	11- 20
11.1.14 Adding a License File .....	11- 21
11.1.15 Disabling a License File (suspending a license) .....	11- 23
11.1.16 Downloading/Removing an Invalidated License File.....	11- 25
11.1.17 Reusable license .....	11- 27
11.1.18 License for forwarding .....	11- 27
11.1.19 Uninstalling an Application .....	11- 30
11.1.20 Changing Login Services .....	11- 31
11.1.21 Initializing the Password.....	11- 35
11.1.22 Creating a Backup for MEAP Application Area, Formatting the Hard Disk, Restoring the MEAP Application Area with the Backup, Using the SST (Service Support Tool).....	11- 36
11.1.23 Replacing the Hard Disk Drive .....	11- 38
11.1.24 MEAP Safe Mode.....	11- 38
11.1.25 Setting HTTP port for MEAP application (level 2) .....	11- 39
11.1.26 Reference material .....	11- 42
11.1.27 Option for exclusive individual measure.....	11- 43

Chapter 12 e-maintenance/imageWARE Remote

12.1 e-maintenance/imageWARE Remote.....	12- 1
12.1.1 Application operation mode.....	12- 1
12.1.2 Service Center URL and Port Specification .....	12- 1
12.1.3 Communication test .....	12- 1
12.1.4 Communication log .....	12- 1
12.1.5 Detailed Communication log .....	12- 1
12.1.6 SOAP communication function .....	12- 1
12.1.7 Resend at SOAP transmission error .....	12- 2
12.1.8 e-RDS setting screen.....	12- 2
12.1.9 Sleep operation .....	12- 5
12.1.10 Network Setting (Maintenance) .....	12- 5
12.1.11 e-RDS Setting (Maintenance) .....	12- 5
12.1.12 Trouble shoot .....	12- 6
12.1.13 Error message.....	12- 6

Chapter 13 Maintenance and Inspection

13.1 Periodically Replaced Parts.....	13- 1
13.1.1 Outline.....	13- 1
13.1.2 Reader Unit.....	13- 1
13.1.3 Printer Unit .....	13- 1
13.2 Durables and Consumables .....	13- 1
13.2.1 Outline.....	13- 1

---

13.2.2 Reader unit .....	13- 2
13.2.3 Printer Unit.....	13- 2
<b>13.3 Scheduled Servicing Basic Procedure.....</b>	<b>13- 2</b>
13.3.1 Scheduled Servicing Basic Procedure.....	13- 2
13.3.2 Periodical Servicing Chart Reader Unit .....	13- 3
13.3.3 Periodical Servicing Chart Printer Unit .....	13- 4
13.3.4 Points to Note for Periodical Servicing .....	13- 5
<b>13.4 Cleaning.....</b>	<b>13- 6</b>
13.4.1 Cleaning Primary Toner Blocking Sheet .....	13- 6
13.4.2 Cleaning Developing Toner Blocking Sheet .....	13- 6
13.4.3 Cleaning Cleaner Scraper .....	13- 6
13.4.4 Cleaning Photosensitive Drum .....	13- 7
13.4.5 Cleaning the fixing oil dish and the fixing cleaning belt guide.....	13- 8

## Chapter 14 Standards and Adjustments

<b>14.1 Image Adjustment Basic Procedure.....</b>	<b>14- 1</b>
14.1.1 Making Pre-Checks .....	14- 1
14.1.2 Making Checks on the Printer Unit (1/2).....	14- 1
14.1.3 Making Checks on the Printer Unit (2/2).....	14- 3
14.1.4 Making Checks on the Reader Unit .....	14- 4
14.1.5 Checking the Potential System.....	14- 7
14.1.6 Checking the Surface Potential Control System.....	14- 9
14.1.7 Potential Control System Conversion Table .....	14- 11
14.1.8 Emergency Measures for a Fault in the Potential Sensor .....	14- 16
<b>14.2 Image Adjustments .....</b>	<b>14- 17</b>
14.2.1 Standards of Image Position.....	14- 17
14.2.2 Checking the Image Position .....	14- 17
14.2.3 Adjusting Side Registration.....	14- 17
14.2.4 Adjusting the Image Leading Edge Margin.....	14- 18
14.2.5 Adjusting the Left/Right Non-Image Width.....	14- 18
14.2.6 Adjusting the Leading Edge Non-Image Width.....	14- 18
<b>14.3 Scanning System .....</b>	<b>14- 19</b>
14.3.1 After Replacing the Reader Controller PCB .....	14- 19
14.3.2 When Replacing the CCD Unit .....	14- 19
14.3.3 Adjusting the Position of the No. 1/No. 2 Mirror Base .....	14- 19
14.3.4 When Replacing the Copyboard Glass.....	14- 20
14.3.5 When Replacing the Reading Glass.....	14- 20
14.3.6 When Replacing the Scanning Lamp .....	14- 20
14.3.7 After Replacing the Inverter PCB.....	14- 20
<b>14.4 Laser Exposure System.....</b>	<b>14- 20</b>
14.4.1 When Replacing the Scanner Unit.....	14- 20
<b>14.5 Image Formation System.....</b>	<b>14- 20</b>
14.5.1 Outline .....	14- 20
14.5.2 Routing Charging Wire .....	14- 20
14.5.3 Routing Grid for Primary Charging Assembly .....	14- 21
14.5.4 Adjusting Height of Charging Wire .....	14- 21
14.5.5 Mounting Cleaning Blade .....	14- 22
14.5.6 Removing Side Seal .....	14- 22
<b>14.6 Fixing System .....</b>	<b>14- 22</b>
14.6.1 Applying Grease After Replacing the Fixing Roller.....	14- 22
14.6.2 Adjusting the Nip Width .....	14- 23
14.6.3 Adjusting the Fixing Web Solenoid (SL9) .....	14- 23
14.6.4 After Replacing the Fixing Web .....	14- 23
14.6.5 Adjusting the Fixing Inlet Guide Solenoid (SL1) .....	14- 23

14.6.6 Adjusting the Position of the Fixing Inlet Guide.....	14- 23
14.7 Electrical Components.....	14- 23
14.7.1 When Replacing DC Controller PCB .....	14- 23
14.7.2 When Replacing HVT PCB .....	14- 24
14.7.3 After Replacing the HDD.....	14- 24
14.7.4 When Replacing the Main Controller PCB.....	14- 24
14.8 Pickup/Feeding System.....	14- 24
14.8.1 Points to Note When Mounting the Pickup Roller.....	14- 24
14.8.2 Points to Note When Mounting the Separation Roller.....	14- 24
14.8.3 The Points to Mount the Feeding Roller.....	14- 24
14.8.4 Adjusting the Pressure of the Deck/Cassette Separation Roller.....	14- 25
14.8.5 Adjusting the Pressure of the Manual Separation Roller .....	14- 25
14.8.6 Adjusting the Position of the Pickup Solenoid (SL3, SL4) of the Cassette 3/4 .....	14- 25
14.8.7 Adjusting the Position of the Delivery Flapper Solenoid (SL5).....	14- 25
14.8.8 Adjusting the Position of the Right Deck Pickup Solenoid (SL6) .....	14- 25
14.8.9 Adjusting the Position of the Left Deck Pickup Solenoid.....	14- 26
14.8.10 Mounting the Reversing Flapper Solenoid .....	14- 26
14.8.11 Attaching the Side Guide Timing Belt in the Manual Feed Tray Assembly.....	14- 26
14.8.12 Adjusting the Position of the Lifter Motor M20/M21 of the Cassette 3/4 .....	14- 26

## Chapter 15 Correcting Faulty Images

15.1 Making Initial Checks.....	15- 1
15.1.1 Site Environment.....	15- 1
15.1.2 Checking the Originals for Symptoms.....	15- 1
15.1.3 Copyboard Cover, Copyboard Glass, and Standard White Plate .....	15- 1
15.1.4 Checking the Charging Assemblies .....	15- 1
15.1.5 Checking the Developing Assembly.....	15- 1
15.1.6 Checking the Paper.....	15- 1
15.1.7 Checking the Periodically Replaced Parts .....	15- 1
15.1.8 Image Adjustment Basic Procedure.....	15- 1
15.1.9 Others .....	15- 1
15.2 Outline of Electrical Components .....	15- 2
15.2.1 Clutch/Solenoid.....	15- 2
15.2.1.1 Clutches and Solenoids .....	15- 2
15.2.2 Motor.....	15- 3
15.2.2.1 Motors .....	15- 3
15.2.3 Fan.....	15- 6
15.2.3.1 Fans .....	15- 6
15.2.4 Sensor.....	15- 8
15.2.4.1 Sensors .....	15- 8
15.2.5 Switch.....	15- 13
15.2.5.1 Switches.....	15- 13
15.2.6 Lamps, Heaters, and Others.....	15- 14
15.2.6.1 Lamps, Heaters, and Others .....	15- 14
15.2.7 PCBs.....	15- 16
15.2.7.1 PCBs .....	15- 16
15.2.8 Connectors.....	15- 18
15.2.8.1 Connectors.....	15- 18
15.2.9 Variable Resistors (VR), Light-Emitting Diodes (LED), and Check Pins by PCB.....	15- 25
15.2.9.1 Variable Resistors (VR), Light-Emitting Diodes, and Check Pins by PCB.....	15- 25
15.2.9.2 DC Controller PCB.....	15- 25
15.2.9.3 DC Power Supply PCB .....	15- 26
15.2.9.4 HVT PCB.....	15- 26

## Chapter 16 Self Diagnosis



---

16.1 Error Code Table .....	16- 1
16.1.1 Error Code .....	16- 1
16.2 Error Code Details .....	16- 2
16.2.1 Detail Error Code .....	16- 2
16.2.2 E602 in Detail .....	16- 16
16.3 Error Code (SEND) .....	16- 18
16.3.1 Results of Self-Diagnosis .....	16- 18
16.3.2 Error Codes .....	16- 19
16.4 Jam Code .....	16- 24
16.4.1 Jam Code (machine proper) .....	16- 24
16.4.2 Jam Code (finisher-related) .....	16- 25
16.4.3 Jam Code (ADF-related) .....	16- 26
16.5 Alarm Code .....	16- 27
16.5.1 Alarm Code .....	16- 27

## Chapter 17 Service Mode

17.1 Outline .....	17- 1
17.1.1 Service mode screen configuration .....	17- 1
17.1.2 Entering or selecting service modes .....	17- 1
17.1.3 Exiting service modes .....	17- 2
17.1.4 Backing Up Service Mode .....	17- 2
17.1.5 Initial screen .....	17- 2
17.1.6 Main/intermediate item screen .....	17- 3
17.1.7 Sub-item screen .....	17- 3
17.2 DISPLAY (Status Display Mode) .....	17- 4
17.2.1 COPIER .....	17- 4
17.2.1.1 COPIER List .....	17- 4
17.2.2 FEEDER .....	17- 11
17.2.2.1 FEEDER List .....	17- 11
17.3 I/O (I/O Display Mode) .....	17- 12
17.3.1 Outline .....	17- 12
17.3.2 R-CON .....	17- 12
17.3.3 FEEDER .....	17- 13
17.3.4 SORTER .....	17- 14
17.3.5 MN-CON .....	17- 19
17.3.6 P-CON .....	17- 19
17.4 ADJUST (Adjustment Mode) .....	17- 23
17.4.1 COPIER .....	17- 23
17.4.1.1 COPIER List .....	17- 23
17.4.2 FEEDER .....	17- 27
17.4.2.1 FEEDER List .....	17- 27
17.4.3 SORTER .....	17- 27
17.4.3.1 SORTER List .....	17- 27
17.5 FUNCTION (Operation/Inspection Mode) .....	17- 27
17.5.1 COPIER .....	17- 27
17.5.1.1 COPIER List .....	17- 27
17.5.2 FEEDER .....	17- 36
17.5.2.1 FEEDER List .....	17- 36
17.6 OPTION (Machine Settings Mode) .....	17- 37
17.6.1 COPIER .....	17- 37
17.6.1.1 COPIER List .....	17- 37
17.6.2 FEEDER .....	17- 62
17.6.2.1 FEEDER List .....	17- 62
17.6.3 SORTER .....	17- 62
17.6.3.1 SORTER List .....	17- 62

17.6.4 BOARD .....	17- 62
17.6.4.1 BOARD List.....	17- 62
17.7 TEST (Test Print Mode).....	17- 63
17.7.1 COPIER .....	17- 63
17.7.1.1 COPIER List.....	17- 63
17.8 COUNTER (Counter Mode).....	17- 64
17.8.1 COPIER .....	17- 64
17.8.1.1 COPIER List.....	17- 64

## Chapter 18 Upgrading

18.1 Outline .....	18- 1
18.1.1 Outline of Upgrading the Machine.....	18- 1
18.1.2 Outline of the Service Support Tool .....	18- 1
18.2 Making Preparations.....	18- 4
18.2.1 Registering the System Software.....	18- 4
18.2.2 Making Connections.....	18- 6
18.3 Formatting the HDD.....	18- 8
18.3.1 Formatting All Partitions .....	18- 8
18.3.2 Formatting Selected Partitions .....	18- 9
18.3.3 Formatting the Partitions .....	18- 9
18.4 Downloading System Software.....	18- 11
18.4.1 Downloading System .....	18- 11
18.4.1.1 Outline.....	18- 11
18.4.1.2 Downloading Procedure.....	18- 11
18.4.2 Downloading RUI, and Language .....	18- 13
18.4.2.1 Outline.....	18- 13
18.4.2.2 Downloading Procedure.....	18- 15
18.4.3 Downloading SDICT.....	18- 16
18.4.3.1 Outline.....	18- 16
18.4.3.2 Downloading Procedure.....	18- 16
18.4.4 Downloading MEAPCONT .....	18- 18
18.4.4.1 Outline.....	18- 18
18.4.4.2 Downloading Procedure.....	18- 18
18.4.5 Downloading KEY .....	18- 19
18.4.5.1 Outline.....	18- 19
18.4.5.2 Downloading Procedure.....	18- 20
18.4.6 Downloading the TTS.....	18- 21
18.4.6.1 Outline.....	18- 21
18.4.6.2 Downloading Procedure.....	18- 21
18.4.7 Downloading BOOT .....	18- 22
18.4.7.1 Outline.....	18- 22
18.4.7.2 Downloading Procedure.....	18- 23
18.4.8 Downloading Dcon and Rcon.....	18- 24
18.4.8.1 Outline.....	18- 24
18.4.8.2 Downloading Procedure.....	18- 25
18.4.9 Downloading G3 FAX.....	18- 26
18.4.9.1 Outline.....	18- 26
18.4.9.2 Downloading Procedure.....	18- 27
18.4.10 Uploading and Downloading Backup Data.....	18- 28
18.4.10.1 Outline.....	18- 28
18.4.10.2 Uploading Procedure.....	18- 29
18.4.10.3 Downloading Procedure.....	18- 31

## Chapter 19 Service Tools

19.1 Service Tools.....	19- 1
19.1.1 List of Special Tools .....	19- 1

19.1.2 List of Solvents/Oils ..... 19- 2



---

## Chapter 1 Introduction

---



---

# Contents

1.1 System Construction .....	1-1
1.1.1 System Configuration with Pickup/Delivery Accessories (230V)EUR .....	1-1
1.1.2 System Configuration with Printing/Transmission Accessories (230V)EUR .....	1-1
1.1.3 Functions and Printing/Transmission Accessories (230V).....	1-2
1.2 Product Specifications.....	1-3
1.2.1 Names of Parts .....	1-3
1.2.1.1 External view .....	1-3
1.2.1.2 Cross-Section .....	1-5
1.2.2 Using the Machine .....	1-7
1.2.2.1 Turning On the Power Switch.....	1-7
1.2.2.2 Turning Off the Power Switch .....	1-7
1.2.2.3 Control Panel.....	1-9
1.2.3 User Mode Items.....	1-9
1.2.3.1 Common Settings.....	1-9
1.2.3.2 Timer Settings .....	1-11
1.2.3.3 Adjustment/Cleaning.....	1-11
1.2.3.4 Report Output.....	1-11
1.2.3.5 System Control Settings.....	1-12
1.2.3.6 Copier Specifications .....	1-14
1.2.3.7 Transmission/Reception Settings.....	1-15
1.2.3.8 Box Settings .....	1-16
1.2.3.9 Printer Settings .....	1-16
1.2.3.10 Address Book Settings .....	1-18
1.2.3.11 Voice Guide Settings.....	1-19
1.2.4 Maintenance by the User .....	1-19
1.2.4.1 Cleaning .....	1-19
1.2.4.2 Checks .....	1-20
1.2.5 Safety .....	1-21
1.2.5.1 Safety of the Machine's Laser Unit.....	1-21
1.2.5.2 CDRH Regulations.....	1-21
1.2.5.3 Handling the Machine's Laser Unit.....	1-22
1.2.5.4 Safety of Toner.....	1-22
1.2.6 Product Specifications .....	1-22
1.2.6.1 Product Specifications.....	1-22
1.2.7 Function List .....	1-24
1.2.7.1 Paper Types.....	1-24
1.2.7.2 Printing Speed .....	1-24
1.2.7.3 Paper Types/Printing Speed (K paper).....	1-25





## 1.1 System Construction

### 1.1.1 System Configuration with Pickup/Delivery Accessories (230V)EUR

iR5065 / iR 5055 / iR5075 / iR5075N / iR5065N / iR5055N

The following shows a typical system configuration:

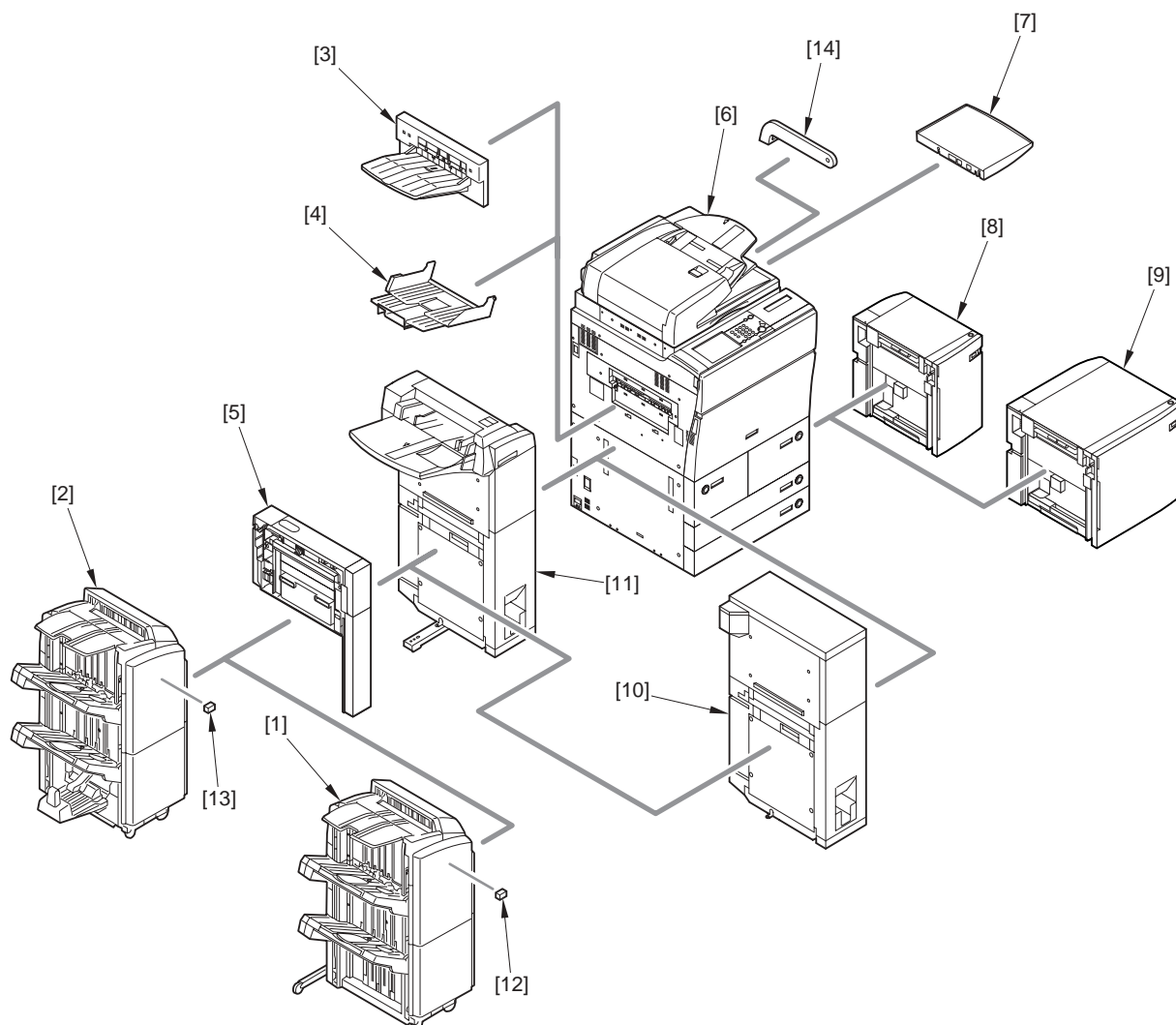

F-1-1  
T-1-1

- [1] Finisher-AD1
- [2] Saddle Finisher-AD2
- [3] Shift Tray-D1
- [4] Copy Tray-L1
- [5] Puncher Unit-AS1/AU1/AV1
- [6] DADF-S1 (standard)
- [7] Document Tray-M1
- [8] Paper Deck-AD1 (A4)
- [9] Paper Deck-AE1 (A3)
- [10] Paper Folding Unit-E1
- [11] Document Insertion/ Folding Unit-F1
- [12] Staple Cartridge-J1
- [13] Staple Cartridge-D2/D3
- [14] ADF Access Handle-A1

### 1.1.2 System Configuration with Printing/Transmission Accessories (230V)EUR

iR5065 / iR 5055 / iR5075 / iR5075N / iR5065N / iR5055N

The following shows a typical system configuration:

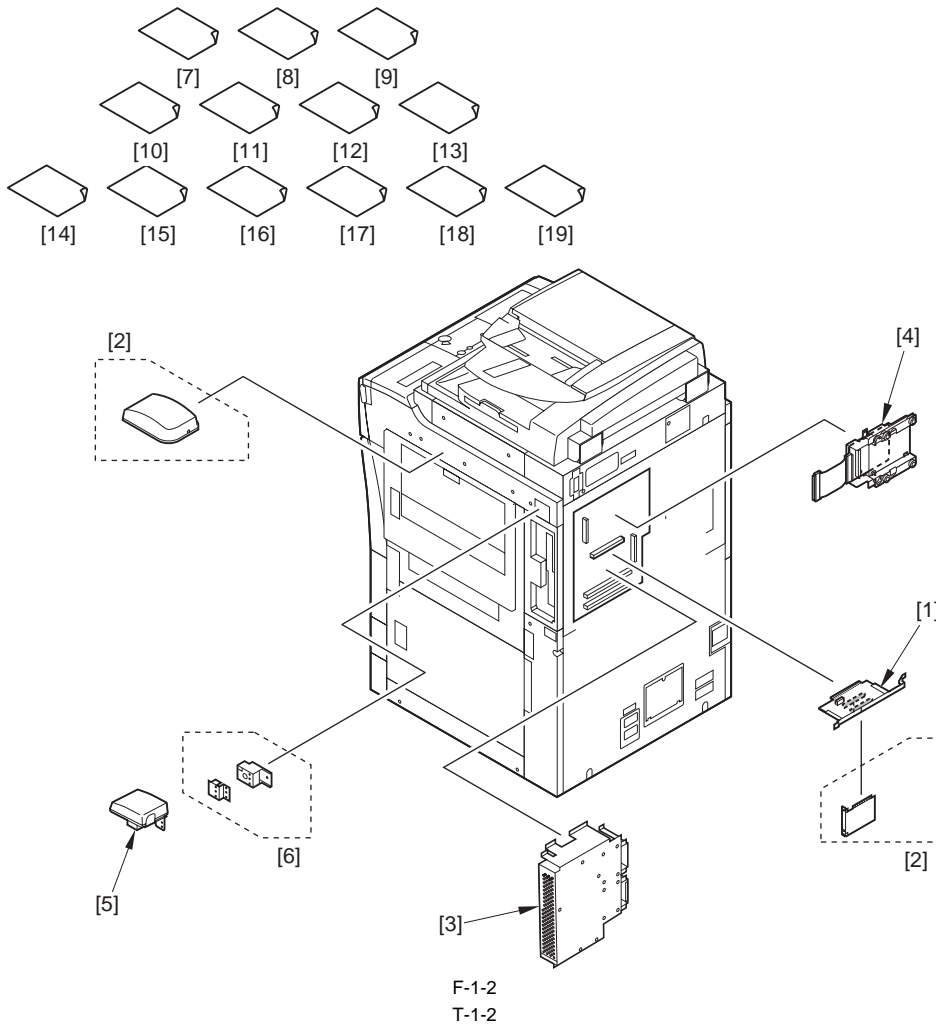

- [1] Expansion Bus-D2
- [2] Voice Guidance Kit-B1
- [3] Super G3 FAX Board-Z1
- [4] HDD Data Encryption Kit-B2
- [5] Card Reader-C1
- [6] Card Reader Attachment-C2
- [7] HDD Data Erase Kit-A1 (license certificate)
- [8] UFR II/PCL Printer Kit-R1 (license certificate)
- [9] PS Printer Kit-R1 (license certificate)
- [10] Barcode Printing Kit-A1 (license certificate)
- [11] Encrypted Printing Software-C1 (license certificate)
- [12] Universal Send Searchable PDF Kit-A1 (license certificate)
- [13] Digital User Signature PDF Kit-A1 (license certificate)
- [14] Web Access Software-F1 (license certificate)
- [15] Remote Operator's Software Kit-A2 (license certificate)
- [16] Secure Watermark-A1 (license certificate)
- [17] AMS KIT (license certificate)
- [18] Universal Send Trial Kit-C1 (license certificate) (standard)
- [19] Canon Universal Send Kit-F1 (license certificate)

### 1.1.3 Functions and Printing/Transmission Accessories (230V)

iR5065 / iR 5055 / iR5075 / iR5075N / iR5065N / iR5055N

The following shows the accessories needed for individual functions:

T-1-3

Function	Accessory needed
LIPS printing	LPS V Expansion Kit-R1
transmission	SEND Expansion Kit-Q1

Function	Accessory needed
faxing	Super G3 Fax Board-Z1
LIPS printing + transmission	LIPS V Expansion Kit-R1 SEND Expansion Kit-Q1
LIPS printing + faxing (1-line)	LIPS V Expansion Kit-R1 Super G3 Fax Board-Z1
MEAP function (w/ copy boot ROM)	- no need for memory expansion both MEAP authentication and MEAP application operation possible
MEAP function (w/ LIPS LX boot ROM)	- if only MEAP authentication is desired no need for memory expansion; if MEAP application is installed, device will not start up (indicating 'E604-0001') - if both MEAP authentication and MEAP application are desired
MEAP application USB connection	HDD Data Encryption Kit-B2 Expansion Bus-D2
security function (HDD formatting + encryption)	HDD Data Encryption Kit-B2 HDD Data Erase Kit-A1 Expansion Bus-D2
PDF/TIFF/JPEG direct printing	LIPS LX Printer & Scanner Unit-R1 LIPS V Expansion Kit-R1 Direct Printing Expansion Kit-F1
searchable PDF function	SEND Expansion Kit-Q1 Universal Send Searchable PDF Kit-A1
Electronic signature PDF function	User Signature PDF-A1
voice guidance	Voice Guidance Kit-B1 Expansion Bus-D2
remote operation	Remote Operation Kit-A1
Web browsing	Web Browser Expansion Kit-C2
Secure print function	Encrypted Printing Software A1

## 1.2 Product Specifications

### 1.2.1 Names of Parts

#### 1.2.1.1 External view

iR5065 / iR 5055 / iR5075 / iR5075N / iR5065N / iR5055N

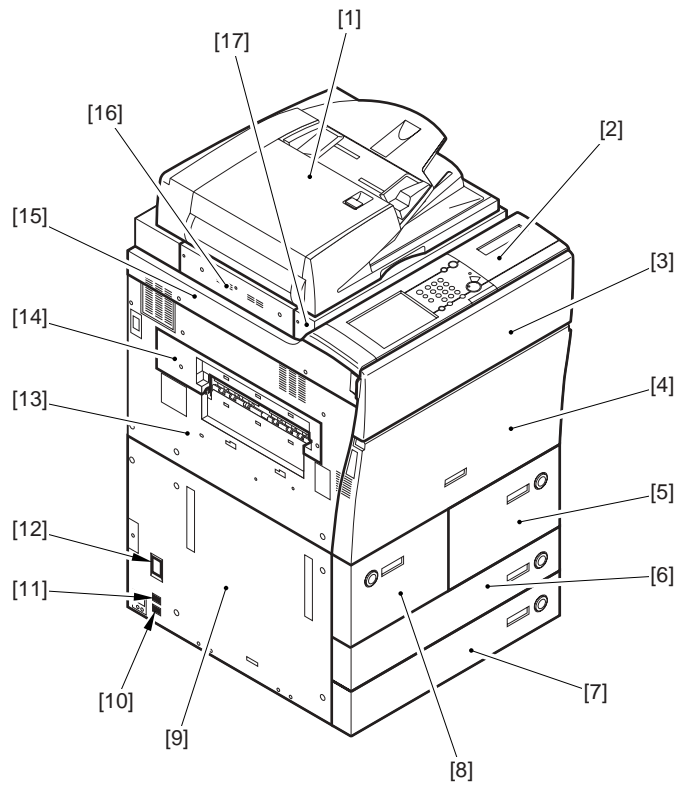

F-1-3

- [1] Feeder
- [2] Control panel
- [3] Toner access cover
- [4] Front cover
- [5] Right front deck
- [6] Cassette 3
- [7] Cassette 4
- [8] Left front deck
- [9] Left cover (paper)
- [10] Environment switch
- [11] Cassette heater switch
- [12] Leakage breaker
- [13] Left cover (middle)
- [14] Delivery cover
- [15] Left cover (upper)
- [16] Reader left cover
- [17] Reader front cover

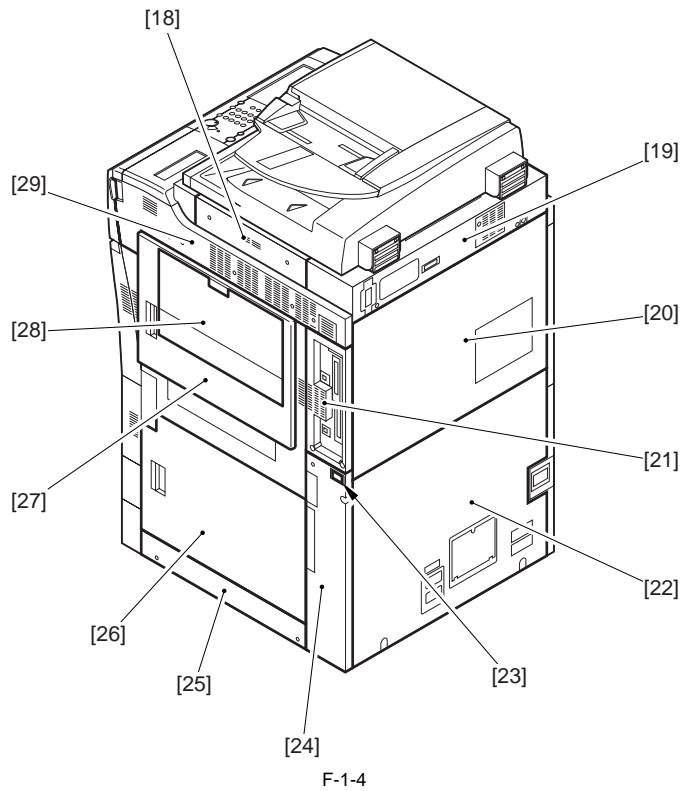

- [18] Reader right cover
- [19] Reader rear cover
- [20] Read cover (upper)
- [21] Right cover (upper rear)
- [22] Rear cover (lower)
- [23] Main power switch
- [24] Right cover (lower rear)
- [25] Right cover (lower)
- [26] Right door unit (lower)
- [27] Right door unit (upper)
- [28] Manual feed pickup tray
- [29] Right cover (upper)
- [30] Çbharger unit (iR5075 Japan model only)

### 1.2.1.2 Cross-Section

iR5065 / iR 5055 / iR5075 / iR5075N / iR5065N / iR5055N

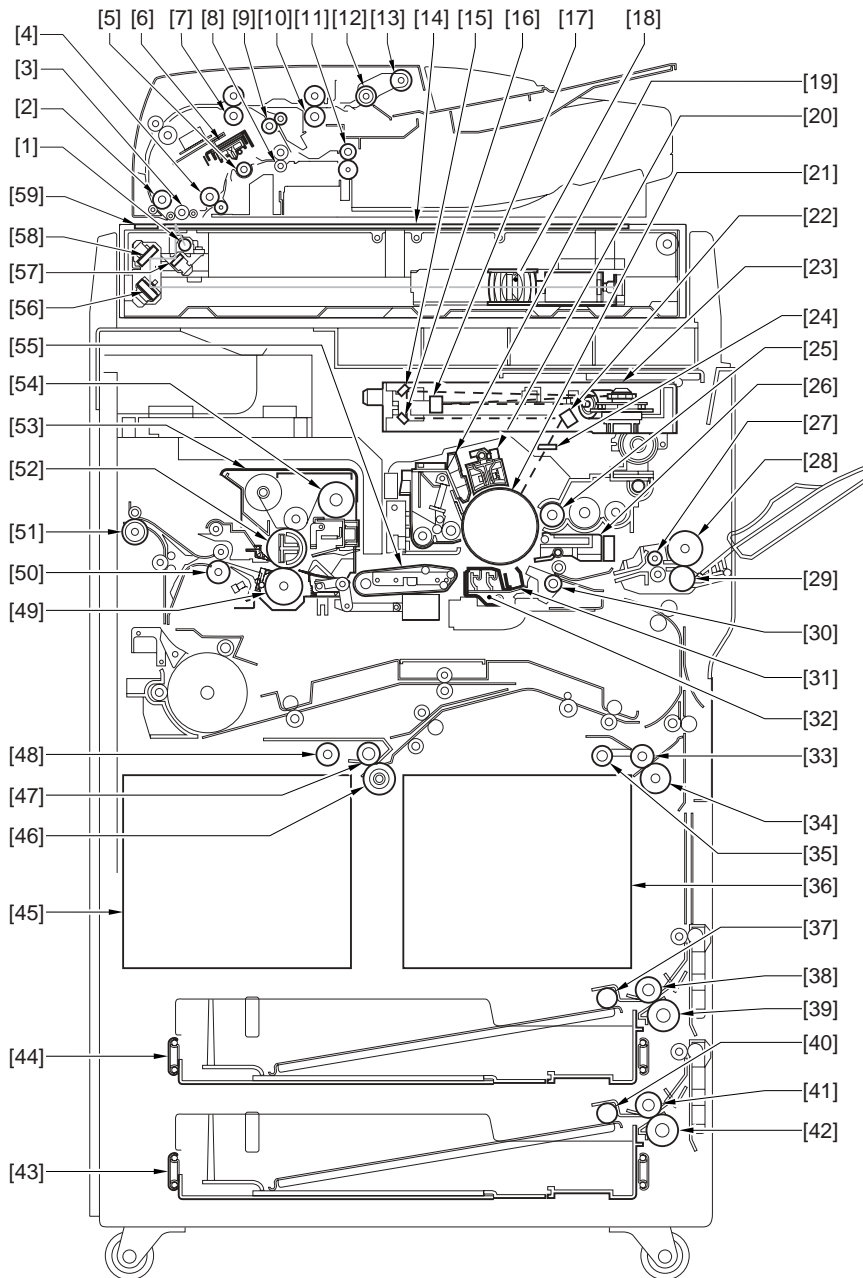

F-1-5  
T-1-4

- |                                    |                                     |
|------------------------------------|-------------------------------------|
| [1] Scanning lamp                  | [2] Read roller 1                   |
| [3] Platen roller 1                | [4] Read roller 2                   |
| [5] Platen roller 2                | [6] CIS unit                        |
| [7] Secondary registration roller  | [8] Read roller 3                   |
| [9] Reversing roller               | [10] Primary registration roller    |
| [11] Delivery roller               | [12] Feeding roller                 |
| [13] Pickup roller                 | [14] Copyboard glass                |
| [15] Laser mirror 2                | [16] Laser mirror 3                 |
| [17] Laser mirror 1                | [18] CCD unit                       |
| [19] Drum cleaner assembly         | [20] Primary charging assembly      |
| [21] Photosensitive drum           | [22] Laser mirror 4                 |
| [23] Laser unit                    | [24] Dust-proofing glass            |
| [25] Developing cylinder           | [26] Pre-transfer charging assembly |
| [27] Manual feed pull-out roller   | [28] Manual feed feed roller        |
| [29] Manual feed separation roller | [30] Registration roller            |
| [31] Transfer charging assembly    | [32] Separation charging assembly   |
| [33] Right deck feed roller        | [34] Right deck separation roller   |
| [35] Right deck pickup roller      | [36] Right deck                     |
| [37] Cassette 3 pickup roller      | [38] Cassette 3 feed roller         |
| [39] Cassette 3 separation roller  | [40] Cassette 4 pickup roller       |

[41] Cassette 4 feed roller	[42] Cassette 4 separation roller
[43] Cassette 4	[44] Cassette 3
[45] Left deck	[46] Left deck separation roller
[47] Left deck feed roller	[48] Left deck pickup roller
[49] Fixing lower roller	[50] Internal delivery roller
[51] External delivery roller	[52] Fixing upper roller
[51] Fixing assembly	[54] Fixing web
[55] Feeding assembly	[56] No.3 mirror
[57] No.1 mirror	[58] No.2 mirror
[59] ADF reading glass	

## 1.2.2 Using the Machine

### 1.2.2.1 Turning On the Power Switch

iR5065 / iR 5055 / iR5075 / iR5075N / iR5065N / iR5055N

The machine is equipped with 2 power switches: main power switch and control panel power switch. Normally, i.e., other than sleep state, the machine starts up when the main power switch is turned on.

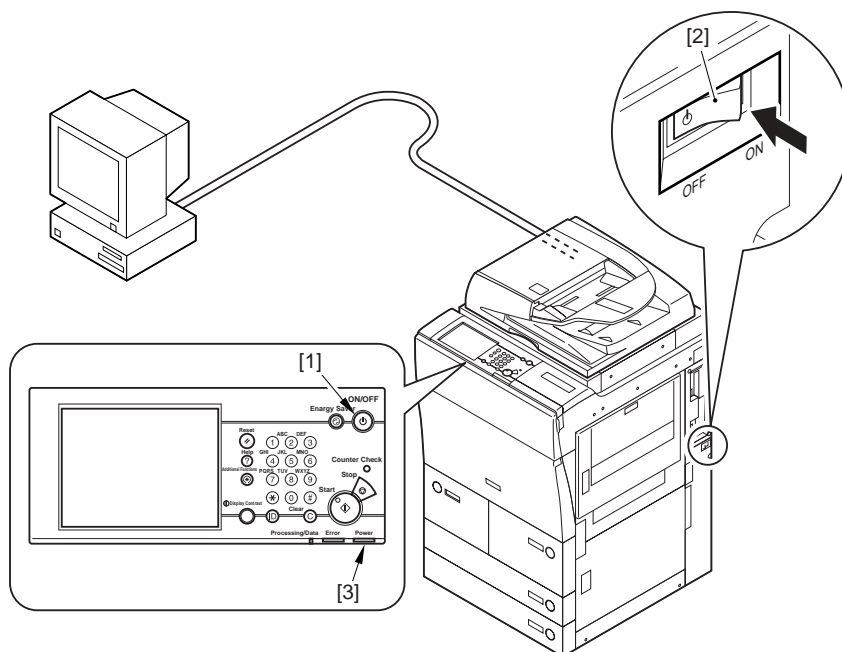

F-1-6

- [1] Control panel power switch
- [2] Main power switch
- [3] Main power lamp



Never turn off the main power switch while the progress bar is shown, indicating that the machine HDD is being accessed. Otherwise, the HDD can develop a fault (E602).

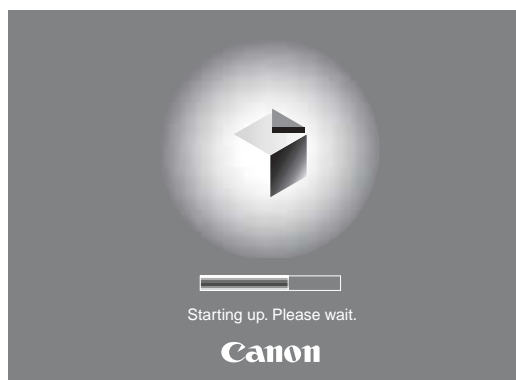

F-1-7

### 1.2.2.2 Turning Off the Power Switch

iR5065 / iR 5055 / iR5075 / iR5075N / iR5065N / iR5055N

---

Be sure to go through the shut-down sequence whenever turning off the main power switch.

---



**How to Turn Off the Main Power Switch**

To turn off the main power switch, be sure to go through the following steps to prevent damage to the machine's hard disk:

- 1) Hold down the control panel power switch for 3 sec or more.
- 2) Go through the down-sequence instructions indicated on the touch panel so that the main power switch may be turned off.
- 3) Turn off the main power switch.

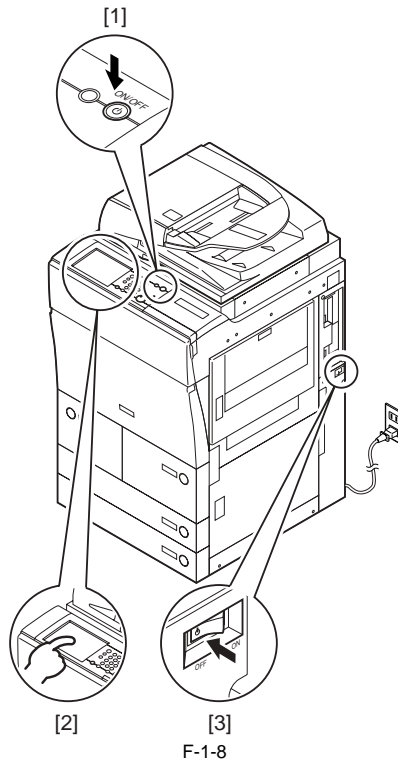

**While Downloading Is Under Way**

Never turn off the main power switch/control panel power switch while downloading is under way. (If the main power switch is turned off while downloading is under way, the machine can fail to operate.)



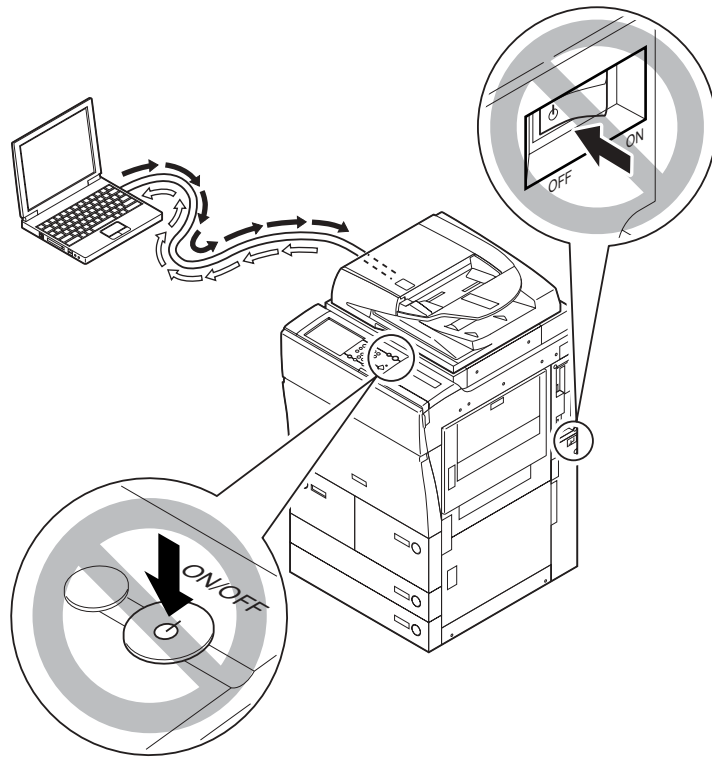

F-1-9

1.2.2.3 Control Panel

iR5065 / iR 5055 / iR5075 / iR5075N / iR5065N / iR5055N

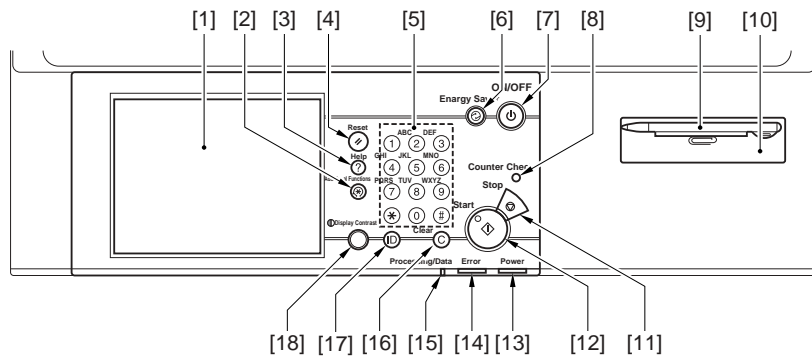

F-1-10

- |                                |                                       |
|--------------------------------|---------------------------------------|
| [1] Touch Panel Display        | [2] Initial Settings/Registration Key |
| [3] Easy NAVI Key              | [4] Release key                       |
| [5] Keypad                     | [6] Power Save key                    |
| [7] Control panel power switch | [8] Counter Check Key                 |
| [9] Touch Pen                  | [10] Clip recess                      |
| [11] Stop key                  | [12] Start key                        |
| [13] Main power lamp           | [14] Error lamp                       |
| [15] Execute/Memory lamp       | [16] Clear key                        |
| [17] ID (Authentication) Key   | [18] Display contrast dial            |

1.2.3 User Mode Items

1.2.3.1 Common Settings

iR5065 / iR 5055 / iR5075 / iR5075N / iR5065N / iR5055N

\*Factory settings.

\*\*Indicated when the appropriate accessory is installed.

T-1-5

Mode	Description
initial function	select initial function: *copier/transmit/fax, print,box/MEAP

Mode	Description
	use 'system status screen' as initial screen: ON/*OFF
	give priority to 'device' of 'system status screen': *ON/OFF
post-auto clear function	*use previous/do not use previous
	function group order setup: group A, MEAP, group B
enable/disable buzzer	input sound: *ON/OFF input invalid sound: ON/*OFF replenish alert sound: ON/*OFF alert sound: *ON/OFF job end sound: *ON/OFF
indicate power level message	*ON/OFF
inch input	ON/*OFF (if US, *ON)
enable/disable cassette auto select	copier/printer/box/other (manual feed: ON/*OFF + individual cassette: *ON/OFF) consider copy/power type: *ON/OFF (toggle)
register paper type	right cassette deck/left cassette deck: plain paper/colored paper/recycled paper/heavy paper/bond paper (outside Japan)/letterhead (plain paper; outside Japan)/letterhead (heavy paper; outside Japan)/punched paper (outside Japan)  cassettes 3/cassette 4: *plain paper/colored paper/recycled paper/bond paper (outside Japan)/letterhead (plain paper; outside Japan)/letterhead (heavy paper; outside Japan)/punched paper (outside Japan)/index sheet  cassette 5 (paper deck): *plain paper/colored paper/recycled paper/heavy paper/bond paper (outside Japan)/letterhead (heavy paper; outside Japan)/punched paper (outside Japan)
change power save mode	*-10%, -25%, -50%, no recovery interval
set power consumption level in sleep state	*low/high
set delivery tray** (w/ finisher)	With Finisher, AD1 / Saddle Finisher, AD2 attached  Tray A: Copy, box, printer, *reception/*fax, *others *Tray B: *Copy, *box, *printer, reception/fax, others Tray C: *Copy, *box, *printer, reception/fax, others  Basic position of the tray: *Tray B / Tray C / Not specified
set printing priority	copier: *1/2/3 printer: 1/*2/3 box: 1/2/*3 reception/fax: 1/2/*3 other: 1/2/*3
register image for image merge	register: original size/full merge, see-through merge (20, *50, 99%) form name (24 characters max.) form read delete  check coy: cassette select, print sort detail info: display detail info, change form name
register character string for print/stamp	register/edit: change character string (16 character max.)  delete
register manual feed paper standard mode	ON (select paper size/select paper type)/*OFF
select standard mode for local print	select paper type: *auto paper select/paper source select number of prints: *1 to 9999 sorter: sort/group/staple sort/*shift sort/shift group/rotation sort/rotation group/punch hole/z-fold/C-fold duplex print: ON (open like book/open like calendar) OFF delete file after printing: merge file:
switch language	ON/*OFF
reverse screen color	ON/*OFF
between-job shift**	*ON/OFF

Mode	Description
between-job interleaf	ON (paper source select) *OFF
between-set interleaf	ON (setting range between *10 and 9999; paper source select) *OFF
right wait time indication	copier/box/other (for each, ON/*OFF)
Registration of the size of the side paper deck**	A3/A4/A4R/B4/B5/11×17/LGL/LTR/LTRR
output tray paper mix**	*ON/OFF
original reading area cleaning prompt	*ON/OFF
function limit mode**	ON/*OFF
shut-down mode	execute key
reset common settings	Do you really want to reset?: yes/no

### 1.2.3.2 Timer Settings

iR5065 / iR 5055 / iR5075 / iR5075N / iR5065N / iR5055N

\*Factory default.

T-1-6

Mode	Description
time fine-adjust	by +/- in 1-min increments
auto sleep time	10 sec; *1, 2, 10, 15, 20, 30, 40, 50 min; 1 hr; 90 min; 2, 3, 4 hr
auto clear time	0=none, 1, ..., *2, ..., 9 min (in 1-min increments)
silent mode shift time	0=none, 1*, ..., 9 min (1-min increments)
set weekly timer	everyday from Sun to Sat (00:00 to 23:59; in 1-min increments)

### 1.2.3.3 Adjustment/Cleaning

iR5065 / iR 5055 / iR5075 / iR5075N / iR5065N / iR5055N

\*Factory default.

\*\*Indicated when the appropriate accessory is installed.

T-1-7

Mode	Description
zoom fine-adjust	XY, independent: -1.0% to +1.0% (in 0.1%-increments), *0%
center bind staple edging**	start key
change middle bind position** (w/ saddle finisher)	size: A3, 11×17/B4/A4R, LTR, LGL position: -2.0 mm to +2.0 mm (in -0.25-mm increments), *0 mm
Adjustment of the creep (displacement) correction volume	Correction volume (For each type of paper): 0.00 to 2.00mm (Interval of 0.05mm) *0.25mm
Adjustment of the folding position**	Adjustment of Z-fold position -2mm to +1.5mm, *0mm (incremented by 0.5mm) Adjustment of C-fold position A: 0.0mm to 6.0mm, *0mm B: 0.0mm to 3.0mm, *0mm (incremented by 0.5mm)
correct density	copier/box, transmit: 9 steps each (at time of shipment, set to '5')
Adjustment of contrast of characters/background	Relative contrast value: -7 to *+7, 0 Print setting for sample printing Setting of the standard value: 0 to 64, *20 Density of a latent image: 0 to 36, *8
Feeder cleaning	Start key
Drum cleaning	Start key
Wire cleaning	Start key

### 1.2.3.4 Report Output

iR5065 / iR 5055 / iR5075 / iR5075N / iR5065N / iR5055N

\*Factory default.

\*\*Indicated when the appropriate accessory is installed.

T-1-8

Mode	Description
transmit (specifications setup)**	transmission result report: *only if error/ON/OFF indicate transmission original: *ON/OFF

Mode	Description
fax (specifications setup)**	transmission control report print every 100 communications: *ON/OFF print at specific time: *ON/OFF time settings: *00:00 to 23:59 separate transmission/reception: (toggle) ON/*OFF fax transmission result report: *only if error/ON/OFF  indicate transmission original: *ON/OFF
print list (transmission)**	fax communications control report print automatically every 40 communications: *ON/OFF print at specific time: ON/*OFF time setting: *00:00 to 23:59 separate transmission/reception: (toggle) ON/*OFF fax reception results report: *only if error/ON/*OFF  fax box reception report: *ON/OFF address book list: print list  user data request: Do you want to print the user data list?: yes/no
print list (fax)**	user data list: Do you want to print the user data list?: yes/no

### 1.2.3.5 System Control Settings

iR5065 / iR 5055 / iR5075 / iR5075N / iR5065N / iR5055N

\*Factory default.

\*\*Indicated when the appropriate accessory is installed.

\*\*\*Indicated when the appropriate accessory is installed. ÅiR5065,iR5055Åj

T-1-9

Mode	Description
set system administrator information	system control group ID: 7 characters max. system control ID: 7 characters max. system administrator name: 32 bytes  mail address: 64 bytes contact: 32 bytes comment: 32 bytes
group ID controller	group ID control: ON/*OFF  ID No. register: register, edit, delete, function control  count control: clear, count print, all clear print job w/ unknown ID: *ON/OFF scan job w/ unknown job: *ON/OFF
communication control setup	e-mail/*i-fax setup  transmission data size upper limit: 0=none, 1 to 99 MB; *3 MB abbreviation: 40 characters or 20 2-byte characters; *attached images transmission time-out in full state: 1 to 99 hr, *24 hr Timeout in divided reception: 1 to 99 hours, *24 hours  print for MDN/DSN reception: ON/*OFF always notify if reception error: *ON/OFF relay through server: ON/*OFF Permit MDN not via server: *ON/OFF  fax setup**  transmission start speed: *33600bps, 14400bps, 9600bps, 7200bps, 4800bps, 2400bps  reception start speed: 33600bps*, 14400bps, 9600bps, 7200bps, 4800bps, 2400bps  reception password: 20 characters max. FIS switch: ON/*OFF  system box setup  system box ID No.**: 7 characters use fax memory reception**: ON/*OFF use i-fax memory reception**: ON/*OFF memory reception start time**: by day, by day of week, *no specification

Mode	Description
	memory reception end time**: by day, by day of week, *no specification
enable/disable remote UI	*ON/OFF use SSL: ON/*OFF
limit target**	address book ID No.: 7 characters max. address book access No. control: ON/*OFF new target limit: ON/*OFF
Permit transmission from the fax driver	*ON/OFF
Entry for confirmation when entering a fax number	ON/*OFF
Restrictions of the domain for transmission of email/IFAX	Restrictions of the domain for transmission: ON/*OFF Permitted domain for transmission: Registration, details/edit, deletion
Permit PDF transmission when using an expired certificate	ON/*OFF
Always attach a device signature when performing PDF transmission	ON/*OFF
device information setup	device name: 32 characters, or 16 2-byte characters installation site: 32 characters, or 16 2-byte characters
transfer setup**	reception method, enable/disable condition, registration, unconditional transfer registration, e-mail priority, detail/edit, delete, list print
delete bulletin	delete
auto on-line/off-line shift***	auto on-line shift: ON/*OFF auto off-line shift: ON/*OFF date/time setup: set (12 numeric characters) time zone: GMT -12:00 to GMT +12:00 (GMT +*9:00) daylight saving time: ON/*OFF
adjust date/time	set (12 characters) time zone: GMT -12:00 to GMT +12:00 (GMT +*9:00) daylight saving time: ON, *OFF
register LDAP server**	register, detail/edit, delete, Registration/edit of LDAP search attributes,list print
register license	24 characters
set print expansion	ON/*OFF group ID: ON/*OFF date: ON/*OFF text: ON/*OFF
Restrictions in the system status screen	Display the job status before authentication: *ON/OFF Permit secure print from the print status: ON/*OFF Display the job history: *ON/OFF Obtain the job history from the management software: Permit / Prohibit
MEAP setup	use HTTP: *ON/OFF use SSL: ON/*OFF print system info: print

Mode	Description
set machine information distribution	<p>- register recipient: auto search/register, register, detail info, delete,list printing</p> <p>- auto distribution: every day, by day of week. *no specification user mode setting: ON/*OFF network setup: include, do not include group ID: ON/*OFF address book: ON/*OFF Setting of the print specifications: ON/*OFF</p> <p>- manual distribution setup: user mode settings: ON/*OFF network setup: include, do not include group ID: ON/*OFF address book: ON/*OFF Setting of the print specifications: ON/*OFF</p> <p>- limit reception according to original ON/*OFF</p> <p>- recover data: user mode settings, group ID, address book,setting of the print specifications</p> <p>- time reception according to machine: user mode settings: *ON/OFF group ID: *ON/OFF address book: *ON/OFF Setting of the print specifications: ON/*OFF Setting of the print specifications: ON/*OFF</p>
Initialization of all data/settings	Initialization
ON/OFF to display ID/user name	*ON/OFF
Setting of the encryption secure print	Reception of the encryption secure print job: ON/*OFF Automatic printing when using an IC card: ON/*OFF
USB setting	Use the USB device: *ON/OFF Use the USB host: *ON/OFF
ON/OFF to display hidden characters when entering secret information	*ON/OFF
Forcible tint block printing mode**	Copy: *Disable / Enable Box: *Disable / Enable Print: *Disable / Enable
Simultaneous setting for user box	Time until the document is automatically deleted: (0, 1, 2, 3, 6, 12) hours, (1, 2, *3, 7, 30) days Print when saving the data from the printer driver: *ON/OFF

### 1.2.3.6 Copier Specifications

iR5065 / iR 5055 / iR5075 / iR5075N / iR5065N / iR5055N

\*Factory default.

\*\*Indicated when the appropriate accessory is installed.

T-1-10

Mode	Description
quick screen paper select key setup	large* (manual feed/manual feed paper change reservation/(paper source) 1*/(paper source) 2*/(paper source) 3*/(paper source) 4*/(paper source) 5/small
single screen preference key 1 setup	*no setting, individual modes
simple scan preference key 2 setup	*no setting, individual modes
quick screen preference key setup	number of preference keys indicated: 5*/10 setup: set location -> set individual keys *no setting, individual modes
auto sort**	*ON/OFF
priority on screen orientation	ON/OFF*
auto vertical/horizontal rotation	*ON/OFF
print photo mode	ON/*OFF
change standard mode	register/reset (factory shipment: 1 set, auto paper select, auto density, auto image quality; printer: local)
register remote copy printer	priority/register (7 units max.)/detail info/delete
remote copy transmission time-out	*30 (5 to 30) sec

Mode	Description
reset copier specifications	Do you want to reset? yes/no (auto sort: ON/face-up delivery: ON/preference key setup: no)

### 1.2.3.7 Transmission/Reception Settings

iR5065 / iR 5055 / iR5075 / iR5075N / iR5065N / iR5055N

\*Factory default.

\*\*Indicated when the appropriate accessory is installed.

T-1-11

Mode	Description
set common transmission settings**	<p>register source name**: 01 to 99; register/edit (24 characters max.); delete</p> <p>register user abbreviation**: 24 characters max.</p> <p>permit use of non-ASCII code for FTP transmission**: (ON/*OFF)</p> <p>error file clear**: (*ON/OFF)</p> <p>error transfer file handling**: always print/save/print/*off</p> <p>print photo mode**: (ON/*OFF)</p> <p>number of retries**: (*3 times; 0 to 5 times)</p> <p>change transmission function standard mode**</p> <p>read mode: black-and-white machine default *black at 200 dpi/black at 300 dpi/black at 600 dpi/black at 400 dpi (Note: if fax only, black at 200x100*/black at 200x200/black at 200x400/black at 400x400)</p> <p>file type: *TIFF/PDF/PDF(OCR)</p> <p>divide by page: (toggle) ON/*OFF</p> <p>register routine task button**: (register/edit, delete; display comment: ON/*OFF)</p> <p>Display a confirmation message when calling the routine task button: *ON/OFF</p> <p>PDF (OCR setup)**</p> <p>original orientation auto detection: (*ON/OFF)</p> <p>limit number of characters in file name (OCR): (1 to *24)</p> <p>Check the certificate of the device signature</p> <p>Detailed information of the certificate: Verification of the certificate</p> <p>Check the certificate of the user signature</p> <p>Detailed information of the certificate: Verification of the certificate</p> <p>Display a confirmation message when sending the IC card signature: *ON/OFF</p> <p>transmission screen initial display**: routine task button/one-touch button/*new address</p> <p>transmission source record**: *keep/do not keep</p> <p>indication location: inside image/*outside image</p> <p>target abbreviation indication: (*ON/OFF)</p> <p>telephone number marking: *FAX/TEL</p> <p>Use the chunk divided transmission function when sending WebDAV: *ON/OFF</p> <p>Display a confirmation message to check the "Completed" stamp for double-sided transmission: *ON/OFF</p> <p>reset transmission settings: Do you want to reset? yes/no</p>
common reception setup**	<p>duplex record (ON/*OFF)</p> <p>cassette select</p> <p>switch A: (*ON/OFF)</p> <p>switch B: (*ON/OFF)</p> <p>switch C: (*ON/OFF)</p> <p>switch D: (*ON/OFF)</p> <p>image reduction</p> <p>image reception: (*ON/OFF)</p> <p>reduction mode: *auto/fixe</p> <p>fixed mode reduction rate: E210 up: 75% to 97% (in 1% increments), *90%</p> <p>reduction direction: vertical/horizontal, *vertical only</p> <p>2-on-1 record (ON/*OFF)</p>

Mode	Description
fax basic registration setup**	reception info record: keep/*do not keep register user telephone number**  telephone number: 20 characters max. select line type**:  100V: *20 pps/10 pps/push  volume adjust  alarm volume: 0 to 8 (84) communication volume: 0 to 8 (*4) off-hook alarm: (*ON/OFF)
fax transmission function setup**	ECM transmission (*ON/OFF)  set pause length: 1 to 15 seconds (*2 seconds)  auto redial: (*ON/OFF)  number of redial sessions: 100V: 1-15(*2) interval of redial session (min): 2 to 99 (*2) redial at transmission error: 1st and error pages/all pages/off
fax reception function setup**	pre-transmission dial tone check: (*ON/OFF) ECM reception: (*ON/OFF)  select reception mode  *Automatic reception / modem dial-in FAX/TEL switch fax/tel switchover: at ring start: 0 to 30 sec (*8), ring length: 15 to 300 sec (*17), post-ring operation: end/*receive, voice answer: ON/*OFF auto reception modem dial-in fax/tel switchover ring sound: ON (number of rings: 0 to n)/*OFF remote reception: ON (remote reception ID: 00 to 99, *25)/*OFF
fax addition line setup**	auto reception switchover: 1 to 99 seconds, *15 seconds)/*OFF register user telephone number: 20 characters max. register user abbreviation: 24 characters max. select type of line: *20 pps/10 pps/push select transmission line: line 1: *priority on transmission/do not permit transmission line 2: priority on transmission/do not permit transmission

### 1.2.3.8 Box Settings

iR5065 / iR 5055 / iR5075 / iR5075N / iR5065N / iR5055N

\*Factory settings.

\*\*Indicated when the appropriate accessory is installed.

T-1-12

Mode	Description
set/register user box	select box: 0-99 register box name: 24 characters max(one-byte characters). ID No.: 0-9999999 file auto delete: 0=none, 1, 2, 3, 6, 12 hr; 1, 2, *3, 7, 30 days URL transmission setup Print when saving data from the print driver: ON/*OFF reset
print photo mode	(ON/*OFF)
read setup standard mode	register/reset
set/register fax box**	select box: 0-49 register box name: 24 characters max(one-byte characters). ID No.: 0-9999999 set URL transmission reset

### 1.2.3.9 Printer Settings

iR5065 / iR 5055 / iR5075 / iR5075N / iR5065N / iR5055N



\*Factory settings.

\*\*Indicated in the presence of a specific accessory.

T-1-13

Mode	Description
settings	<p>number of copies: 1 to 9999 (*1)</p> <p>duplex: duplex/*simplex</p> <p>pickup</p> <p>default paper size: *A4 (additional 10 possible)  default paper type: plain (additional 8 possible)  paper size replacement: replace/*do not replace</p> <p>adjust print</p> <p>**super smooth: *use/do not use  **toner density: 1 to 9 (*5)  toner save: enable/*disable  thin line correction: *enable/Disable  Correction of horizontal lines: *Disable/Level 1/Level 2/Level 3/Level 4  Correction of horizontal lines: *Disable/Level 1/Level 2/Level 3/Level 4  Resolution: Super Fine/*Fine</p> <p>layout</p> <p>bind position: *Staple the long side/Staple the short side  bind margin: -50to+50mm (*0.0)  Distance to move the stapling position in a direction of the short/long side (front/back): -50to+50mm (*0.0)</p> <p>auto error skip**: skip/*do not skip</p> <p>secure print delete time length: *1, 2, 3, 6, 12, 24 hr</p> <p>timeout: 5 to 300 (*15 sec)/disable</p> <p>RIP: yes/*no</p> <p>sorter**: *do not use/sort/rotation sort/rotation group/shift sort/shift group/staple sort/Staple group</p> <p>punch**: *disable/top/bottom/left/right</p> <p>booklet print**: *disable/open to left/open to right</p> <p>middle bind**: enable/*disable</p> <p>**Correction of creep (displacement): *Disable/Automatic/Correction volume (0 to 10mm)</p> <p>**Insert of the front cover: *Disable/Inserter 1/Inserter 2</p> <p>**Fold: *Disable/Z-fold/C-fold</p> <p>**transparency interleaf: *disable/white sheet/printed sheet</p> <p>**print in sets</p> <p>print in sets: enable/*disable  print position: *5 locations/upper left/lower left/upper right/lower right/Whole image  print start character: 1 to 9999 (*1)  print size: small at 12-point/medium at 24-point/*large at 36-point  density: 1 to 5 (*3)  Adjustment of the printing position (vertical/horizontal): -8 to +8mm (*0)</p> <p>Delivery side specification: *facedown/faceup</p> <p>**printer operating mode: *auto (additional 9 settings possible)  **priority emulation (*none/ additional settings possible)  **auto switchover</p>

Mode	Description
	LIPS: *enable/disable N201: *enable/disable ESC-P: *enable/disable 15577: *enable/disable HP-GL: *enable/disable HP-GL/2: *enable/disable Imaging: *enable/disable PDF1.5: *enable/disable  **connection recognition: *enable/disable  printer settings rest: yes/no

### 1.2.3.10 Address Book Settings

iR5065 / iR 5055 / iR5075 / iR5075N / iR5065N / iR5055N

\*Factory default.

T-1-14

Mode	Description
fax (register address)	register name: Japanese (2-byte zone only); 24 characters telephone number: 120 characters max. (+ pause, tone, <, >, back space, space  ISDN sub address, F net, DT, R, PIN, detail setup detail setup F code: 20 characters max. password: 20 characters max. ECM transmission: *ON/OFF transmission speed: 33600bps*/14400bps/9600bps/4800bps line selection: line 1/line 2/*auto select international transmission: domestic*/international 1/international 2/international 3 communication mode: G4, G3*/G3 only
e-mail (register address)	register name: 24 characters, or 12 2-byte characters register name: Japanese (2-byte zone only); 24 characters  e-mail address: 128 characters
i-fax (register address)	register address: 24 characters, or 12 2-byte characters register name: Japanese (2-byte zone only), 24 characters  mode select: *Simple/Full i-fax address: 128 characters relay through server: ON/*OFF fixed sentence 1: 40 characters fixed sentence 2: 16 characters detail setup paper size: A4/LTR+ B4, A3/11x17 compression method: MH+ MR/MMR resolution: 200x100dpi, 200x200dpi+200x400dpi/300x300dpi/400x400dpi/600x600dpi
file (register addresses)	register name: 24 characters, or 12 2-byte characters register name: Japanese (2-byte zone only), 24 characters  protocol: *FTP/Windows (SMB)/Netware (IPX) host name: 128 characters path to folder: 12* characters user name: FTP, NetWare (IPX); 24 characters Windows (SMB); 15 characters  password: FTP, NetWare (IPX); 24 characters Windows (SMB); 14 characters
group (register address)	register name: 24 characters, or 12 2-byte characters register name: Japanese (2-byte zone only), 24 characters  address book: select from following already registered in address book: fax, e-mail, i-fax, remote file system, jet SEND, box, local printer  save in box: select box: 00 to 99 delete

Mode	Description
search for address (server)	simple search  server to search: from pull-down from LDAP server already registered  (search conditions): name: 128 characters, or 64 2-byte characters e-mail: 12* characters fax: 128 characters  detail search server to search: from pull-down from LDAP server already registered  (search conditions): *name/e-mail/fax/group/group unit under following: * includes next/does not include next/is identical to next/is not identical to next/start with next/ends with next name, group, group unit: 128 characters, or 64 2-byte characters e-main, fax: 128 characters  (condition combination): *or/and search result register type: *all e-mail/fax register e-mail for i-fax: ON/*OFF (toggle)
register name of address book	register name: 16 characters
register one-touch button	register/edit address: register/edit, delete one-touch name: 12 characters max.

### 1.2.3.11 Voice Guide Settings

iR5065 / iR 5055 / iR5075 / iR5075N / iR5065N / iR5055N

\*Factory default.

T-1-15

Mode	Description
voice guide reading volume/speed	volume: 1 to 5* to 9 speed: (slow) -5 to 0* to +5 (fast)
voice type	male/female*
speaker/headphone switch	speaker*/headphone
auto clear in voice guide	ON/OFF*
initialize voice guide settings	Is it OK to initialize? yes/no

## 1.2.4 Maintenance by the User

### 1.2.4.1 Cleaning

iR5065 / iR 5055 / iR5075 / iR5075N / iR5065N / iR5055N

The machine requires cleaning by the user from time to time. Advise the user to perform the following work on a periodical basis (e.g., at least once a month):

#### 1. Platen Board

Clean the platen board cover [1] with a cloth moistened with water or solution of mild detergent (well-wrung); then, dry wipe it with a soft, dry cloth.

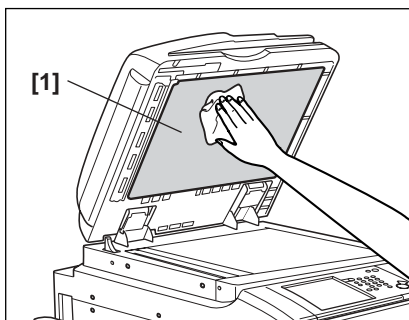

F-1-11

#### 2. Platen Roller

Clean the platen roller [1] with a cloth moistened with water or solution of mild detergent (well-wrung); then, dry wipe it with a dry, soft cloth.

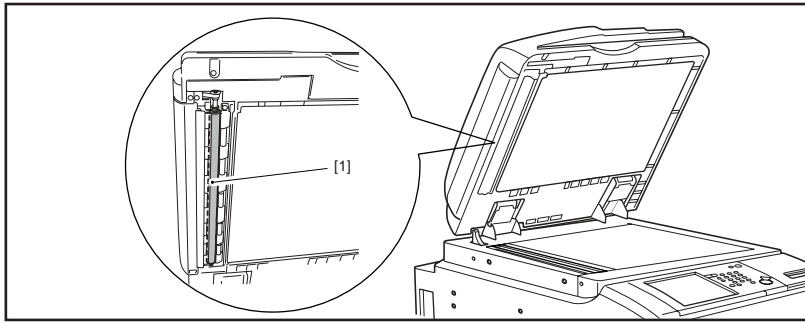

F-1-12

**3. Platen Board Glass/ADF Reading Glass**

Wipe the platen board glass [1] and the ADF reading glass [2] with a cloth moistened with water or solution of mild detergent; then, dry wipe them with a dry, soft cloth.

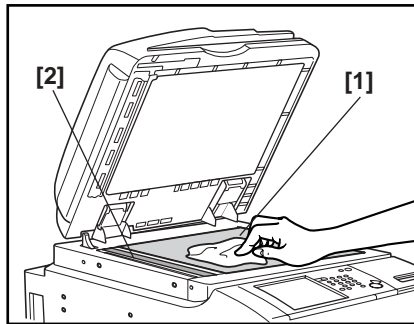

F-1-13

**4. ADF Glass Retainer/Paper Guide Base**

Wipe the ADF glass retainer [1] and the paper guide base [2] with a cloth moistened with water or solution of mild detergent; then, dry wipe them with a dry, soft cloth.

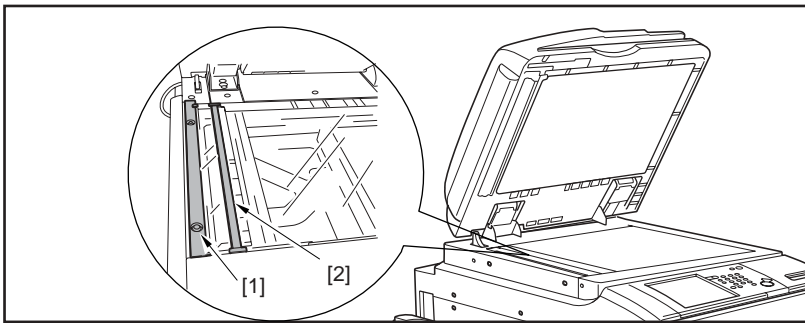

F-1-14

**5. Vertical Size Plate**

Wipe the vertical size plate [1] with a cloth moistened with waste or solution of mild detergent; then, dry wipe them with a dry, soft cloth.

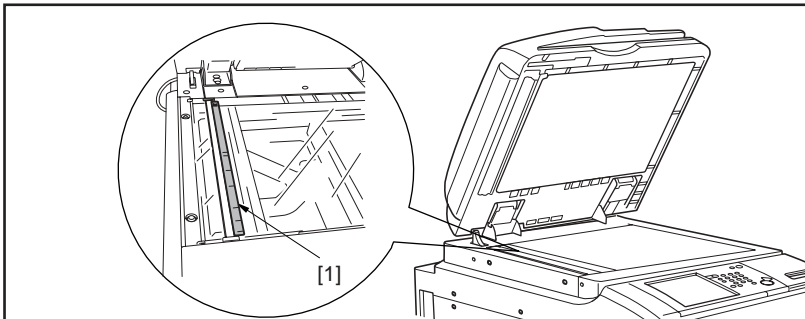

F-1-15

**1.2.4.2 Checks**

iR5065 / iR 5055 / iR5075 / iR5075N / iR5065N / iR5055N

The machine is equipped with a breaker used to check for over-current and leakage current, requiring the user to check the operation of the breaker on a periodical basis (e.g., at least once a month). Also, ask the user to keep a record of checks made.

How to Check the Breaker.

- 1) Turn on the main power switch.
- 2) Press the test button [1] of the breaker using the tip of a ball-point pen or the like.

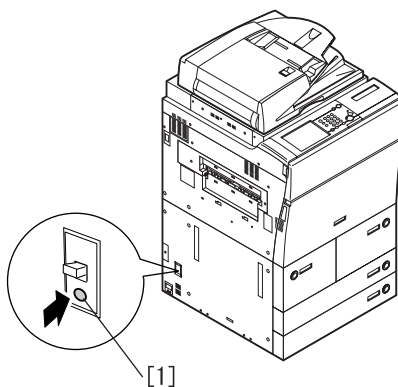

F-1-16

3) Check to see that the breaker switch [1] has shifted to the OFF position, thus cutting off the power.

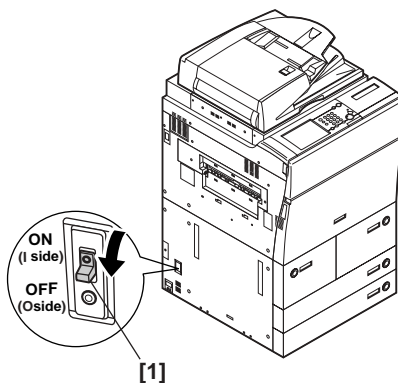

F-1-17

4) Turn off the main power switch.

5) Shift the breaker switch [1] back to the ON position.

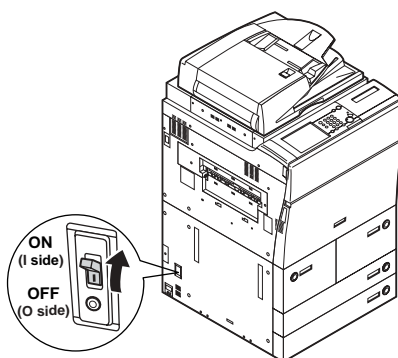

F-1-18



Advise the user that the breaker switch is fully to the ON position. If it is found between ON and OFF positions, it must first be shifted to the OFF position and then to ON.

6) Turn off the main power switch.

## 1.2.5 Safety

### 1.2.5.1 Safety of the Machine's Laser Unit

iR5065 / iR 5055 / iR5075 / iR5075N / iR5065N / iR5055N

Often, laser light can prove to be harmful to the human body. The machine's laser scanner unit is shielded in a protective housing and by external covers so that its light will not escape outside the machine as long as the machine is used in normal operating conditions.

### 1.2.5.2 CDRH Regulations

iR5065 / iR 5055 / iR5075 / iR5075N / iR5065N / iR5055N

The Center for Devices and Radiological Health of the US Food and Drug Administration put into forth regulations intended for laser products. Under the regulations, laser products that are produced on and after August 1, 1976, may not be sold within the US unless they are appropriately certified. The following is a label issued to certify compliance with the regulations and must be found on all laser products sold in the US.

**CANON INC.**  
 30-2, SHIMOMARUKO, 3-CHOME, OHTA-KU, TOKYO,  
 146. JAPAN

**MANUFACTURED :**

THIS PRODUCT CONFORMS WITH DHHS RADIATION  
 PERFORMANCE STANDARD 21CFR CHAPTER 1  
 SUBCHAPTER J.

F-1-19



The text of the label may differ from model to model.

**1.2.5.3 Handling the Machine's Laser Unit**

iR5065 / iR 5055 / iR5075 / iR5075N / iR5065N / iR5055N

Be sure to observe the following whenever you are planning to service the areas around the machine's laser unit:

- Do not put a screwdriver or the like that has a high rate of reflection into the laser path.
- Remove watches and rings before starting the work to avoid reflection of laser light to the eye.

The machine's laser light is red, and its covers that may reflect laser light are identified by a warning label shown below. If you must detach a cover in the field to service the machine, be sure to exercise extra care. (Keep in mind that the machine's laser unit cannot be adjusted in the field.)

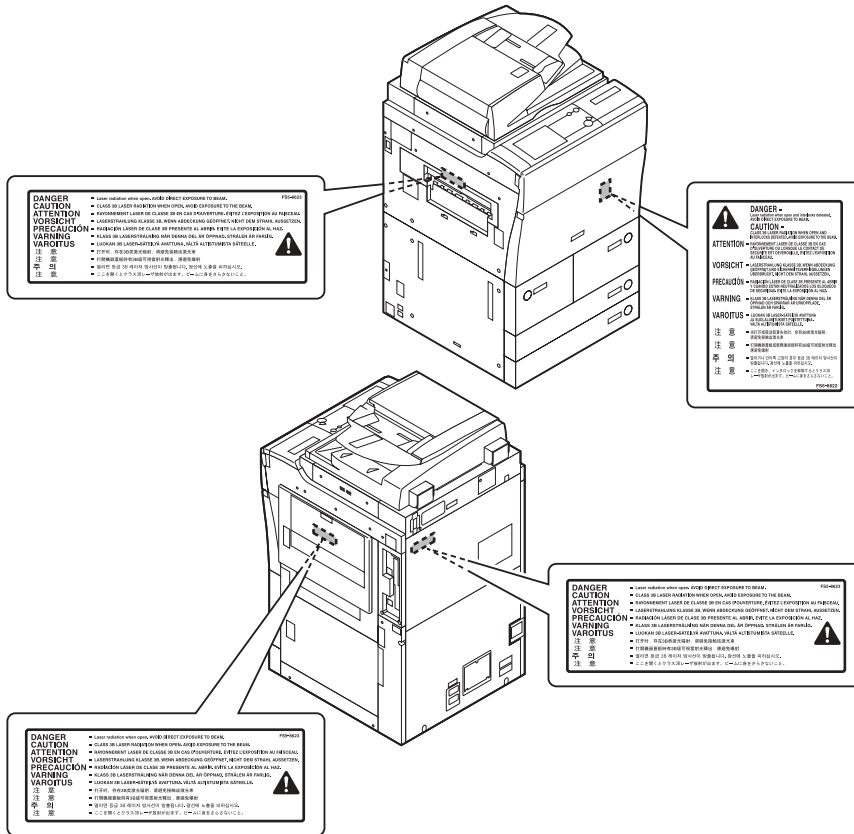

F-1-20

**1.2.5.4 Safety of Toner**

iR5065 / iR 5055 / iR5075 / iR5075N / iR5065N / iR5055N

The machine's toner is a non-toxic material consisting of plastic, iron, and small amounts of colorings.

If your skin or clothes have come into contact with toner, remove as much toner as possible using dry paper tissue, and wash with water. Do not use warm or hot water; otherwise, the toner will jell and fuse permanently with the fibers of the clothes. Also, do not bring toner into contact with vinyl, as it tends to react.



Do not throw toner into fire. An explosion can occur.

**1.2.6 Product Specifications**

**1.2.6.1 Product Specifications**

iR5065 / iR 5055 / iR5075 / iR5075N / iR5065N / iR5055N

<b>Copyboard</b>	stream reading, fixed reading
<b>Body</b>	console
<b>Light source type</b>	xenon lamp (yellow green)
<b>Lens type</b>	fixed focus
<b>Photosensitive medium</b>	A-Si drum (80-mm dia.)
<b>Image reading method</b>	light-receiving element (1 line CCD), CIS
<b>Reproduction method</b>	indirect electrostatic
<b>Exposure method</b>	laser light
<b>Copy density adjustment function</b>	auto or manual
<b>Charging method</b>	corona
<b>Development method</b>	dry, 1-component toner projection
<b>Transfer method</b>	Static transfer
<b>Separation method</b>	static separation
<b>Pickup method</b>	from cassette, manual feeder, paper deck
<b>Cassette pickup method</b>	separation retard
<b>Paper deck pickup method</b>	separation retard
<b>Multifeeder pickup method</b>	separation retard
<b>Drum cleaning method</b>	Cleaning blade
<b>Fixing method</b>	Heat roller fixing (H method)
<b>Delivery method</b>	face-down, face-up
<b>Toner level detection function</b>	yes
<b>Toner type</b>	Magnetic negative toner
<b>Toner supply type</b>	Toner bottle replacement
<b>Original type</b>	sheet, book, 3-D object (2 kg max.)
<b>Maximum original size</b>	304.8mm x 432mm
<b>Original size detection function</b>	main scanning: CCD size detection sub scanning: reflective document sensor
<b>Reproduction ratio</b>	100% (1:1), reduce (1:0.250, 1:0.500, 1:0.611, 1:0.707, 1:0.816, 1:0.865), enlarge (1:1.154, 1:1.224, 1:1.414, 1:2.000, 1:4.000), between (1:0.250 to 4.000) (25% and 400%, in 1%-increments)
<b>Warm-up time</b>	30sec or less
<b>Maximum non-image width (main scanning direction)</b>	2mm or less
<b>Maximum non-image width (sub scanning direction)</b>	2mm or less
<b>Image margin (leading edge)</b>	4.0+1.5/-1.0mm
<b>Image margin (trailing edge)</b>	2.0±1.5mm
<b>Image margin (left/right)</b>	left: 2.5±1.5mm (2nd side: 2.5±2.0mm), right: 0.5mm or more
<b>Non-image width (leading edge)</b>	4.0+1.5/-1.0mm
<b>Non-image width (trailing edge)</b>	2.0±1.5mm
<b>Non-image width (left/right)</b>	2.5±1.5mm
<b>Number of gradations</b>	256 gradations
<b>Reading resolution</b>	600dpi x 600dpi
<b>Copying resolution</b>	600dpi (equivalent) x 600dpi, 1200dpi (equivalent) x 600dpi, 2400dpi (equivalent) x 600dpi
<b>Printing resolution</b>	1200dpi (equivalent) x 1200dpi
<b>First copy time</b>	iR5075N: 3.1sec iR5065 / iR5065N / iR5055 / iR5055N : 3.3sec
<b>Cassette capacity</b>	1200 sheets (64g/m <sup>2</sup> ), 1100 sheets (80g/m <sup>2</sup> )
<b>Multifeeder tray capacity</b>	50 sheets (64, 80g/m <sup>2</sup> )
<b>Paper deck capacity</b>	3400 sheets (64g/m <sup>2</sup> ), 3000 sheets (80g/m <sup>2</sup> )
<b>Duplex method</b>	Through-pass method/Stackless
<b>Delivery tray stack</b>	Copy tray: 250 sheets (80g/m <sup>2</sup> ) Shift tray: 500 sheets (80g/m <sup>2</sup> )
<b>Continuous reproduction</b>	1 - 999
<b>Memory</b>	1GB
<b>Operating environment (temperature range)</b>	15 to 27.5 deg C
<b>Operating environment (humidity range)</b>	25 to 75%
<b>Operating environment (atmospheric pressure)</b>	0.6 to 1.0 atm
<b>Noise</b>	standby: 58 dB or less, printing: 75 dB or less
<b>Hard disk</b>	40GB
<b>Power supply rating</b>	100V 15A/ 120V 20A/ 230V 10A
<b>Sleep mode</b>	yes

<b>Power consumption (maximum)</b>	1500W (100V), 1920W (120V), 2300W (230V)
<b>Power consumption</b>	continuous printing (100V, 50Hz, w / accessories ) : 923 Wh (reference only)
<b>Ozone</b>	Initial: 0.01ppm or less (avr), Later (after 500,000 pages): 0.035 ppm or less (avr)
<b>Dimensions</b>	643mm(W) x 743mm(D) x 1207mm(H)(Including an ADF) * Only for Japan (with a capacitor): 643mm(W) x 839mm(D) x 1207mm(H)(
<b>Weight</b>	220kg ((Including an ADF and toner bottle) * Only for Japan (with a capacitor): 230kg

## 1.2.7 Function List

### 1.2.7.1 Paper Types

iR5065 / iR 5055 / iR5075 / iR5075N / iR5065N / iR5055N

T-1-16

Type	Paper size	Paper feeding position					
		Cassette	Deck (left/right)	Manual feed	3.5 side paper deck	3.5 large paper deck	
Plain paper (60 to 90g/m2) Recycled paper Colored paper Environment paper 3-hole paper 4-hole paper	A4,B5,LTR	yes	yes	yes	yes	yes	
	A3,B4,LDR,LGL	yes	no	yes	no	yes	
	A4R,LTRR	yes	no	yes	no	yes	
	B5R	yes	no	yes	no	no	
	A5R,STMTR	yes	no	yes	no	no	
	A5,STMT	no	no	no	no	no	
Thick paper (91 to 200g/m2) Bond paper	A4,B5,LTR	yes	yes	yes	yes	yes	
	A3,B4,LDR,LGL	yes	no	yes	no	yes	
	A4R,LTRR	yes	no	yes	no	yes	
	B5R	yes	no	yes	no	no	
	EXEC	no	no	yes	no	no	
	A5R,STMTR	yes	no	yes	no	no	
A5,STMT	no	no	no	no	no		
Special paper	OHP film	A4,A4R,LTR,LTRR	no	no	yes	no	no
	Postcard	A4R deformed, Double postal card, Four-face postcard	no	no	yes	no	no
	Label	A4,A4R,B4,LTR,LTRR	no	no	yes	no	no
	Index (tab) paper	A4,LTR	yes	no	no	no	no
	Tracing paper	A3,B4,A4R,A4,B5R,B5	no	no	yes	no	no

### 1.2.7.2 Printing Speed

iR5065 / iR 5055 / iR5075 / iR5075N / iR5065N / iR5055N

T-1-17

Classification	Paper size	E232				E232A				E232B			
		Single-sided		Double-sided		Single-sided		Double-sided		Single-sided		Double-sided	
		Deck cassette feed *1	Multi manual feed	Deck cassette feed *1	Multi manual feed	Deck cassette feed *1	Multi manual feed	Deck cassette feed *1	Multi manual feed	Deck cassette feed *1	Multi manual feed	Deck cassette feed *1	Multi manual feed
Plain paper Colored paper Recycled paper Environment paper 3-hole paper 4-hole paper	A4	75	53	37	26	65	46	32	23	55	46	27	23
	B5	75	53	37	26	65	46	32	23	55	46	27	23
	A5R	35	35	17	17	35	35	17	17	35	35	17	17
	B5R	63	47	31	23	55	41	27	20	46	41	23	20
	A4R	54	44	27	21	47	38	23	19	40	38	20	19
	B4	45	38	22	19	39	33	19	16	39	33	19	16
	A3	37	33	18	16	32	29	16	14	32	29	16	14
	LTR	75	53	37	26	65	46	32	23	55	46	27	23
	STMTR	35	35	17	17	35	35	17	17	35	35	17	17
	LTRR	58	45	28	22	50	39	25	19	43	39	21	19
	LGL	45	38	22	19	39	33	19	16	39	33	19	16
	LDR	37	33	18	16	32	29	16	14	32	29	16	14



Classification	Paper size	E232				E232A				E232B			
		Single-sided		Double-sided		Single-sided		Double-sided		Single-sided		Double-sided	
		Deck cassette feed *1	Multi manual feed	Deck cassette feed *1	Multi manual feed	Deck cassette feed *1	Multi manual feed	Deck cassette feed *1	Multi manual feed	Deck cassette feed *1	Multi manual feed	Deck cassette feed *1	Multi manual feed
Thick paper	A4	63	53	31	26	55	46	27	23	55	46	27	23
	B5	63	53	31	26	55	46	27	23	55	46	27	23
	A5R	28	28	14	14	28	28	14	14	28	28	14	14
	B5R	53	47	26	23	46	41	23	20	46	41	23	20
	A4R	46	44	23	21	40	38	20	19	40	38	20	19
	B4	38	38	19	19	33	33	16	16	33	33	16	16
	A3	31	31	15	15	27	27	13	13	27	27	13	13
	LTR	63	53	31	26	55	46	27	23	55	46	27	23
	STMTR	28	28	14	14	28	28	14	14	28	28	14	14
	LTRR	50	45	24	22	43	39	21	19	43	39	21	19
LGL	38	38	19	19	33	33	16	16	33	33	16	16	
LDR	31	31	15	15	27	27	13	13	27	27	13	13	
Bond paper	LTR	35	35	17	17	30	30	15	15	30	30	15	15
	LTRR	24	24	12	12	21	21	10	10	21	21	10	10
	EXEC	-	35	-	-	-	30	-	-	-	30	-	-
Tracing paper	A4	-	53	-	-	-	46	-	-	-	46	-	-
	B5	-	53	-	-	-	46	-	-	-	46	-	-
	B5R	-	47	-	-	-	41	-	-	-	41	-	-
	A4R	-	44	-	-	-	38	-	-	-	38	-	-
	B4	-	38	-	-	-	33	-	-	-	33	-	-
A3	-	31	-	-	-	27	-	-	-	27	-	-	
OHP	A4	-	53	-	-	-	46	-	-	-	46	-	-
	A4R	-	44	-	-	-	38	-	-	-	38	-	-
	LTR	-	53	-	-	-	46	-	-	-	46	-	-
	LTRR	-	45	-	-	-	39	-	-	-	39	-	-
Postcard	Postcard	-	15	-	-	-	15	-	-	-	15	-	-
	Double postal card	-	28	-	-	-	28	-	-	-	28	-	-
	Four-face postcard	-	53	-	-	-	46	-	-	-	46	-	-
Label	A4	-	53	-	-	-	46	-	-	-	46	-	-
	A4R	-	44	-	-	-	38	-	-	-	38	-	-
	B4	-	38	-	-	-	33	-	-	-	33	-	-
Tab paper	A4	59	-	-	-	51	-	-	-	51	-	-	-
	LTR	59	-	-	-	51	-	-	-	51	-	-	-

\*1: "Deck/cassette feed" includes feeding by the side paper deck.

### 1.2.7.3 Paper Types/Printing Speed (K paper)

iR5065 / iR 5055 / iR5075 / iR5075N / iR5065N / iR5055N

T-1-18

Type	Paper size	Paper feeding position				
		Cassette	Deck (left/right)	Manual feed	3.5 side paper deck	3.5 large paper deck
Plain paper (60 to 90g/m <sup>2</sup> ) Recycled paper Colored paper Environment paper 3-hole paper 4-hole paper	A4,B5,LTR	yes	yes	yes	yes	yes
	A3,B4,LDR,LGL	yes	no	yes	no	yes
	A4R,LTRR	yes	no	yes	no	yes
	B5R	yes	no	yes	no	no
	A5R,STMTR	yes	no	yes	no	no
	A5,STMT	no	no	no	no	no
Thick paper (91 to 200g/m <sup>2</sup> ) Bond paper	A4,B5,LTR	yes	yes	yes	yes	yes
	A3,B4,LDR,LGL	yes	no	yes	no	yes
	A4R,LTRR	yes	no	yes	no	yes
	B5R	yes	no	yes	no	no
	EXEC	no	no	yes	no	no
	A5R,STMTR	yes	no	yes	no	no
A5,STMT	no	no	no	no	no	

Type		Paper size	Paper feeding position				
			Cassette	Deck (left/ right)	Manual feed	3.5 side paper deck	3.5 large paper deck
Special paper	OHP film	A4,A4R,LTR,LTRR	no	no	yes	no	no
	Postcard	A4R deformed, Double postal card, Four- face postcard	no	no	yes	no	no
	Label	A4,A4R,B4,LTR,LTRR	no	no	yes	no	no
	Index (tab) paper	A4,LTR	yes	no	no	no	no
	Tracing paper	A3,B4,A4R,A4,B5R,B5	no	no	yes	no	no

---

## Chapter 2 Installation

---



---

# Contents

2.1 Making Pre-Checks .....	2-1
2.1.1 Selecting the installation space .....	2-1
2.1.2 Combination Table of Accessories .....	2-2
2.1.3 Checking the Contents .....	2-3
2.2 Unpacking and Installation .....	2-5
2.2.1 Unpacking and installation procedure .....	2-5
2.2.2 Unpacking .....	2-5
2.2.3 Installation of Scanner .....	2-7
2.2.4 Installation of Fixing Assembly .....	2-7
2.2.5 Checking of Charging Assembly and Dustproof Glass .....	2-8
2.2.6 Installation of Developing Assembly .....	2-9
2.2.7 Installation of Pickup Assembly .....	2-10
2.2.8 Attaching Deck Pressure Plate .....	2-11
2.2.9 Setting Toner Container .....	2-11
2.2.10 Connecting the Cable .....	2-12
2.2.11 Checking the Environment Switch .....	2-12
2.2.12 Attaching the Label .....	2-13
2.2.13 Connecting the Power Cord .....	2-13
2.2.14 Turning On the Main Power Switch .....	2-14
2.2.15 Toner Stirring .....	2-14
2.2.16 Media Cassette Settings .....	2-14
2.2.17 Index Paper Attachment .....	2-14
2.2.18 Changing the Media Size of the Front Deck (Left/Right) .....	2-15
2.2.19 Image/Operation Check in User Mode .....	2-15
2.2.20 Adjustment of Image Left End Margin .....	2-15
2.2.21 Adjustment of image leading edge margin .....	2-16
2.2.22 Mounting of the Host Machine .....	2-16
2.3 Checking the Connection to the Network .....	2-19
2.3.1 Overview .....	2-19
2.3.2 Checking the Connection to the Network .....	2-19
2.3.3 Using the Ping Command .....	2-19
2.3.4 Making a Check Using the Remote Host Address .....	2-19
2.4 Troubleshooting the Network .....	2-19
2.4.1 Troubleshooting the Network .....	2-19
2.4.2 Checking the Connection of the Network Cable .....	2-19
2.4.3 Making a Check Using a Loopback Address .....	2-19
2.4.4 Making a Check Using a Local Host Address .....	2-19
2.5 Relocating the Machine .....	2-20
2.5.1 Operation for Moving the Machine .....	2-20
2.6 Installing the Copy Tray .....	2-20
2.6.1 Confirming the contents .....	2-20
2.6.2 Power off of the host machine .....	2-20
2.6.3 Installation procedure .....	2-20
2.7 Installing the Card Reader .....	2-22
2.7.1 Notice At Installation .....	2-22
2.7.2 Confirming the contents .....	2-22
2.7.3 Power off of the host machine .....	2-22
2.7.4 Installation procedure .....	2-22
2.7.5 Installing for imageWARE Accounting Manager .....	2-24
2.8 Installing the Original Holder .....	2-24

2.8.1 Checking Contents .....	2-24
2.8.2 Installation Procedure .....	2-24
2.8.3 Checking Contents .....	2-25
2.8.4 Installation Procedure .....	2-25
2.9 Installing the Reader Heater .....	2-25
2.9.1 Checking the Contents .....	2-25
2.9.2 Power off of the host machine .....	2-25
2.9.3 Installation Procedure .....	2-26
2.10 Installing the Cassette Heater .....	2-27
2.10.1 Checking Components .....	2-27
2.10.2 Power off of the host machine .....	2-28
2.10.3 Installation Procedure of the Cassette Heater .....	2-28
2.11 Installing the Deck Heater .....	2-30
2.11.1 Checking the Parts to Install .....	2-30
2.11.2 Turning Off the Host Machine .....	2-31
2.12 Installing the Deck Heater (Large Deck) .....	2-31
2.12.1 Checking the Parts to Install .....	2-31
2.12.2 Turning Off the Host Machine .....	2-32
2.13 Installing the Voice Guidance Kit .....	2-32
2.13.1 A point to keep in mind at installation .....	2-32
2.13.2 Checking the Contents .....	2-32
2.13.3 Power off of the host machine .....	2-33
2.13.4 Installation Procedure .....	2-33
2.14 Installing the Wireless Network Interface Adapter .....	2-39
2.14.1 Points to Note When Installing .....	2-39
2.14.2 Checking the Contents .....	2-39
2.14.3 Power off of the host machine .....	2-39
2.14.4 Installation Procedure .....	2-39
2.14.5 Affixing the Label .....	2-41

## 2.1 Making Pre-Checks

### 2.1.1 Selecting the installation space

iR5065 / iR 5055 / iR5075 / iR5075N / iR5065N / iR5055N

The conditions of the installation space include the following.

Preliminary inspection of the planned installation space would be desired before shipping the machine to the customer.

1. The power supply can be connected to a power outlet of 100 V +/- 10 V, 15 A or more. The host machine can be grounded.

Grounding target

- 1) Grounding terminal of power outlet
  - 2) Grounding terminal finished to category D
2. The temperature and humidity are within the range shown in the following figure. The area near the faucet, water heater, moisture chamber and refrigerator should be especially avoided.

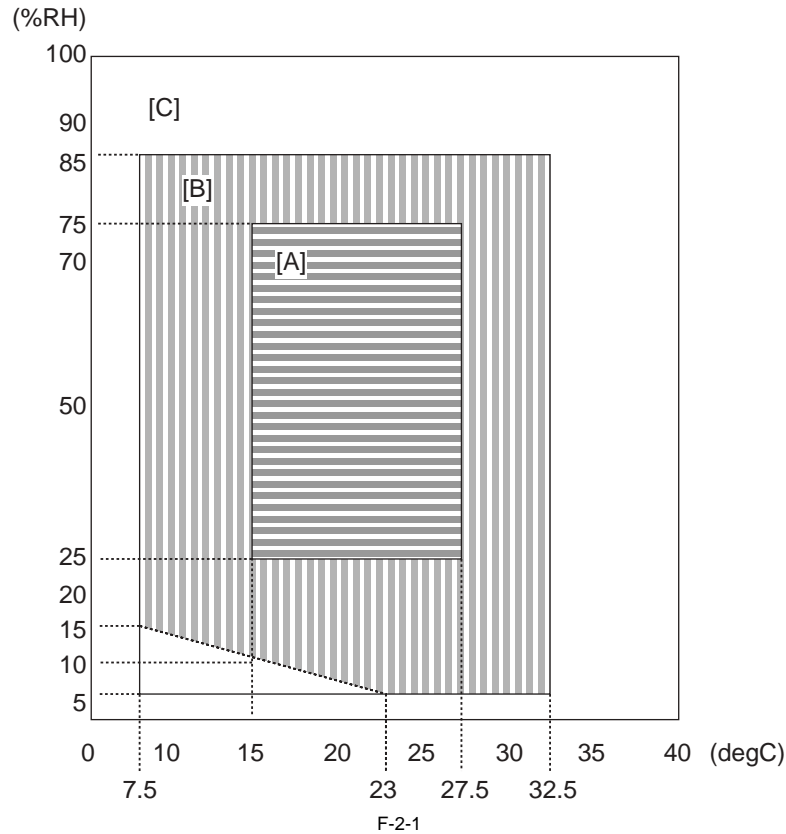

<Assured environmental zone>

[A]: A zone. All quality standard items are satisfied.

[B]: B zone. Some quality standard items are inferior to those in A zone or not satisfied.

[C]: C zone. Copying operation is performed normally without any safety issues, malfunction, and errors in display.

3. The area near the origin of fire, with full of dust and where ammonia gas generates should be avoided. In the case that the space is exposed to direct light, it is better to hang a curtain on the window.
4. Although the ozone level generating in using this equipment does not affect human bodies, long-hours operation in a poorly-ventilated room may cause some odor to be sensed. Ventilation should be done to keep a comfortable work environment.
5. The foot of the host machine should not get off the floor. The host machine should be kept in a horizontal status.
6. The host machine should be separated from the wall by 100 mm or more to keep a space sufficient for machine operation.
  - When installing the Copy Tray-L1

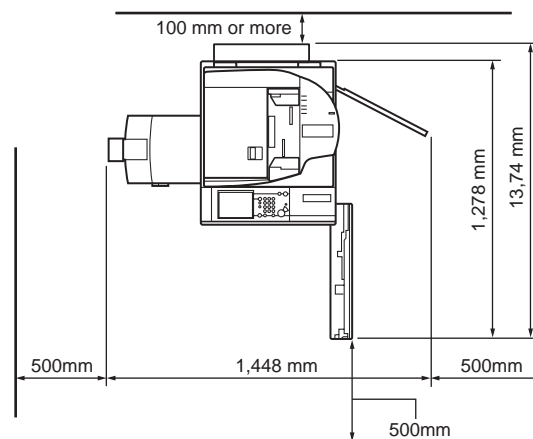

- When installing the Saddle Finisher-AD2 + Paper Folding Unit-E1 + Document Insertion Unit-E1 + Puncher Unit-AT1 + Paper Deck-AE1

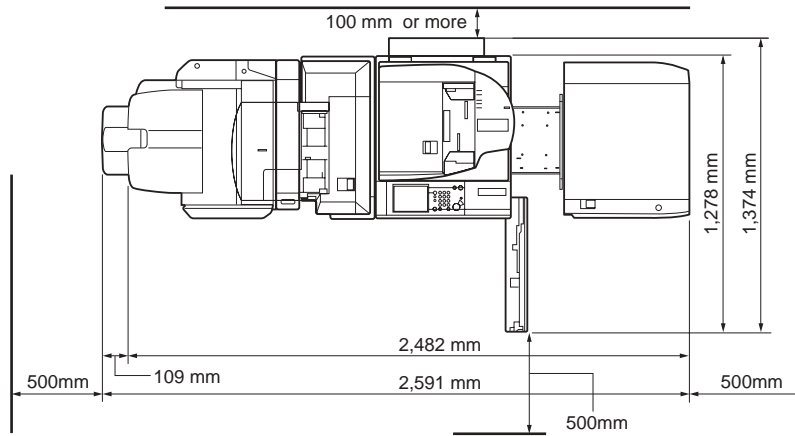

F-2-3

- 7. This equipment should be installed in a well-ventilated room, however not near the ventilating suction mouth in the room.
- 8. In the case that several machines are installed at the same area, this machine should be arranged so that this machine does not draw directly the exhaust air from the other machines. The life of the charging wire may be shortened, especially in a low-humidity environment.

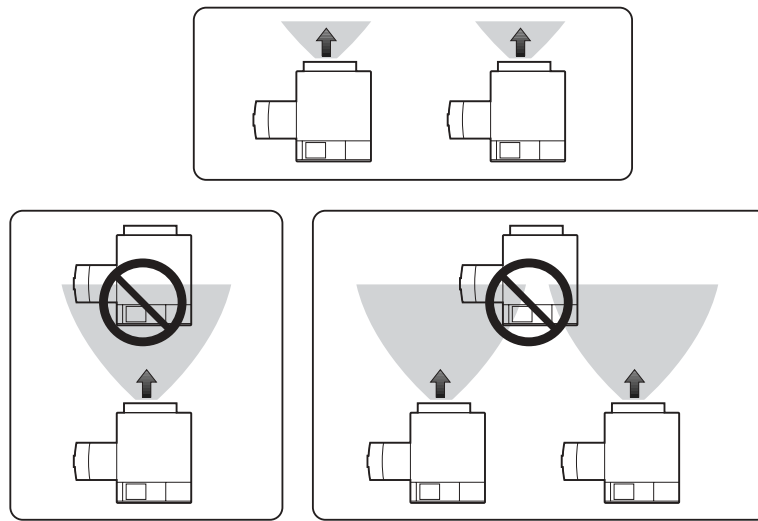

F-2-4

**2.1.2 Combination Table of Accessories**

iR5065 / iR 5055 / iR5075 / iR5075N / iR5065N / iR5055N



The following table shows the combination of accessories that are set at the right side of the host machine. When setting the accessories indicated in the table, refer to the table below and check the combination before the setup.

T-2-1

	Document Tray	Voice Guidance Kit	Card Reader
Document Tray	-	no	yes
Voice Guidance Kit	no	-	yes
Card Reader	yes	yes	-
yes: Available no: Unavailable			



2.1.3 Checking the Contents

iR5065 / iR 5055 / iR5075 / iR5075N / iR5065N / iR5055N

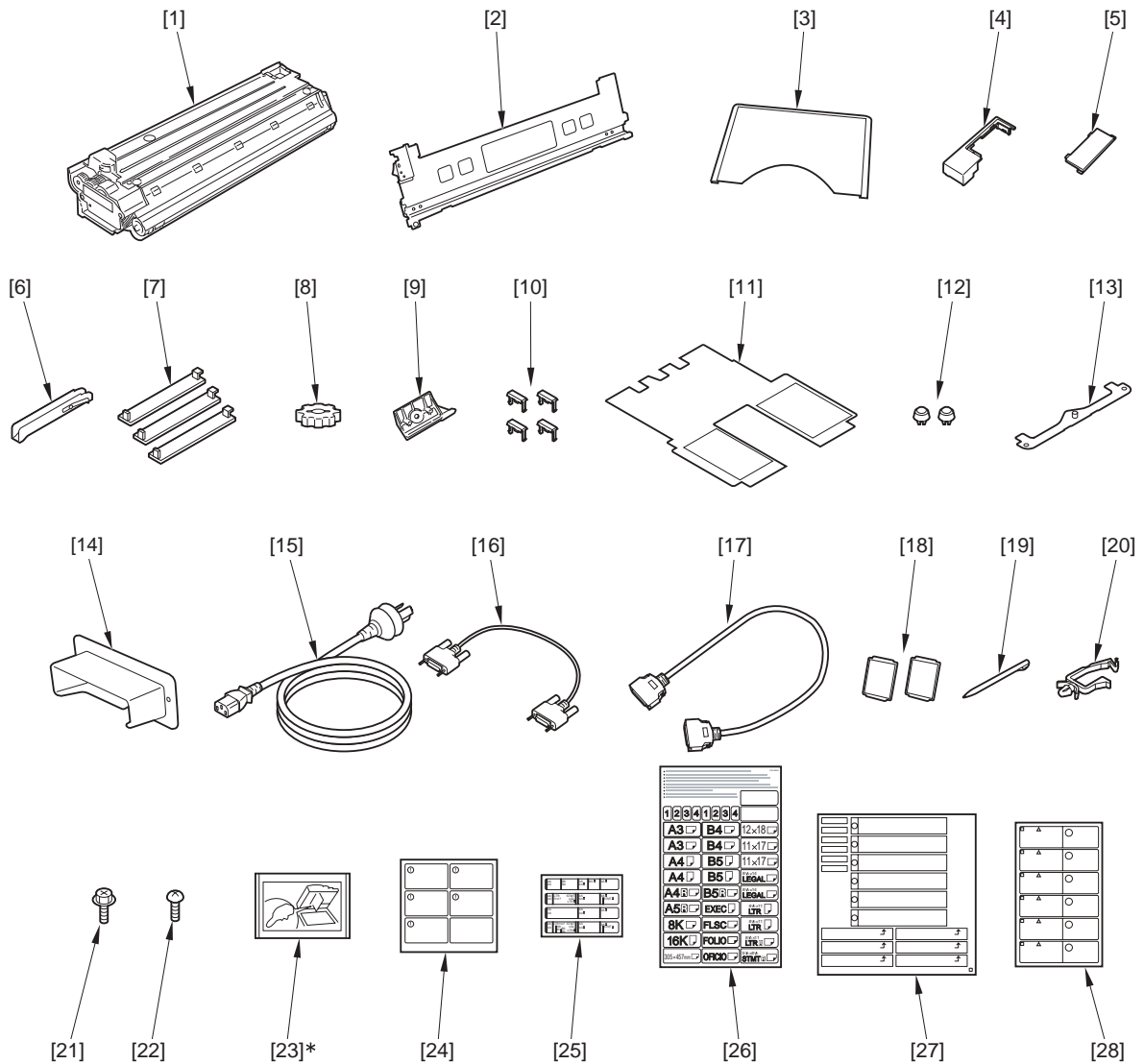

F-2-5

[1]	Developing assembly	1pc.	[2]	Developing assembly pressure unit	1pc.
[3]	Service book case	1pc.	[4]	Latch face cover	1pc.
[5]	Grip cover (small)	1pc.	[6]	Grip	1pc.
[7]	Grip cover (large)	3pc.	[8]	Drum rotation tool	1pc.
[9]	Deck pressure plate	1pc.	[10]	Inch-series block	4pc.
[11]	Base sheet	1pc.	[12]	One-touch supports	2pc.
[13]	Index paper attachment	1pc.	[14]	Cable Cover	1pc.
[15]	Power cable	1pc.	[16]	ADF communication cable	1pc.
[17]	Reader communication cable	1pc.	[18]	Paper size plate	2pc.
[19]	Touch pen	1pc.	[20]	Wire saddle	1pc.
[21]	Screw (RS tightening; M4X8)	1pc.	[22]	Screw (binding; M4X6)	1pc.
[23]*	Glass cleaning paper	1pc.	[24]	Shutdown label	1pc.
[25]	Document size label	1pc.	[26]	Paper size label	1pc.
[27]	Cleaning procedure label	1pc.	[28]	Cleaning position label	1pc.

\* Not used upon installation

Check the contents (advice book, CD, and others) against the following tables:

T-2-2

<b>Documentation</b>	<b>iR5075N iR5065N iR5055N</b>	<b>iR5075 iR5065 iR5055</b>
User's Guide	yes	yes
License agreement for software	yes	yes
Send Trial Kit	yes	yes
Release Notes	yes	no
Network Quick Start Guide	yes	no

T-2-3

<b>CD-ROM</b>	<b>iR5075N iR5065N iR5055N</b>	<b>iR5075 iR5065 iR5055</b>
Tutorial CD	yes	yes
ManualCD	yes	yes
MEAP Admin. CD-ROM	yes	yes
UFR II/PCL Driver/Utility CD-ROM	yes	no
iW MC CD-ROM	yes	no
Printer Guide CD-ROM	yes	no

## 2.2 Unpacking and Installation

### 2.2.1 Unpacking and installation procedure

iR5065 / iR 5055 / iR5075 / iR5075N / iR5065N / iR5055N

Take into account the following points when installing this equipment.



1. When transferring the host machine from a low-temperature to a warm place and installing it, dew condensation may occur around the pickup/feed assembly, leading to image faulty reproduction. Therefore, the host machine is unpacked and left for 1 hour or more to make it accustom to room temperature (Dew condensation: The phenomenon where water drops accumulate on the surface of metal when a metal material is moved from a low-temperature to a warm area and the moisture in the air surrounding the metal is quickly cooled)
2. When using stairways for carrying in and out from/to the installation space, take into account the following points.
  - 1) When lifting the host machine, do not use the left and right grips (3 locations) but hold the four corners at the bottom of the host machine.
  - 2) The mass of this equipment is approx. 230 kg. Make sure that four persons perform unpacking.
  - 3) Remove the ADF assembly, the fixing feed unit assembly and the duplexing unit assembly, and then separate them from the host machine before carrying in and out.

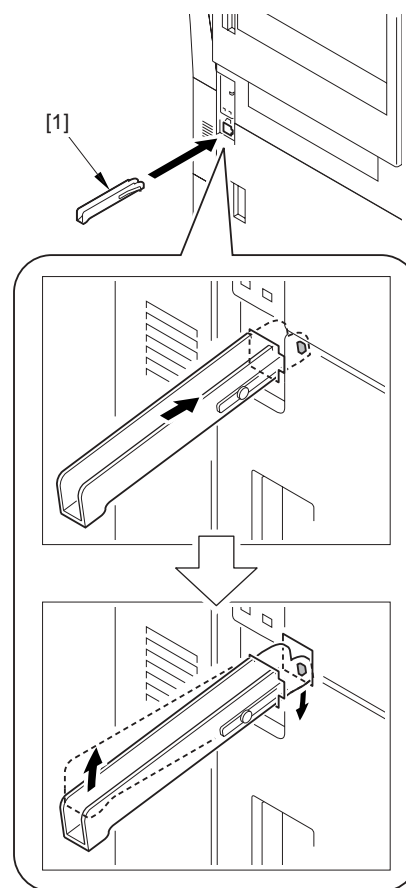

F-2-6

### 2.2.2 Unpacking

iR5065 / iR 5055 / iR5075 / iR5075N / iR5065N / iR5055N

- 1) Unpack the package, and remove the plastic bag.
- 2) Open the attached cardboard box, and then insert the 1 grip [1] that has been included to the front of the pickup side.



Be sure that the leaf spring of the grip is on the right side when inserting. Adverse insertion may cause the grip coming off while lifting the host machine.

- 3) Hold the 2 grips (front/rear) on the pickup assembly side [1] of the host machine, and then remove the 2 pads [2] while lifting the host machine a little. (Mass of the host machine: Approx. 230 kg)

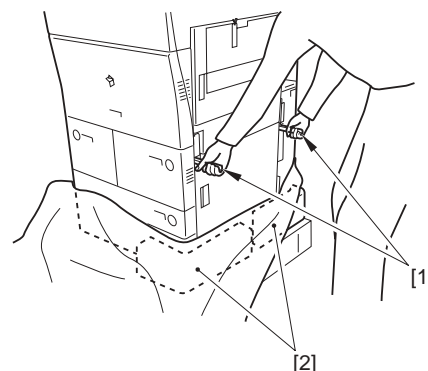

F-2-7

- 4) Hold the 2 grips (front/rear) on the delivery assembly side [1] of the host machine, and then remove the 2 pads [2] and the the plastic bag while lifting the host machine a little.

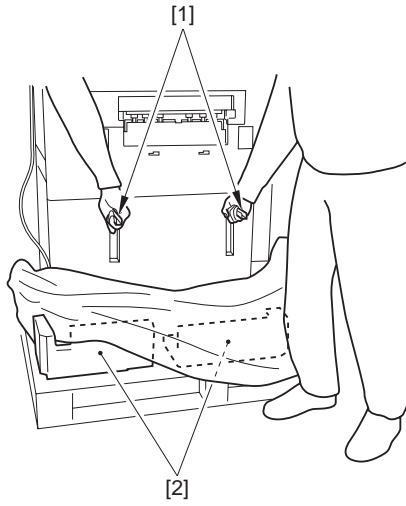

F-2-8

- 5) Remove the cardboard on the skid, and then take out the 2 slope plates [1] installed at the center of the skid.



If the slope plate is difficult to remove, displacement of the host machine to the rear edge of the skid makes operation easier.

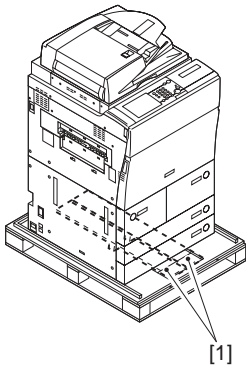

F-2-9

- 6) Remove the 2 pins taped to the back of the slope plate.  
7) Reverse the slope plate [1]. Match the pin hole of the skid against the pin hole of the slope plate, and then insert the 2 pins [2].

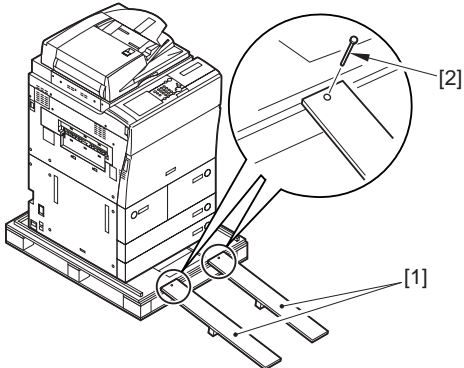

F-2-10

- 8) Hold the grip [1] of the host machine. Slide the host machine on the slope to get it down from the skid.



Be careful that the caster [2] does not fall out from the skid.

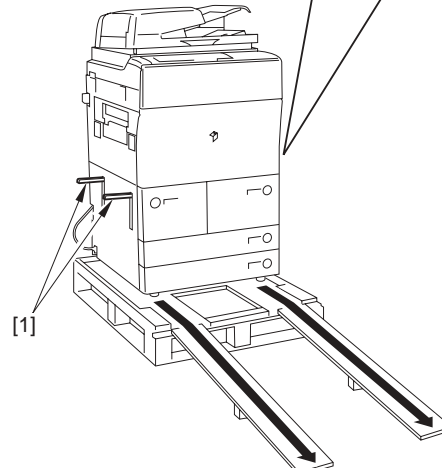
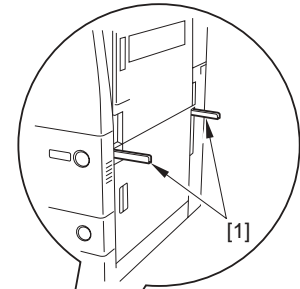
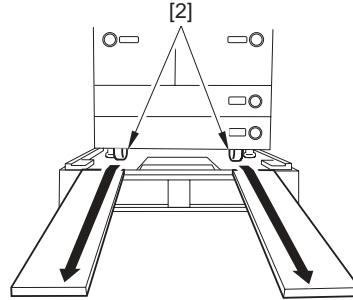

F-2-11

- 9) Remove the grip [1] of the host machine while pressing the leaf spring with a flathead screwdriver.

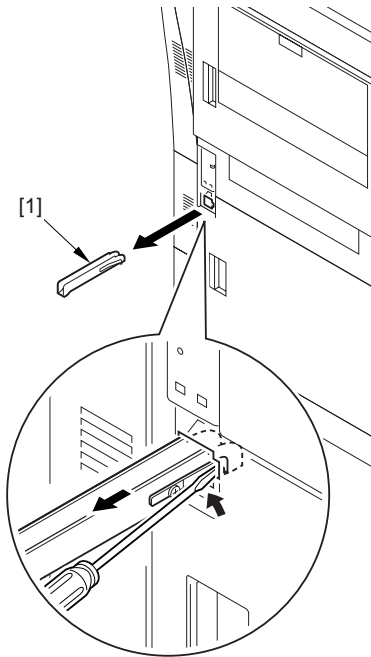

F-2-12

10) Remove the packing tape attached on the host machine.

### 2.2.3 Installation of Scanner

iR5065 / iR 5055 / iR5075 / iR5075N / iR5065N / iR5055N

- 1) Open the DADF, and remove the packing materials.
- 2) Remove the scanner fixing screw [1].

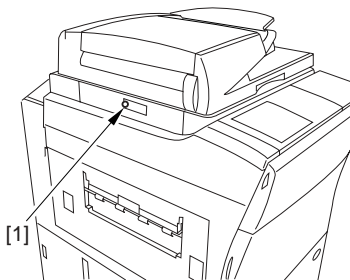

F-2-13

**!**  
The scanner fixing screw will be used when relocating the machine; thus, make sure a user stores away it.

- 3) Pull the release lever [1] and open the white sheet [2] in the direction of the arrow [A].

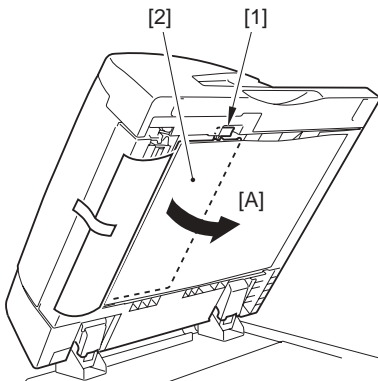

F-2-14

- 4) Remove the protection sheet.

**!**  
Make sure to tell user to keep the protection sheet in a safe place because it will be used when moving the host machine elsewhere.

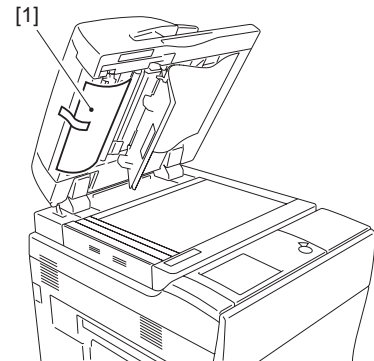

F-2-15

- 5) Close the white sheet.
- 6) Close the DADF.

### 2.2.4 Installation of Fixing Assembly

iR5065 / iR 5055 / iR5075 / iR5075N / iR5065N / iR5055N

- 1) Open the front cover.
- 2) Shift the fixing/feeder assembly release lever [1] in the direction of the arrow, and release the transfer/separation charging assembly. Slide the fixing/feeder unit [2] out toward the front.

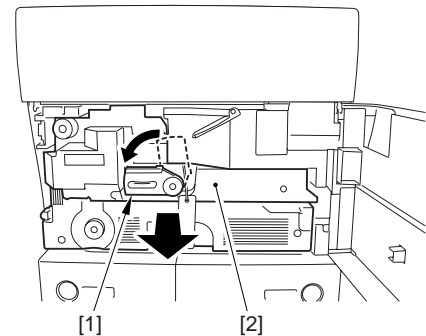

F-2-16

- 3) Remove the separation claw release member [1] and tag [2] attached onto the fixing/feeder assembly.

**!**  
Make sure to remove the foreign particles, such as tape glue on the feeder belt.

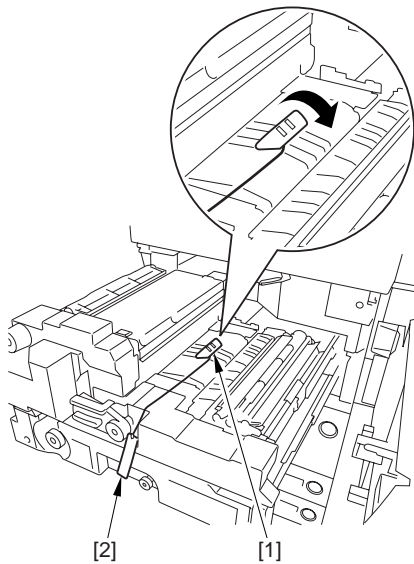

F-2-17

4) Peel off the tag tape to open the fixing/delivery assembly [1].

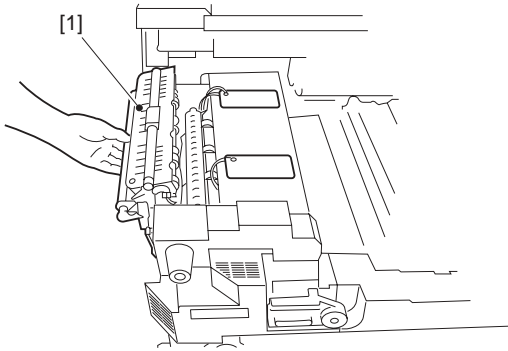

F-2-18

5) Remove the 2 fixing nip pressure release screws [1]. (The removed screws will not be used.)

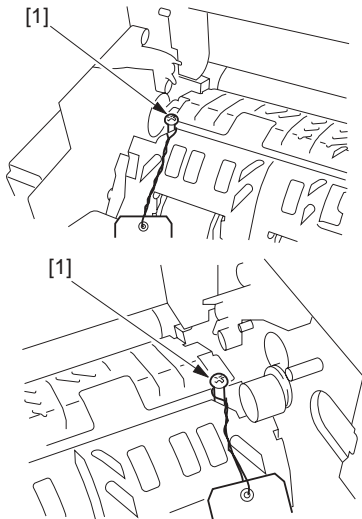

F-2-19

6) Close the fixing/delivery assembly.

### 2.2.5 Checking of Charging Assembly and Dustproof Glass

iR5065 / iR 5055 / iR5075 / iR5075N / iR5065N / iR5055N

1) Detach the feeder assembly front cover (right) [1].  
- 2 screws [2]

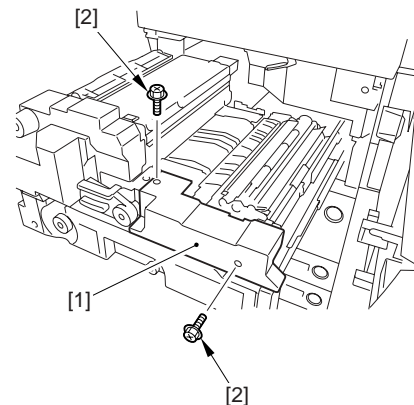

F-2-20

2) Remove the screw [1] and the mount [2], and disconnect the connector [3].

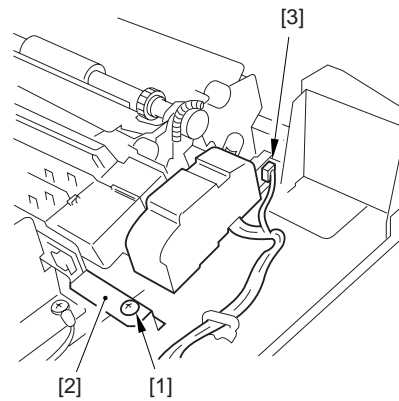

F-2-21

3) While holding the front and rear sides of the transfer/separation charging assembly [1], slide it in the [A] direction; then, remove it toward the [B] direction.

**⚠** Be careful not to cut the nylon wire by contacting the transfer/separation charging assembly with the transfer guide.

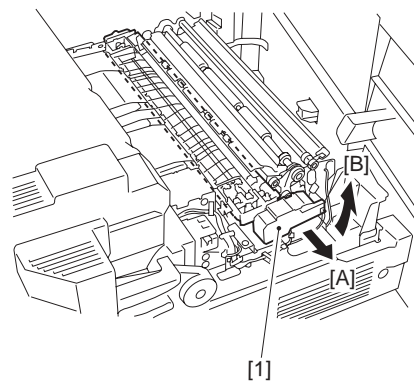

F-2-22

- 4) Check the transfer/separation charging assembly. If any dirt or paper powder is attached onto the assembly, clean it with alcohol solutions.
- 5) Mount the transfer/separation assembly using the steps to remove it but in reverse.
- 6) Attach the feeder assembly front cover (right) with the 2 screws (use the screws removed in the step 1).  
Put back the fixing/feeder assembly and the duplexing unit to the original positions (leave the fixing/feeder assembly release lever as it is).
- 7) Open the toner replacement cover.
- 8) Detach the toner replacement cover [1].  
- 2 screws [2]

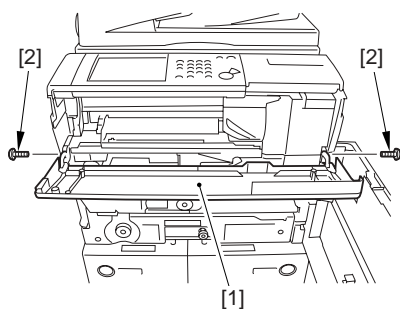

F-2-23

- 9) Detach the connector cover [1].  
- 1 screw [2]

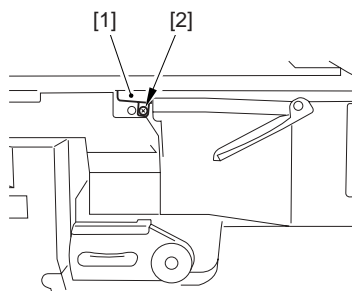

F-2-24

- 10) Remove the 2 screws [1] and disconnect the connector [2]; then, remove the primary fan duct [3].

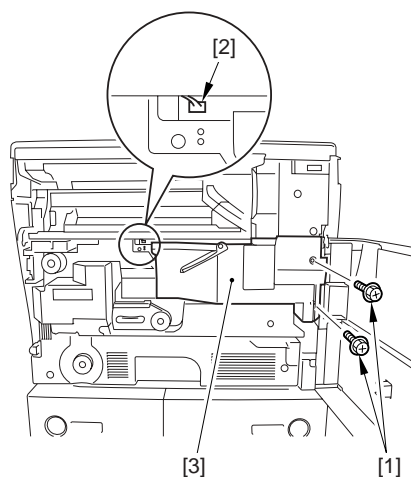

F-2-25

- 11) Loosen the screw [1] and shift the charging assembly mount [2] in the direction of the arrow; then, tighten the screw once again.  
12) Disconnect the connector [3], and remove the primary charging assembly [4].

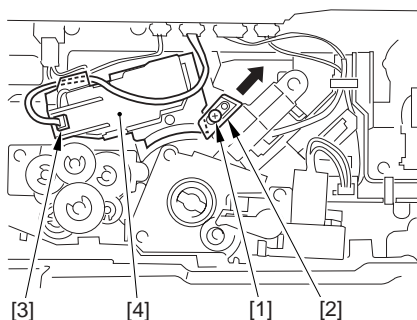

F-2-26

- 13) Check the primary charging assembly. If any dirt or paper powder is attached onto the assembly, clean it with alcohol solutions.  
14) Disconnect the connector [1] and remove the screw [2]; then, slide the pre-transfer charging assembly [3] pull out.

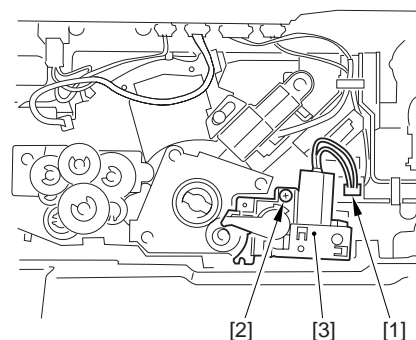

F-2-27

- 15) Check the pre-transfer charging assembly. If any dirt or paper powder is attached onto the assembly, clean it with alcohol solutions.  
16) Remove the dustproof glass [1].

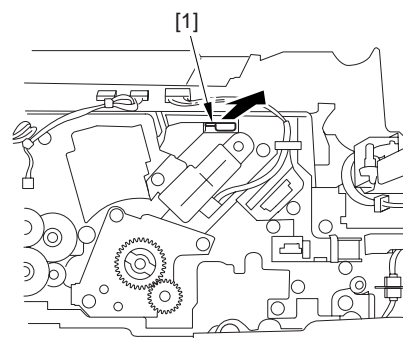

F-2-28

- 17) Check and clean the dustproof glass with a blower brush.  
18) Install the primary charging assembly, pre-transfer charging assembly and the dustproof glass in reverse order of the disassembly and secure them.

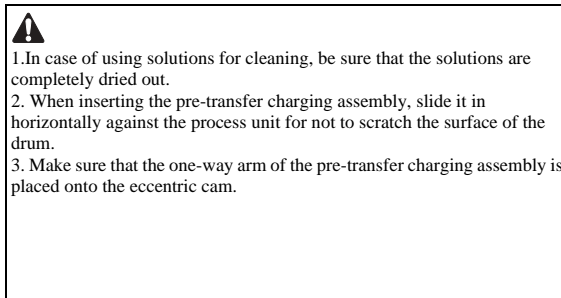

- 19) Attach the primary fan duct and the toner replacement cover using the steps to remove them but in reverse.

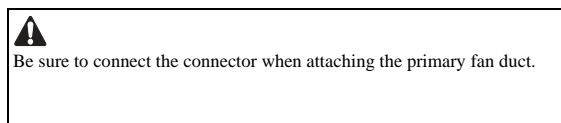

- 20) Lock the fixing/feeder assembly release lever, and close the front cover.

## 2.2.6 Installation of Developing Assembly

iR5065 / iR 5055 / iR5075 / iR5075N / iR5065N / iR5055N

- 1) Open the upper right cover [1], and remove the screw [2] from the door tape; then, open the cover further.

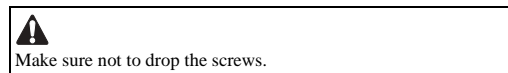

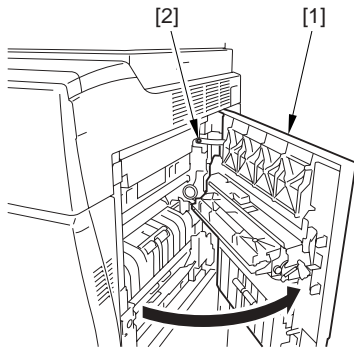

F-2-29

2) Remove the tape [1], and detach the hopper supply mouth cover [2].

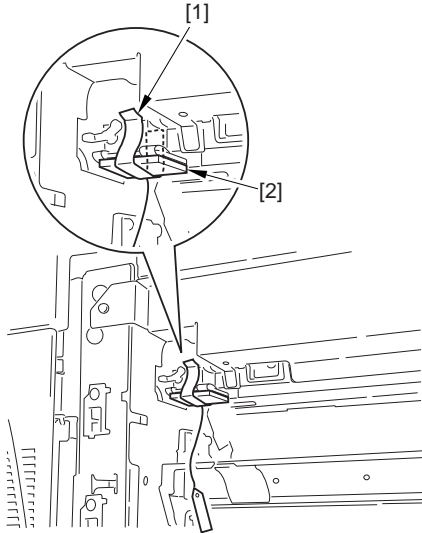

F-2-30

3) Take out the developing assembly from the packing box.  
 4) Rotate the developing cylinder gear [1] with hand and check if there are any cuts on the cylinder [2].

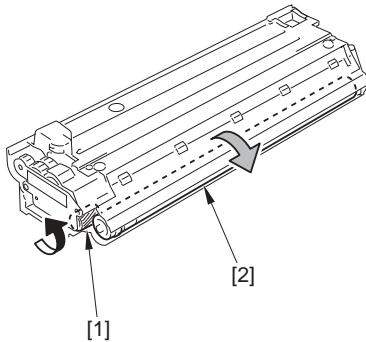

F-2-31

5) Hold the center (grip of the assembly) of the developing assembly [1] and install it.  
 Then, connect the connector [2].  
 Then, connect the connector [2].



When mounting the developing assembly, be sure not to contact the developing cylinder with the developing assembly mounting plate.

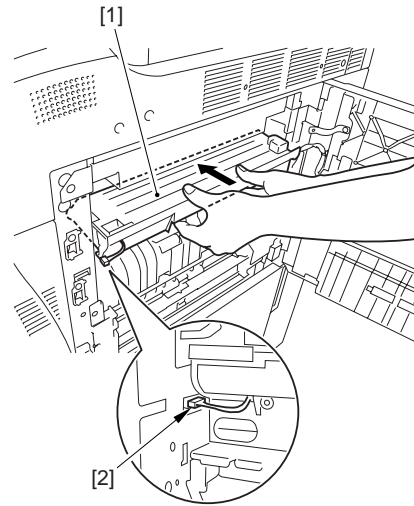

F-2-32

6) Fit the developing assembly pressure unit [1] to [2], and slide it in horizontally in the [A] direction; then, shift toward the [B] direction.  
 - 1 screw (binding; M4X6) [3]

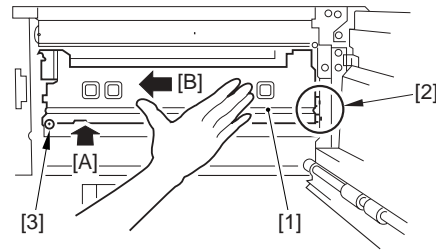

F-2-33

### 2.2.7 Installation of Pickup Assembly

iR5065 / iR 5055 / iR5075 / iR5075N / iR5065N / iR5055N

1) Remove the pickup roller pressure release spacer [1].



Remove the pickup roller pressure release spacer [1] while moving the front side of it upward after sliding the spacer toward the right.

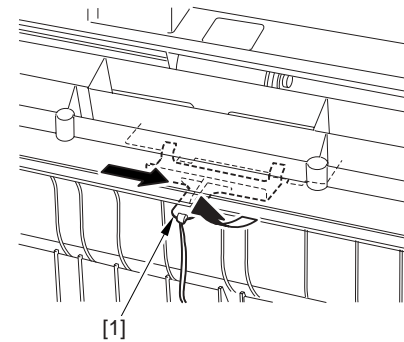



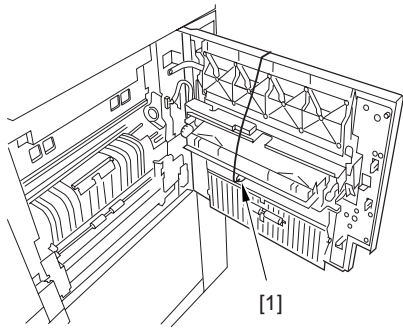

F-2-34

- 2) Pull out the right deck and cassette 3/4 halfway. Open the lower right cover and remove the pickup roller pressure release spacers [1].

**MEMO:**

When the deck and cassette are stored, the spacer is pressured and hard to remove. Thus, pull out the deck and cassette halfway to release the pressure.

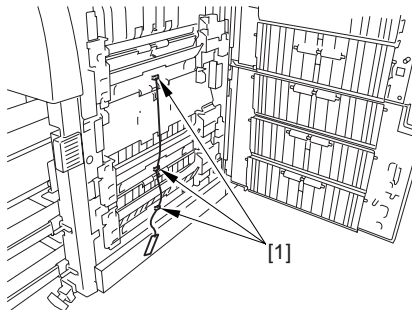

F-2-35

- 3) After removing each spacer, close the deck, cassette and lower right cover.
- 4) Attach the door tape of the upper right cover with the screw, and close the upper right cover.

**2.2.8 Attaching Deck Pressure Plate**

iR5065 / iR 5055 / iR5075 / iR5075N / iR5065N / iR5055N

- 1) Press the release button of the left deck and slide the left deck out.
- 2) Attach the deck pressure plate [1] with the screw (RS tightening; M4X8) [2].

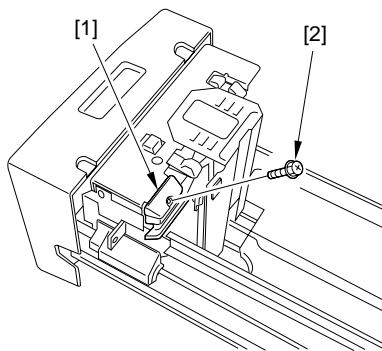

F-2-36

- 3) Close the left deck.

**2.2.9 Setting Toner Container**

iR5065 / iR 5055 / iR5075 / iR5075N / iR5065N / iR5055N



Do not shake the toner container.

If setting the toner container that has been shaken to the host machine, the toner overflow within the machine may occur.

By shaking the container, the toner fluidity increases. As a result, toner is supplied swiftly to the machine with the toner supply operation, causing the foregoing symptoms.

- 1) Take out the toner container from the packing box.
- 2) After opening the toner replacement cover [1], pull down the lock lever [2] in the direction of the arrow.

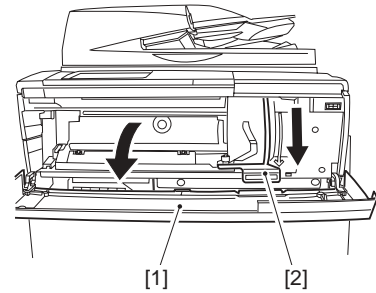

F-2-37

- 3) Hold the toner container [1] as shown in the figure below, and remove the cap [2] from the container by rotating the cap in the direction of the arrow.

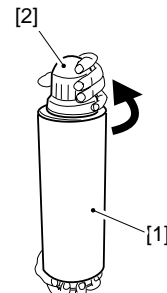

F-2-38

- 4) Hold the toner container with its mouth [1] at the right side, and set it into the supply case [2] of the host machine horizontally.

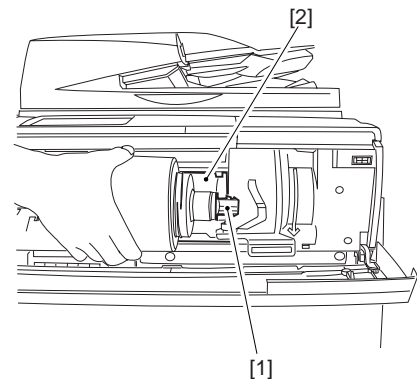

F-2-39

- 5) Slide the lock lever [1] upward to lock the toner container [2] in place.

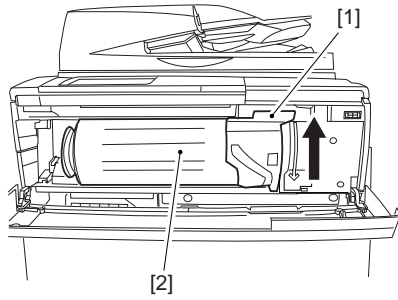

F-2-40

6) Close the toner replacement cover.



When turning on the main power switch without setting toner container, the toner level meter on the control panel shows 25 % or less. Make sure that the toner container is set in the host machine before turning on the main power switch.

### 2.2.10 Connecting the Cable

iR5065 / iR 5055 / iR5075 / iR5075N / iR5065N / iR5055N

1) Connect the ADF power cable [1] and attach the wire saddle [2].

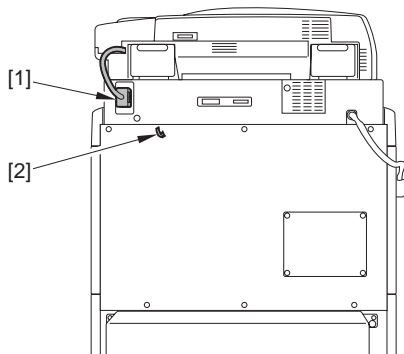

F-2-41

2) Connect the connector [1] of the ADF communication cable and the connector [2] of the reader communication cable.

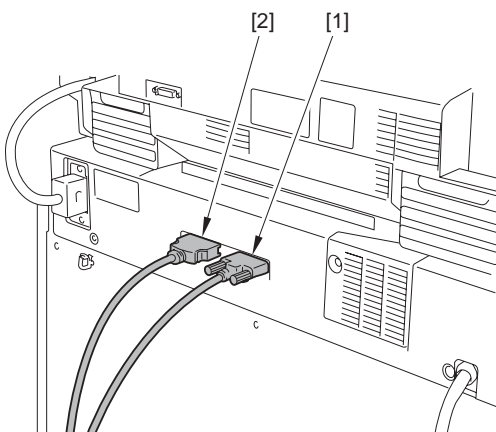

F-2-42

3) Put the ADF communication cable and the reader communication cable through the cable cover [1], and then remove the release paper on the cable cover and attach it on the position shown in the figure.

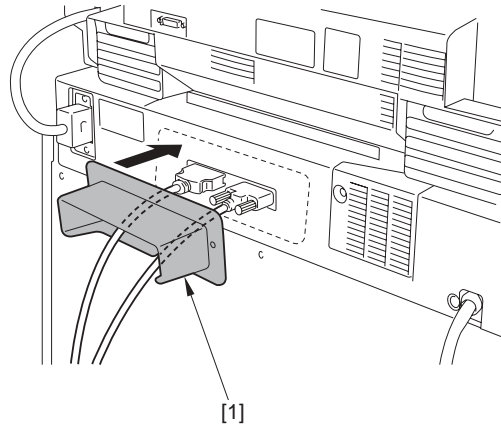

[1]

F-2-43

4) Connect the connector [1] of the ADF communication cable.

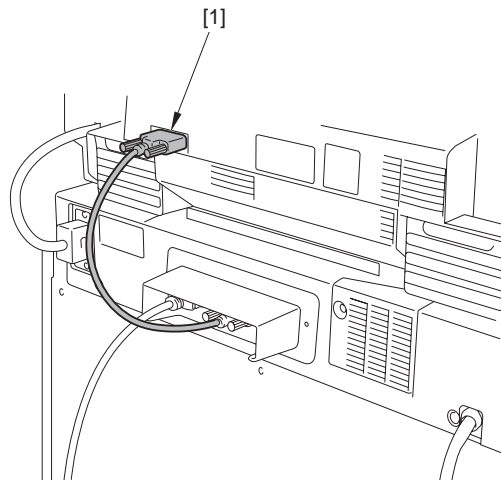

F-2-44

5) Connect the connector [1] of the reader communication cable and secure it with the wire saddle [2].

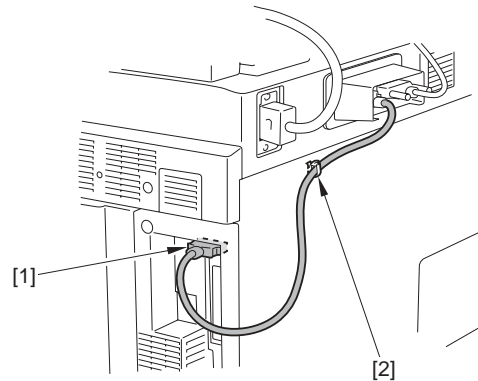

F-2-45

### 2.2.11 Checking the Environment Switch

iR5065 / iR 5055 / iR5075 / iR5075N / iR5065N / iR5055N

1) Make settings for environment switch [1] and the cassette heater switch [2] according to the environment of the installation site. In case the drum/cassette heaters are required to be turned on while the main power switch is turned off, make settings with the following 2 switches:

T-2-4

Drum heater	
ON	OFF
Environment switch ON Main power switch ON	Environment switch OFF Main power switch OFF

T-2-5

Cassette heater	
ON	OFF
Cassette heater switch ON Environment switch ON Main power switch OFF	Cassette heater switch OFF Environment switch ON Main power switch ON

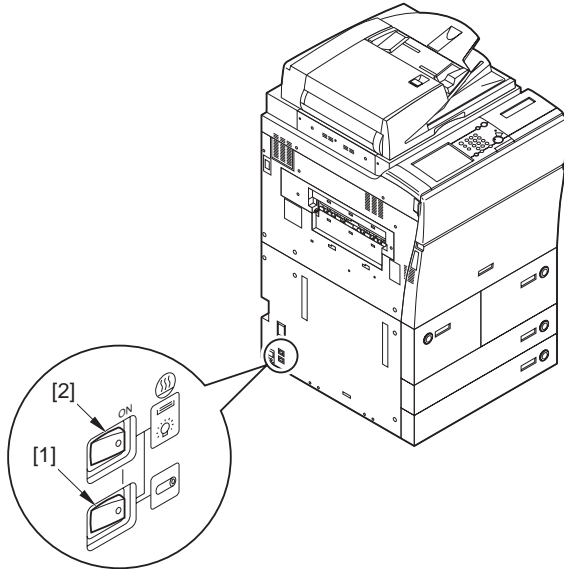

F-2-46

### 2.2.12 Attaching the Label

iR5065 / iR 5055 / iR5075 / iR5065N / iR5055N

#### <Attaching the cleaning position label>

- 1) Open the DADF [1].
- 2) Attach the cleaning position label [2] for the relevant language.

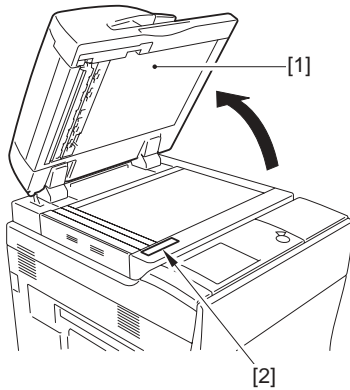

F-2-47

#### <Attaching the cleaning procedure label>

- 1) Pull the release lever [1] and open the white sheet [2] in the direction of the arrow [A].

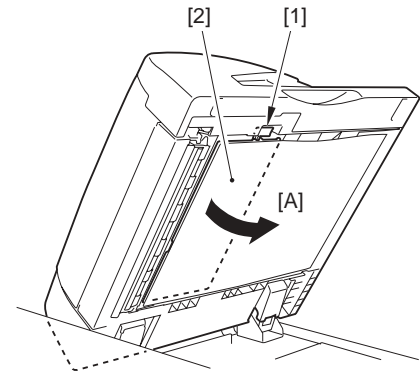

F-2-48

- 2) Attach the cleaning procedure labels [1] [2] for the relevant language.

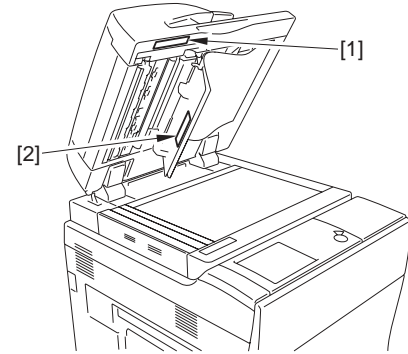

F-2-49

- 3) Remove the reading cleaning tool [1].

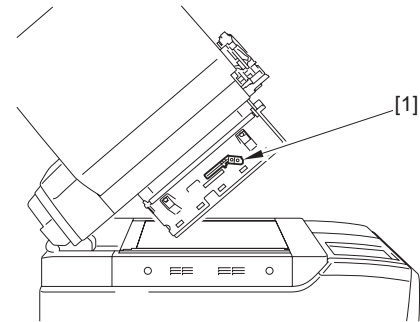

F-2-50

- 4) Attach the cleaning procedure label [1] for the relevant language.

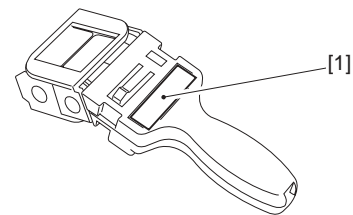

F-2-51

- 5) Put the detached parts back on by reversing the foregoing steps.
  - Reading cleaning tool
  - White sheet
- 6) Close the DADF.

### 2.2.13 Connecting the Power Cord

iR5065 / iR 5055 / iR5075 / iR5075N / iR5065N / iR5055N

- 1) Connect the power cable with the inlet on the main body.



Use the correct power code to match the location/area of installation. Make sure not to leave unused power code at the site.



-Be sure to attach the inch-series block firmly.  
-Go through this procedure only in case of not using inch-series paper.

### 2.2.14 Turning On the Main Power Switch

iR5065 / iR 5055 / iR5075 / iR5075N / iR5065N / iR5055N



Be sure to remove the packaging materials inside the cassette before turning on the main power switch.

- 1) Slide the duplexing unit out, and check to see that there is no foreign substances or damage in the unit.
- 2) Make sure that the main power switch is turned off, and then connect the power plug into the power outlet.
- 3) Turn on the main power switch.
  - The message 'Wait..' appears.

### 2.2.15 Toner Stirring

iR5065 / iR 5055 / iR5075 / iR5075N / iR5065N / iR5055N

After wait time, execute toner supply in service mode.

- 1) Enter service mode.
- 2) Select: COPIER > FUNCTION > INSTALL > TONER-S.
- 3) Check the message 'CHECK THE DEVELOPER' appears.
- 4) Check to see that the developing assembly is attached appropriately, and then press 'OK'.
  - It takes approx. 8 to 10 minutes to supply toner. The machine stops automatically after counting.
  - Make settings for the cassette by the completion of toner supply. (See media cassette settings.)



Be sure not to turn off the machine during its operation.

- 5) Press [Reset] to escape from service mode.

### 2.2.16 Media Cassette Settings

iR5065 / iR 5055 / iR5075 / iR5075N / iR5065N / iR5055N

- 1) Hold down the cassette release button to slide each cassette to the front.
- 2) Set the side guide [1] of each cassette onto the hole of the mark M [2] (A4/A3).

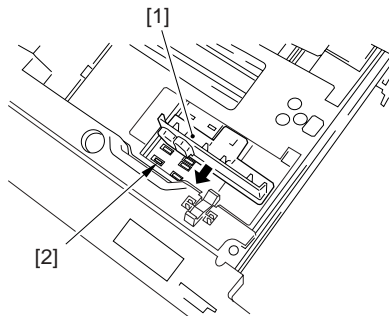

F-2-52

- 3) Attach the inch-series block from inside the cassette onto the hole of the mark A [1] (STMT-R) and the hole of the mark H [2] (LTR-R) so that they are hidden.

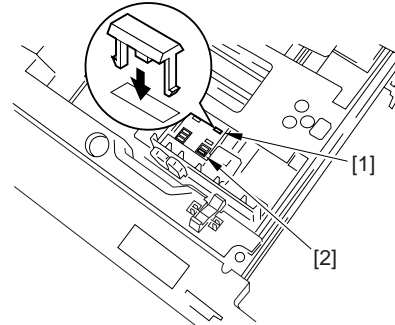

F-2-53

- 4) At customer's desire, configure the media cassette settings at service mode.
- 5) Place media in the right/left decks.
- 6) Close the right/left decks. Tear off the relevant media size label [1] from the mount sheet, and then attach it onto the media size plate of the deck.

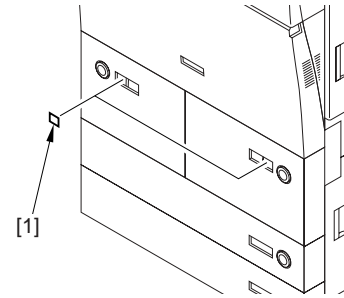

F-2-54

- 7) Hold down the release button, and then slide Cassette3 and 4 out.
- 8) Tear off the relevant media size label [1] from the mount sheet, and attach it onto the media size plate [2] of the cassette. Set the media size plate in the cassette.

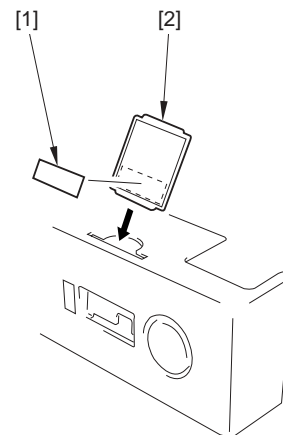

F-2-55

- 9) Close each cassette.

### 2.2.17 Index Paper Attachment

iR5065 / iR 5055 / iR5075 / iR5075N / iR5065N / iR5055N

- 1) Determine the cassette for index paper from either of Cassette 3 or 4.
- 2) Press the release button of the cassette you determined to slide it toward the front.
- 3) Fit the 2 one-touch supports [1] onto the holes [2] of the cassette, and press the pin into the hole to fix them in place.
- 4) Fit the holes of the index paper attachment [3] on the one-touch supports [1].
- 5) Set the base sheet [4] on the cassette.

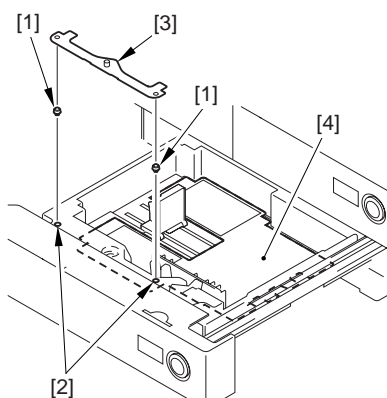

F-2-56

- 6) Close the cassette.

### 2.2.18 Changing the Media Size of the Front Deck (Left/ Right)

iR5065 / iR 5055 / iR5075 / iR5075N / iR5065N / iR5055N

- 1) Hold down the release button to slide the deck out.
- 2) Remove one of each screw [4] of the trailing edge plate [1], the left guide plate [2] and the right guide plate [3]. Secure the each guide plate in place on user desired size.  
Factory setting: A4 size
- 3) After changing the size, place the paper and set the deck into the host machine.

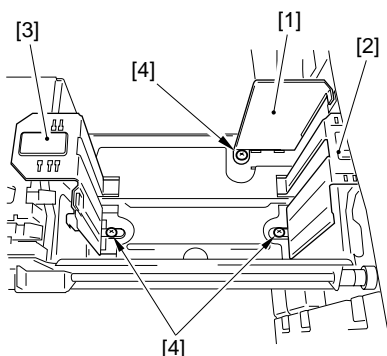

F-2-57

- 4) Attach the new media size label onto the media size plate of the deck.
- 5) In case the size is changed, register the front deck media size in service mode.  
Right deck: COPIER > OPTION > CST > P-SZ-C1  
Left deck: COPIER > OPTION > CST > P-SZ-C2  
A4=6, B5=15, and LTR=18

### 2.2.19 Image/Operation Check in User Mode

iR5065 / iR 5055 / iR5075 / iR5075N / iR5065N / iR5055N

- 1) Press [Reset] twice and return to the main screen. Using test sheet, check the copy operation and copy image.
  - Copy operation: Check to see that the copy operation is appropriate.
  - Duplexing copy operation: Check to see that the paper feeding at the duplexing unit is appropriate.
  - Pickup operation: Check to see that the paper is fed normally from the each pickup slot.
  - Operation noise: Check to see that there is no abnormal noise.
  - Fixed ratio reproduction: Check the image quality for each fixed ratio reproduction.
  - Multiple copies: Check to see that the copy operation for a specified number of sheets is appropriate.
  - Check to see that print images picked up from each cassette/deck are within the scope of specifications.  
Specification for image left end margin: 2.5 +/-1.5mm  
Specification for image leading edge margin: 4.0-1.5/-1.0mm

In case the values is/are out of the scope of the specifications, see 'Adjustment of image left end margin' and 'Adjustment of image leading edge margin'.

- \* In case there is a difference in density between the left and the right of the image, adjust the height of the primary charging wire at the rear side to correct it.

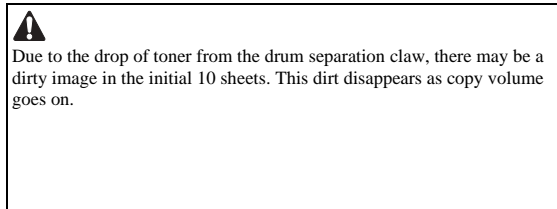

- 2) Check with the user to find out the size of paper to use, and set the paper size of each cassette, and attach the size label to the cassette size plate.
- 3) Close each cassette.

### 2.2.20 Adjustment of Image Left End Margin

iR5065 / iR 5055 / iR5075 / iR5075N / iR5065N / iR5055N

#### <Cassette 3/4>

- 1) Hold down the cassette release button, and then slide Cassette 3 and 4 out.
- 2) Loosen the 2 fixing screws [1] at the left/right of the cassette.

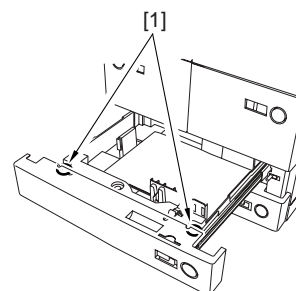

F-2-58

- 3) Adjust the position of the cassette body [1] by shifting it to the front or the rear.  
Shift to the rear = Decreases the left end margin  
Shift to the front = Increases the left end margin

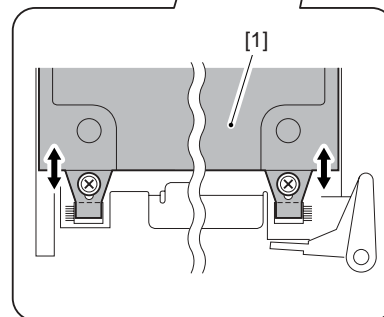
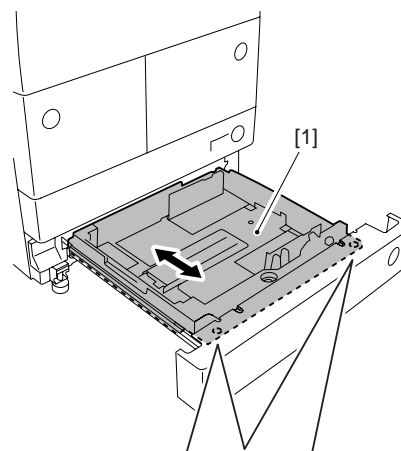

F-2-59

- 4) Tighten the 2 screws loosened at the step 2)
- 5) Close Cassette 3/4
- 6) Check that the left margin of the copied image from Cassette 3/4 is as follows : L1=2.5-/+1.5mm

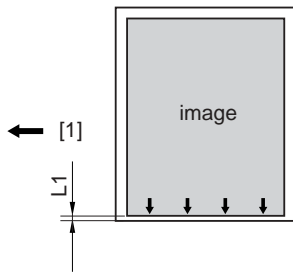

F-2-60

[1] Feeding direction of paper

7) After the adjustment, perform the following in service mode:  
Cassette 3

COPIER > FUNCTION > CST > C3-STMTR/A4R

Register the basic value for paper in Cassette 3:

7-1) Set the STMTR/A4R size papers in Cassette 3, and align the side guide plate with the STRTR/A4R width.

7-2) Select C3-STMRT/A4R to highlight it and pressing [OK] key registers the numerical value after auto adjustment.

Cassette 4

COPIER > FUNCTION > CST > C4-STMTR/A4R

Perform the same operation as Cassette 3

<Front Deck Left/Right>

- 1) Press the set release button to pull out the front deck left/right toward the front.
- 2) Loosen the 2 screws [2] and the 2 fixing screws [3] of the deck front cover [1].

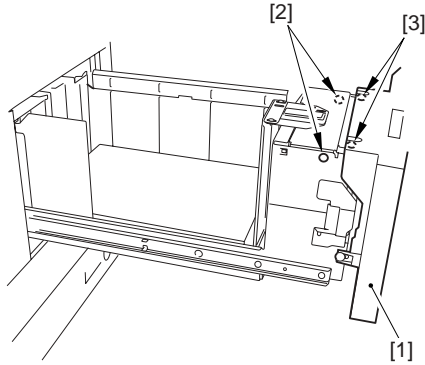

F-2-61

- 3) Move the cassette guide assembly [1] toward either the front or the back and perform adjustment.  
Move the guide plate toward the back = the left margin is reduced  
Move the guide plate toward the front = the left margin is increased

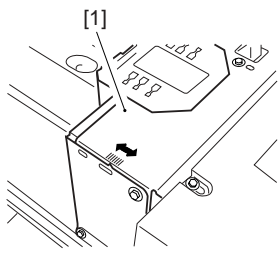

F-2-62

- 4) Tighten the 4 screws loosened at the step 2)
- 5) Close the front deck left/right
- 6) Check that the left margin of the copied image from the front deck left/right is as follows :  $L1=2.5 \pm 1.5\text{mm}$

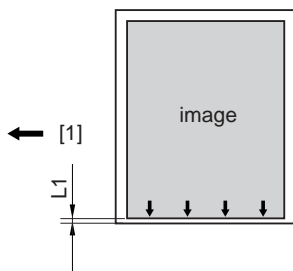

F-2-63

[1] Feeding direction of paper

<Manual Feeder Tray>

- 1) Open the manual feed tray.
- 2) Move the side guide plate [1] to the center, and loosen the 2 screws [2] for the slide guide to adjust the position of the slide guide.  
Move the slide guide toward the back = the left margin is reduced  
Move the slide guide toward the front = the left margin is increased

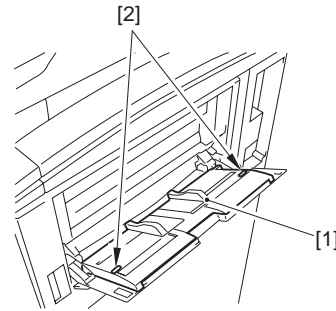

F-2-64

- 3) Tighten the 2 screws loosened at the step 2)
- 4) Close the manual feed tray.

<Duplexing Feeder Unit>

- 1) Make the left margin of the 2nd sided image as  $L1=2.5 \pm 2.0\text{mm}$  by selecting the following in service mode:  
COPIER > ADJUST > FEED-ADJ > ADJ-REFE  
Make the numerical value smaller = the left margin is reduced  
Make the numerical value larger = the left margin is increased (1mm shift by changing every 10 in the setting value)

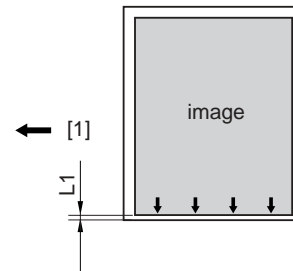

F-2-65

[1] Feeding direction of paper

2.2.21 Adjustment of image leading edge margin

iR5065 / iR 5055 / iR5075 / iR5075N / iR5065N / iR5055N

- 1) Select the following in the service mode: COPIER > ADJUST > FEED-ADJ > REGIST
- 2) Change the setting value to adjust.  
(Changing the setting value by 10 moves the image by 1 mm. Increasing the value moves the image toward the leading edge direction.)
- 3) Check that the leading edge margin of the image picked up from each cassette/deck is as follows:  $L1 = 4.0 \pm 1.5/-1.0 \text{ mm}$ .

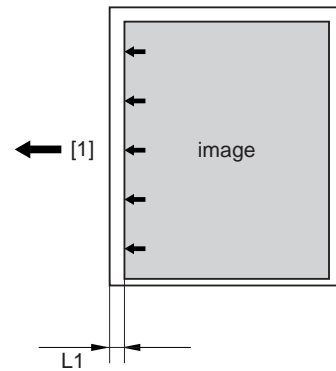

F-2-66

[1] Feeding direction of paper

2.2.22 Mounting of the Host Machine

iR5065 / iR 5055 / iR5075 / iR5075N / iR5065N / iR5055N

<Storing of the drum rotational tool and the grip>

- 1) Detach the lower rear right cover [1].

- 2 screws [2]

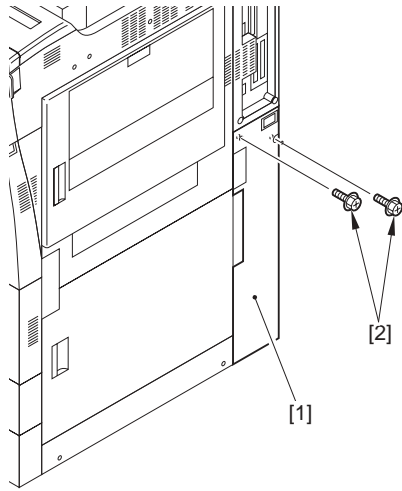

F-2-67

- 2) Store the following parts:
- Drum rotational tool [1]: store it along with the collecting toner cap to the hole of the pullout grip at the top of the collecting toner case [2].
  - Grip: insert to the grip storing area [3]

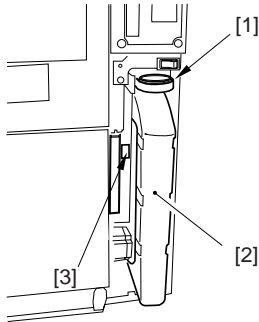

F-2-68

**!**  
 If pulling out the pullout grip fully, it makes the drum rotational tool and the cap fail to be inserted.  
 It is easy to insert them if pulling the pullout grip at moderate position shown in the figure below.

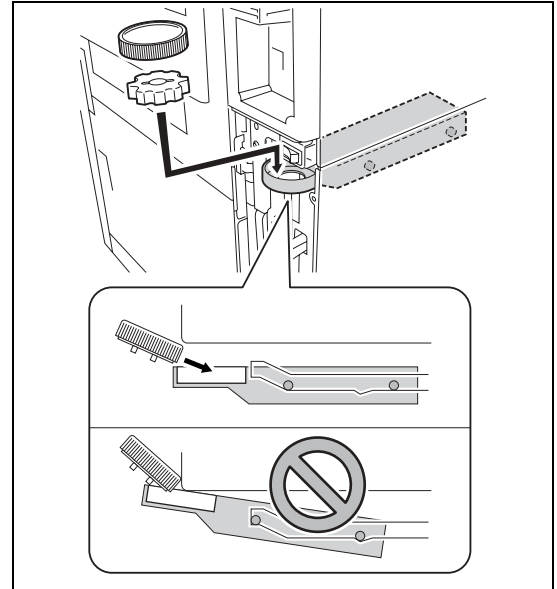

- 3) Attach the lower rear right cover removed in the step 1).

**<Attaching of the grip cover>**

- 1) Attach the grip cover (small) [1] to the latch face cover [2].

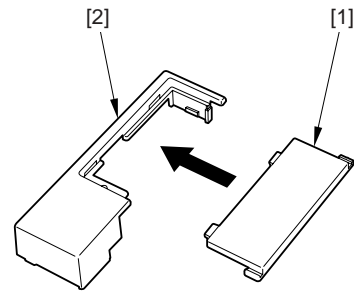

F-2-69

- 2) Attach the 3 grip covers (large) [1] and the cover [2] that was attached in the step 1).

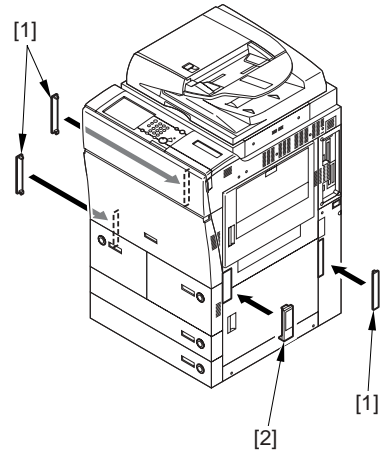

F-2-70

**<Attaching of the service book case>**

- 1) Peel off the two-sided tape located at the back of the service book case [1] to attach to the bottom plate of the host machine.



Be sure that the front side of the service book case is exposed for 6mm from the front side of the bottom plate [2] of the host machine when attaching the service book case.  
 In case of attaching the service book case without any margin exposed from the bottom plate, it will cause the service book case to run into the rail of the paper deck when mounting the paper deck later.  
 Be sure to attach the paper deck first and then attach the service book case in case of mounting the paper deck and attaching the service book case at the same time.

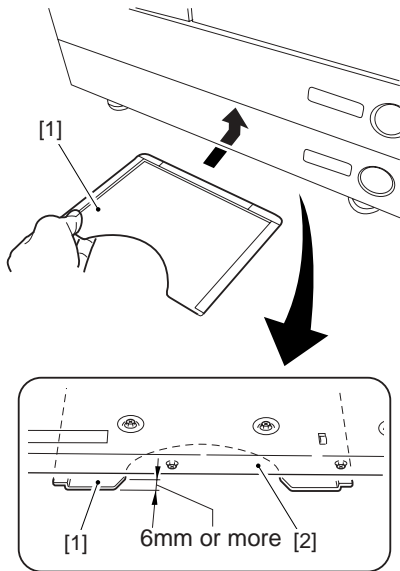

- Position forbidden to attach the service book case**
- Inside the machine (inner side of the front cover)
  - Position to block off the louver area
  - Position to block off the grip area

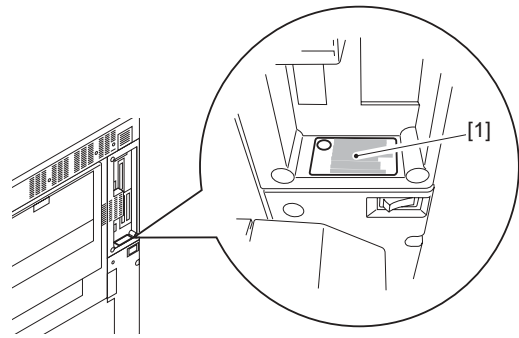

F-2-71

**<Attaching of the document size label>**

- 1) Set the document size guide plate [1] in A4/A3 position. Align the [A] tab of the document side guide plate with the A4/A3 indication of the document size label [2] and affix the label.

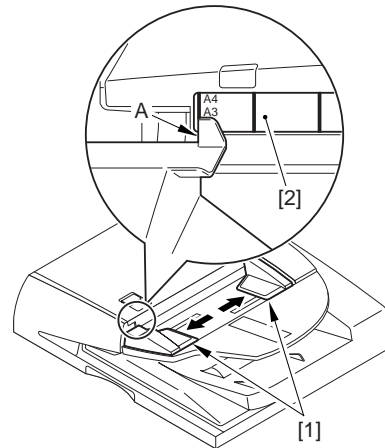

F-2-72

**<Attaching of the touch pen>**

- 1) Set the touch pen [1] on the control panel.

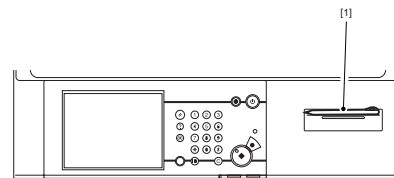

F-2-73

**<After installation of the host machine>**

- 1) Clean around the machine.
- 2) Move the host machine to the specified position and fix it in place with the 2 adjusters.

**MEMO:**

The adjusters may be too hard to turn by hand. In such case, use a screwdriver to turn.

**<Attaching of the shutdown label>**

- 1) Put the appropriate language shutdown label [1] on the indicated position.



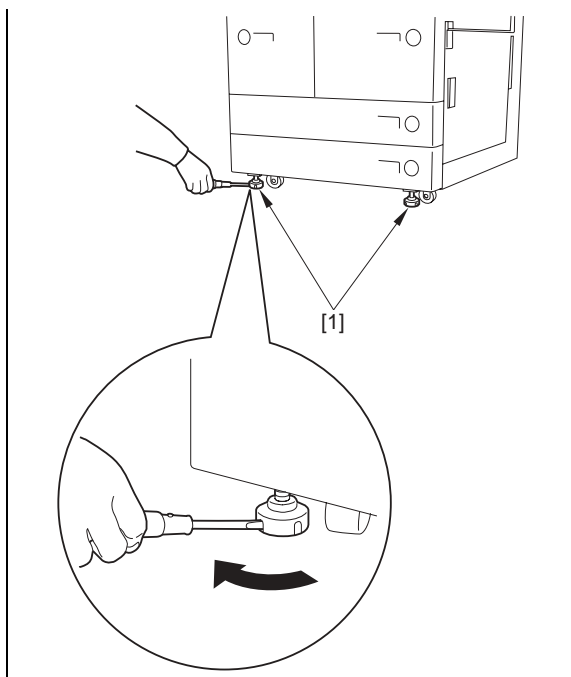

- 3) Fill in necessary information on the service book and store it to the service book case.

## 2.3 Checking the Connection to the Network

### 2.3.1 Overview

iR5065 / iR 5055 / iR5075 / iR5075N / iR5065N / iR5055N

The information in this section applies when connecting the host machine to a network.

If the user's network is in TCP/IP environment, use the PING command to see that the network settings are correct.

There is no need to check the settings using the PING command if the user's network is in an IPX/SPX or Apple Talk environment.

### 2.3.2 Checking the Connection to the Network

iR5065 / iR 5055 / iR5075 / iR5075N / iR5065N / iR5055N



The following steps apply only if the machine is connected to a network.

- 1) Perform the shutdown sequence so that the main power can be turned off.
- 2) Connect the network cable to the host machine, and turn on the main power switch.
- 3) Inform the on-site system administrator that the installation work of the host machine is complete, and also ask him/her to setup the host machine for networking.



To set up the machine for networking, it is necessary to enable [ON] for the following item in Initial Additional Functions :



> [System Settings] > [Network Setting] > [Change Setting/Display Connection Confirm]



In case of reentering the IP address, turning off and then on the main power is required in order to be enabled.

- 4) Perform the shutdown sequence so that the main power can be turned off.
- 5) Turn on the main power switch.

### 2.3.3 Using the Ping Command

iR5065 / iR 5055 / iR5075 / iR5075N / iR5065N / iR5055N

- 1) Make the following selections:  > [System Settings] > [Network Settings] > [TCP/IP Settings] > [Ping Command]
- 2) Using the keypad on the control panel, type in the correct IP address set in [Network Connection], and press the Execute key.  
If successful, the message 'Response from host' will appear so that you can check that the IP address is valid; otherwise, the message will read 'No response from host'

### 2.3.4 Making a Check Using the Remote Host Address

iR5065 / iR 5055 / iR5075 / iR5075N / iR5065N / iR5055N

You can execute the PING command using the appropriate remote host address to see if a connection to the network is available.

Remote host address: the IP address of a PC terminal connected to the TCP/IP network to which the machine is also connected.

- 1) Inform the system administrator that you are going to check the network connection using the PING command.
- 2) Check with the system administrator to find out the remote host address.
- 3) Add the appropriate remote host address to the PING command.
  - If the message is 'Response from host', the connection to the network is normal.
  - If the message is 'No response from host', the machine is not correctly connected to the network. Start the troubleshooting work in the next section.

## 2.4 Troubleshooting the Network

### 2.4.1 Troubleshooting the Network

iR5065 / iR 5055 / iR5075 / iR5075N / iR5065N / iR5055N

The following information applies only when the machine is connected to a network.

If attempts to connect to the network fail, suspect the following:

- The machine's TCP/IP settings are wrong.
- The user's network is faulty.

To find out which, go through the following:

### 2.4.2 Checking the Connection of the Network Cable

iR5065 / iR 5055 / iR5075 / iR5075N / iR5065N / iR5055N

- 1) Check to be sure that the network cable is correctly connected to the Ethernet port.
  - If the connection is correct, make the next check.
  - If the connection is wrong, correct it and run the check once again using the remote host address.

### 2.4.3 Making a Check Using a Loopback Address

iR5065 / iR 5055 / iR5075 / iR5075N / iR5065N / iR5055N

A loopback address comes back before reaching the network PCB. By executing the PING command using the address, you can find out whether the machine's TCP/IP settings are correct.

- 1) Add the appropriate loopback address (127.0.0.1) to the PING command.
  - If the message is "No response from host," check the machine's TCP/IP settings, and execute the PING command once again.
  - If the message is "Response from host," make the next check.

### 2.4.4 Making a Check Using a Local Host Address

iR5065 / iR 5055 / iR5075 / iR5075N / iR5065N / iR5055N

The "local host address" is the IP address of the machine, and the address comes back after reaching the network PCB. By executing the PING command using the address, you can find out whether the network PCB is free of a fault.

- 1) Add the IP address of the machine to the PING command.
  - If the message is "No response from host", go through the following and execute the PING command once again.
  - The machine's IP address may be wrong: Check the machine's IP

address settings, and check with the system administrator to see if the assigned IP address is a valid one.

- The connection of the network PCB may be wrong: Check the connection of the network PCB once again.
  - The network PCB may be faulty. Try replacing it.
- If the message is "Response from host", suspect a problem in the user's network environment. Report to the system administrator for appropriate action.

## 2.5 Relocating the Machine

### 2.5.1 Operation for Moving the Machine

iR5065 / iR 5055 / iR5075 / iR5075N / iR5065N / iR5055N

After installing the host machine, when moving it to the other place, execute the following operation to prevent the scanning glass from getting scratched.

- 1) Open the DADF.
- 2) Pull the release lever [1] and open the white sheet [2] in the direction of the arrow [A].

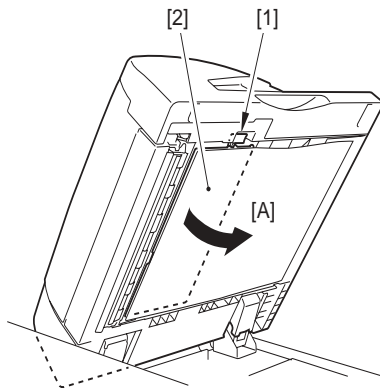

F-2-74

- 3) Attach the protective sheet [1].

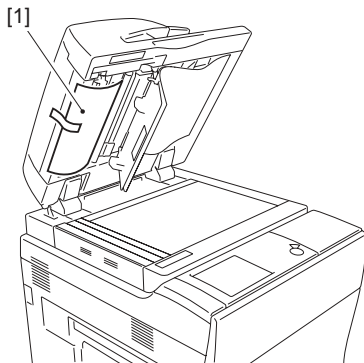

F-2-75

**⚠** Be sure to attach the protective sheet. Otherwise, it may affect the quality of image.

- 4) Close the white sheet.
- 5) Close the DADF.

## 2.6 Installing the Copy Tray

### 2.6.1 Confirming the contents

iR5065 / iR 5055 / iR5075 / iR5075N / iR5065N / iR5055N

<Copy Tray L1>

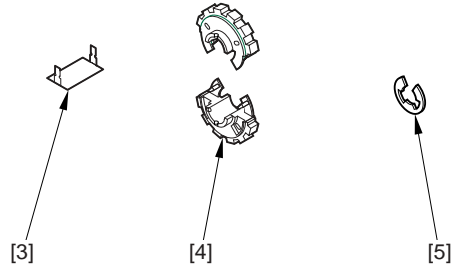
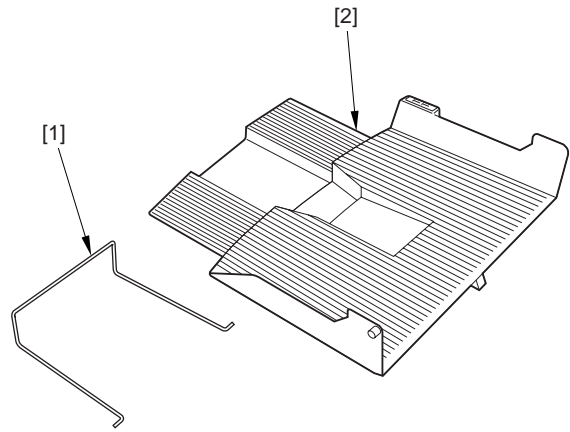

F-2-76

[1]	Delivery Bar	1 pc.
[2]	Delivery Tray	1 pc.
[3]	Magnet plate	1 pc.
[4]	Delivery roll	2 pc.
[5]	E ring	1 pc.

### 2.6.2 Power off of the host machine

iR5065 / iR 5055 / iR5075 / iR5075N / iR5065N / iR5055N

**⚠ How to turn off the main power**  
 When turn off the main power, implement the following steps to protect the hard disk of this product.

- 1) Push the control panel power switch for 3 sec or more.
- 2) Operate the touch panel following the instruction on the screen of shutdown sequence in order to be ready to turn off the main power switch.
- 3) Turn off the main power switch.
- 4) Unplug the power cable (for the outlet).

### 2.6.3 Installation procedure

iR5065 / iR 5055 / iR5075 / iR5075N / iR5065N / iR5055N



- When mounting the delivery Tray to the host machine, be sure to attach the rollers in the center of delivery roller.
- When mounting the delivery tray to the host machine, shift tray or finisher should not be mounted.

- 1) Open the front cover.
- 2) Turn the fixing/feeding assembly release lever [1] in the direction of the arrow to release the transfer/separation charging unit. Slide the fixing/feeding assembly [2] out.

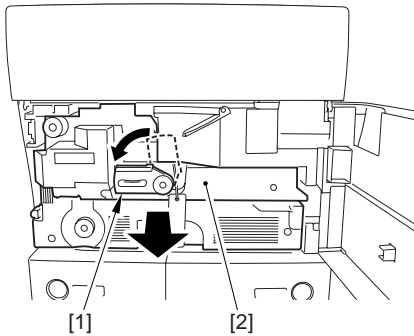

F-2-77

- 3) Remove the delivery roller guide [1].  
- 2 screws [2]

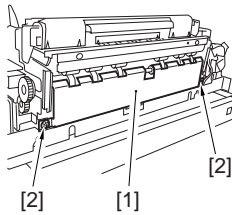

F-2-78

- 4) Attach the delivery roll.
  - Attach the delivery roll [1] to the position of the pin [3] found in the center of the delivery roller shaft [2].
  - Fit the protrusion [4] of one delivery roll to the mounting hole [5] of the other delivery roll.
  - Fit E-ring [6] to the groove on the delivery roller shaft to mount.

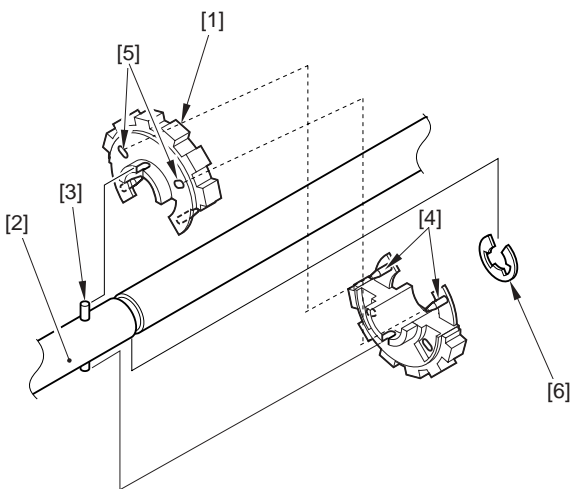

F-2-79



See the figure below to make sure the mounting direction of the delivery roller's protrusion [1].

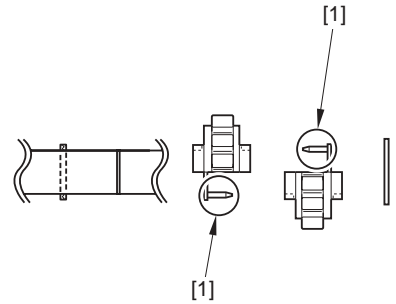

- 5) Mount the delivery roller guide.
- 6) Slide the fixing/feeding assembly in the machine and close the front cover.
- 7) Detach the left cover (upper) [1].  
- 2 screws [2]

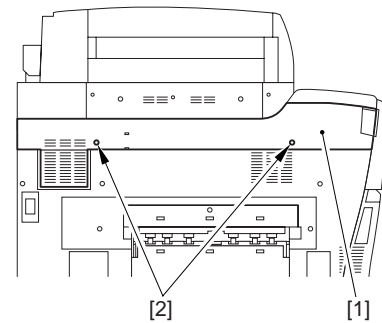

F-2-80

- 8) Attach the magnet plate [1] to the left cover (upper) and bend the claws [2] at the both ends in the direction of the arrow.

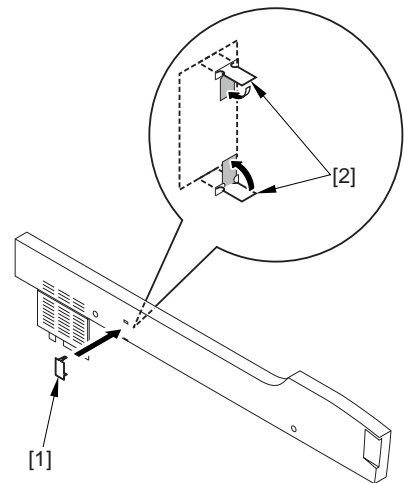

F-2-81

- 9) Attach the left cover (upper).
- 10) Fit the protruding parts [1] at the delivery tray end to the mounting holes [2] on the host machine.

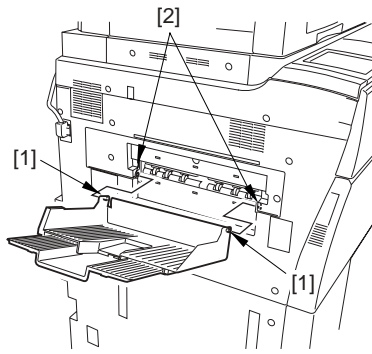

F-2-82

1) Attach the delivery tray bar [1].

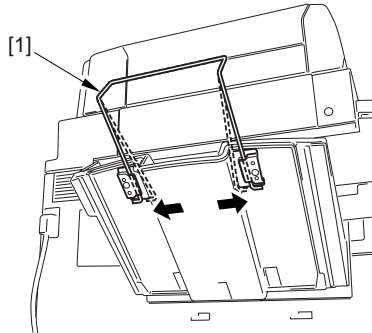

F-2-83

<Card Reader Attachment-C2>

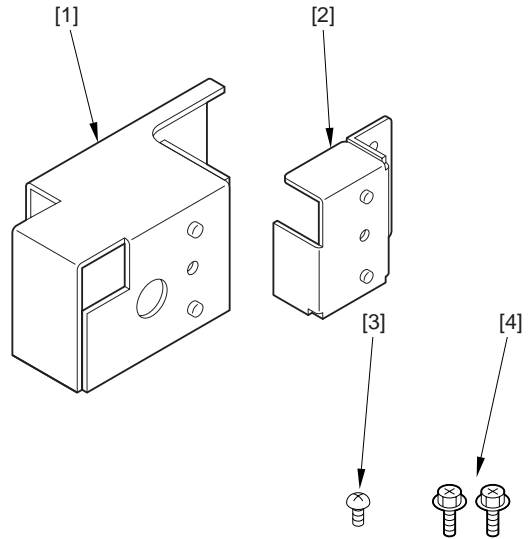

F-2-85

- |     |                                      |      |
|-----|--------------------------------------|------|
| [1] | Card reader attachment plate         | 1pc. |
| [2] | Joint plate                          | 1pc. |
| [3] | Screw<br>(small panhead screw; M4X6) | 1pc. |
| [4] | Screw (RS tightening; M4X10)         | 2pc. |

2.7 Installing the Card Reader

2.7.1 Notice At Installation

iR5065 / iR 5055 / iR5075 / iR5075N / iR5065N / iR5055N

**!** Installation of this equipment needs the card reader attachment kit C2.

2.7.2 Confirming the contents

iR5065 / iR 5055 / iR5075 / iR5075N / iR5065N / iR5055N

<Card Reader-C1>

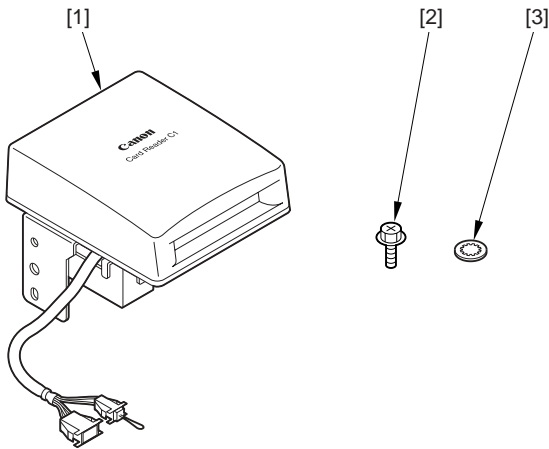

F-2-84

- |     |                              |      |
|-----|------------------------------|------|
| [1] | Card reader                  | 1pc. |
| [2] | Screw (RS tightening; M4X10) | 1pc. |
| [3] | Toothed washer               | 1pc. |

2.7.3 Power off of the host machine

iR5065 / iR 5055 / iR5075 / iR5075N / iR5065N / iR5055N

**!** **How to turn off the main power**  
When turn off the main power, implement the following steps to protect the hard disk of this product.

- 1) Push the control panel power switch for 3 sec or more.
- 2) Operate the touch panel following the instruction on the screen of shutdown sequence in order to be ready to turn off the main power switch.
- 3) Turn off the main power switch.
- 4) Pull out the power cable (for the outlet).

2.7.4 Installation procedure

iR5065 / iR 5055 / iR5075 / iR5075N / iR5065N / iR5055N

- 1) Open the toner replacement cover.
- 2) Detach the Right cover (upper)[1].  
- Screw [2] 2pc.

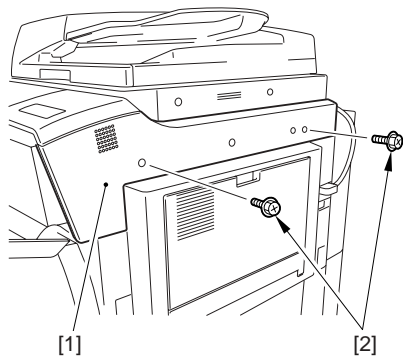

F-2-86

- 3) Attach the card reader attachment plate [1].  
- Screw (RS tightening; M4X10) [2] 2pc.

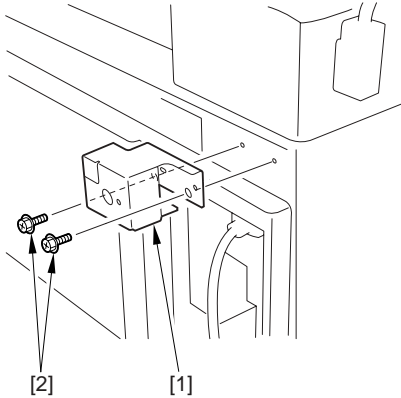

F-2-87

- 4) Attach the card reader to the joint plate [1] with 1 each of the toothed washer of the card reader and the screw (RS tightening; M4X10) [2].

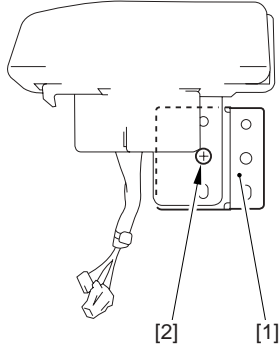

F-2-88

- 5) Put the harness [1] of the card reader through the hole [2] of the card reader attachment plate.

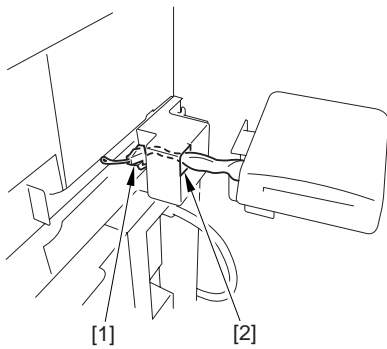

F-2-89

- 6) Attach the card reader [1].  
- Screw (small panhead screw; M4X6) [2] 1pc.

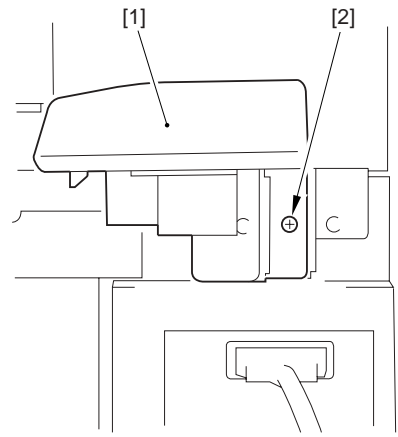

F-2-90

- 7) Get the cable [1] out from the side of the host machine.

**⚠**  
If the cable is difficult to remove, drivers etc. will help make the operation easier.

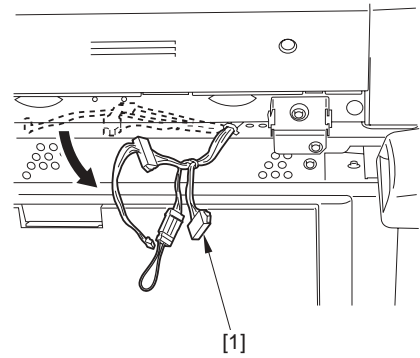

F-2-91

- 8) Connect the card reader harness with the connector [1].

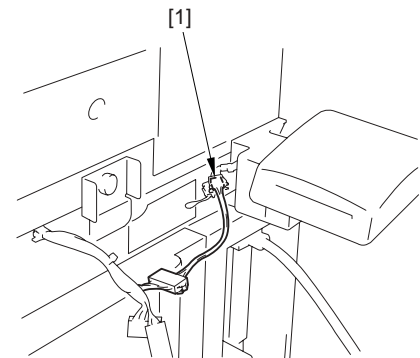

F-2-92

- 9) Put the cable [1] of the card reader through the 2 clamps [2].

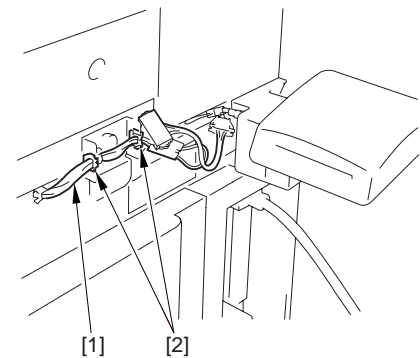

F-2-93

10) Cut the area [1] of the right cover (upper) with a wire cutter etc.

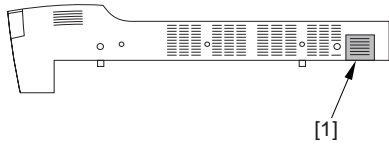

F-2-94

- 11) Attach the right cover (upper) detached in the step 2).
- 12) Close the toner replacement cover.
- 13) Insert the power cable (for the plug).
- 14) Turn on the main power switch, and then check the display demanding setting of the control card.
- 15) Input the card number (1 to 2001) to be used in the service mode (COPIER > FUNCTION > INSTALL > CARD).
  - Input the smallest card number for the user to use.
  - Up to 1,000 cards having been input are available.
- 16) Operate the touch panel following the instruction on the screen of shutdown sequence in order to turn off the main power switch.
- 17) Turn on the main power switch.
- 18) Insert the control card and check the status where copy is possible.

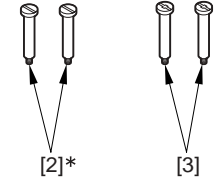
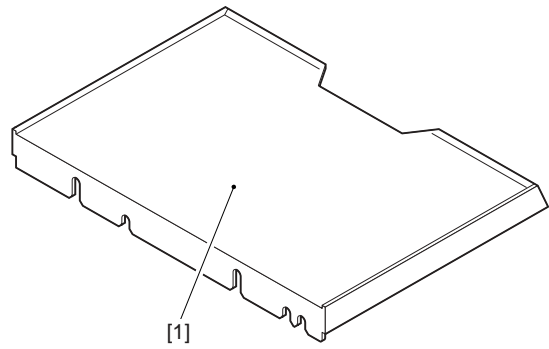

F-2-95

**2.7.5 Installing for imageWARE Accounting Manager**

iR5065 / iR 5055 / iR5075 / iR5075N / iR5065N / iR5055N

- 1) Check to see that 'ID00000001 to ID00001000' has been created in [System Settings] > [Dep ID Mangement] > [Registor Dept.ID/Password] > [Page Totals]. (In the case that '1' has been input as the first number by the service mode; COPIER > FUNCTION > INSTALL > CARD)
- 2) Press the reset key to escape the user mode screen.
- 3) Select [System Settings] > [Network Settings] > [TCP/IP Settings] > [IP Address Settings], and then make the setting of [IP Address], [Gateway Address], [Subnet Mask] according to the user environment
- 4) Press the reset key to escape the user mode screen.
- 5) Operate the touch panel following the instruction on the screen of shutdown sequence in order to turn off the main power switch.
- 6) Turn on the main power switch.
- 7)

[1]	Document Tray	1 pc.
[2]*	Stepped Screw (M4X31)	2 pc.
[3]	Stepped Screw (M4X33)	2 pc.

\* Not used with this host machine.

**2.8.2 Installation Procedure**

iR5065 / iR 5055 / iR5075 / iR5075N / iR5065N / iR5055N

1) Tighten the 2 stepped screws (M4X33) [1] to the upper cover (right).

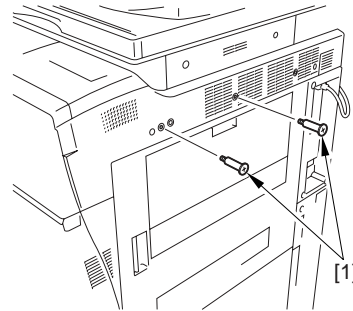

F-2-96

2) Hook the document tray [1] to the stepped screws tightened in the step 1.

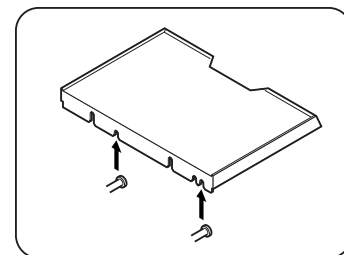

F-2-97

> [System Settings] > [System Maneger Settings] is selected and [System Manager ID] and [System Password] are registered, 'Registration of card to the device' is impossible to execute in the setting of iWAM.

- 8) Press the reset key to escape the user mode screen.
- 9) Turn off the power according to the shutdown sequence.

**2.8 Installing the Original Holder**

**2.8.1 Checking Contents**

iR5065 / iR 5055 / iR5075 / iR5075N / iR5065N / iR5055N

<Document Tray-K1>

**!**  
If it is hard to hook the document tray, loosen the 2 stepped screws and hook it once again.

**2.8.3 Checking Contents**

iR5065 / iR 5055 / iR5075 / iR5075N / iR5065N / iR5055N

<Document Tray-M1>

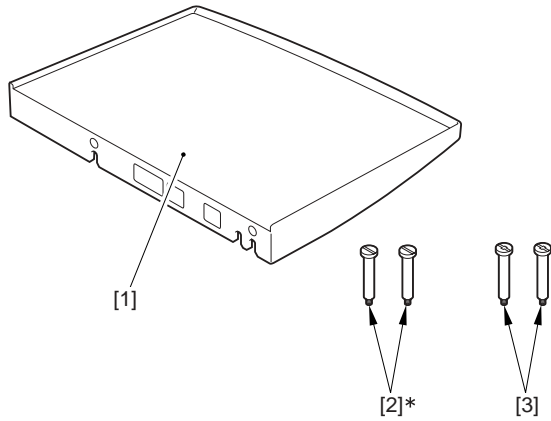

F-2-98

[1]	Document Tray	1 pc.
[2]*	Stepped Screw (M4X31)	2 pc.
[3]	Stepped Screw (M4X33)	2 pc.

\* [2] is not included in the product Code: 1386B001AA. Not used with this equipment.

**MEMO:**  
For the 120V model, use it as standard.

**2.8.4 Installation Procedure**

iR5065 / iR 5055 / iR5075 / iR5075N / iR5065N / iR5055N

1) Tighten the 2 stepped screws (M4X33) [1] to the upper cover (right).

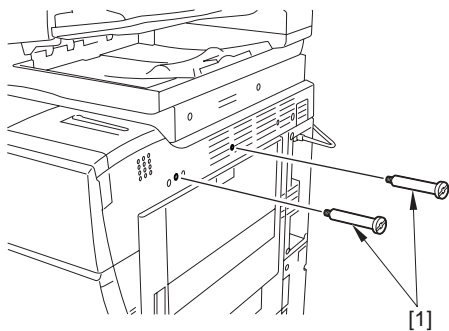

F-2-99

2) Hook the document tray [1] to the stepped screws tightened in the step 1.

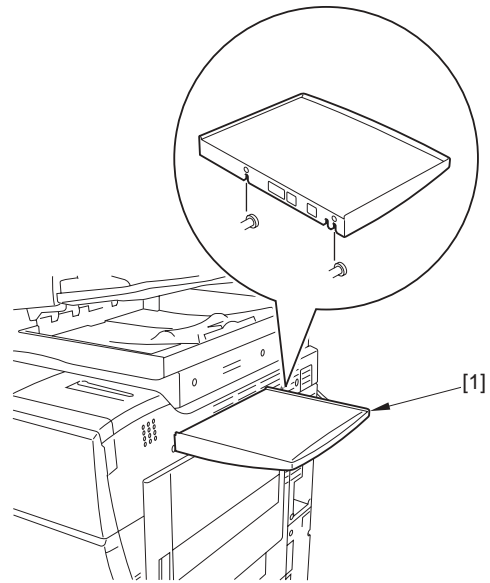

F-2-100

**!**  
If it is hard to hook the document tray, loosen the 2 stepped screws and hook it once again.

**2.9 Installing the Reader Heater**

**2.9.1 Checking the Contents**

iR5065 / iR 5055 / iR5075 / iR5075N / iR5065N / iR5055N

<Reader Heater Kit>

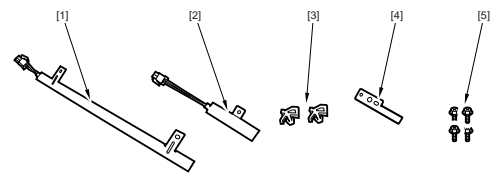

F-2-101  
T-2-6

[1]	Mirror Heater	FK2-0229	1pc
[2]	Lens Heater	FK2-0228	1pc
[3]	Cable Clamp	WT2-0507	2pc
[4]	Heater Harness Retainer	FC5-2945	1pc
[5]	Screw (RS tightening: M4X8)	XB3-6400	4pc

**2.9.2 Power off of the host machine**

iR5065 / iR 5055 / iR5075 / iR5075N / iR5065N / iR5055N

**⚠ How to turn off the main power**

When turn off the main power, implement the following steps to protect the hard disk of this product.

- 1) Push the control panel power switch for 3 sec or more.
- 2) Operate the touch panel following the instruction on the screen of shutdown sequence in order to be ready to turn off the main power switch.
- 3) Turn off the main power switch.
- 4) Pull out the power cable (for the outlet).

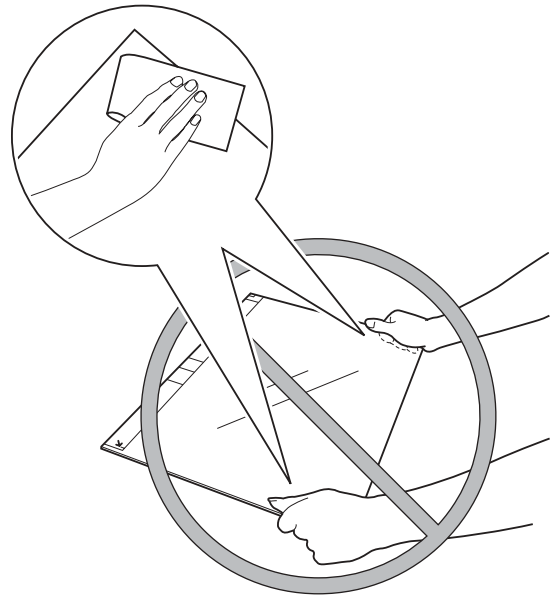

F-2-103

- 4) Hold the tab (the bend) [A] of the mirror stay to move the No. 1 mirror base [1] to the right until it stops.

**2.9.3 Installation Procedure**

iR5065 / iR 5055 / iR5075 / iR5075N / iR5065N / iR5055N

- 1) Open the DADF.
- 2) Remove the glass retainer [1].  
- Remove the 2 screws [2]
- 3) Remove the copyboard glass [3]

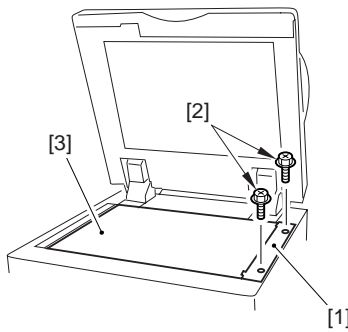

F-2-102

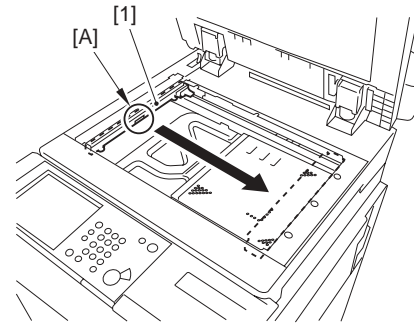

F-2-104

- 5) Insert the front side of the mirror heater [1] under the cable guide [2] and connect the connector [3], and then tighten with the 2 screws (RS tightening; M4X8) [4].



When removing the copyboard glass, be sure not to get your fingers touched with the glass surface or the backside of the white plate.  
In case the glass is soiled, clean it with lint-free paper.

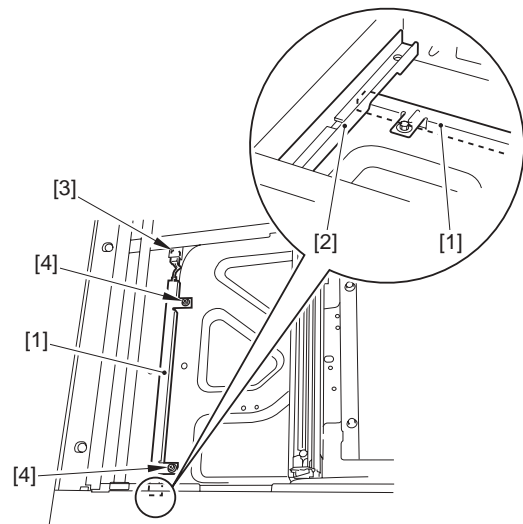

F-2-105

- 6) Attach the heater harness retainer [1].  
- 1 screw (RS tightening; M4X8) [2]



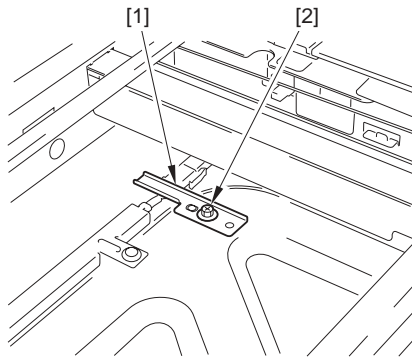

F-2-106

7) Hold the tab (the bend) [A] of the mirror stay to move the No. 1 mirror base [1] to the left until it stops.

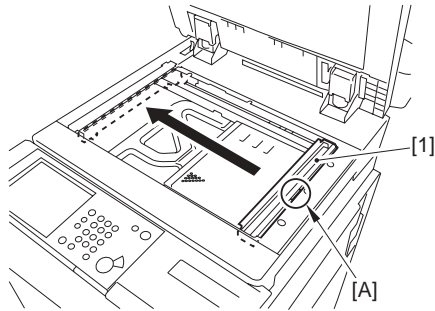

F-2-107

8) Insert the cable clamp [1] to the hole [2] of the frame.

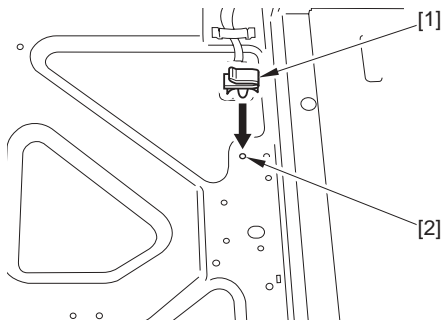

F-2-108

9) Attach the lens heater [1]  
 - 1 connector [2]  
 - 1 cable clamp [3]  
 - 1 screw (RS tightening; M4X8) [4]

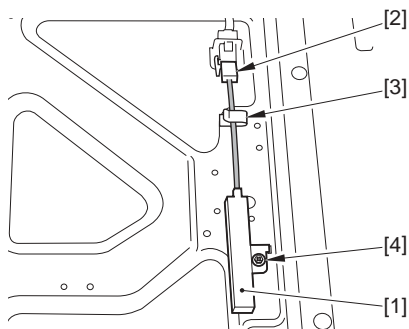

F-2-109



Tighten the screw [3] while pushing on the lens heater [1] in the direction of the emboss [2]. Be sure that the heater's claw [4] must not be disengaged when performing this operation. Also check that the bottom of the heater must not be off from the board.

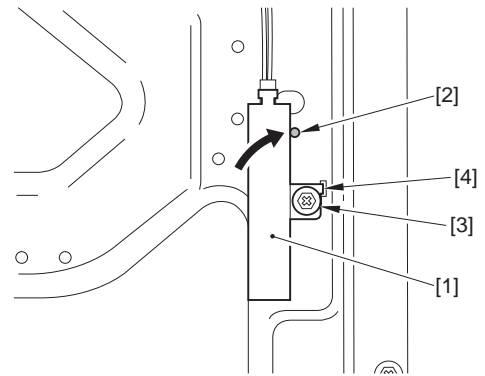

F-2-110

10) In case that the cable [1] is loose, insert the cable clamp [2] to the frame's hole to fix the cable in place.

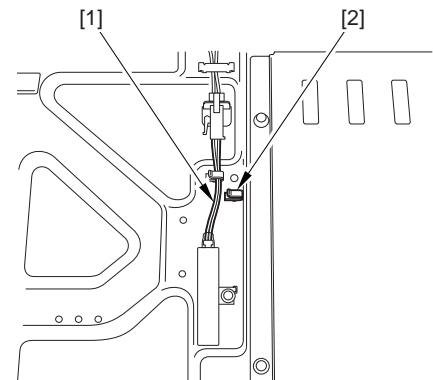

F-2-111

11) By reversing the steps used to remove, attach the copyboard glass and the glass retainer.  
 12) Close the DADF.  
 13) Shift the cassette heater switch [1] and the environment switch [2] to the on position.

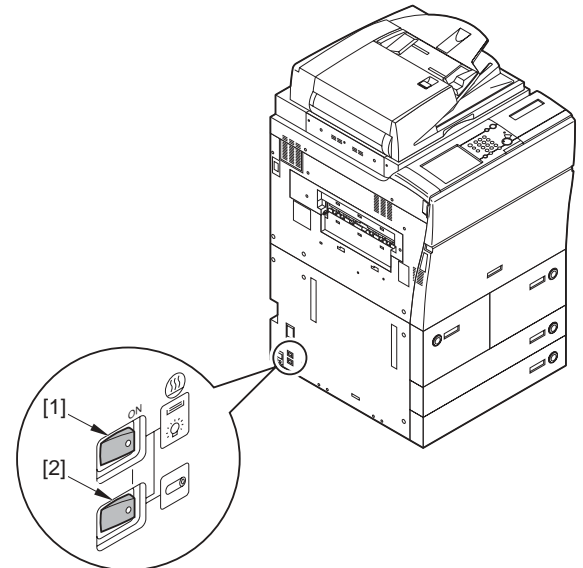

F-2-112

## 2.10 Installing the Cassette Heater

### 2.10.1 Checking Components

iR5065 / iR 5055 / iR5075 / iR5075N / iR5065N / iR5055N

<Cassette Heater>

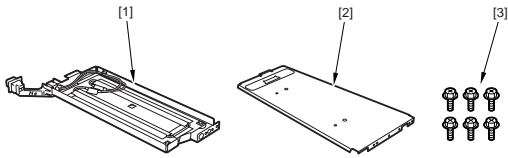

F-2-113

[1]	heater unit	FM2-4182-000	1pc.
[2]	cassette stay	FL2-3994-000	1pc.
[3]	screw (M4X6)	XB1-2400-609	6pc.

**2.10.2 Power off of the host machine**

iR5065 / iR 5055 / iR5075 / iR5075N / iR5065N / iR5055N

**⚠ How to turn off the main power**

When turn off the main power, implement the following steps to protect the hard disk of this product.

- 1) Push the control panel power switch for 3 sec or more.
- 2) Operate the touch panel following the instruction on the screen of shutdown sequence in order to be ready to turn off the main power switch.
- 3) Turn off the main power switch.
- 4) Pull out the power cable (for the outlet).

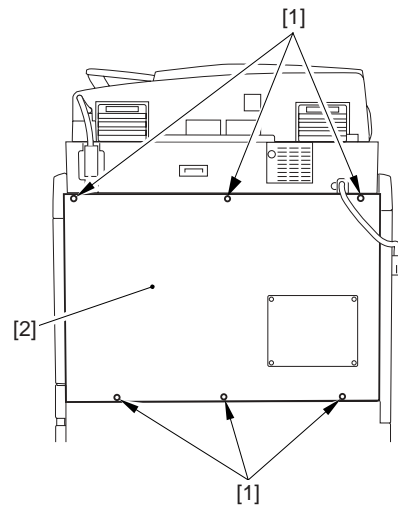

F-2-115

- 3) Detach the lower rear cover [1].  
- 6 screws [2]

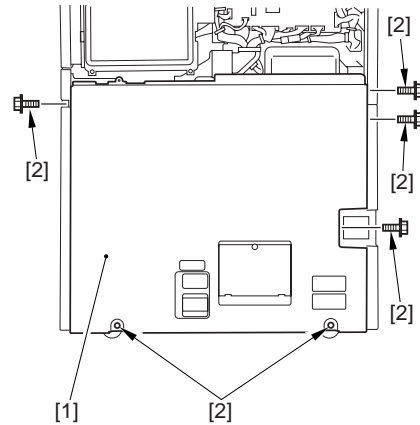

F-2-116

- 4) Remove the heat exhaust fan (filter) [1].  
- 3 screws [2]  
- 1 connector [3]

**2.10.3 Installation Procedure of the Cassette Heater**

iR5065 / iR 5055 / iR5075 / iR5075N / iR5065N / iR5055N

**⚠**  
Be sure to disconnect the power outlet.

- 1) Open the wire saddle [1] to disengage the reader communication cable [2].

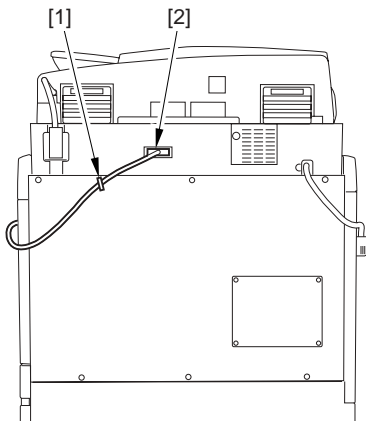

F-2-114

- 2) Detach the upper rear cover [1].  
- 6 screws [2]

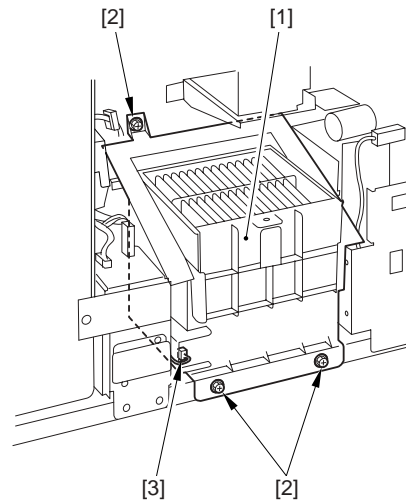

F-2-117

- 5) Hold down the release button [1] to slide Cassette 4 [2] out.

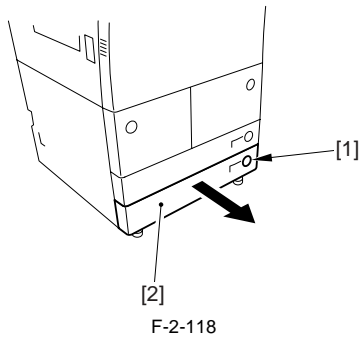

6) Lift the inner unit [1] in Cassette 4, and remove it.

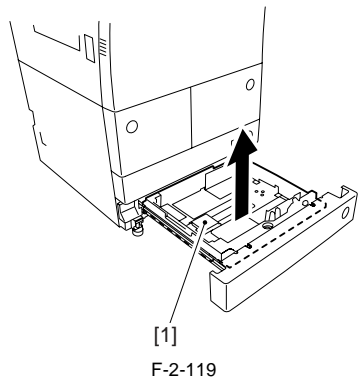

7) In the same way, remove the inner unit of Cassette 3.  
 8) Engage the claw [A] of the lead edge onto the long hole [B] of the host machine to attach the cassette stay [1].

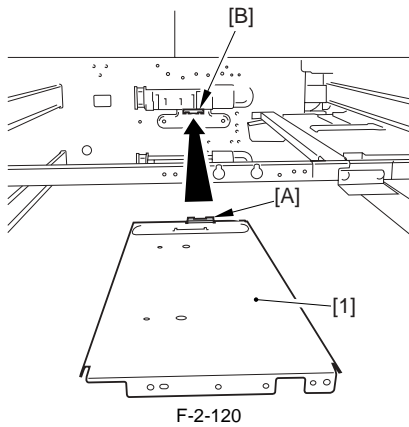

**⚠** Make sure from the rear side of the host machine that the claw [A] of the cassette stay is engaged appropriately.

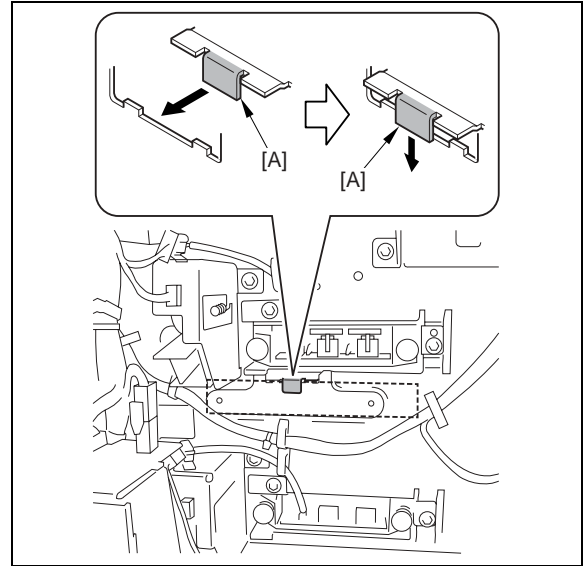

9) Secure the cassette stay [1] in place from the rear side of the host machine.  
 - 2 screws (M4X6) [2].

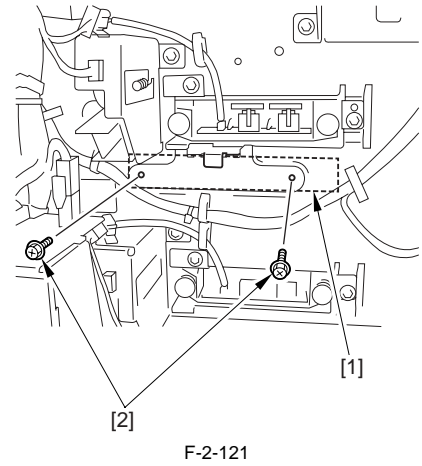

10) Secure the cassette stay [1] in place from the front side of the host machine.  
 - 2 screws [2] (M4X6)

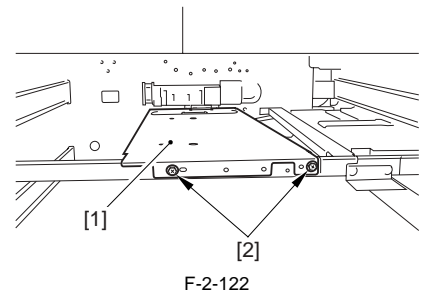

11) Put the cassette heater connector [1] through the long hole [A], while at the same time hook the metal plate [B] on the rear side of the cassette heater [2] onto the hole [C] of the cassette heater.

**⚠** Make sure that the heater cord guide [3] is fitted in place appropriately onto the long hole [A].

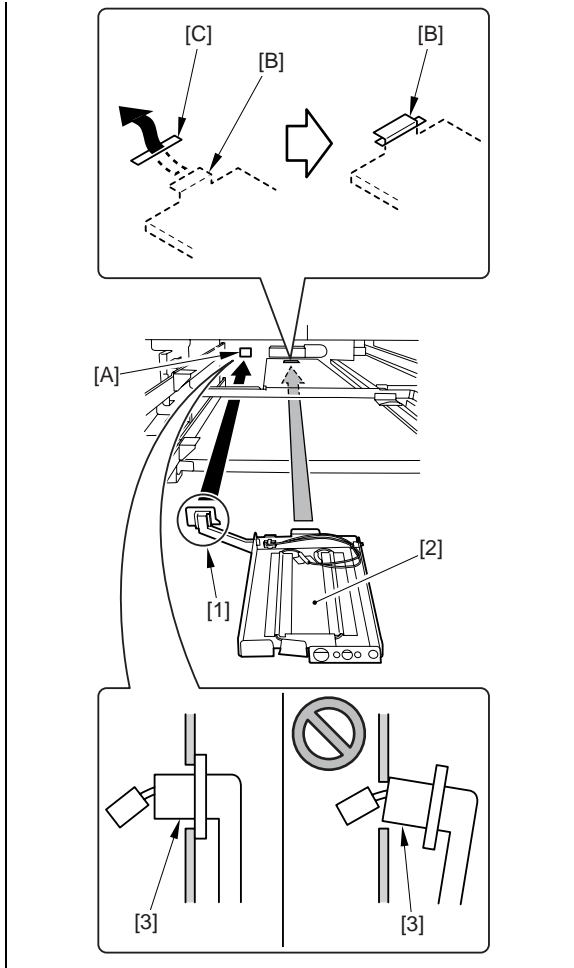

12) Lift the cassette heater [1] until it touches the host machine, and then secure it in place at the specified position with the 2 screws (M4X6) [2].

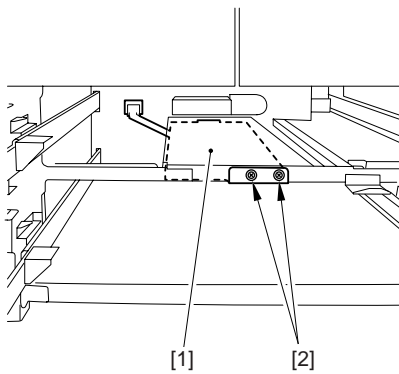

F-2-123

13) Connect the connector [1] on the host machine and the cassette heater connector [2].

No.	Part name	Part number	QTY	No.	Part name	Part number	QTY
[1]	Heater unit	FG6-9651	1pc.	[7]	Power supply label	FS6-8725	1pc.
[2]	AC input connector	FG6-1117	1pc.	[8]	Binding screw (M4 X 4)	XB1-2400-409	4pcs.
[3]	Relay harness unit	FG6-2957	1pc.	[9]	Wire saddle (Not used for this product)	WT2-5730	3pcs.
[4]	AC cable	FK2-4379	1pc.	[10]	Power supply code base	FC7-5473	1pc.
[5]	Screw (w/ washer)	XB2-7400-607	3pcs.	[11]	Screw (w/ flat spring)	XB2-8401-007	1pc.
[6]	Cable protection bush	WT2-5098	1pc.	[12]	Wire saddle	WT2-5738	1pc.

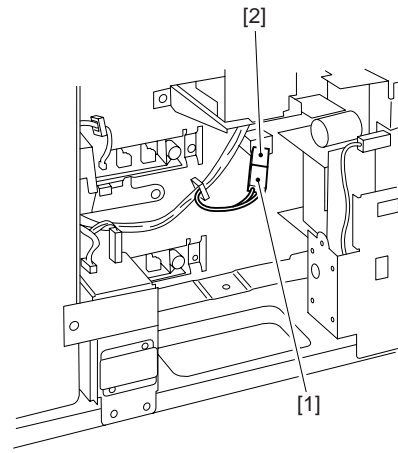

F-2-124

14) Attach the covers etc., by the reverse procedure to detach them.

- heat exhaust fan (filter)
- lower rear cover
- upper rear cover

15) Fit the inner units in each cassette in place, and then attach the cassettes onto the host machine.

16) Connect the power supply cable (for power outlet) of the host machine.

17) Turn on the main power switch.

## 2.11 Installing the Deck Heater

### 2.11.1 Checking the Parts to Install

iR5065 / iR 5055 / iR5075 / iR5075N / iR5065N / iR5055N

Every components of the cassette heater unit are supplied as service parts, so have the following parts on hand.

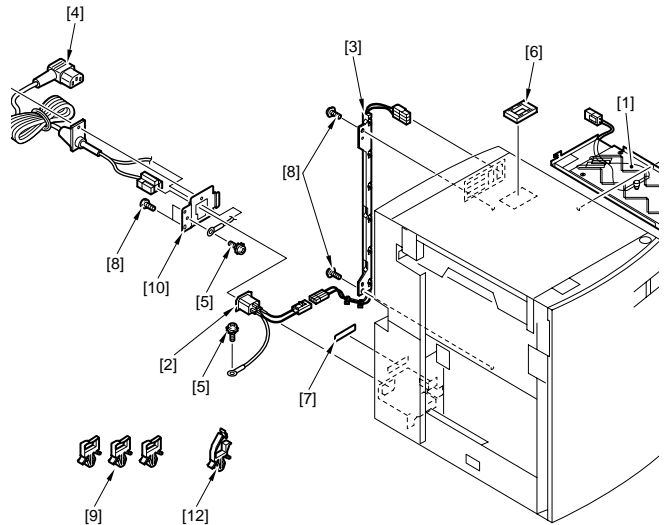

F-2-125

T-2-7

## 2.11.2 Turning Off the Host Machine

iR5065 / iR 5055 / iR5075 / iR5075N / iR5065N / iR5055N



Turning Off the Main Power of the Host Machine When turning off the main power, be sure to go through the following in strict sequence to protect the machine's hard disk:

- [1] Hold on the power switch on the control panel 3 sec or more.
- [2] Operate on the touch panel according to the shut-down sequence indicated so that the main power switch may be turned off.
- [3] Turn off the main power switch.
- [4] Disconnect the power cable (for the power outlet).

## 2.12 Installing the Deck Heater (Large Deck)

### 2.12.1 Checking the Parts to Install

iR5065 / iR 5055 / iR5075 / iR5075N / iR5065N / iR5055N

Every components of the cassette heater unit are supplied as service parts, so have the following parts on hand.

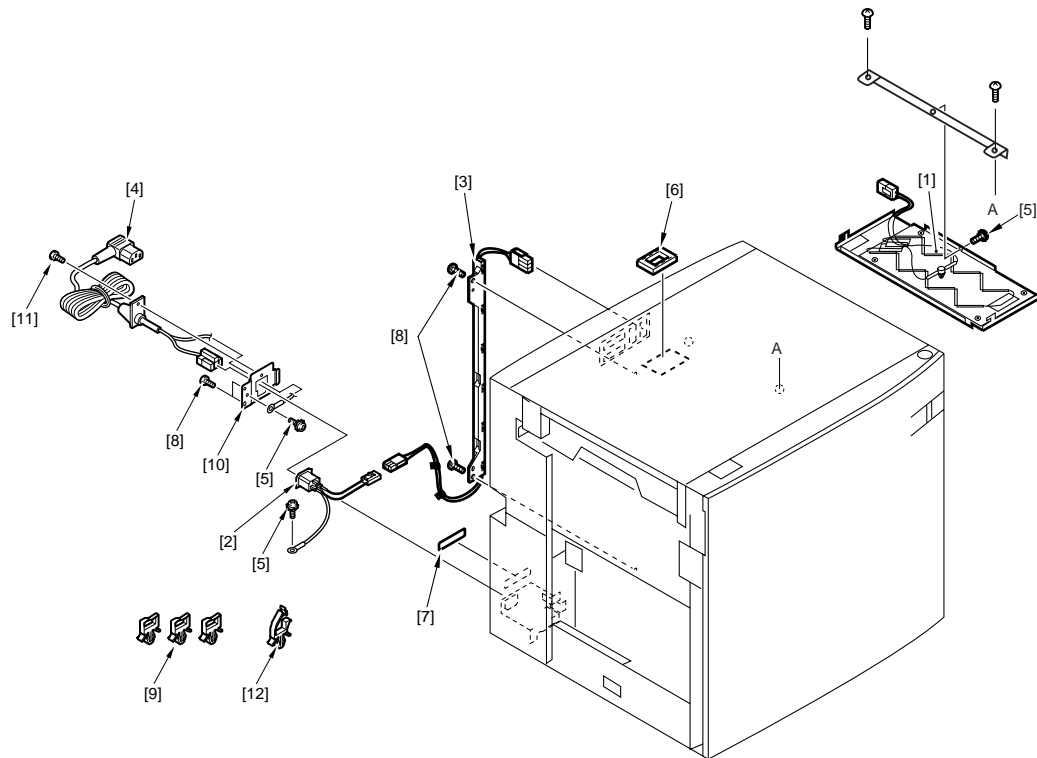

F-2-126  
T-2-8

No.	Part name	Part number	QTY	No.	Part name	Part number	QTY
[1]	Heater unit	FG6-9651	1pc.	[7]	Power supply label	FS6-8725	1pc.
[2]	AC input connector	FG6-1117	1pc.	[8]	Binding screw (M4 X 4)	XB1-2400-409	4pcs.
[3]	Relay harness unit	FG6-2957	1pc.	[9]	Wire saddle	WT2-5730	3pcs.
[4]	AC cable	FK2-4379	1pc.	[10]	Power supply code base	FC7-5473	1pc.
[5]	Screw (w/ washer)	XB2-7400-607	3pcs.	[11]	Screw (w/ flat spring)	XB2-8401-007	1pc.
[6]	Cable protection bush	WT2-5098	1pc.	[12]	Wire saddle	WT2-5738	1pc.

### 2.12.2 Turning Off the Host Machine

iR5065 / iR 5055 / iR5075 / iR5075N / iR5065N / iR5055N



Turning Off the Main Power of the Host Machine When turning off the main power, be sure to go through the following in strict sequence to protect the machine's hard disk:

- [1] Hold on the power switch on the control panel 3 sec or more.
- [2] Operate on the touch panel according to the shut-down sequence indicated so that the main power switch may be turned off.
- [3] Turn off the main power switch.
- [4] Disconnect the power cable (for the power outlet).

### 2.13 Installing the Voice Guidance Kit

#### 2.13.1 A point to keep in mind at installation

iR5065 / iR 5055 / iR5075 / iR5075N / iR5065N / iR5055N



- When installing the machine, see the Combination Table for Accessory Installation.
- In order to install this equipment, "Expansion Bus-D2" is required.

#### 2.13.2 Checking the Contents

iR5065 / iR 5055 / iR5075 / iR5075N / iR5065N / iR5055N

<Voice Guidance Kit-B1>

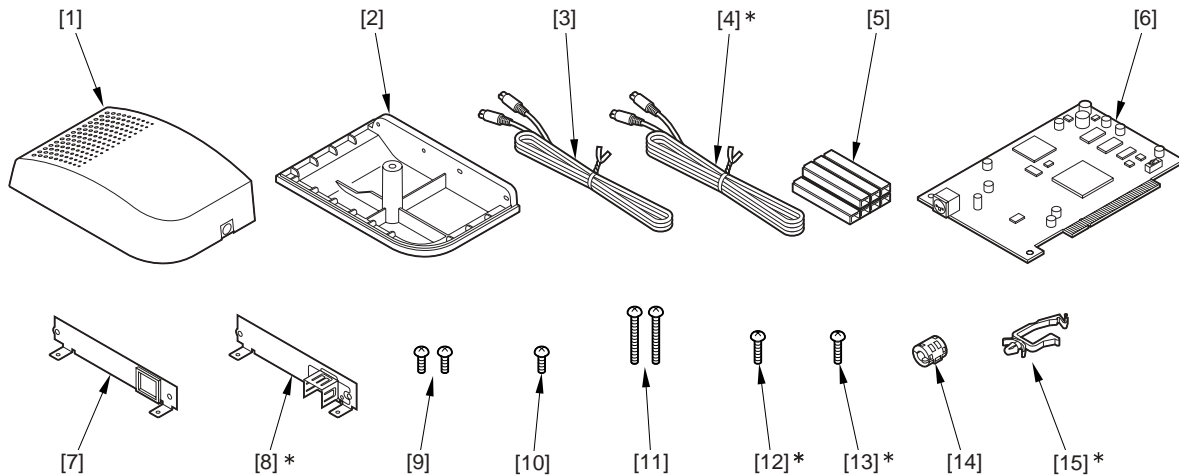

F-2-127

[1]	Speaker Unit (Upper)	1pc.	[2]	Speaker Unit (Lower)	1pc.
[3]	Cable (1300 mm)	1pc.	[4]*	Cable (1850 mm)	1pc.
[5]	Cord Guide	7pc.	[6]	Voice Board	1pc.
(this machine requires 6 cord guides)					
[7]	Voice Board instruction plate	1pc.	[8]*	Voice Board instruction plate	1pc.
[9]	Screw (binding; M3X6)	2pc.	[10]	Screw (binding; M4X6)	1pc.
[11]	Screw (binding; M4X40)	2pc.	[12]*	Screw (binding; M3X16)	1pc.
[13]*	Screw (binding; M4X16)	1pc.	[14]	Ferrite Core	1pc.
[15]*	Wire Saddle	1pc.			

\* Not used for this machine

Advice Book, CD.

- Voice Guidance Kit Users Guide
- Voice Guidance Kit Users Guide CD

### 2.13.3 Power off of the host machine

iR5065 / iR 5055 / iR5075 / iR5075N / iR5065N / iR5055N

**⚠ How to turn off the main power**  
 When turn off the main power, implement the following steps to protect the hard disk of this product.

- 1) Push the control panel power switch for 3 sec or more.
- 2) Operate the touch panel following the instruction on the screen of shutdown sequence in order to be ready to turn off the main power switch.
- 3) Turn off the main power switch.
- 4) Pull out the power cable (for the outlet).

### 2.13.4 Installation Procedure

iR5065 / iR 5055 / iR5075 / iR5075N / iR5065N / iR5055N

- 1) Open the cable clamp [1], and disconnect the reader communications cable [2].

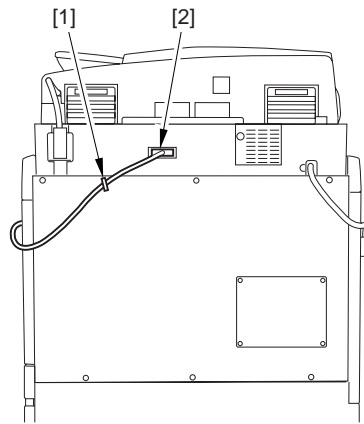

F-2-128

- 2) Detach the upper rear cover [1].  
 - 6 screws [2]

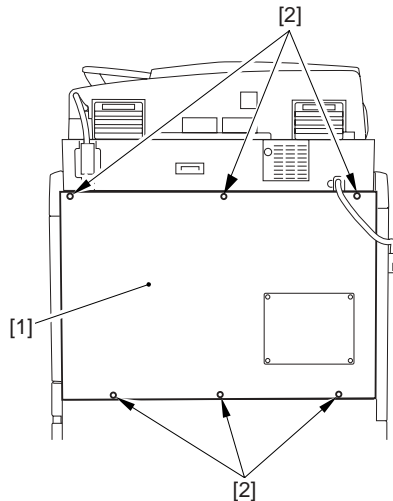

F-2-129

- 3) Detach the main controller box cover [1].  
 - 4 screws [2]

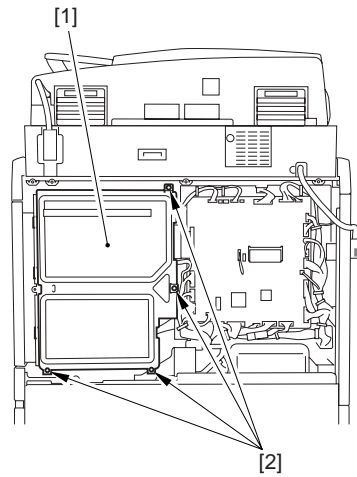

F-2-130

- 4) Remove the face cover plate [1]. (The removed plate is not used after this step.)  
 - 2 screws [2]

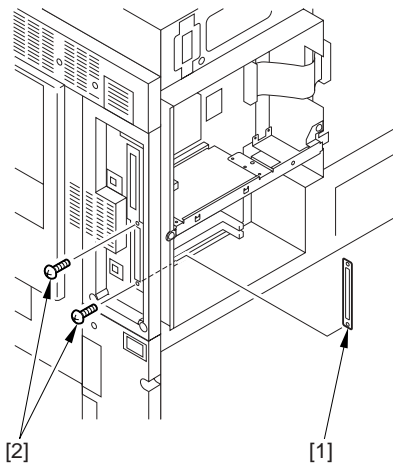

F-2-131

- 5) Attach the Voice Board instruction plate [2] to the voice board [1].  
 - 2 screws (binding; M3X6) [3]

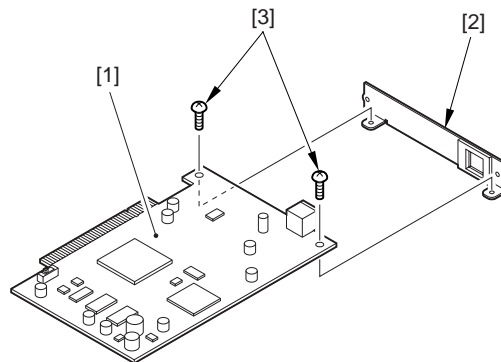

F-2-132



**Checking the Position of the Slide Switch (SW1) on the Voice Guidance Board**

The slide switch (SW1) on the Voice Guidance Board is provided as a means of switching frequencies (33 MHz/66 MHz) to suit the transfer speed of the PCI bus. It is important for the switch setting to suit the transfer speed so that the voice will be free of interruption. If you inadvertently moved the slide, be sure to put it back to its correct position. For the Board, the frequency must be set to 66 MHz.



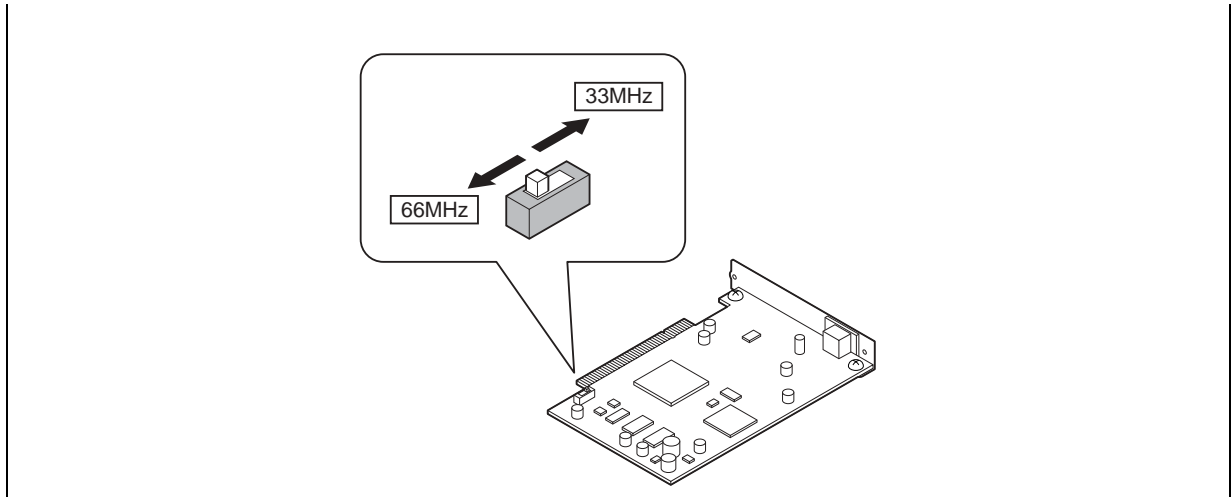

6) Mount the voice board [1] to the PCI Expansion Kit-D2 using the 2 screws [2] removed in step 4).

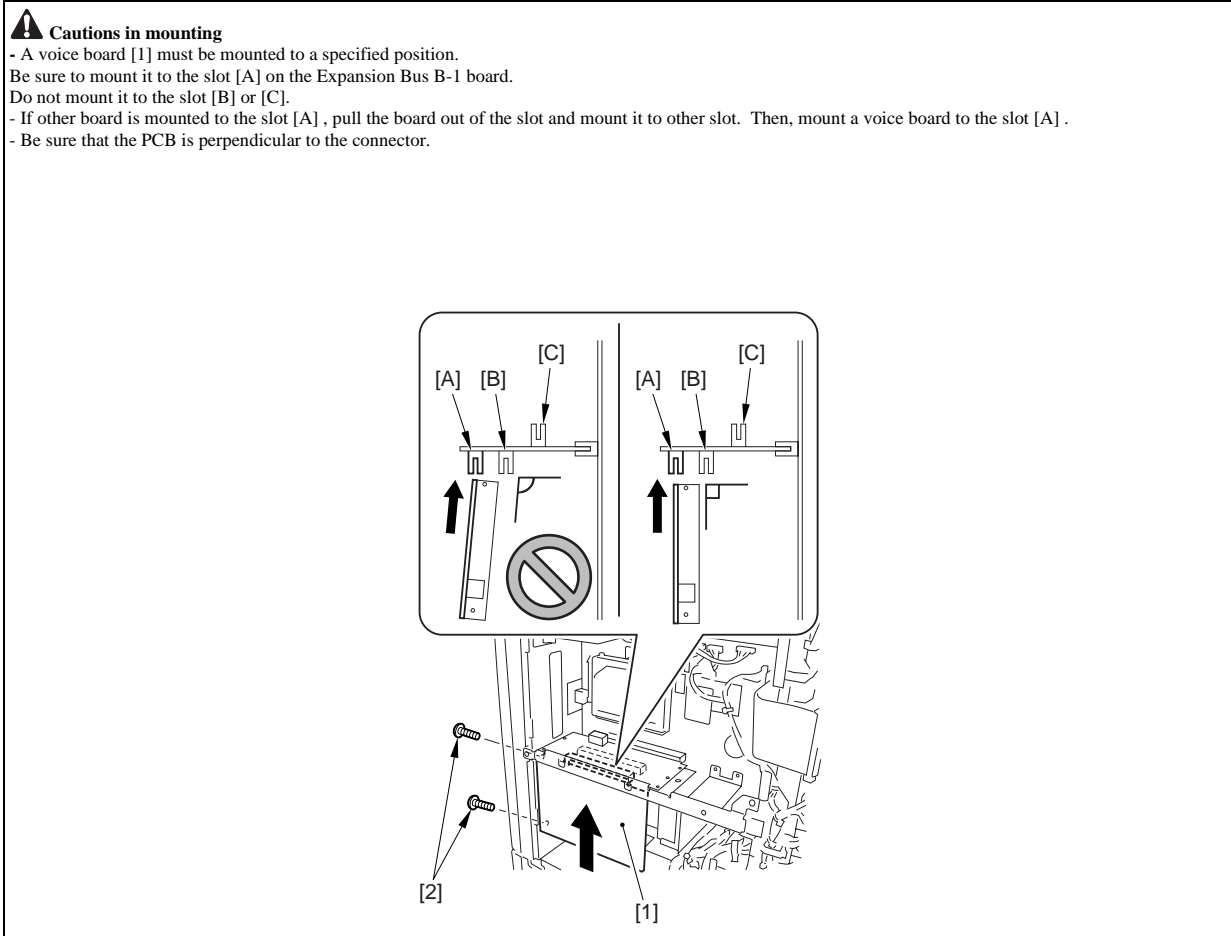

- 7) Attach the removed parts.
- Main controller box cover
  - Upper rear cover
- 8) Connect the reader communication cable.
- 9) Close the reader communication cable with the wire saddle.
- 10) Mount the speaker Unit (Lower) [1] to the upper right cover of the host machine.
- 2 screws (binding; M4X40) [2]

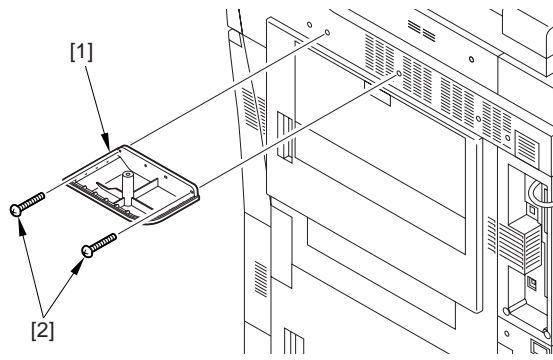

F-2-133

11) Mount the speaker unit (upper) [1] on the speaker unit (lower), fix them with a screw (binding; M4X6) [2] from beneath.

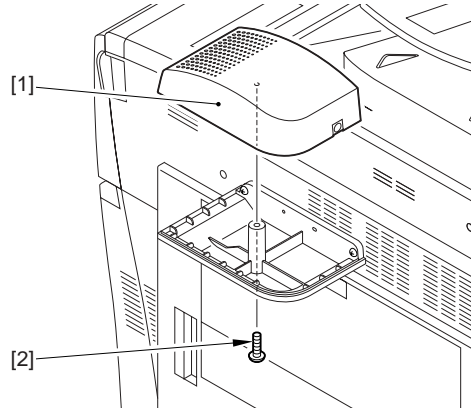

F-2-134

12) Take off the cover [1] from the code guide.

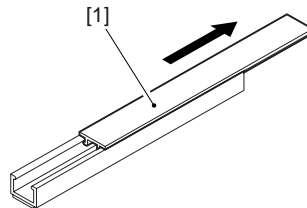

F-2-135

13) Peel off the released paper of the code guide [1] and affix it to the host machine as shown in the figure.

The right side --- 2 places

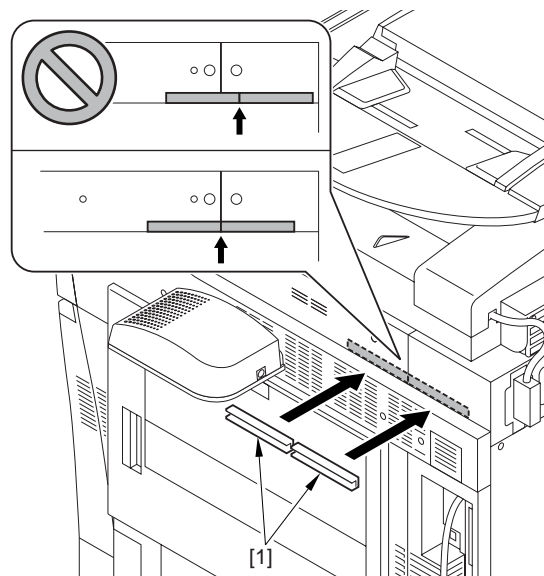

F-2-136

The rear -- 4 places

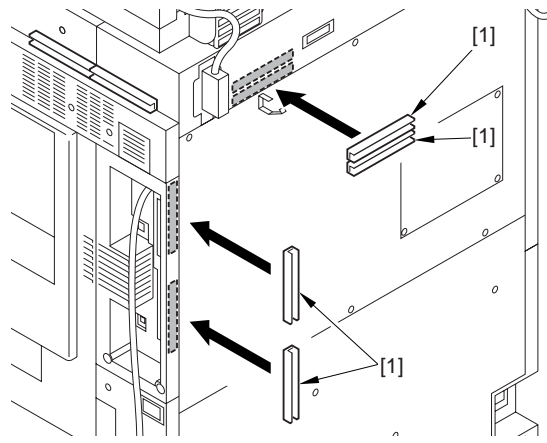

F-2-137

14) Connect the cable [2] into the speaker unit [1].

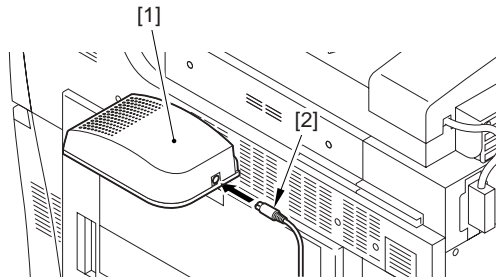

F-2-138

15) Run the cable [1] through the cable guide [2] and mount the cable guide cover [3].

**!** There should no excessive bending of the cable.

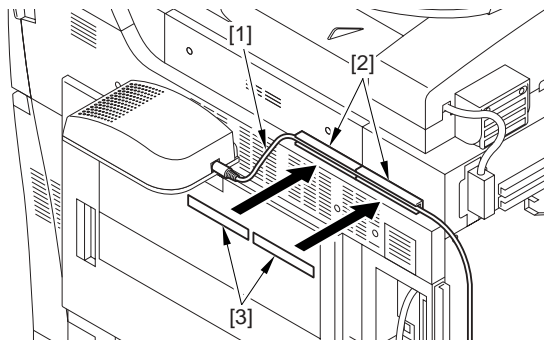

F-2-139

16) Attach the ferrite core [1] to the cable. Be sure that the length [2] is 50 mm or shorter.

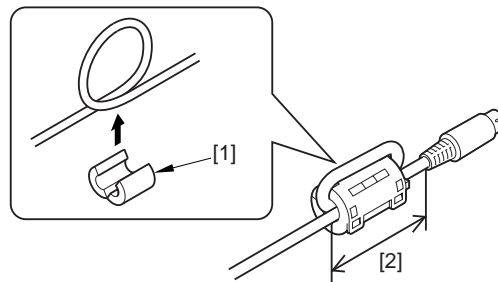

F-2-140

17) Connect the cable [1] to the terminal [2] of the voice board.

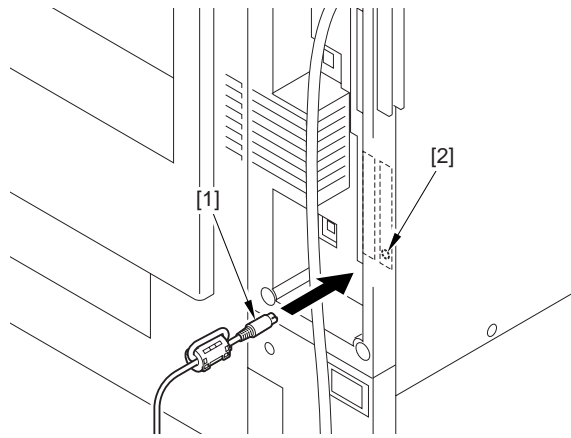

F-2-141

18) Run the cable [1] through the code guide [2] and mount the code guide cover [3].

 There should no excessive bending of the cable.

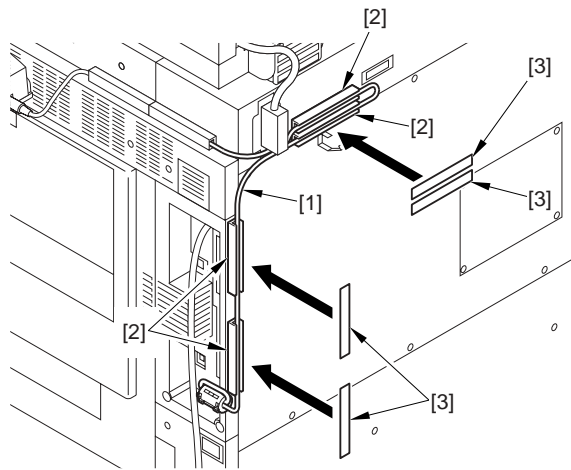

F-2-142

- 19) Connect the power cable to the outlet.
- 20) Turn ON the main power switch.
- 21) Check if the voice board is recognized.
  - Service mode
  - Select COPIER > DISPLAY > ACC-STS > PCI
  - If "Voice Board" is displayed, that means that the voice board is correctly recognized.

**2. Checking the Settings**

After turning on the power of host machine, check the following settings to use the Voice Guidance Kit.

- 1)  > [System Settings] > [Voice Navigation Management Settings] > [Use Voice Guide]
- 2) Check that it is set to ON.

**3. Operation Check**

<When Using the Voice Guidance>

- 1) Press the reset key for 3 sec or longer.
- 2) When the display of the number of copy is enclosed with red lines on the screen, "Voice Guidance" becomes enabled.

<When Stopping the Usage>

- 1) Press the reset key for 3 sec or longer.

## 2.14 Installing the Wireless Network Interface Adapter

### 2.14.1 Points to Note When Installing

iR5065 / iR 5055 / iR5075 / iR5075N / iR5065N / iR5055N



- After installing the "Expansion Bus-D2", install this equipment.
- After installing this equipment, cannot install "Voice Guidance Kit-B1".

### 2.14.2 Checking the Contents

iR5065 / iR 5055 / iR5075 / iR5075N / iR5065N / iR5055N

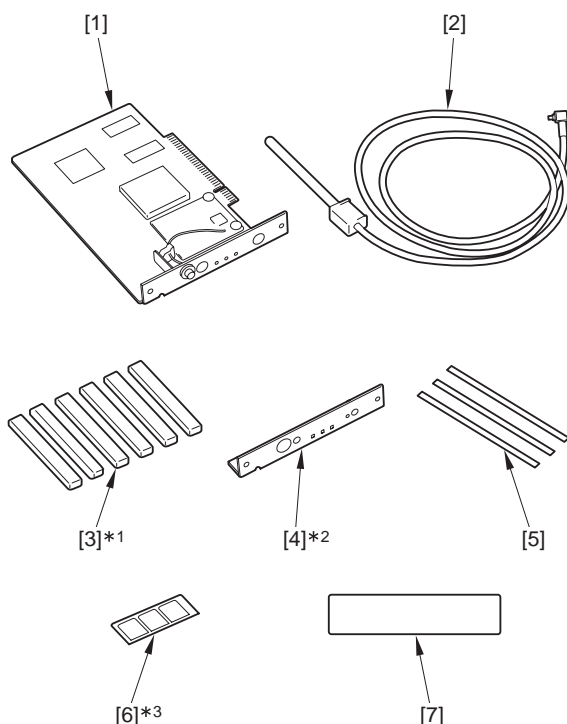

F-2-143

[1]	Wireless LAN board	1 pc
[2]	MFP antenna	1 pc
[3]*1	Cord guide	6 pc
[4]*2	PCB support plate (CL)	1 pc
[5]	Gasket	3 pc
[6]*3	Antenna affixing tape	1 sheet
[7]	Wireless LAN display label	1 pc

\*1; For this machine, use 5 pieces.

\*2; Not used with this machine.

\*3; Keep the remaining tape from the 3 sheets in a safe place for later use.

< CD/Guides >

- Wireless Network Interface Adapter NB-W1 Users Guide
- Wireless Network Interface Adapter NB-W1 Manual CD

### 2.14.3 Power off of the host machine

iR5065 / iR 5055 / iR5075 / iR5075N / iR5065N / iR5055N



#### How to turn off the main power

When turn off the main power, implement the following steps to protect the hard disk of this product.

- 1) Push the control panel power switch for 3 sec or more.
- 2) Operate the touch panel following the instruction on the screen of shutdown sequence in order to be ready to turn off the main power switch.
- 3) Turn off the main power switch.
- 4) Pull out the power plug.

### 2.14.4 Installation Procedure

iR5065 / iR 5055 / iR5075 / iR5075N / iR5065N / iR5055N

#### 1. Installation Procedure

- 1) Open the wire saddle [1] and disconnect the reader communication cable [2].

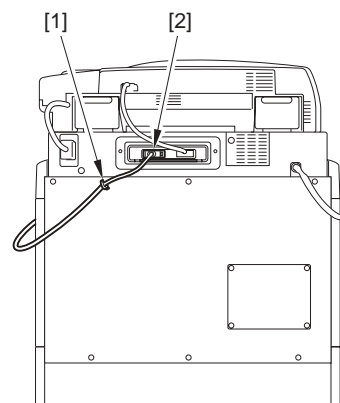

F-2-144

- 2) Detach the upper rear cover [1].  
- 6 screws [2]

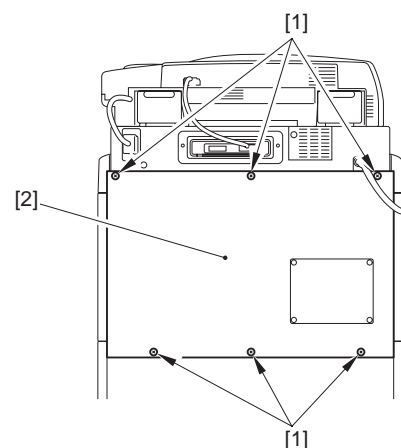

F-2-145

- 3) Detach the main controller box cover [1].  
- 4 screws [2]

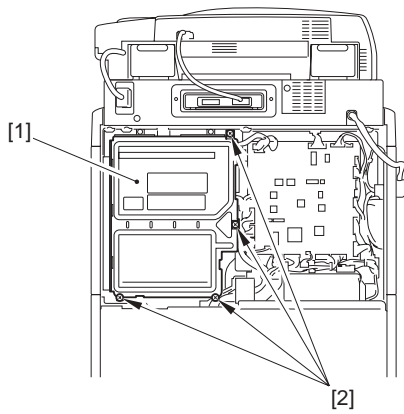

F-2-146

- 4) Remove the 2 face cover plates [1].  
- 4 screws [2]

**MEMO:**  
Of the detached 2 face cover plates, one at the wireless LAN board will not be used.

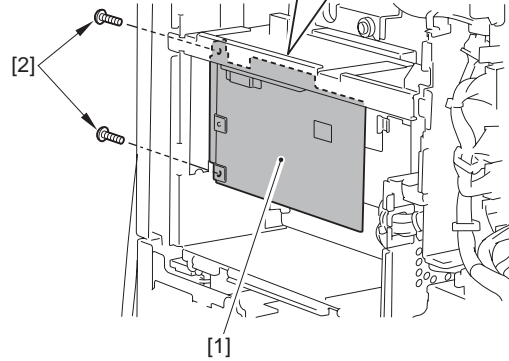
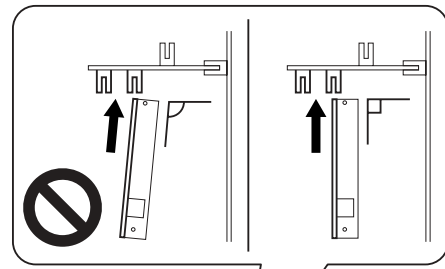

F-2-149

- 7) Attach the parts so far removed.  
- Face cover plate  
- Main controller box cover  
- Upper rear cover
- 8) Remove the antenna affixing tape [1] from the sheet and put it on the MFP antenna [2].

**MEMO:**  
Keep the 2 remaining tapes in the safe place for later use.

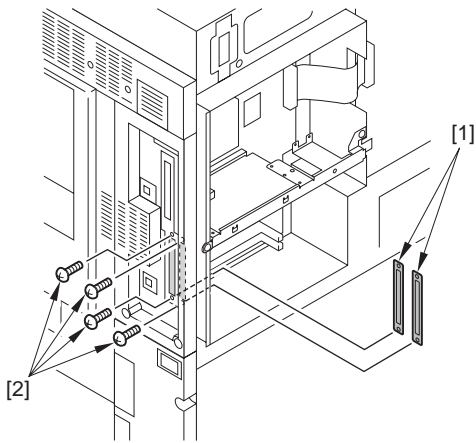

F-2-147

- 5) Put the 3 gaskets [1] on the indicated position inside the main controller box.

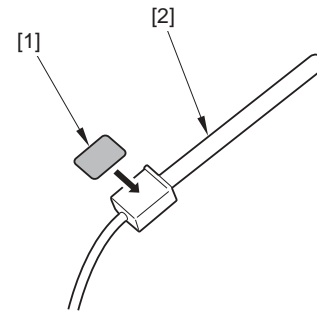

F-2-150

- 9) Put the MFP antenna [1] on the indicated position at the rear left side of the host machine.

**⚠**  
The following figure is a recommended position.  
Make sure not to put the position that disturbs the host machine operation or open/close.

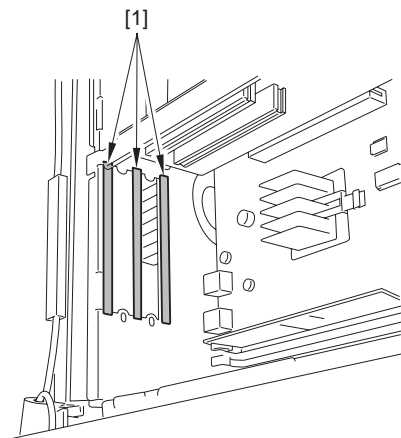

F-2-148

- 6) Attach the wireless LAN board [1] to the expansion bus.  
- 2 screws [2] (screws removed at step 4)

**⚠**  
Make sure that the board is in the upright position against the connector when attaching.

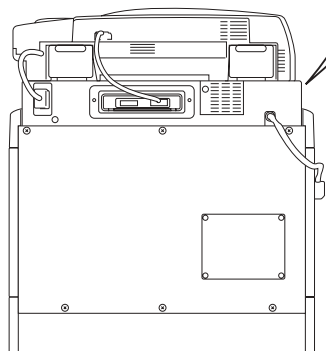
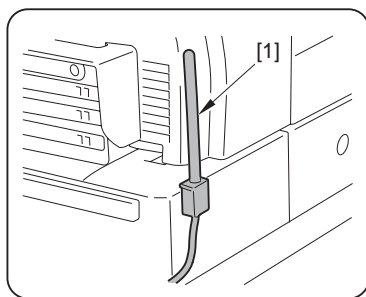

F-2-151

10) Detach the 5 covers of the cord guide [1].

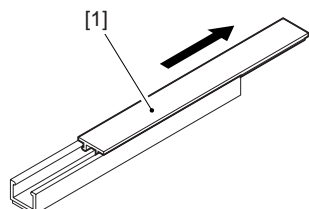

F-2-152

11) Remove the sheet of the 5 cord guides [1] and put them on the indicated position at the rear side of the host machine.

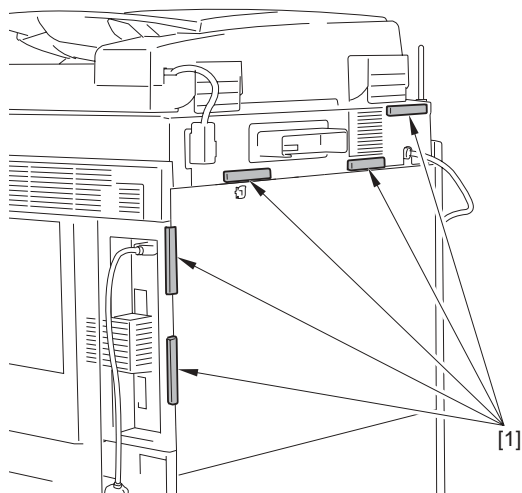

F-2-153

12) Put the MFP antenna cable [1] through the 5 cord guides [2] and attach the cord guide cover.



Make sure to route the cable without cable loosening.

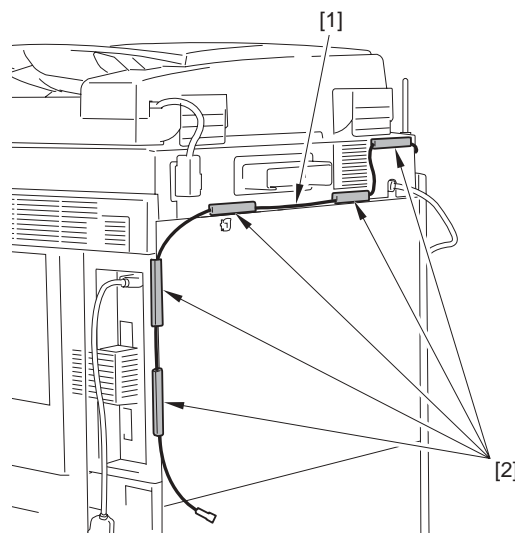

F-2-154

13) Connect the MFP antenna cable [1] with the wireless LAN board terminal [2].

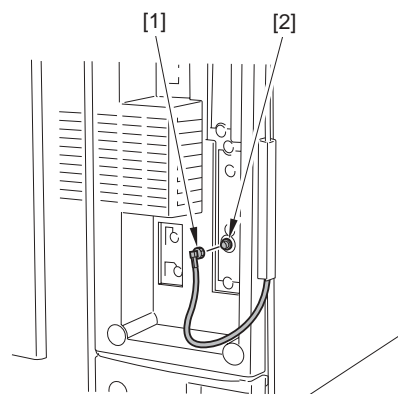

F-2-155

- 14) Insert the reader communication cable and secure it with the wire saddle.
- 15) Put the power plug into the outlet.
- 16) Turn ON the main power switch.
- 17) Check if the wireless LAN board is recognized.  
Enter service mode.  
Select COPIER > DISPLAY > ACC-STS > PCI.  
If "Wireless LAN Board" is displayed, that means that the wireless LAN board is correctly recognized.

## 2. Output the user data list

Output the user data list in order to check that the wireless LAN has been recognised.

- 1) Select: [Additional Functions] > [Report Settings] > [Extension Card] in the Print List > [User Data List].
- 2) After a message is displayed, select 'Yes' to output the user data list.

### 2.14.5 Affixing the Label

iR5065 / iR 5055 / iR5075 / iR5075N / iR5065N / iR5055N

- 1) Affix the wireless LAN display label [2] on the indicated position [1] of the rear upper cover.

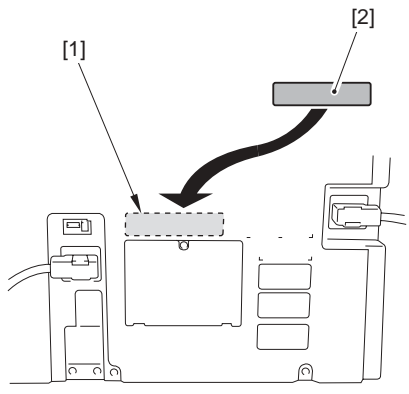

F-2-156



---

## Chapter 3 Basic Operation

---



---

# Contents

3.1 Construction .....	3-1
3.1.1 Functional Construction.....	3-1
3.1.2 Wiring Diagram of the Major PCBs .....	3-1
3.1.3 Controlling the Main Motor (M2).....	3-2
3.2 Basic Sequence .....	3-3
3.2.1 Basic Sequence of Operation (at power-on; 30-sec start-up mode).....	3-3
3.2.2 Basic Sequence of Operation (at power-on; low-temperature start-up mode).....	3-3
3.2.3 Basic Sequence of Operation (at power-on; high-humidity start-up mode) .....	3-4
3.2.4 Basic Sequence of Operation (at time of copying/printing) .....	3-5



### 3.1 Construction

#### 3.1.1 Functional Construction

iR5065 / iR 5055 / iR5075 / iR5075N / iR5065N / iR5055N

The machine may be divided into the following seven functional blocks:

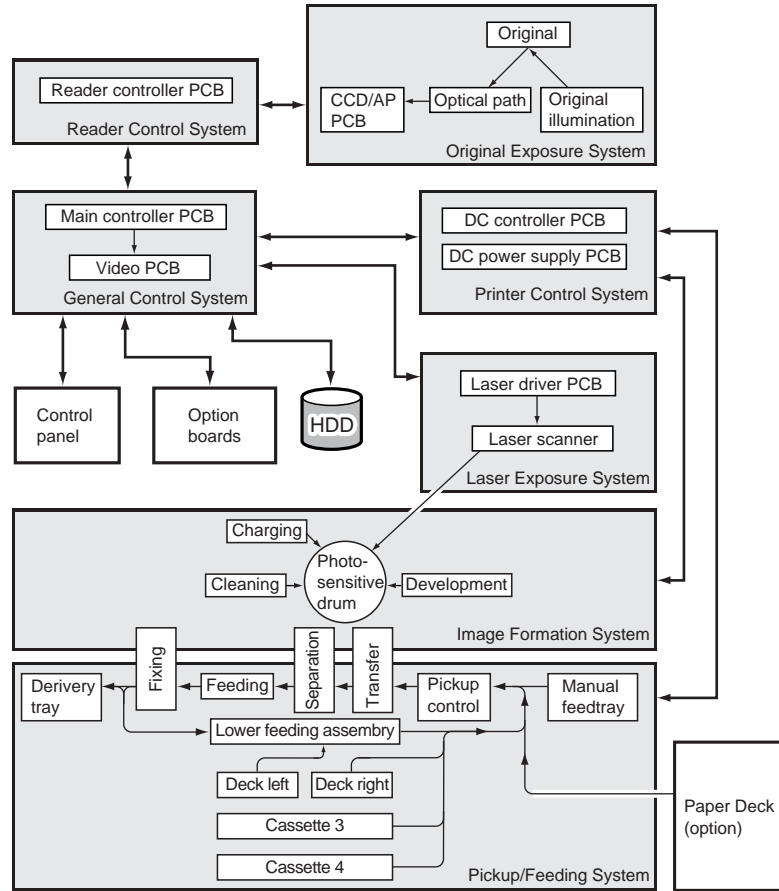

F-3-1

#### 3.1.2 Wiring Diagram of the Major PCBs

iR5065 / iR 5055 / iR5075 / iR5075N / iR5065N / iR5055N

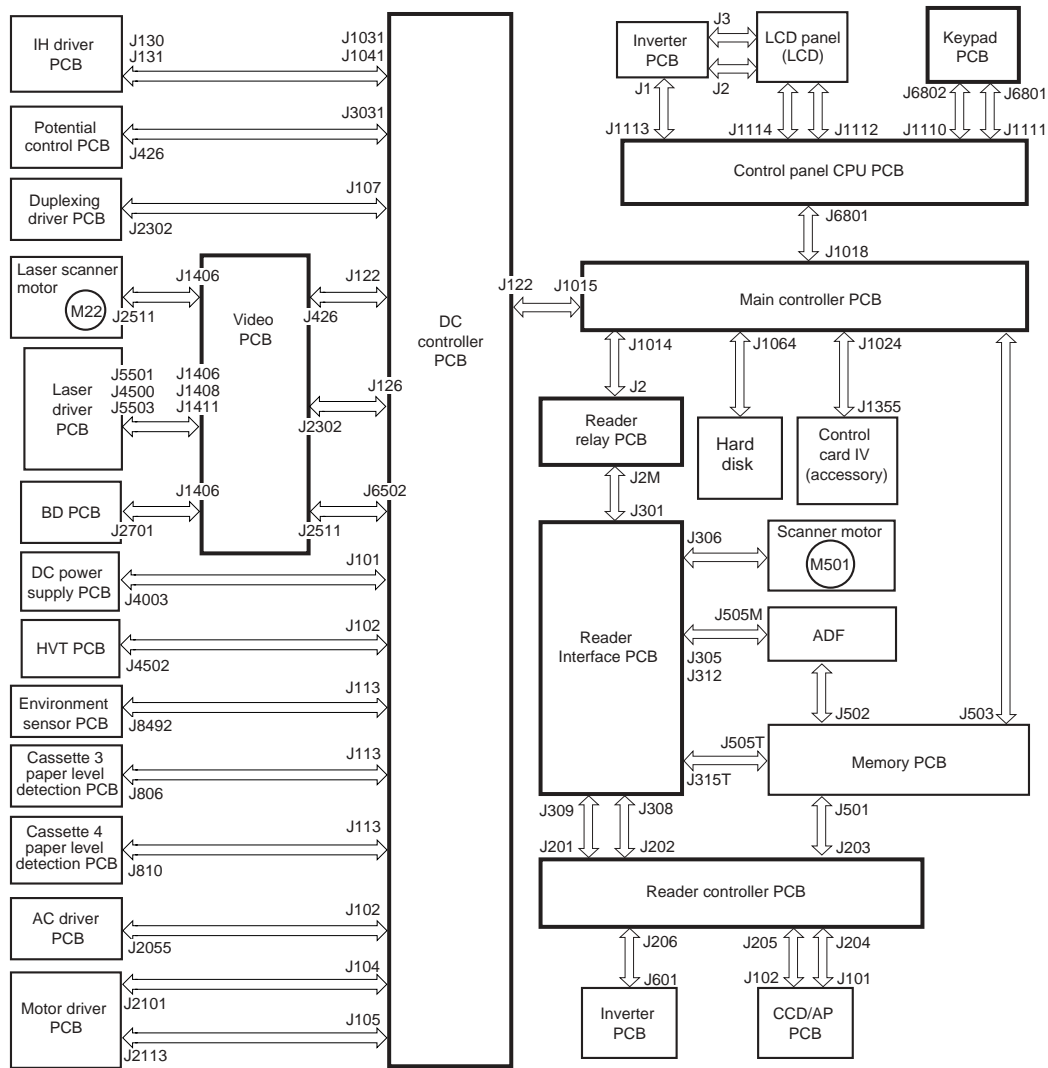

Note: The symbol  $\longleftrightarrow$  in the diagram indicates major wiring connections, and does not indicate the flow of signals.

F-3-2

### 3.1.3 Controlling the Main Motor (M2)

iR5065 / iR 5055 / iR5075 / iR5075N / iR5065N / iR5055N

The functions of the main motor control circuit are as shown in the following table, and its block diagram is shown in the following figure:

T-3-1

Item	Description
Power supply	24V is supplied by the DC controller PCB
drive signal	from the DC controller PCB (MAIN_M_ON)
Operating/driving	Collecting toner feedscrew Cleaning assembly Registration roller Manual feed pickup assembly Left deck feed roller 2 Developing assembly unit
Control	Turning on/off the motor Controlling the motor to a specific speed
Error detection	code E010

- 1) When the main motor drive signal (MAIN\_M\_ON) goes '1', the main motor starts to rotate.
- 2) When the main motor rotates, clock pulse signals (MAIN\_M\_FG) are generated. If the DC controller PCB detects an error in clock pulse signals, it will indicate "E010" in the control panel.

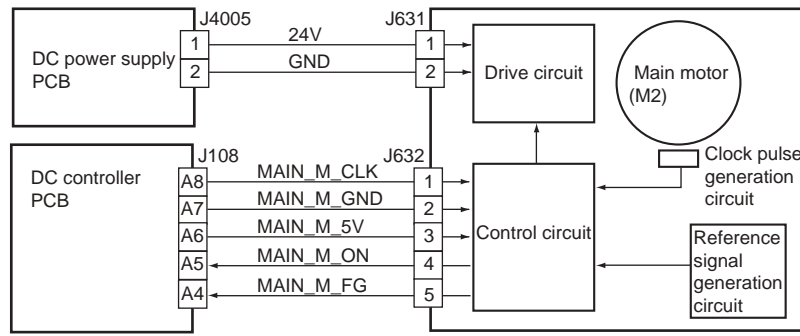

F-3-3

### 3.2 Basic Sequence

#### 3.2.1 Basic Sequence of Operation (at power-on; 30-sec start-up mode)

iR5065 / iR 5055 / iR5075 / iR5075N / iR5065N / iR5055N

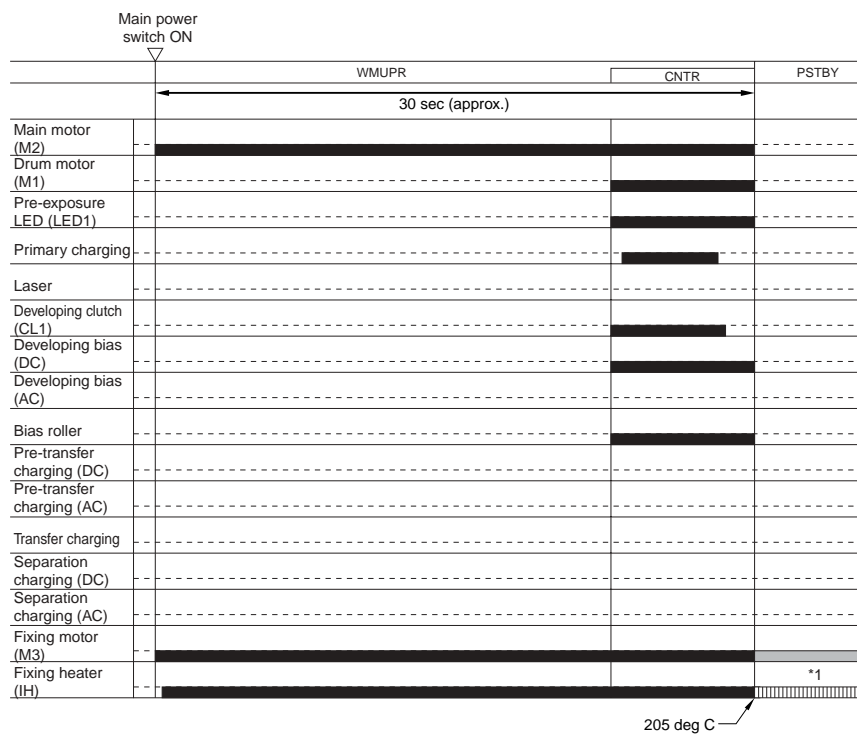

F-3-4

\*1: After a shift to standby, the fixing target temperature is decreased in 5-deg C increments at specific time intervals. When a specific temperature is reached, the fixing heater and the fixing motor are turned on and off to maintain the temperature.

T-3-2

Interval	Description
WMUPR (warm-up)	For 30 sec after the main power is turned on.
CNTR (control rotation)	The machine executes potential control for the photosensitive drum. In the case of 30-sec start-up mode, the machine measure the potential for a single rotation of the drum, and adjusts only the target output. (VL control)
PSTBY (print standby)	The machine is in a state in which it is ready to accept a copy/print request signal.

#### 3.2.2 Basic Sequence of Operation (at power-on; low-temperature start-up mode)

iR5065 / iR 5055 / iR5075 / iR5075N / iR5065N / iR5055N

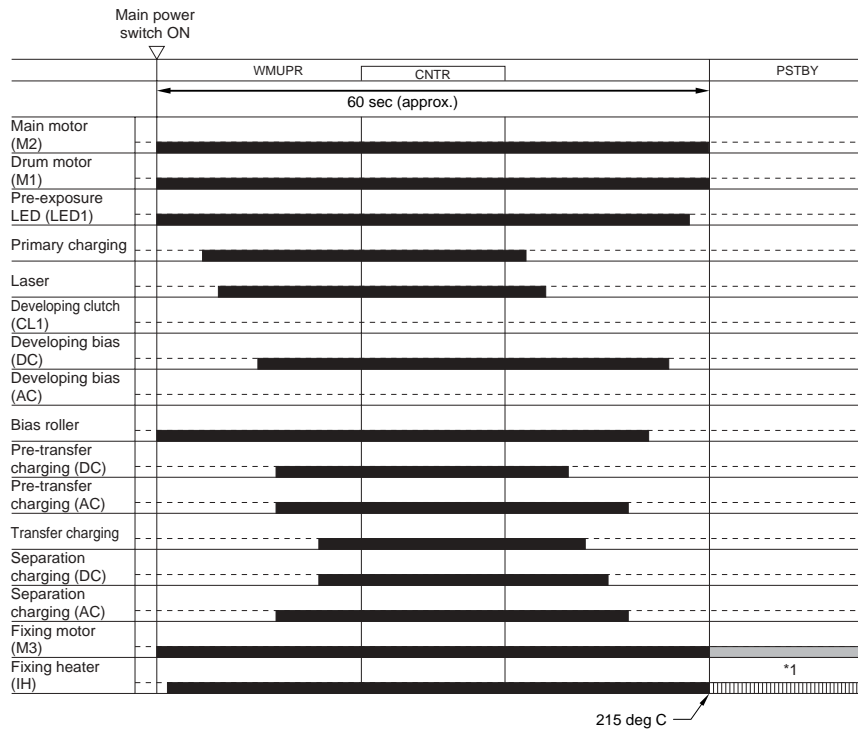

F-3-5

\*1: After a shift to standby, the fixing target temperature is decreased in 5-deg C increments at specific time intervals. When a specific temperature is reached, the fixing heater and the fixing motor are turned on and off to maintain the temperature.

T-3-3

Interval	Description
WMUPR (warm-up)	From when the main power is turned on until the fixing roller temperature reaches a specific level and, in addition, the potential control of the photosensitive drum ends, and as much as 60 sec passes from power-on.
CNTR (control rotation)	The machine executes potential control of the photosensitive drum. For each mode (i.e., copier, printer), the machine executes VD control (to adjust the primary discharge current) and VI control (to adjust the laser output), and determines Vdc (developing bias).
PSTBY (print standby)	The machine is in a state in which it is ready to accept a copy/print request signal.

### 3.2.3 Basic Sequence of Operation (at power-on; high-humidity start-up mode)

iR5065 / iR 5055 / iR5075 / iR5075N / iR5065N / iR5055N



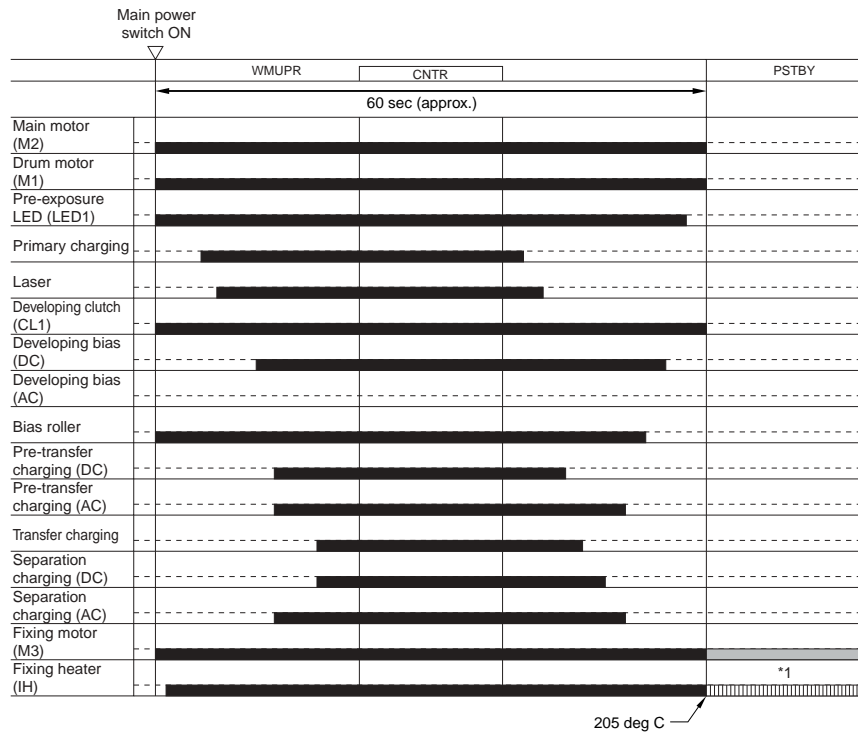

F-3-6

\*1: After a shift to standby, the fixing target temperature is decreased in 5-deg C increments at specific time intervals. When a specific temperature is reached, the fixing heater and the fixing motor are turned on and off to maintain the temperature.

T-3-4

Interval	Description
WMUPR (warm-up)	From when the main power is turned on until the fixing roller temperature reaches a specific level, the potential control of the photosensitive drum ends, and as much as 60 sec passes from power-on.
CNTR (control rotation)	The machine executes potential control of the photosensitive drum. For each mode (i.e., copier, printer), it executes VD control (to adjust the primary discharge current) and VL control (to adjust the laser output) and determines Vdc (developing bias).
PSTBY (print standby)	The machine is in a state in which it is ready to accept a copy/print request signal.

### 3.2.4 Basic Sequence of Operation (at time of copying/printing)

iR5065 / iR 5055 / iR5075 / iR5075N / iR5065N / iR5055N

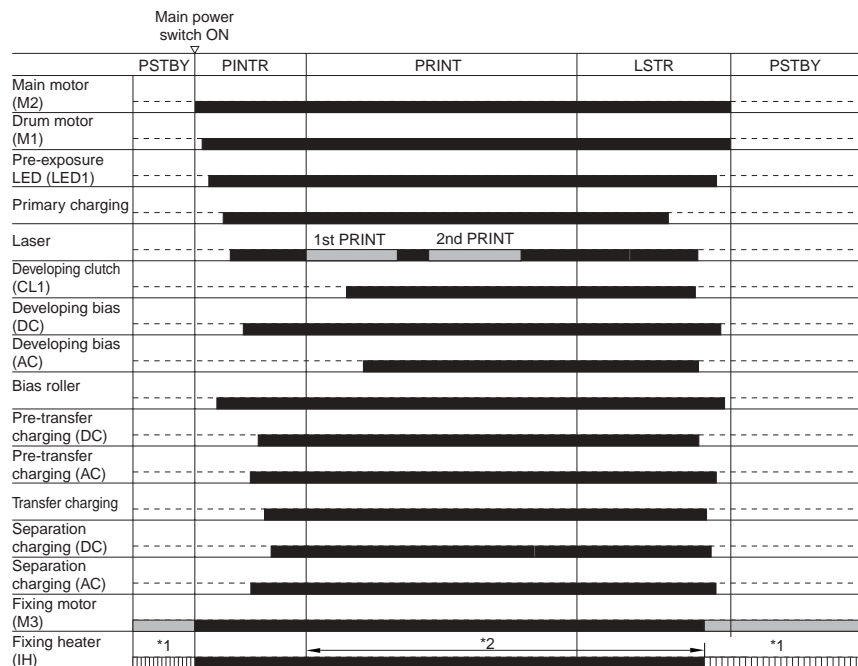

F-3-7

\*1: temperature control under way for fixing standby mode.

\*2: as in the case of standby, while copying/printing is under way, the fixing target temperature is decreased to suit the passage of time after the end of start-up.

T-3-5

<b>Interval</b>	<b>Description</b>
PSTBY (standby)	The machine is in a state in which it can accept a copy/print request signal.
PNTR (initial rotation)	From when a print request signal is received until the image signal is generated.
PRINT (print)	The machine is in a state in which a toner image is transferred to paper and the paper is discharged.
LSTR (last rotation)	The machine is in a state in which paper has been discharged and all drive has ended.

---

## Chapter 4 Main Controller

---



---

# Contents

4.1 Construction .....	4-1
4.1.1 Construction and Mechanisms .....	4-1
4.2 Construction of the Electrical Circuitry .....	4-1
4.2.1 Main Controller PCB .....	4-1
4.2.2 HDD .....	4-2
4.3 Start-Up Sequence .....	4-4
4.3.1 Overview .....	4-4
4.3.2 Start-Up Sequence .....	4-4
4.4 Shut-Down Sequence .....	4-6
4.4.1 Overview .....	4-6
4.4.2 Flow of Operation .....	4-6
4.5 Image Processing .....	4-6
4.5.1 Overview of the Image Flow .....	4-6
4.5.2 Construction of the Image Processing Module .....	4-7
4.5.3 Reader Unit Input Image Processing .....	4-7
4.5.4 Compression/ Extension/ Editing Block .....	4-8
4.5.5 Printer unit Output Image Processing .....	4-8
4.6 Flow of Image Data .....	4-9
4.6.1 Flow of Image Data According to Copy Functions .....	4-9
4.6.2 Flow of Image Data for the Box Function .....	4-9
4.6.3 Flow of Image Data for the SEND Function .....	4-10
4.6.4 Flow of Image Data for the Fax Transmission .....	4-10
4.6.5 Flow of Image Data for the Fax Reception Function .....	4-11
4.6.6 Flow of Image Data for the PDL Function .....	4-12
4.7 Parts Replacement Procedure .....	4-13
4.7.1 Main Controller Box .....	4-13
4.7.1.1 Before Removing the Main Controller Box .....	4-13
4.7.1.2 Removing the Main Controller Box .....	4-13
4.7.2 Main Controller PCB .....	4-13
4.7.2.1 Before Removing the Main Controller PCB .....	4-13
4.7.2.2 Removing the Main Controller PCB .....	4-13
4.7.2.3 When Replacing the Main Controller PCB .....	4-14
4.7.3 SDRAM .....	4-14
4.7.3.1 Before Removing the SDRAM .....	4-14
4.7.3.2 Removing the SDRAM .....	4-14
4.7.4 Boot ROM .....	4-14
4.7.4.1 Before Removing the Boot ROM .....	4-14
4.7.4.2 Removing the Boot ROM .....	4-14
4.7.5 HDD .....	4-15
4.7.5.1 Before Removing HDD .....	4-15
4.7.5.2 Removing the HDD .....	4-15
4.7.5.3 After Replacing the HDD .....	4-15
4.7.6 Video PCB .....	4-15
4.7.6.1 Before Removing the Video PCB .....	4-15
4.7.6.2 Removing the Video PCB .....	4-15
4.7.7 Controller Fan .....	4-16
4.7.7.1 Before Removing the Controller Cooling Fan .....	4-16
4.7.7.2 Removing the Controller Cooling Fan .....	4-16



## 4.1 Construction

### 4.1.1 Construction and Mechanisms

iR5065 / iR 5055 / iR5075 / iR5075N / iR5065N / iR5055N

The machine's main controller block consists of the following and has the following functions:

T-4-1	
Item	Description
Main controller PCB	Controls system operation, memory, printer unit output, image processing, scanner unit image input processing, rendering, color LCD controller, card reader unit interface, fax image processing, etc.
SRAM	Retains service mode settings (by SRAM), HDD management information
Image memory (DDR SDRAM)	Temporarily retains image data (1024 MB)
BOOTROM	Stores boot program
HDD	Stores system software, retains image data for Box/Fax function (40 GB)
USB port x 2	USB2.0 interface
Ethernet port (10/100Base-T)	Ethernet interface
Video PCB	Pixel/line conversion, laser scanner motor control

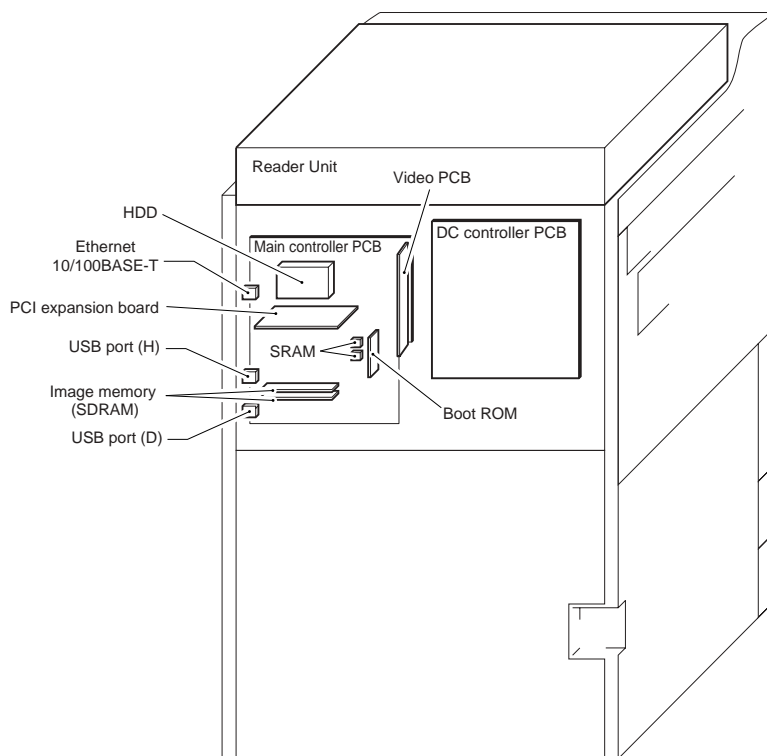

F-4-1

## 4.2 Construction of the Electrical Circuitry

### 4.2.1 Main Controller PCB

iR5065 / iR 5055 / iR5075 / iR5075N / iR5065N / iR5055N

The following is a diagram showing the major control mechanisms of the main controller according to connectors:

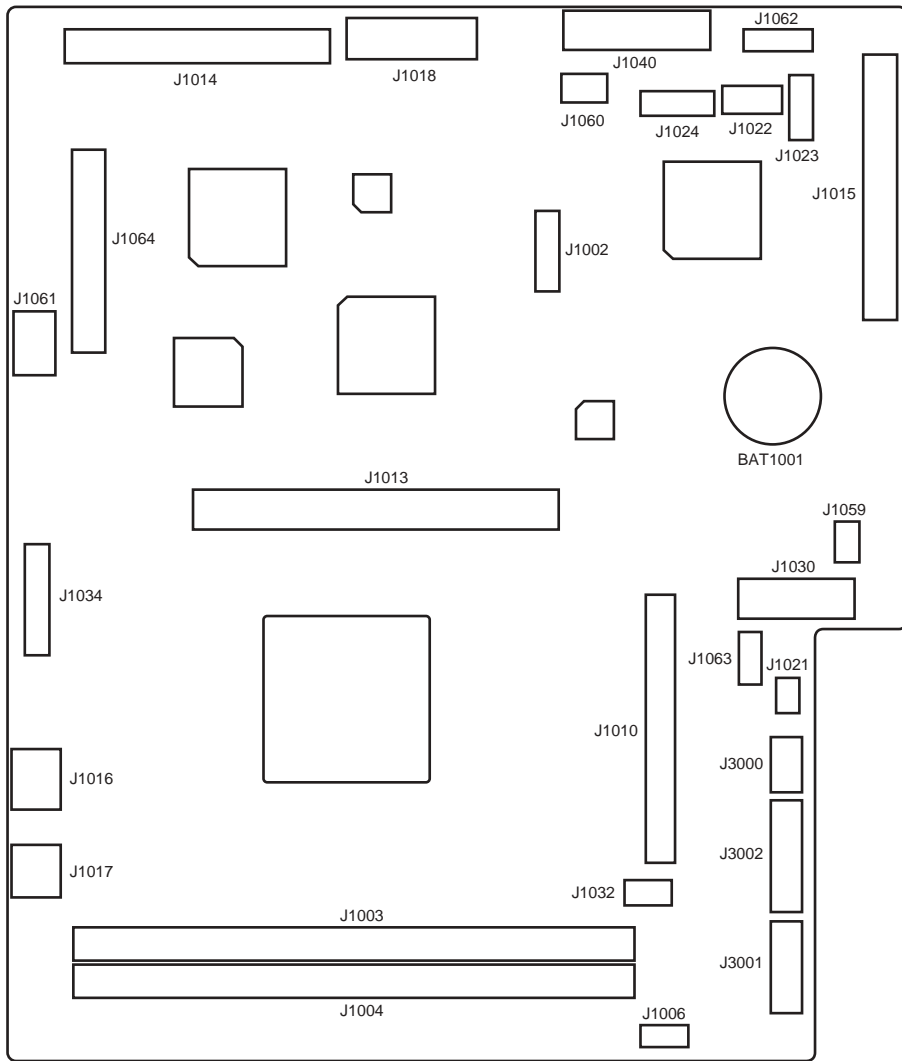

F-4-2  
T-4-2

Connector	Description	Connector	Description
J1003	DDR SDRAM connection slot	J1024	New card reader connector
J1004		J1060	CC-V connector
J1010	Boot ROM connector slot	J1061	LAN connector
J1013	PCI enhance board connection slot	J1062	New coin robo connector
J1014	Reader interface connector	J1064	Hard disk connector
J1015	Printer interface connector	J3000	Power supply connector (5V non all night)
J1016	USB host interface connector	J3001	Power supply connector (3.3V non all night)
J1017	USB device interface connector	J3002	Power supply connector (3.3V all night)
J1018	Control panel connector		
J1021	Power supply control connector		

**4.2.2 HDD**

iR5065 / iR 5055 / iR5075 / iR5075N / iR5065N / iR5055N

The HDD is divided into 11 partitions (blocks), each assigned with specific functions.

T-4-3

Partition	Description
FSTDEV	Collects compressed image data.
TMP_GEN	Stores temporary files, log data.



Partition	Description
TMP_PSS	PDL spool
TMP_FAX	Ensures fax reception.
APL_SEND	Stores user data (address book, transfer settings).
APL_MEAP	Stores MEAP applications.
APL_GEN	Mode memory data, standard mode data History (e.g., print job history) iFax image data Fax image data Other
IMG_MNG	Stores file management table, profile.
PDL_DEV	Stores PDL font, etc.
BOOTDEV	Stores execution module, message data file, RUI content, etc.
FSTCDEV	Chasing (not used)

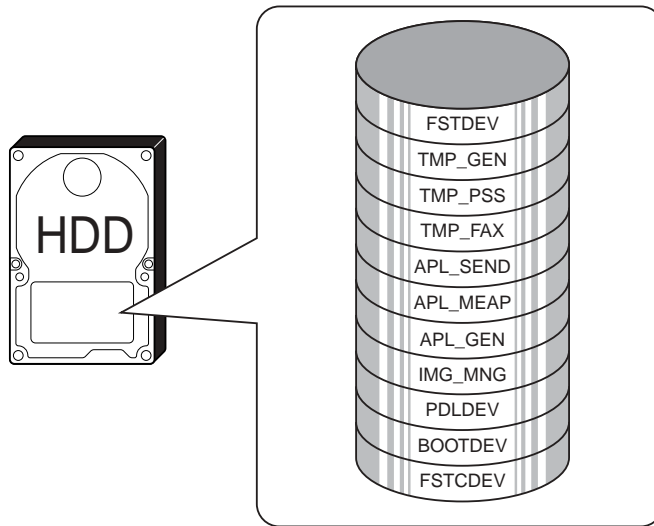

F-4-3

The following shows the construction of the machine's system software:

T-4-4

System Software	Description	Location	Remarks
System	System module (controls mechanism as a whole)	HDD (BOOTDEV)	
Language	Language module (controls LCD indications)	HDD (BOOTDEV)	
RUI	Remote user interface module	HDD (BOOTDEV)	
Boot	Starts up the machine	Boot ROM	DIMM
G3FAX	Controls G3 Fax (2-port)	G3 Fax board	DIMM
	Controls G3 Fax (1-port)	HDD (BOOTDEV)	
Dcon	Controls the DC controller	DC controller PCB	Flash ROM (soldered)
Rcon	Controls the Reader controller	Reader controller PCB	Flash ROM (soldered)
Meapcont	Controls MEAP applications	HDD (BOOTDEV)	
SDICT	OCR dictionary	HDD (BOOTDEV)	
KEY	encryption communication key	HDD (BOOTDEV)	

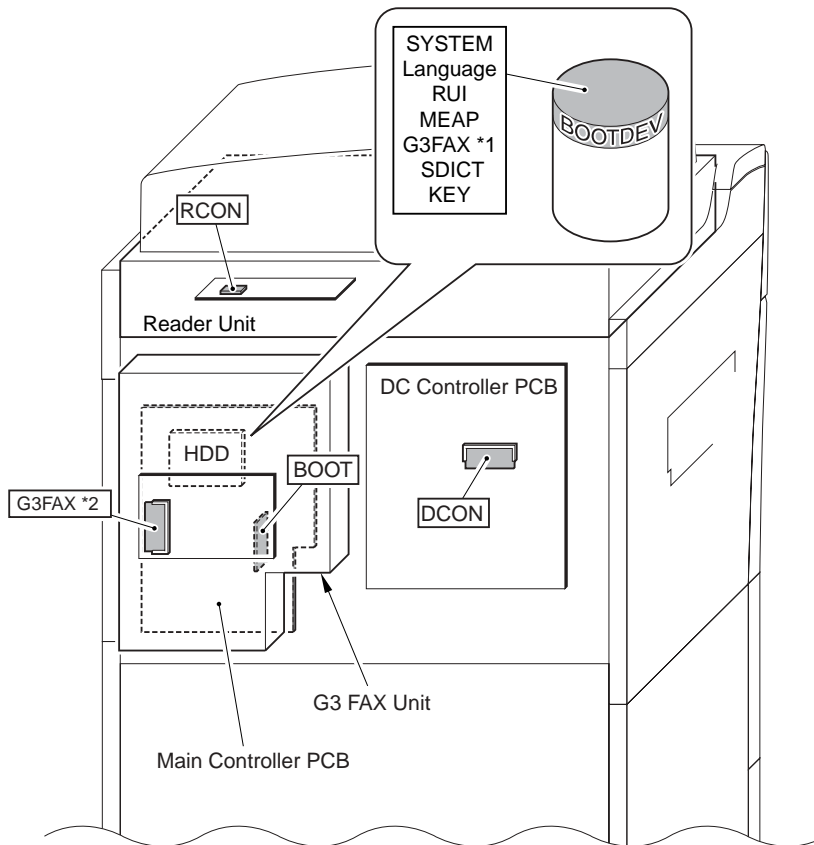

F-4-4

\*1: 1-port FAX  
 \*2: 2-port FAX

### 4.3 Start-Up Sequence

#### 4.3.1 Overview

iR5065 / iR 5055 / iR5075 / iR5075N / iR5065N / iR5055N

The system software used to control the machine is stored on the HDD. When the machine is started, the CPU on the main controller PCB reads the system software from the HDD according to the instructions of the boot ROM boot program, and writes it to the image memory (SDRAM) of the controller PCB. While the CPU reads the system software from the HDD to the image memory (DRAM), the control panel shows the following screen, using a progress bar to indicate the progress of the start-up sequence.

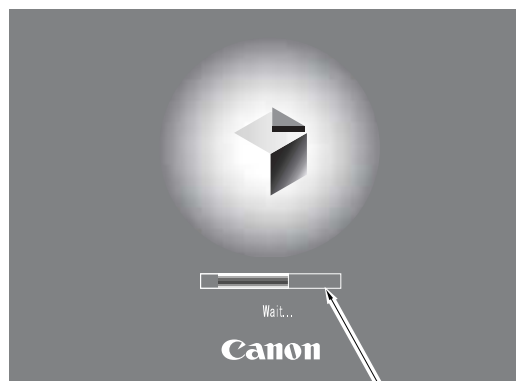

Progress bar

F-4-5



Do not turn off the main power while the progress bar is indicated, as access is being made to the HDD. Turning off the power can cause a fault on the HDD (identified by E602).

#### 4.3.2 Start-Up Sequence

iR5065 / iR 5055 / iR5075 / iR5075N / iR5065N / iR5055N

<Boot ROM Area>

**- Self Diagnosis Program (interval 1)**

The self-diagnosis program is run by the CPU on the main controller PCB when the main power switch is turned on. The program is used to check the condition of the image memory (SDRAM) and the HDD. The machine will indicate an error code if it finds a fault while running the program.

**- Boot Program (interval 2)**

When the self-diagnosis program ends normally, the CPU on the main controller PCB executes the boot program. The program is used to read the system software from the HDD to write it into the image memory (SDRAM).

**- Image Memory (SDRAM) Area (interval 3)**

The system software written by the boot program initializes the various functional blocks (e.g., I/F settings of the main controller). When all the foregoing ends normally, the machine becomes ready to accept a job (i.e., the control panel shows the Operation screen, and the LED on the Start key changes from red to green).

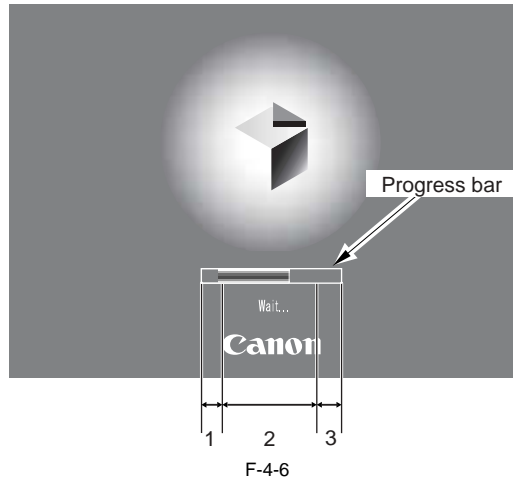

- While the Self-Diagnosis Program Is Being Executed

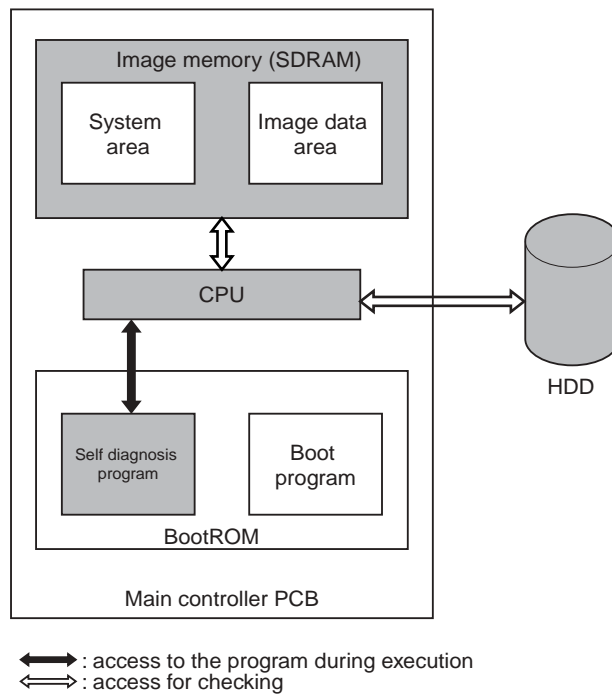

F-4-7

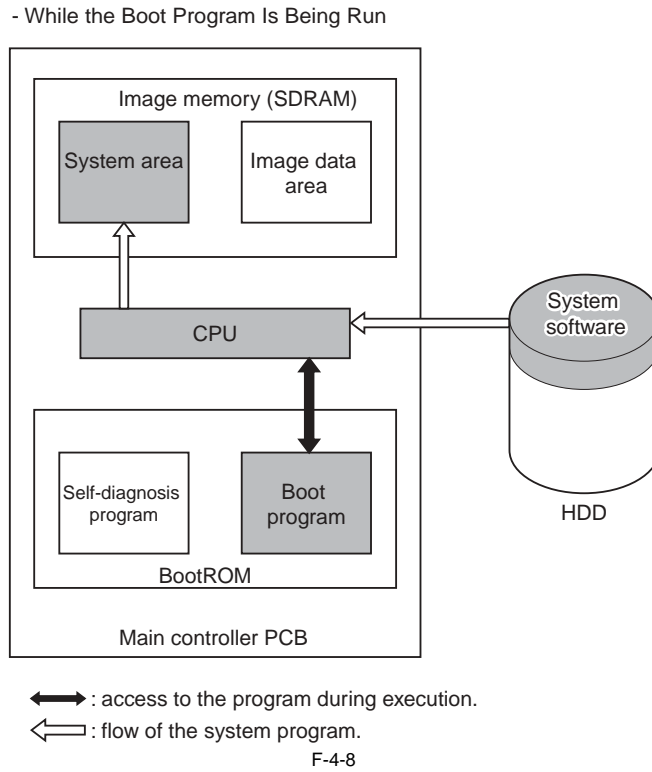

## 4.4 Shut-Down Sequence

### 4.4.1 Overview

iR5065 / iR 5055 / iR5075 / iR5075N / iR5065N / iR5055N

If the main power switch is turned off while the machine is accessing its HDD, damage can well occur on the HDD. To avoid such damage, the machine is provided with a shut-down sequence.

### 4.4.2 Flow of Operation

iR5065 / iR 5055 / iR5075 / iR5075N / iR5065N / iR5055N

The following diagram shows the flow of shut-down operation:

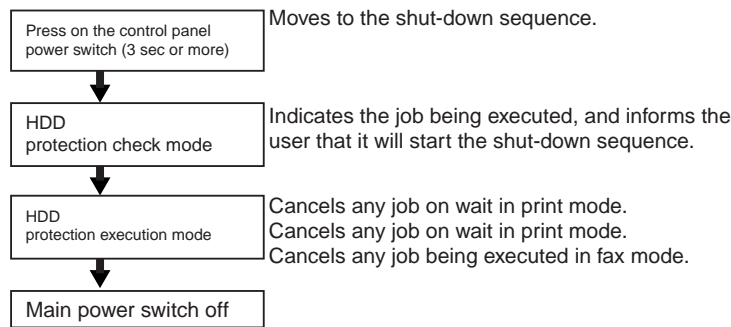

F-4-9

## 4.5 Image Processing

### 4.5.1 Overview of the Image Flow

iR5065 / iR 5055 / iR5075 / iR5075N / iR5065N / iR5055N

The following shows the flow of images in relation to the machine's functions:

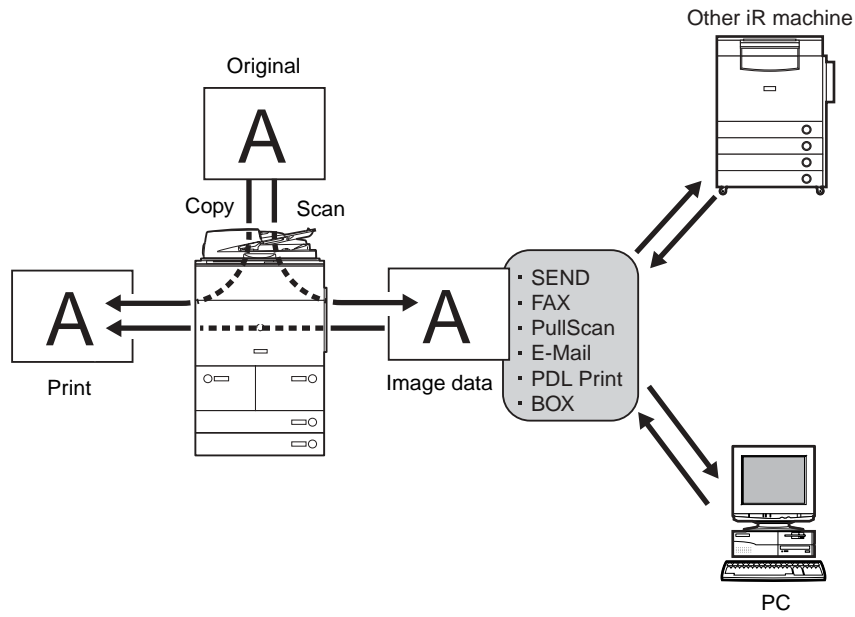

F-4-10

### 4.5.2 Construction of the Image Processing Module

iR5065 / iR 5055 / iR5075 / iR5075N / iR5065N / iR5055N

The machine's major image processing is executed by the main controller PCB. The following shows the construction of the modules associated with image processing:

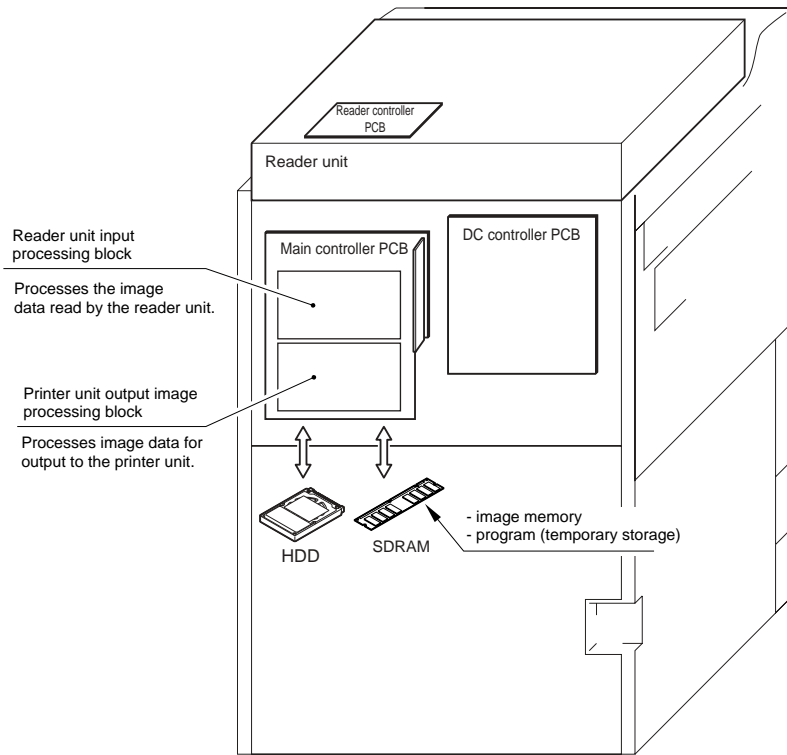

F-4-11

### 4.5.3 Reader Unit Input Image Processing

iR5065 / iR 5055 / iR5075 / iR5075N / iR5065N / iR5055N

The image data collected by the contact image sensor is processed by the main controller PCB.

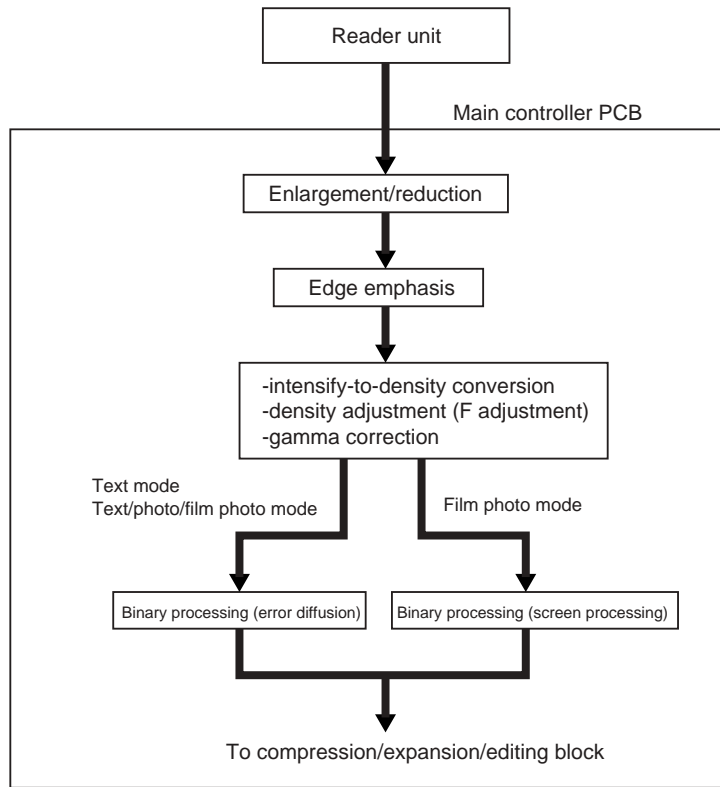

F-4-12

**4.5.4 Compression/ Extension/ Editing Block**

iR5065 / iR 5055 / iR5075 / iR5075N / iR5065N / iR5055N

Here, image data is processed for compression, extension, and editing.

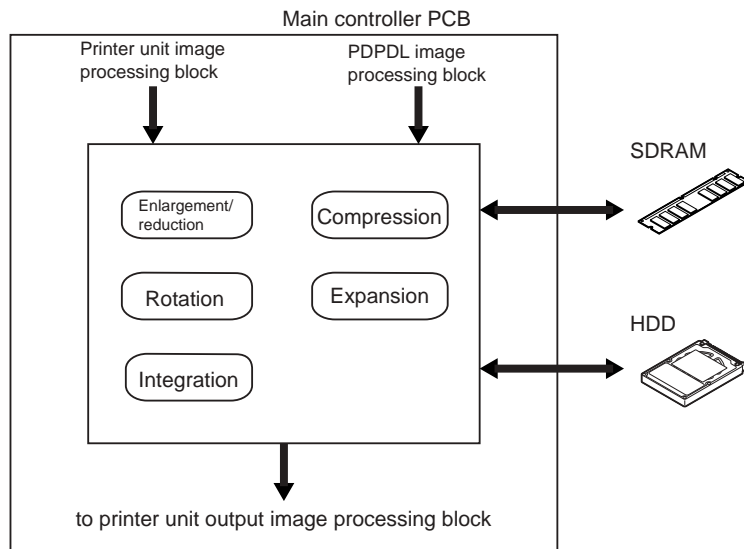

F-4-13

**4.5.5 Printer unit Output Image Processing**

iR5065 / iR 5055 / iR5075 / iR5075N / iR5065N / iR5055N

The main controller processes the image data coming from the printer unit for output to the printer unit.

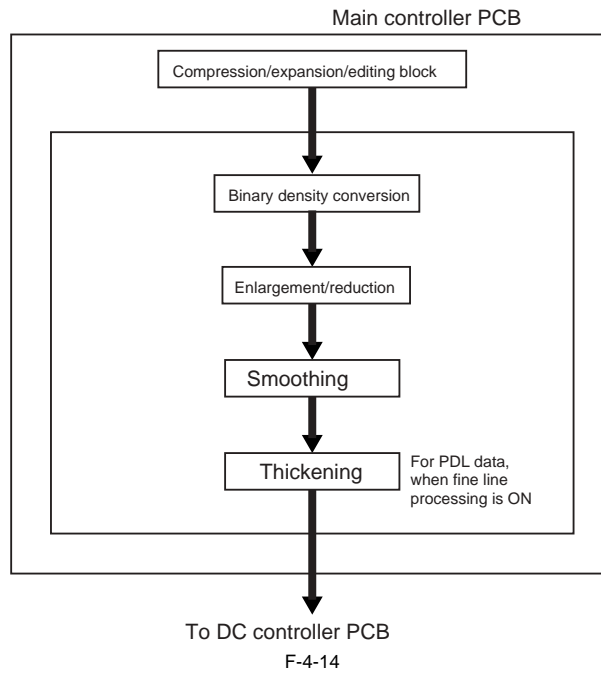

## 4.6 Flow of Image Data

### 4.6.1 Flow of Image Data According to Copy Functions

iR5065 / iR 5055 / iR5075 / iR5075N / iR5065N / iR5055N

The following is the flow of image data when the Copy Function is in use:

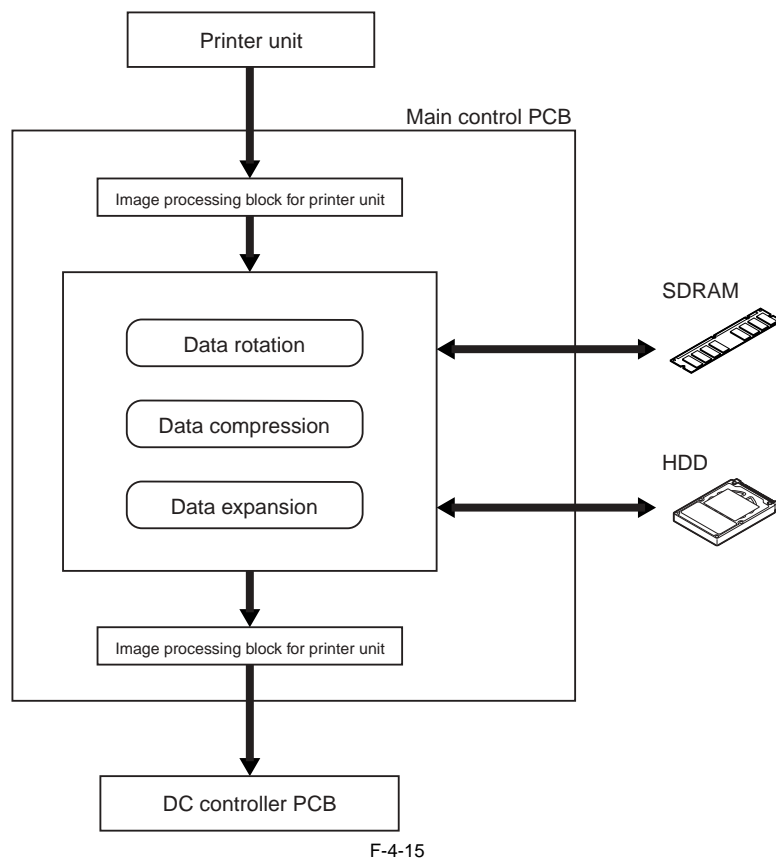

### 4.6.2 Flow of Image Data for the Box Function

iR5065 / iR 5055 / iR5075 / iR5075N / iR5065N / iR5055N

The following is the flow of image data when the Box function is in use:

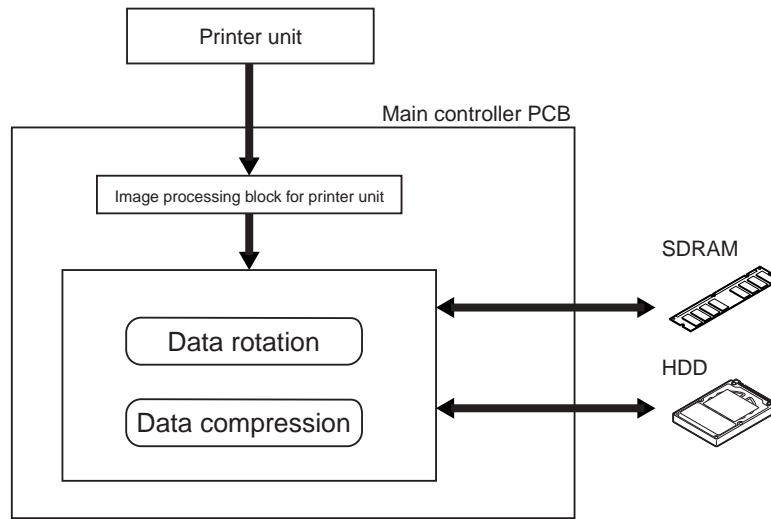

F-4-16

### 4.6.3 Flow of Image Data for the SEND Function

iR5065 / iR 5055 / iR5075 / iR5075N / iR5065N / iR5055N

The following is the flow of image data when the SEND function is in use.

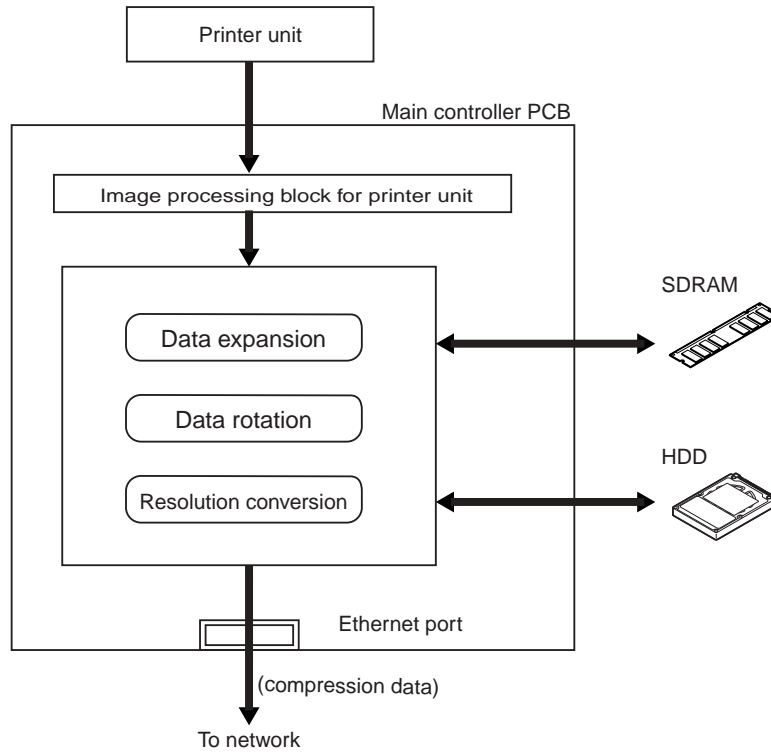

F-4-17

### 4.6.4 Flow of Image Data for the Fax Transmission

iR5065 / iR 5055 / iR5075 / iR5075N / iR5065N / iR5055N

The following is the flow of image data when the fax transmission function is in use:



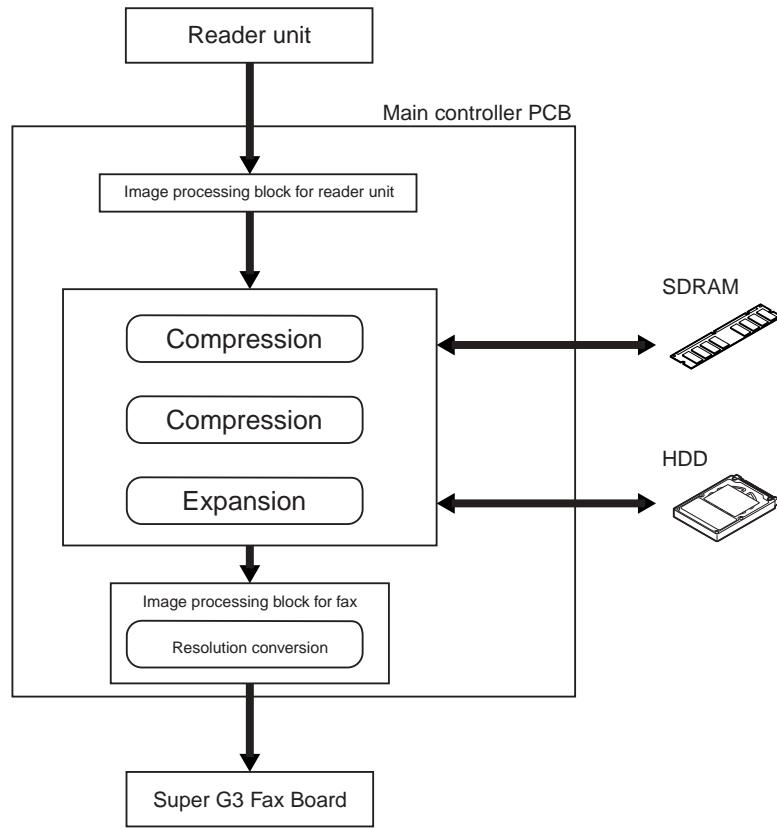

F-4-18

**4.6.5 Flow of Image Data for the Fax Reception Function**

iR5065 / iR 5055 / iR5075 / iR5075N / iR5065N / iR5055N

The following is the flow of image data when the fax reception function is in use:

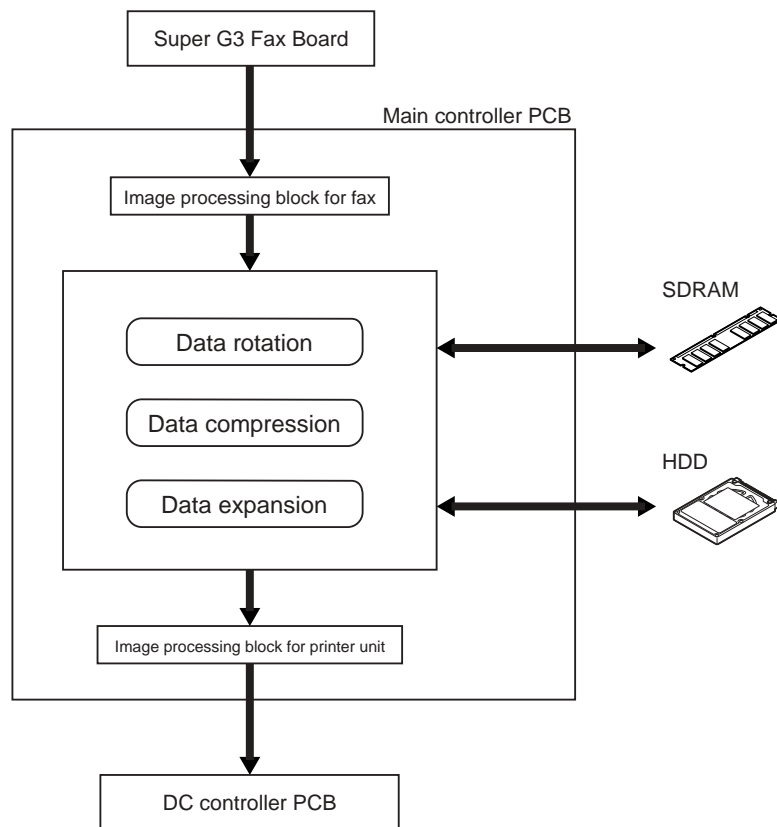

F-4-19

### 4.6.6 Flow of Image Data for the PDL Function

iR5065 / iR 5055 / iR5075 / iR5075N / iR5065N / iR5055N

The following is the flow of image data when the PDL function is in use:

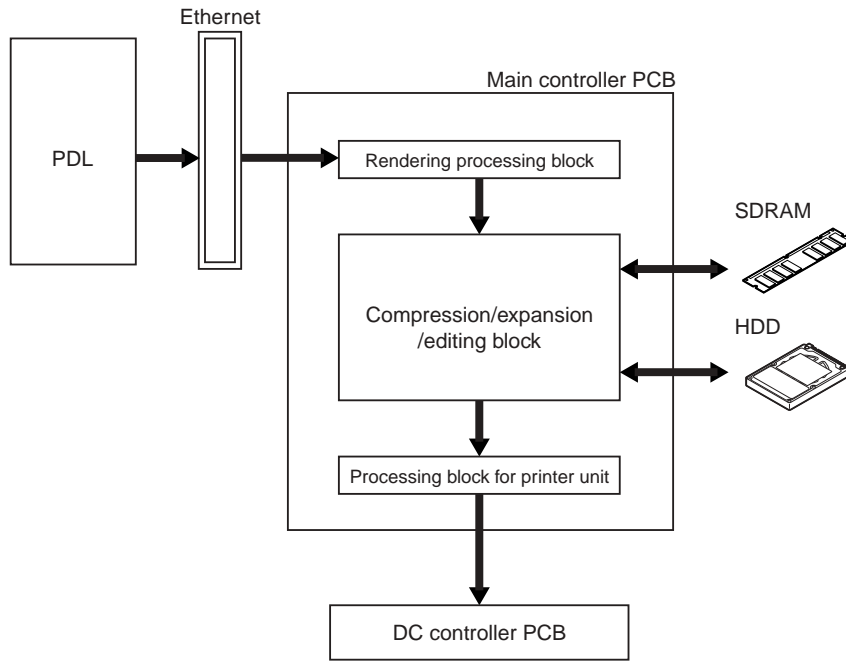

F-4-20

## 4.7 Parts Replacement Procedure

### 4.7.1 Main Controller Box

#### 4.7.1.1 Before Removing the Main Controller Box

iR5065 / iR 5055 / iR5075 / iR5075N / iR5065N / iR5055N

- 1) Detach the rear cover (upper). (page 10-13)Reference[Removing the Rear Cover (Upper)]
- 2) Detach the main controller box cover. (page 10-17)Reference[Removing the Main Controller Box Cover]
- 3) Detach the right cover (upper rear). (page 10-12)Reference[Removing the Right Cover (Upper Rear)]

#### 4.7.1.2 Removing the Main Controller Box

iR5065 / iR 5055 / iR5075 / iR5075N / iR5065N / iR5055N

- 1) Disconnect the 7 connectors [4] of the video PCB [1].
  - 3 Wire saddle [2] (to free the harness)
  - 1 Reuse band [3]

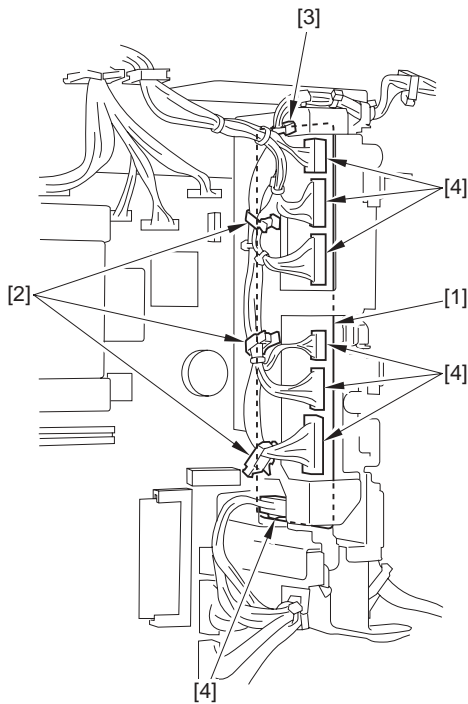

F-4-21

- 2) Disconnect all the connectors of the main controller PCB, and detach the main controller box [3].
  - 5 Edge saddle [1] (to free the harness)
  - 4 Screw [2]

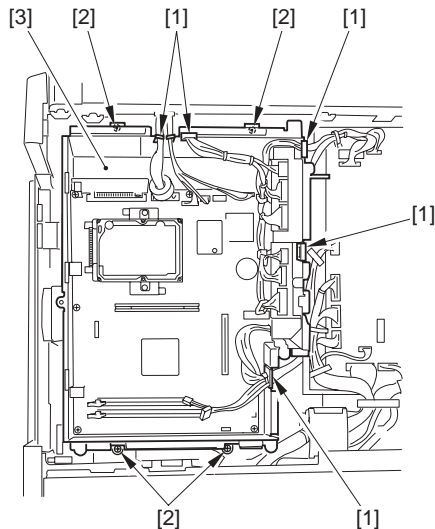

F-4-22

### 4.7.2 Main Controller PCB

#### 4.7.2.1 Before Removing the Main Controller PCB

iR5065 / iR 5055 / iR5075 / iR5075N / iR5065N / iR5055N

- 1) Detach the rear cover (upper). (page 10-13)Reference[Removing the Rear Cover (Upper)]
- 2) Detach the main controller box cover. (page 10-17)Reference[Removing the Main Controller Box Cover]
- 3) Detach the right cover (upper rear). (page 10-12)Reference[Removing the Right Cover (Upper Rear)]

#### 4.7.2.2 Removing the Main Controller PCB

iR5065 / iR 5055 / iR5075 / iR5075N / iR5065N / iR5055N

- 1) Remove the 4 screws [1].

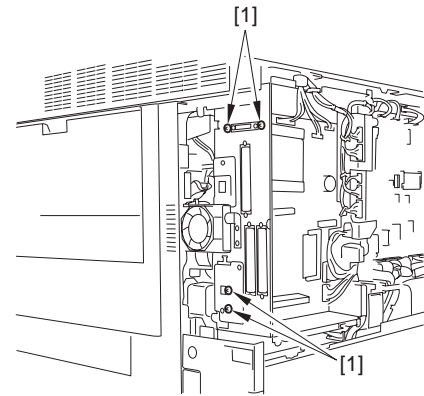

F-4-23

- 2) Detach the reader relay PCB [1] from the main controller PCB.

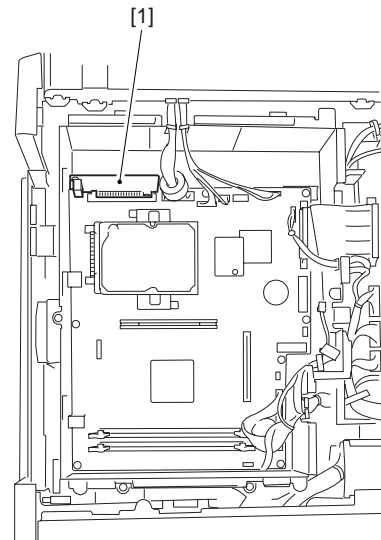

F-4-24

- 3) Detach the Video PCB unit [3].
  - Screw [1] 2pc.
  - Connector [2] 7pc.

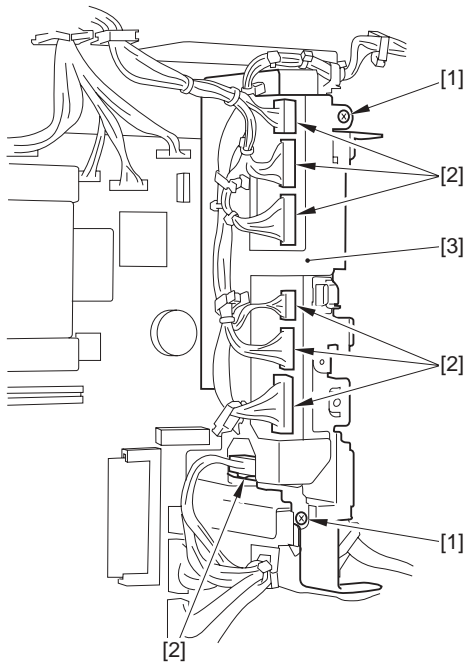

F-4-25

- 4) Disconnect all the connectors of the main controller PCB, and remove the main controller PCB [2].  
- Screw [1] 8pc.

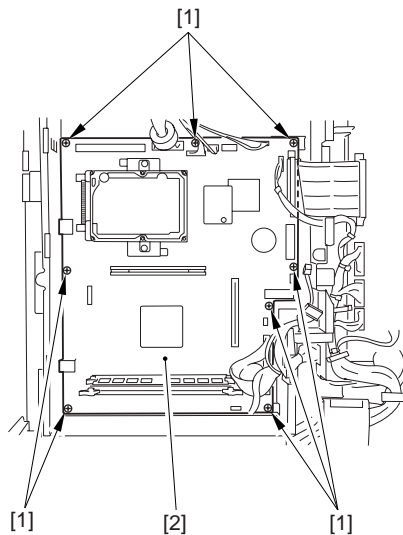

F-4-26

**4.7.2.3 When Replacing the Main Controller PCB**

iR5065 / iR 5055 / iR5075 / iR5075N / iR5065N / iR5055N

Upload each setting/registration data stored in SRAM of the main controller PCB onto the PC by using SST. See the chapter ‘Version Upgrading’ for its operation procedure.  
If you are replacing the main controller PCB, be sure to transfer the following components from the old to new PCB.

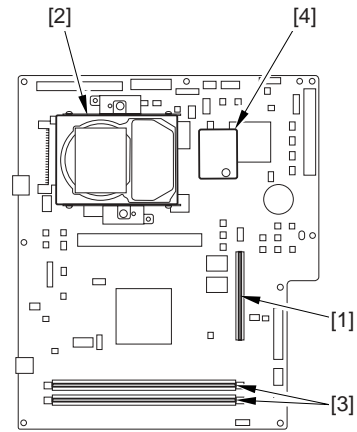

F-4-27

- [1] Boot ROM
- [2] Hard disk
- [3] Image memory (SDRAM)
- [4] Counter memory PCB

**4.7.3 SDRAM**

**4.7.3.1 Before Removing the SDRAM**

iR5065 / iR 5055 / iR5075 / iR5075N / iR5065N / iR5055N

- 1) Detach the rear cover (upper). (page 10-13)Reference[Removing the Rear Cover (Upper)]
- 2) Detach the main controller box cover.(page 10-17)Reference[Removing the Main Controller Box Cover]

**4.7.3.2 Removing the SDRAM**

iR5065 / iR 5055 / iR5075 / iR5075N / iR5065N / iR5055N

- 1) Open the 2 arms [1], and release the lock; then, detach the SDRAM [2].

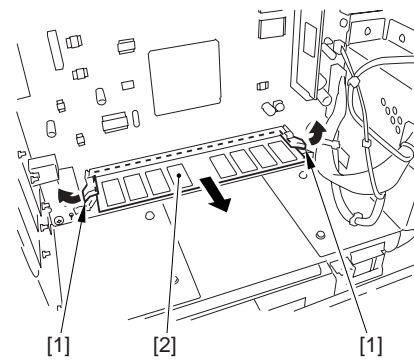

F-4-28

**4.7.4 Boot ROM**

**4.7.4.1 Before Removing the Boot ROM**

iR5065 / iR 5055 / iR5075 / iR5075N / iR5065N / iR5055N

- 1) Detach the rear cover (upper).(page 10-13)Reference[Removing the Rear Cover (Upper)]
- 2) Detach the main controller box cover.(page 10-17)Reference[Removing the Main Controller Box Cover]

**4.7.4.2 Removing the Boot ROM**

iR5065 / iR 5055 / iR5075 / iR5075N / iR5065N / iR5055N

- 1) Detach the Boot ROM [1].

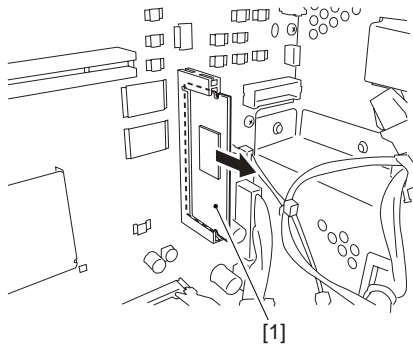

F-4-29

## 4.7.5 HDD

### 4.7.5.1 Before Removing HDD

iR5065 / iR 5055 / iR5075 / iR5075N / iR5065N / iR5055N

- 1) Detach the rear cover (upper). (page 10-13) Reference[Removing the Rear Cover (Upper)]
- 2) Detach the main controller box cover. (page 10-17) Reference[Removing the Main Controller Box Cover]

### 4.7.5.2 Removing the HDD

iR5065 / iR 5055 / iR5075 / iR5075N / iR5065N / iR5055N

- 1) Detach the counter memory PCB [2].  
- 1 Screw [1]

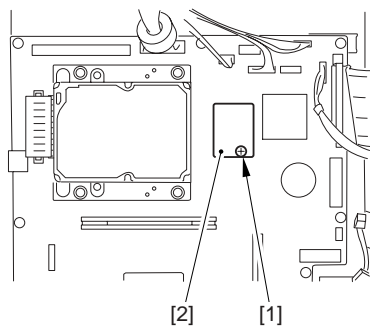

F-4-30



Be sure to remove the counter memory PCB. If you hit the hard disk against the counter memory PCB, the impact can leave appreciable damage.

- 2) After detaching the hard disk [2] in the direction of the arrow, disconnect the connector [3].  
- 2 Screw [1]

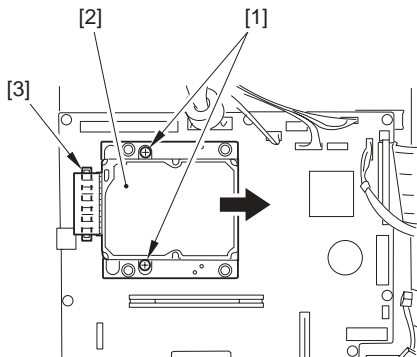

F-4-31

### 4.7.5.3 After Replacing the HDD

iR5065 / iR 5055 / iR5075 / iR5075N / iR5065N / iR5055N

- Formatting the HDD

Start up the machine in the safe mode (i.e., while holding down the 2 and 8 keys, turn on the main power).

Using the HD format function of the SST, format all partitions (BOOTDEV/PDLDEV/FSTDEV/FSTCDEV/TMP\_GEN/TMP\_FAX/TMP\_PSS/

IMG\_MNG/APL\_MEAP/APL\_GEN/APL\_SEND). (For details, see the descriptions given for upgrading.)

- Downloading the system software

Using the SST, download the following: System, Language, RUI, MEAP-CONT (Meap content), SDICT (OCR dictionary), KEY (key/certificate for encrypted communication), TTS (audio dictionary).

## 4.7.6 Video PCB

### 4.7.6.1 Before Removing the Video PCB

iR5065 / iR 5055 / iR5075 / iR5075N / iR5065N / iR5055N

- 1) Detach the rear cover (upper). (page 10-13) Reference[Removing the Rear Cover (Upper)]
- 2) Detach the main controller box cover. (page 10-17) Reference[Removing the Main Controller Box Cover]

### 4.7.6.2 Removing the Video PCB

iR5065 / iR 5055 / iR5075 / iR5075N / iR5065N / iR5055N

- 1) Disconnect the 7 connectors [4] of the Video PCB [1].  
- 3 Wire saddle [2] (to free the harness)  
- 1 Reuse band [3]

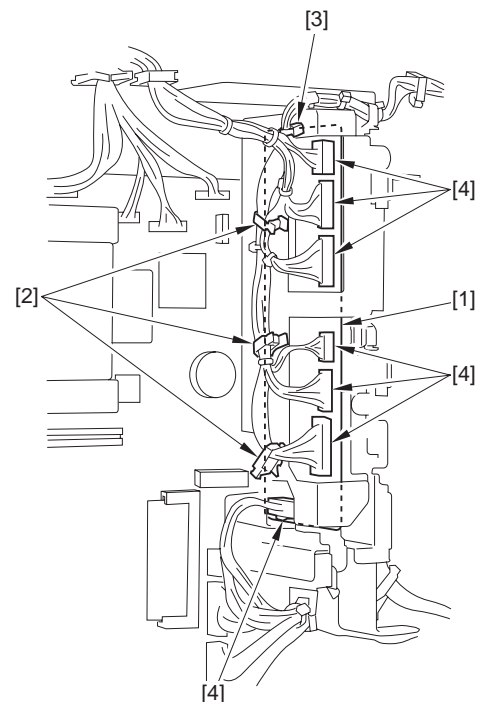

F-4-32

- 2) Detach the Video PCB [2].  
- 2 Screw [1]

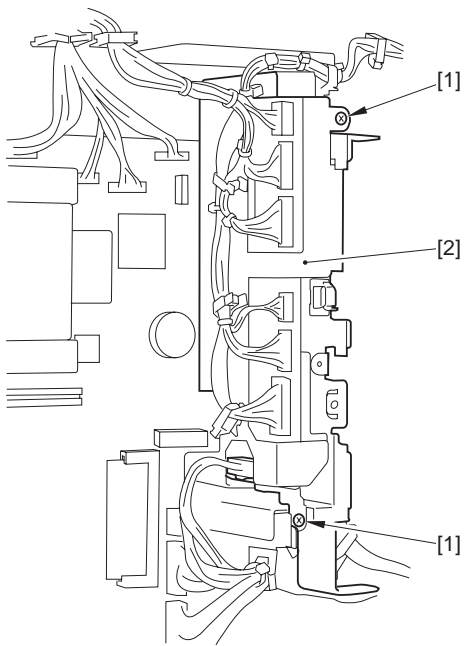

F-4-33

#### 4.7.7 Controller Fan

##### 4.7.7.1 Before Removing the Controller Cooling Fan

iR5065 / iR 5055 / iR5075 / iR5075N / iR5065N / iR5055N

- 1) Detach the right cover (upper rear). (page 10-12) Reference[Removing the Right Cover (Upper Rear)]
- 2) Detach the right cover (upper). (page 10-12) Reference[Removing the Right Cover (Upper)]
- 3) Remove the right door unit (upper). (page 10-34) Reference[Removing the Right Door Unit (Upper)]

##### 4.7.7.2 Removing the Controller Cooling Fan

iR5065 / iR 5055 / iR5075 / iR5075N / iR5065N / iR5055N

- 1) Disconnect the 1 connector [1], and free the fan harness from the clamp; then, detach the controller cooling fan [3].  
- 2 Screw [2]

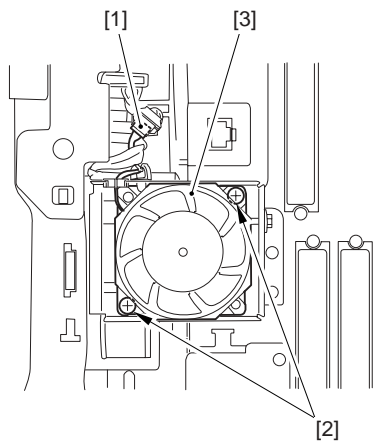

F-4-34

---

## Chapter 5 Original Exposure System

---





---

# Contents

5.1 Construction .....	5-1
5.1.1 Specifications, Controls, and Functions.....	5-1
5.1.2 Major Components.....	5-1
5.1.3 Construction of the Control System.....	5-2
5.1.4 Reader Controller PCB .....	5-3
5.2 Basic Sequence .....	5-4
5.2.1 Basic Sequence of Operations .....	5-4
5.2.2 Basic Sequence of Operation in Response to a Press on the Start Key .....	5-5
5.3 Various Control.....	5-5
5.3.1 Controlling the Scanner Drive System .....	5-5
5.3.1.1 Overview .....	5-5
5.3.1.2 Controlling the Scanner Motor.....	5-6
5.3.2 Enlargement/Reduction.....	5-7
5.3.2.1 Changing the Magnification in Main Scanning Direction .....	5-7
5.3.2.2 Changing the Magnification in Sub Scanning Direction .....	5-7
5.3.3 Controlling the Scanning Lamp .....	5-8
5.3.3.1 Overview .....	5-8
5.3.3.2 Scanning Lamp.....	5-8
5.3.3.3 Controlling the Activation.....	5-9
5.3.4 Detecting the Size of Originals .....	5-9
5.3.4.1 Overview .....	5-9
5.3.4.2 Points of Measurement Used for Original Size Identification .....	5-9
5.3.4.3 Overview of Operation.....	5-10
5.3.5 Dirt Sensor Control .....	5-12
5.3.5.1 Dust Detection in Stream Reading Mode.....	5-12
5.3.5.2 White Plate Dust Detection Control.....	5-13
5.3.6 Image Processing .....	5-14
5.3.6.1 Overview .....	5-14
5.3.6.2 CCD Drive .....	5-15
5.3.6.3 CCD Output Gain Correction, Offset Correction .....	5-15
5.3.6.4 CCD Output A/D Conversion .....	5-15
5.3.6.5 Outline of Shading Correction .....	5-15
5.3.6.6 Shading Adjustment .....	5-16
5.3.6.7 Shading Correction.....	5-16
5.4 Parts Replacement Procedure.....	5-17
5.4.1 CCD Unit .....	5-17
5.4.1.1 Before Removing the CCD Unit .....	5-17
5.4.1.2 Removing the CCD Unit.....	5-17
5.4.1.3 When Replacing the CCD Unit.....	5-17
5.4.2 Copyboard glass.....	5-18
5.4.2.1 Removing the Copyboard Glass.....	5-18
5.4.2.2 When Replacing the Copyboard Glass .....	5-18
5.4.3 Scanning Lamp .....	5-18
5.4.3.1 Before Removing the Scanning Lamp .....	5-18
5.4.3.2 Removing the Scanning Lamp .....	5-18
5.4.3.3 When Replacing the Scanning Lamp.....	5-19
5.4.4 Reader Controller PCB .....	5-19
5.4.4.1 Before Removing the Reader Controller PCB .....	5-19
5.4.4.2 Removing the Reader Controller PCB .....	5-19
5.4.4.3 After Replacing the Reader Controller PCB .....	5-20
5.4.5 Interface PCB.....	5-20
5.4.5.1 Before Removing the Interface PCB.....	5-20
5.4.5.2 Removing the Interface PCB .....	5-20

5.4.6 Memory PCB .....	5-21
5.4.6.1 Before Removing the Memory PCB.....	5-21
5.4.6.2 Removing the memory PCB .....	5-21
5.4.7 Inverter PCB .....	5-21
5.4.7.1 Before removing the inverter PCB .....	5-21
5.4.7.2 Removing the Inverter PCB.....	5-21
5.4.7.3 After Replacing the Inverter PCB.....	5-22
5.4.8 Scanner Motor.....	5-22
5.4.8.1 Before Removing the Scanner Motor .....	5-22
5.4.8.2 Removing the Scanner Motor.....	5-22
5.4.8.3 Mounting the Scanner Motor.....	5-23
5.4.9 ADF Open/Close Sensor.....	5-23
5.4.9.1 Before Removing the ADF Open/Close Sensor .....	5-23
5.4.9.2 Removing the ADF Open/Close Sensor .....	5-23
5.4.10 Scanner HP Sensor.....	5-23
5.4.10.1 Before Removing the Scanner HP Sensor .....	5-23
5.4.10.2 Removing the Mirror Base HP Sensor .....	5-23
5.4.11 Original Size Sensor .....	5-24
5.4.11.1 Before Removing the Original Size Sensor .....	5-24
5.4.11.2 Removing the original size sensor .....	5-24
5.4.12 Cooling Fan.....	5-25
5.4.12.1 Before Removing the Cooling Fan .....	5-25
5.4.12.2 Removing the Cooling Fan .....	5-25
5.4.13 Scanner Drive Cable .....	5-25
5.4.13.1 Outline .....	5-25
5.4.13.2 Before Removing the Scanner Drive Cable.....	5-25
5.4.13.3 Removing the Scanner Drive Cable.....	5-25
5.4.13.4 Fitting the Scanner Drive Cable.....	5-28
5.4.13.5 Adjusting the Position of the No. 1/No. 2 Mirror Base .....	5-28
5.4.14 Waste Toner Box Holder .....	5-29
5.4.14.1 Before Removing the Collecting Toner Bottle Holder.....	5-29
5.4.14.2 Removing the Collecting Toner Bottle Holder.....	5-29

## 5.1 Construction

### 5.1.1 Specifications, Controls, and Functions

iR5065 / iR 5055 / iR5075 / iR5075N / iR5065N / iR5055N

The specifications, controls, and functions of the machine's original exposure system are as follows:

T-5-1

Item	Description
Scanning lamp	YG xenon lamp
Original scanning	book mode: by moving the scanner
	ADF mode: by moving original
Original reading resolution	600 x 600 dpi (main scanning x sub scanning)
Halftone	256 gradations
Scanning position detection	by scanner HP sensor
lens	single-focal point, fixed type
Magnification	[1] in platen mode: 25% to 400%
	main scanning direction: image processing by controller block
	sub scanning direction: scanning speed variation (No. 1 mirror base; 100% or higher) in combination with image processing by reader block (50% or higher and lower than 100%)
	in combination with image processing in reader block and controller block (lower than 50%)
	[2] ADF mode: 25% to 200%
	main scanning direction: image processing in controller block
Scanner drive control	sub scanning direction: original movement speed variation (50% or higher); in combination with image processing in controller block (lower than 50%)
	No. 1/2 mirror base: control by pulse motor
Scanning lamp control	[1]activation control by pulse motor
	[2]error detection control
Original size detection	[1]book mode
	sub scanning direction: by reflection type sensor
	main scanning direction: by CCD
	[2] ADF mode
	main scanning direction: by slide guide in ADF
sub scanning direction: by photosensor in ADF	

### 5.1.2 Major Components

iR5065 / iR 5055 / iR5075 / iR5075N / iR5065N / iR5055N

The major components of the original exposure system are as follows:

T-5-2

Item	Notation	Description
Scanning lamp	LA1	xenon lamp (90,000 lx)
Scanner motor	M501	2-phase pulse motor (pulse control)
Reader Cooling fan	FM501	cools the reader block
ADF open/closed sensor 1	PS501	detects the state (open/closed) of the ADF; at 5 deg
Scanner HP sensor	PS502	detects scanner home position
ADF open/closed sensor 2	PS503	detects the state (open/closed) of the ADF (detects timing of size detection at 25 deg)
Original size sensor (AB)	---	detects the size in sub scanning direction (AB-configuration)
Original size sensor (inch)	---	detects size in sub scanning direction (inch)
Interface PCB	---	controls motor and fan, connects printer and ADF
Memory PCB	---	data delivery between main controller and reader controller/ADF
Mirror	---	No. 1, 2, 3 mirrors
Inverter PCB	---	drives the scanning lamp
CCD unit	---	collects image data, performs analog image processing

Item	Notation	Description
Reader controller PCB	---	controls the reader unit as a whole, performs digital image processing

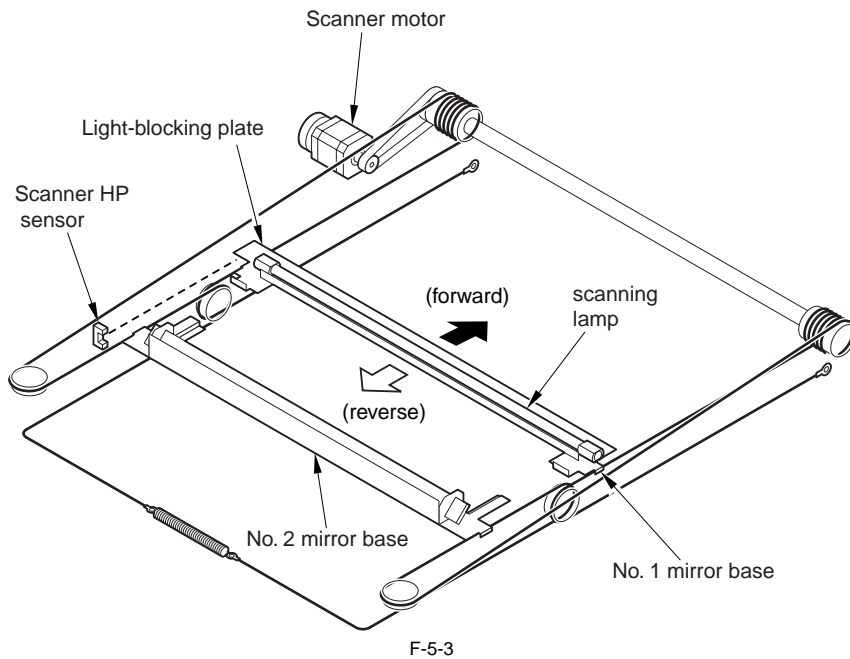
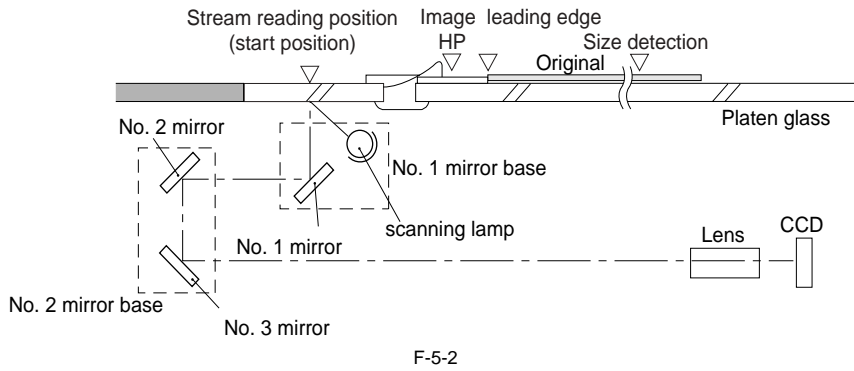
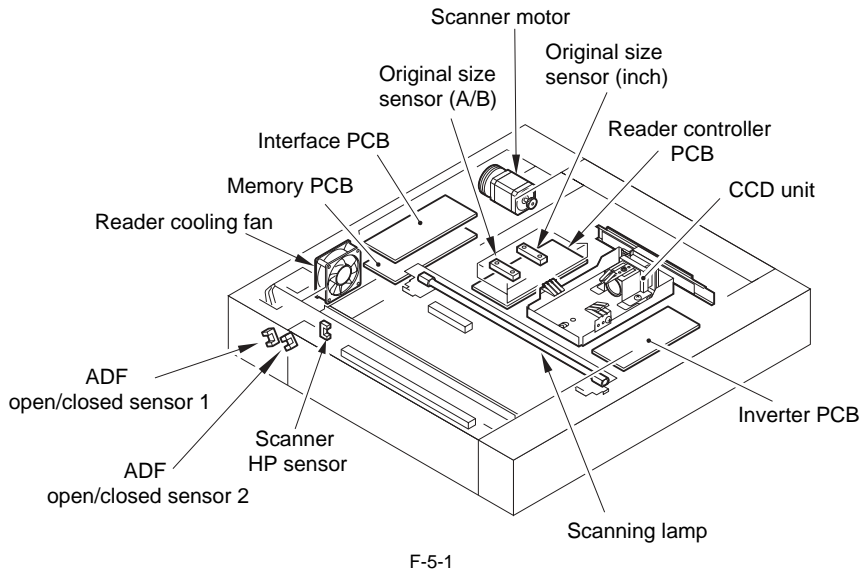

### 5.1.3 Construction of the Control System

iR5065 / iR 5055 / iR5075 / iR5075N / iR5065N / iR5055N

The construction of the control system of the machine's original exposure system is as follows:

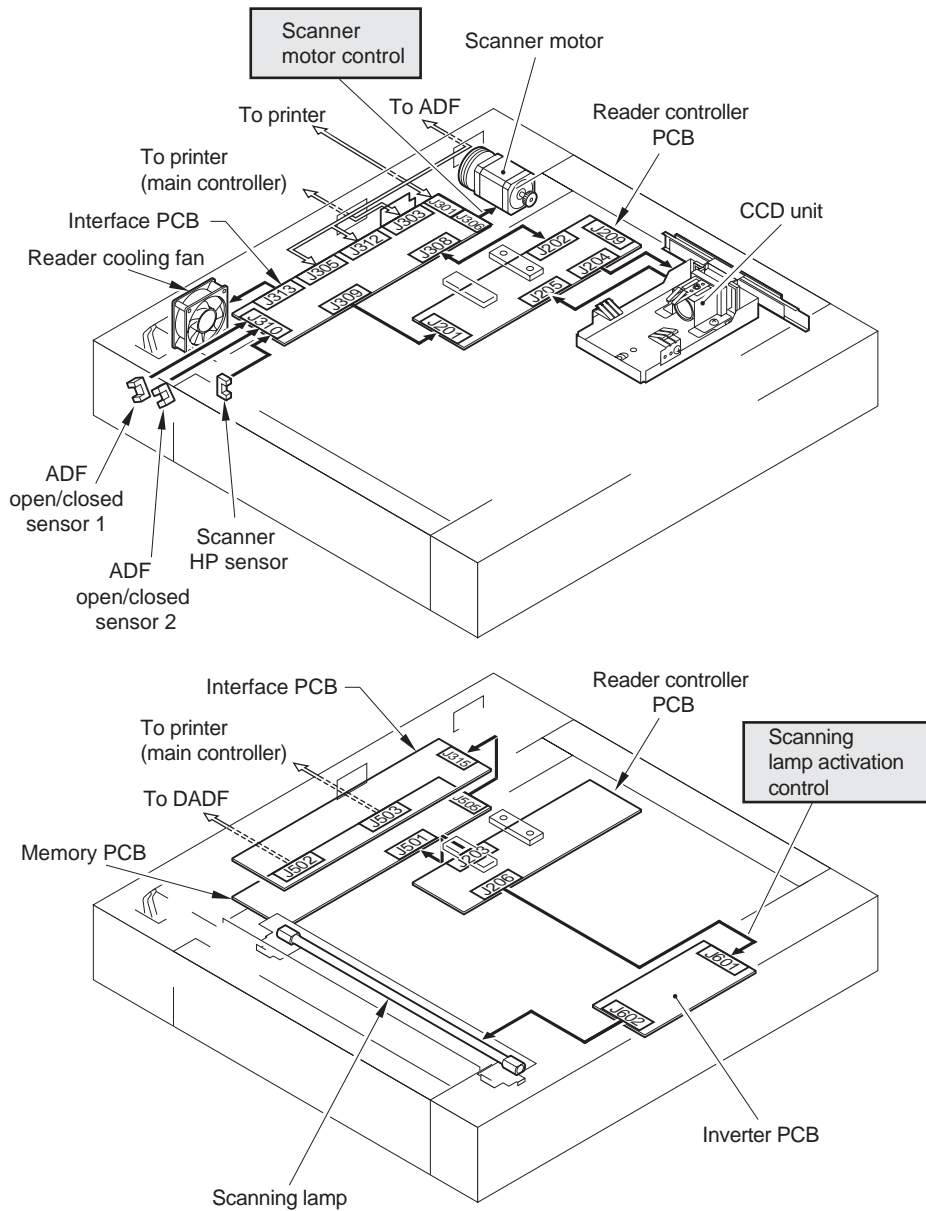

F-5-4

### 5.1.4 Reader Controller PCB

iR5065 / iR 5055 / iR5075 / iR5075N / iR5065N / iR5055N

The functional construction of the reader controller PCB is as follows:

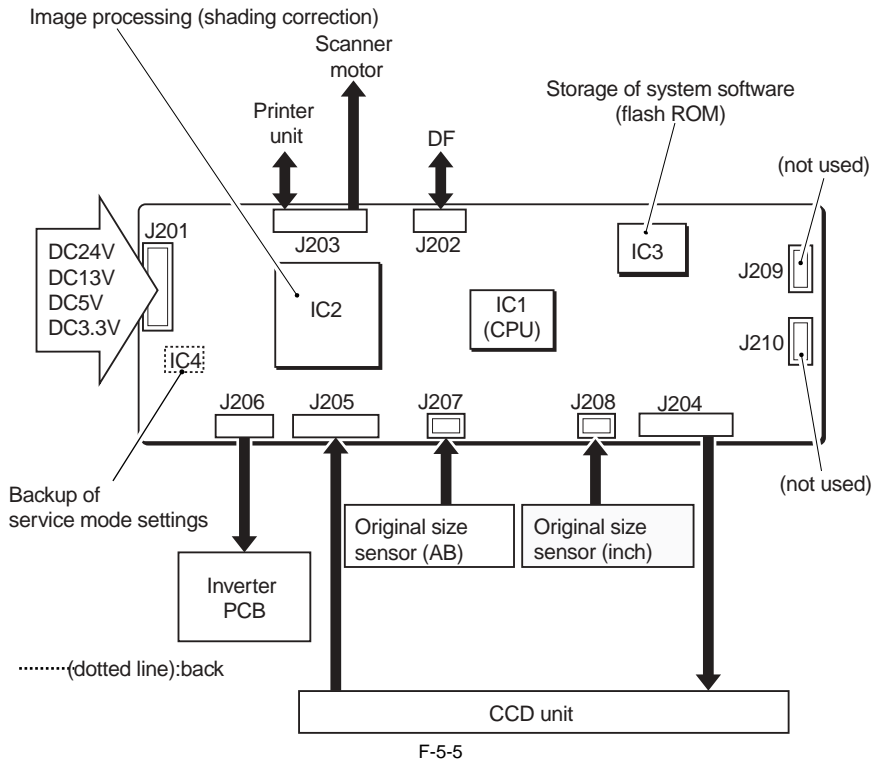

T-5-3

Jack	Description
J201	used for input of power from the machine (printer unit)
J202	used for communication with the ADF (sensor signal input, fan control, scanner motor control, controller)
J203	used for communication with the printer unit; connects to the scanner motor; used for communication with the ADF; used for input of image signals
J204	used for connection with the CCD unit.
J205	used for communication with the CCD unit.
J206	used for connection with the inverter PCB.
J207	used for connection with the original size sensor (AB).
J208	used for connection with the original size sensor (inch).
J209	not used
J210	not used.

T-5-4

IC	Description
IC1	CPU (holds boot program)
IC2	ASIC (holds RAM)
IC3	flash ROM (stores firmware)
IC4	EEPROM (backs up service mode settings)

## 5.2 Basic Sequence

### 5.2.1 Basic Sequence of Operations

iR5065 / iR 5055 / iR5075 / iR5075N / iR5065N / iR5055N

Basic Sequence of Operation at Power-On

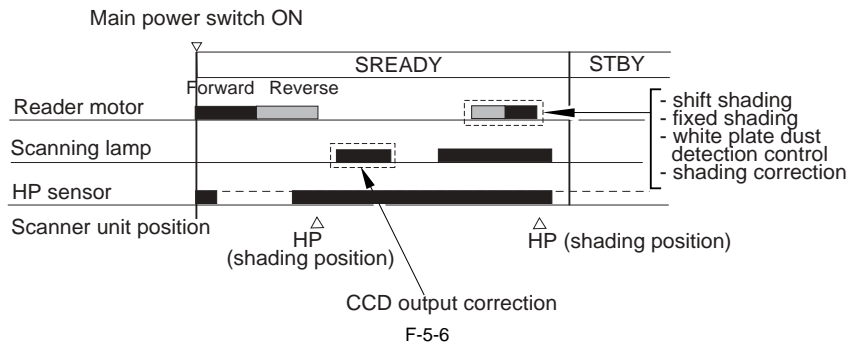

### 5.2.2 Basic Sequence of Operation in Response to a Press on the Start Key

iR5065 / iR 5055 / iR5075 / iR5075N / iR5065N / iR5055N

Basic Sequence of Operation in Response to a Press on the Start Key (book mode; 1 original)

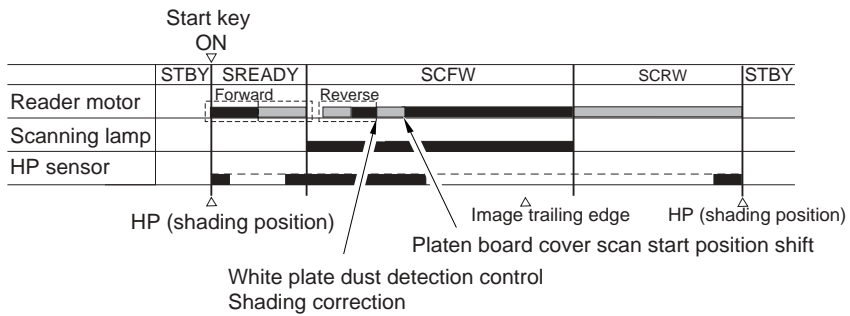

Basic Sequence of Operation in Response to a Press on the Start Key (ADF mode; 1 original)

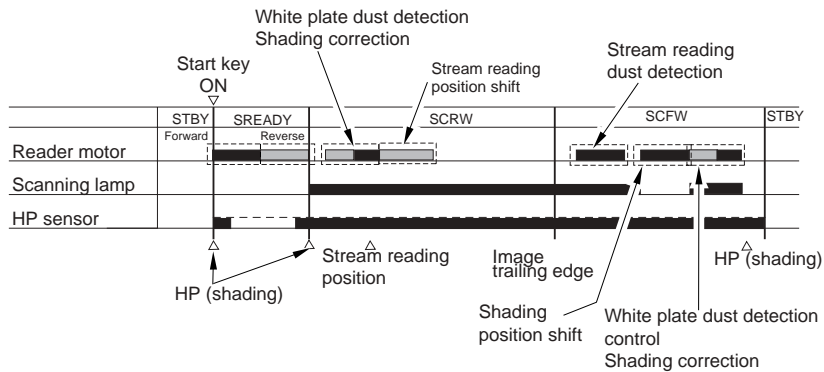

## 5.3 Various Control

### 5.3.1 Controlling the Scanner Drive System

#### 5.3.1.1 Overview

iR5065 / iR 5055 / iR5075 / iR5075N / iR5065N / iR5055N

The following shows the components associated with the scanner drive system:

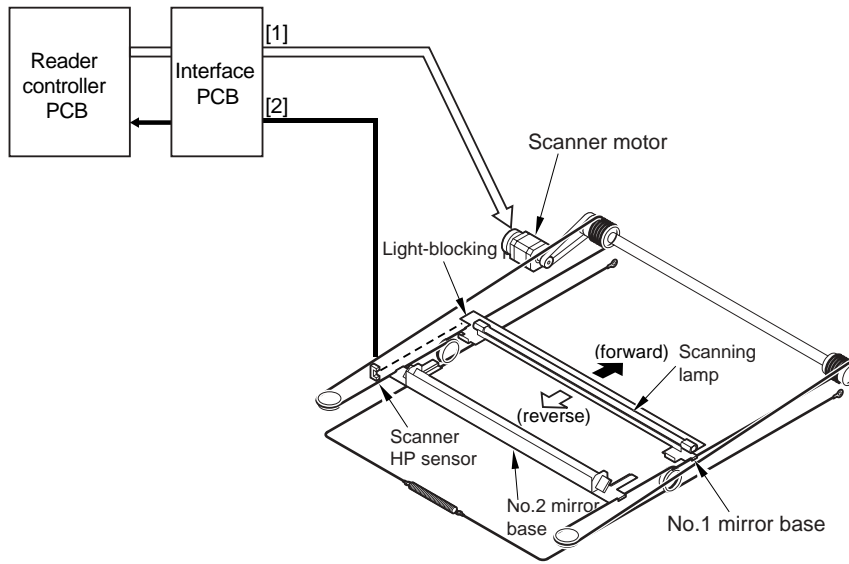

F-5-9

- [1] Scanner Motor M501 Drive Signal starts/stops the motor; controls the direction and speed of its rotation
- [2] Scanner HP Detection Signal detects the presence of the No. 1 mirror base at home position

### 5.3.1.2 Controlling the Scanner Motor

iR5065 / iR 5055 / iR5075 / iR5075N / iR5065N / iR5055N

The configuration of the system used to control the scanner motor is as follows; the motor driver on the interface PCB operates according to the signals from the CPU to start/stop the scanner motor and to control the direction and speed of its rotation

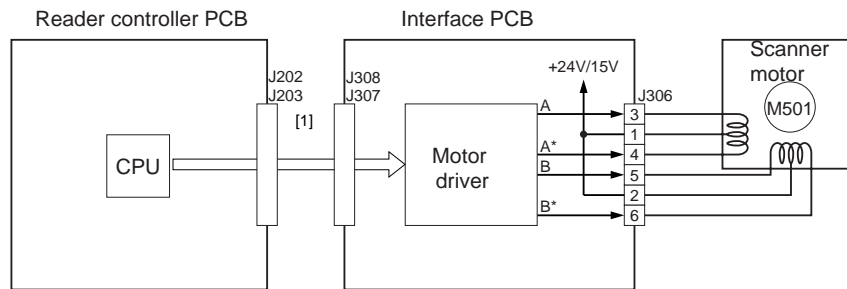

[1] Scanner motor control signal

F-5-10

#### 1. Reverse Movement After a Scan

After an image scan, the No. 1 mirror base is moved in reverse as far as the shading position at 234 mm/sec regardless of the selected magnification.

#### 2. Forward Movement During a Scan

During an image scan, the No. 1 mirror base is controlled at the speed indicated in the following figure; the No. 1 mirror base is moved forward at 325 mm/sec for 100% magnification.

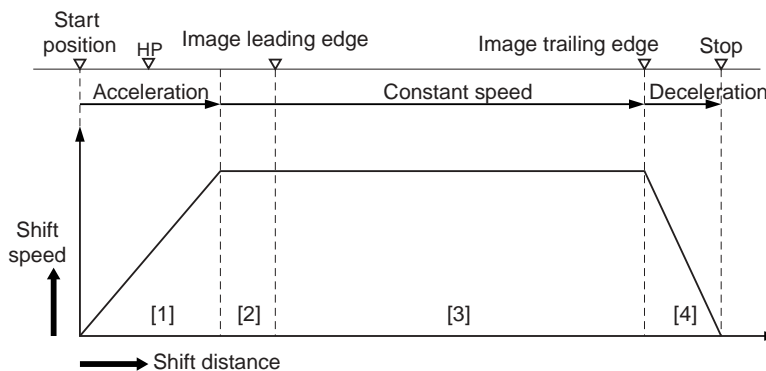

- [1] Acceleration interval: accelerates up to scan speed
- [2] Run-up interval: run-up margin used to ensure stable speed
- [3] Image read interval: segment over which images are read
- [4] Deceleration interval: at the image trailing edge, decelerates and stops as soon as possible

F-5-11



**ERROR CODE:****E202 (HP detection error)**

-0001: when the No. 1 mirror base is moving forward, it fails to reach the HP sensor within a specific period of time

-0002: when the No. 1 mirror base is moving in reverse, it fails to reach the HP sensor within a specific period of time

**SERVICE MODE:****COPIER>ADJUST>ADJ-XY>ADJ-X (scanner image leading edge position adjustment)**

Enter a value to adjust the image leading edge position.

settings range: 0 to 2970 (a change of '12' causes a shift of 1 mm)

**COPIER>AJST>ADJ-XY>ADJ-S (scanner home position)**

Do not change the setting.

**5.3.2 Enlargement/Reduction****5.3.2.1 Changing the Magnification in Main Scanning Direction**

iR5065 / iR 5055 / iR5075 / iR5075N / iR5065N / iR5055N

To change the magnification in main scanning direction (for both platen and ADF modes), the machine reads the image at 100% and applies appropriate image processing in the main controller block.

**5.3.2.2 Changing the Magnification in Sub Scanning Direction**

iR5065 / iR 5055 / iR5075 / iR5075N / iR5065N / iR5055N

To change the magnification in sub scanning direction, the machine changes the speed at which it moves the scanner/original.

For reduction, the machine also performs image data skipping (on main controller PCB and reader controller PCB).

[1] In platen mode, the machine changes the speed at which the mirror base is shifted for a ratio between 25% and 400%.

T-5-5

**Description**

25-49%	increases the mirror base speed. collects image data at the same speed as for a ratio between 100% and 196%. uses data skipping on the reader controller PCB (50%) uses data skipping on the main controller PCB (50%)
50-99%	increases the mirror base speed. e.g.: at 50%, reads images at twice the speed of 100%; also, uses data skipping on image data read at a ratio between 100% and 198% on the reader controller PCB (50%).
100%	325 mm/sec
101-200%	decreases the mirror base speed. e.g., at 200%, collects images at 1/2 the speed for 100%.
201-400%	decreases the mirror base speed. e.g., at 200%, collects images at 1/2 the speed for 100%.

The following shows the speeds at which the mirror base is moved:

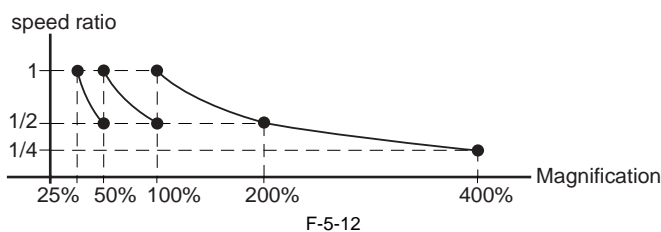

F-5-12

[2] In ADF mode, the machine changes the speed at which the original is moved for a ratio between 25% and 200%.

T-5-6

**Description**

25-49%	increases the speed used to move the original (as compared to 100%). collects image data at the same speed as for a ratio between 100% and 196%. uses data skipping on the main controller PCB (50%).
--------	---

Description	
50-99%	increases the speed at which the original is moved. e.g., at 50%, collects the image at twice the speed for 100%.
100%	325 mm/sec
101-200%	decreases the speed at which the original is moved. e.g., at 200%, collects image data at 1/2 the speed for 100%.

The following shows the speeds at which the original is moved:

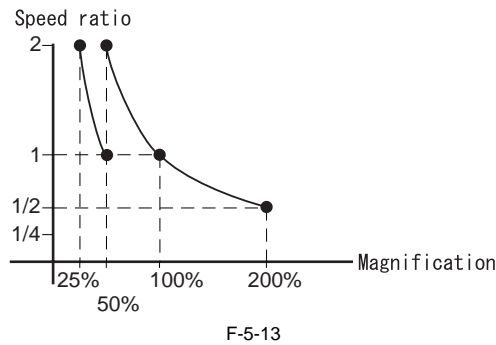

### 5.3.3 Controlling the Scanning Lamp

#### 5.3.3.1 Overview

iR5065 / iR 5055 / iR5075 / iR5075N / iR5065N / iR5055N

The following shows the items of control and the components of the control system associated with the activation of the scanning lamp:

##### 1. Controlling the Activation

The machine turns on or off the scanning lamp using the drive signal (XE-ON) generated by the CPU on the reader controller PCB. In response to the signal, the inverter PCB generates high-frequency high voltage in the activation motor circuit using the drive voltage (+24 V) supplied by the reader controller PCB, thus turning on the scanning lamp.

##### 2. Detecting an Error

The machine identifies an error in the intensity of light as an activation error occurring when the lamp is initially turned on (shading correction).

#### ERROR CODE:

##### E225

-0001: at time of shading, the detected intensity of light falls short of a specific level.

-0002: in ADF mode, the intensity of light between originals falls short of a specific level.

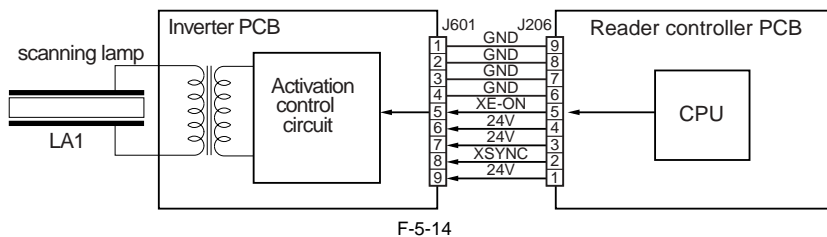

#### 5.3.3.2 Scanning Lamp

iR5065 / iR 5055 / iR5075 / iR5075N / iR5065N / iR5055N

The machine's scanning lamp is a xenon lamp consisting of a tube in which xenon gas is sealed. On the inner side of the glass tube are 2 electrodes running parallel to the tube axis, while the inner side is coated with fluorescent material. When high-frequency high voltage is applied to the electrodes, the gas inside the tube starts to discharge, thus illuminating the fluorescent material.

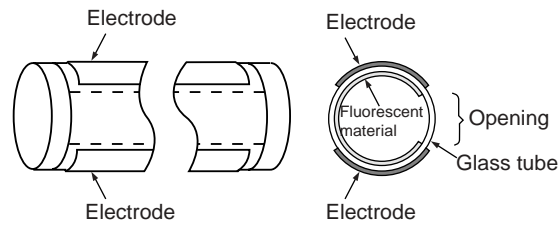

F-5-15

### 5.3.3.3 Controlling the Activation

iR5065 / iR 5055 / iR5075 / iR5075N / iR5065N / iR5055N

The machine turns on or off the scanning lamp using the drive signal (XE\_ON) from the CPU on the reader controller PCB. In response to the signal, the inverter PCB generates high-frequency high voltage in the activation control circuit using the drive voltage (+24 V) supplied by the reader controller PCB, thus turning on the xenon lamp.

### 5.3.4 Detecting the Size of Originals

#### 5.3.4.1 Overview

iR5065 / iR 5055 / iR5075 / iR5075N / iR5065N / iR5055N

The machine identifies the size of an original with reference to the combination of measurements taken of the light reflected at specific points of the CCD and the output of a reflection type sensor. It takes measurements at 2 points for individual sizes to ensure correct identification even in the event that the original is displaced while the ADF is being closed.

- for main scanning direction, by the CCD (for AB, 8 points; for inch-configuration, 6 points)
- for sub scanning direction, by a reflection type photosensor (for AB-configuration, 1 point; for inch-configuration, 1 point)

The machine identifies the size of an original as follows:

#### 1) External Light (main scanning direction only)

While keeping the scanning lamp off, the machine measures the CCD level at individual points of measurement in main scanning direction.

#### 2) Sensor Output Level

The machine turns on the scanning lamp, and measures the CCD level at individual points of measurement in main scanning direction. Also, the machine turns on the LED of the reflection type photosensor in sub scanning direction to measure the sensor output. It uses the combination of the measurement and the output to identify the size of the original in question.

### 5.3.4.2 Points of Measurement Used for Original Size Identification

iR5065 / iR 5055 / iR5075 / iR5075N / iR5065N / iR5055N

For main scanning direction, the machine moves the No. 1 mirror base to the point of CCD original detection to measure the CCD level at individual points of measurement. For sub scanning direction, the machine uses the outputs of original sensors 1 and 3.

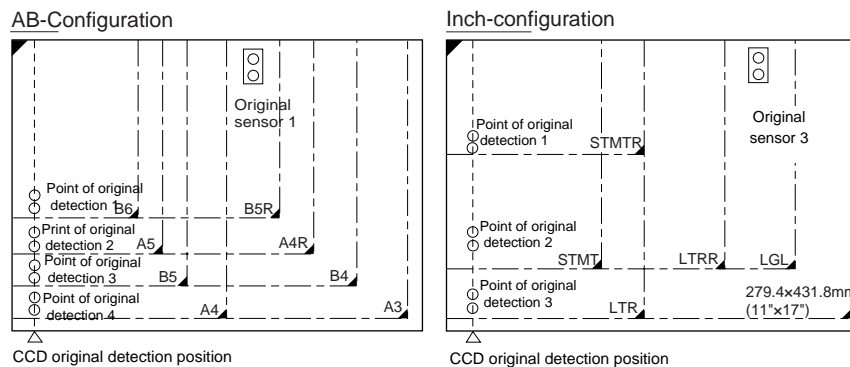

F-5-16

#### 1. Checking the Presence/Absence of an Original at 2 Points (individual points of detection)

For main scanning direction, the machine identifies the presence/absence of an original with reference to the CCD output at 2 points (nearest).

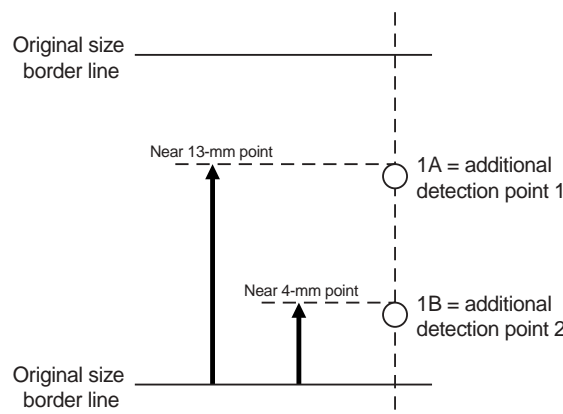

F-5-17

T-5-7

Result of movement		Result of identification
A	B	
no	no	original absent
yes	no	original present
no	yes	original present
yes	yes	original present

Note:  
 Change in the Signal in Response to ADF Open -> Closed  
 change present: no  
 other: yes  
 The OR argument is applied to the outputs at 2 points.

**2. Priority on the Presence of an Original at the Front**

If the machine detects the absence of an original at the rear in spite of detection of the presence at the front for main scanning direction, the machine will identify the size of the original upholding the result of detection at the front.

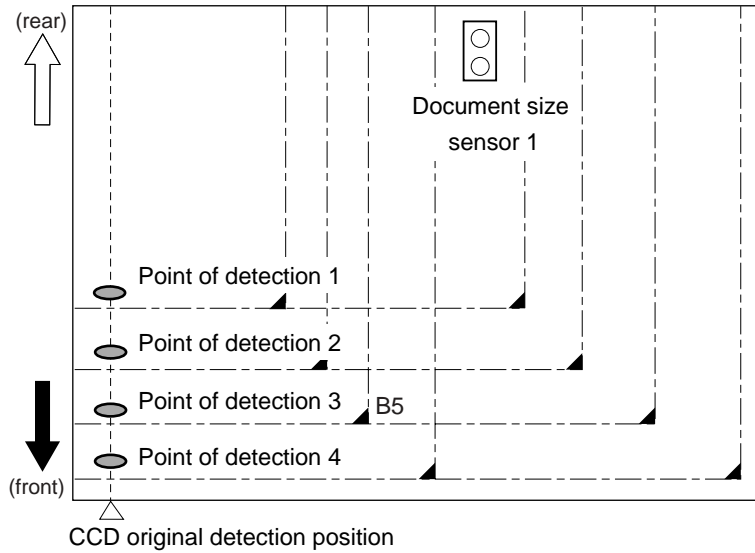

F-5-18

EX (B5 original)

T-5-8

Point of detection	Result of detection present/absent	Result of identification
1	present	present
2	absent	present
3	present	present
4	absent	absent
		B5

**5.3.4.3 Overview of Operation**

iR5065 / iR 5055 / iR5075 / iR5075N / iR5065N / iR5055N

**1. In a Wait State**

- No. 1 mirror base: at shading position
- scanning lamp: off
- original sensor

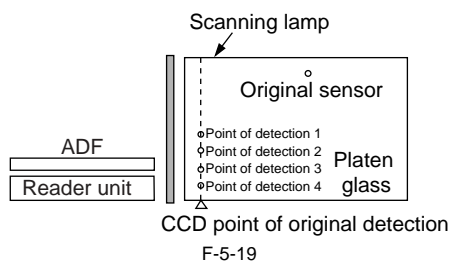

### 2. ADF Being Opened

No.1 mirror base: moves to a specific point of original detection  
 scanning lamp: off  
 original sensor: off

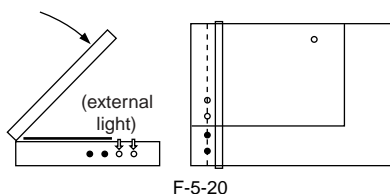

### 3. ADF Being Closed

No. 1 mirror base: at point of original detection  
 scanning lamp: off -> on  
 original sensor: original detection operation

- When the ADF is at 25 deg or lower, the external light within the width of any original is kept out of external light, thus causing the machine to assume the absence of an original at points of external light detection (external light search operation).

The ADF open/closed sensor 2 identifies the state as being "closed," and the machine starts original size detection.

Here, B5, B4, A4, and A3 are eliminated from the list of possible sizes.

- When the external light search is over, the machine turns on the xenon lamp for the main scanning lamp, and checks the CCD (4 points) for external light. For sub scanning direction, the machine starts to operate the original sensor.

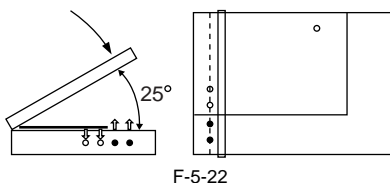
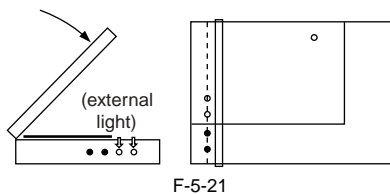

### 4. ADF Fully Closed (5 deg or less)

No. 1 mirror base: at point of original detection  
 scanning lamp: on  
 original sensor: original detection operation

The machine looks for a change in the output level of individual sensors for a period of 2 sec after the ADF open/closed sensor 1 has identified the current state as being "closed." The absence of a change in the level causes the machine to assume the presence of an original at the point in question.

The machine uses the combination of changes in the levels of 5 points to identify the size of the original in question.

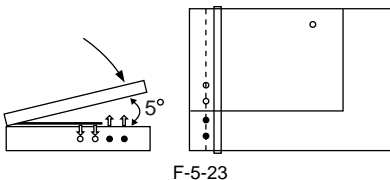

### 5. In a Wait State (for a press on the Start key)

No.1 mirror base: at point of original detection  
 scanning lamp: off  
 original sensor: off

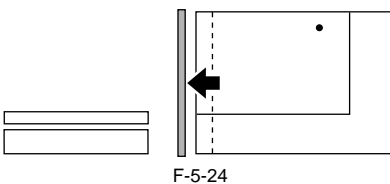

AB-Configuration								Inch-configuration									
Original size	CCD point of detection								Original size	CCD point of detection							
	1		2		3		4			1		2		3		sensor 3	
	A	B	A	B	A	B	A	B	sensor 1	A	B	A	B	A	B	sensor 3	
A3	○	○	○	○	○	○	○	○	○	○	○	○	○	○	○	○	
B4	○	○	○	○	○	○	●	●	○	○	○	○	○	○	○	○	
A4R	○	○	○	○	●	●	●	●	○	○	○	○	○	○	○	○	
A4	○	○	○	○	○	○	○	○	●	●	○	○	○	○	○	○	
B5	○	○	○	○	○	○	●	●	●	●	○	○	○	○	○	○	
B5R	○	○	●	●	●	●	●	●	○	○	○	○	○	○	○	○	
A5	○	○	○	○	●	●	●	●	●	●	○	○	○	○	○	○	
B6	○	○	●	●	●	●	●	●	●	●	○	○	○	○	○	○	
none	●	●	●	●	●	●	●	●	●	●	○	○	○	○	○	○	

○:change absent    ●:change present

F-5-25

**5.3.5 Dirt Sensor Control**

**5.3.5.1 Dust Detection in Stream Reading Mode**

iR5065 / iR 5055 / iR5075 / iR5075N / iR5065N / iR5055N

The machine uses the dust detection control mechanism to check for dust on the platen glass and the ADF platen roller, thus preventing reproduction of dust, if any, in output images.

**1. Timing of Control**

- at the end of a job
- between sheets (for every sheet)

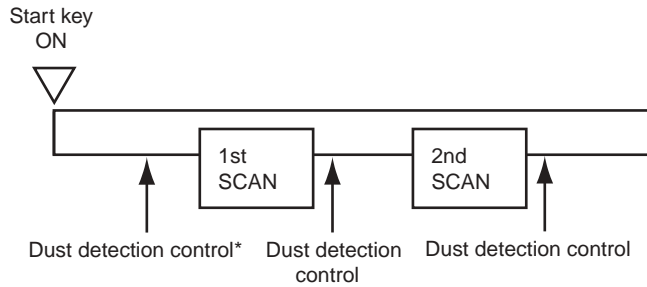

F-5-26

\*Executed only if dust has been detected at all points (A, B, C, D, E) during the previous job. In such a case, the machine will use the point subjected to least dust, and executes correction before starting a read operation.

**2. Particulars of Control**

- At the End of a Job (changing the stream reading dust read position)

The machine measures the light reflected by the surface of the platen roller, and detects the presence/absence of dust with reference to its intensity. If the presence of dust is detected, the machine moves to the next point (5 points max.; A -> B -> C -> D -> E).

The machine uses the first point at which the absence of dust is detected as the read point for the next job.

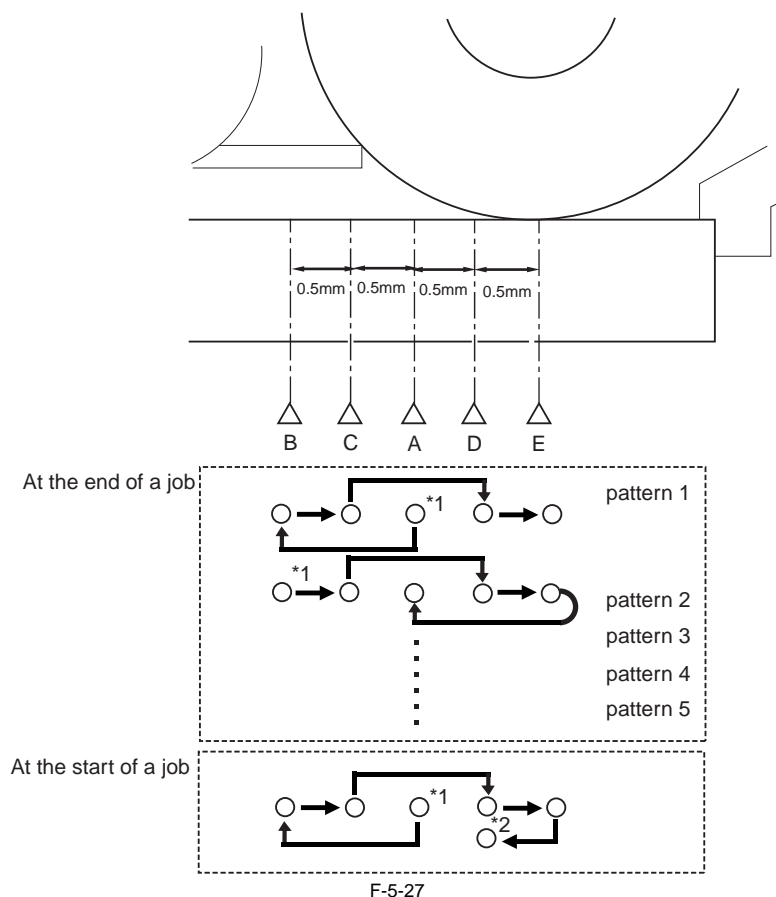

F-5-27

If dust is detected at all 5 points (A, B, C, D, E), the machine will issue an alert in response to the placement of an original in the ADF, thus promoting the user to clean the points.

**Alert Message:**

The machine may read the dust, which may show as lines in the output image. Clean the narrow segment of glass indicated in the drawing with a soft cloth moistened with water (and well wrung).

Press the Close button to reset the alert.

At the start of a job, the machine executes dust detection once again, and will use a point with little or no dust as the read point.

\*1: read point at the end of the previous job.

\*2: point with little or no dust.

T-5-9

A	read reference point (1.0 mm to the left from the center of the platen roller)
B	point 1.0 mm to the left from the reference point
C	point 0.5 mm to the left from the reference point
D	point 0.5 mm to the right for the reference point
E	point 1.0 mm to the right from the reference point (center of platen roller)

**- Between Sheets (dust correction)**

The machine does not move the scanning lamp on account of dust detection.

If dust is detected between sheets, the machine corrects the fact with reference to the pixels on both sides of the area of dust.

**SERVICE MODE:**

**COPIER>OPTION>BODY>DFDST-L1 (level 1)**

use it to adjust dust detection level between sheets

**COPIER>OPTION>BODY>DFDST-L2 (level 2)**

use it to adjust dust detection level at the end of a job

**5.3.5.2 White Plate Dust Detection Control**

iR5065 / iR 5055 / iR5075 / iR5075N / iR5065N / iR5055N

The white plate can collect stray dust inside the reader unit, causing lines in images, and the machine is equipped with a mechanism to check for dust on the plate and correct it to limit its effects on output images.

**1. Timing of Control**

(1) Before a Job

- (a) white plate dust detection
- (b) white plate dust correction

(2) After a Job

- (a) white plate dust detection
- (b) white plate dust correction

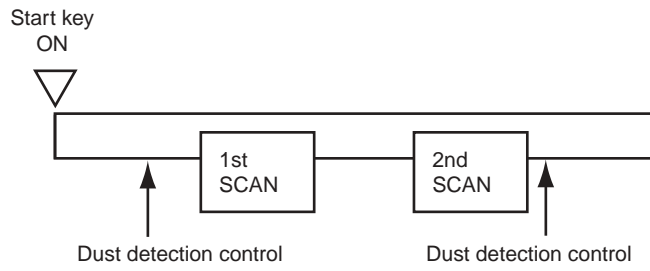

F-5-28

**2. Particulars of Control**

**- White Plate Dust Detection**

The machine compares the data on the light reflected by the white plate at time of fixed shading and shift shading to check for dust on the white plate while at the same time identifying the coordinates and width of the area of dust.

**- White Plate Dust Correction**

If the machine detects the presence of dust, it corrects the shading correction coefficient of the area of dust by means of a correction coefficient used for both sides of the area with dust, thus limiting the effects of the dust.

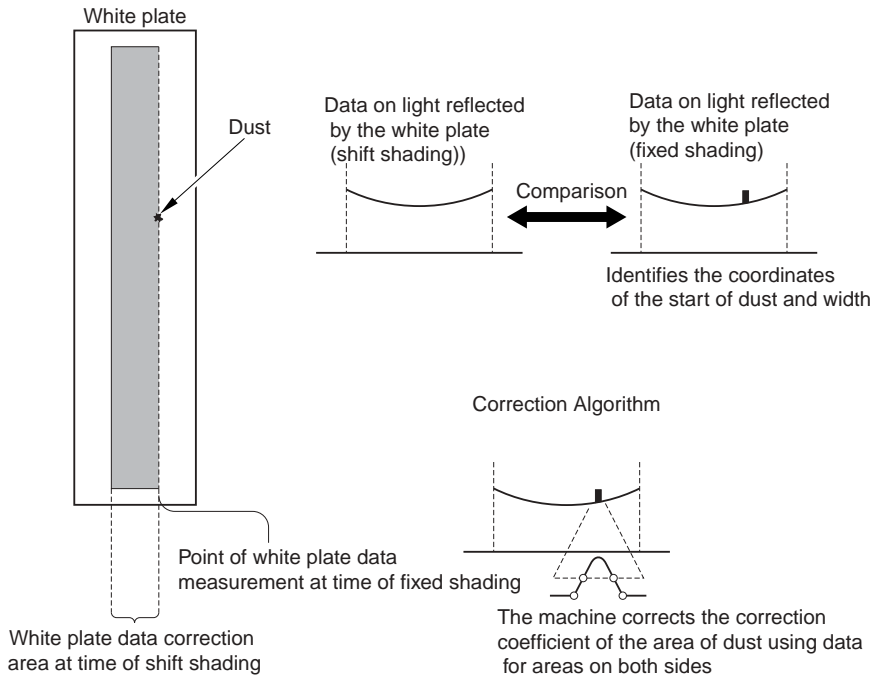

F-5-29

**5.3.6 Image Processing**

**5.3.6.1 Overview**

iR5065 / iR 5055 / iR5075 / iR5075N / iR5065N / iR5055N

The PCBs used in the image processing system have the following functions:

CDD/AP PCB: CCD drive, analog image processing, A/D conversion

Reader controller PCB: shading correction

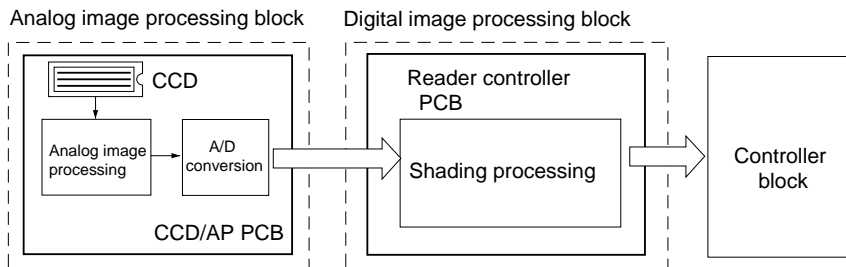

F-5-30

**1. Analog Image processing**

- CCD drive
- CCD output gain correction, offset correction
- CCD output A/D conversion



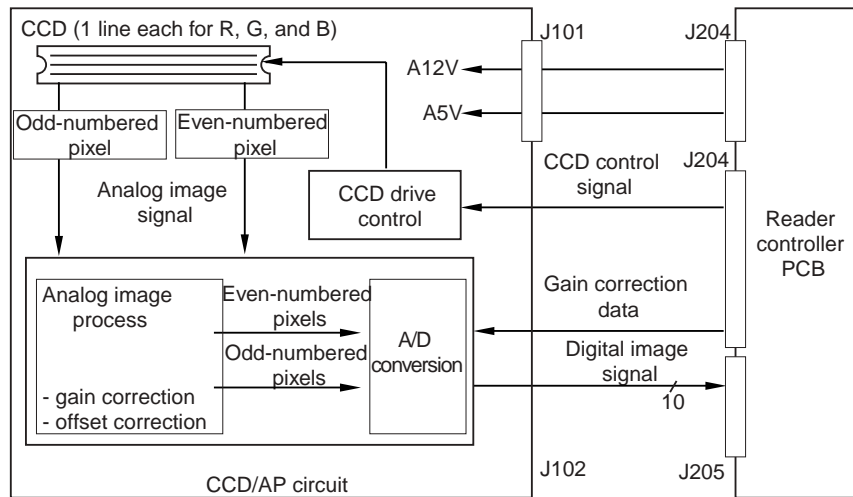

F-5-31

**2. Digital Image Processing**  
- shading correction

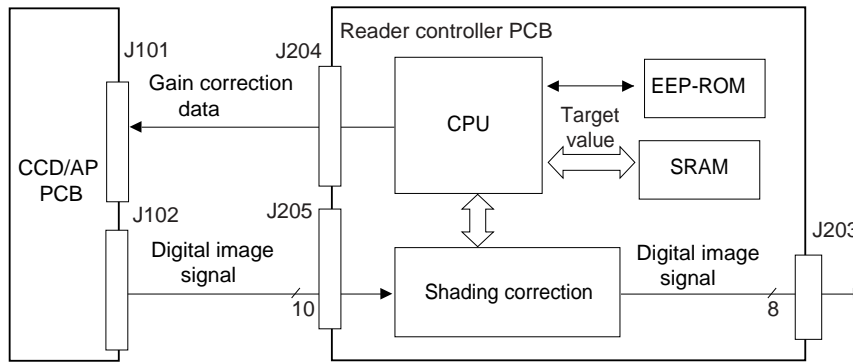

F-5-32

**5.3.6.2 CCD Drive**

iR5065 / iR 5055 / iR5075 / iR5075N / iR5065N / iR5055N

**1. CCD**

The CCD used in the machine is a 1-line linear image sensor.  
- Number of pixels: 7450  
- Size of a pixel: 4.7 x 4.7 μm

**2. CCD Drive**

The signals converted by the light-receiving block are sent out in 2 analog video signal channels (even-numbered pixels, odd-numbered pixels).

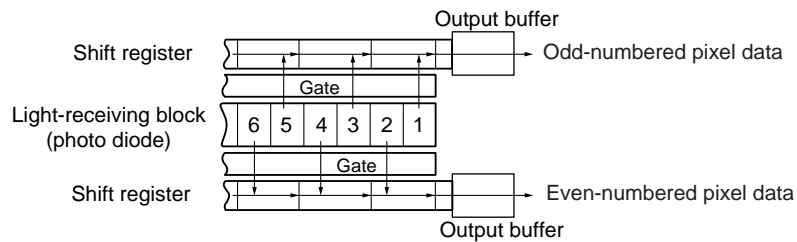

F-5-33

**5.3.6.3 CCD Output Gain Correction, Offset Correction**

iR5065 / iR 5055 / iR5075 / iR5075N / iR5065N / iR5055N

The machine processes the analog video signals from the CCD so that the rate of their amplitude is a specific level. The machine also makes sure that the output voltage in the absence of incident light is of a specific level (offset correction).

**5.3.6.4 CCD Output A/D Conversion**

iR5065 / iR 5055 / iR5075 / iR5075N / iR5065N / iR5055N

The odd-numbered and even-numbered pixel analog video signals after correction are further converted into 10-bit digital signals representing specific pixel voltage levels by the A/D converter.

**5.3.6.5 Outline of Shading Correction**

iR5065 / iR 5055 / iR5075 / iR5075N / iR5065N / iR5055N

The machine executes shading correction so that the CCD output will be even when the density of the original is even.

The output of the CCD may not necessarily be even because of the following factors even if the density of the original is perfectly even:

- (1) variation in the sensitivity of the individual pixels of the CCD
- (2) difference in the degree of light passing through the center of the lens and through its edge
- (3) difference in the intensity of light between the center and ends of the scanning lamp
- (4) deterioration of the scanning lamp

The machine executes shading correction to make up for the variation in the output of the CCD.

Shading correction may be shading adjustment executed to determine a service mode target value or shading correction executed for every job.

### 5.3.6.6 Shading Adjustment

iR5065 / iR 5055 / iR5075 / iR5075N / iR5065N / iR5055N

In shading adjustment, the machine measures the density of a white sheet of paper and the standard white plate, and stores the measurements in memory. The machine then computes these measurements for use as the target value for shading correction. Shading adjustment is executed at time of machine installation or scanning lamp replacement, or when a change has occurred in the intensity of light over time.

#### Service Mode:

COPIER>FUNCTION>CCD>CCD-ADJ

### 5.3.6.7 Shading Correction

iR5065 / iR 5055 / iR5075 / iR5075N / iR5065N / iR5055N

The machine executes shading correction for every scan of an original.

The machine shines the light of the scanning lamp against the standard white plate, and measures the light reflected by the plate; it then uses the analog image processing block of the CCD/AP PCB to turn the measurements into digital data, which will be sent to the shading correction circuit of the reader controller PCB in the form of a shading coefficient.

In the shading correction circuit, the shading coefficient is compared against the target value stored in memory, and the machine uses the differences as the shading correction value.

The shading correction value is used to make up for the variation among individual pixels of the CCD occurring at each scan, thus evening out the image density level.

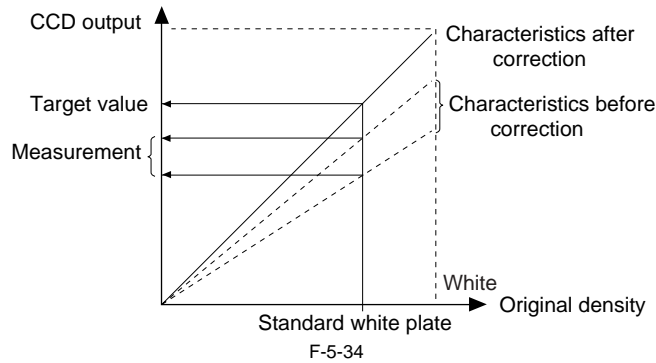

## 5.4 Parts Replacement Procedure

### 5.4.1 CCD Unit

#### 5.4.1.1 Before Removing the CCD Unit

iR5065 / iR 5055 / iR5075 / iR5075N / iR5065N / iR5055N

- 1) Detach the copyboard glass. (page 5-18) Reference [Removing the Copyboard Glass]

#### 5.4.1.2 Removing the CCD Unit

iR5065 / iR 5055 / iR5075 / iR5075N / iR5065N / iR5055N

- 1) Detach the CCD unit cover [2].  
- 9 Screw [1]

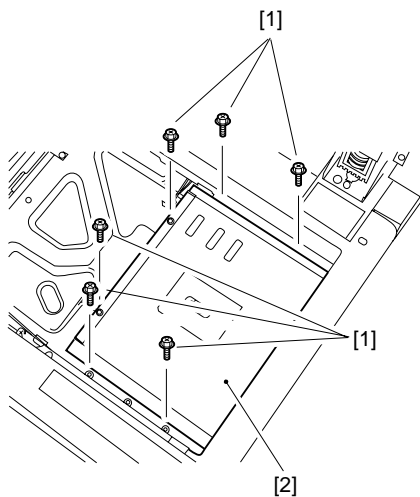

F-5-35

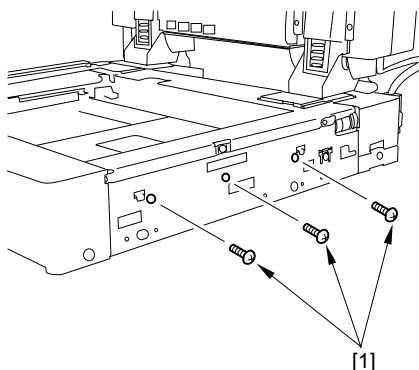

F-5-36

- 2) Slide the original size detection unit [2].  
- 3 Screw [1]

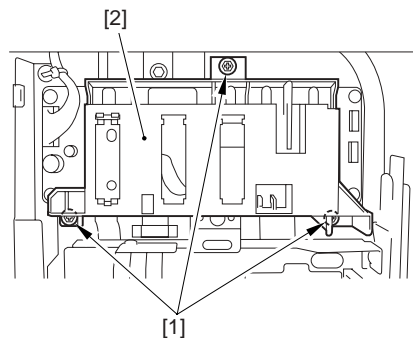

F-5-37

- 3) Detach the original size sensor unit [2].  
- 1 connector [1]

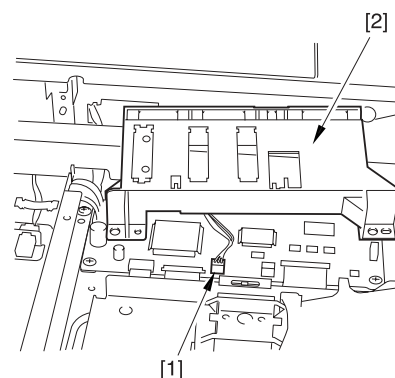

F-5-38

- 4) Detach the CCD unit [4] of the reader controller PCB.  
- 2 Flat cable [1]  
- 2 Screw [2]  
- 2 Leaf spring [3]

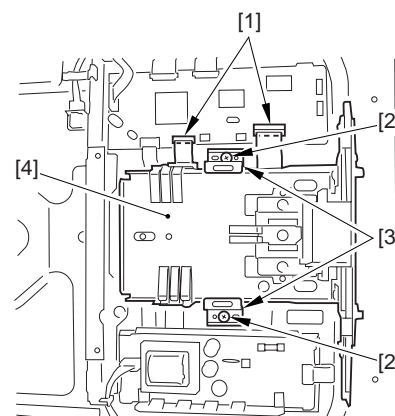

F-5-39



**How to disconnect the flat cable**  
Slide the locking lever [1] in the direction of the arrow to release; then, disconnect the flat cable [2].

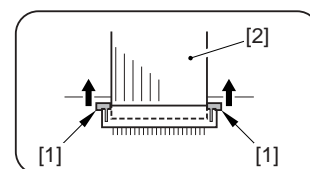

F-5-40

#### 5.4.1.3 When Replacing the CCD Unit

iR5065 / iR 5055 / iR5075 / iR5075N / iR5065N / iR5055N

Perform the following steps after replacing the CCD unit.

- 1) Enter the correction values to be described on the label included in the CCD unit (the 2 following items) in the service mode.  
- COPIER > ADJUST > CCD > DFCH2G2  
- COPIER > ADJUST > CCD > DFCH2G10
- 2) Transcribe the above correction values to the service label at the back of the front cover of the host machine.
- 3) Execute the following in the service mode.  
3-1) White plate data adjustment (COPIER > FUNCTION > CCD > CCD-ADJ)

3-2) ADF white level adjustment (COPIER > FUNCTION > CCD > DF-WLVL1/2)



Be sure to perform white plate data adjustment before performing ADF white level plate.

### 5.4.2 Copyboard glass

#### 5.4.2.1 Removing the Copyboard Glass

iR5065 / iR 5055 / iR5075 / iR5075N / iR5065N / iR5055N

- 1) Open the ADF.
- 2) Remove the 2 screws [1], and detach the right glass retainer [2]; then, detach the copyboard glass [3].

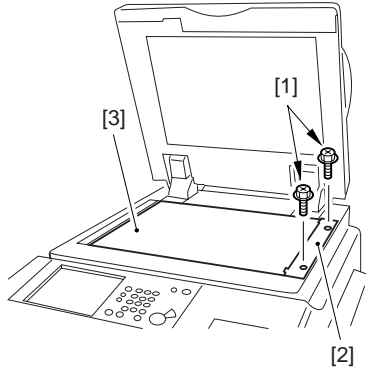

F-5-41



- When detaching the copyboard glass, take care not to touch the white plate attached to its back. Soiling can cause lines in the image. If soiled, clean it using lint-free paper moistened with alcohol.
- Take care not to deform the sponge [2] attached to the right glass retainer [1].

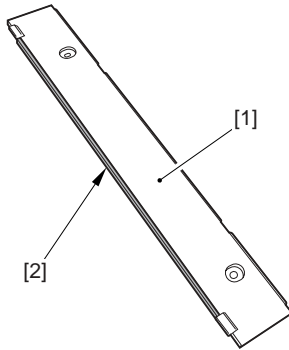

F-5-42

#### 5.4.2.2 When Replacing the Copyboard Glass

iR5065 / iR 5055 / iR5075 / iR5075N / iR5065N / iR5055N

Execute the following in the service mode:

- 1) White plate data adjustment (COPIER > FUNCTION > CCD > CCD-ADJ)
- 2) ADF white level adjustment (COPIER > FUNCTION > CCD > DF-WLVL1/2)



Be sure to perform white plate data adjustment before performing ADF white level adjustment.

### 5.4.3 Scanning Lamp

#### 5.4.3.1 Before Removing the Scanning Lamp

iR5065 / iR 5055 / iR5075 / iR5075N / iR5065N / iR5055N

- 1) Detach the copyboard glass. (page 5-18) Reference[Removing the Copyboard Glass]
- 2) Detach the right cover (upper). (page 10-12) Reference[Removing the

- Right Cover (Upper)]
- 3) Detach the reader right cover. (page 10-17) Reference[Removing the Reader Right Cover]
- 4) Detach the left cover (upper). (page 10-12) Reference[Removing the Left Cover (Upper)]
- 5) Detach the reader left cover. (page 10-17) Reference[Removing the Reader Left Cover]
- 6) Detach the reader front cover. (page 10-17) Reference[Detaching the Reader Front Cover]
- 7) Detach the reader rear cover. (page 10-18) Reference[Detaching the Reader Rear Cover]

#### 5.4.3.2 Removing the Scanning Lamp

iR5065 / iR 5055 / iR5075 / iR5075N / iR5065N / iR5055N

- 1) Detach the CCD unit cover [2].  
- 9 Screw [1]

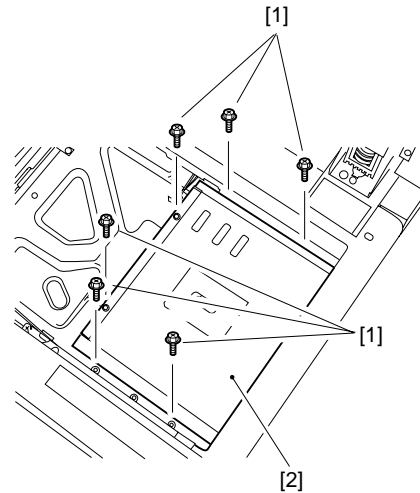

F-5-43

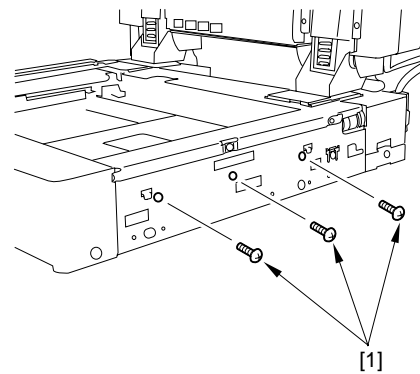

F-5-44

- 2) Free the cable [2] from the cable guide [3].  
- 1 Connector [1]  
- 1 Reuse band [4]
- 3) Open the ferrite core [5] to detach.

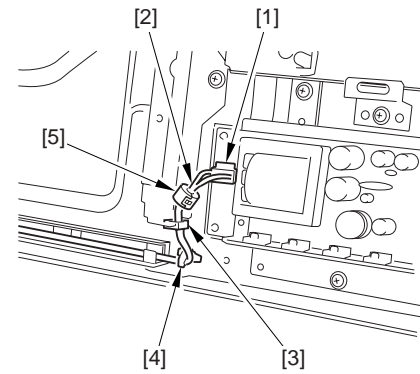

F-5-45



When replacing the scanning lamp, be sure to fit the removed ferrite core to

the new lamp.

- 4) Slide the No. 1 mirror base [1] to the right so that it matched against the cut-off [2] of the frame.



When detaching the No. 1 mirror base, be sure to hold it by the bend [A] on the mirror stay.

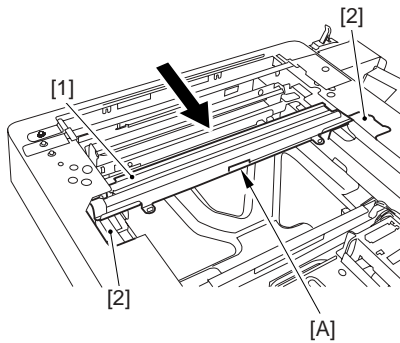

F-5-46

- 5) Detach the scanning lamp [2].  
- 2 Screw [1]

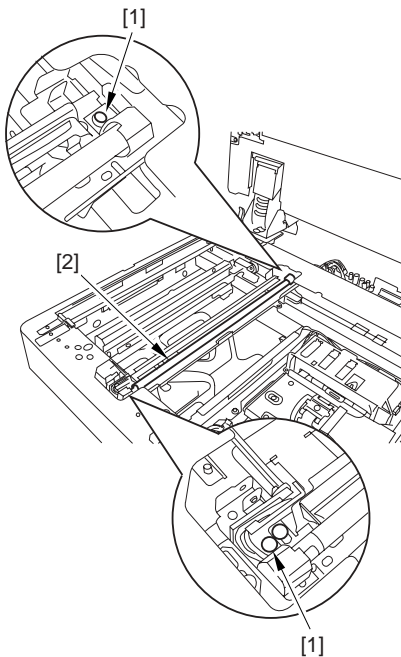

F-5-47

### 5.4.3.3 When Replacing the Scanning Lamp

iR5065 / iR 5055 / iR5075 / iR5075N / iR5065N / iR5055N

Execute the following in the service mode:

- 1) White plate data adjustment (COPIER > FUNCTION > CCD > CCD-ADJ)
- 2) ADF white level adjustment (COPIER > FUNCTION > CCD > DF-WLVL1/2)



Be sure to perform white plate data adjustment before performing ADF white level adjustment.

## 5.4.4 Reader Controller PCB

### 5.4.4.1 Before Removing the Reader Controller PCB

iR5065 / iR 5055 / iR5075 / iR5075N / iR5065N / iR5055N

- 1) Detach the copyboard glass. (page 5-18) Reference [Removing the Copyboard Glass]

### 5.4.4.2 Removing the Reader Controller PCB

iR5065 / iR 5055 / iR5075 / iR5075N / iR5065N / iR5055N

- 1) Detach the CCD unit cover [2].  
- 9 Screw [1]

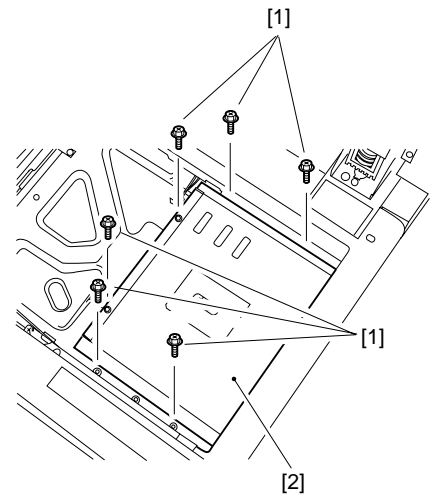

F-5-48

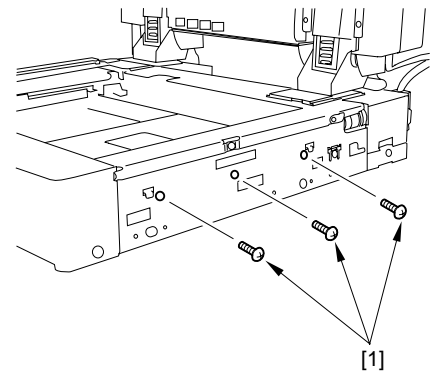

F-5-49

- 2) Slide the original size detection unit [2].  
- 3 Screw [1]

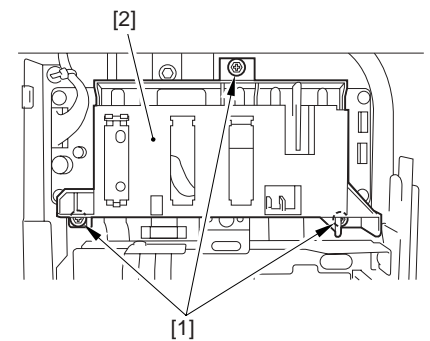

F-5-50

- 3) Detach the original size sensor unit [2].  
- 1 Connector [1]

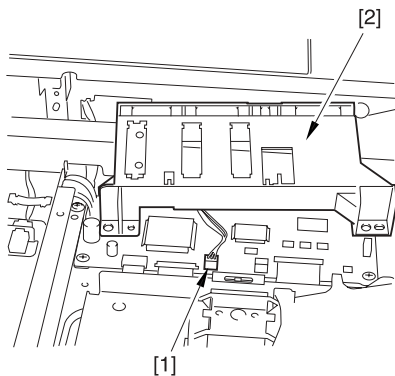

F-5-51

4) Detach the reader controller PCB [4].

- 5 Flat cable [1]
- 1 Connector [2]
- 4 Screw [3]

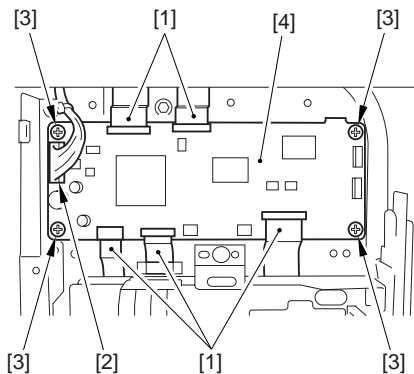

F-5-52

**⚠ How to disconnect the flat cable**

Slide the locking lever [1] in the direction of the arrow to release; then, disconnect the flat cable [2].

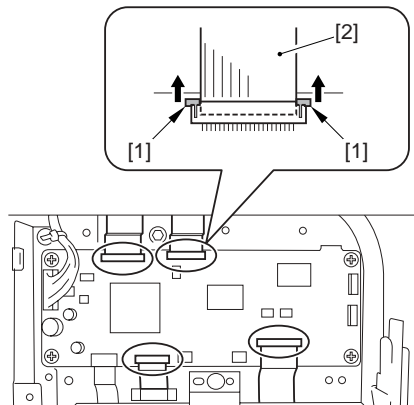

F-5-53

**5.4.4.3 After Replacing the Reader Controller PCB**

iR5065 / iR 5055 / iR5075 / iR5075N / iR5065N / iR5055N



Be sure to generate the latest P-PRINT printout before replacing the reader controller PCB.

- If you are initializing the RAM on the reader controller without replacing the PCB

Using the SST, upload the backup data of R-CON; initialize the RAM, and then download the data, thus eliminating the need for the following.

- 1) Using the SST, download the latest system software (R-CON).
- 2) Make the following selections in the service mode: COPIER > FUNCTION > CLEAR > R-CON. Then, press the OK key to execute RAM initialization. Thereafter, turn off and then back on the main power.
- 3) Enter the appropriate settings for the following items in the service mode:
  - a. setting indicated on the service label (found behind the reader unit front

cover)

- a-1. image read start position adjustment (X direction; in fixed reading mode)  
COPIER>ADJUST>ADJ-XY>ADJ-X
- a-2 image read start position adjustment (Y direction; in fixed reading mode)  
COPIER>ADJUST>ADJ-XY>ADJ-Y
- a-3 shading position adjustment (in fixed reading mode)  
COPIER>ADJUST>ADJ-XY>ADJ-S
- a-4 feeder mode main scanning position adjustment  
COPIER>ADJUST>ADJ-XY>ADJ-Y-DF
- a-5 ADF stream reading CCD reading position  
COPIER>ADJUST>ADJ-XY>STRD-POS
- a-6 density manipulating value adjustment  
COPIER>ADJUST>CCD>DFCH-G2  
COPIER>ADJUST>CCD>DFCH-G10  
(After inputs it, execute COPIER>FUNCTION>DF-LNR)



The machine retains ADF-related service data in the RAM of its reader controller.

ADF adjustment is necessary whenever you have replaced the reader controller or initialized the RAM.

- b. original stop position adjustment (X direction) (stream reading)  
FEEDER>ADJUST>DOCST
- c. original feed speed (magnification) adjustment  
FEEDER>ADJUST>LA-SPEED

4) Make adjustments using the following service mode items:

- a. ADF sensor sensitivity adjustment  
FEEDER>FUNCTION>SENS-INT
- b. tray width adjustment  
FEEDER>FUNCTION>TRY-A4  
FEEDER>FUNCTION>TRY-A5R  
FEEDER>FUNCTION>TRY-LTR  
FEEDER>FUNCTION>TRY-LTRR
- c. white plate data adjustment  
COPIER>FUNCTION>CCD>CCD-ADJ
- d. ADF white level adjustment  
COPIER>FUNCTION>CCD>DF-WLVL1  
COPIER>FUNCTION>CCD>DF-WLVL2



Be sure to perform white plate data adjustment before performing ADF white level adjustment.

After having made the foregoing adjustments, put the P-PRINT printout in the service book case, replacing the previous P-PRINT printout.

**5.4.5 Interface PCB**

**5.4.5.1 Before Removing the Interface PCB**

iR5065 / iR 5055 / iR5075 / iR5075N / iR5065N / iR5055N

1) Detach the reader rear cover. (page 10-18)Reference[Detaching the Reader Rear Cover]

**5.4.5.2 Removing the Interface PCB**

iR5065 / iR 5055 / iR5075 / iR5075N / iR5065N / iR5055N

- 1) Detach the interface PCB mount [4].
  - 9 Connector [1]
  - 1 Flat cable [2]
  - 9 Screw [3]

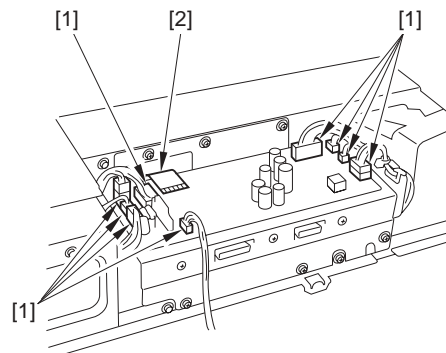

F-5-54

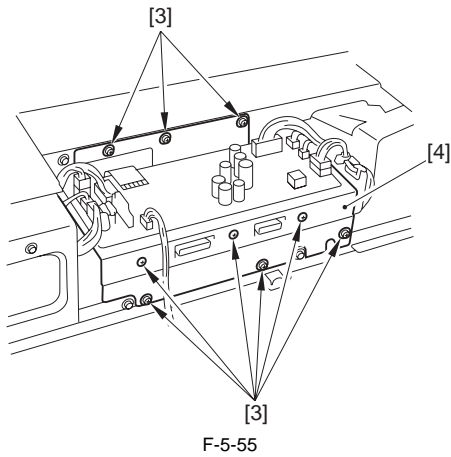

F-5-55

**⚠ How to disconnect the flat cable**  
Slide the locking lever [1] in the direction of the arrow; then, disconnect the flat cable [2].

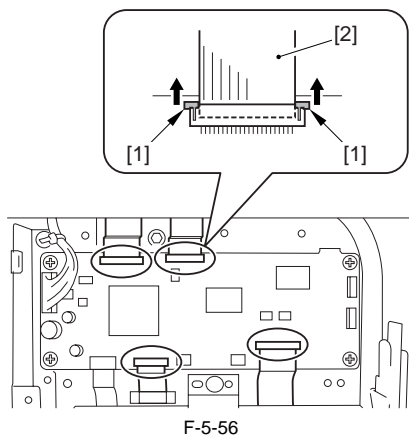

F-5-56

3) Detach the interface PCB [2].  
- 6 Screw [1]

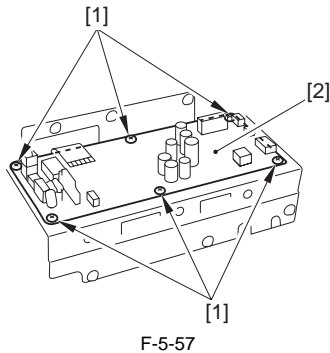

F-5-57

### 5.4.6 Memory PCB

#### 5.4.6.1 Before Removing the Memory PCB

iR5065 / iR 5055 / iR5075 / iR5075N / iR5065N / iR5055N

- 1) Detach the reader rear cover. (page 10-18)Reference[Detaching the Reader Rear Cover]
- 2) Detach the interface PCB. (page 5-20)Reference[Removing the Interface PCB]

#### 5.4.6.2 Removing the memory PCB

iR5065 / iR 5055 / iR5075 / iR5075N / iR5065N / iR5055N

- 1) Detach the memory PCB mount [4].  
- 1 Connector [1]  
- 1 Flat cable [2]  
- 5 Screw [3]

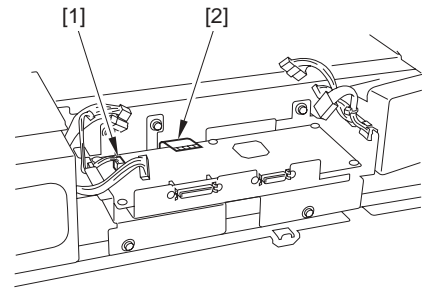

F-5-58

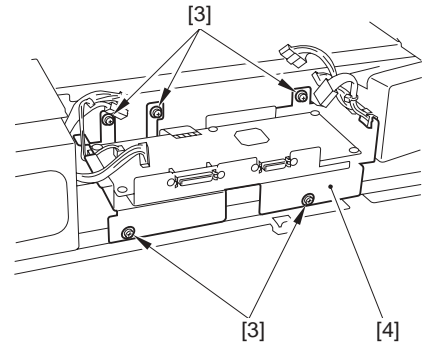

F-5-59

2) Detach the memory PCB [2].  
- 10 Screw [1]

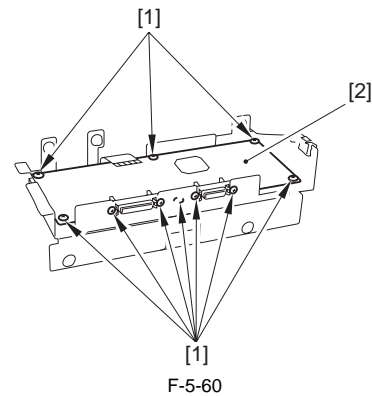

F-5-60

### 5.4.7 Inverter PCB

#### 5.4.7.1 Before removing the inverter PCB

iR5065 / iR 5055 / iR5075 / iR5075N / iR5065N / iR5055N

- 1) Detach the copyboard glass. (page 5-18)Reference[Removing the Copyboard Glass]

#### 5.4.7.2 Removing the Inverter PCB

iR5065 / iR 5055 / iR5075 / iR5075N / iR5065N / iR5055N

- 1) Detach the CCD unit cover [2].  
- 9 Screw [1]

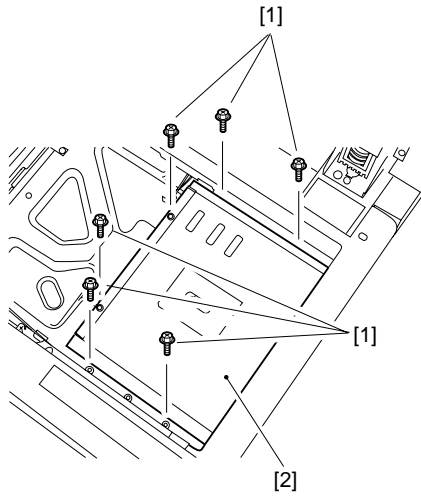

F-5-61

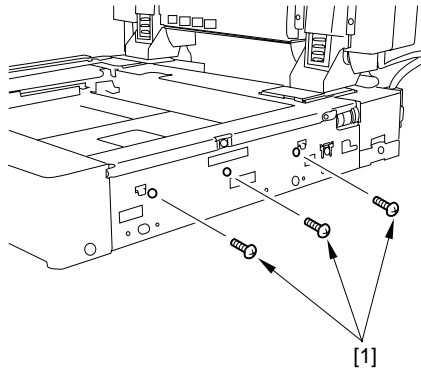

F-5-62

- 2) Detach the inverter PCB [5].
- 1 Connector [1]
  - 1 Flat cable [2]
  - 1 Screw [3]
  - 2 PCB support [4]

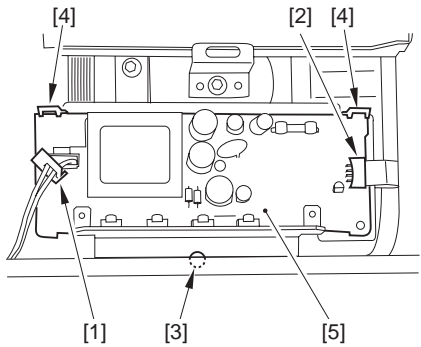

F-5-63

**⚠ How to disconnect the flat cable**  
Slide the locking lever [1] in the direction of the arrow; then, disconnect the flat cable [2].

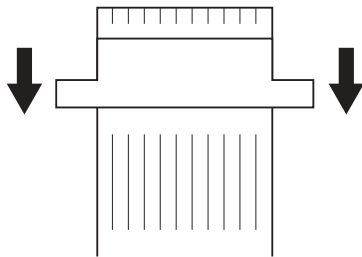

F-5-64

### 5.4.7.3 After Replacing the Inverter PCB

iR5065 / iR 5055 / iR5075 / iR5075N / iR5065N / iR5055N

Execute the following in the service mode.

- 1) White plate data adjustment (COPIER > FUNCTION > CCD > CCD-ADJ).
- 2) ADF white level adjustment (COPIER > FUNCTION > CCD > DF-WLVL1/2).



Be sure to perform white plate data adjustment before performing ADF white level plate.

### 5.4.8 Scanner Motor

#### 5.4.8.1 Before Removing the Scanner Motor

iR5065 / iR 5055 / iR5075 / iR5075N / iR5065N / iR5055N

- 1) Detach the reader rear cover. (page 10-18)Reference[Detaching the Reader Rear Cover]

#### 5.4.8.2 Removing the Scanner Motor

iR5065 / iR 5055 / iR5075 / iR5075N / iR5065N / iR5055N

- 1) Pull out the cover [2].
- 4 Screw [1]

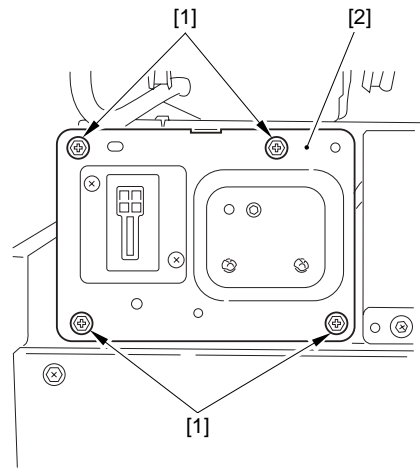

F-5-65

- 2) Remove the 2 reuse bands [2] from the cover [1].

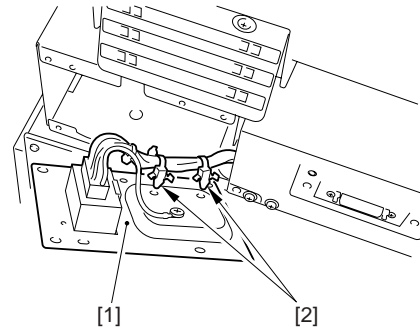

F-5-66

- 3) Move the scanner motor [3] in the direction of the arrow to pull out.
- 3 Screw [1]
  - 2 Spring [2]



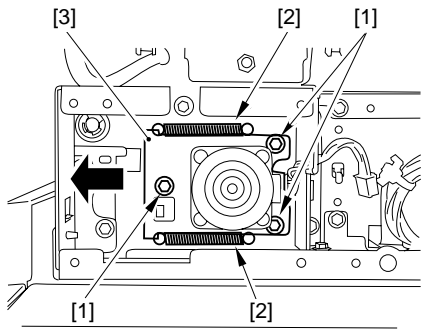

F-5-67

- 4) Detach the scanner motor [2].  
- 1 Connector [1]

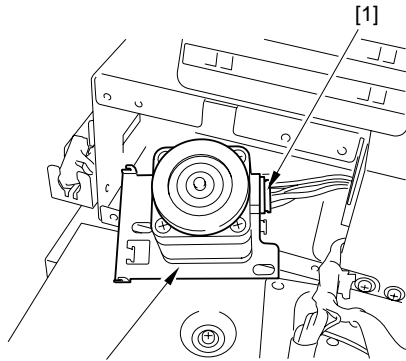

F-5-68

**5.4.8.3 Mounting the Scanner Motor**

iR5065 / iR 5055 / iR5075 / iR5075N / iR5065N / iR5055N

When mounting the scanner motor, check to make sure that the timing belt [3] is properly fitted to the scanner pulley [1] and the motor shaft [2].

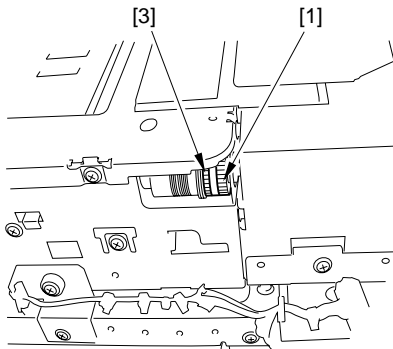

F-5-69

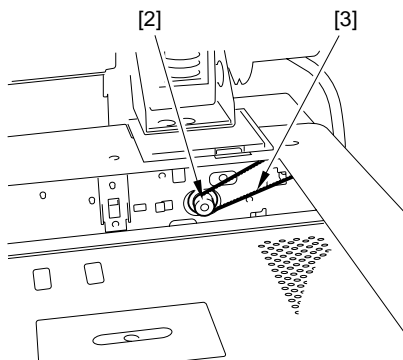

F-5-70

**5.4.9 ADF Open/Close Sensor**

**5.4.9.1 Before Removing the ADF Open/Close Sensor**

iR5065 / iR 5055 / iR5075 / iR5075N / iR5065N / iR5055N

- 1) Detach the reader rear cover. (page 10-18)Reference[Detaching the Reader Rear Cover]

**5.4.9.2 Removing the ADF Open/Close Sensor**

iR5065 / iR 5055 / iR5075 / iR5075N / iR5065N / iR5055N

- 1) Disconnect the connector [1].

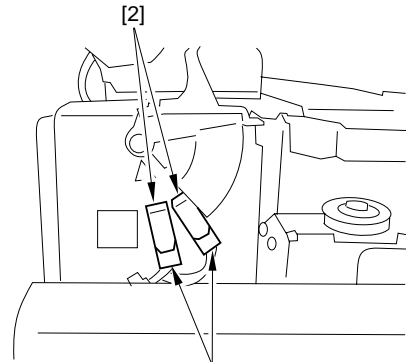

F-5-71

- 2) Detach the reinforcing plate [2].  
- 4 Screw [1]

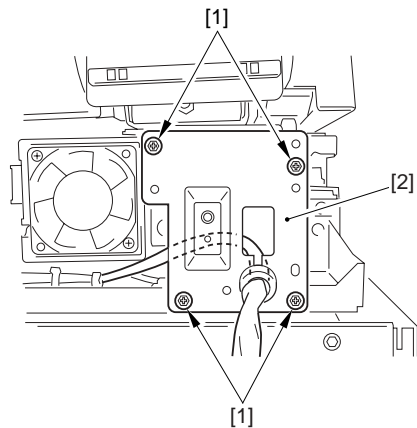

F-5-72

- 3) Detach the ADF open/close sensor (1, 2).  
- Hook [1]

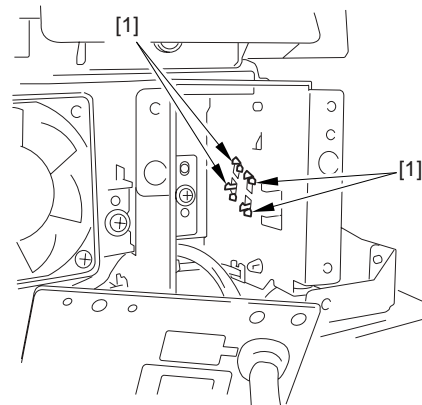

F-5-73

**5.4.10 Scanner HP Sensor**

**5.4.10.1 Before Removing the Scanner HP Sensor**

iR5065 / iR 5055 / iR5075 / iR5075N / iR5065N / iR5055N

- 1) Detach the ADF.  
2) Detach the reader rear cover. (page 10-18)Reference[Detaching the Reader Rear Cover]

**5.4.10.2 Removing the Mirror Base HP Sensor**

iR5065 / iR 5055 / iR5075 / iR5075N / iR5065N / iR5055N

- 1) Detach the reinforcing plate [2].  
- 4 Screw [1]

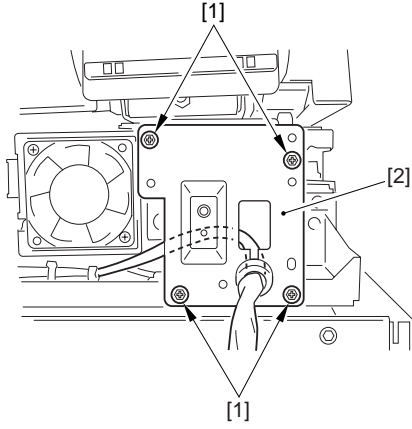

F-5-74

- 2) Detach the sensor base [2].  
- 1 Screw [1]

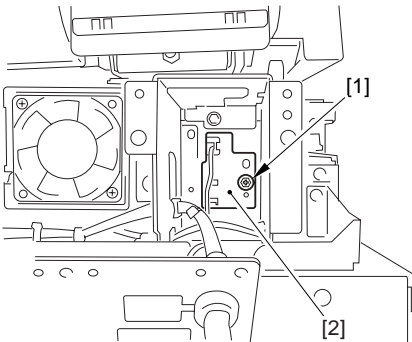

F-5-75

- 3) Detach the home position sensor [1].  
- 1 Connector [1]

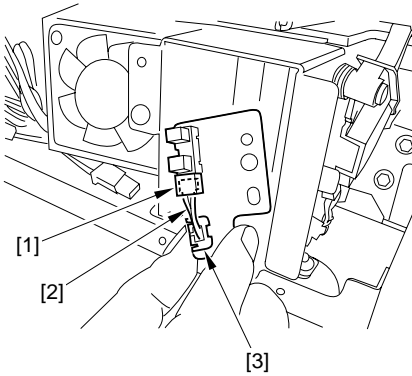

F-5-76

- 4) Detach the home position sensor [2].  
- Hook [1]

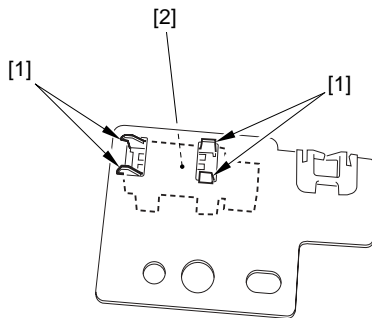

F-5-77

## 5.4.11 Original Size Sensor

### 5.4.11.1 Before Removing the Original Size Sensor

iR5065 / iR 5055 / iR5075 / iR5075N / iR5065N / iR5055N

- 1) Detach the copyboard glass. (page 5-18) Reference [Removing the Copyboard Glass]

### 5.4.11.2 Removing the original size sensor

iR5065 / iR 5055 / iR5075 / iR5075N / iR5065N / iR5055N

- 1) Detach the CCD unit cover [2].  
- 9 Screw [1]

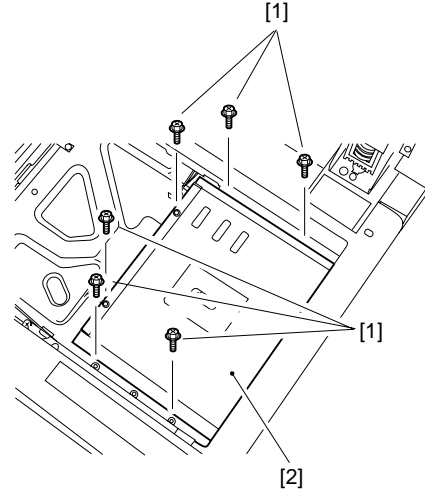

F-5-78

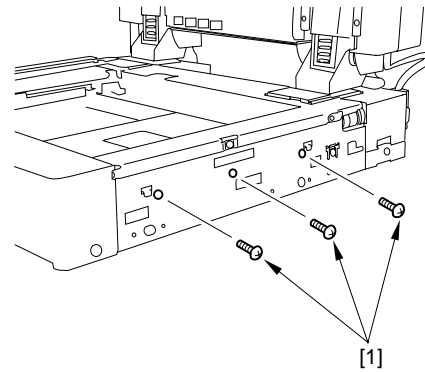

F-5-79

- 2) Shift the original size sensor unit [2].  
- 3 Screw [1]

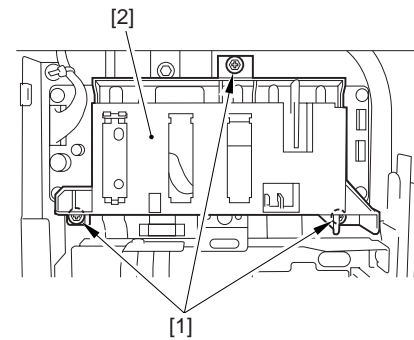

F-5-80

- 3) Detach the original size sensor unit [2].  
- 1 Connector [1]

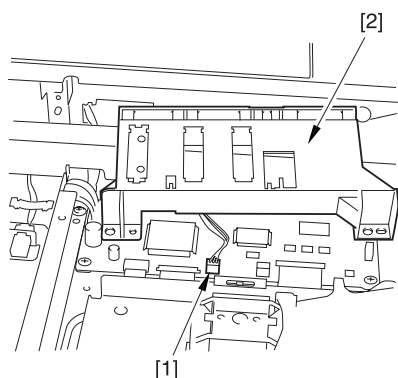

F-5-81

- 4) While freeing the claw at the edge, remove the original size sensor [1].

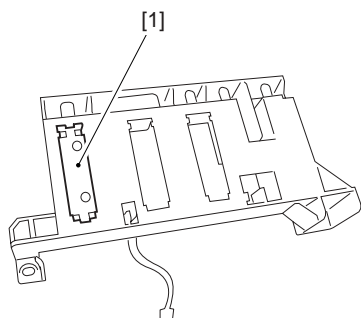

F-5-82

## 5.4.12 Cooling Fan

### 5.4.12.1 Before Removing the Cooling Fan

iR5065 / iR 5055 / iR5075 / iR5075N / iR5065N / iR5055N

- 1) Detach the reader rear cover. (page 10-18)Reference[Detaching the Reader Rear Cover]

### 5.4.12.2 Removing the Cooling Fan

iR5065 / iR 5055 / iR5075 / iR5075N / iR5065N / iR5055N

- 1) Open the wire saddle [1], and disconnect the connector [2].  
2) Detach the cooling fan [4].  
- 2 Screw [3]

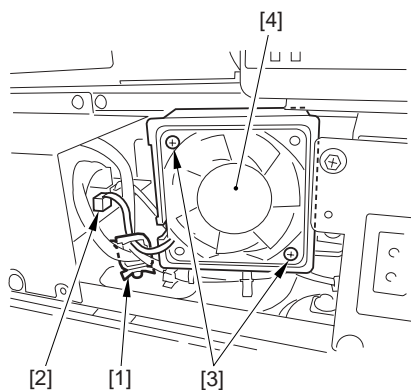

F-5-83

## 5.4.13 Scanner Drive Cable

### 5.4.13.1 Outline

iR5065 / iR 5055 / iR5075 / iR5075N / iR5065N / iR5055N

Be sure to have the following nearby when replacing the scanner drive cable:  
- mirror positioning tool

### 5.4.13.2 Before Removing the Scanner Drive Cable

iR5065 / iR 5055 / iR5075 / iR5075N / iR5065N / iR5055N

- 1) Detach the copyboard glass. (page 5-18)Reference[Removing the Copyboard Glass]

- 2) Detach the right cover (upper). (page 10-12)Reference[Removing the Right Cover (Upper)]  
3) Detach the reader right cover. (page 10-17)Reference[Removing the Reader Right Cover]  
4) Detach the left cover (upper). (page 10-12)Reference[Removing the Left Cover (Upper)]  
5) Detach the reader left cover. (page 10-17)Reference[Removing the Reader Left Cover]  
6) Detach the reader front cover. (page 10-17)Reference[Detaching the Reader Front Cover]  
7) Detach the reader rear cover. (page 10-18)Reference[Detaching the Reader Rear Cover]  
8) Detach the ADF.  
9) Detach the control panel. (page 10-23)Reference[Removing Control Panel]

### 5.4.13.3 Removing the Scanner Drive Cable

iR5065 / iR 5055 / iR5075 / iR5075N / iR5065N / iR5055N

- 1) Detach the stream reading glass retainer [2].  
- 2 Screw [1]



When detaching the stream reading glass retainer, be sure to take care so that the leaf spring will not come off.

- 2) Remove the stream reading glass [3].  
3) Detach the left glass retainer [5].  
- 2 Screw [4]

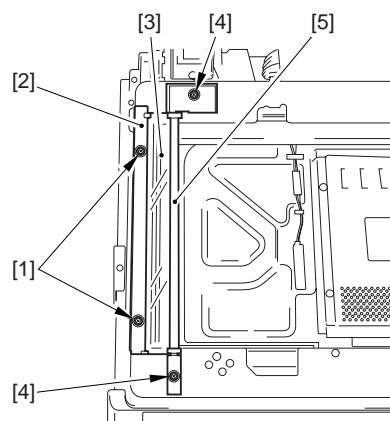

F-5-84



- When mounting the stream reading glass retainer, be sure to hold down both edges of the leaf spring [A] while fixing it in place. (Take care not to bend the leaf spring.)
- Be sure to mount it while butting the stream reading glass retainer [B] against the stream reading glass [C].
- Check to be sure that the side of the stream reading glass in contact with the leaf spring [D] of the stream reading glass retainer.
- If not, dust can collect on the stream reading glass, causing lines in output images.

- 1 Screw [1]

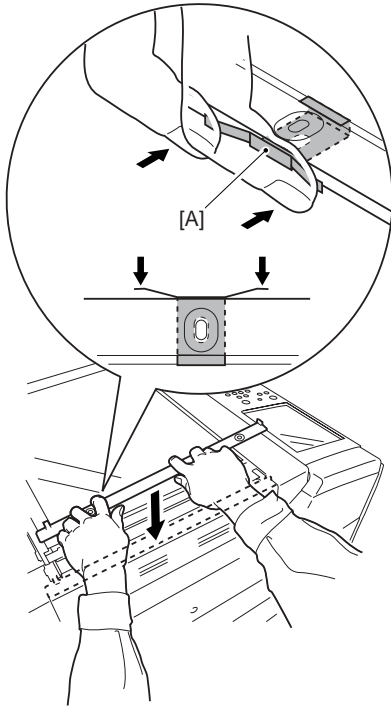

F-5-85

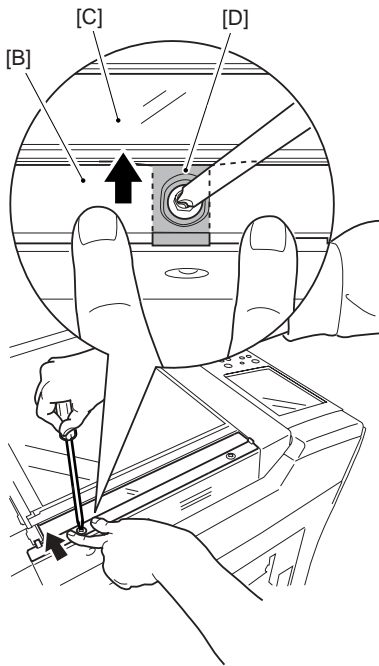

F-5-86

4) Detach the ADF right screw cover [2].  
- 1 Screw [1]

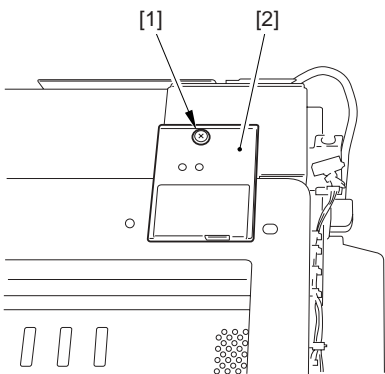

F-5-87

5) Detach the ADF left screw cover [2].

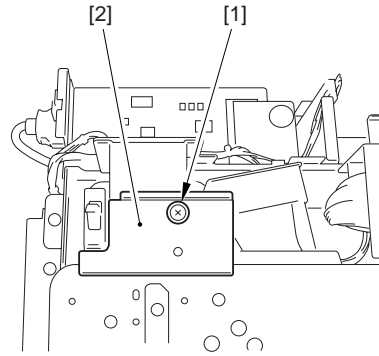

F-5-88

6) Detach the interface PCB mount [4].  
- Connector [1] 9pc.  
- Flat cable [2] 1pc.  
- Screw [3] 9pc.

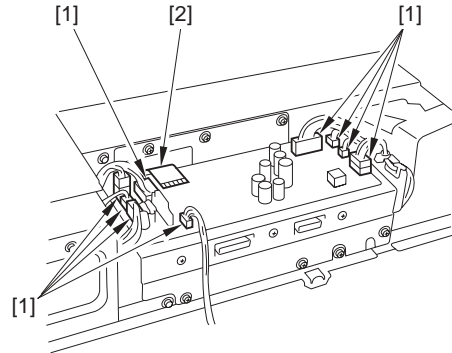

F-5-89

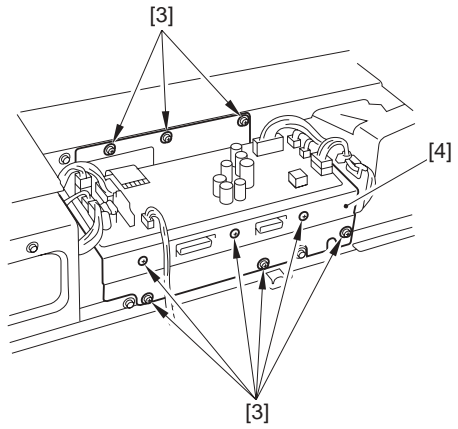

F-5-90

7) Detach the memory PCB mount [4].  
- Connector [1] 1pc.  
- Flat cable [2] 1pc.  
- Screw [3] 5pc.

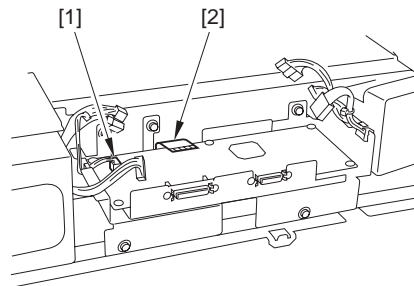

F-5-91

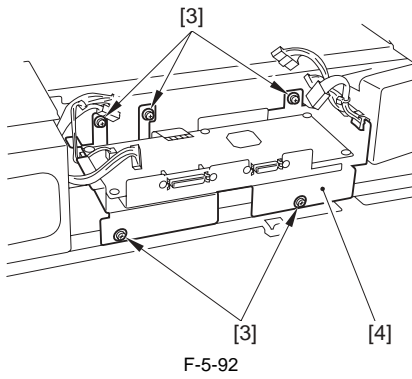

F-5-92

- 8) Open the 2 wire saddles [1].
- 9) Detach the motor cover [3] together with the harness.
  - Screw [2] 4pc.

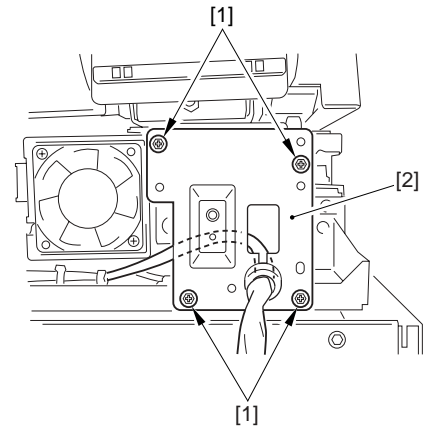

F-5-96

- 13) Free the harness from the wire saddle [3].
  - 2 Connector [1]
  - 1 Snap band [2]

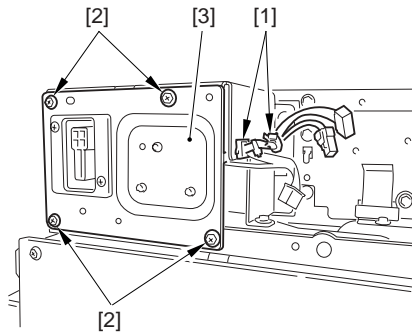

F-5-93

- 10) Free the harness from the wire saddle [1], and detach the motor frame [3].
  - 6 Screw [2]

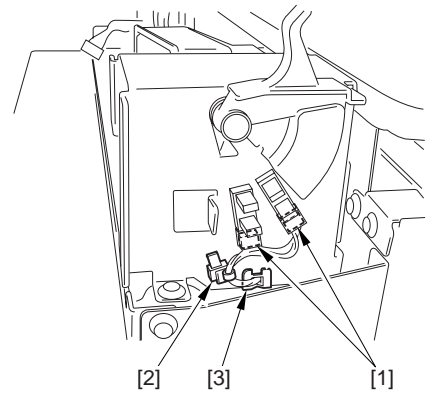

F-5-97

- 14) Free the harness from the 3 wire saddles [1], and detach the ADF open/close sensor base [3].
  - 6 Screw [2]

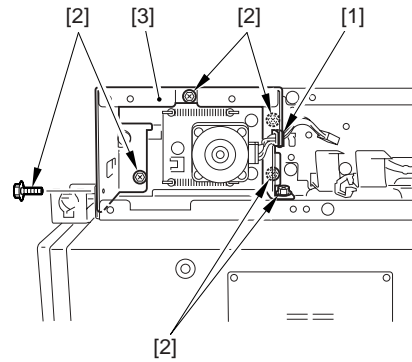

F-5-94

- 11) Disconnect the connectors [1] of the reader unit communication cable.

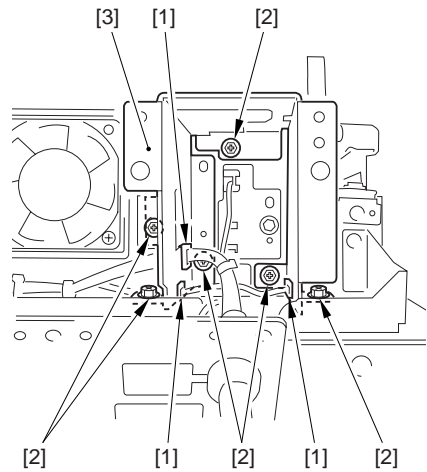

F-5-98

- 15) Detach the reader upper frame [2].
  - 24 Screw [1]

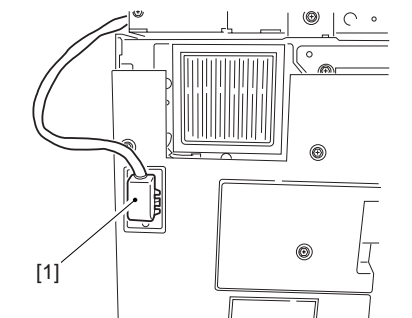

F-5-95

- 12) Shift the reinforcing plate [2] to the front.
  - 4 Screw [1]

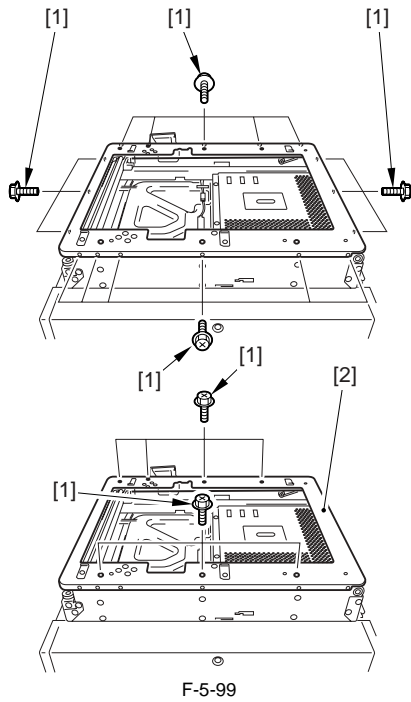

F-5-99



In the next steps, draw mark-off lines before removing the screw.

- 16) Remove the 2 cable fixing screws [2] of the No. 1 mirror base [1].
- 17) Remove the cable fixing spring [3].
- 18) Free the 2 hooks [4] of the cable from the right side of the reader unit frame.
- 19) Detach the cable for the pulleys.

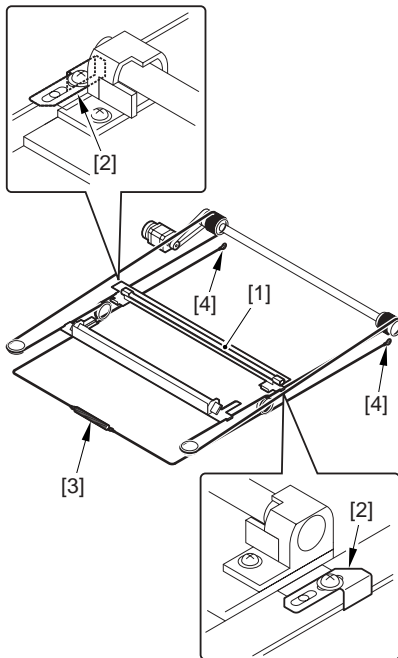

F-5-100

#### 5.4.13.4 Fitting the Scanner Drive Cable

iR5065 / iR 5055 / iR5075 / iR5075N / iR5065N / iR5055N

- 1) Put the ball of the cable into the hole of the drive pulley [1], and wind the cable (4 times inside; 5 times outside); then, tape it in place. At this time, make sure that the cable fixing [2] is on the inside.
- 2) Fit the cable on the pulleys; then, fit one end on the left side hook [3] and the other end on the right side hook [4].
- 3) Temporarily fix the cable fixing plate [2] in place on the No. 1 mirror base [5].
- 4) Mount the reader unit upper frame.

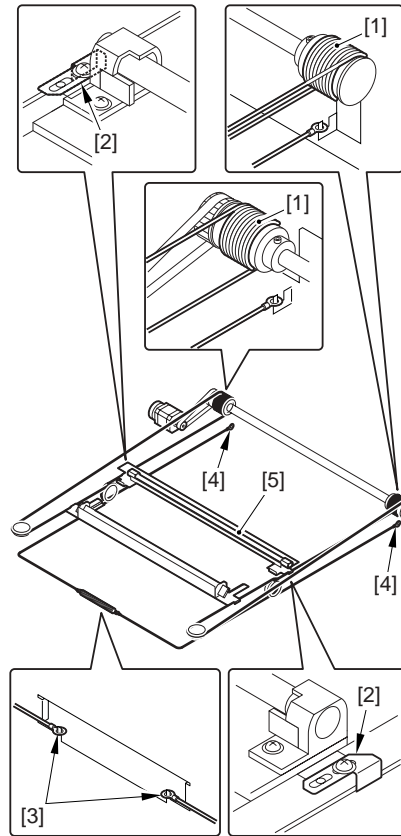

F-5-101

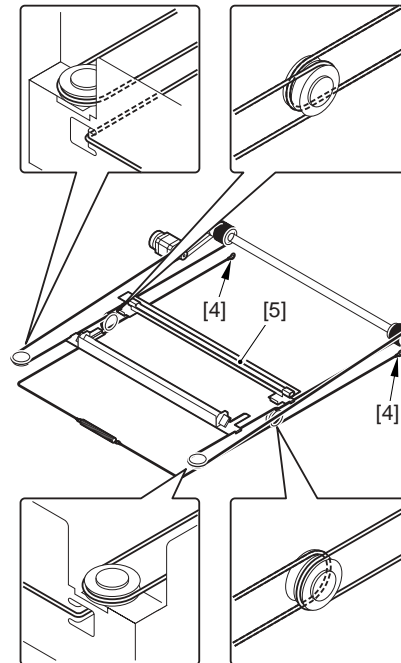

F-5-102

#### 5.4.13.5 Adjusting the Position of the No. 1/No. 2 Mirror Base

iR5065 / iR 5055 / iR5075 / iR5075N / iR5065N / iR5055N

- 1) Arrange the mirror positioning tool (FY9-3009-040) so that it is ready for use in the machine (by changing the pin position; REAR).

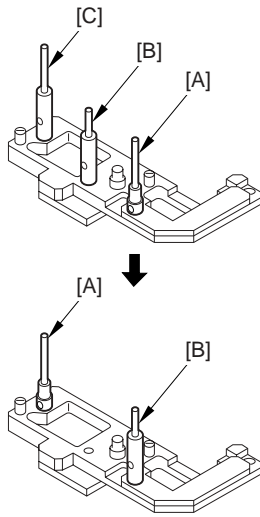

F-5-103

2) Arrange the mirror positioning tool so that it is ready for use in the machine (by changing the pin position; FRONT).

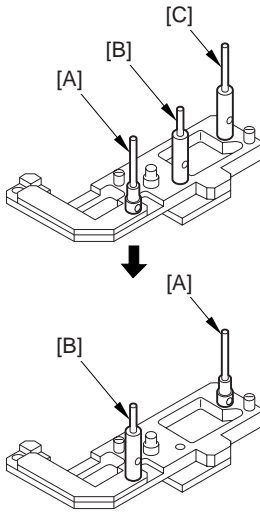

F-5-104

3) Fit the pins of the mirror positioning tool (front [2]; rear [3]) into the appropriate holes [1] of the No. 1/No. 2 mirror base.

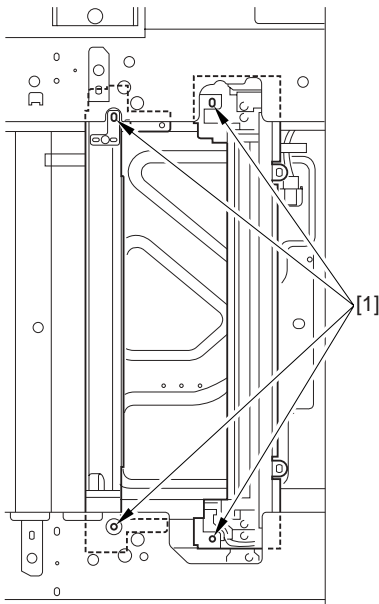

F-5-105

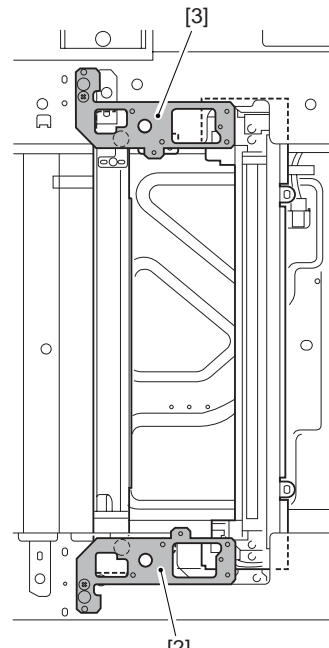

F-5-106

- 4) Secure the end of the cable that has temporarily been fixed in place on the hook of the reader unit frame.
- 5) Fully tighten the screws on the cable fixing plate both at the front and the rear.
- 6) Detach the mirror positioning tool (FRONT, REAR).
- 7) Put the detached parts back on by reversing the foregoing steps.

#### 5.4.14 Waste Toner Box Holder

##### 5.4.14.1 Before Removing the Collecting Toner Bottle Holder

iR5065 / iR 5055 / iR5075 / iR5075N / iR5065N / iR5055N

- 1) Remove the charger unit (this step is necessary only for iR5075 for Japan). (page 10-22) Reference[Removing the Charger unit]
- 2) Remove the rear cover (upper). (page 10-13) Reference[Removing the Rear Cover (Upper)]
- 3) Detach the rear cover (lower). (page 10-13) Reference[Removing the Rear Cover (Lower)]
- 4) Detach the right cover (lower rear). (page 10-12) Reference[Removing the Right Cover (Lower Rear)]

##### 5.4.14.2 Removing the Collecting Toner Bottle Holder

iR5065 / iR 5055 / iR5075 / iR5075N / iR5065N / iR5055N

- 1) Remove the collecting toner bottle.
- 2) Move the main power switch base [3] to the side.
  - 2 Screw [1]
  - 2 Wire saddle [2] (to free the harness)

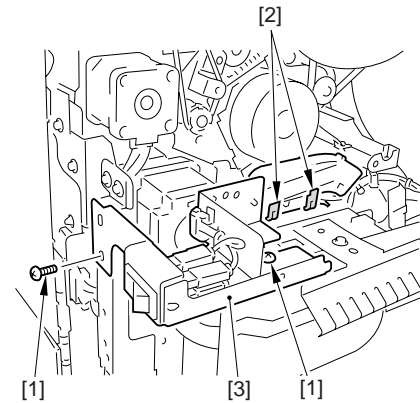

F-5-107

- 3) Detach the connector base [3].
  - 5 Connector [1]
  - 2 Screw [2]

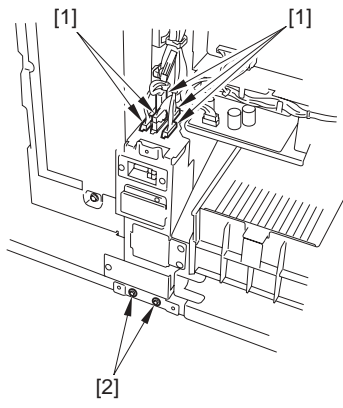

F-5-108

- 4) Detach the collecting toner bottle holder [2].  
- 2 Screw [1]
- 



Take care not to spill the collecting toner.

---

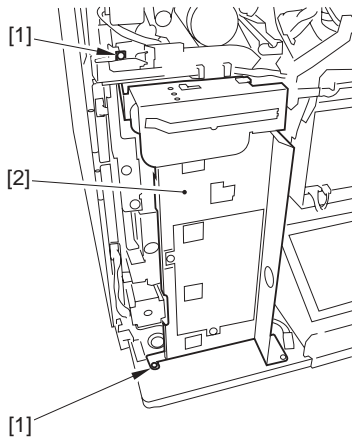

F-5-109



---

## Chapter 6 Laser Exposure

---



---

# Contents

6.1 Construction .....	6-1
6.1.1 Overview .....	6-1
6.1.2 Major Components.....	6-1
6.2 Basic Sequence .....	6-2
6.2.1 Basic Sequence of Operation (laser exposure) .....	6-2
6.3 Various Controls .....	6-2
6.3.1 Controlling the Laser Activation Timing.....	6-2
6.3.1.1 Generating the Sync Signal.....	6-2
6.3.1.2 Flow of the Sync Signal .....	6-2
6.3.2 Controlling the Intensity of Laser Light .....	6-2
6.3.2.1 Controlling the Laser Intensity.....	6-2
6.3.2.2 APC Control.....	6-3
6.3.3 Controlling the Laser Scanner Motor .....	6-4
6.3.3.1 Controlling the Laser Scanner Motor.....	6-4
6.4 Parts Replacement Procedure.....	6-5
6.4.1 Laser Scanner Unit.....	6-5
6.4.1.1 Removing the Laser Scanner Unit .....	6-5
6.4.1.2 When Replacing the Laser Scanner Unit .....	6-5



## 6.1 Construction

### 6.1.1 Overview

iR5065 / iR 5055 / iR5075 / iR5075N / iR5065N / iR5055N

The machine's laser exposure system consists of the laser unit that serves as the source of light and the laser scanning unit that uses a polygon mirror to control the beam of laser light (for main scanning direction).

- 1) The video signal from the controller block is converted into a laser drive signal by the video PCB, and is sent to the laser drive PCB. The laser drive signal is used to turn on the laser unit for generation of a laser beam.
- 2) The laser beam will assume a specific scanning direction upon hitting the polygon mirror rotating at a high speed.
- 3) The surface of the photosensitive drum is charged to a positive potential. When the laser beam hits specific areas of the drum surface, a static image occurs as a result.

In addition, the laser beam is also used for blank exposure applied to non-imaging areas.

T-6-1

Item	Description
Laser intensity control	[1] laser power auto control (APC control) [2] optimum intensity control to suit drum surface potential
Laser scanning method	scanning by semi-conductor laser
synchronization control	main scanning direction: control by BD signal sub scanning direction: controlled by laser write start signal
Laser scanner motor control	[1] constant speed rotation control [2] full/standby speed switchover

### 6.1.2 Major Components

iR5065 / iR 5055 / iR5075 / iR5075N / iR5065N / iR5055N

The machine's laser exposure system consists of the following major components:

The machine uses a small-diameter 12-facet polygon mirror and a wide-area lens to enable scanning at high speed, at low power consumption, and at low operating noise. The laser unit is a double-beam unit.

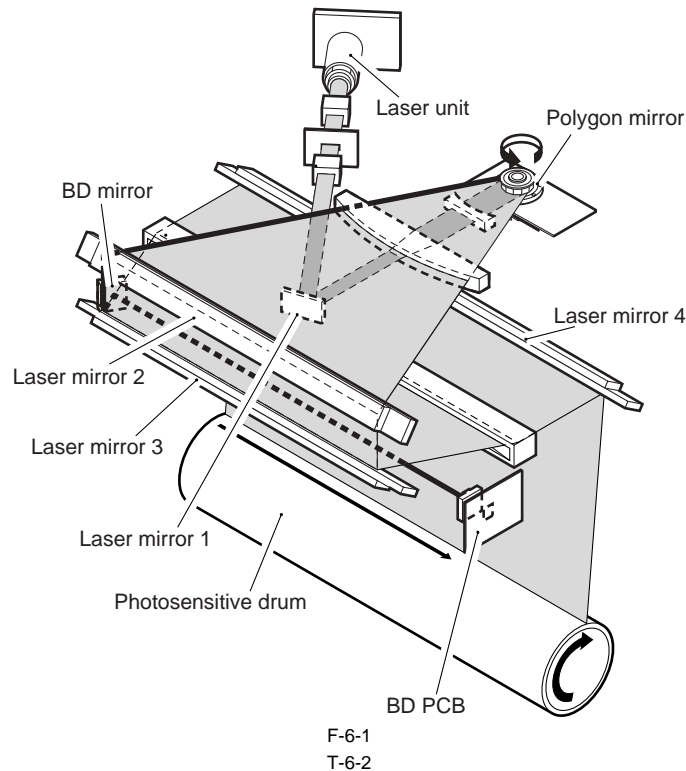

Item	Description
Laser semi-conductor	visible laser light (about 660 nm), double beam
Laser scanner motor	DC motor, 2-speed control (at full speed, about 41338 rpm)
Polygon mirror	12 facets
BD mirror/BD PCB	laser beam detection
laser driver PCB	Laser activation control
Video PCB	laser scanner motor rotation control

## 6.2 Basic Sequence

### 6.2.1 Basic Sequence of Operation (laser exposure)

iR5065 / iR 5055 / iR5075 / iR5075N / iR5065N / iR5055N

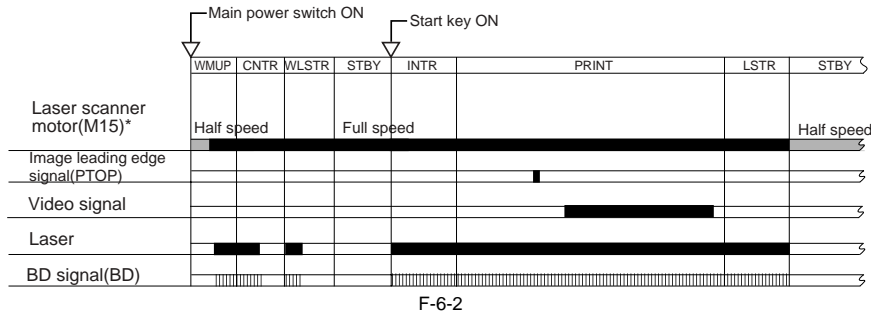

## 6.3 Various Controls

### 6.3.1 Controlling the Laser Activation Timing

#### 6.3.1.1 Generating the Sync Signal

iR5065 / iR 5055 / iR5075 / iR5075N / iR5065N / iR5055N

The BD signal used to synchronize the video signal in laser scanning direction is generated by the BD PCB with reference to the laser beam reflected by the BD mirror mounted on the laser beam optical path. The CCD/AP PCB reads the image signal from the CCD, and sends it to the controller block. The controller block, in response, executes image processing, and sends the result as a video signal to the laser driver PCB and as the laser intensity control signal to the laser unit.

#### 6.3.1.2 Flow of the Sync Signal

iR5065 / iR 5055 / iR5075 / iR5075N / iR5065N / iR5055N

- [1] BD signal (upon detection of laser light, '0').
- [2] phase matching is executed with reference to the printer, and the synch signal is generated.
- [3] reads the image data from the image memory in keeping with the printer sync signal.
- [4] video signal
- [5] converts the 2-pixel parallel signal into a signal-pixel serial signal.
- [6] laser drive signal (drives the laser unit according to the video signal).

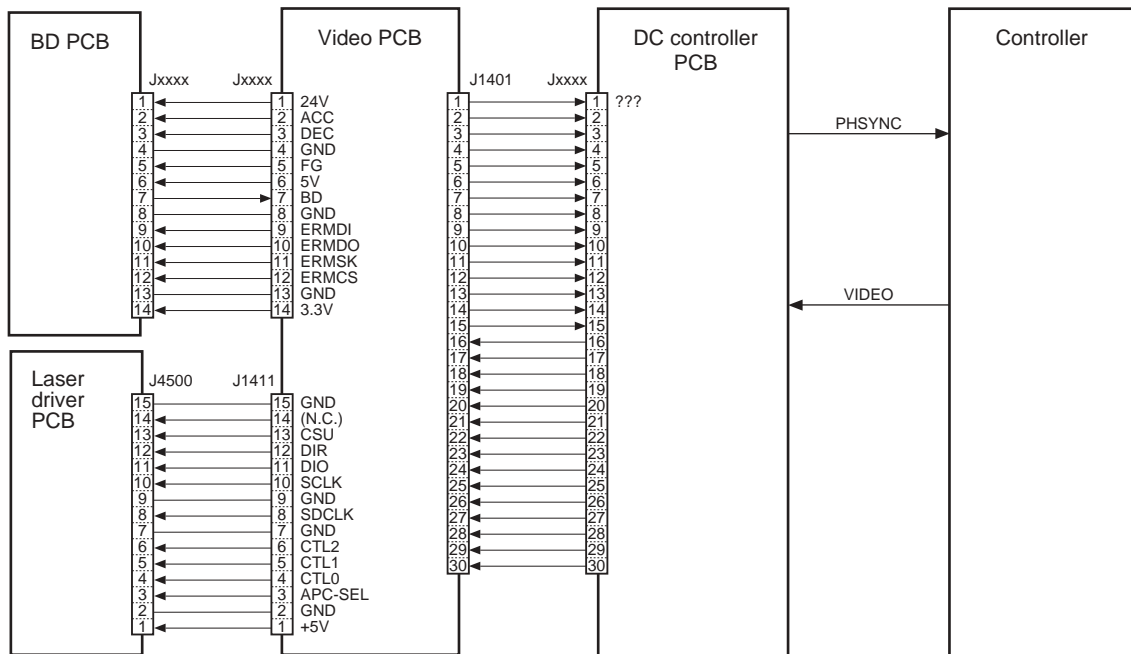

F-6-3

### ERROR DODE:

#### E100

Issued when the BD signal is not detected within a specific period of time after the laser has been turned on.

### 6.3.2 Controlling the Intensity of Laser Light

#### 6.3.2.1 Controlling the Laser Intensity

iR5065 / iR 5055 / iR5075 / iR5075N / iR5065N / iR5055N

The laser driver circuit serves to drive the semi-conductor laser with reference to the laser drive signal (LD) coming from the DC controller PCB.

The laser drive circuit is associated with the following items of control:

- laser activation control
- laser intensity control (APC control)
- laser intensity control to suit the drum surface potential

The various signals have the following meanings and functions:

- [1] sample laser activation signal; for each scan, it turns on the laser for sampling of light intensity (for imaging)
- [2] laser activation enable signal; after the Start key has been pressed, it goes '0' when the laser is ready for activation.
- [3] laser write start signal; when paper reaches the laser write start sensor (PS28) mounted in front of the registration roller, the machine starts laser write operation.
- [4] the machine monitors the intensity of laser light upon its activation (for sampling), and feeds the appropriate value to the laser drive circuit.
- [5] the machine controls the output so that the value that has been fed and the reference value from the DC controller are identical.
- [6] laser intensity reference signal; it serves as the laser activation reference (determined as a result of potential control by the DC controller).

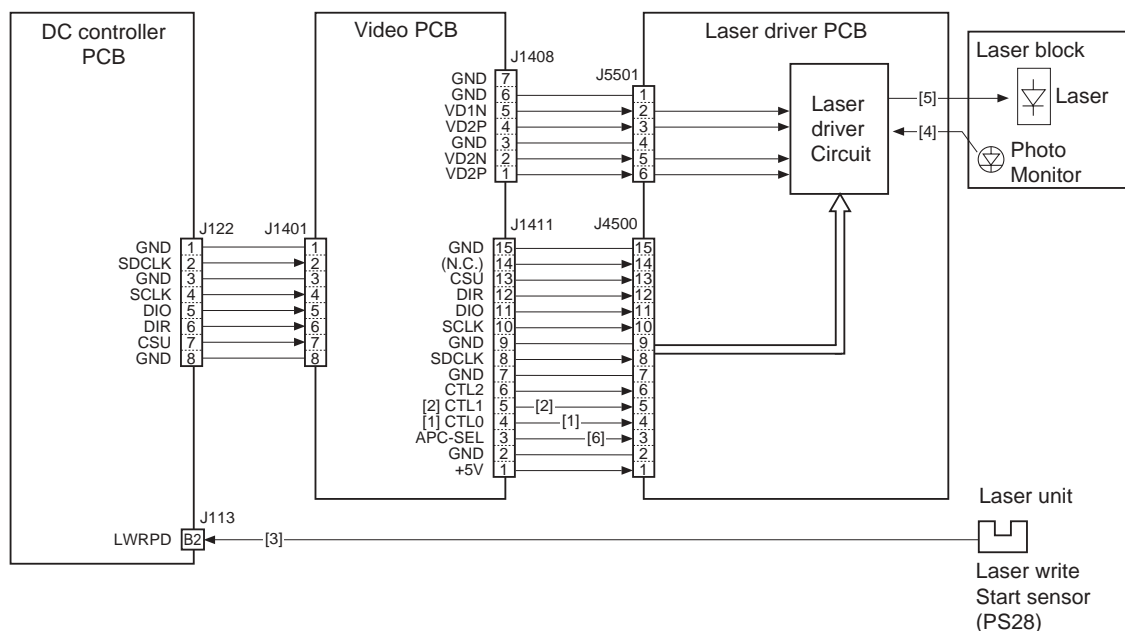

F-6-4

#### MEMO:

- The laser power is adjusted automatically when the laser unit is replaced.
- When the manual feed tray is used as the source of paper, the write operation starts when the registration paper sensor (PS29) detects paper.

#### SERVICE MODE:

**DISPLAY> DPOT> LLMT**

indicates the laser power voltage control value for copier imaging.

**DISPLAY> DPOT> LPOWER-P**

indicates the result of potential control for the laser intensity used during printer (PDL) imaging.

**DISPLAY> DPOT> LPOWER-C**

indicates the result of potential control for the laser intensity used during copier imaging.

**DISPLAY> MISC> LPOWER**

indicates the laser intensity in real time.

**ADJUST> LASER> PVE-OFST**

used to adjust the laser incident point.

**FUNCTION> LASER> POWER**

used to turn on laser light.

#### 6.3.2.2 APC Control

iR5065 / iR 5055 / iR5075 / iR5075N / iR5065N / iR5055N

The machine executes APC control so that the laser light will remain at a constant level by adjusting the output of the laser diode mounted on the laser driver. The control mechanism takes place on the DC control PCB.

The DC controller sends the laser control signal (LD1: CTL0=0, CTL1=1, CTL2=0; LD2: CTL0=1, CTL1=0, CTL2=0; both APC-SEL=0) to the laser driver IC on the laser driver PCB.

In response, the laser driver IC sets APC mode, and forces the laser diode (LD) to emit light.

While all this is under way, the laser driver IC monitors the laser diode (LD) by means of a photo diode (PD), and adjusts the output of the laser diode unit so that the intensity is at a specific level.

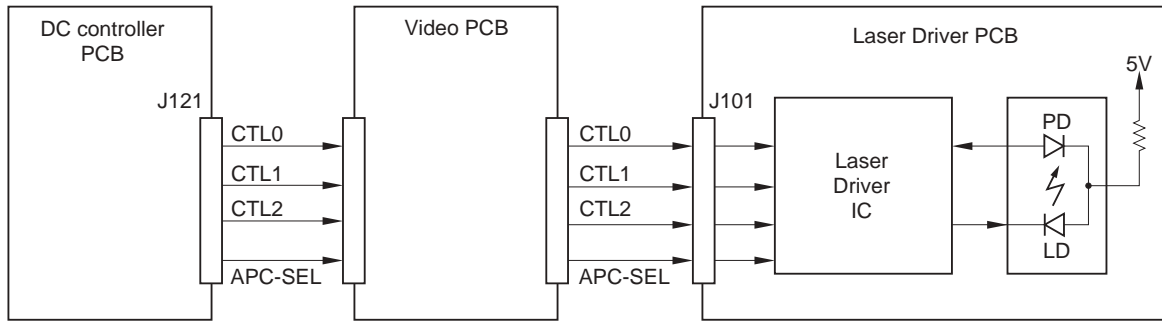

F-6-5

### 6.3.3 Controlling the Laser Scanner Motor

#### 6.3.3.1 Controlling the Laser Scanner Motor

iR5065 / iR 5055 / iR5075 / iR5075N / iR5065N / iR5055N

The machine controls the laser scanner motor so that the motor always rotates at a specific speed.

The control mechanism takes place in the motor speed control block.

The motor speed control block detects the speed detection signal (FG, BD), and compares it against the reference signal generated by the reference signal generation block on the DC controller PCB; it then controls the acceleration signal (ACC) and the deceleration signal (DEC) so that the motor will rotate at a specific speed. The machine switches over speed detection to suit the current printer state, thereby reducing the time used to control the scanner motor.

The FG signal is a detection signal used for rough adjustment of the motor speed, while the BD signal is a detection point signal used to fine-tune the motor speed.

T-6-3

Start-up	startup -> half speed	FG control
	half speed -> full speed	FG -> BD control
STBY	half speed	FG control
Imaging	full speed	BD control
Deceleration	full speed -> half speed	BD -> FG control
	half speed -> stop	FG control

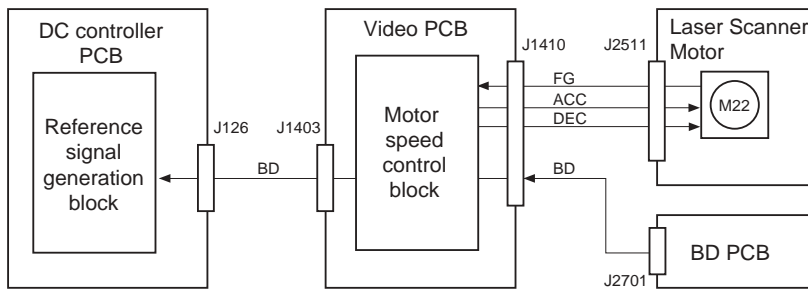

F-6-6

#### ERROR CODE:

##### E110 (scanner motor error)

-0001: after the scanner motor has been started up, the FG signal is not detected within a specific period of time, or while the scanner motor is rotating at a stable speed, the FG signal is not detected.



2) Turn off and then back on the main power switch.

## 6.4 Parts Replacement Procedure

### 6.4.1 Laser Scanner Unit

#### 6.4.1.1 Removing the Laser Scanner Unit

iR5065 / iR 5055 / iR5075 / iR5075N / iR5065N / iR5055N

- 1) Open the right door unit (upper); then, remove the 1 screw [2] from the door strap, and fully open the right door unit (upper).

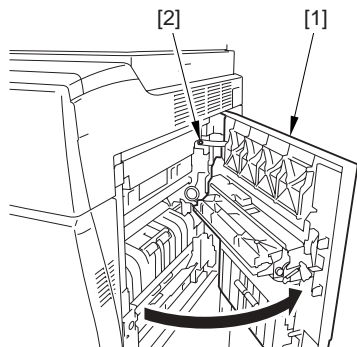

F-6-7

- 2) Slide the developing assembly locking unit [2] in the direction of the arrow to detach.
  - 1 Screw [1]
- 3) Detach the scanner cover [4].
  - 4 Screw [3]

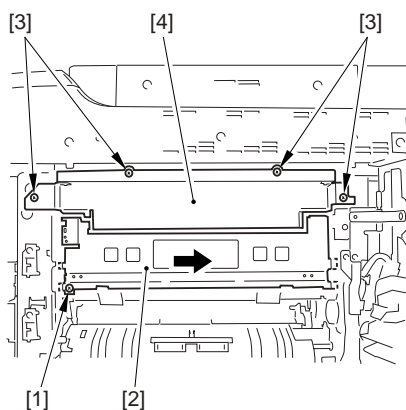

F-6-8

- 4) Disconnect the 4 connectors [1].
- 5) Detach the 1 leaf spring [3].
  - 2 Screw [2]
- 6) Hold the front of the laser scanner unit [4], and lift and take out.

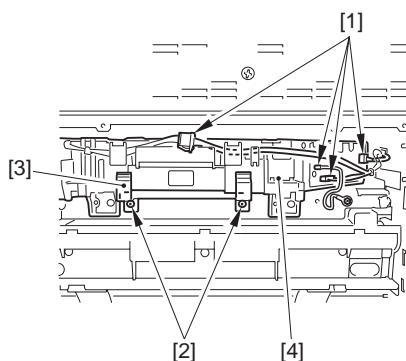

F-6-9

#### 6.4.1.2 When Replacing the Laser Scanner Unit

iR5065 / iR 5055 / iR5075 / iR5075N / iR5065N / iR5055N

If the temperature of the fixing assembly is 150 deg C or higher when the main power switch is turned on, the machine will not execute potential control. If such is the case after replacing the scanner unit, manually execute potential control in service mode as follows:

- 1) Make the following selections in service mode: COPIER> FUNCTION> DPC> DPC; then, enter '1', and press [OK].



---

## Chapter 7 Image Formation

---



---

# Contents

7.1 Construction .....	7-1
7.1.1 Overview .....	7-1
7.1.2 Major Components .....	7-1
7.2 Image Formation Process .....	7-1
7.2.1 Overview .....	7-1
7.3 Basic Sequence .....	7-2
7.3.1 At Power-On .....	7-2
7.3.2 At Time of Printing .....	7-3
7.4 Potential Control .....	7-3
7.4.1 Overview .....	7-3
7.4.2 Copier/Printer Potential Control .....	7-3
7.4.3 Determining the Primary Current .....	7-6
7.4.4 Determining the Laser Output .....	7-6
7.4.5 Determining the Developing Bias .....	7-6
7.4.6 APC Correction .....	7-7
7.4.7 Adjusting the Density in Various Modes .....	7-7
7.5 Charging Mechanism .....	7-8
7.5.1 Controlling Pre-Exposure LED .....	7-8
7.5.1.1 Pre-Exposure LED Control .....	7-8
7.5.2 Primary Charging Mechanism .....	7-9
7.5.2.1 Overview .....	7-9
7.5.2.2 Primary Charging Assembly Cleaning Mechanism .....	7-9
7.5.2.3 Others .....	7-10
7.5.3 Dust-Collecting Roller Bias .....	7-10
7.5.3.1 Overview .....	7-10
7.5.4 Pre-Transfer Charging Mechanism .....	7-11
7.5.4.1 Overview .....	7-11
7.5.4.2 Controlling the Output to Suit the Environment (fuzzy control) .....	7-11
7.5.4.3 Pre-Transfer Charging Assembly Cleaning Mechanism .....	7-12
7.5.4.4 Others .....	7-12
7.6 Drum Cleaner Unit .....	7-12
7.6.1 Overview .....	7-12
7.6.2 Detecting the State (full) of the Collecting Toner Case .....	7-13
7.6.3 Drum/Separation Claw Bias Control .....	7-14
7.7 Developing Assembly .....	7-14
7.7.1 Controlling the Developing Assembly Drive .....	7-14
7.7.2 Controlling the Developing Bias .....	7-14
7.7.3 Detecting the Toner Level and Controlling Toner Supply .....	7-15
7.8 Transfer Mechanism .....	7-16
7.8.1 Transfer Charging Mechanism .....	7-16
7.8.1.1 Overview .....	7-16
7.8.1.2 Controlling the Output to Suit the Environment (fuzzy control) .....	7-16
7.8.1.3 Transfer Charging Assembly Cleaning Mechanism .....	7-17
7.8.1.4 Others .....	7-17
7.9 Separation Mechanism .....	7-18
7.9.1 Separation Charging Mechanism .....	7-18
7.9.1.1 Overview .....	7-18
7.9.1.2 Correcting the Output to Suit the Environment and the Drum Surface Potential .....	7-18
7.9.1.3 Others .....	7-19
7.10 Parts Replacement Procedure .....	7-20
7.10.1 Process Unit .....	7-20

7.10.1.1 Before Removing Process Unit.....	7-20
7.10.1.2 Removing Process Unit .....	7-20
7.10.1.3 Mounting Process Unit .....	7-20
7.10.2 Pre-Exposure Lamp .....	7-21
7.10.2.1 Before Removing Pre-Exposure Lamp .....	7-21
7.10.2.2 Removing Pre-Exposure Lamp .....	7-21
7.10.2.3 Cleaning Primary Toner Blocking Sheet .....	7-21
7.10.3 Primary Charging Assembly.....	7-21
7.10.3.1 Before Removing Primary Charging Assembly .....	7-21
7.10.3.2 Removing Primary Charging Assembly .....	7-21
7.10.4 Pre-Transfer Charging Assembly .....	7-22
7.10.4.1 Before Removing Pre-Transfer Charging Assembly .....	7-22
7.10.4.2 Removing Pre-Transfer Charging Assembly.....	7-22
7.10.5 Photosensitive Drum .....	7-22
7.10.5.1 Points to Note When Handling Photosensitive Drum .....	7-22
7.10.5.2 Before Removing Photosensitive Drum .....	7-22
7.10.5.3 Removing Photosensitive Drum .....	7-22
7.10.5.4 Cleaning Photosensitive Drum .....	7-23
7.10.6 Drum Motor .....	7-23
7.10.6.1 Before Removing Drum Motor .....	7-23
7.10.6.2 Removing Drum Motor .....	7-23
7.10.7 Photosensitive Drum Heater .....	7-24
7.10.7.1 Points to Note When Handling Photosensitive Drum .....	7-24
7.10.7.2 Before Removing Photosensitive Drum Heater .....	7-24
7.10.7.3 Removing Drum Heater .....	7-24
7.10.7.4 Points to Note When Mounting Drum Heater .....	7-24
7.10.8 Cleaning Blade.....	7-24
7.10.8.1 Configuration .....	7-24
7.10.8.2 Before Removing Cleaning Blade .....	7-24
7.10.8.3 Removing Cleaning Blade .....	7-24
7.10.8.4 Mounting Cleaning Blade .....	7-25
7.10.9 Side Seal.....	7-25
7.10.9.1 Before Removing Side Seal .....	7-25
7.10.9.2 Removing Side Seal .....	7-26
7.10.10 Cleaner Scraper.....	7-26
7.10.10.1 Before Cleaning Cleaner Scraper .....	7-26
7.10.10.2 Cleaning Cleaner Scraper .....	7-26
7.10.11 Hopper Assembly.....	7-26
7.10.11.1 Before Removing Hopper Assembly .....	7-26
7.10.11.2 Removing Hopper Assembly .....	7-26
7.10.12 Hopper Supply Motor .....	7-27
7.10.12.1 Before Removing Toner Supply Motor .....	7-27
7.10.12.2 Removing Toner Supply Motor .....	7-27
7.10.13 Hopper String Motor .....	7-27
7.10.13.1 Before Removing Hopper Stirring Motor .....	7-27
7.10.13.2 Removing Hopper Stirring Motor .....	7-27
7.10.14 Developing Assembly .....	7-28
7.10.14.1 Removing Developing Assembly .....	7-28
7.10.14.2 Cleaning Developing Toner Blocking Sheet .....	7-28
7.10.15 Developing Cylinder.....	7-29
7.10.15.1 Before Removing Developing Cylinder .....	7-29
7.10.15.2 Removing Developing Cylinder .....	7-29
7.10.16 Developing Blade.....	7-29
7.10.16.1 Before Removing Developing Blade .....	7-29
7.10.16.2 Removing Developing Blade .....	7-29
7.10.16.3 Mounting Developing Blade.....	7-29
7.10.17 Transfer/Separation Charging Assembly.....	7-30
7.10.17.1 Removing Transfer/Separation Charging Assembly .....	7-30
7.10.17.2 Mounting Transfer/Separation Charging Assembly .....	7-30
7.10.18 Separation Claw/Separation Claw Drive Assembly .....	7-30

7.10.18.1 Before Removing Separation Claw Holder .....	7-30
7.10.18.2 Removing Separation Claw Holder .....	7-30
7.10.19 Potential Sensor Unit .....	7-31
7.10.19.1 Outline.....	7-31
7.10.19.2 Before Removing Potential Sensor Unit .....	7-31
7.10.19.3 Removing Potential Sensor Unit .....	7-31
7.10.20 Charging Wire.....	7-31
7.10.20.1 Outline.....	7-31
7.10.20.2 Routing Charging Wire .....	7-31
7.10.20.3 Routing Grid for Primary Charging Assembly .....	7-32
7.10.20.4 Adjusting Height of Charging Wire .....	7-32





## 7.1 Construction

### 7.1.1 Overview

iR5065 / iR 5055 / iR5075 / iR5075N / iR5065N / iR5055N

The following shows the functions of and the methods used by the machine's image formation system:

T-7-1

Item	Description
Photosensitive drum	amorphous silicon (80-mm dia. A-Si) cleaning: by blade
Developing assembly	developing cylinder (24.5-mm dia.) developing method: dry, 1-component toner projection toner: magnetic negative toner
Pre-exposure	LED array on/off control
Potential sensor	potential control [1] sets primary current [2] sets laser output [3] sets developing bias (DC)
wire auto cleaning	[1] primary charging wire [2] pre-transfer charging wire [3] transfer charging wire [4] separation charging wire
Primary charging control	DC constant current control: set by result of potential control
Grid bias control	fixed voltage control; fixed by varistor
Developing bias control	AC constant voltage control: on/off control only DC constant voltage control: set by result of potential control
dust-collecting roller bias control	DC non-control
pre-transfer charging control	AC constant voltage control: fuzzy control by environment sensor DC constant current control: on/off only
Transfer charging control	DC constant current control: fuzzy control by environment sensor
Separation charging control	AC constant voltage control DC constant current control: fuzzy control based on output of environment sensor and drum surface potential

### 7.1.2 Major Components

iR5065 / iR 5055 / iR5075 / iR5075N / iR5065N / iR5055N

The following shows the major components of the machine's image formation system:

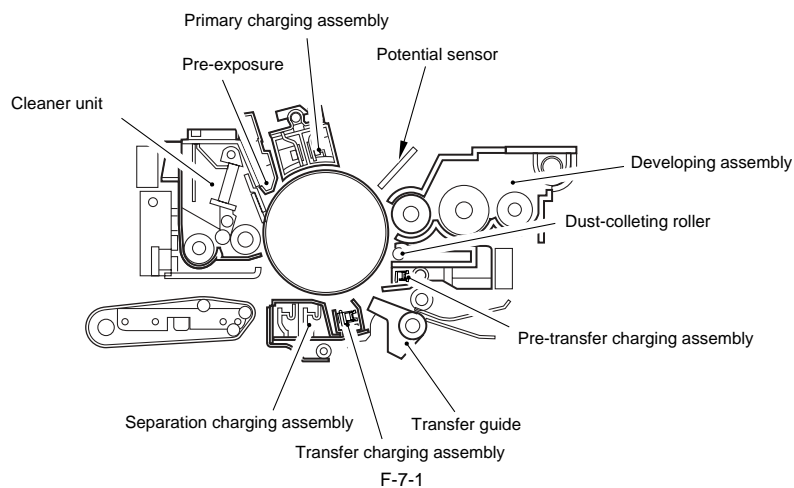

## 7.2 Image Formation Process

### 7.2.1 Overview

iR5065 / iR 5055 / iR5075 / iR5075N / iR5065N / iR5055N

The machine's image formation process consists of the following 8 steps:

T-7-2

- step 1 pre-exposure
- step 2 primary charging (positive DC)
- step 3 laser exposure\*
- step 4 development (AC + positive DC)
- step 5 transfer (negative DC)
- step 6 separation (AC + positive DC)
- step 7 fixing
- step 8 drum cleaning

\*Toner is deposited. The machine also executes black exposure using its laser unit.

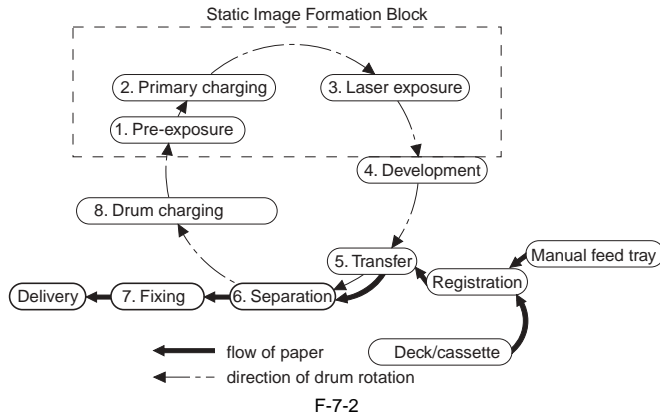

### 7.3 Basic Sequence

#### 7.3.1 At Power-On

iR5065 / iR 5055 / iR5075 / iR5075N / iR5065N / iR5055N

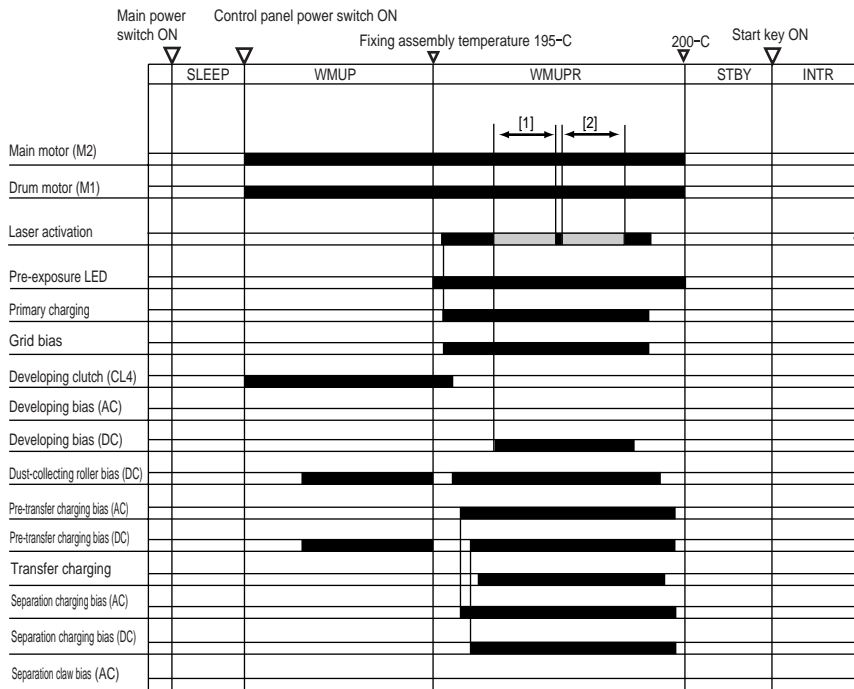

The sequence of operation is as follows:

- [1] The machine executes copier potential control.
- [2] The machine executes printer potential control.

### 7.3.2 At Time of Printing

iR5065 / iR 5055 / iR5075 / iR5075N / iR5065N / iR5055N

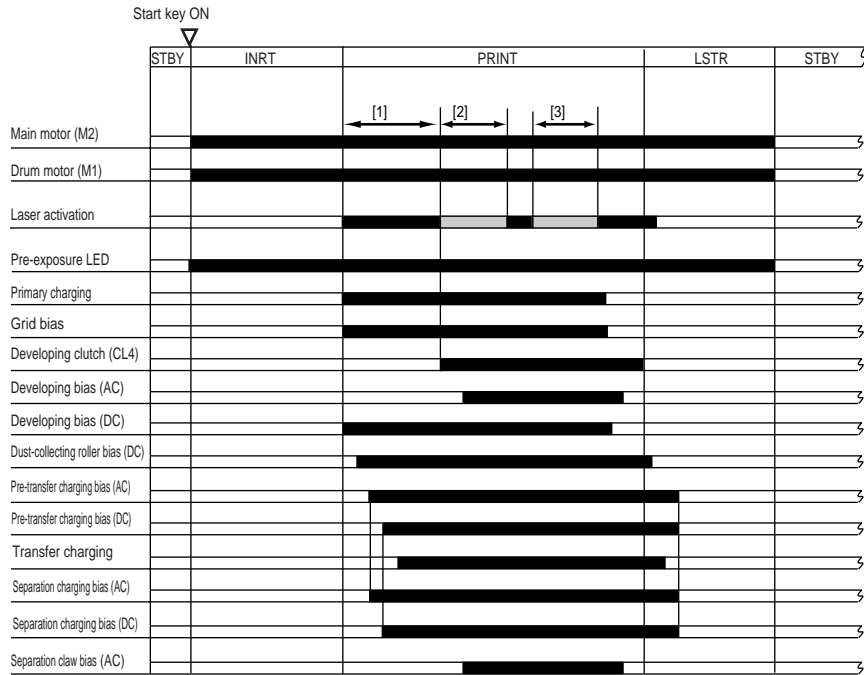

F-7-4

The following shows the sequence of operation:

- [1] The machine executes a series of charging operations prior to an image formation session, thus stabilizing the potential of the drum.
- [2] The machine executes image formation 1.
- [3] The machine executes image formation 2.

## 7.4 Potential Control

### 7.4.1 Overview

iR5065 / iR 5055 / iR5075 / iR5075N / iR5065N / iR5055N

The machine uses the following functions and control mechanisms associated with its potential control system:

1. copier/printer potential control
2. APC (auto power control) correction
3. primary current determination (VD control)
4. laser output determination (VL control)
5. post-laser illumination potential measurement (VDC control)

The following shows the construction of the machine's control system associated with potential control:

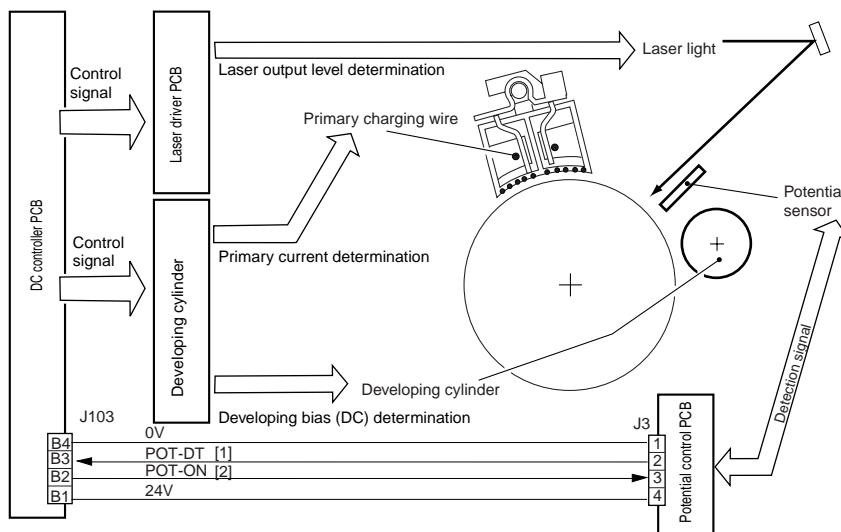

F-7-5

The following signals are associated with potential control:

- [1] POT-DT, drum surface potential measurement
- [2] POT-ON, if '1', turns on the potential sensor

### 7.4.2 Copier/Printer Potential Control

iR5065 / iR 5055 / iR5075 / iR5075N / iR5065N / iR5055N

**A. Timing and particulars of potential control**

**1. At the time of warm-up**

The machine's potential control consists of copier potential control mechanisms and printer potential control mechanisms. The machine uses VD=390V for both copier and printer control mechanisms. The timing of potential control is as follows:

T-7-3

**At time of warm-up**

Purpose	to execute potential control for copier/printer mode  to determine a constant value for copier/printer mode
Operating condition	- the temperature of the fixing assembly is 50 deg C or lower when the main power switch is on - when the first image is being formed 60 min after warm-up
Operation length	10 sec (approx.)
Service mode	may be enabled or disabled using the following: COPIER>OPTION>BODY>PO-CNT
Default	ON (potential control for both copier and printer modes)

**2. In the service mode**

If enabled in service mode, potential control starts 10 min and 60 min after the main power switch is turned on or when the door is opened and closed. The timing and particulars of potential control are as follows:

T-7-4

**10 min and 60 min after the main power switch is turned on**

Purpose	to control sensitivity, thus making up for changes in drum temperature to accommodate changes in charging efficiency
Operating conditions	- start of the 1st job 10 min and 60 min after the main power switch has been turned on - the door is opened and closed
Operation length	off: is not executed (default)  short mode: about 5 sec  standard mode: about 10 sec
service mode	settings may be OFF, short, or standard as determined by the following: COPIER>OPTION>BODY>PO-CNTMD
Default	OFF

**B. Sequence of potential control**

**1. At the time of warm-up**

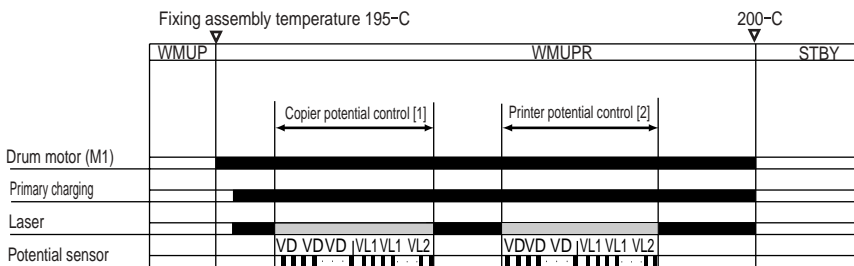

F-7-6

The sequence and particulars of potential control are as follows:

- [1] copier potential control: VD = 8 times max.; VL1 = 8 times max.; VL2 = once
- [2] printer potential control: VD = 8 times max.; VL1 = 8 times max.; VL2 = once

**SERVICE MODE:**

**COPIER>OPTION>BODY>PO-CNT (enable/disable potential control)**

0: disable potential control  
1: enable potential control

**2. In the service mode**

The following settings may be made for potential control executed 10 min and 60 min after the main power switch is turned on and when the door is opened and closed: COPIER>OPTION>BODY>PO-CNTMD:

- [1] off (default): disable potential control  
[2] short mode: decrease the length based on potential attained by executing either of the 2 modes  
[3] standard mode: execute both copier and printer potential control in succession

**a. Short Mode**

The machine executes one of the 2 potential modes, and makes an assumption for the other mode.

For warm-up after power-on, the machine refers to the primary current level, laser output level, and developing bias DC level for both copier potential control and printer potential control, thereby computing and saving the resulting rate.

In the course of potential control after power-on, the machine executes one of the 2 potential control modes, thus computing the other in relation to the rate it obtained at time of power-on and after power-on.

The following is the sequence of operation used for short mode:

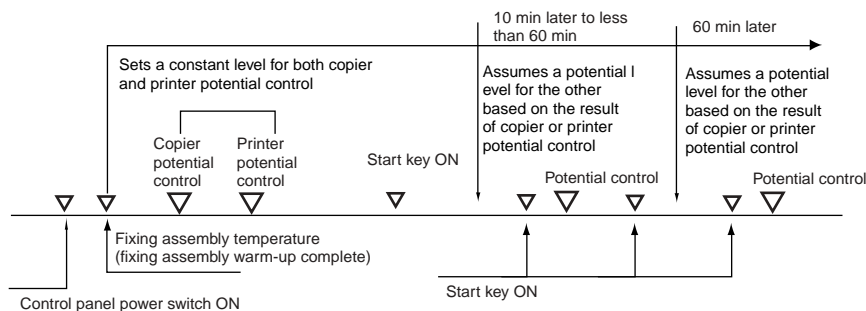
**b. Standard Mode**

The machine executes both copier potential control and printer potential control in succession.

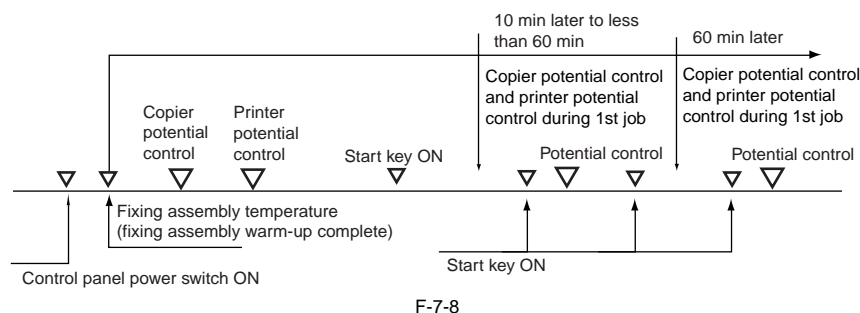

In addition to standard mode and short mode, the machine also offers 30-sec mode executed for 30-sec start-up.

**c. 30-sec Mode**

The machine executes 30-sec mode in a power save state and when it is turned on for the first time for the day.

The machine uses the value of the previous control session to initiate laser exposure, measuring the post-laser illumination potential (VLM) and determining the developing bias DC (Vdc).

**SERVICE MODE:****COPIER> OPTION> BODY> PO-CNT (turning off the potential control mechanism)**

0: disable potential control  
1: enable potential control (default)

**COPIER> OPTION> BODY> PO-CNTMD (selecting potential control mode)**

0: 10 min, 60 min potential control OFF (default)  
1: 10 min, 60 min short mode  
2: 10 min, 60 min normal mode

**COPIER> OPTION> TEMPO> F-POT-SW**

Enter '1' if a transfer separation fault occurs because of a fault in the potential sensor (as a tentative remedy until the replacement of the sensor).

**COPIER> OPTION> TEMPO> F-POT-D**

Enabled when '1' is set for the following: COPIER>OPTION>TEMPO>F-POT-SW.

0: if user primarily uses originals with low image ratio (text original; default)  
1: if user primarily uses originals with high image ratio (photo original)  
2: if re-transfer (drop-out at 50 mm of leading edge) occurs

**COPIER> OPTION> TEMPO> F-HUM-SW**

Enter '1' if the environment sensor is faulty (as a tentative remedy until replacement of the sensor).

**COPIER> OPTION> TEMPO> F-HUM-D**

Enabled if '1' is set for the following: COPIER>OPTION>TEMPO>F-HUM-SW.

Enter the humidity reading of the site of installation (between 30% and 99%; default being 35%).

**COPIER> FUNCTION> DPC> DPC (forcing potential control)**

ON: execute potential control

**COPIER> ADJUST> V-CONT> EPOTOFST (setting potential sensor offset value)****COPIER> ADJUST> V-CONT> DE-OFST (adjusting copy Vdc)****COPIER> ADJUST> V-CONT> VD-OFST (setting copy VD target potential offset value)****COPIER> ADJUST> V-CONT> DE-OFS-P (adjusting printer Vdc)****COPIER> ADJUST> V-CONT> VD-OFS-P (setting printer VD target potential offset value)**

Enter the value indicated on the service label if you have initialized the RAM on the DC controller PCB.

**COPIER> FUNCTION> DPC>OFST** (adjusting potential sensor offset)  
 For the method of adjustment, see "Standards and Adjustments."

### 7.4.3 Determining the Primary Current

iR5065 / iR 5055 / iR5075 / iR5075N / iR5065N / iR5055N

To measure the dark area potential (VD) for the first time after the power switch is turned on, the machine uses the most recently measured current level, and measures the drum surface potential using the potential sensor. The DC controller PCB compares the drum surface potential and the target potential; as a result, if the measured potential is +/-6 V of the target value, the machine corrects the primary current and measures the potential once again. The machine executes potential measurement a maximum of 8 times, and also corrects the primary current as many times.

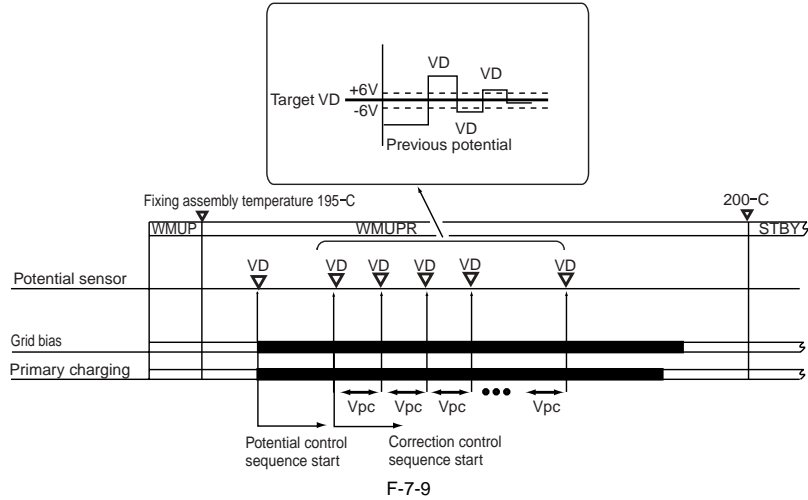

### 7.4.4 Determining the Laser Output

iR5065 / iR 5055 / iR5075 / iR5075N / iR5065N / iR5055N

To measure the light area potential (VL1) for the first time after the power switch is turned on, the machine uses the most recent laser output level (LP0), and measures the drum surface potential using the potential sensor. The DC controller PCB compares the drum source potential and the target potential; if the measured potential is +/-10V of the target value, the machine corrects the potential of the laser output, and measures the potential once again. The machine executes potential measurement a maximum of 8 times, and also corrects the lower output level as many times. In addition, the machine measures the light area (VL2) for the developing bias for use in determining the laser output (LP) needed to attain the target potential.

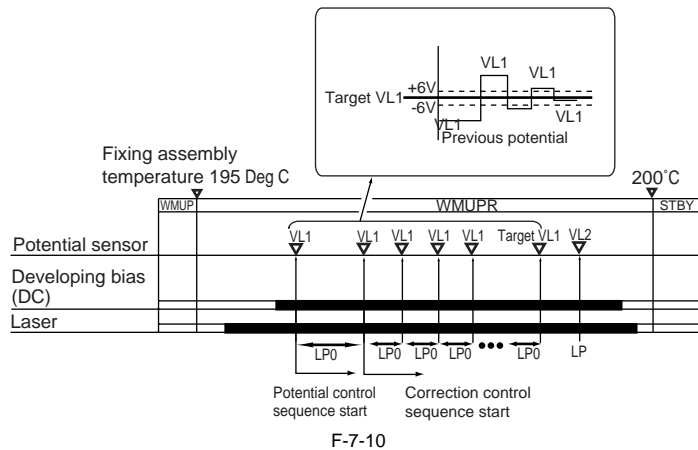

### 7.4.5 Determining the Developing Bias

iR5065 / iR 5055 / iR5075 / iR5075N / iR5065N / iR5055N

The machine determines the developing bias (VDC) as follows with reference to the drum surface potential (VL2):  
 $VDC = VL2 + \text{delta } VDC$

For copier potential, delta VDC=110 V

For printer potential, delta VDC=85 to 110 V (i.e., the printer potential varies to suit the reading of the environment sensor, thus ensuring the reproduction of correct line width)

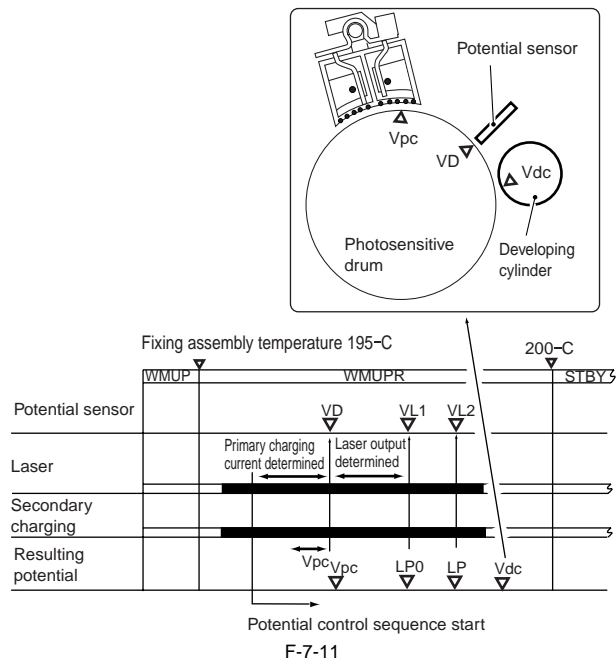

### 7.4.6 APC Correction

iR5065 / iR 5055 / iR5075 / iR5075N / iR5065N / iR5055N

Changes in the laser output cause changes in the surface potential. To maintain a specific level of surface potential, the machine corrects the laser output control value. The following shows the type and the particulars of laser output control value correction:

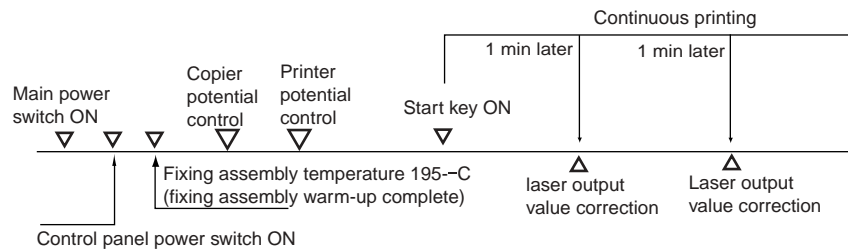

#### (1) Between-Sheet APC Control

Purpose: to maintain a specific level of surface potential without lowering the productivity during a continuous job; the machine measures the potential after laser output between sheets, and corrects the laser output control value.

Timing: over the 1st interval between sheets every 1 min after the start of a continuous print job.

Potential measurement: the drum potential varies in drum peripheral direction; thus, the machine computes the average drum surface potential in drum peripheral direction. It uses the result of computation to determine the laser output correction value. If measurement is not possible because of conditions imposed by the need for measurement between sheets, the machine will continue measurement for an additional 1 min.

#### (2) Initial Rotation APC Control

Purpose: to make up for the changes in the VL potential of the laser output occurring after an appreciable time, the machine measures the drum potential and corrects the laser output control value.

Timing: during initial rotation of the 1st job 60 min after the end of a job.

Potential measurement: the drum potential varies in peripheral direction, and the machine computes the average drum potential in peripheral direction. The machine uses the result of computation to obtain the appropriate laser output correction value.

#### (3) Last Rotation APC Control

Purpose: when intermittent printing is repeated at short intervals, the absence of potential control can cause changes in the VL potential of the laser output. To make up for the changes, the machine computes a correction value for the laser output control value and uses the result for the next job.

Timing: during last rotation for the 1st job 30 min after the most recent laser output correction.

Potential measurement: the drum potential varies in peripheral direction. The machine computes the average drum potential in peripheral direction, and obtains the appropriate laser output correction value using the result of computation.

### SERVICE MODE:

#### COPIER>OPTION>BODY>LAPS-SW (switching laser correction)

0: ON (left alone for 10 min -> initial rotation APC)

1: ON (left alone for 60 min -> initial rotation APC; default)

2: ON (left alone for 120 min -> initial rotation APC)

3: OFF only for initial rotation APC

4: OFF

### 7.4.7 Adjusting the Density in Various Modes

iR5065 / iR 5055 / iR5075 / iR5075N / iR5065N / iR5055N

The machine corrects the development bias determined as a result of potential control for the following operating modes, and uses the result as the target value for the individual modes:

**1. Adjusting the Density for Copying**

The machine increases the developing bias to decrease the copy density. If increased in excess, the bias can cause light images; if decreased in excess, on the other hand, the background can develop fogging. In light of this, the machine executes density processing using changes in the developing bias and image processing (binary density processing).

Purpose: to obtain the density suited to the user's needs.

Method of correction: uses the developing bias and image processing (binary density processing) according to the F-value setting.

T-7-5

F value	Developing DC bias standard value (V)	Shift (V)	Image processing	Image density
1	240	60	yes	lighter
2	220	40	no	
3	180	0	no	
4	140	-40	no	
5	120	-60	yes	

**2. Adjusting the Density for Printing**

The machine increases the developing bias to increase the print density. If increased in excess, the background can develop fogging. At the lower limit of the developing bias, the machine uses the changes in the developing bias and image processing (thickening processing) to ensure appropriate density.

Purpose: to obtain the density suited to the user's needs.

Method of correction: uses the developing bias and image processing (thickening) to suit the F-value setting.

T-7-6

F value	Developing DC bias standard value (V)	Shift (V)	Thickening*1	Image density	
1	218	48	no	light	
2	205	35	no		
3	194	24	no		
4	182	12	no		
5	170	0	no		
6	153	-17	no		
7	137	-33	no		
8	120	-50	no		
9	120	-50	yes		dark

\*1: Thickening processing may be enabled for all F values in user mode ('correct fine line').

**7.5 Charging Mechanism**

**7.5.1 Controlling Pre-Exposure LED**

**7.5.1.1 Pre-Exposure LED Control**

iR5065 / iR 5055 / iR5075 / iR5075N / iR5065N / iR5055N

The machine is equipped with a pre-exposure LED used to prevent adhesion of excess toner on the photosensitive drum because of residual charges. The following is an item associated with the pre-exposure LED control system:

**1. turning on/off the pre-exposure LED**



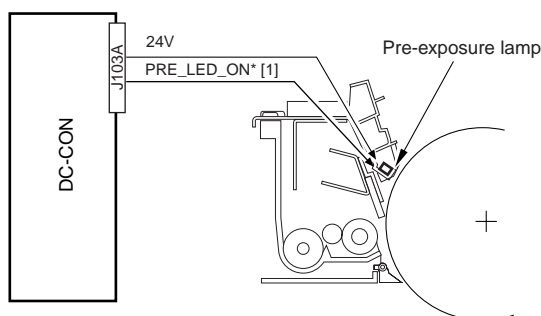

F-7-13

The following is the signal associated with the mechanism:  
 [1] Pre-exposure LED control signal; when '0', LED goes on

## 7.5.2 Primary Charging Mechanism

### 7.5.2.1 Overview

iR5065 / iR 5055 / iR5075 / iR5075N / iR5065N / iR5055N

The following items are associated with the primary charging control system:

1. turning on/off the primary corona current
2. controlling the constant current level of the primary corona current
3. controlling the constant voltage level of the grid bias (fixed to 850 V by a valista)

The following shows the construction of the control system associated with the primary charging control system:

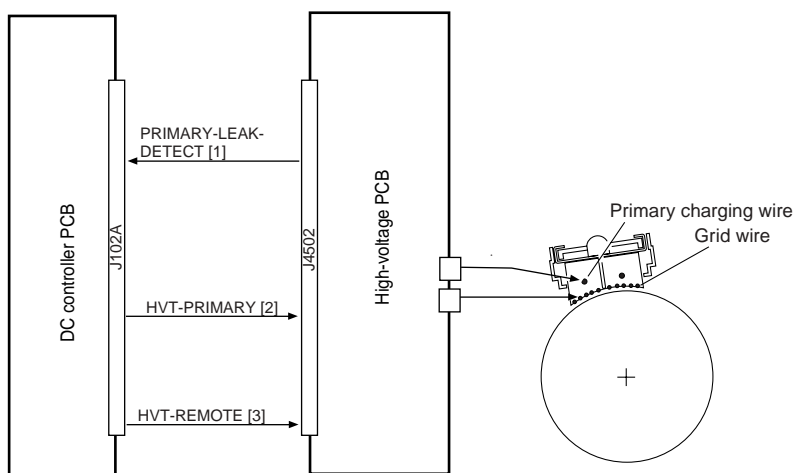

F-7-14

The following signals are associated with the mechanism:

- [1] Primary charging leakage detection signal; when '0', if the current is too high or too low
- [2] Primary corona current control signal; used to control the primary charging current generated by the high-voltage PCB
- [3] High-voltage remote signal; turning on/off the primary charging corona current output

### 7.5.2.2 Primary Charging Assembly Cleaning Mechanism

iR5065 / iR 5055 / iR5075 / iR5075N / iR5065N / iR5055N

The primary charging wire cleaning mechanism is turned on at the following timing, and the construction of the control system is as shown:

Timing of Cleaning

- when the wire cleaning mechanism is executed in user mode
- when the wire cleaning mechanism is executed in service mode:  
   COPIER>FUNCTION>CLEANING>WIRE-CLN\*1
- after the end of cleaning, at the end of every 2,000 prints\*2
- in a low temperature or high humidity environment, if the fixing roller is 160 deg C or less when the power is turned on

\*1: The machine executes it when the primary charging wire or the transfer charging wire has been replaced.

\*2: The default cleaning interval may be changed in service mode (COPIER> OPTION> BODY> W-CLN-P).

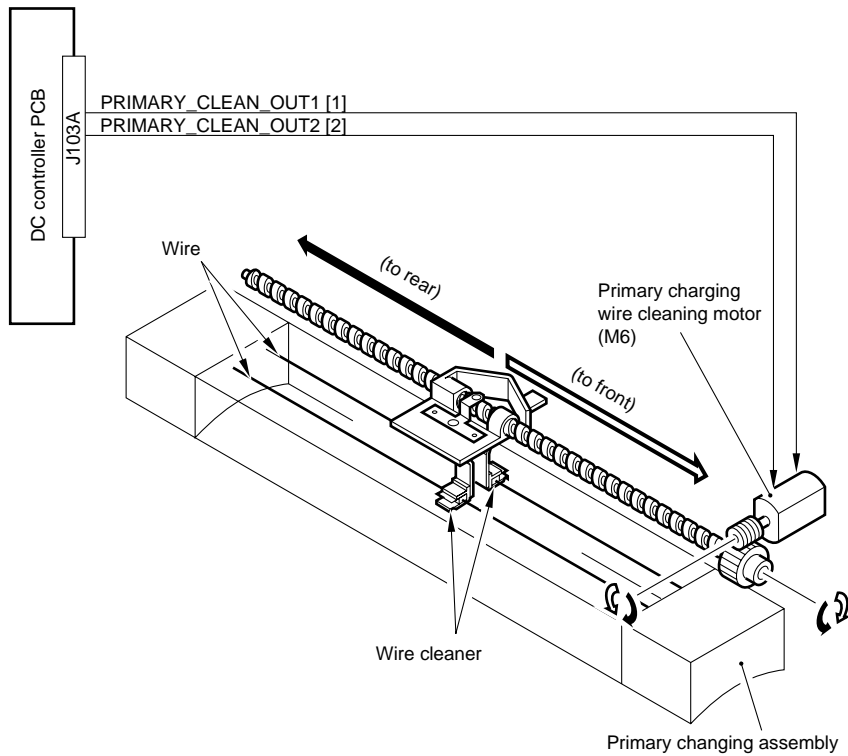

F-7-15

The following signals are associated with the mechanism:

[1] Primary charging wire cleaning motor reverse direction signal; when '1', the wire cleaner moves toward the rear.

[2] Primary changing wire cleaning motor normal direction signal; when '1', the wire cleaner moves toward the front.

[1] 1éüë—ìdè`èYè|ÉÇÀ|É^ati|ãñÆèMçÛ1: "1" ÇYÉèÉCÉÑÉÑÉäÄ|ÉjCOáúí°ä Ç...àìÆ

[2] 1éüë—ìdè`èYè|ÉÇÀ|É^èSì|ãñÆèMçÛ2: "1" ÇYÉèÉCÉÑÉÑÉäÄ|ÉiÇÖèÉèOr°ä Ç...àìÆ

### 7.5.2.3 Others

iR5065 / iR 5055 / iR5075 / iR5075N / iR5065N / iR5055N

#### SERVICE MODE:

##### COPIER>FUNCTION>CLEANING>WIRE-CLN

Use it so that the machine causes the wire cleaner to make 5 round trips to automatically clean the charging wire when the primary charging wire or the transfer wire has been replaced.

##### COPIER>OPTION>BODY>W-CLN-P

Use it to specify the interval at which the primary charging wire is automatically cleaned in terms of the number of prints made.

### 7.5.3 Dust-Collecting Roller Bias

#### 7.5.3.1 Overview

iR5065 / iR 5055 / iR5075 / iR5075N / iR5065N / iR5055N

The machine is equipped with a dust-colleting roller to collect stray toner occurring after development. The toner collected on its surface is removed by the work of a scraper.

The following item is associated with the dust-colleting roller bias control system:

1. turning on/off the dust-colleting roller bias

The following shows the construction of the dust-colleting roller bias:

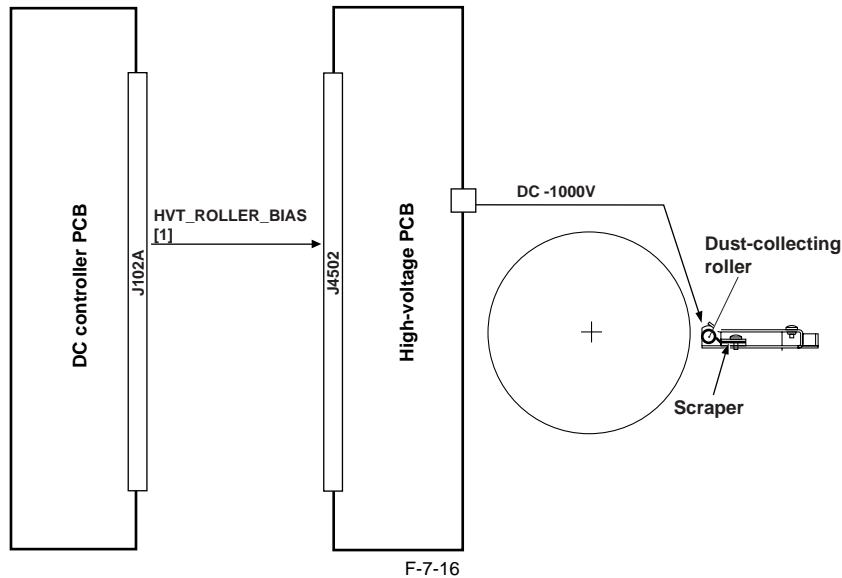

The following signal is associated with the mechanism:  
 [1] dust-collecting roller bias remote signal; if '1', the dust-collecting roller bias turns on.

**7.5.4 Pre-Transfer Charging Mechanism**

**7.5.4.1 Overview**

iR5065 / iR 5055 / iR5075 / iR5075N / iR5065N / iR5055N

The following items are associated with the pre-transfer charging control system:

1. controlling the constant current level of the DC bias
2. controlling the fixed voltage level of the AC bias
3. controlling the output to suit the environment (fuzzy control)

The following shows the construction of the system associated with the pre-transfer charging control mechanisms:

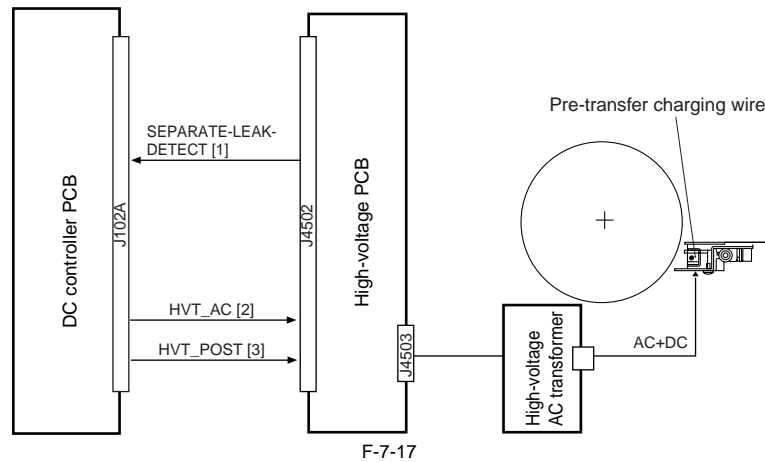

The following signals are associated with the mechanism:  
 [1] Pre-transfer/separation charging leakage detection signal; when the current is too high or too low, '0'.  
 [2] Pre-transfer charging control signal; controls the DC bias current and AC bias voltage generated by the high-voltage PCB.  
 [3] Pre-transfer/separation charging remote signal; turns on/off the pre-transfer/separation current output.

**7.5.4.2 Controlling the Output to Suit the Environment (fuzzy control)**

iR5065 / iR 5055 / iR5075 / iR5075N / iR5065N / iR5055N

The pre-transfer charging current is optimized to suit the environment (i.e., reading of the environment sensor):

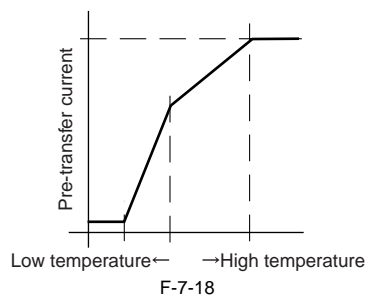

**COPIER>OPTION>BODY>FUZZY (turning on/off fuzzy control)**

0: enable fuzzy control (default)

1: low humidity mode (for pre-transfer charging current level lower than standard)

2: normal humidity mode

3: high humidity mode (for pre-transfer charging current higher than standard)

When set to '1' through '3', the machine executes the appropriate modes independently of the reading of the environment sensor.

**7.5.4.3 Pre-Transfer Charging Assembly Cleaning Mechanism**

iR5065 / iR 5055 / iR5075 / iR5075N / iR5065N / iR5055N

The machine executes pre-transfer charging wire cleaning as follows using its associated mechanism:

**Timing**

1. when wire cleaning is executed in user mode.

2. when wire cleaning is executed in service mode (COPIER&gt;FUNCTION&gt;CLEANING&gt;WIRE-CLN)\*1.

3. after the end of cleaning, every 2,000 prints\*2.

4. in a low temperature or high humidity environment, if the fixing roller is 160 deg C or less when the power is turned on.

\*1: The machine executes cleaning when the primary charging wire or the transfer charging wire has been replaced.

\*2: The default cleaning interval may be changed in service mode: COPIER&gt;OPTION&gt;BODY&gt;W-CLN-P.

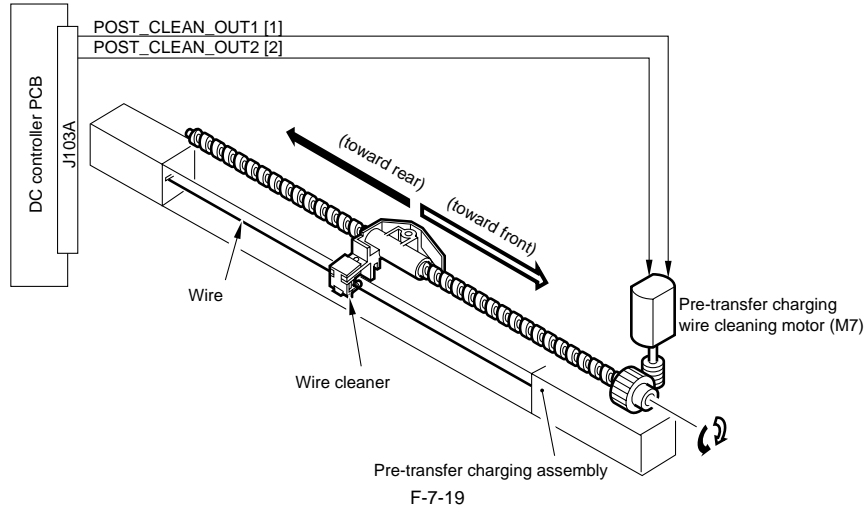

The following signals are associated with the mechanism:

[1] Pre-transfer charging wire cleaning motor normal direction signal; when '1', the wire cleaner moves toward the rear.

[2] Pre-transfer charging wire cleaning motor reverse direction signal, when '1', the wire cleaner moves toward the front.

**7.5.4.4 Others**

iR5065 / iR 5055 / iR5075 / iR5075N / iR5065N / iR5055N

**SERVICE MODE:****COPIER>ADJUST>HV-TR>PRE-TR (entering output adjustment value for pre-transfer charging current)**

Enter the value indicated on the service label if you have initialized the RAM on the DC controller PCB.

**COPIER>ADJUST>HV-TR>H-PRE-TR (entering offset value for pre-transfer high-voltage output of high-voltage unit)**

Enter the value indicated on the label attached to the new high-voltage unit if you have replaced the high-voltage unit or initialized the RAM on the DC controller PCB.

**COPIER>ADJUST>HV-TR>D-PRE-TR (entering offset value for pre-transfer high-voltage output of DC controller PCB)**

Enter the value indicated on the label attached to the new DC controller PCB if you have replaced the DC controller PCB or initialized the RAM on the DC controller PCB.

**COPIER>OPTION>BODY>W-CLN-P**

Use it to set the interval of automatic cleaning of the pre-transfer charging wire in terms of the number of prints.

**7.6 Drum Cleaner Unit****7.6.1 Overview**

iR5065 / iR 5055 / iR5075 / iR5075N / iR5065N / iR5055N

The following shows the components found in the drum cleaner unit:

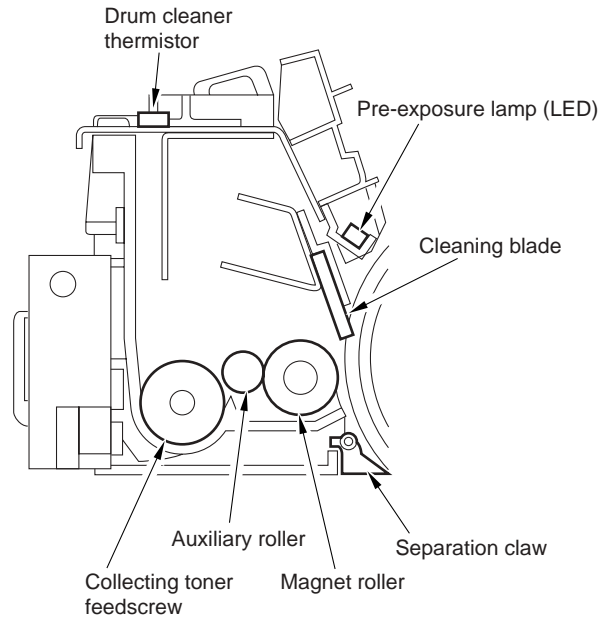

F-7-20

### 7.6.2 Detecting the State (full) of the Collecting Toner Case

iR5065 / iR 5055 / iR5075 / iR5075N / iR5065N / iR5055N

The following shows the control mechanism used to see if the collecting toner case has become full:

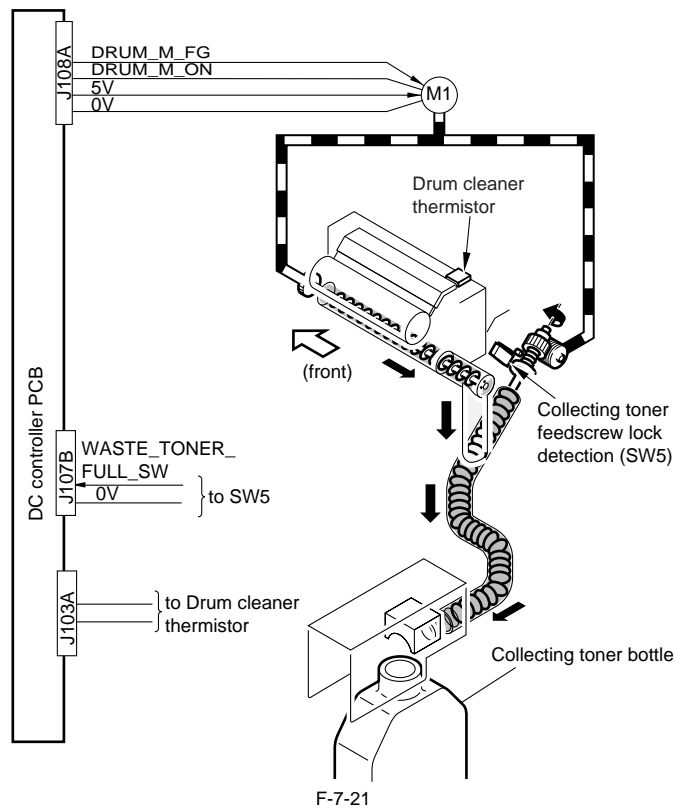

F-7-21

#### ERROR CODE:

##### E013-0001

Indicated if the collecting toner feedscrew sensor (MSW2) has remained on for 5 sec or more.

##### E821-0001

The reading of the drum cleaner thermistor is 55 deg C at least once, causing the machine to assume that the inside of the cleaner is clogged with toner.

#### SERVICE MODE:

##### COPIER>COUNTER>MISC>WASTE-TNR

collecting toner counter; when its reading reaches '250,000', the machine will issue an alarm on the User screen.

Dispose of the collecting toner, and reset the error code.

#### MEMO:

The collecting toner bottle can hold toner good for a maximum of 500,000 prints. The machine will indicate a collecting toner bottle full alarm when the counter

reading reaches '250,000'.

### 7.6.3 Drum/Separation Claw Bias Control

iR5065 / iR 5055 / iR5075 / iR5075N / iR5065N / iR5055N

Since the separation claw contacts the drum, toner caught by the separation claw can fall in the feeder path as the machine is getting aged. Such events can cause the soiled back or faulty images.

As a countermeasure, the machine supplies the AC bias voltage (Vpp430V) to the separation claw, which generates vibration to prevent the toner from accumulating in the separation claw.

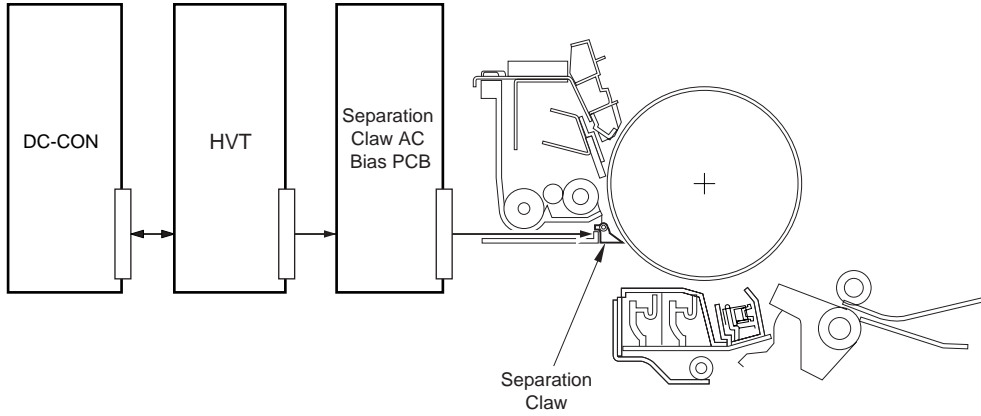

F-7-22

## 7.7 Developing Assembly

### 7.7.1 Controlling the Developing Assembly Drive

iR5065 / iR 5055 / iR5075 / iR5075N / iR5065N / iR5055N

The following shows the construction of the developing assembly drive control system:

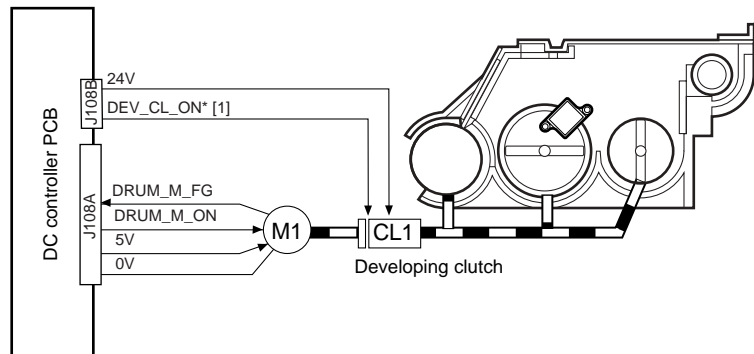

F-7-23

The following signal is associated with the developing assembly control mechanism:

- [1] Developing clutch drive signal; when '0', the drive of the main motor (M1) is transmitted to the developing assembly.

### 7.7.2 Controlling the Developing Bias

iR5065 / iR 5055 / iR5075 / iR5075N / iR5065N / iR5055N

The following items are associated with the developing bias control system:

- [1] Controlling the DC bias constant voltage
- [2] Controlling the AC bias constant voltage

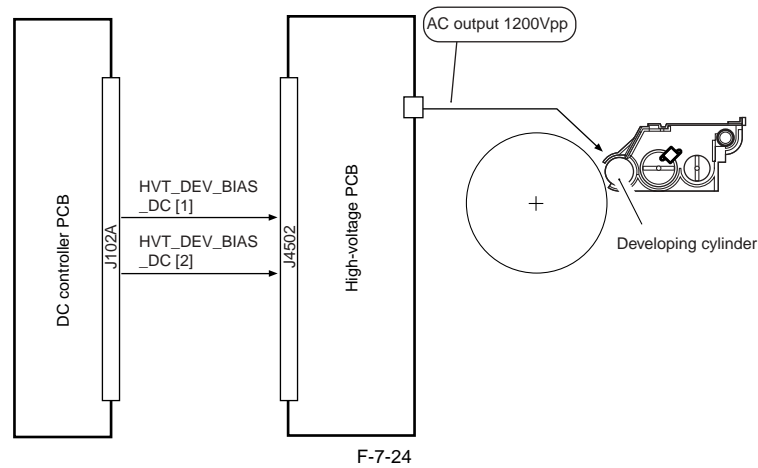

The following signals are used in association with the developing bias control mechanism:

- [1] Developing DC bias current control signal; controls the DC component of the developing bias generated by the high-voltage power supply PCB.  
 [2] turns on/off the developing bias current output.

#### SERVICE MODE:

##### COPIER>ADJUST>DEVELOP>BIAS

(entering developing bias)

Enter the value indicated on the service label if you have initialized the DC controller PCB.

setting range: 0 (darker) to 600 (lighter)

##### COPIER>ADJUST>DEVELOP>HVT-DE

(entering offset value for developing high-voltage output of high-voltage unit)

Enter the value indicated on the label attached to the new high-voltage unit if you have replaced the DC controller PCB or initialized the RAM on the DC controller PCB.

setting range: -100 (lighter) to +100 (darker)

##### COPIER>ADJUST>DEVELOP>D-HV-DE

(entering offset value for developing high-voltage output of DC controller PCB)

Enter the value indicated on the label attached to the DC controller PCB if you have replaced the DC controller PCB or initialized the RAM on the DC controller PCB.

setting range: -100 (lighter) to +100 (darker)

##### COPIER>ADJUST>V-CONT>DE-OFST

(adjusting VDC for copier)

##### COPIER>ADJUST>V-CONT>DE-OFS-P

(adjusting VDC for printer)

Enter the value indicated on the service label if you have initialized the RAM on the DC control PCB.

### 7.7.3 Detecting the Toner Level and Controlling Toner Supply

iR5065 / iR 5055 / iR5075 / iR5075N / iR5065N / iR5055N

The following shows the components associated with the toner supply control system:

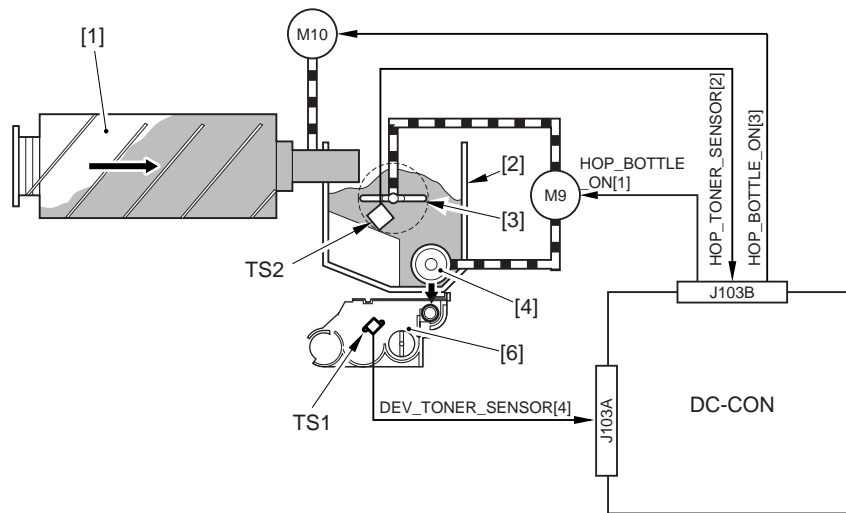

- [1] Toner bottle  
 [2] Hopper assembly  
 [3] Toner stirring plate  
 [4] Toner feedscrew  
 [5] Toner feed pipe  
 [6] Developing assembly  
 M9: Hopper stirring motor  
 M10: Toner supply motor  
 TS1: Developing assembly toner level sensor  
 TS2: Inside hopper toner level sensor  
 DC-CON: DC controller (components used to detect level of remaining toner)

**Toner Supply Sequence**

The toner inside the developing assembly is monitored by the developing assembly toner level sensor (TS1); when the toner inside the developing assembly falls below a specific level, the developing assembly toner level signal goes '0' so that the DC controller PCB recognizes it. If the DC controller PCB detects the developing assembly toner level signal for 0.3 sec or more, it generates the hopper motor drive signal so that the hopper assembly will start supplying toner. When the toner inside the developing assembly reaches a specific level and, as a result, the developing assembly toner level signal remains '1' for 0.7 sec or more, the hopper supply motor stops. When the toner inside the hopper drops below a specific level, the hopper toner level detection signal goes '0'. If the signal remains '0' when the toner supply motor has been turned on and off 20 times after the detection of the signal state by the DC controller, the machine issues a message of bottle exchange. Total rotating time reaches 60 seconds after the toner sensor in the developing assembly senses no toner, the machine issues a method of exchanging bottles and stops the ongoing printing operation. When the toner bottle is replaced, the hopper supply motor and the stirring motor are turned on, and the developing assembly inside toner level detection signal goes '1', the machine resets the message of bottle exchange and resumes printing.

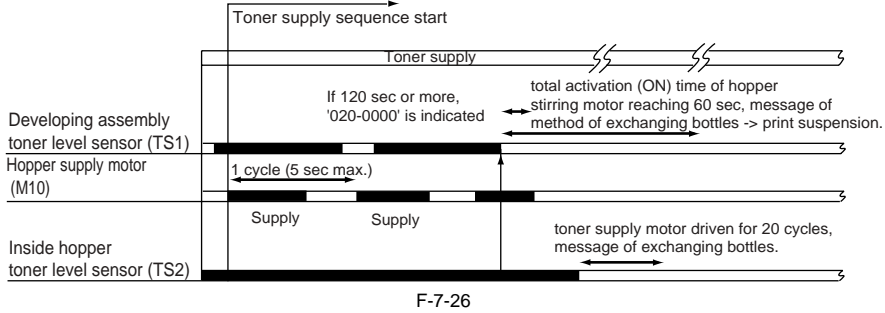

F-7-26

**ERROR CODE:**

**E020-0000**

Indicated while the output of the inside hopper toner level sensor (TS2) points to the presence of toner and the output of the developing assembly toner level sensor (TS1) inside the developing assembly points to the absence of toner for 120 sec or more.

**7.8 Transfer Mechanism**

**7.8.1 Transfer Charging Mechanism**

**7.8.1.1 Overview**

iR5065 / iR 5055 / iR5075 / iR5075N / iR5065N / iR5055N

The following items are associated with the transfer charging control system:

1. controlling the DC bias constant current
2. controlling the output to suit the environment (fuzzy control)

The following shows the construction of the transfer charging control system:

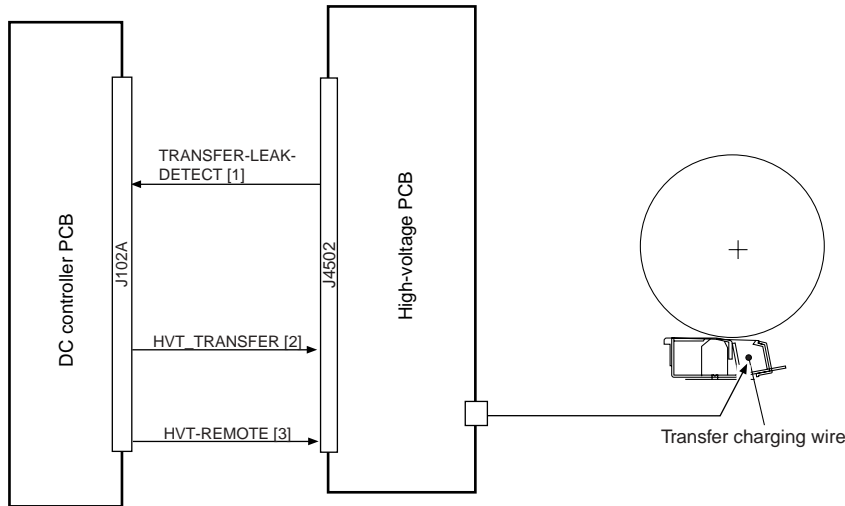

F-7-27

The following signals are associated with the transfer charging control mechanism:

- [1] Transfer charging leakage detection signal; when the current is too high or too low, '0'
- [2] Transfer charging current control signal; used to control the transfer current generated by the high-voltage PCB
- [3] High-voltage remote signal; turns on/off the transfer current output

**7.8.1.2 Controlling the Output to Suit the Environment (fuzzy control)**

iR5065 / iR 5055 / iR5075 / iR5075N / iR5065N / iR5055N

The transfer charging current is optimized to suit the environment (i.e., reading of the environment sensor).

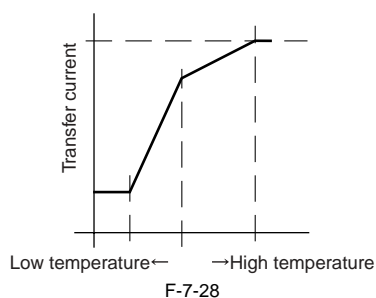

**SERVICE MODE:****COPIER>OPTION>BODY>FUZZY (turning on/off fuzzy control)**

0: turns off fuzzy control (default)

1: low humidity mode (for lower transfer charging current than standard)

2: normal humidity mode

3: high humidity mode (for higher transfer charging current than normal)

When set to '1' through '3', the machine executes the appropriate modes independently of the reading of the environment sensor.

**7.8.1.3 Transfer Charging Assembly Cleaning Mechanism**

iR5065 / iR 5055 / iR5075 / iR5075N / iR5065N / iR5055N

The following shows the timing at which transfer charging wire cleaning is executed and the construction of the associated system:

**Timing**

1. when wire cleaning is executed in user mode
  2. when wire cleaning is executed in service mode (COPIER> FUNCTION> CLEANING> WIRE-CLN)\*1
  3. at the end of every 2,000 prints after the end of cleaning\*2
  4. if the fixing roller is 160 deg C or less in a low temperature or high humidity environment
- \*1: The machine executes wire cleaning when the primary charging wire or the transfer charging wire has been replaced.  
\*2: The default cleaning interval may be adjusted in service mode: COPIER> OPTION> BODY> W-CLN-P.

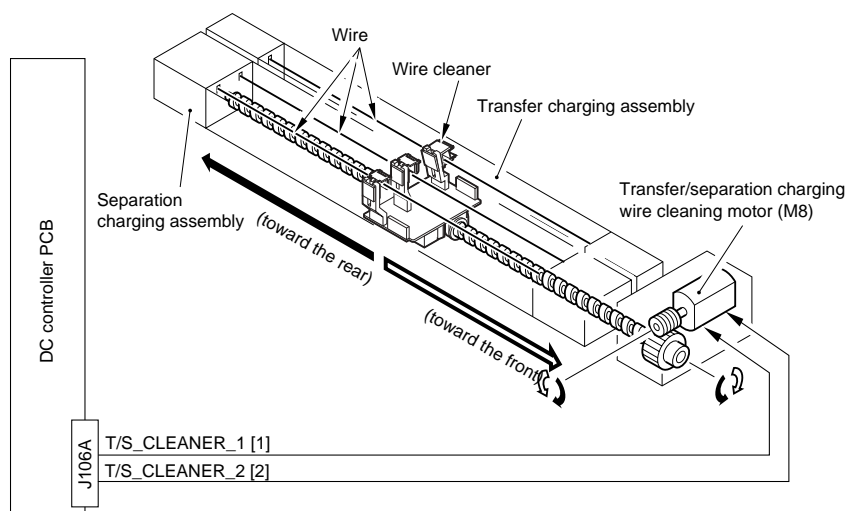

The following signals are used in association with the cleaning mechanism:

- [1] Transfer charging wire cleaning motor normal direction signal; when '1', the wire cleaner moves toward the rear.  
[2] Transfer charging wire cleaning motor reverse direction signal; when '1', the wire cleaner moves toward the front.

**7.8.1.4 Others**

iR5065 / iR 5055 / iR5075 / iR5075N / iR5065N / iR5055N

**SERVICE MODE:****COPIER> ADJUST> HV-TR> TR-N1**

(adjusting the transfer charging current output for the 1st side of a duplex print or for a simplex print using plain paper)

**COPIER> ADJUST> HV-TR> TR-N2**

(adjusting the transfer charging current output for the 2nd side of a duplex print using plain paper)

**COPIER> ADJUST> HV-TR> HVT-TR**

(entering the offset value of the transfer high-voltage output of the high-voltage unit)

Enter the value indicated on the label attached to the new high-voltage unit if you have replaced the high-voltage unit or initialized the RAM on the DC controller PCB.

**COPIER> ADJUST> HV-TR> D-HV-TR**

(entering the offset value for the transfer high-voltage output of the DC controller PCB)

Enter the value indicated on the label attached to the new DC controller PCB if you have replaced the DC controller PCB or initialized the RAM on the DC controller PCB.

**COPIER> FUNCTION> CLEANING> WIRE-CLN**

Use it so that the machine automatically causes its wire cleaner to make 5 round trips if you have replaced the primary charging wire or the transfer charging wire.

**COPIER> OPTION> BODY> W-CLN-P**

Use it to set the interval of automatically cleaning the pre-transfer charging wire in terms of the number of prints.

**COPIER> OPTION> BODY> TR-SP-C1**

(switching over the transfer/separation output value for pickup from the right deck)

**COPIER> OPTION> BODY> TR-SP-C2**

(switching over the transfer/separation output value for pickup from the left deck)

**COPIER> OPTION> BODY> TR-SP-C3**

(switching over the transfer/separation output value for pickup from the cassette 4)

**COPIER> OPTION> BODY> TR-SP-C4**

(switching over the transfer/separation output for pickup from the manual feed tray)

**COPIER> OPTION> BODY> TR-SP-MF**

(Use it to switch the transfer/separation output for pickup from the manual feed tray.)

**COPIER> OPTION> BODY> TR-SP-DK**

(switching over the transfer/separation output value for pickup from the side paper deck)

As necessary, switch over the transfer/separation output value for pickup from various sources of paper by way of correcting various faults:

- 0: normal (default)
- 1: prevent re-transfer
- 2: prevent separation fault
- 3: prevent transfer fault

## 7.9 Separation Mechanism

### 7.9.1 Separation Charging Mechanism

#### 7.9.1.1 Overview

iR5065 / iR 5055 / iR5075 / iR5075N / iR5065N / iR5055N

The following items are associated with the separation charging control system:

1. controlling the constant current of the DC bias
2. controlling the constant voltage of the AC bias
3. correcting the output to suit the environment and drum surface potential (fuzzy control)

The following shows the construction of the separation charging control system:

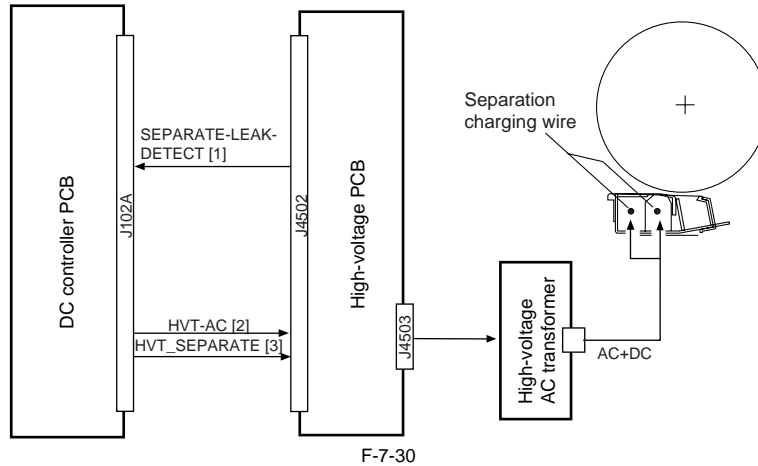

The following signals are associated with the separation charging control mechanisms:

- [1] Separation charging leakage detection signal; if the current is too high or too low, '0'.
- [2] Separation charging current control signal; used to control the DC bias current and the AC bias voltage generated by the high-voltage PCB.
- [3] Separation charging remote signal; turns on/off the separation current output.

#### 7.9.1.2 Correcting the Output to Suit the Environment and the Drum Surface Potential

iR5065 / iR 5055 / iR5075 / iR5075N / iR5065N / iR5055N

The separation current output is optimized to suit the environment (i.e., reading of the environment sensor) and the deposit of toner (either of 3 levels; low, average, high, as determined by the count of black pixels).

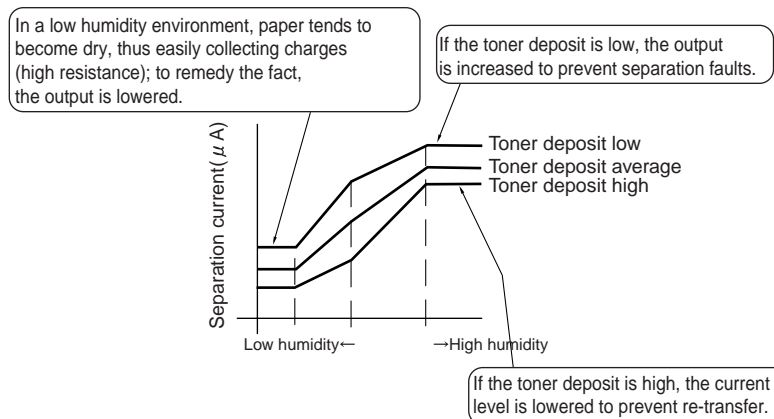

- [1] In a low humidity environment, paper tends to become dry, thus tending to collect charges (high resistance). The output is decreased.
- [2] If the drum surface potential is low, the output is increased to prevent separation faults.
- [3] If the drum surface potential is high, the current level is lowered to prevent re-transfer.

**SERVICE MODE:****COPIER> OPTION> BODY> FUZZY (turning off/on fuzzy control)**

0: enable fuzzy control (default)

- 1: low humidity mode (for higher pre-transfer charging current than normal)
- 2: normal humidity mode
- 3: high humidity mode (for higher pre-transfer charging current than normal)

If '1' through '3' is set, the machine executes the individual modes independently of the reading of the environment sensor.

**7.9.1.3 Others**

iR5065 / iR 5055 / iR5075 / iR5075N / iR5065N / iR5055N

**Service Mode:****COPIER> ADJUST> HV-SP> SP-N1**

(adjusting the output of the 1st side of a duplex print or for a simplex print using plain paper)

**COPIER> ADJUST> HV-SP> SP-N2**

(adjusting the output of the 2nd side of a duplex print using plain paper)

If the RAM on the DC controller PCB has been cleared, enter the value indicated on the service label.

**COPIER> ADJUST> HV-SP> HVT-SP**

(entering the offset value for the separation high-voltage output of the high-voltage unit)

Enter the value indicated on the label attached to the new high-voltage unit if you have replaced the high-voltage unit or initialized the RAM on the DC controller PCB.

**COPIER> ADJUST> HV-SP> D-HV-SP**

(entering the offset value for the separation high-voltage output of the DC controller PCB)

Enter the value indicated on the label attached to the new DC control PCB if you have replaced the DC controller PCB or initialized the RAM on the DC controller PCB.

**COPIER> OPTION> BODY> TR-SP-C1**

(switching over the transfer/separation output value for pickup from the right deck)

**COPIER> OPTION> BODY> TR-SP-C2**

(switching over the transfer/separation output value for pickup from the left deck)

**COPIER> OPTION> BODY> TR-SP-C3**

(switching over the transfer/separation output value for pickup from the cassette 3)

**COPIER> OPTION> BODY> TR-SP-C4**

(switching over the transfer/separation output value for pickup from the manual feed tray)

**COPIER> OPTION> BODY> TR-SP-MF**

(switching over the transfer/separation output value for pickup from the manual feed tray)

**COPIER> OPTION> BODY> TR-SP-DK**

(switching over the transfer/separation output value for pickup from various sources of paper to suit various faults)

The transfer/separation output value is switched for each source of paper to prevent various problems:

0: normal (default)

- 1: prevent re-transfer
- 2: prevent separation
- 3: prevent transfer faults

## 7.10 Parts Replacement Procedure

### 7.10.1 Process Unit

#### 7.10.1.1 Before Removing Process Unit

iR5065 / iR 5055 / iR5075 / iR5075N / iR5065N / iR5055N

- 1) Detach the front cover. (page 10-13)Reference[Removing the Front Cover]
- 2) Detach the toner supply cover. (page 10-14)Reference[Removing the Toner Supply Cover]
- 3) Remove the primary fan duct. (page 10-29)Reference[Removing Primary fan Duct]
- 4) Remove the developing assembly. (page 7-28)Reference[Removing Developing Assembly]

#### 7.10.1.2 Removing Process Unit

iR5065 / iR 5055 / iR5075 / iR5075N / iR5065N / iR5055N

- 1) Disconnect the 5 connectors [1] and remove the 2 screws [2].

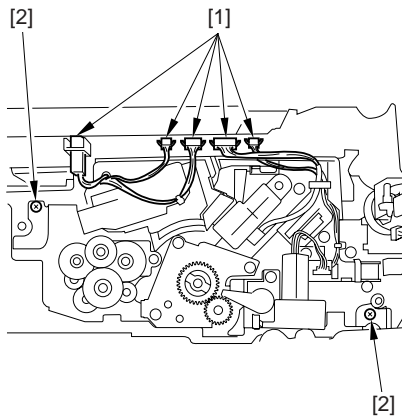

F-7-32

- 2) Insert the drum rotating tool [1] that comes with the unit into the slit [3] in the drum shaft [2]. While keeping the drum in place so that it will not rotate counterclockwise, insert a screwdriver into the center opening [4] in the drum rotating tool to remove the drum fixing screw.

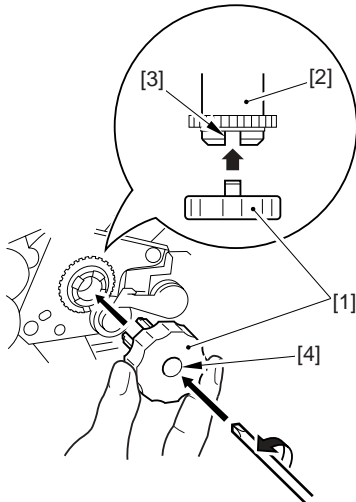

F-7-33



If the drum is let to rotate counterclockwise, the cleaning blade will not come into contact with the drum correctly, leading to poor cleaning. Thus, be sure to fix the drum in place first before removing the drum fixing screw to avoid the problem.

#### MEMO:

If the hopper assembly is released but not removed, be sure to open the right cover (upper) and the right cover (lower) so that there will be space.

- 3) Unlock the fixing feeding unit release lever [1], and slide out the fixing feeding unit [2].

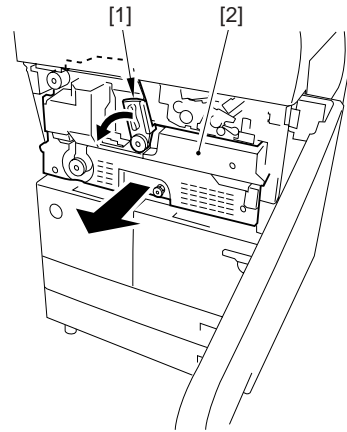

F-7-34

- 4) Slide out the process unit [1] until it stops.

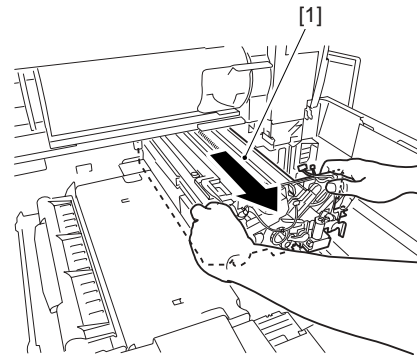

F-7-35

- 5) Hold the left grip [1] and the right grip [2] of the process unit [3] as indicated, and take it out.

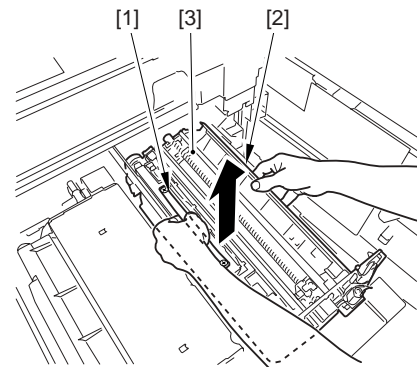

F-7-36

#### 7.10.1.3 Mounting Process Unit

iR5065 / iR 5055 / iR5075 / iR5075N / iR5065N / iR5055N

Mount the process unit by reversing the steps used to remove it with the following in mind:

- 1) On the left rail, place the process unit along the front/rear guide plates [1].  
On the right rail [2], place the process unit on the L-shaped stay.

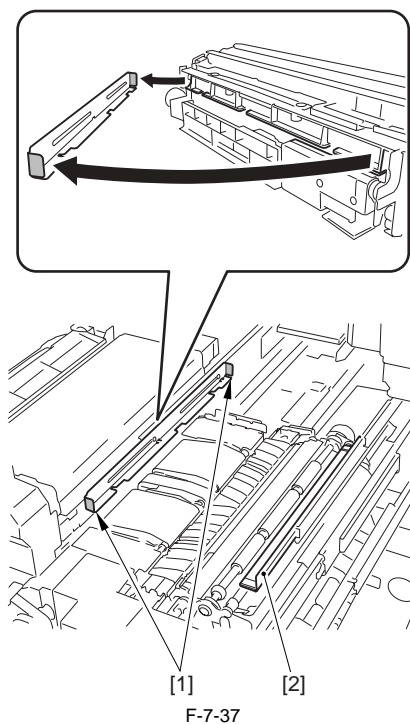

F-7-37

- 2) After sliding the process unit into the machine, insert the screw [2] by inserting the drum fixing tool [1]. Then, match the slot in the drum shaft and the drum rotating tool [3], and tighten the screw [2] using the drum rotating tool.

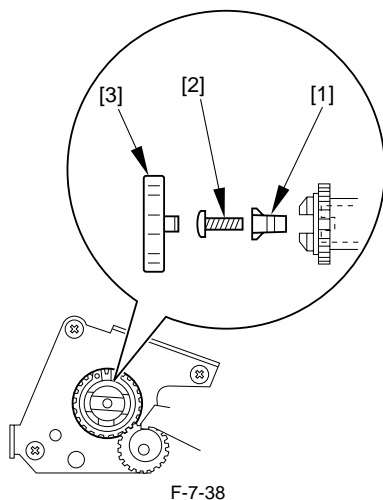

F-7-38

## 7.10.2 Pre-Exposure Lamp

### 7.10.2.1 Before Removing Pre-Exposure Lamp

iR5065 / iR 5055 / iR5075 / iR5075N / iR5065N / iR5055N

- 1) Remove the developing assembly. (page 7-28)Reference[Removing Developing Assembly]
- 2) Remove the process unit. (page 7-20)Reference[Removing Process Unit]
- 3) Remove the primary charging assembly. (page 7-21)Reference[Removing Primary Charging Assembly]
- 4) Remove the potential sensor unit. (page 7-31)Reference[Removing Potential Sensor Unit]

### 7.10.2.2 Removing Pre-Exposure Lamp

iR5065 / iR 5055 / iR5075 / iR5075N / iR5065N / iR5055N

- 1) Remove the potential sensor rail stay [2].  
- 2 screws [1]

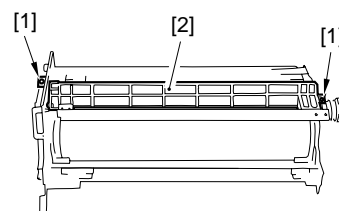

F-7-39

- 2) Remove the pre-exposure lamp unit [3].  
- 1 connector [1]  
- 2 screws [2]

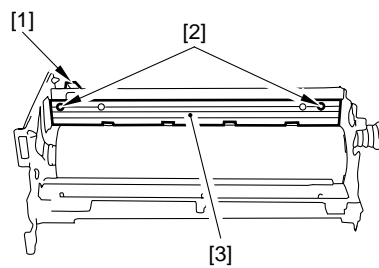

F-7-40

## 7.10.2.3 Cleaning Primary Toner Blocking Sheet

iR5065 / iR 5055 / iR5075 / iR5075N / iR5065N / iR5055N

- 1) Remove the process unit.
- 2) Remove the potential sensor rail stay [2].  
- 2 screws [1]

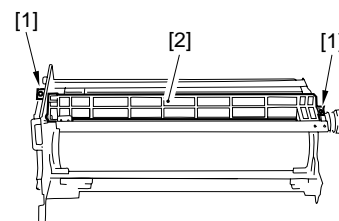

F-7-41

- 3) Clean the primary toner blocking sheet [1].

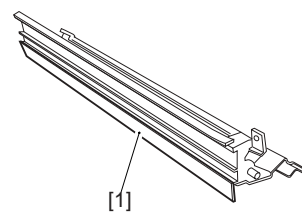

F-7-42

## 7.10.3 Primary Charging Assembly

### 7.10.3.1 Before Removing Primary Charging Assembly

iR5065 / iR 5055 / iR5075 / iR5075N / iR5065N / iR5055N

- 1) Remove the primary fan duct. (page 10-29)Reference[Removing Primary fan Duct]

### 7.10.3.2 Removing Primary Charging Assembly

iR5065 / iR 5055 / iR5075 / iR5075N / iR5065N / iR5055N

- 1) Loosen the screw [1] and shift the charging assembly fixture [2] in the direction of the arrow (upper right); then, tighten the screw again.
- 2) Remove the primary charging assembly [4].  
- 1 connector [3]

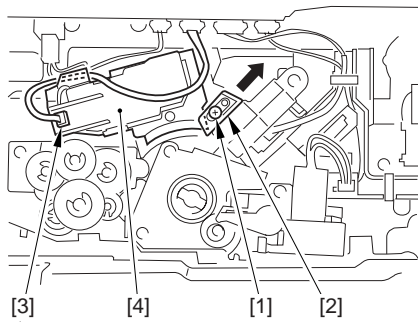

F-7-43



When replacing the primary charging wire or the primary charging assembly, be sure to execute the following in the service mode to clean the wire: COPIER > FUNCTION > CLEANING > WIRE-CLN. Further, be sure to use a strengthened polishing pad (blue holder) as the cleaning pad.

### 7.10.4 Pre-Transfer Charging Assembly

#### 7.10.4.1 Before Removing Pre-Transfer Charging Assembly

iR5065 / iR 5055 / iR5075 / iR5075N / iR5065N / iR5055N

- 1) Detach the front cover. (page 10-13)Reference[Removing the Front Cover]
- 2) Detach the toner supply cover. (page 10-14)Reference[Removing the Toner Supply Cover]
- 3) Remove the primary fan duct. (page 10-29)Reference[Removing Primary fan Duct]

#### 7.10.4.2 Removing Pre-Transfer Charging Assembly

iR5065 / iR 5055 / iR5075 / iR5075N / iR5065N / iR5055N

- 1) Shift the fixing/feeder assembly release lever to release the feeder assembly.
- 2) Remove the pre-transfer charging assembly [3].
  - 1 connector [1]
  - 1 screw [2]

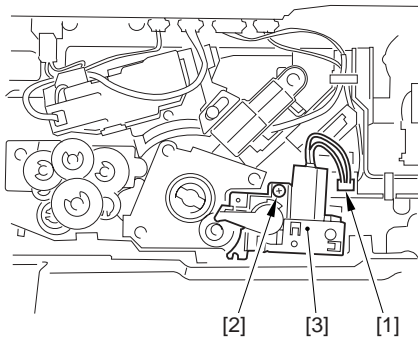

F-7-44



Be sure to execute the wire cleaning in the user mode after mounting the pre-transfer charging assembly.

### 7.10.5 Photosensitive Drum

#### 7.10.5.1 Points to Note When Handling Photosensitive Drum

iR5065 / iR 5055 / iR5075 / iR5075N / iR5065N / iR5055N

The machine's photosensitive drum is made of high-sensitivity amorphous silicon, and its sensitivity can start to deteriorate depending on how and where it is placed, requiring the following:

- [1] Whenever the process unit is removed from the machine or the photosensitive drum is removed from the process unit, be sure to protect the photosensitive drum against light. Wrap 6 or more sheets of A3 or larger paper around the photosensitive drum.
- [2] Do not place the process unit or the photosensitive drum in a area subject

to the direct rays of the sun.

- [3] Do not place the process unit or the photosensitive drum in an area subject to high or low temperature or humidity or where temperature or humidity tends to change rapidly.
  - [4] Do not place the process unit or the photosensitive drum in an area subject to dust, ammonium gas, or organic solvent/gas.
- The foregoing requirements commonly apply to all photosensitive drums.

#### 7.10.5.2 Before Removing Photosensitive Drum

iR5065 / iR 5055 / iR5075 / iR5075N / iR5065N / iR5055N

- 1) Detach the front cover. (page 10-13)Reference[Removing the Front Cover]
- 2) Detach the toner supply cover. (page 10-14)Reference[Removing the Toner Supply Cover]
- 3) Remove the primary fan duct. (page 10-29)Reference[Removing Primary fan Duct]
- 4) Remove the developing assembly. (page 7-28)Reference[Removing Developing Assembly]
- 5) Remove the process unit. (page 7-20)Reference[Removing Process Unit]
- 6) Remove the primary charging assembly. (page 7-21)Reference[Removing Primary Charging Assembly]
- 7) Remove the pre-transfer charging assembly.
- 8) Remove the potential sensor unit. (page 7-31)Reference[Removing Potential Sensor Unit]

#### 7.10.5.3 Removing Photosensitive Drum

iR5065 / iR 5055 / iR5075 / iR5075N / iR5065N / iR5055N

- 1) Remove the potential sensor rail stay [2].
  - 2 screws [1]

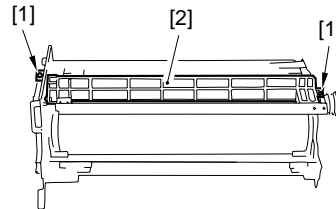

F-7-45

- 2) Remove the gear plate [2].
  - 3 screws [1]

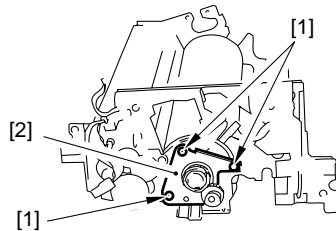

F-7-46

- 3) Remove the front side stay [2].
  - 2 screws [1]

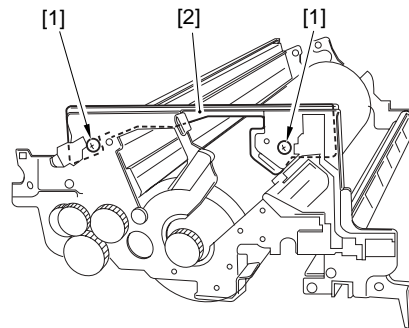

F-7-47

- 4) Remove the photosensitive drum by holding it as indicated.

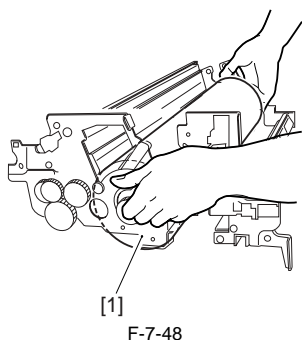

F-7-48



Be careful not to scratch the photosensitive drum when removing it. The bearing at the rear side and the gear at the front side of the photosensitive drum need not be removed.



If the temperature of the fixing assembly is 50 deg C or higher when replacing the drum unit, be sure to execute the following in the service mode; otherwise, the potential control will not be executed: COPIER > FUNCTION > DPC > DPC.

#### 7.10.5.4 Cleaning Photosensitive Drum

iR5065 / iR 5055 / iR5075 / iR5075N / iR5065N / iR5055N



Do not rotate the magnet roller during work. Otherwise, waste toner may fall through the cleaner assembly.

- 1) Remove the process unit.
- 2) Remove the photosensitive drum.
- 3) Moisten lint-free paper [1] with 5 to 10 cc of alcohol solutions [2]; then, pour 0.2 to 0.3 g of the drum cleaning powder (CK-0429) [3] on the lint-free paper.
- 4) While butting the lint-free paper relatively strongly against the photosensitive drum, wipe the surface of the drum from the front to the rear and from the rear to the front.

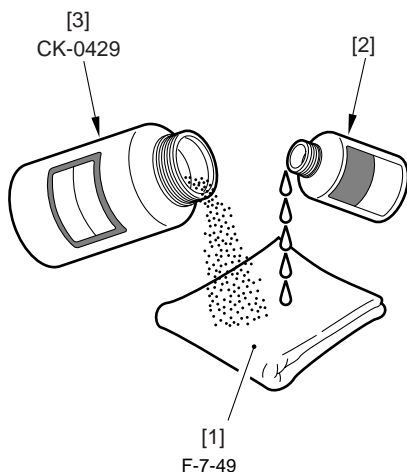

F-7-49



- Keep the widths of cleaning to 5 to 10 cm in the peripheral direction of the drum.  
- Move the lint-free paper back and forth 15 to 20 times over a single area. Forcing the lint-free paper will not affect the life of the drum.

- 5) After the alcohol has evaporated, dry wipe the surface with the lint-free paper. If the area is uneven, go back to the step 4, and increase the back-and-forth movements.
- 6) Rotate the drum for the width (5 to 10 cm), and repeat the step 3 through 5 until the entire area of the surface has been cleaned.

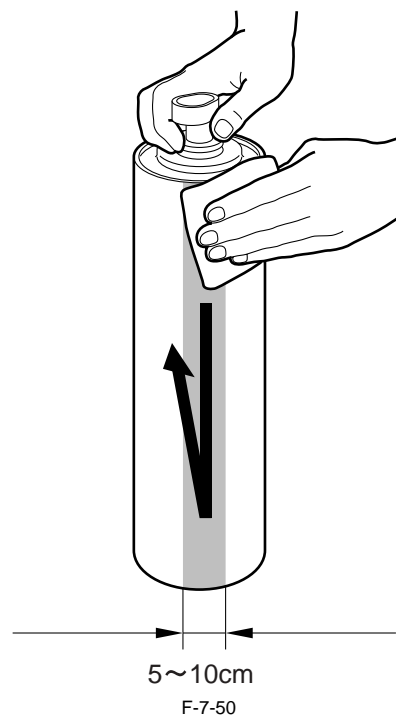

F-7-50

#### 7.10.6 Drum Motor

##### 7.10.6.1 Before Removing Drum Motor

iR5065 / iR 5055 / iR5075 / iR5075N / iR5065N / iR5055N

- 1) Remove the charger unit (this step is necessary only for iR5075 for Japan). (page 10-22) Reference[Removing the Charger unit]
- 2) Remove the rear cover (upper). (page 10-13) Reference[Removing the Rear Cover (Upper)]
- 3) Remove the rear cover (lower). (page 10-13) Reference[Removing the Rear Cover (Lower)]
- 4) Remove the main controller box cover. (page 10-17) Reference[Removing the Main Controller Box Cover]
- 5) Remove the right cover (upper rear). (page 10-12) Reference[Removing the Right Cover (Upper Rear)]
- 6) Remove the main controller box. (page 4-13) Reference[Removing the Main Controller Box]
- 7) Remove the right cover (lower rear). (page 10-12) Reference[Removing the Right Cover (Lower Rear)]
- 8) Remove the collecting toner bottle holder. (page 5-29) Reference[Removing the Collecting Toner Bottle Holder]

##### 7.10.6.2 Removing Drum Motor

iR5065 / iR 5055 / iR5075 / iR5075N / iR5065N / iR5055N

- 1) Remove the flywheel [2].  
- 2 screws [1]

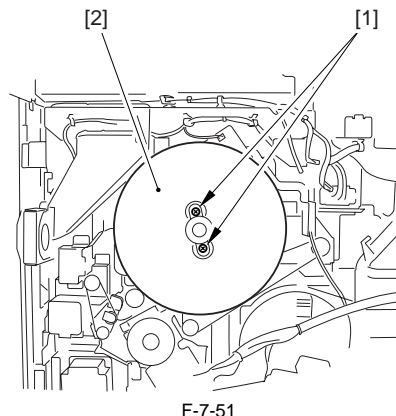

F-7-51

- 2) Remove the drum motor [3].  
- 2 connectors [1]  
- 4 screws [2]

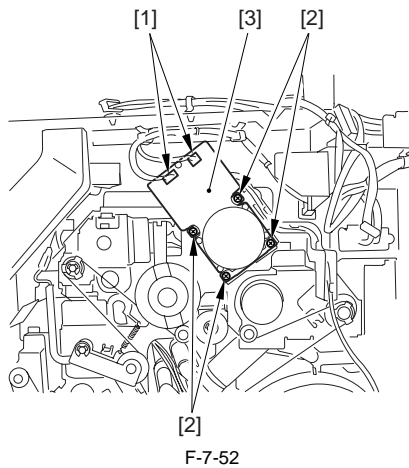

F-7-52

## 7.10.7 Photosensitive Drum Heater

### 7.10.7.1 Points to Note When Handling Photosensitive Drum

iR5065 / iR 5055 / iR5075 / iR5075N / iR5065N / iR5055N

The machine's photosensitive drum is made of high-sensitivity amorphous silicon, and its sensitivity can start to deteriorate depending on how and where it is placed, requiring the following:

- [1] Whenever the process unit is removed from the machine or the photosensitive drum is removed from the process unit, be sure to protect the photosensitive drum against light. Wrap 6 or more sheets of A3 or larger paper around the photosensitive drum.
  - [2] Do not place the process unit or the photosensitive drum in an area subject to the direct rays of the sun.
  - [3] Do not place the process unit or the photosensitive drum in an area subject to high or low temperature or humidity or where temperature or humidity tends to change rapidly.
  - [4] Do not place the process unit or the photosensitive drum in an area subject to dust, ammonium gas, or organic solvent/gas.
- The foregoing requirements commonly apply to all photosensitive drums.

### 7.10.7.2 Before Removing Photosensitive Drum Heater

iR5065 / iR 5055 / iR5075 / iR5075N / iR5065N / iR5055N

- 1) Detach the front cover. (page 10-13)Reference[Removing the Front Cover]
- 2) Detach the toner supply cover. (page 10-14)Reference[Removing the Toner Supply Cover]
- 3) Remove the primary fan duct. (page 10-29)Reference[Removing Primary fan Duct]
- 4) Remove the developing assembly. (page 7-28)Reference[Removing Developing Assembly]
- 5) Remove the process unit. (page 7-20)Reference[Removing Process Unit]
- 6) Remove the primary charging assembly. (page 7-21)Reference[Removing Primary Charging Assembly]
- 7) Remove the pre-transfer charging assembly.
- 8) Remove the potential sensor unit. (page 7-31)Reference[Removing Potential Sensor Unit]
- 9) Remove the photosensitive drum. (page 7-22)Reference[Removing Photosensitive Drum]

### 7.10.7.3 Removing Drum Heater

iR5065 / iR 5055 / iR5075 / iR5075N / iR5065N / iR5055N

- 1) Remove the flange [2] from the front.  
- 2 screws [1]

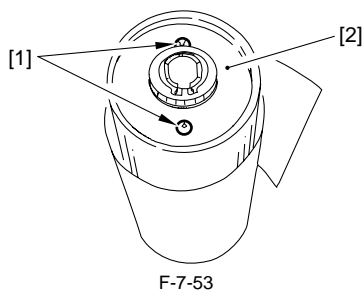

F-7-53



Protect the removed photosensitive drum against dirt and scratches by wrapping 5 to 6 sheets of paper or the drum protective sheet stored near the collecting toner container around the drum.

- 2) Remove the drum heater unit [1] from the rear.

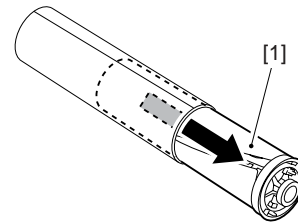

F-7-54

- 3) Remove the drum heater [2].  
- 1 connector [1]

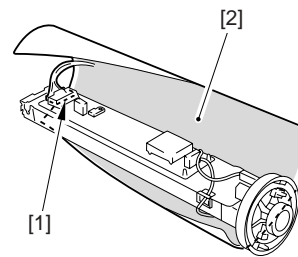

F-7-55

### 7.10.7.4 Points to Note When Mounting Drum Heater

iR5065 / iR 5055 / iR5075 / iR5075N / iR5065N / iR5055N

Mount the photosensitive drum heater by reversing the steps used to remove it. However, be sure not to soil or scratches the drum and not to trap the cable of the drum heater.

## 7.10.8 Cleaning Blade

### 7.10.8.1 Configuration

iR5065 / iR 5055 / iR5075 / iR5075N / iR5065N / iR5055N

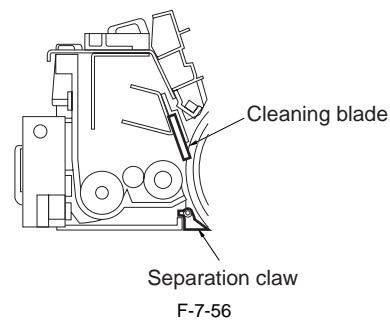

F-7-56

### 7.10.8.2 Before Removing Cleaning Blade

iR5065 / iR 5055 / iR5075 / iR5075N / iR5065N / iR5055N

- 1) Detach the front cover. (page 10-13)Reference[Removing the Front Cover]
- 2) Detach the toner supply cover. (page 10-14)Reference[Removing the Toner Supply Cover]
- 3) Remove the primary fan duct. (page 10-29)Reference[Removing Primary fan Duct]
- 4) Remove the developing assembly. (page 7-28)Reference[Removing Developing Assembly]
- 5) Remove the process unit. (page 7-20)Reference[Removing Process Unit]
- 6) Remove the primary charging assembly. (page 7-21)Reference[Removing Primary Charging Assembly]

### 7.10.8.3 Removing Cleaning Blade

iR5065 / iR 5055 / iR5075 / iR5075N / iR5065N / iR5055N

- 1) Remove the 4 screws [1].



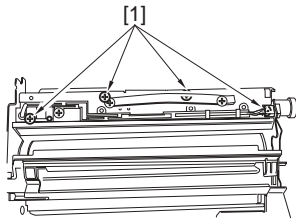

F-7-57

- 2) Detach the cover [2].  
- 1 screw [1]
- [3] Free the harness from the edge saddle, and disconnect the connector [3].

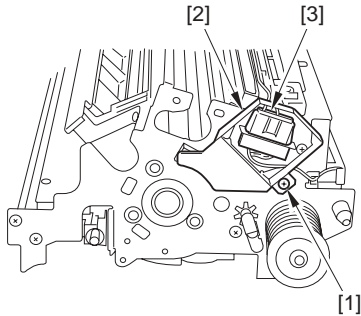

F-7-58

- 4) Move the harness guide [1] in the direction of the arrow.  
- 1 screw [2]
- 5) Put back the harness guide to its original position, and remove the cleaning blade assembly [3].

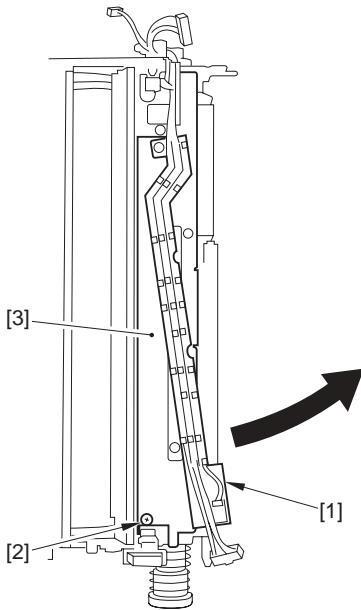

F-7-59

- 6) Remove the pressure spring [2].  
- 1 E-ring [1] (lower side of the cleaning blade assembly)

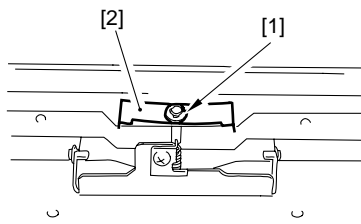

F-7-60

- 7) Remove the pre-exposure LED assembly [3].  
- 1 connector [1]  
- 2 screws [2]

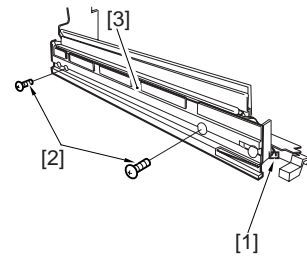

F-7-61

- 8) Loosen the 5 screws [1], and remove the cleaning blade from the blade support plate.

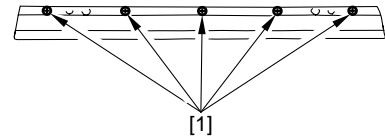

F-7-62

### 7.10.8.4 Mounting Cleaning Blade

iR5065 / iR 5055 / iR5075 / iR5075N / iR5065N / iR5055N

When mounting the cleaning blade, be sure that the side with the marking [1] will be the face.

- 1) Push in the cleaning blade [2] until it butts slightly against the rear.

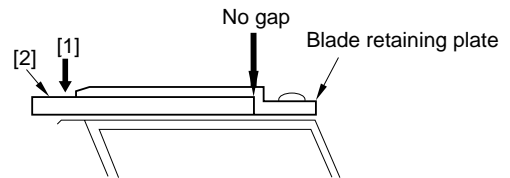

F-7-63

- 2) Tighten the 5 screws [3] lightly, and stop to turn them when resistance is felt.
- 3) Turn the screws tightened lightly in the step 2 about 20 to 30 degrees in the order indicated below, and tighten them fully.

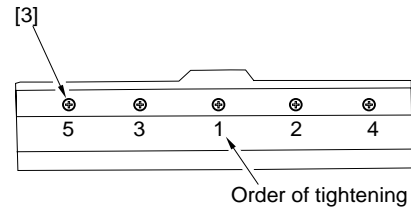

F-7-64



After mounting the cleaning blade, check that the edge of the blade is not extremely bent. Further, be sure to clean the groove in the blade support plate before mounting the blade, as toner or the like in the groove can be the cause the bending of the blade. AB

### 7.10.9 Side Seal

#### 7.10.9.1 Before Removing Side Seal

iR5065 / iR 5055 / iR5075 / iR5075N / iR5065N / iR5055N

- 1) Detach the front cover. (page 10-13)Reference[Removing the Front Cover]
- 2) Detach the toner supply cover. (page 10-14)Reference[Removing the Toner Supply Cover]
- 3) Remove the primary fan duct. (page 10-29)Reference[Removing Primary fan Duct]
- 4) Remove the developing assembly. (page 7-28)Reference[Removing Developing Assembly]
- 5) Remove the process unit. (page 7-20)Reference[Removing Process Unit]
- 6) Remove the primary charging assembly. (page 7-21)Reference[Removing Primary Charging Assembly]
- 7) Remove the pre-transfer charging assembly.
- 8) Remove the potential sensor unit. (page 7-31)Reference[Removing Potential Sensor Unit]

- 9) Remove the photosensitive drum. (page 7-22)Reference[Removing Photosensitive Drum]

### 7.10.9.2 Removing Side Seal

iR5065 / iR 5055 / iR5075 / iR5075N / iR5065N / iR5055N

- 1) Remove the old side seal.
- 2) Mount the new side seal [1] to the cleaner housing where indicated (both ends).  
At this time, be sure that the edge of the side seal is positioned as follow:  
- When replacing the side seal [1] at the front, push the magnet roller [2] toward the rear, and then, make sure that the inner end of the side seal is within the area [3] of the washer.  
- When replacing the side seal [1] at the rear, push the magnet roller [2] toward the front, and then, make sure that the inner end of the side seal is within the area [3] of the washer.
- 3) The bottom end of each side seal [1] must be 0 to 0.5 mm from the corner of the cleaner housing; i.e., point of reference [4].
- 4) Attach the side seal [1] at the front and the rear to the cleaner housing while making sure its position is as indicated.

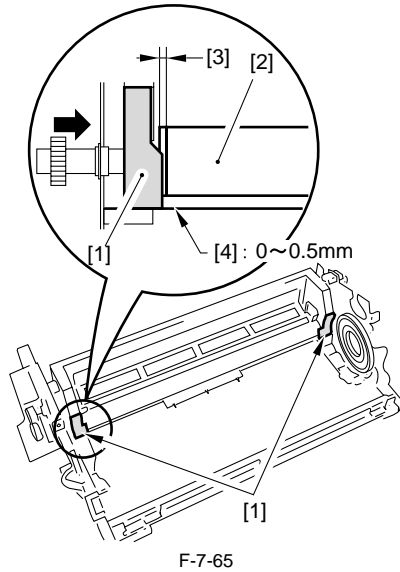

F-7-65

### 7.10.10 Cleaner Scraper

#### 7.10.10.1 Before Cleaning Cleaner Scraper

iR5065 / iR 5055 / iR5075 / iR5075N / iR5065N / iR5055N

- 1) Detach the front cover. (page 10-13)Reference[Removing the Front Cover]
- 2) Detach the toner supply cover. (page 10-14)Reference[Removing the Toner Supply Cover]
- 3) Remove the primary fan duct. (page 10-29)Reference[Removing Primary fan Duct]
- 4) Remove the developing assembly. (page 7-28)Reference[Removing Developing Assembly]
- 5) Remove the process unit. (page 7-20)Reference[Removing Process Unit]
- 6) Remove the primary charging assembly. (page 7-21)Reference[Removing Primary Charging Assembly]

#### 7.10.10.2 Cleaning Cleaner Scraper

iR5065 / iR 5055 / iR5075 / iR5075N / iR5065N / iR5055N

- 1) Remove the cleaning blade.
- 2) Remove any paper lint accumulated at the tip of the cleaner scraper (A; the area between the magnet roller and the toner guide roller) with tweezers.
- 3) Remove the toner from the surface of the magnet roller. (Roll a paper into a U-shape to scoop it up.)

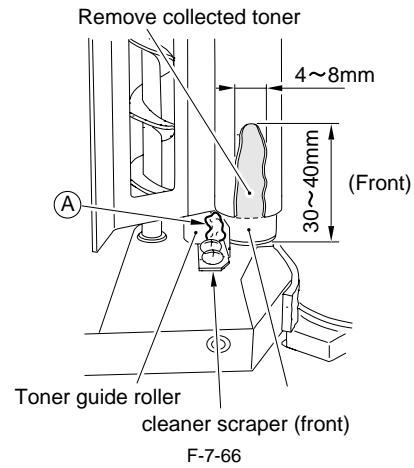

F-7-66

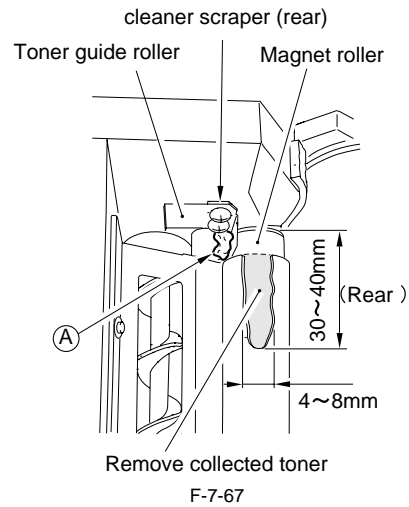

F-7-67

- 4) Rotate the magnet roller in the clockwise direction (viewing from the front).
- 5) Repeat the step 3 through 4 until the area from which toner was removed in the step 3 is once again coated with an even layer of toner.

### 7.10.11 Hopper Assembly

#### 7.10.11.1 Before Removing Hopper Assembly

iR5065 / iR 5055 / iR5075 / iR5075N / iR5065N / iR5055N

- 1) Detach the front cover. (page 10-13)Reference[Removing the Front Cover]
- 2) Detach the toner supply cover. (page 10-14)Reference[Removing the Toner Supply Cover]
- 3) Remove the primary fan duct. (page 10-29)Reference[Removing Primary fan Duct]

#### 7.10.11.2 Removing Hopper Assembly

iR5065 / iR 5055 / iR5075 / iR5075N / iR5065N / iR5055N

- 1) Open the right door unit (upper) [1], and remove the screw [2] from the door tape; then, open the unit fully.

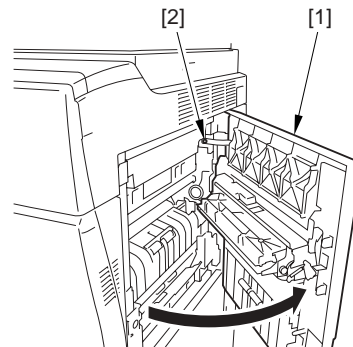

F-7-68

- 2) Remove the developing locking assembly [2] by pushing it in the direction

of the arrow.  
- 1 screw [1]

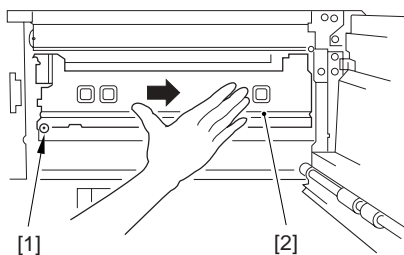

F-7-69

- 3) Remove the toner bottle.
- 4) Remove the hopper assembly [3].



If tilting the hopper assembly, toner will be spilled out; thus, be sure to remove it without tilting.

- 1 connector [1]
- 5 screws [2]

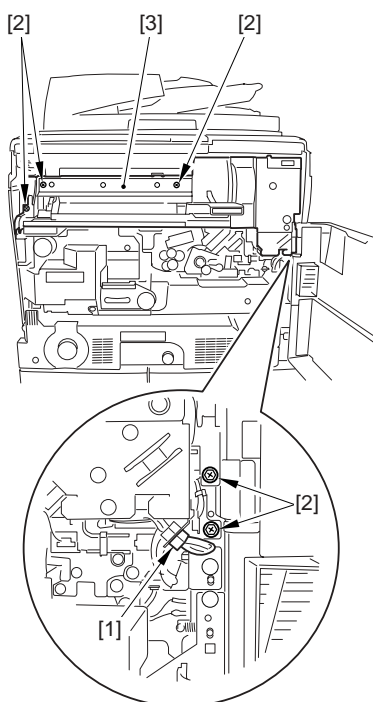

F-7-70

## 7.10.12 Hopper Supply Motor

### 7.10.12.1 Before Removing Toner Supply Motor

iR5065 / iR 5055 / iR5075 / iR5075N / iR5065N / iR5055N

- 1) Detach the front cover. ([page 10-13](#))Reference[Removing the Front Cover]
- 2) Detach the toner supply cover. ([page 10-14](#))Reference[Removing the Toner Supply Cover]
- 3) Remove the primary fan duct. ([page 10-29](#))Reference[Removing Primary fan Duct]
- 4) Detach the right cover (upper). ([page 10-12](#))Reference[Removing the Right Cover (Upper)]

### 7.10.12.2 Removing Toner Supply Motor

iR5065 / iR 5055 / iR5075 / iR5075N / iR5065N / iR5055N

- 1) Open the manual feeding tray cover.
- 2) Remove the 3 screws [1].
- 3) Slide the lever [2] slightly upward, and detach the hopper front cover [3].

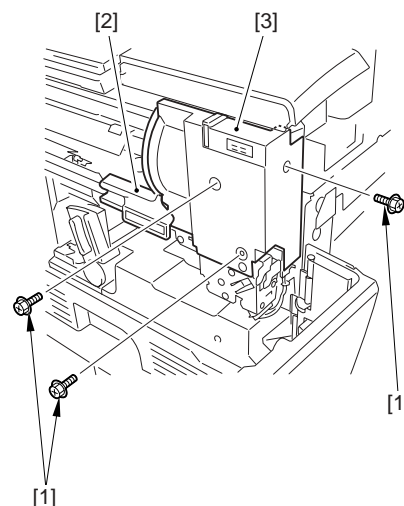

F-7-71

- 4) Remove the toner supply motor [3].
  - 1 connector [1]
  - 3 screws [2]

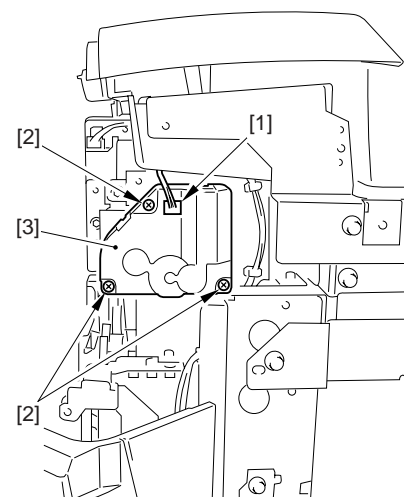

F-7-72

## 7.10.13 Hopper String Motor

### 7.10.13.1 Before Removing Hopper Stirring Motor

iR5065 / iR 5055 / iR5075 / iR5075N / iR5065N / iR5055N

- 1) Detach the front cover. ([page 10-13](#))Reference[Removing the Front Cover]
- 2) Detach the toner supply cover. ([page 10-14](#))Reference[Removing the Toner Supply Cover]
- 3) Remove the primary fan duct. ([page 10-29](#))Reference[Removing Primary fan Duct]
- 4) Detach the right cover (upper). ([page 10-12](#))Reference[Removing the Right Cover (Upper)]

### 7.10.13.2 Removing Hopper Stirring Motor

iR5065 / iR 5055 / iR5075 / iR5075N / iR5065N / iR5055N

- 1) Free the harness from the cord guide [2].
  - 1 connector [1]
- 2) Remove the hopper drive unit [4] by sliding it in the direction of the arrow.
  - 4 screws [3]

### 7.10.14 Developing Assembly

#### 7.10.14.1 Removing Developing Assembly

iR5065 / iR 5055 / iR5075 / iR5075N / iR5065N / iR5055N



The machine's developing assembly is not equipped with a cover to protect the developing cylinder.

If you must remove the developing assembly, be sure not to damage the developing cylinder.

When the developing assembly is outside the machine, be sure not to mount the developing assembly locking assembly. The toner collecting in the path from the hopper to the developing assembly may be strayed because of the vibration occurring during the inspection or repair work.

- 1) Open the right door unit (upper) [1], and remove the screw [2] from the door tape; then, open the unit fully.

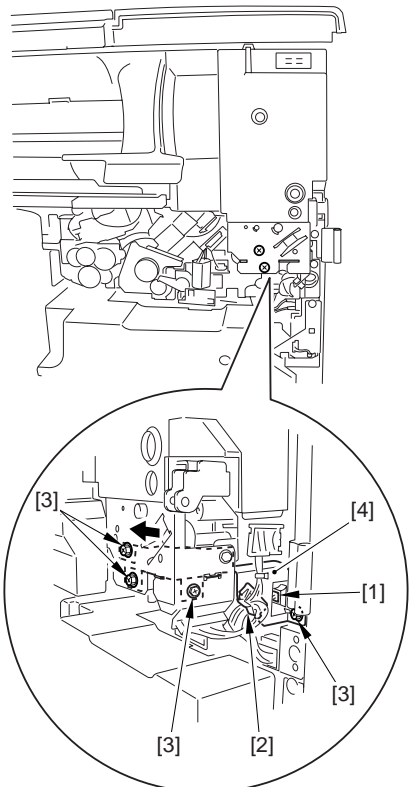

F-7-73

- 3) Free the harness from the wire saddle [2].  
- 1 connector [1]

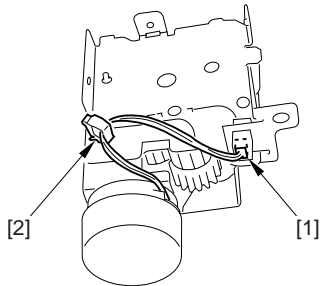

F-7-74

- 4) Remove the hopper stirring motor [2] together with the mount.  
- 2 screws [1]

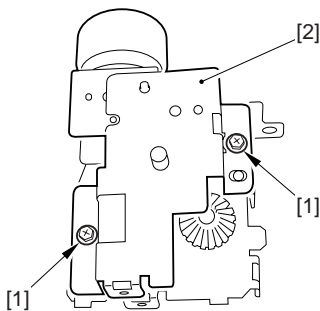

F-7-75

- 5) Remove the hopper stirring motor [2].  
- 1 screw [1]

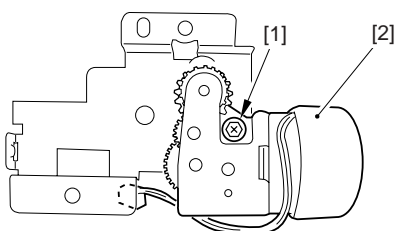

F-7-76

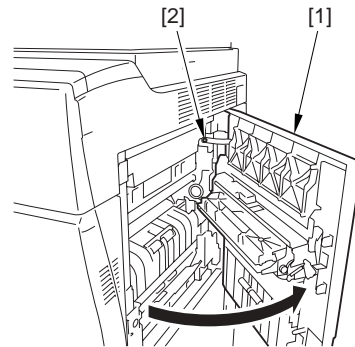

F-7-77

- 2) Remove the developing locking assembly [2] by pushing it in the direction of the arrow.  
- 1 screw [1]

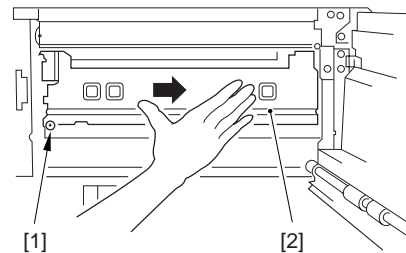

F-7-78

- 3) Remove the developing assembly [2] from the machine slowly.  
- 1 connector [1]

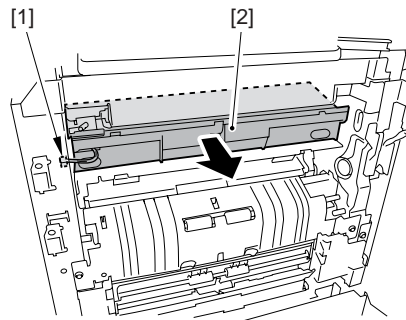

F-7-79

#### 7.10.14.2 Cleaning Developing Toner Blocking Sheet

iR5065 / iR 5055 / iR5075 / iR5075N / iR5065N / iR5055N

- 1) Remove the developing assembly, and clean the developing toner blocking sheet [1].

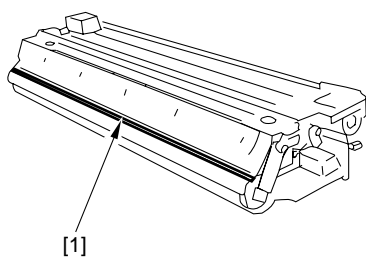

F-7-80

### 7.10.15 Developing Cylinder

#### 7.10.15.1 Before Removing Developing Cylinder

iR5065 / iR 5055 / iR5075 / iR5075N / iR5065N / iR5055N

- 1) Remove the developing assembly. (page 7-28)Reference[Removing Developing Assembly]
- 2) Remove the developing blade. (page 7-29)Reference[Removing Developing Blade]

#### 7.10.15.2 Removing Developing Cylinder

iR5065 / iR 5055 / iR5075 / iR5075N / iR5065N / iR5055N

- 1) Remove the gear unit [2] together with the gear.  
- 2 screws [1]

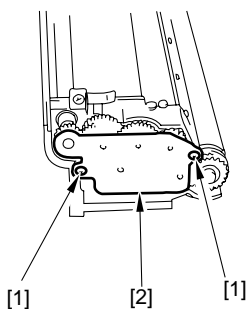

F-7-81



Be careful not to drop the gear when removing the gear unit because it becomes free

- 2) Remove the grip ring [1] attached to the cylinder shaft at the rear; then, remove the gear [2], the parallel pin [3], and the push-on roll [4].

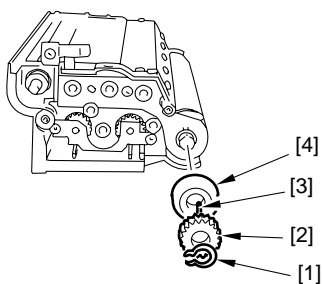

F-7-82

- 3) Remove the electrode plate [2].  
- 2 screws [1]

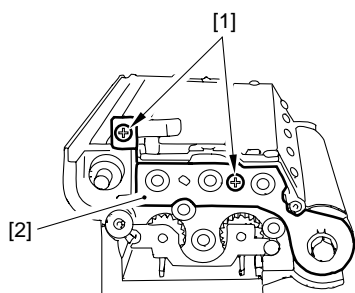

F-7-83

- 4) Remove the grip ring [1] attached to the cylinder shaft at the front; then,

remove the push-on roll [2].

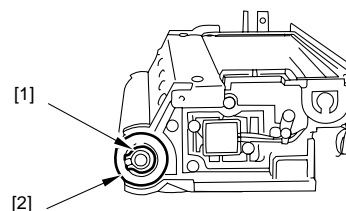

F-7-84

- 5) Remove the developing cylinder [2].  
- 2 bearings [1] (at the front and the rear)

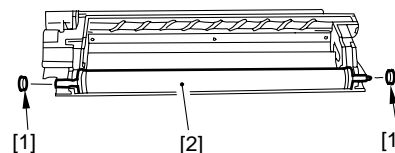

F-7-85



Do not leave fingerprints or oils on the surface of the developing cylinder. Otherwise, dry wipe it with lint-free paper. (Do not use solvent.)

### 7.10.16 Developing Blade

#### 7.10.16.1 Before Removing Developing Blade

iR5065 / iR 5055 / iR5075 / iR5075N / iR5065N / iR5055N

- 1) Remove the developing assembly. (page 7-28)Reference[Removing Developing Assembly]

#### 7.10.16.2 Removing Developing Blade

iR5065 / iR 5055 / iR5075 / iR5075N / iR5065N / iR5055N

- 1) Detach the developing assembly cover [2].  
- 2 mounting screws [1]

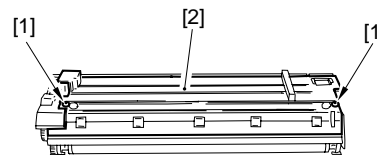

F-7-86

- 2) Place a newspaper on the floor or a desk, and pour out the toner onto the newspaper from the developing blade assembly.
- 3) Remove the developing blade [2] together with the mount.  
- 2 mounting screws [1]

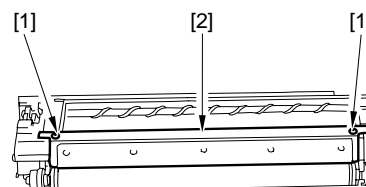

F-7-87



The blade must be mounted with a high accuracy. Do not remove it on its own in the field. Be sure to remove it together with the mount.

#### 7.10.16.3 Mounting Developing Blade

iR5065 / iR 5055 / iR5075 / iR5075N / iR5065N / iR5055N

Mount the blade by reversing the steps used to remove it.

- 1) Push the blade mount against the developing assembly, and tighten the 2 mounting screws.  
When mounting the blade, place a paper on the developing cylinder first to protect the cylinder.

## 7.10.17 Transfer/Separation Charging Assembly

### 7.10.17.1 Removing Transfer/Separation Charging Assembly

iR5065 / iR 5055 / iR5075 / iR5075N / iR5065N / iR5055N

- 1) Open the front cover, and slide out the fixing/feeding assembly.
- 2) Detach the fixing/feeding unit front cover (right) [2].  
- 2 screws [1]

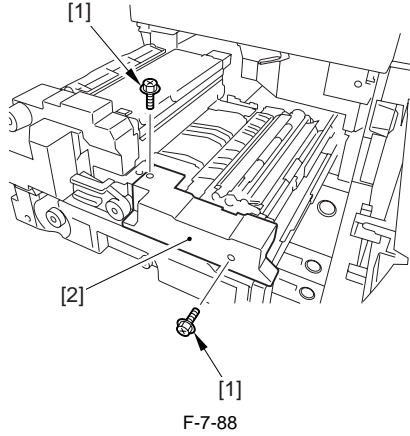

- 3) Disconnect the connector [3].  
- 1 screw [1]  
- 1 fixture [2]

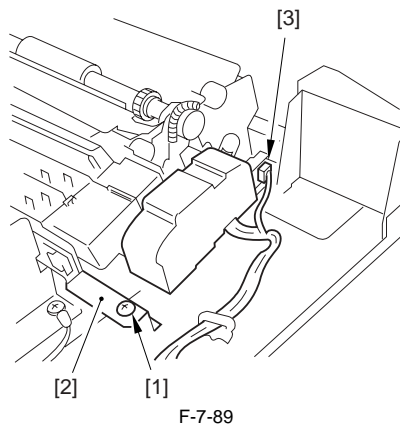

- 4) Pull out the transfer/separation charging assembly toward the front while holding the front and the rear of it, and remove it in the direction of upper left.

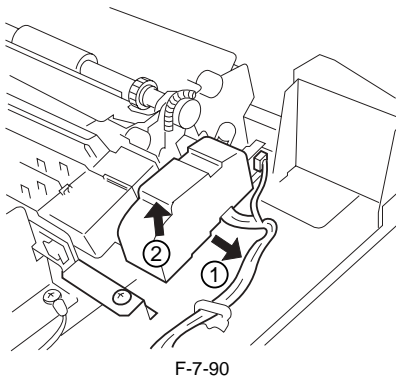

Be careful not to cut the nylon wire by coming into contact the transfer/separation charging assembly to the transfer guide.

### 7.10.17.2 Mounting Transfer/Separation Charging Assembly

iR5065 / iR 5055 / iR5075 / iR5075N / iR5065N / iR5055N

Mount the transfer/separation charging assembly by reversing the steps used to remove it while keeping the followings in mind.

- 1) Make sure that the 4 protrusions [1] on the transfer/separation charging assembly are correctly fitted into the cut-offs [2] in the fixing/feeding unit.
- 2) Make sure that the leaf spring [3] of the fixing/feeding unit comes in contact with the frame of the transfer/separation charging assembly by sliding the assembly from the front.

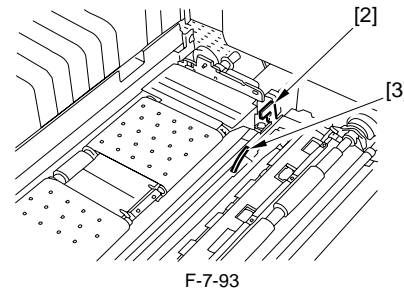
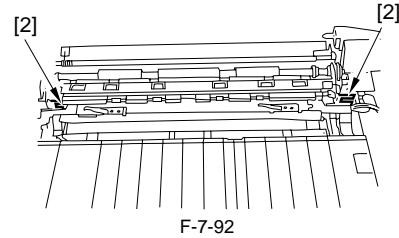
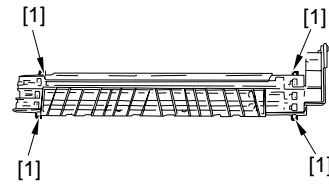

- 3) Attach the fixing guide plate [1] with the screw [2].

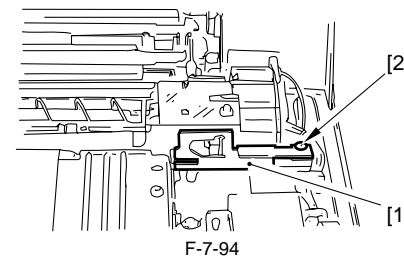

- 4) When replacing the transfer charging wire or the transfer/separation charging assembly, be sure to execute the following in the service mode to clean the wire: COPIER > FUNCTION > CLEANING > WIRE-CLN. When replacing the separation charging wire, be sure to execute the wire cleaning in the user mode.



Further, be sure to use a strengthened polishing pad (blue holder) as the cleaning pad for the transfer charging wire.

## 7.10.18 Separation Claw/Separation Claw Drive Assembly

### 7.10.18.1 Before Removing Separation Claw Holder

iR5065 / iR 5055 / iR5075 / iR5075N / iR5065N / iR5055N

- 1) Detach the front cover. (page 10-13)Reference[Removing the Front Cover]
- 2) Detach the toner supply cover. (page 10-14)Reference[Removing the Toner Supply Cover]
- 3) Remove the primary fan duct. (page 10-29)Reference[Removing Primary fan Duct]
- 4) Remove the developing assembly. (page 7-28)Reference[Removing Developing Assembly]
- 5) Remove the process unit. (page 7-20)Reference[Removing Process Unit]

### 7.10.18.2 Removing Separation Claw Holder

iR5065 / iR 5055 / iR5075 / iR5075N / iR5065N / iR5055N

- 1) Slide the cover [2].

- 1 screw [1]
- 2) Detach the cover while pulling the separation claw holder [4] toward the front.
- 2 screws [3]

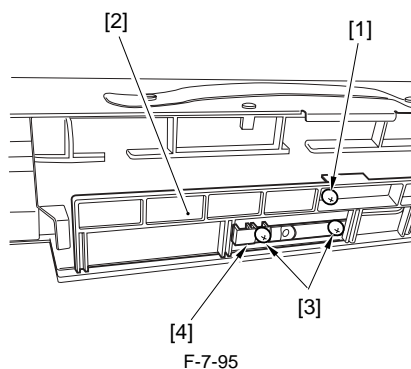

F-7-95



Be careful not to break the separation claw.

## 7.10.19 Potential Sensor Unit

### 7.10.19.1 Outline

iR5065 / iR 5055 / iR5075 / iR5075N / iR5065N / iR5055N

The potential sensor unit includes the following 4 parts:

- Potential control PCB
- Potential sensor
- Potential sensor relay harness (between the relay connector and the potential control PCB)
- Potential sensor harness (between the potential sensor and the relay connector)

Be sure to replace them at the same time.

### 7.10.19.2 Before Removing Potential Sensor Unit

iR5065 / iR 5055 / iR5075 / iR5075N / iR5065N / iR5055N

- 1) Detach the front cover. (page 10-13)Reference[Removing the Front Cover]
- 2) Detach the toner supply cover. (page 10-14)Reference[Removing the Toner Supply Cover]
- 3) Remove the primary fan duct. (page 10-29)Reference[Removing Primary fan Duct]

### 7.10.19.3 Removing Potential Sensor Unit

iR5065 / iR 5055 / iR5075 / iR5075N / iR5065N / iR5055N

- 1) Remove the potential sensor unit [3].
  - 1 connector [1]
  - 1 screw [2]
  - Cable (free from the cable guide)

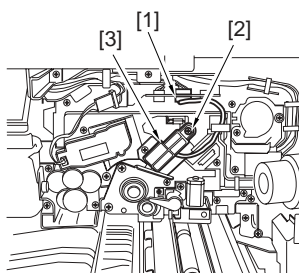

F-7-96

## 7.10.20 Charging Wire

### 7.10.20.1 Outline

iR5065 / iR 5055 / iR5075 / iR5075N / iR5065N / iR5055N

The photosensitive drum is surrounded by 3 charging wires; the primary charging wire, the pre-transfer charging wire, and the transfer/separation charging wire.

These charging wires are newly adopted brown wires (0.06 mm in diameter). Do not use a gold-plated wire that has been used in the past; otherwise, image fault may occur.

Further, be sure to use a strengthened polishing pad (in a blue holder) as the cleaning pad for the primary charging assembly and the transfer charging as-

sembly.

### 7.10.20.2 Routing Charging Wire

iR5065 / iR 5055 / iR5075 / iR5075N / iR5065N / iR5055N

All charging wires (except the grid wire) are routed more or less in the same way; the following cites the primary charging assembly.

- 1) Remove the shield plates (left, right) of the charging assembly. To prevent deformation (deflection) in the primary charging assembly, be sure to work separately for the left shielding plate and the right shielding plate (do not loosen the screws [1] of both shielding plates at the same time.)
- 2) Remove the wire cleaner.

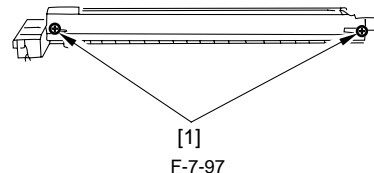

F-7-97



For other charging assemblies, remove the 2 covers.

- 3) Free a length of about 5 cm of the charging wire (0.06 mm in diameter) from the charging wire reel, and form a loop at its end with a diameter of about 2 mm.

#### MEMO:

To form a loop, wind the charging wire around a hex key once, and turn the hex key 3 to 4 times; then, twist the charging wire.

- 4) Cut the end (excess) of the twisted wire.
- 5) Hook the loop on the stud.

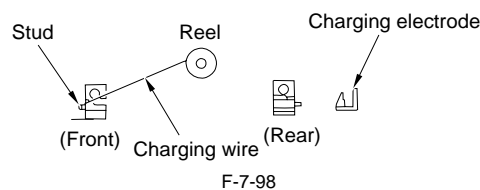

F-7-98

- 6) At the rear, hook the charging wire on the charging wire positioning plate; then, hook the charging wire tension spring on the charging wire where indicated to the following figure.



F-7-99

- 7) Cut off the excess of the charging wire with nippers.
- 8) Pick the end of the charging wire tension spring with tweezers, and hook it on the charging power supply electrode. In the case of the pre-transfer charging assembly, hook the spring on the pin at the front.

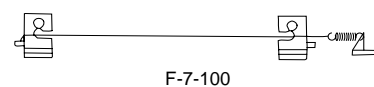

F-7-100

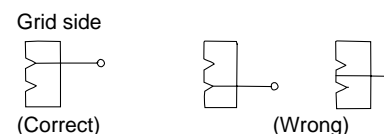
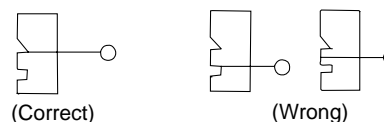

F-7-101



Make sure the followings:

- The charging wire must not be bent or twisted.
- The charging wire must be fitted in the V-groove of the charging wire positioning plate.

- 9) Attach a cushion in front of the charging wire (except the primary charging assembly).
- 10) Attach the shield plates (left, right).



For other charging assemblies, attach the 2 covers.

- 11) Attach the wire cleaner. At this time, make sure the orientation of the wire cleaner.
- 12) Wipe the charging wire with lint-free paper moistened with alcohol solutions.

### 7.10.20.3 Routing Grid for Primary Charging Assembly

iR5065 / iR 5055 / iR5075 / iR5075N / iR5065N / iR5055N

- 1) Loosen the 2 screws used to secure the left and right shielding plates in place.
- 2) Loosen the 3 screws used to secure the motor unit at the front in place.

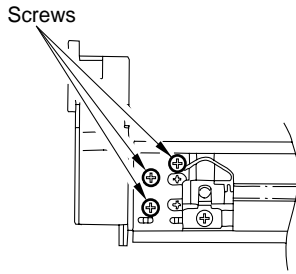

F-7-102

- 3) Loosen the screw, and move it in the direction of the arrow indicated below; then, temporarily tighten it in place.
- 4) Free a length of about 5 cm of the charging wire (0.1 mm in diameter) from the charging wire reel, and form a loop at its end with a diameter of about 2 mm.

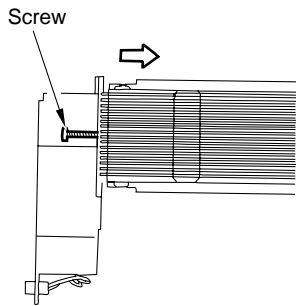

F-7-103

**MEMO:**

To form a loop, wind the charging wire around a hex key once, and turn the hex key 3 to 4 times; then, twist the charging wire.

- 5) Cut the twisted charging wire (excess) with nippers.
- 6) Hook the loop on the stud A.
- 7) After routing the wire for 31 runs, lead it through the section B, and give it a half turn; then, put it between the washer and the monitor unit, and wind it once around the screw (clockwise), and secure it in place with the screw.

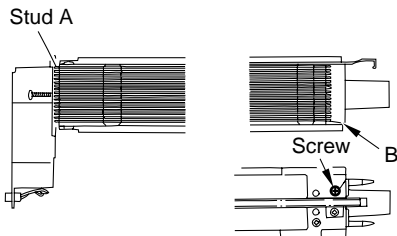

F-7-104

- 8) Cut the excess of the charging wire with nippers.
- 9) Tighten the screw loosened in the step 3.  
Keep tightening until the tension of the grid wire is even. Be sure to pay attention to avoid deformation (deflection) of the charging assembly (as by tightening the screw at the front of the left/right shielding plate early).
- 10) Tighten the screws loosened in the step 1 and 2.
- 11) Wipe the grid wire with lint-free paper moistened with alcohol solutions.



Make sure the followings:

- The grid wire must not be bent or twisted.
- The wires are laid at equal intervals. (The grid wire must be fitted in the groove of the block.)

### 7.10.20.4 Adjusting Height of Charging Wire

iR5065 / iR 5055 / iR5075 / iR5075N / iR5065N / iR5055N

[1] Primary charging wire

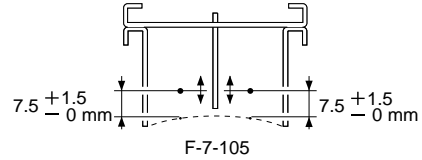

Height of the charging wire  
<Tolerance> +/-1 mm

[2] Pre-transfer charging wire

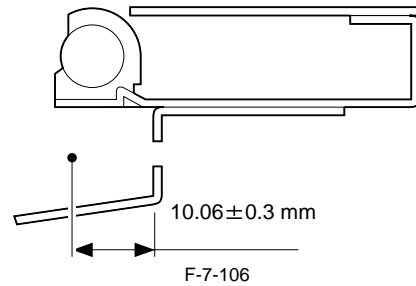

Height of the charging wire  
<Tolerance> No height adjusting mechanism

[3] Transfer charging wire

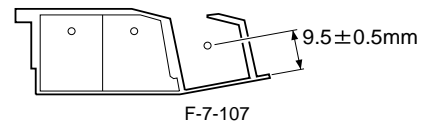

Height of the charging wire  
<Tolerance> +/-2 mm

[4] Separation charging wire

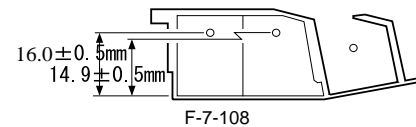

Height of the charging wire  
<Tolerance> +/-2 mm

**MEMO:**

The height (position) of the primary charging wire and the transfer charging wire can be adjusted by turning the screw at the back of the charging assembly. A single turn changes the position of the charging wire by about 0.7 mm.



---

## Chapter 8 Pickup/Feeding System

---



---

# Contents

8.1 Construction .....	8-1
8.1.1 Specifications and construction .....	8-1
8.1.2 Arrangement of Rollers and Sensors .....	8-1
8.1.3 Outline of the Pickup Control System .....	8-3
8.1.4 Outline of the Pickup Assembly Motor Control System .....	8-5
8.2 Basic Sequence .....	8-6
8.2.1 Pickup from the Right Deck .....	8-6
8.2.2 Pickup from the Cassette 3 .....	8-7
8.2.3 Pickup Retry Operation.....	8-8
8.3 Detecting Jams .....	8-8
8.3.1 Jam Detection Outline.....	8-8
8.3.1.1 Outline.....	8-8
8.3.1.2 Jam History .....	8-10
8.3.2 Delay Jams .....	8-10
8.3.2.1 Cassette Pickup Assembly (right deck, left deck, cassette 3/4).....	8-10
8.3.2.2 Other Delay Jam.....	8-10
8.3.3 Stationary Jams .....	8-11
8.3.3.1 Common Delay Jams .....	8-11
8.3.3.2 Power-On Stationary Jam .....	8-12
8.4 Cassette Pick-Up Unit.....	8-12
8.4.1 Lifter Operation (cassette 3/4) .....	8-12
8.4.2 Detecting the Presence/Absence of Paper.....	8-13
8.4.3 Outline of the Paper Level Detection Mechanism .....	8-14
8.4.4 Paper Level Detection (cassette 3/4).....	8-14
8.4.5 Identifying the Size of Paper (cassette 3/4) .....	8-14
8.4.6 Markings on the Width Guide Rail.....	8-15
8.4.7 Paper Size.....	8-15
8.5 Manual Feed Pickup Unit .....	8-17
8.5.1 Pickup Operation .....	8-17
8.5.2 Detecting the Size of Paper in the Manual Feed Tray .....	8-18
8.6 Deck .....	8-19
8.6.1 Lifter Operation (right/left deck) .....	8-19
8.6.2 Lifter Limiter (right/left deck) Control Circuit.....	8-19
8.6.3 Detecting the Presence/Absence of Paper.....	8-20
8.6.4 Outline of Paper Level Detection .....	8-20
8.6.5 Paper Level Detection Operation (right/left deck).....	8-21
8.6.6 Identifying the Size of Paper (right/left deck) .....	8-21
8.7 Registration Unit.....	8-21
8.7.1 Outline.....	8-21
8.7.2 Control System.....	8-22
8.8 Duplex Feeding Unit.....	8-22
8.8.1 Moving the Paper to the Reversing Assembly After Printing on the 1st Side.....	8-22
8.8.2 Moving the Paper to the Duplexing Feed Assembly From the Reversing Assembly .....	8-22
8.8.3 Outline.....	8-23
8.8.4 Sequence of Printing Operation .....	8-23
8.8.5 Outline of Through-Path Operation .....	8-24
8.8.6 Through-Path Operation .....	8-24
8.8.7 Outline of Horizontal Registration Position .....	8-28
8.8.8 Horizontal Registration Position Detection Operation .....	8-28
8.9 Delivery.....	8-29

8.9.1 Reversal Delivery Operation.....	8-29
8.10 Cassette Heater .....	8-30
8.10.1 Timing of the Cassette Heater Supplied with Power .....	8-30
8.11 Parts Replacement Procedure .....	8-31
8.11.1 Pickup Roller .....	8-31
8.11.1.1 Before Removing the Pickup Roller .....	8-31
8.11.1.2 Removing the Pickup Roller .....	8-31
8.11.1.3 Points to Note When Mounting the Pickup Roller .....	8-31
8.11.2 Cassette Pickup Assembly .....	8-31
8.11.2.1 Removing the Cassette 3/4 Pickup Assembly .....	8-31
8.11.3 Cassette Pickup Motor .....	8-31
8.11.3.1 Before Removing the Cassette 3/4 Pickup Motor .....	8-31
8.11.3.2 Removing the Cassette 3/4 Pickup Motor .....	8-31
8.11.4 Cassette Lifter Motor .....	8-32
8.11.4.1 Removing the Cassette 3 Lifter Motor M20 .....	8-32
8.11.4.2 Removing the Cassette 4 Lifter Motor M21 .....	8-32
8.11.4.3 Adjusting the Position of the Lifter Motor M20/M21 of the Cassette 3/4 .....	8-33
8.11.5 Left Deck Lifter Motor .....	8-33
8.11.5.1 Before Removing the Left Deck Lifter Motor .....	8-33
8.11.5.2 Removing the Left Deck Lifter Motor .....	8-33
8.11.6 Right Deck Lifter Motor .....	8-34
8.11.6.1 Before Removing the Right Deck Lifter Motor .....	8-34
8.11.6.2 Removing the Right Deck Lifter Motor .....	8-34
8.11.7 Right Deck Pickup Assembly .....	8-35
8.11.7.1 Removing the Right Deck Pickup Assembly .....	8-35
8.11.8 Left Deck Pickup Assembly .....	8-35
8.11.8.1 Removing the Left Deck Pickup Assembly .....	8-35
8.11.9 Left Deck Pickup Motor .....	8-36
8.11.9.1 Before Removing the Left Deck Pickup Motor .....	8-36
8.11.9.2 Removing the Left Deck Pickup Motor .....	8-36
8.11.10 Right Deck Pickup Motor .....	8-36
8.11.10.1 Before Removing the Right Deck Pickup Motor .....	8-36
8.11.10.2 Removing the Right Deck Pickup Motor .....	8-36
8.11.11 Left Deck Pickup Sensor .....	8-36
8.11.11.1 Before Removing the Left Deck Feeding Sensor .....	8-36
8.11.11.2 Removing the Left Deck Feeding Sensor .....	8-36
8.11.12 Left Deck Pickup Solenoid .....	8-36
8.11.12.1 Before Removing the Left Deck Pickup Solenoid .....	8-36
8.11.12.2 Removing the Left Deck Pickup Solenoid .....	8-37
8.11.12.3 Adjusting the Position of the Left Deck Pickup Solenoid .....	8-37
8.11.13 Manual Feed Pull-Out Roller Unit .....	8-37
8.11.13.1 Removing the Manual Feeding Pickup Roller Unit .....	8-37
8.11.14 Manual Feed Pull-Out Roller .....	8-37
8.11.14.1 Before Removing the Manual Feeding Pickup Roller .....	8-37
8.11.14.2 Removing the Manual Feeding Pickup Roller .....	8-37
8.11.15 Manual Feed Roller .....	8-38
8.11.15.1 Before Removing the Manual Feeding Roller .....	8-38
8.11.15.2 Removing the Manual Feeding Roller .....	8-38
8.11.16 Manual Separation Roller .....	8-38
8.11.16.1 Before Removing the Manual Separation Roller .....	8-38
8.11.16.2 Removing the Manual Separation Roller .....	8-38
8.11.16.3 Adjusting the Pressure of the Manual Separation Roller .....	8-38
8.11.17 Manual Feed Tray paper sensor .....	8-39
8.11.17.1 Removing the Manual Feeding Tray Sensor .....	8-39
8.11.18 Registration Roller .....	8-39
8.11.18.1 Before Removing the Registration Roller .....	8-39
8.11.18.2 Removing the Registration Roller .....	8-39
8.11.19 Pre-Registration Roller .....	8-40
8.11.19.1 Before Removing the Registration Lower Roller .....	8-40

8.11.19.2 Removing the Registration Lower Roller .....	8-40
8.11.20 Pre-Registration Motor .....	8-41
8.11.20.1 Before Removing the Registration Front Motor .....	8-41
8.11.20.2 Removing the Registration Front Motor .....	8-41
8.11.21 Registration Motor .....	8-41
8.11.21.1 Before Removing the Horizontal Registration Motor .....	8-41
8.11.21.2 Removing the Horizontal Registration Motor .....	8-41
8.11.22 Registration Sensor .....	8-42
8.11.22.1 Before Removing the Horizontal Registration Sensor .....	8-42
8.11.22.2 Removing the Horizontal Registration Sensor .....	8-42
8.11.23 Registration Clutch .....	8-43
8.11.23.1 Before Removing the Registration Clutch .....	8-43
8.11.23.2 Removing the Registration Clutch .....	8-43
8.11.24 Registration Brake Clutch .....	8-43
8.11.24.1 Before Removing the Registration Brake .....	8-43
8.11.24.2 Removing the Registration Brake .....	8-43
8.11.25 Feeding Roller .....	8-43
8.11.25.1 Before Removing the Feeding Roller .....	8-43
8.11.25.2 Removing the Feeding Roller .....	8-43
8.11.25.3 The Points to Mount the Feeding Roller .....	8-44
8.11.26 Vertical Path Roller .....	8-44
8.11.26.1 Before Removing the Vertical Path Roller .....	8-44
8.11.26.2 Removing the Vertical Path Roller .....	8-44
8.11.26.3 Removing the Vertical Path Roller 2/3 .....	8-44
8.11.27 Vertical Path Motor .....	8-44
8.11.27.1 Before Removing the Vertical Path Upper Motor .....	8-44
8.11.27.2 Removing the Vertical Path Upper Motor .....	8-45
8.11.28 Vertical Path Duplex Motor .....	8-45
8.11.28.1 Before Removing the Vertical Path Duplex Motor .....	8-45
8.11.28.2 Removing the Vertical Path Duplex Motor .....	8-45
8.11.29 Vertical Path Lower Motor .....	8-45
8.11.29.1 Before Removing the Vertical Path Lower Motor .....	8-45
8.11.29.2 Removing the Vertical Path Lower Motor .....	8-45
8.11.30 Reversing Motor .....	8-45
8.11.30.1 Before Removing the Reversing Motor .....	8-45
8.11.30.2 Removing the Reversing Motor .....	8-46
8.11.30.3 Mounting the Reversing Motor .....	8-46
8.11.31 Fixing Feeding Unit Releasing Lever Sensor .....	8-46
8.11.31.1 Before Removing the Fixing Feeding Unit Release Lever Sensor .....	8-46
8.11.31.2 Removing the Fixing Feeding Unit Release Lever Sensor .....	8-46
8.11.32 Reversing Sensor .....	8-46
8.11.32.1 Before Removing the Reversing Sensor 1 .....	8-46
8.11.32.2 Removing the Reversing Sensor 1 .....	8-46
8.11.32.3 Before Removing the Reversing Sensor 2 .....	8-47
8.11.32.4 Removing the Reversing Sensor 2 .....	8-47
8.11.33 Reversing Unit .....	8-47
8.11.33.1 Before Removing the Reversing Flapper Solenoid .....	8-47
8.11.33.2 Removing the Reversing Flapper Solenoid .....	8-47
8.11.33.3 Mounting the Reversing Flapper Solenoid .....	8-47
8.11.34 Feeding Belt .....	8-48
8.11.34.1 Before Removing the feeding belt .....	8-48
8.11.34.2 Removing the feeding belt .....	8-48
8.11.35 Duplexing Unit .....	8-49
8.11.35.1 Before Removing the Duplex Feeding Unit .....	8-49
8.11.35.2 Removing the Duplex Feeding Unit .....	8-49
8.11.36 Duplex Feed Motor .....	8-49
8.11.36.1 Before Removing the Duplex Feeding Left Motor .....	8-49
8.11.36.2 Removing the Duplex Feeding Left Motor .....	8-49
8.11.36.3 Before Removing the Duplex Feeding Right Motor .....	8-49
8.11.36.4 Removing the Duplex Feeding Right Motor .....	8-49

8.11.37 Duplex Feed Sensor .....	8-49
8.11.37.1 Before Removing the Duplex Pre-Registration Sensor .....	8-49
8.11.37.2 Removing the Duplex Pre-Registration Sensor .....	8-49
8.11.38 Separation Roller .....	8-50
8.11.38.1 Before Removing the Separation Roller .....	8-50
8.11.38.2 Removing the Separation Roller .....	8-50
8.11.38.3 Points to Note When Mounting the Separation Roller .....	8-50
8.11.38.4 Adjusting the Pressure of the Deck/Cassette Separation Roller .....	8-51

## 8.1 Construction

### 8.1.1 Specifications and construction

iR5065 / iR 5055 / iR5075 / iR5075N / iR5065N / iR5055N

The following shows the functions and the construction of the machine's pickup/feed system:

T-8-1

Item	Description	
Paper movement reference	center	
Paper capacity	paper deck (right, left)	1,500 sheets each (80 g/m <sup>2</sup> )
	front cassette (3, 4)	550 sheets each (80 g/m <sup>2</sup> )
	manual feed tray	50 sheets (80 g/m <sup>2</sup> )
Paper size switchover	paper deck (right, left)	by service person
	front cassette 3, 4	by user
	manual feed tray	by user
Duplexing method	through path	
Related user mode	auto cassette selection on/off	
	paper type registration	
Related mechanical adjustment	deck side registration adjustment	
	cassette horizontal registration adjustment	
	manual feed tray horizontal registration adjustment	

### 8.1.2 Arrangement of Rollers and Sensors

iR5065 / iR 5055 / iR5075 / iR5075N / iR5065N / iR5055N

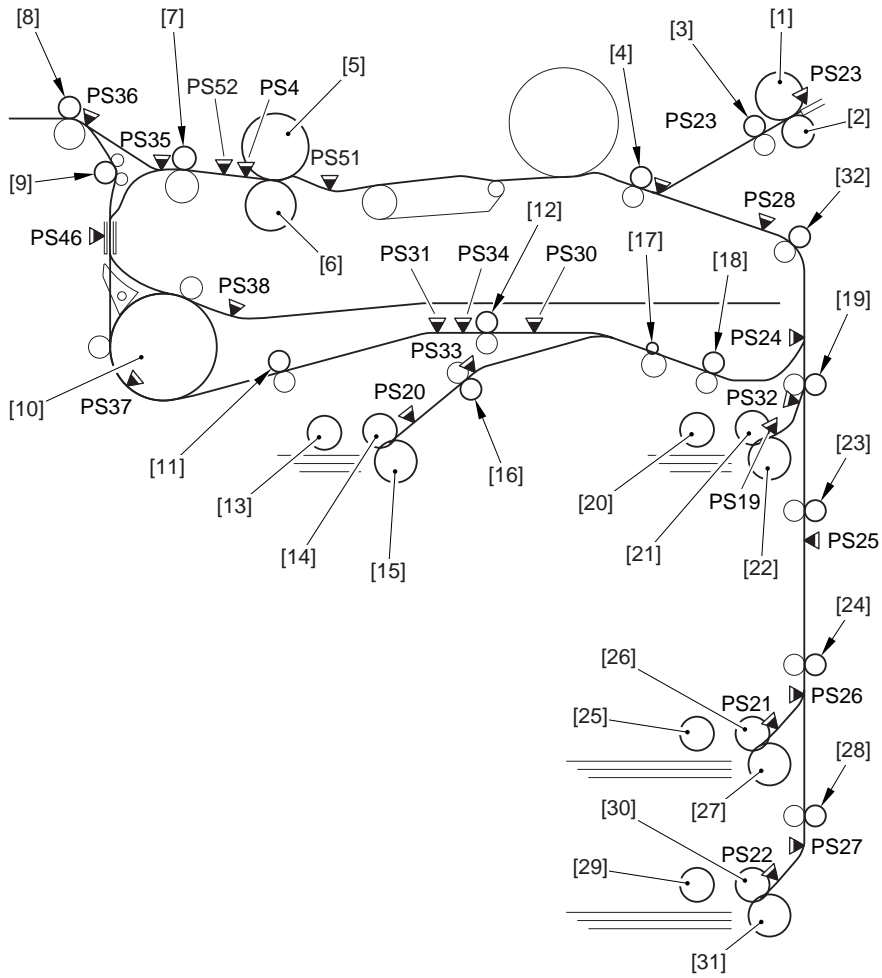

F-8-1

The machine uses the following sensors to monitor the movement of paper:

T-8-2

Notation	Name	Notation	Name
PS4	fixing claw jam sensor	PS30	duplex pre-registration sensor
PS19	right deck retry sensor	PS31	duplex horizontal registration sensor
PS20	left deck retry sensor	PS32	right deck pull-off sensor
PS21	cassette 3 retry sensor	PS33	left deck pull-off sensor
PS22	cassette 4 retry sensor	PS34	duplex paper sensor
PS23	manual feed paper sensor	PS35	inside delivery sensor
PS24	vertical path 1 sensor	PS36	outside delivery sensor
PS25	vertical path 2 sensor	PS37	reversal sensor 1
PS26	vertical path 3 sensor	PS38	reversal sensor 2
PS27	vertical path 4 sensor	PS46	delivery assembly jam sensor
PS28	write check sensor	PS51	fixing inlet sensor
PS29	registration sensor	PS52	fixing outlet sensor

The following shows the major rollers of the machine:

T-8-3

Ref.	Name	Ref.	Name
[1]	manual feed roller	[17]	curl-imparting roller
[2]	manual feed separation roller	[18]	duplexing outlet roller
[3]	manual feed pull-off roller	[19]	pickup vertical path 1 roller
[4]	registration roller	[20]	right deck pickup roller
[5]	fixing upper roller	[21]	right deck feed roller



Ref.	Name	Ref.	Name
[6]	fixing lower roller	[22]	right deck separation roller
[7]	inside delivery roller	[23]	pickup vertical path 2 roller
[8]	outside delivery roller	[24]	pickup vertical path 3 roller
[9]	delivery auxiliary roller	[25]	cassette 3 pickup roller
[10]	reversing roller	[26]	cassette 3 feed roller
[11]	duplexing feed left roller	[27]	cassette 3 separation roller
[12]	duplexing feed right roller	[28]	pickup vertical path 4 roller
[13]	left deck pickup roller	[29]	cassette 4 pickup roller
[14]	left deck feed droller	[30]	cassette 4 feed roller
[15]	left deck separation roller	[31]	cassette 4 separation roller
[16]	left deck pull-off roller		

### 8.1.3 Outline of the Pickup Control System

iR5065 / iR 5055 / iR5075 / iR5075N / iR5065N / iR5055N

The paper inside the deck/cassette is held up by the work of the lifter, and its surface remains in contact with the pickup roller, which is driven by the pickup motor (M11, M12, M24).

When the pickup motor (M11, M12, M24) goes on, the pickup roller starts to rotate to feed paper into the machine.

When the pickup solenoid (SL3, SL4, SL6, SL7) goes on, the pickup roller leaves the surface of the paper.

The feed roller and the separation roller make sure that only a single sheet of paper is moved to the paper path; the sheet is then moved through the vertical path to reach the registration roller.

The machine's pickup motor (M11, M12, M24) is equipped with a mechanism to facilitate the separation of paper. The use of a stepping motor enables the machine to slow down pickup speed.

The following is a diagram of the pickup control system used for the deck:

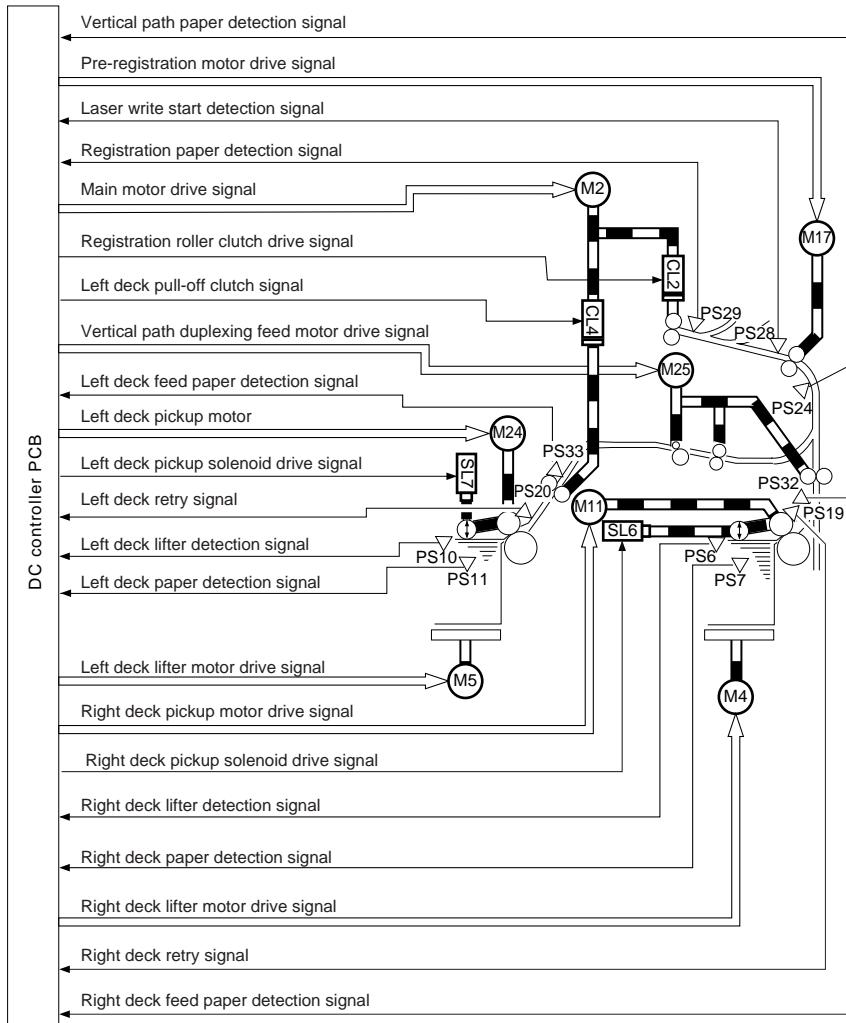

F-8-2

The following is a diagram of the machine's cassette pickup control system:

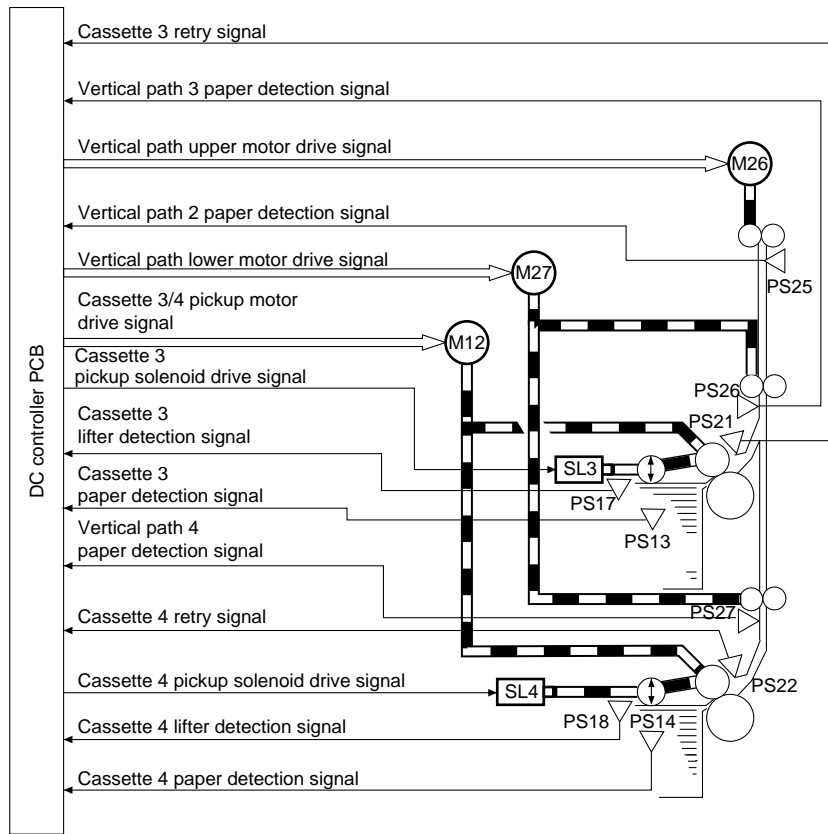

F-8-3

**8.1.4 Outline of the Pickup Assembly Motor Control System**

iR5065 / iR 5055 / iR5075 / iR5075N / iR5065N / iR5055N

The machine uses 12 stepping motors of a 2-phase excitation type. Each of these motors is supplied with 24-V power by the motor drive PCB, and is turned on and off by the pulse signals from the DC controller PCB; its direction of rotation is also controlled by the DC controller PCB. The following shows the motors used in the machine's pickup assembly, and the diagram that follows shows the control circuit used for the cassette 3/4 pickup motor (representative of all pickup motor control circuits):

T-8-4

Location	Motor	Remarks
Pickup system	right door pickup motor (M11)	error in motor leads to paper jam
	left deck pickup motor (M24)	same as above
	cassette 3/4 pickup motor (M12)	same as above
Vertical path system	vertical path upper motor (M26)	same as above
	vertical path lower motor (M27)	same as above
	vertical path duplex feed motor (M25)	same as above

Location	Motor	Remarks
Reversal/ duplexing system	reversal motor (M14)	same as above
	duplexing feed left motor (M19)	same as above
	duplexing feed right motor (M18)	same as above
	duplexing horizontal registration motor (M16)	error code "E051"
	pre-registration motor (M17)	error in motor leads to paper jam
others	delivery motor (M13)	same as above

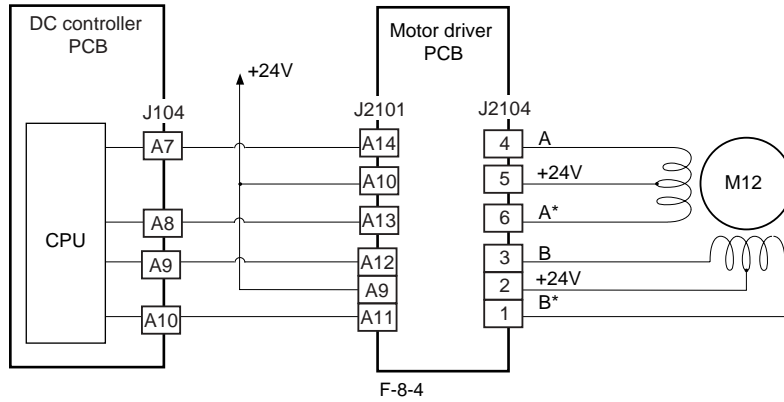

## 8.2 Basic Sequence

### 8.2.1 Pickup from the Right Deck

iR5065 / iR 5055 / iR5075 / iR5075N / iR5065N / iR5055N

- A4, 2 Prints, Continuous

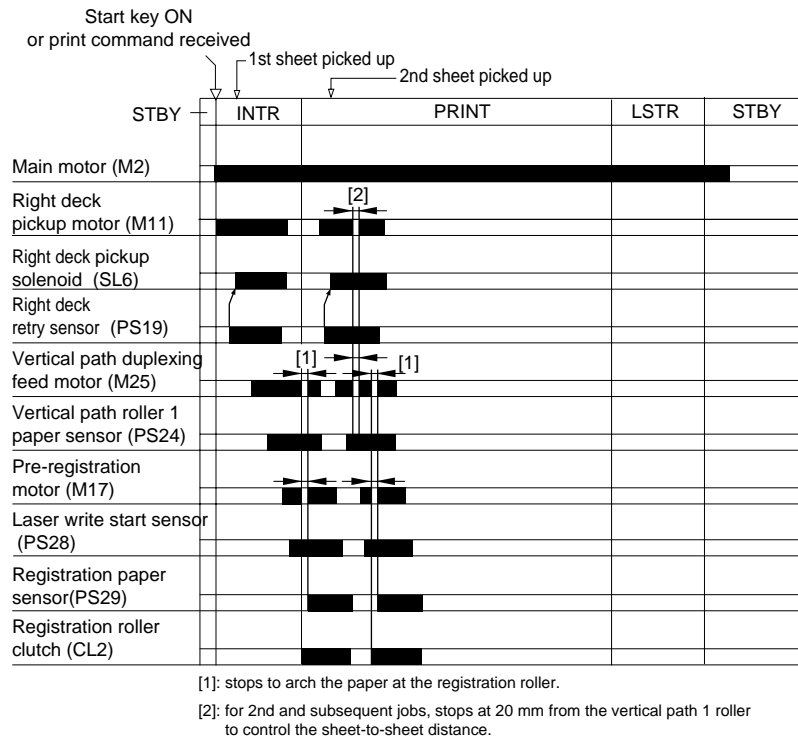

F-8-5

### 8.2.2 Pickup from the Cassette 3

iR5065 / iR 5055 / iR5075 / iR5075N / iR5065N / iR5055N

- A4, 2 Prints, Continuous

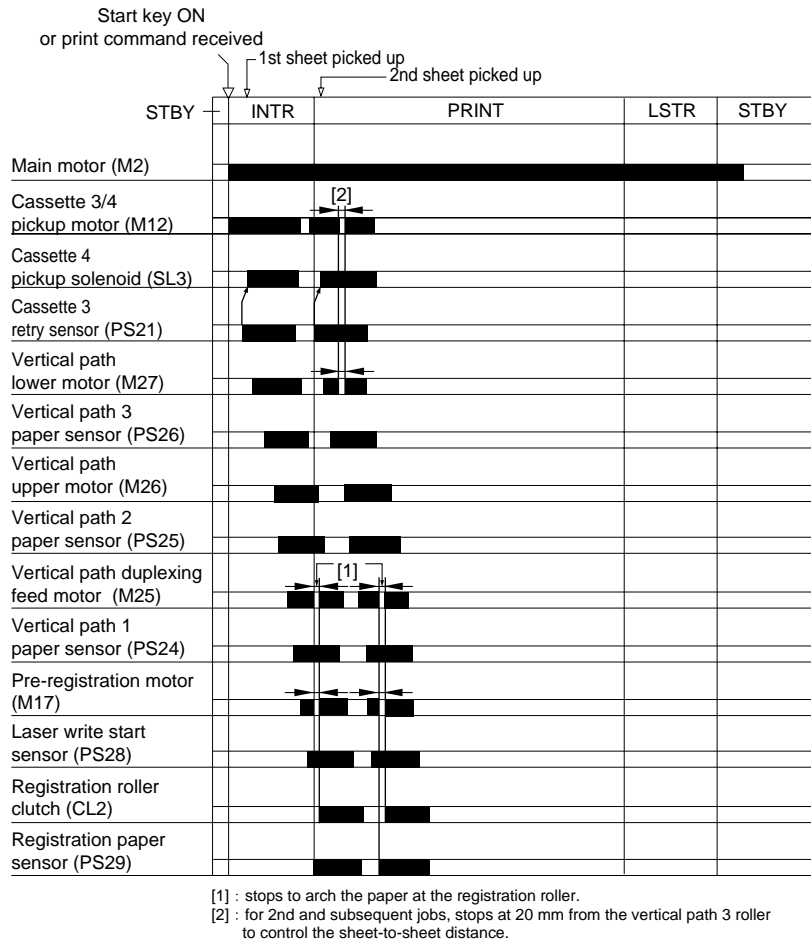

F-8-6

### 8.2.3 Pickup Retry Operation

iR5065 / iR 5055 / iR5075 / iR5075N / iR5065N / iR5055N

If, because of wear on the pickup roller for example, the retry sensor (PS19, PS20, PS21, PS22) detects a delay, the machine executes a pickup retry operation. If a delay is once again detected after the retry operation, the machine will indicate the presence of a jam on the control panel. The machine executes a retry operation as follows and at the following timing:

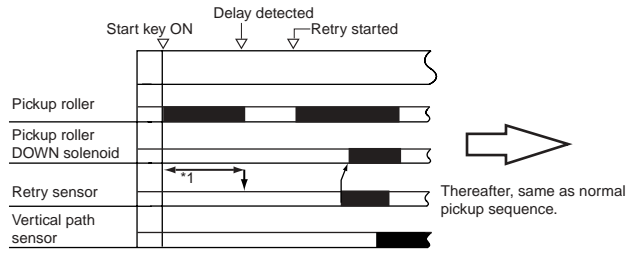
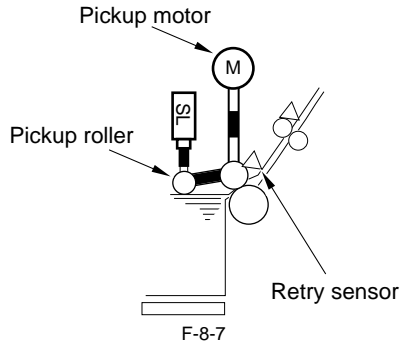

\*1 : Period of detection, determined by the clock pulses from the motor.

F-8-8

## 8.3 Detecting Jams

### 8.3.1 Jam Detection Outline

#### 8.3.1.1 Outline

iR5065 / iR 5055 / iR5075 / iR5075N / iR5065N / iR5055N

#### Arrangement of the Jam Sensors

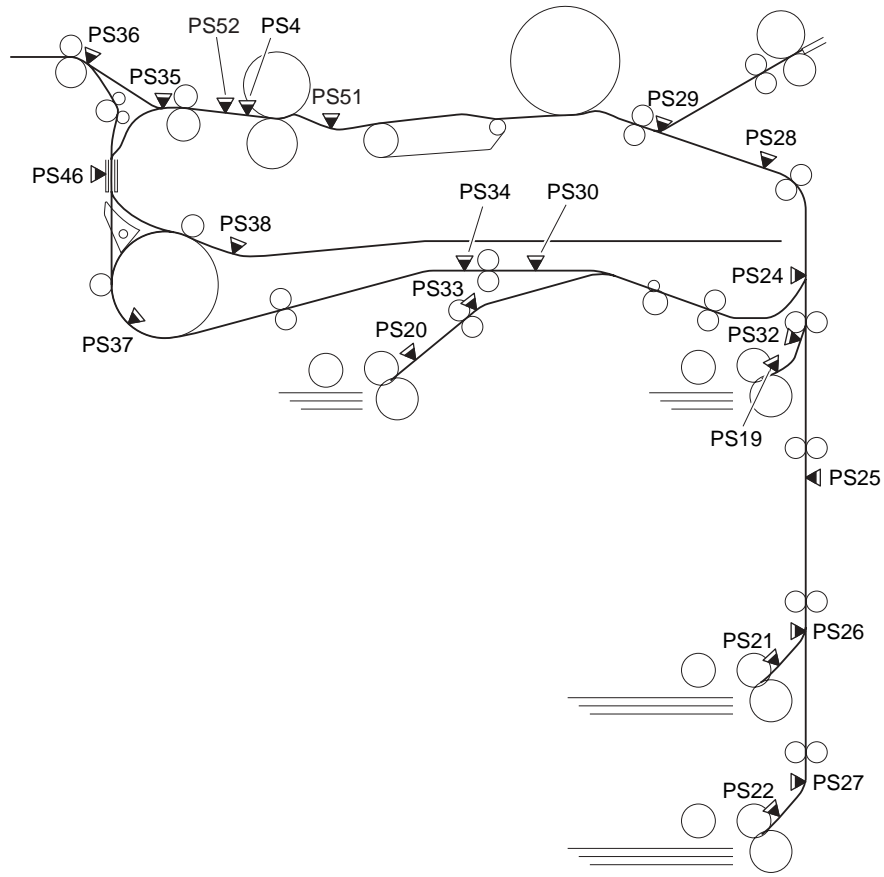

F-8-9

T-8-5

**Types of Jams**

Sensor	Notation	Delay jam	Stationary jam	Power-on stationary jam
Right deck retry sensor	PS19	yes	no	no
Left deck retry sensor	PS20	yes	no	no
Cassette 3 retry sensor	PS21	yes	no	no
Cassette 4 retry sensor	PS22	yes	no	no
Right deck pull-off sensor	PS32	yes	yes	yes
Left deck pull-off sensor	PS33	yes	yes	yes
Vertical path 1 sensor	PS24	yes	yes	yes
Vertical path 2 sensor	PS25	yes	yes	yes
Vertical path 3 sensor	PS26	yes	yes	yes
Vertical path 4 sensor	PS27	yes	yes	yes
Write check sensor	PS28	yes	yes	yes
Registration sensor	PS29	yes	yes	yes
Fixing inlet sensor	PS51	no	no	yes
Fixing claw jam sensor	PS4	no	yes	yes
Fixing outlet sensor	PS52	yes	no	yes
Inside delivery sensor	PS35	yes	yes	yes
Outside delivery sensor	PS36	yes	yes	yes
Reversal sensor 1	PS37	yes	yes	yes
Reversal sensor 2	PS38	yes	yes	yes
Duplexing paper sensor	PS34	yes	yes	yes

Sensor	Notation	Delay jam	Stationary jam	Power-on stationary jam
Duplexing pre-registration sensor	PS30	yes	yes	yes
Delivery assembly jam sensor	PS46	no	no	yes

**8.3.1.2 Jam History**

iR5065 / iR 5055 / iR5075 / iR5075N / iR5065N / iR5055N

The machine has a mechanism to keep a record of jams that occur inside it, permitting the service person to check its history of jams in service mode.

**SERVICE MODE:**

**COPIER>DISPLAY>JAM**

Use it to indicate jam data.

**COPIER>FUNCTION>CLEAR>JAM-HITS**

Use it to indicate the machine's jam history.

**8.3.2 Delay Jams**

**8.3.2.1 Cassette Pickup Assembly (right deck, left deck, cassette 3/4)**

iR5065 / iR 5055 / iR5075 / iR5075N / iR5065N / iR5055N

If the leading edge of paper does not reach the sensor within a specific period of time after the motor goes on, the machine will identify the condition as being a delay jam.

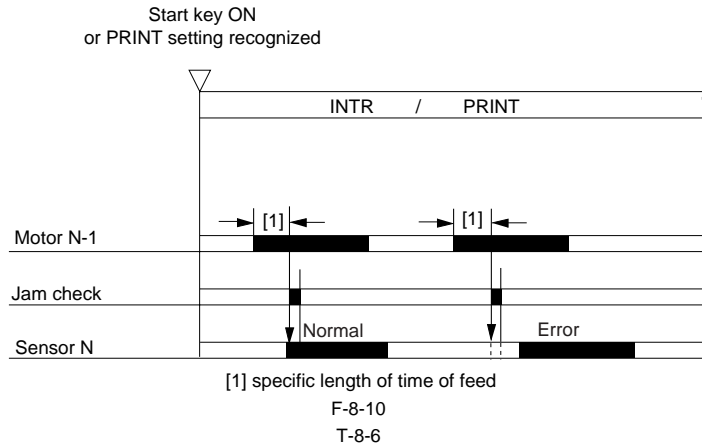

Pickup assembly	Motor N-1	Delay jam sensor N
right deck	right deck pickup motor(M11)	right deck retry sensor(PS19)
left deck	Left deck pickup motor(M24)	left deck retry sensor(PS20)
Cassette 3	Cassette 3/4 pickup motor(M12)	cassette 3 retry sensor(PS21)
Cassette 4	cassette 3/4 pickup motor(M12)	cassette 4 retry sensor(PS22)

**8.3.2.2 Other Delay Jam**

iR5065 / iR 5055 / iR5075 / iR5075N / iR5065N / iR5055N

The machine identifies a delay jam occurring outside its cassette/deck pickup assembly as follows:

The length of time during which paper is moved from the sensor N-1 to the appropriate delay jam sensor N is monitored. If the appropriate delay jam sensor N does not go on within a specific period of time after the sensor NB has gone on, the machine will identify the condition as being a delay jam.



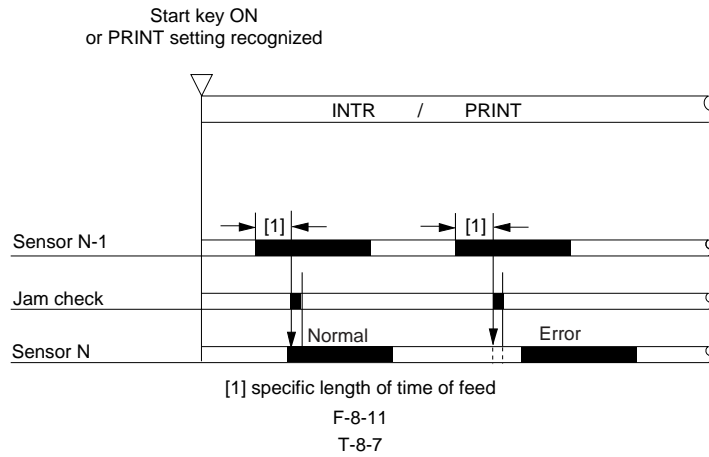

**Sensor**

- right deck pull-off sensor (PS32)
- left deck pull-off sensor (PS33)
- vertical path 1 sensor (PS24)
- vertical path 2 sensor (PS25)
- vertical path 3 sensor (PS26)
- vertical path 4 sensor (PS27)
- write check sensor (PS28)
- registration sensor (PS29)
- fixing outlet sensor (PS52)
- inside delivery sensor (PS35)
- outside delivery sensor (PS36)
- reversal sensor 1 (PS37)
- reversal sensor 2 (PS38)
- duplexing paper sensor (PS34)
- duplexing pre-registration sensor (PS30)

**8.3.3 Stationary Jams**

**8.3.3.1 Common Delay Jams**

iR5065 / iR 5055 / iR5075 / iR5075N / iR5065N / iR5055N

If the sensor N does not go off within a specific period of time after it has gone on, the machine will identify the condition as being a stationary jam.

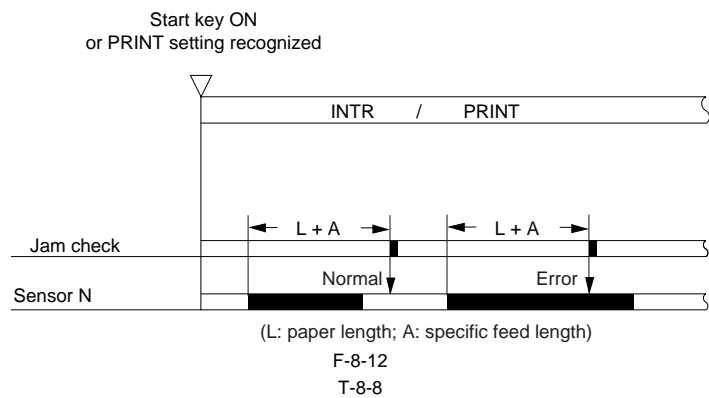

**Sensor**

- right deck pull-off sensor (PS32)
- left deck pull-off sensor (PS33)
- vertical path 1 sensor (PS24)
- vertical path 2 paper sensor (PS25)

**Sensor**

---

- vertical path 3 paper sensor (PS26)
- vertical path 4 paper sensor (PS27)
- write check sensor (PS28)
- registration sensor (PS29)
- fixing claw jam sensor (PS4)
- inside delivery sensor (PS35)
- outside delivery sensor (PS36)
- reversal sensor 1 (PS37)
- reversal sensor 2 (PS38)
- duplexing paper sensor (PS34)
- duplexing pre-registration sensor (PS30)

**8.3.3.2 Power-On Stationary Jam**

iR5065 / iR 5055 / iR5075 / iR5075N / iR5065N / iR5055N

The machine will identify a power-on stationary jam if paper exists over any of the following sensors when it starts initial multiple rotation at power-on:  
T-8-9

**Sensor**

---

- right deck pull-off sensor (PS32)
- left deck pull-off sensor (PS33)
- vertical path 1 sensor (PS24)
- vertical path 2 sensor (PS25)
- vertical path 3 sensor (PS26)
- vertical path 4 sensor (PS27)
- write check sensor (PS28)
- registration sensor (PS29)
- fixing inlet sensor (PS51)
- fixing claws jam sensor (PS4)
- fixing outlet sensor (PS52)
- inside delivery sensor (PS35)
- outside delivery sensor (PS36)
- reversal sensor 1 (PS37)
- reversal sensor 2 (PS38)
- duplexing paper sensor (PS34)
- duplexing pre-registration sensor (PS30)
- delivery assembly jam sensor (PS46)

**8.4 Cassette Pick-Up Unit**

---

**8.4.1 Lifter Operation (cassette 3/4)**

iR5065 / iR 5055 / iR5075 / iR5075N / iR5065N / iR5055N

When the cassette is pushed into the machine, the cassette open/closed sensor goes on and, at the same time, the pickup roller starts to move down. At this time, the light-blocking plate leaves the lifter sensor, causing the cassette lifter motor to go on and the lifter to move up. When the lifter moves up and the lifter sensor detects the surface of paper, its ascent stops.

When the open button of the cassette is pressed, the drive gear of the lifter becomes disengaged, letting the lifter to move down under its own weight.

T-8-10

	Cassette 3	Cassette 4
Cassette opening/closing	cassette 3 opening/closing	cassette 4 opening/closing

Detection	sensor (PS15)	sensor (PS16)
Lifter position detection	cassette 3 lifter sensor (PS17)	cassette 4 lifter sensor (PS18)
Paper detection	cassette 3 paper sensor (PS13)	cassette 4 paper sensor(PS14)
Paper level detection	cassette 3 paper level detection PCB	cassette 4 paper level detection PCB
	(variable resistor)	(variable resistor)
Lifter ascent limiter	---	---
drive motor	cassette 3 lifter motor (M20)	cassette 4 lifter motor(M21)

The following diagram shows the components of the cassette pickup unit:

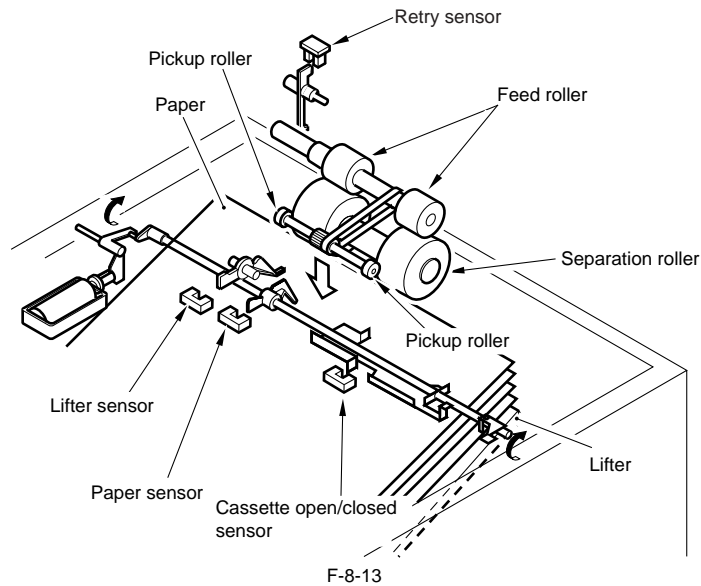

### 8.4.2 Detecting the Presence/Absence of Paper

iR5065 / iR 5055 / iR5075 / iR5075N / iR5065N / iR5055N

The presence/absence of paper inside the deck or the cassette is checked by the cassette paper sensor.

- Paper Present

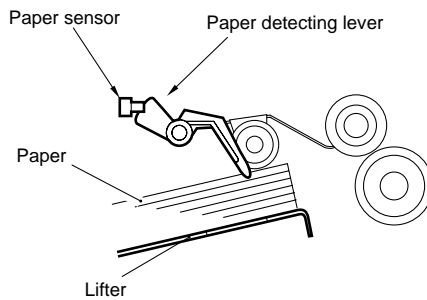

- Paper Absent

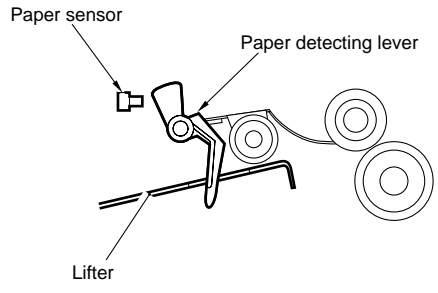

F-8-15

**8.4.3 Outline of the Paper Level Detection Mechanism**

iR5065 / iR 5055 / iR5075 / iR5075N / iR5065N / iR5055N

The machine indicates the amount of paper inside the deck and the cassette in terms of 4 levels (including absence of paper) on its control panel:

T-8-11

	3 bars	100% to about 50% of capacity
	2 bars	about 50% to about 10% of capacity
	1 bar	10% or less of capacity
	no bar	no paper

**8.4.4 Paper Level Detection (cassette 3/4)**

iR5065 / iR 5055 / iR5075 / iR5075N / iR5065N / iR5055N

The machine checks the amount of paper remaining based on the reading of a variable resistor that operates in conjunction with the movement of the lifter drive shaft.

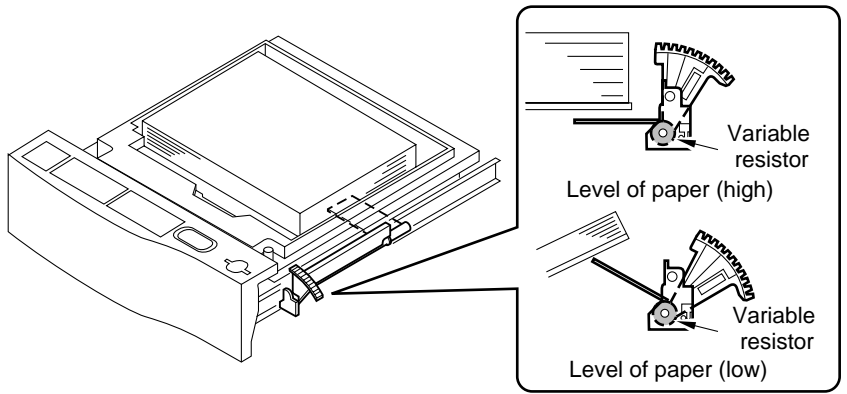

F-8-16

**SERVICE MODE:**

- COPIER> ADJUST> CST-ADJ> C3-LVOL**  
Indicates the value when 50 sheets of paper exist in cassette 3.
- COPIER> ADJUST> CST-ADJ> C3-HVOL**  
Indicates the value when 275 sheets of paper exist in cassette 3.
- COPIER> ADJUST> CST-ADJ> C4-LVOL**  
Indicates the value when 50 sheets of paper exist in cassette 4.
- COPIER> ADJUST> CST-ADJ> C4-HVOL**  
Indicates the value when 275 sheets of paper exist in cassette 4.

**8.4.5 Identifying the Size of Paper (cassette 3/4)**

iR5065 / iR 5055 / iR5075 / iR5075N / iR5065N / iR5055N

**Outline**

The machine uses the paper size sensor mounted to the rear of the cassette holder to identify the size of paper inside the cassette. When the cassette is slid into the cassette holder, the paper size sensor is pushed by the boss on the cassette, permitting the machine to detect the width and the length of paper. The DC controller PCB identifies the size of the paper with reference to the combination of its width and length, and communicates the result of identification to the controller unit and the reader unit.

The boss pushing the paper size sensor works in conjunction with the guide plate inside the cassette, and its location is determined when the guide plate is set to suit a specific paper size.

**Identifying the Size Paper**

The paper length sensor consists of 2 photointerrupters, and the combination of its 2 outputs is used to find out the length of paper. The paper width sensor, on the other hand, is a variable resistor, and the machine refers to the reading (resistance) of the sensor to find out the width of paper.

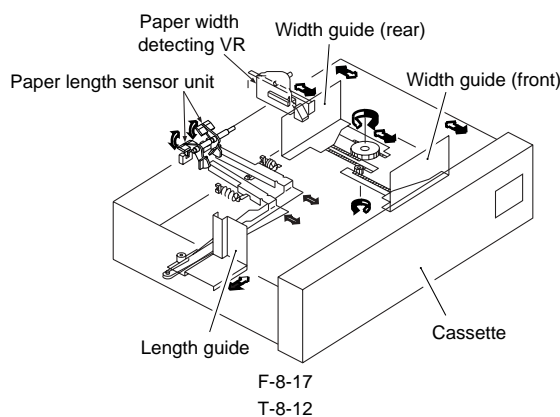

	Cassette 3	Cassette 4
Paper length detection	UN18	UN19
Paper width detection	UN16	UN17

### 8.4.6 Markings on the Width Guide Rail

iR5065 / iR 5055 / iR5075 / iR5075N / iR5065N / iR5055N

The width guide rail mounted inside the cassette is provided with paper size detecting holes identified by means of markings from A through M. If the user reports skew movement, for instance, ask him/her to communicate the marking so that you will know if the paper width is correctly set. (The purpose of these markings is not disclosed to the user.)

T-8-13

Marking	Paper	Remarks
A	STMT-R	
B	A5-R	
C	B5-R	
D	KLGL-R	
E	GLTR-R	
F	G-LGL	U3
G	A4-R	
H	LGL/LTR-R	
I	FLSC	U2
J	B4/B5	
K	G-LTR	U1
L	279.4 x 431.8mm (11" x 17" ) / LTR	U4
M	A3/A4	

### 8.4.7 Paper Size

iR5065 / iR 5055 / iR5075 / iR5075N / iR5065N / iR5055N

The CPU on the DC controller PCB identifies the size of paper used based on paper width and paper length. The result of identification is communicated to the controller unit.

Paper width sensor (slice level) Unit: mm	Paper length sensor	PS102/ PS104	PS101/ PS103	PS102/ PS104	PS101/ PS103	PS102/ PS104	PS101/ PS103	PS102/ PS104	PS101/ PS103
	Signal	SZ 2	SZ 1	SZ 2	SZ 1	SZ 2	SZ 1	SZ 2	SZ 1
	ON/OFF	0	0	0	1	1	0	1	1
288.5		A4		-	A3		-		
		(U4)		-	279.4 x 431.8mm (11"x17")		-		
273.7		(U1)		-	-	-	-		
261.8		B5		-	B4		-		
238.0		STMT		LTRR		LGL		(U2)	
212.9		A5		A4R		-		(U3)	
206.6		G-LTRR		-		-			
196.6		K-LGLR		-		-			
186.0		B5R		-		-			
165.2		A5R		-		-			
144.1		STMTR		-		-			

F-8-18

T-8-14

The following sizes are grouped and specified in service mode. A size identified by an asterisk is a default paper size as selected at time of shipment from the factory.

Group	Size
U1	* G-LTR
	K-LGL
U2	* FOOLSCAP
	OFFICIO
	E-OFFI
	A-OFFI
	M-OFI
U3	* G-LGL
	FOLIO
	AUS-FLS
	* LTR
	A-LTR

**SERVICE MODE:**

**COPIER> OPTION> CST> CST-U1**

31: G-LTR \*, 22: K LGL

**COPIER> OPTION> CST> CST-U2**

24: FLSC \*, 26: OFI, 27: E-OFI, 36: A-OFI, 37: M-OFI

**COPIER> OPTION> CST> CST-U3**

34: G-LGL \*, 35: FOLI, 25: A-FLS

**COPIER> OPTION> CST> CST-U4**

18: LTR \*, 29: A-LTR

\*: factory setting

**COPIER> ADJUST> CST-ADJ> C3-STMTR**

Use it to change the paper width basic value for STMTR in cassette 3.

**COPIER> ADJUST> CST-ADJ> C3-A4R**

Use it to change the paper width basic value A4R in cassette 3.

**COPIER> ADJUST> CST-ADJ> C4-STMTR**

Use it to change the paper width basic value for STMTR in cassette 4.

**COPIER> ADJUST> CST-ADJ> C4-A4R**

Use it to change the paper width basic value for A4 in cassette 4.

- Paper Types That May Be Used for the Machine

T-8-15

Name	Notation	Size (vertical x horizontal; mm)
A3	A3	(297 +/- 1) x (420 +/- 1)
A4R	A4R	(210 +/- 1) x (297 +/- 1)

Name	Notation	Size (vertical x horizontal; mm)
A4	A4	(297 +/- 1) x (210 +/- 1)
A5	A5	(210 +/- 1) x (148.5 +/- 1)
A5R	A5R	(148.5 +/- 1) x (210 +/- 1)
B4	B4	(257 +/- 1) x (364 +/- 1)
B5R	B5R	(182 +/- 1) x (257 +/- 1)
B5	B5	(257 +/- 1) x (182 +/- 1)
11 x 17	11 x 17	(279 +/- 1) x (432 +/- 1)
LTRR	LTRR	(216 +/- 1) x (279 +/- 1)
LTR	LTR	(279 +/- 1) x (216 +/- 1)
STMT	STMT	(216 +/- 1) x (139.5 +/- 1)
STMR	STMTR	(139.5 +/- 1) x (216 +/- 1)
LEGAL	LGL	(216 +/- 1) x (356 +/- 1)
Korean Government	K-LGL	(265 +/- 1) x (190 +/- 1)
Korean Government R	K-LGLR	(190 +/- 1) x (265 +/- 1)
FOOLSCAP	FLSC	(216 +/- 1) x (330 +/- 1)
Australian Australian Foolscap	A-FLS	(206 +/- 1) x (337 +/- 1)
OFICIO	OFI	(216 +/- 1) x (317 +/- 1)
Ecuadorian Officio	E-OFI	(220 +/- 1) x (320 +/- 1)
Bolivian Officio	B-OFI	(216 +/- 1) x (355 +/- 1)
Argentine LTR	A-LTR	(280 +/- 1) x (220 +/- 1)
Argentine LTRR	A-LTRR	(220 +/- 1) x (280 +/- 1)
Government LTR	G-LTR	(267 +/- 1) x (203 +/- 1)
Government LTRR	G-LTRR	(203 +/- 1) x (267 +/- 1)
Argentine LGL	A-LGL	(220 +/- 1) x (340 +/- 1)
Government LGL	G-LGL	(203 +/- 1) x (330 +/- 1)
FOLIO	FOLI	(210 +/- 1) x (330 +/- 1)
Argentine Officio	A-OFI	(220 +/- 1) x (340 +/- 1)
Mexico Officio	M-OFI	(216 +/- 1) x (341 +/- 1)

## 8.5 Manual Feed Pickup Unit

### 8.5.1 Pickup Operation

iR5065 / iR 5055 / iR5075 / iR5075N / iR5065N / iR5055N

The presence/absence of paper in the manual feed tray is detected by the manual feed paper sensor (PS23). The manual feed pull-off roller is operated by the drive coming from the main motor by way of the manual feed pickup clutch (CL3).

When the clutch engages, the holding plate solenoid goes on so that the manual feed holding plate moves up.

In response, the gear of the feed roller receives the drive of the main motor, causing the feed roller to make a single rotation for movement of paper.

While the feed roller is rotating, the paper is moved by the manual feed roller as far as the registration roller.

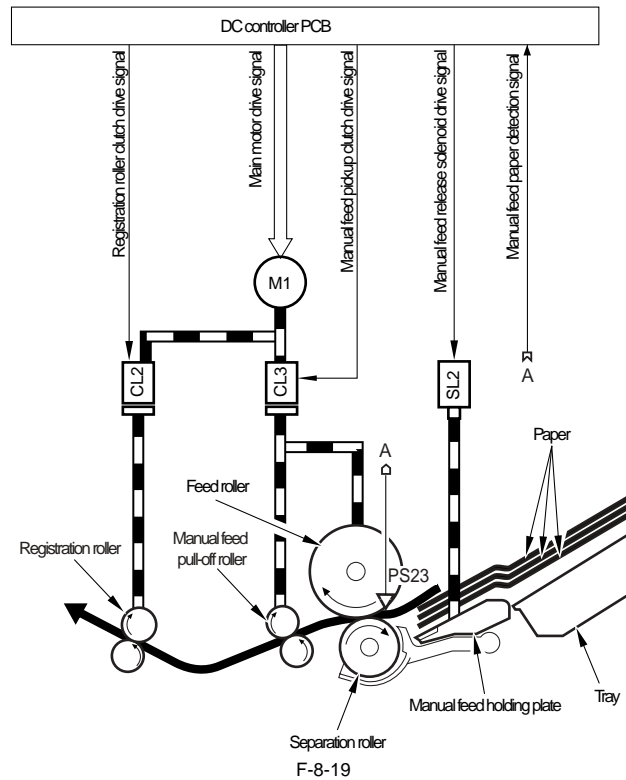

F-8-19

**8.5.2 Detecting the Size of Paper in the Manual Feed Tray**

iR5065 / iR 5055 / iR5075 / iR5075N / iR5065N / iR5055N

The user may set the side guide of the manual feed tray to suit the width of paper he/she is using. The reading of the variable resistor that operates in conjunction with the movement of the side guide is monitored by the DC controller PCB for detection of paper width. The machine does not have a specific mechanism to detect the length of paper, requiring the user to specify it. The width that has been detected is used when the machine executes laser exposure control. The machine refers to the length of time during which the manual feed paper sensor (PS23) remains on to find out the length of paper when the manual feed tray is used. If the variable resistor has been replaced, the paper width basic value must be registered newly.

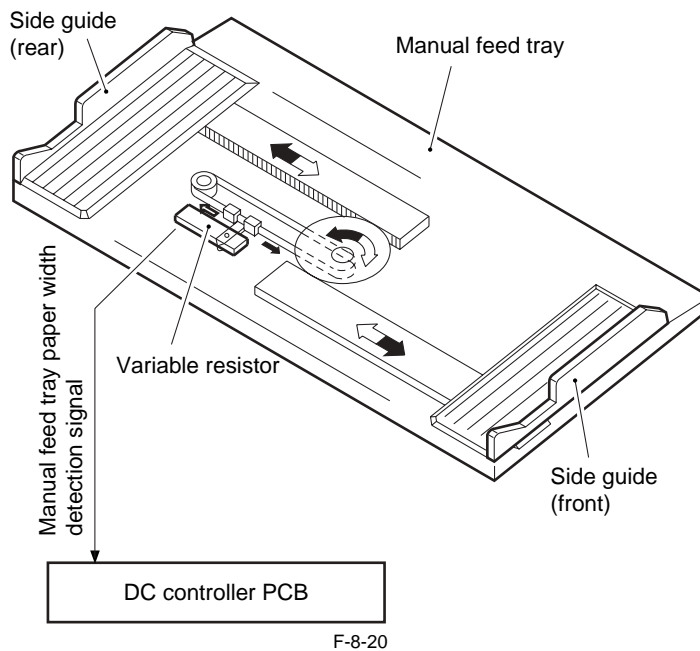

F-8-20

**SERVICE MODE:**

**COPIER> ADJUST> CST-ADJ> MF-A4R**

Use it to change the paper width basic value for A4R in the manual feed tray.

**COPIER> ADJUST> CSRT-ADJ> MF-A6R**

Use it to change the paper width basic value for A6R in the manual feed tray.

**COPIER> ADJUST> CST-ADJ> MF-A4**

Use it to change the paper width basic value for A4 in the manual feed tray.



## 8.6 Deck

### 8.6.1 Lifter Operation (right/left deck)

iR5065 / iR 5055 / iR5075 / iR5075N / iR5065N / iR5055N

When the deck is slid into the machine, the deck open/closed sensor goes on and, at the same time, the pickup roller starts to move down. While all this goes on, the light-blocking plate leaves the lifter sensor, causing the deck lifter motor to go on and the lifter to move up.

The lifter stops to move up when the lifter sensor detects the surface of paper. The left/right deck, further, is equipped with a limiter to make sure that the lifter stops before it moves past the lifter sensor.

When the open button of the deck or the cassette is pushed, the drive gear of the lifter becomes disengaged, letting the lifter to move down under its own weight.

T-8-16

	Right deck	Left deck
Cassette opening/closing	right deck	left deck
Detection	open/closed sensor (PS5)	open/closed sensor (PS9)
Lifter position detection	Right deck lifter sensor(PS6)	left deck lifter sensor (PS10)
Paper detection	right deck paper sensor (PS7)	left deck paper sensor (PS11)
Paper level sensor	right deck paper level upper sensor (PS47)	left deck paper level upper sensor (PS49)
	right deck paper level lower sensor (PS48)	left deck paper level lower sensor(PS50)
Lifter upper limiter	right deck limit sensor (PS8)	left deck limit sensor(PS12)
Drive motor	right deck lifter motor (M4)	left deck lifter motor(M5)

The following diagram shows the components of the deck:

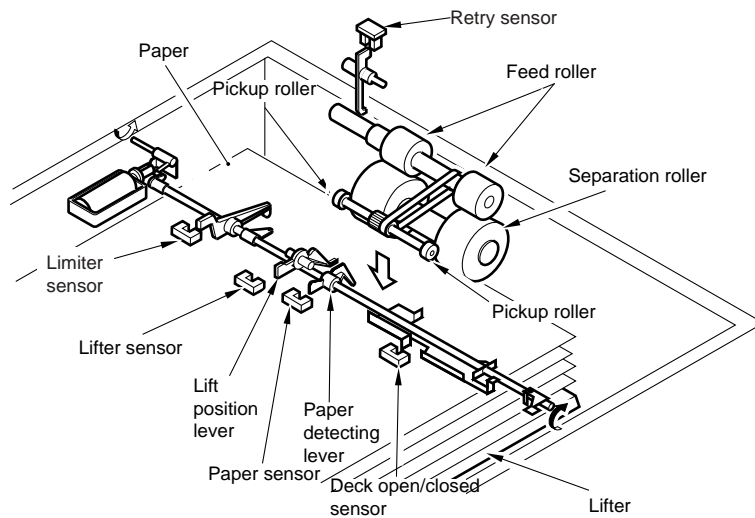

F-8-21

### 8.6.2 Lifter Limiter (right/left deck) Control Circuit

iR5065 / iR 5055 / iR5075 / iR5075N / iR5065N / iR5055N

When the CPU on the DC controller PCB generates the motor drive signal, the lifter motor in response starts to rotate to move the lifter. When the deck reaches the lifter sensor, the deck lifter detection signal arrives at the CPU, causing the CPU to stop the deck lifter drive motor.

The machine is equipped with a deck limit sensor to make sure that the lifter will not go awry. When the surface of paper reaches the deck limit sensor, the limit signal arrives at the DC controller PCB to cut off the drive signal, thereby stopping the limit motor.

The following block diagram shows the control circuit:

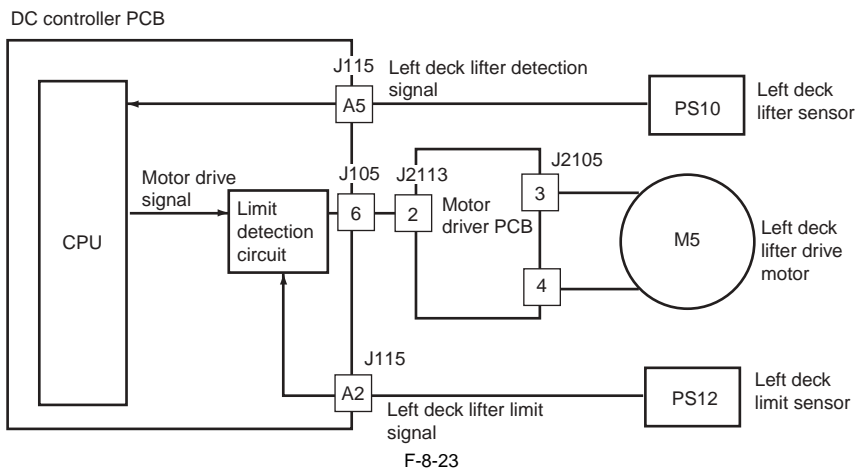
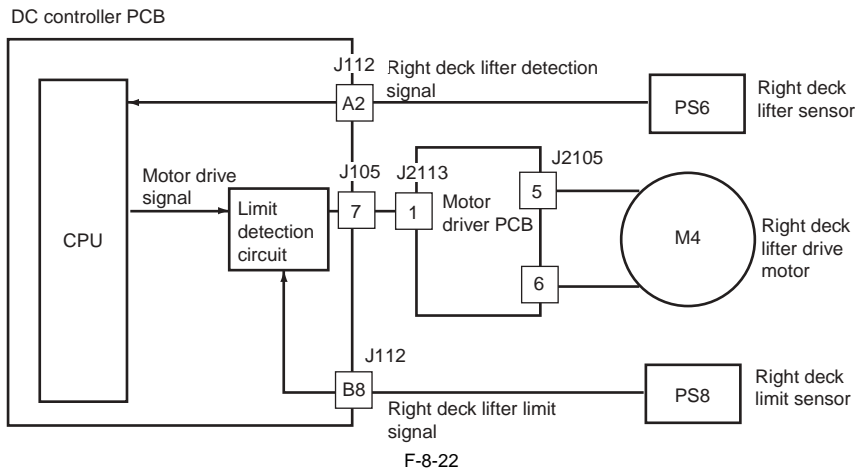

### 8.6.3 Detecting the Presence/Absence of Paper

iR5065 / iR 5055 / iR5075 / iR5075N / iR5065N / iR5055N

The presence/absence of paper inside the deck or the cassette is checked by the cassette paper sensor.  
 - Paper Present

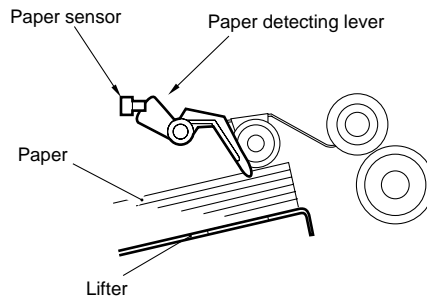

F-8-24

- Paper Absent

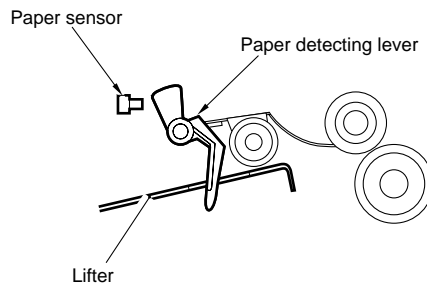





F-8-25

### 8.6.4 Outline of Paper Level Detection

iR5065 / iR 5055 / iR5075 / iR5075N / iR5065N / iR5055N

The machine indicates the amount of paper inside the deck and the cassette in terms of 4 levels (including absence of paper) on its control panel:

T-8-17		
	3 bars	100% to about 50% of capacity
	2 bars	about 50% to about 10% of capacity
	1 bar	10% or less of capacity
	no bar	no paper

### 8.6.5 Paper Level Detection Operation (right/left deck)

iR5065 / iR 5055 / iR5075 / iR5075N / iR5065N / iR5055N

The machine uses 2 sensors to check the position of the deck bottom plate, and checks the level of paper based on the combination of sensor states (on/off). The machine uses a special sensor to check the presence/absence of paper.

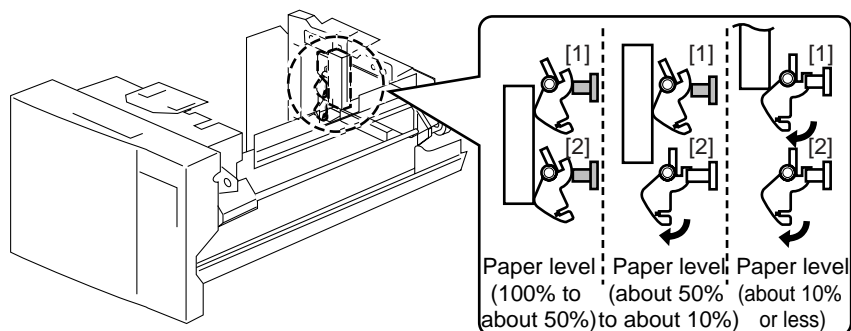

F-8-26  
T-8-18

	Right deck			Left deck		
Paper level	[1] sensor (PS47)	[2] sensor (PS48)	sensor (PS7)	[1] sensor (PS49)	[2] sensor (PS50)	sensor (PS11)
100% to about 50%	ON	ON	ON	ON	ON	ON
about 50% to about 10%	OFF	ON	ON	OFF	ON	ON
about 10% or less	OFF	OFF	ON	OFF	OFF	ON
no paper	OFF	OFF	OFF	OFF	OFF	OFF

### 8.6.6 Identifying the Size of Paper (right/left deck)

iR5065 / iR 5055 / iR5075 / iR5075N / iR5065N / iR5055N

The right/left deck does not possess a mechanism to detect the size of paper, and the machine finds out the size of paper as follows: (A4, B5, LTR)

[1] The position of the paper size guide plate of the cassette is changed.

[2] A paper size is registered in service mode.

#### SERVICE MODE:

##### COPIER> OPTION> CST> P-SZ-C1

Use it to specify a paper size for the right deck.

Settings:

6: A4, 15: B5, 18: LTR

##### COPIER> OPTION> CST> P-SZ-C2

Use it to specify a paper size for the left deck.

Settings:

6: A4, 15: B5, 18: LTR

## 8.7 Registration Unit

### 8.7.1 Outline

iR5065 / iR 5055 / iR5075 / iR5075N / iR5065N / iR5055N

The registration clutch serves to make sure that the print paper and the image on the drum will match at a specific point. The timing at which the registration roller clutch goes on may be varied in service mode (ADJUST>FEED-ADJ>REGIST).

8.7.2 Control System

iR5065 / iR 5055 / iR5075 / iR5075N / iR5065N / iR5055N

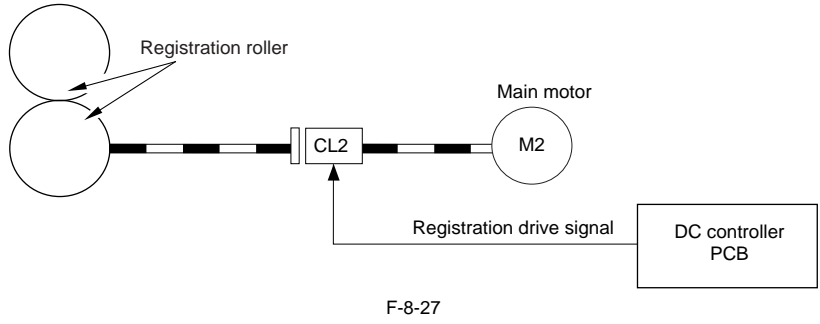

8.8 Duplex Feeding Unit

8.8.1 Moving the Paper to the Reversing Assembly After Printing on the 1st Side

iR5065 / iR 5055 / iR5075 / iR5075N / iR5065N / iR5055N

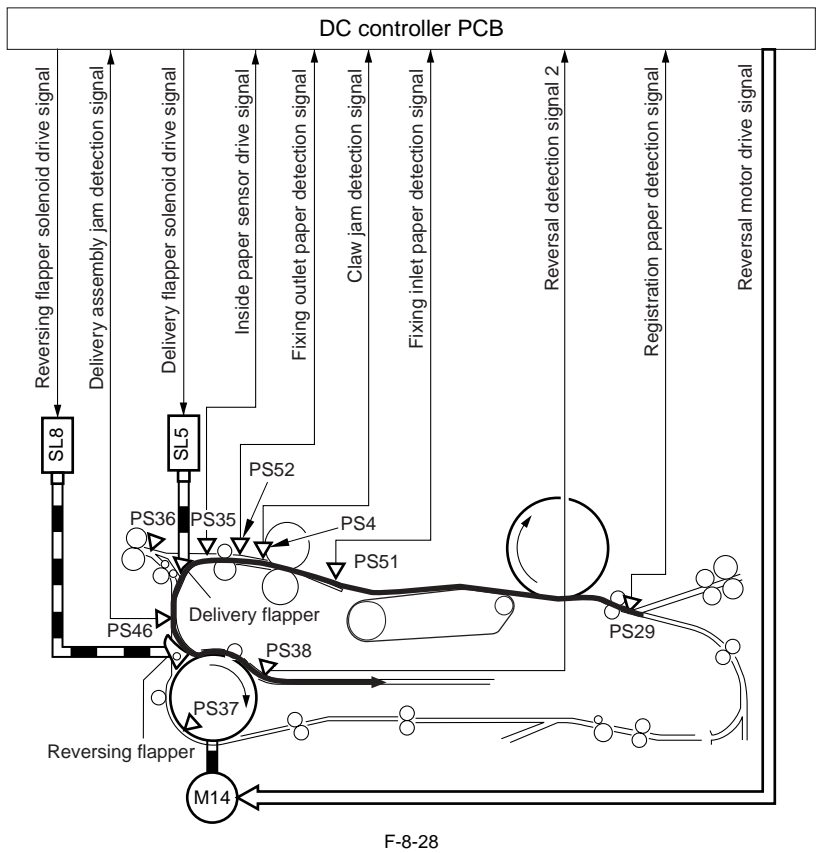

8.8.2 Moving the Paper to the Duplexing Feed Assembly From the Reversing Assembly

iR5065 / iR 5055 / iR5075 / iR5075N / iR5065N / iR5055N

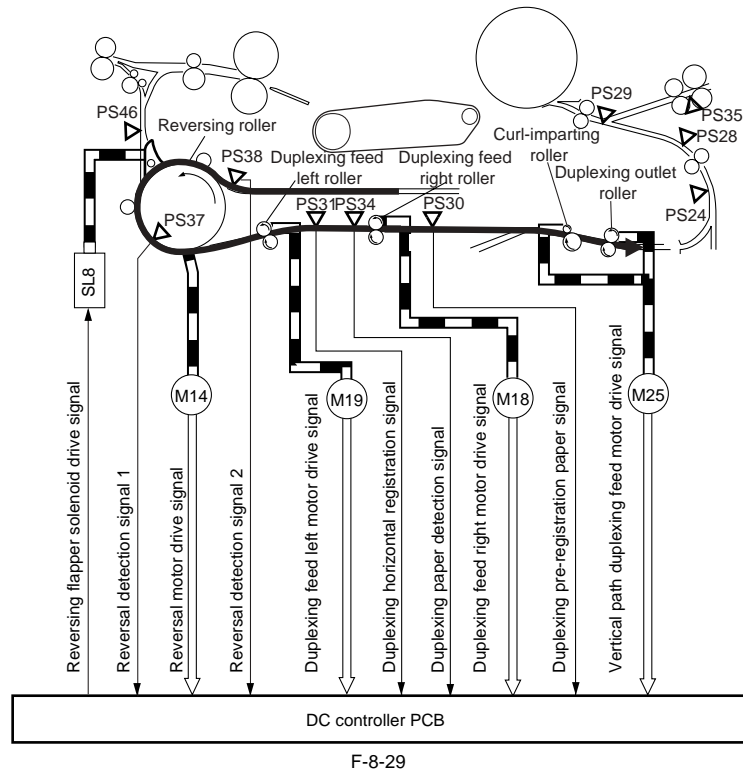

F-8-29

### 8.8.3 Outline

iR5065 / iR 5055 / iR5075 / iR5075N / iR5065N / iR5055N

The paper path for the 1st side of a duplex print is formed when the reversing flapper solenoid (SL8) goes on to move up the reversing flapper. When printing on the 1st side is done and the leading edge of paper reaches the delivery assembly jam detection sensor (PS4), the reversing flapper solenoid goes on. When the delivery assembly jam sensor (PS46) goes on and the paper arrives at a specific point, the reversal motor (M14) starts to rotate to move the paper to the duplexing reversing assembly. When the paper reaches the reversal sensor 2 (PS38) and then a specific point, the reversal motor (M14) stops to rotate so that the paper is kept on hold at the reversing assembly.

Thereafter, when the reversal motor (M14) starts to rotate in reverse, the paper in the reversing assembly is moved toward the duplexing wait point by the work of the duplexing feed left/right roller, which is operated by the drive from the duplexing feed left/right motor (M19, M18). When the paper reaches the duplexing repickup point (before 40mm of the curling roller), the paper stops and the horizontal registration operation is executed.

The paper is then moved to the duplexing wait point as soon as the duplexing feed left/right motor (M19, M18) starts to rotate again.

#### MEMO:

The paper is not arched. (both case thick paper mode and plain paper mode)

### 8.8.4 Sequence of Printing Operation

iR5065 / iR 5055 / iR5075 / iR5075N / iR5065N / iR5055N

A4, 4 Originals, Duplexing

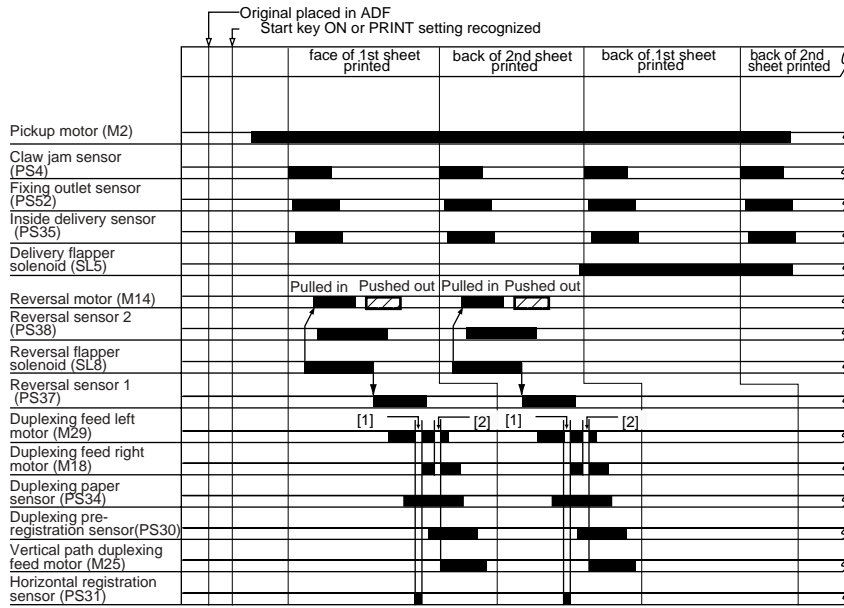

[1] stops for arching at the duplexing feed right roller.  
[2] stops to control the sheet-to-sheet distance at the duplexing wait point.

F-8-30

### 8.8.5 Outline of Through-Path Operation

iR5065 / iR 5055 / iR5075 / iR5075N / iR5065N / iR5055N

The through-path mechanism is used to move paper to the duplexing feed assembly after fixing (and after the paper has been moved to the reversing assembly by the work of the reversing flapper).

The machine is designed to reorder pages in its memory for printing, being free of the need to print originals in sequence and being, therefore, able to reduce the time during which paper is kept on hold, ultimately bringing about faster duplexing operation. As many as 2 sheets of paper may exist at once between the registration sensor and the duplex paper sensor.

#### SERVICE MODE:

COPIER> ADJUST> FEED-ADJ> ADJ-REFE

Use it to adjust the write start position in main scanning direction at time of re-pickup.  
(-50 to 50 mm)

### 8.8.6 Through-Path Operation

iR5065 / iR 5055 / iR5075 / iR5075N / iR5065N / iR5055N

The following cites through-path operation when making duplex prints of 10 originals:

1. The 1st sheet is picked up from the right deck.

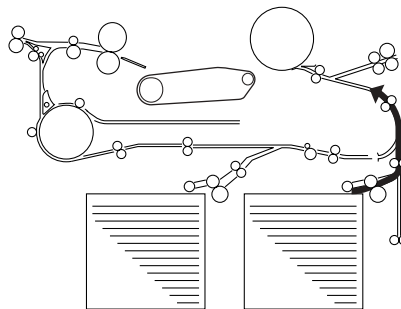

F-8-31

2. The 1st side is printed on the 1st sheet.  
The 2nd sheet is picked up.

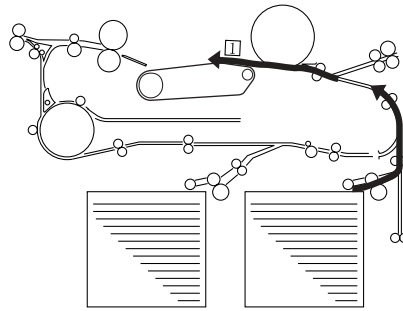

F-8-32

3. The 3rd side is printed on the 2nd sheet.  
The 1st sheet is moved to the reversing assembly.  
The 3rd sheet is picked up.

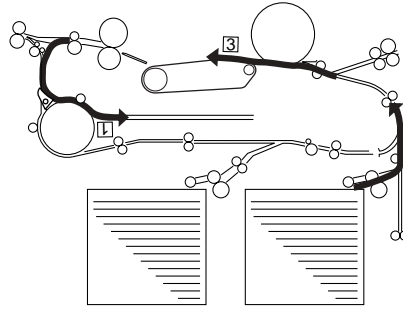

F-8-33

4. The 1st sheet is moved to the duplexing feed assembly.

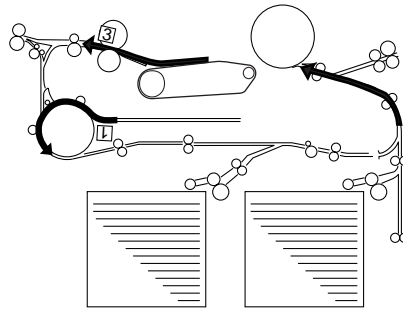

F-8-34

5. The 1st sheet is moved to the duplexing wait point.  
The 2nd sheet is moved to the reversing assembly.  
The 5th side is printed on the 3rd sheet.

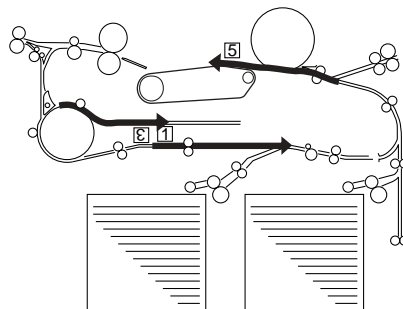

F-8-35

6. The 1st sheet is re-picked up at the duplexing wait point.  
The 2nd sheet is moved to the duplexing feed assembly.

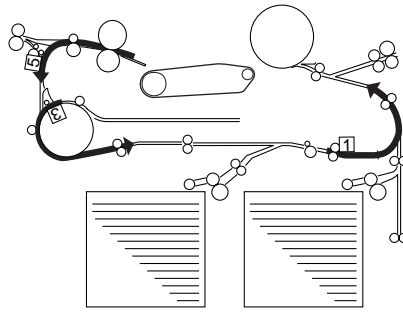

F-8-36

7. The 2nd side is printed on the 1st sheet.  
 The 2nd sheet is moved to the duplexing wait point.  
 The 4th sheet is picked up.

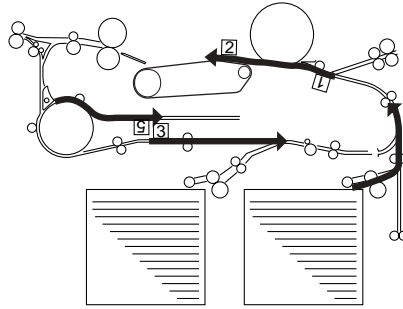

F-8-37

8. The 7th side is printed on the 4th sheet, and the 1st sheet is delivered.

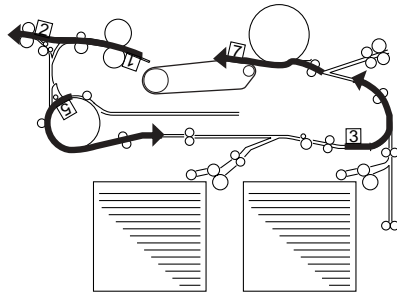

F-8-38

9. The 4th side is printed on the 2nd side, and the 3rd sheet is kept on hold at the duplexing wait point.  
 The 5th sheet is picked up.

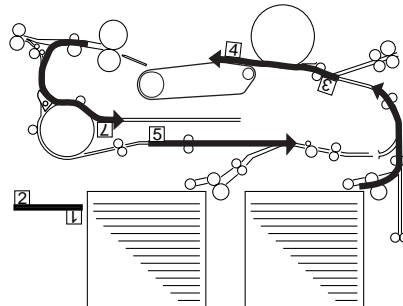

F-8-39

10. The 2nd sheet is delivered.  
 The 9th side is printed on the 5th sheet.

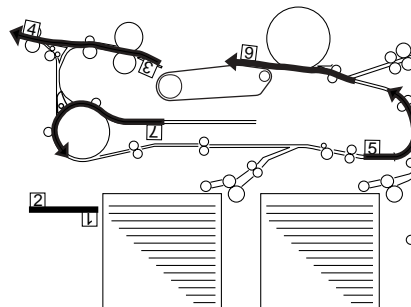

F-8-40



11. The 6th side is printed on the 3rd sheet.  
 The 4th sheet is kept on hold at the duplexing wait point.

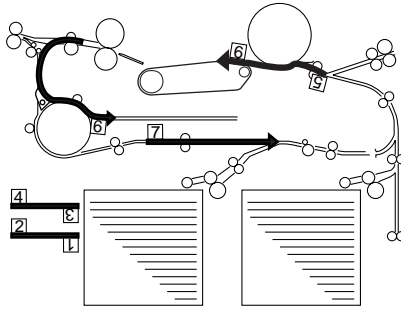

F-8-41

12. The 3rd sheet is delivered.

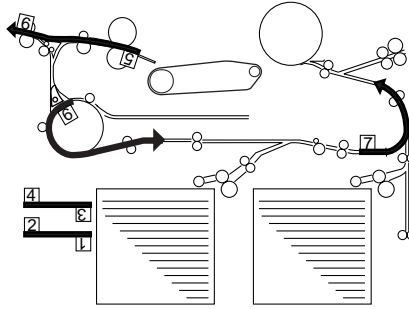

F-8-42

13. The 8th side is printed on the 4th sheet.

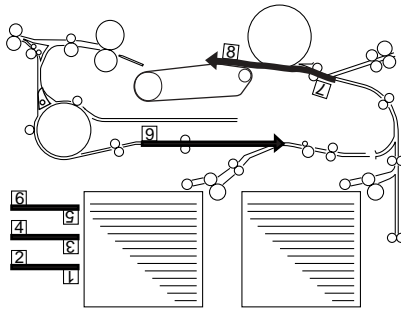

F-8-43

14. The 4th sheet is delivered, and the 10th side is printed on the 5th sheet.

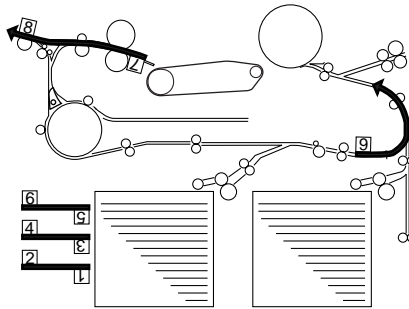

F-8-44

15. The 5th sheet is delivered.

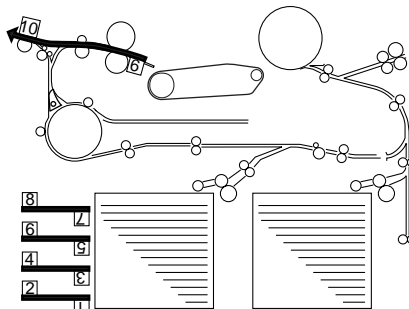

F-8-45

### 8.8.7 Outline of Horizontal Registration Position

iR5065 / iR 5055 / iR5075 / iR5075N / iR5065N / iR5055N

T-8-19

Paper position detection	duplexing horizontal registration sensor (PS31)
Timing of start of detection	after duplexing paper sensor (PS34) goes on
Source of drive	duplexing horizontal registration motor (M16)
Position measurement	by controlling pulses of duplexing horizontal registration motor (1 pulse = about 0.16 mm)
Related service mode	COPIER> ADJUST> FEED-ADJ> ADJ-REFE

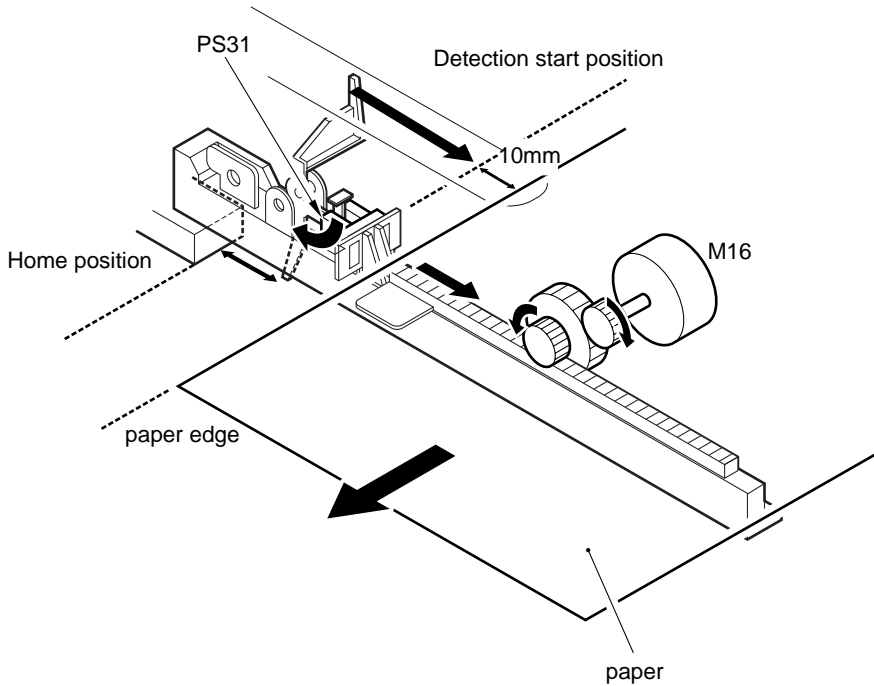

F-8-46

### 8.8.8 Horizontal Registration Position Detection Operation

iR5065 / iR 5055 / iR5075 / iR5075N / iR5065N / iR5055N

The machine executes home position detection of the duplexing horizontal registration sensor when the main power switch is turned on, when jam recovery is started, or when the front cover is closed. The registration sensor goes on, and moves to the start position (A4 detection position). When the paper moves from the duplexing feed assembly and reaches the duplex paper sensor (PS34), the horizontal registration motor (M16) goes on, and the duplex horizontal registration sensor (PS31) starts to check the edge of paper while the paper stops at the duplexing repickup point and for each duplexing session. The machine checks the paper width indicated by the slide guide of the manual feed tray assembly and the cassettes size when the registration sensor goes on, to determine the point at which detection is to be started (a point about 10 mm from the edge of paper assuming ideal movement of paper). The start position is used as the point of reference, and the machine identifies the paper position taking into account the likely displacement based on the number of drive pulses from the motor (1 pulse = about 0.16 mm).

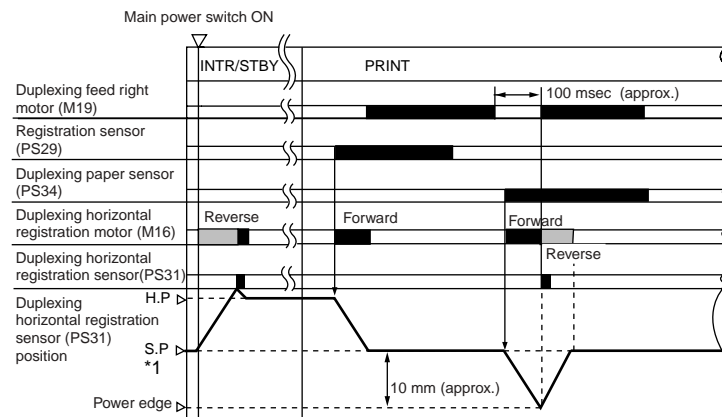

F-8-47

\*1: The edge of paper and the contact with the sensor are detected in the absence of the light-blocking plate.  
 \*2: The start position (SP) varies as the paper edge position varies depending on the size of paper.

HP: start position of the duplexing horizontal registration sensor.  
 SP: start position of the duplexing horizontal registration sensor.

## 8.9 Delivery

### 8.9.1 Reversal Delivery Operation

iR5065 / iR 5055 / iR5075 / iR5075N / iR5065N / iR5055N

The machine offers both face-up delivery and face-down delivery.

T-8-20

Delivery mode	Operation mode
Face-up	- making multiple prints of a single original
	- for the following, when the manual feed tray is used as the source of paper: with a default paper size selected and paper other than plain paper used
Face-down	- operation modes other than the above

The following shows the operation of the machine at time of reversal delivery in face-down delivery mode.

1. The sheet is moved to the duplexing feed assembly.

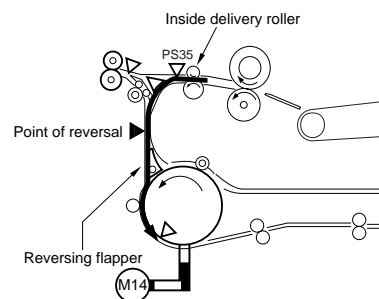

F-8-48

2. The inside delivery sensor (PS35) goes on and the paper moves over a specific distance; then, the reversal motor (M14) goes on to stop the trailing edge of paper at the point of reversal, timed to coincide with the activation of the reversal sensor 1 (PS37).

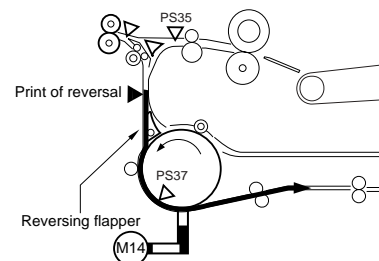

F-8-49

3. The reversal motor (M14) starts to rotate once again, and the trailing edge of paper is moved in the direction of delivery.

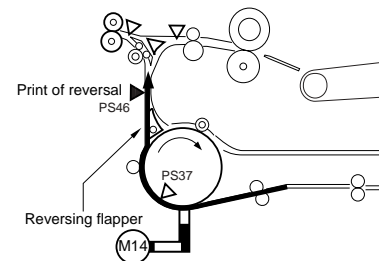

F-8-50

4. When the trailing edge of paper moves past the reversing roller coinciding with the activation of the outside delivery sensor (PS36), the reversal motor (M14) stops. The delivery motor (M13) starts to rotate to move the paper to the outside delivery roller, which discharges the paper to the outside of the machine.

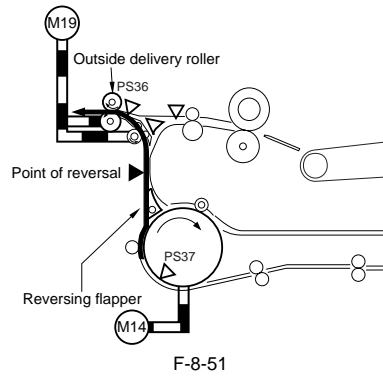

## 8.10 Cassette Heater

### 8.10.1 Timing of the Cassette Heater Supplied with Power

iR5065 / iR 5055 / iR5075 / iR5075N / iR5065N / iR5055N

The following shows the timing of the cassette heater supplied with power:

T-8-21

Operation mode	Switch combination			Cassette heater unit
	Main power switch	Environment switch	Cassette heater switch	
Main switch OFF	no	no	---	no
	no	yes	no	no
	no	yes	yes	yes
Standby / Cover open and close	yes	---	yes	yes
	yes	---	no	no
Copy / Print	yes	---	yes	yes
	yes	---	no	yes
Sleep mode	yes	yes	yes	yes
	yes	yes	no	no
	yes	no	---	no

yes: Heater ON  
no: Heater OFF  
---: Heater ON or OFF

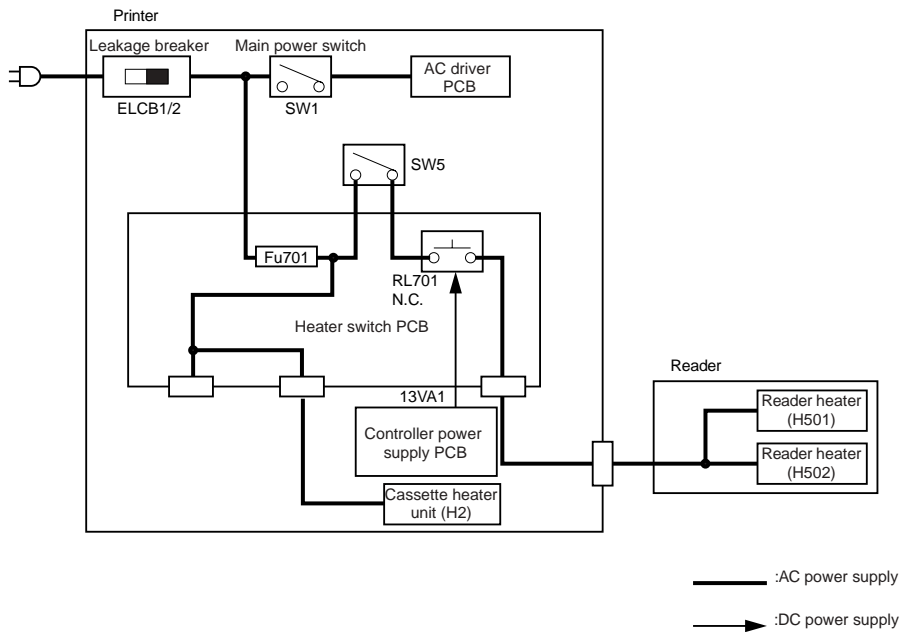

## 8.11 Parts Replacement Procedure

### 8.11.1 Pickup Roller

#### 8.11.1.1 Before Removing the Pickup Roller

iR5065 / iR 5055 / iR5075 / iR5075N / iR5065N / iR5055N

- 1) Remove the right deck pickup assembly. (page 8-35)Reference[Removing the Right Deck Pickup Assembly]
- 2) Remove the cassette pickup assembly. (page 8-31)Reference[Removing the Cassette 3/4 Pickup Assembly]
- 3) Remove the left deck pickup assembly. (page 8-35)Reference[Removing the Left Deck Pickup Assembly]

#### 8.11.1.2 Removing the Pickup Roller

iR5065 / iR 5055 / iR5075 / iR5075N / iR5065N / iR5055N

- 1) Remove the pickup roller [2] in the direction of the arrow.  
- 2 resin E-rings [1]

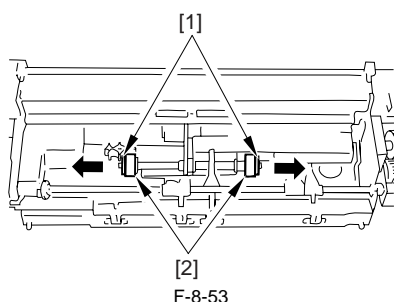

#### 8.11.1.3 Points to Note When Mounting the Pickup Roller

iR5065 / iR 5055 / iR5075 / iR5075N / iR5065N / iR5055N

⚠The direction of the mounting pickup roller  
The pickup roller may be mounted by reversing the steps used to remove it; however, be sure to keep the following in the mind.

- The roller used at the front and the rear of the machine is not compatible.
- When mounting the pickup roller used at the front of the machine [1], make sure the round mark [2] and the punch mark [3] found on the side of the roller are toward the front of the machine.

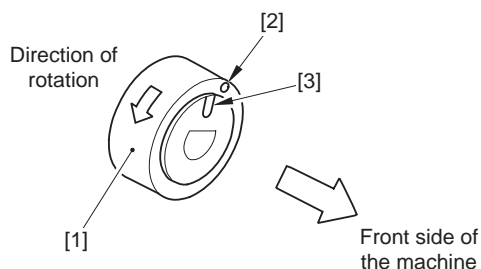

- When mounting the pickup roller used at the rear of the machine [1], make sure the punch mark [2] is at the rear of the machine.

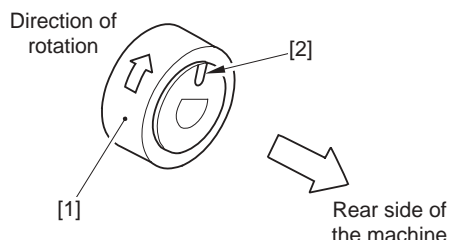

### 8.11.2 Cassette Pickup Assembly

#### 8.11.2.1 Removing the Cassette 3/4 Pickup Assembly

iR5065 / iR 5055 / iR5075 / iR5075N / iR5065N / iR5055N

The steps to remove the cassette 3 pickup assembly and the cassette 4 pickup assembly are the same.

- 1) Slide out the cassette 3/4.
- 2) Open the right door unit (rear).



An attempt to remove the pickup assembly without removing the cassette causes the lifter get trapped and may hold the pickup assembly from sliding out.

- 3) Disconnect the connector [3].  
- 1 screw [1]  
- 1 connector cover [2]
- 4) Remove the cassette 3/4 assembly [5].  
- 3 screws [4]

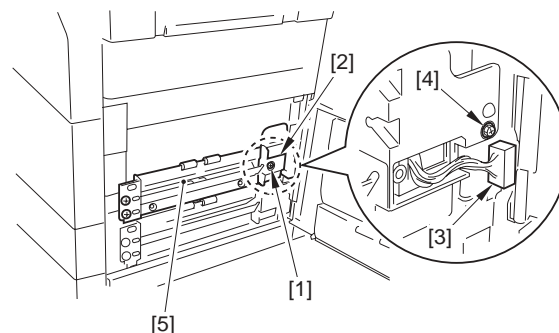

### 8.11.3 Cassette Pickup Motor

#### 8.11.3.1 Before Removing the Cassette 3/4 Pickup Motor

iR5065 / iR 5055 / iR5075 / iR5075N / iR5065N / iR5055N

- 1) Remove the charger unit (this step is necessary only for iR5075 for Japan). (page 10-22)Reference[Removing the Charger unit]
- 2) Remove the rear cover (upper). (page 10-13)Reference[Removing the Rear Cover (Upper)]
- 3) Remove the rear cover (lower). (page 10-13)Reference[Removing the Rear Cover (Lower)]
- 4) Remove the main controller box cover. (page 10-17)Reference[Removing the Main Controller Box Cover]
- 5) Remove the right cover (upper rear). (page 10-12)Reference[Removing the Right Cover (Upper Rear)]
- 6) Remove the main controller box. (page 4-13)Reference[Removing the Main Controller Box]
- 7) Remove the right cover (lower rear). (page 10-12)Reference[Removing the Right Cover (Lower Rear)]
- 8) Remove the collecting toner bottle holder. (page 5-29)Reference[Removing the Collecting Toner Bottle Holder]

#### 8.11.3.2 Removing the Cassette 3/4 Pickup Motor

iR5065 / iR 5055 / iR5075 / iR5075N / iR5065N / iR5055N

- 1) Remove the harness [1] from the 9 wire saddles.  
- 10 connectors
- 2) Remove the motor driver PCB mounting base [3].  
- 4 screws [2]

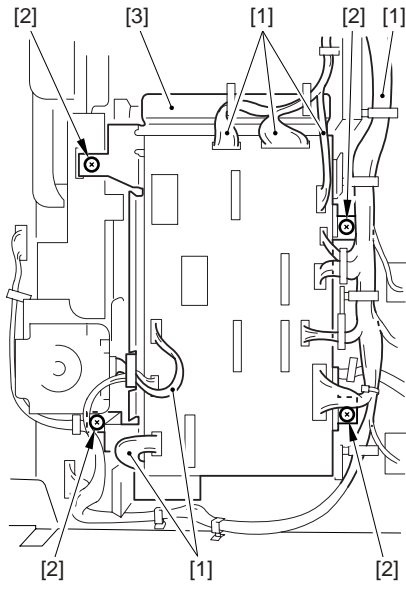

F-8-57

- 3) Remove the cassette 3/4 pickup motor [2].  
- 2 screws [1]

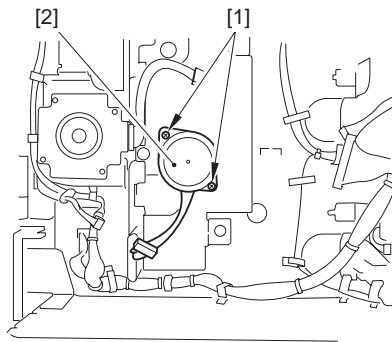

F-8-58

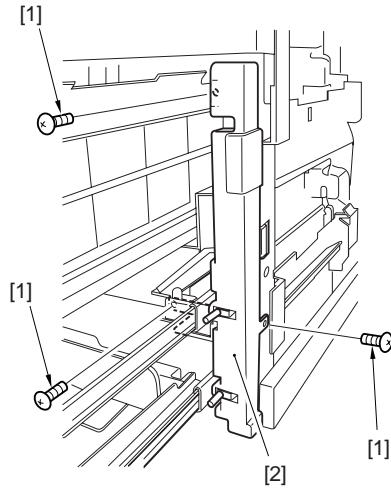

F-8-60

- 5) Remove the cassette 3 lifter motor M20 [3].  
- 2 fixing screws [1]  
- 1 connector [2]

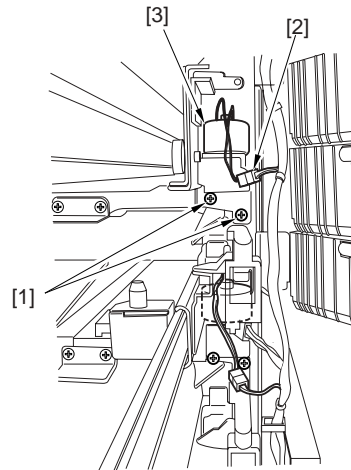

F-8-61

### 8.11.4 Cassette Lifter Motor

#### 8.11.4.1 Removing the Cassette 3 Lifter Motor M20

iR5065 / iR 5055 / iR5075 / iR5075N / iR5065N / iR5055N

- 1) Slide out the right deck and cassette 3/4.
- 2) Remove the ducker of the cassette 3 [1].

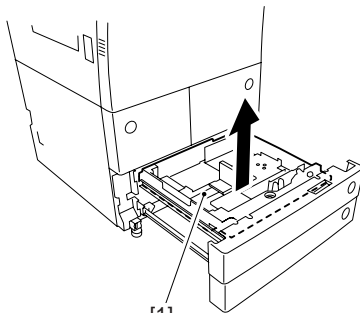

F-8-59

- 3) Open the lower right cover.
- 4) Detach the cassette right cover [2].  
- 3 screws [1]

#### 8.11.4.2 Removing the Cassette 4 Lifter Motor M21

iR5065 / iR 5055 / iR5075 / iR5075N / iR5065N / iR5055N

- 1) Slide out the right deck and the cassette 3/4.
- 2) Remove the ducker of the cassette 3 [1].

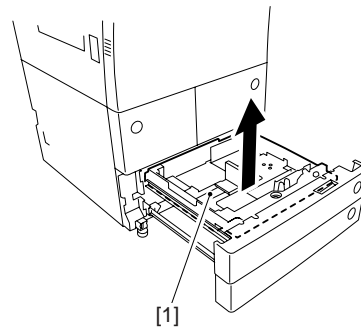

F-8-62

- 3) Open the lower right cover.
- 4) Detach the cassette right cover [2].  
- 3 screws [1]

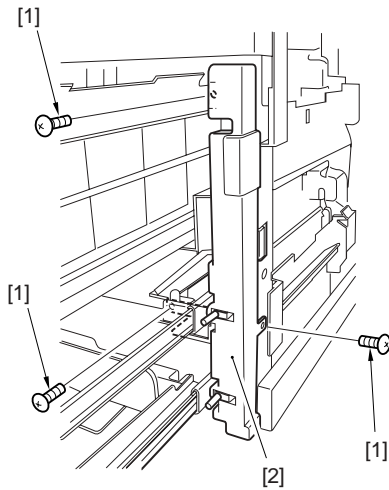

F-8-63

- 5) Remove the cassette 4 lifter motor M21 [3].  
 - 2 fixing screws [1]  
 - 1 connector [2] (Free the connector cable from the wire saddle)

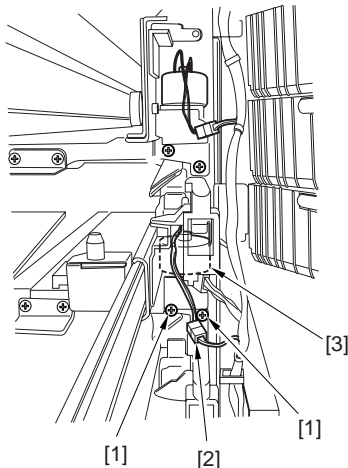

F-8-64

#### 8.11.4.3 Adjusting the Position of the Lifter Motor M20/M21 of the Cassette 3/4

iR5065 / iR 5055 / iR5075 / iR5075N / iR5065N / iR5055N

- 1) Remove the cable from the wire saddle, and detach the guide plate [3].  
 - 1 connector [1]  
 - 3 screws [2]

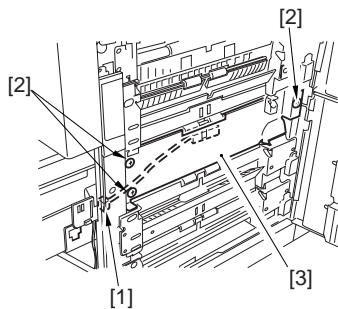

F-8-65

- 2) While keeping the lifter motor M21/M21 [1] to the right side, tighten the screw [2] temporarily.

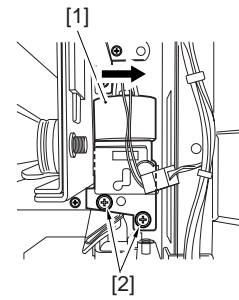

F-8-66

- 3) Set the cassette 3/4 in the machine without paper.  
 4) Check to make sure the lifer drive gear [1] is engaged with the lifter motor gear [2] from the right side of the machine.  
 5) Check to make sure the lifter drive gear is fully away from the lifter motor gear when the release button of the cassette 3/4 [3] is pressed halfway.



The condition of "pressing released button halfway" is following.  
 - Separation roller should move down.  
 - The cassette roller is about to slide out.

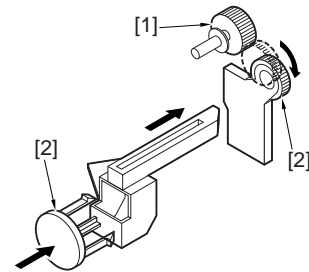

F-8-67

- 6) If the lifter drive gear is not away from the lifter motor, move the position of the lifter motor M20/M21 [1] to the left and check again with keeping the release button of the cassette 3/4 pressed halfway.

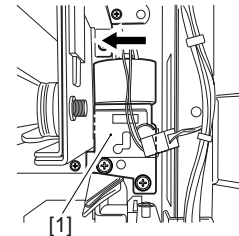

F-8-68

- 7) Fully tighten the 2 screws of the lifter motor M20/M21.  
 8) Mount back the removed parts and turn the machine on.  
 9) Check to make sure the cassette can be fully slid out when the cassette release button is pressed under the following conditions.  
 - The cassette contains no paper  
 - The cassette contains about 550 paper

#### 8.11.5 Left Deck Lifter Motor

##### 8.11.5.1 Before Removing the Left Deck Lifter Motor

iR5065 / iR 5055 / iR5075 / iR5075N / iR5065N / iR5055N

- 1) Remove the charger unit (this step is necessary only for iR5075 for Japan). (page 10-22) Reference[Removing the Charger unit]  
 2) Remove the rear cover (upper). (page 10-13) Reference[Removing the Rear Cover (Upper)]  
 3) Detach the rear cover (lower). (page 10-13) Reference[Removing the Rear Cover (Lower)]  
 4) Remove the HVT PCB. (page 10-28) Reference[Removing HVT PCB]

##### 8.11.5.2 Removing the Left Deck Lifter Motor

iR5065 / iR 5055 / iR5075 / iR5075N / iR5065N / iR5055N

- 1) Open the 2 wire saddles [1] and free the 2 harnesses [2].  
 2) Remove the left deck lifter drive assembly [5].  
 - 3 screws [3]  
 - 2 connectors [4]

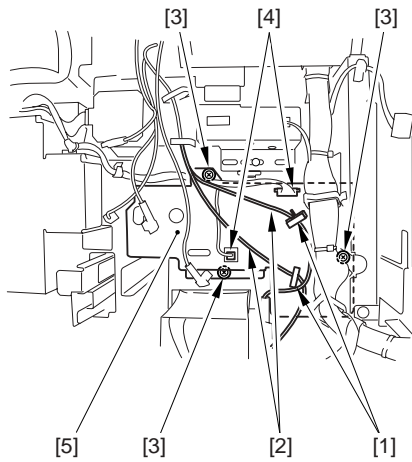

F-8-69

- 3) Remove the left deck lifter motor [2].  
- 3 screws [1]

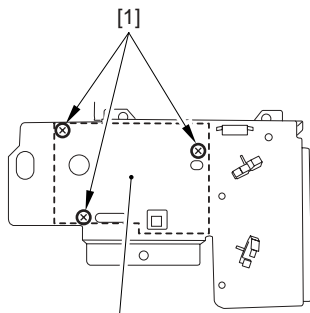

F-8-70

### 8.11.6 Right Deck Lifter Motor

#### 8.11.6.1 Before Removing the Right Deck Lifter Motor

iR5065 / iR 5055 / iR5075 / iR5075N / iR5065N / iR5055N

- 1) Remove the charger unit (this step is necessary only for iR5075 for Japan).  
(page 10-22)Reference[Removing the Charger unit]
- 2) Remove the rear cover (upper). (page 10-13)Reference[Removing the Rear Cover (Upper)]
- 3) Remove the rear cover (lower). (page 10-13)Reference[Removing the Rear Cover (Lower)]
- 4) Remove the main controller box cover. (page 10-17)Reference[Removing the Main Controller Box Cover]
- 5) Remove the right cover (upper rear). (page 10-12)Reference[Removing the Right Cover (Upper Rear)]
- 6) Remove the main controller box. (page 4-13)Reference[Removing the Main Controller Box]
- 7) Remove the right cover (lower rear). (page 10-12)Reference[Removing the Right Cover (Lower Rear)]
- 8) Remove the collecting toner bottle holder. (page 5-29)Reference[Removing the Collecting Toner Bottle Holder]

#### 8.11.6.2 Removing the Right Deck Lifter Motor

iR5065 / iR 5055 / iR5075 / iR5075N / iR5065N / iR5055N

- 1) Free the harness [1] from the 9 wire saddles.  
- 10 connectors
- 2) Remove the motor driver PCB mounting base [3].  
- 4 screws [2]

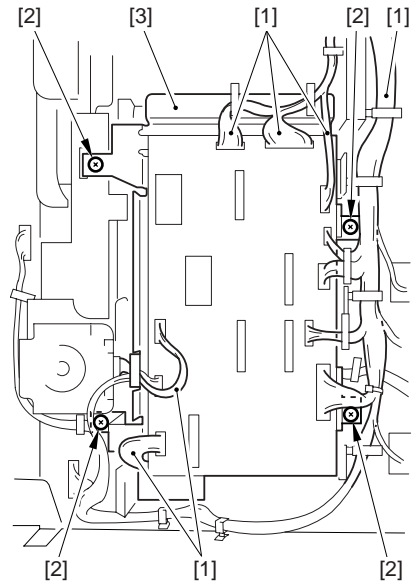

F-8-71

- 3) Free the grounding wire [2].  
- 1 screw [1]
- 4) Disconnect the 9 connectors [3].
- 5) Remove the HVT PCB [5].  
- 4 screws [4]

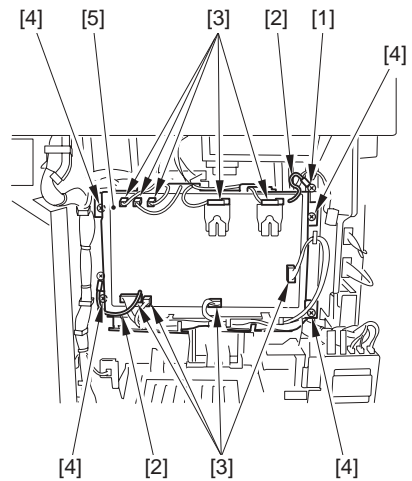

F-8-72

- 6) Remove the 3 screws [1].

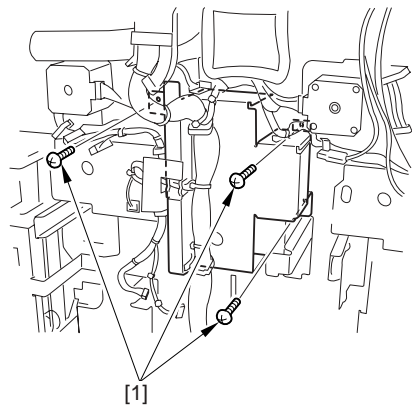

F-8-73

- 7) Remove the screw [2] while sliding the cable fixing plate [1].



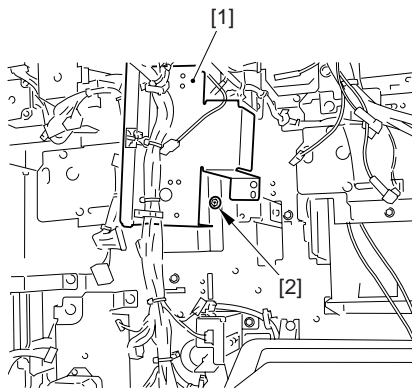

F-8-74

- 8) Remove the right deck lifter drive assembly [3].  
 - 2 connectors [1]  
 - 2 screws [2]

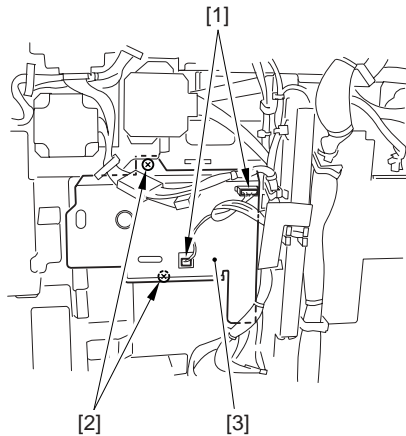

F-8-75

- 9) Remove the right deck lifter motor [2].  
 - 3 screws [1].

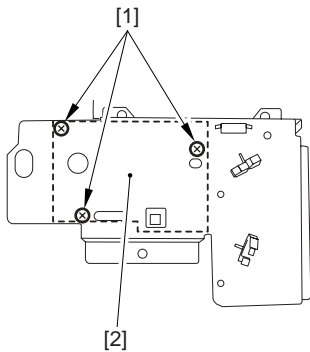

F-8-76

### 8.11.7 Right Deck Pickup Assembly

#### 8.11.7.1 Removing the Right Deck Pickup Assembly

iR5065 / iR 5055 / iR5075 / iR5075N / iR5065N / iR5055N

- 1) Slide out the right deck.
- 2) Open the right door unit (upper).

**⚠**  
 An attempt sliding out the pickup assembly without removing the deck causes the lifter get trapped and may hold the pickup assembly from sliding out.

- 3) Disconnect the connector [3].  
 - 1 screw [1]  
 - 1 connector cover [2]
- 4) Remove the right deck pickup assembly [5].  
 - 3 screws [4]

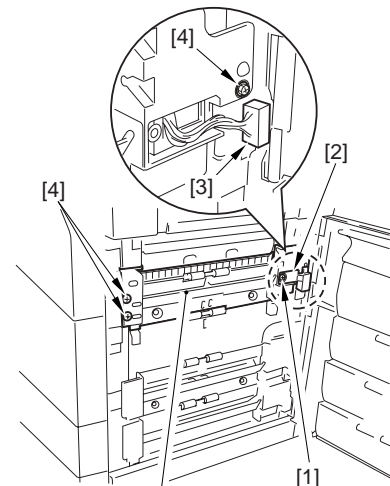

F-8-77

### 8.11.8 Left Deck Pickup Assembly

#### 8.11.8.1 Removing the Left Deck Pickup Assembly

iR5065 / iR 5055 / iR5075 / iR5075N / iR5065N / iR5055N

- 1) Slide out the left deck.
- 2) Remove the left deck [2].  
 - 2 screws [1]

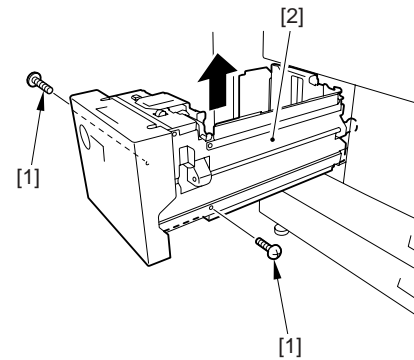

F-8-78

- 3) Open the front cover.
- 4) Disconnect the connector inside of the machine [1] and reuse band [2].

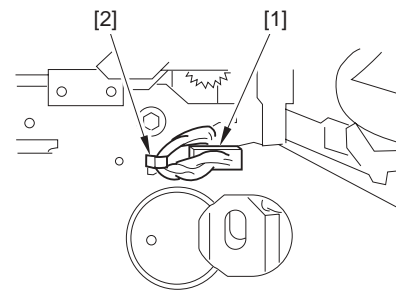

F-8-79

- 5) Remove the left deck pickup assembly [3].  
 - 2 screws [1]  
 - 2 pickup assembly fixing plate [2]

**⚠**  
 Keep supporting the pickup assembly; otherwise the pickup assembly may drop when the fixing plate is removed.

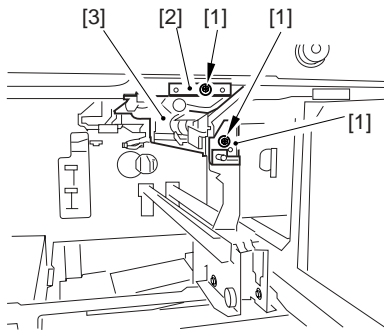

F-8-80

### 8.11.9 Left Deck Pickup Motor

#### 8.11.9.1 Before Removing the Left Deck Pickup Motor

iR5065 / iR 5055 / iR5075 / iR5075N / iR5065N / iR5055N

- 1) Remove the charger unit (this step is necessary only for iR5075 for Japan). (page 10-22)Reference[Removing the Charger unit]
- 2) Remove the rear cover (upper). (page 10-13)Reference[Removing the Rear Cover (Upper)]
- 3) Detach the rear cover (lower). (page 10-13)Reference[Removing the Rear Cover (Lower)]
- 4) Remove the HVT PCB. (page 10-28)Reference[Removing HVT PCB]

#### 8.11.9.2 Removing the Left Deck Pickup Motor

iR5065 / iR 5055 / iR5075 / iR5075N / iR5065N / iR5055N

- 1) Remove the left deck pickup motor [3].
  - 1 connector [1]
  - 2 screws [2]

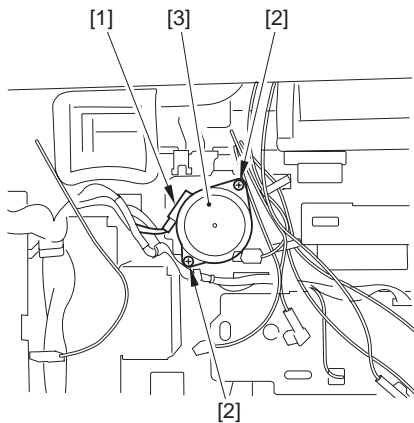

F-8-81

### 8.11.10 Right Deck Pickup Motor

#### 8.11.10.1 Before Removing the Right Deck Pickup Motor

iR5065 / iR 5055 / iR5075 / iR5075N / iR5065N / iR5055N

- 1) Remove the charger unit (this step is necessary only for iR5075 for Japan). (page 10-22)Reference[Removing the Charger unit]
- 2) Remove the rear cover (upper). (page 10-13)Reference[Removing the Rear Cover (Upper)]
- 3) Remove the rear cover (lower). (page 10-13)Reference[Removing the Rear Cover (Lower)]
- 4) Remove the main controller box cover. (page 10-17)Reference[Removing the Main Controller Box Cover]
- 5) Remove the right cover (upper rear). (page 10-12)Reference[Removing the Right Cover (Upper Rear)]
- 6) Remove the main controller box. (page 4-13)Reference[Removing the Main Controller Box]
- 7) Remove the right cover (lower rear). (page 10-12)Reference[Removing the Right Cover (Lower Rear)]
- 8) Remove the collecting toner bottle holder. (page 5-29)Reference[Removing the Collecting Toner Bottle Holder]

#### 8.11.10.2 Removing the Right Deck Pickup Motor

iR5065 / iR 5055 / iR5075 / iR5075N / iR5065N / iR5055N

- 1) Remove the right deck pickup motor [3].

- 2 screws [1]
- 1 connector [2]

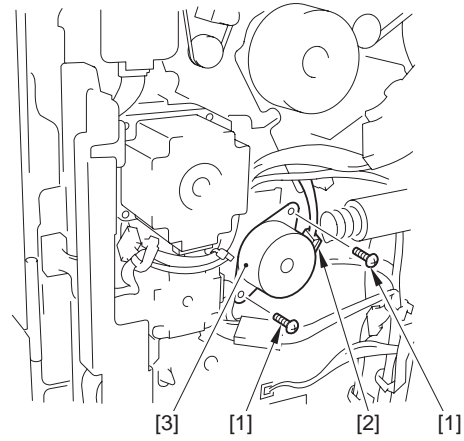

F-8-82

### 8.11.11 Left Deck Pickup Sensor

#### 8.11.11.1 Before Removing the Left Deck Feeding Sensor

iR5065 / iR 5055 / iR5075 / iR5075N / iR5065N / iR5055N

- 1) Detach the duplexing feed front cover. (page 10-14)Reference[Removing the Duplexing Feed Front Cover]
- 2) Remove the duplex feeding unit. (page 8-49)Reference[Removing the Duplex Feeding Unit]

#### 8.11.11.2 Removing the Left Deck Feeding Sensor

iR5065 / iR 5055 / iR5075 / iR5075N / iR5065N / iR5055N

- 1) Remove the connector [1] and the 2 screws [2] from the lower side of the duplex feeding unit and remove the sensor together with its mount [3].

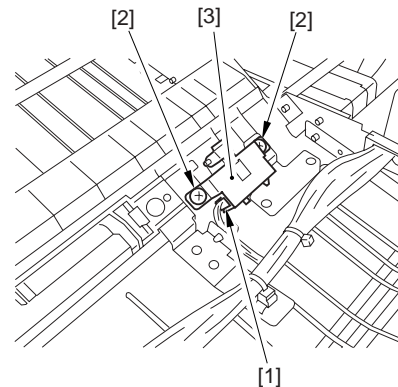

F-8-83

- 2) Remove the left deck feeding sensor [1].

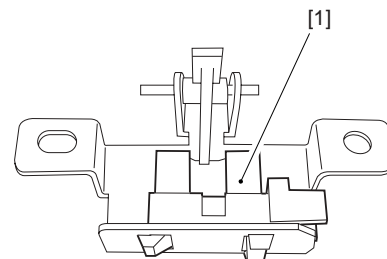

F-8-84

### 8.11.12 Left Deck Pickup Solenoid

#### 8.11.12.1 Before Removing the Left Deck Pickup Solenoid

iR5065 / iR 5055 / iR5075 / iR5075N / iR5065N / iR5055N

- 1) Remove the charger unit (this step is necessary only for iR5075 for Japan). (page 10-22)Reference[Removing the Charger unit]
- 2) Remove the rear cover (upper). (page 10-13)Reference[Removing the Rear Cover (Upper)]

- 3) Detach the rear cover (lower). (page 10-13)Reference[Removing the Rear Cover (Lower)]
- 4) Remove the HVT PCB. (page 10-28)Reference[Removing HVT PCB]

### 8.11.12.2 Removing the Left Deck Pickup Solenoid

iR5065 / iR 5055 / iR5075 / iR5075N / iR5065N / iR5055N

- 1) Mark the position [A] of the 2 mounting bases.
- 2) Remove the left deck pickup drive solenoid [3] together with the mounting base.
  - 1 connector [1]
  - 1 screw [2]

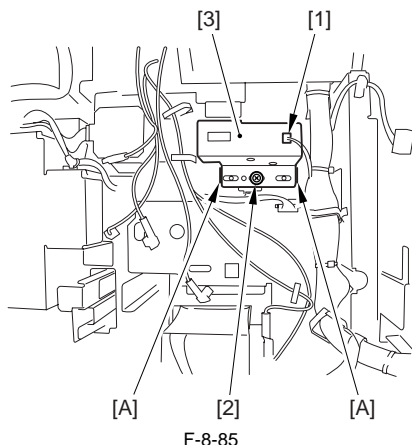

F-8-85

### 8.11.12.3 Adjusting the Position of the Left Deck Pickup Solenoid

iR5065 / iR 5055 / iR5075 / iR5075N / iR5065N / iR5055N

Before removing the left deck pickup solenoid from the support plate [1], take note of its position with reference to the fixing screw [2] of the solenoid. Or, mark the position for the solenoid by drawing a line on the support plate with a scribe.

When mounting the solenoid on its own, be sure to secure it in its original position.

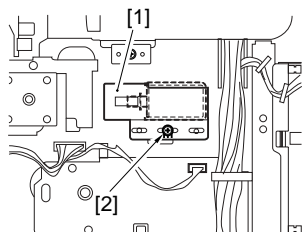

F-8-86

### 8.11.13 Manual Feed Pull-Out Roller Unit

#### 8.11.13.1 Removing the Manual Feeding Pickup Roller Unit

iR5065 / iR 5055 / iR5075 / iR5075N / iR5065N / iR5055N

- 1) Open the right door unit (upper) [1], and remove the screw [2] from the door strap and then, fully open the right door unit (upper).

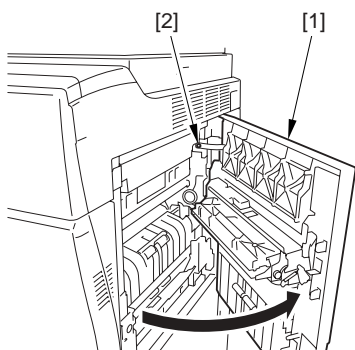

F-8-87

- 2) Slide the 2 bushings [2] and remove the manual feeding pickup roller unit [3].

- 2 resin E-rings [1]

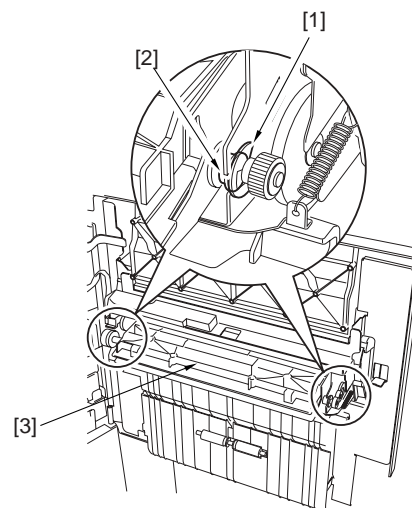

F-8-88

### 8.11.14 Manual Feed Pull-Out Roller

#### 8.11.14.1 Before Removing the Manual Feeding Pickup Roller

iR5065 / iR 5055 / iR5075 / iR5075N / iR5065N / iR5055N

- 1) Remove the manual feeding pickup roller unit. (page 8-37)Reference[Removing the Manual Feeding Pickup Roller Unit]

#### 8.11.14.2 Removing the Manual Feeding Pickup Roller

iR5065 / iR 5055 / iR5075 / iR5075N / iR5065N / iR5055N

- 1) Remove the 2 resin E-rings (right/left) [1].
- 2) Remove the stopper [2], the 2 guars [3] and the 2 bushings [4].
- 3) Remove the 2 resin E-rings [5] and the 2 bushings [6], and then remove the manual feeding pickup roller.



When removing the stopper [2] and the guar [3], be careful not to lose the three parallel pins [7]; they will slip off.

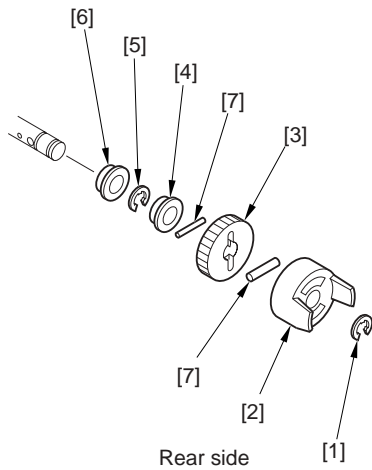

- 2 resin E-rings [1]
- 2 bushings [2]

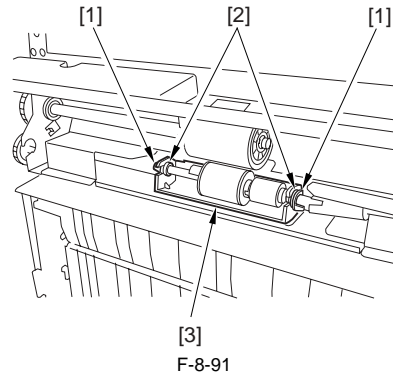

- 2) Push the hook [1] using the driver etc. in the direction of the arrow to remove the separation roller [2].

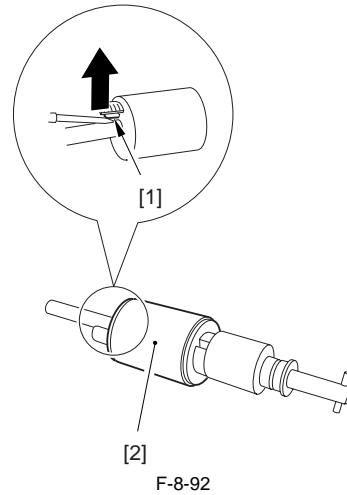
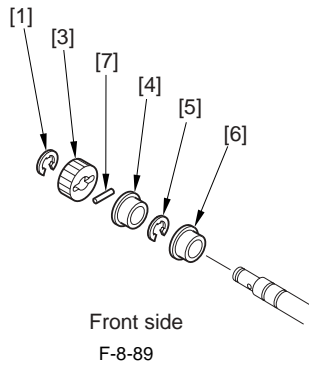

### 8.11.15 Manual Feed Roller

#### 8.11.15.1 Before Removing the Manual Feeding Roller

iR5065 / iR 5055 / iR5075 / iR5075N / iR5065N / iR5055N

- 1) Remove the manual feeding pickup roller unit. (page 8-37)Reference[Removing the Manual Feeding Pickup Roller Unit]

#### 8.11.15.2 Removing the Manual Feeding Roller

iR5065 / iR 5055 / iR5075 / iR5075N / iR5065N / iR5055N

- 1) Remove the feeding roller [2].
- 1 resin E-rings [1]

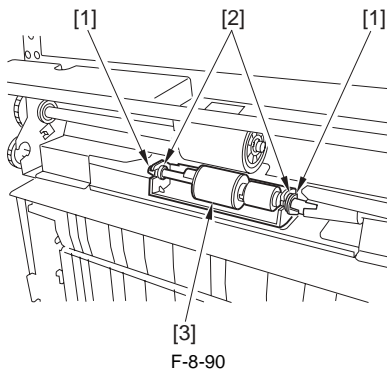

### 8.11.16 Manual Separation Roller

#### 8.11.16.1 Before Removing the Manual Separation Roller

iR5065 / iR 5055 / iR5075 / iR5075N / iR5065N / iR5055N

- 1) Remove the manual feeding pickup roller unit. (page 8-37)Reference[Removing the Manual Feeding Pickup Roller Unit]

#### 8.11.16.2 Removing the Manual Separation Roller

iR5065 / iR 5055 / iR5075 / iR5075N / iR5065N / iR5055N

- 1) Remove the separation roller assembly [3].

#### 8.11.16.3 Adjusting the Pressure of the Manual Separation Roller

iR5065 / iR 5055 / iR5075 / iR5075N / iR5065N / iR5055N

When picking up, if double feeding or failure occurs, adjust the position of the pressure spring of the separation roller.

- 1) Detach the right cover (upper).
- 2) Remove the upper guide [1].

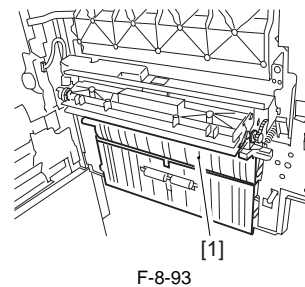

- 3) Move the mount [3] to adjust the position of the pressure spring of the separation roller.
  - If double feeding occurs, remove the mounting screw [2], lower the mounting base [3] and tighten the screw [2] in the A hole.
  - If pickup failure occurs, remove the mounting screw [2], raise the mounting base [3] and tighten the screw [2] in the B hole.

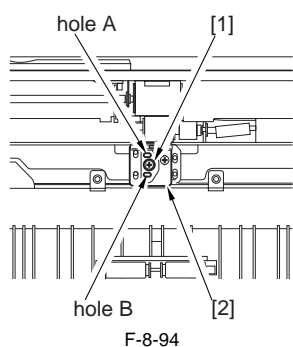

F-8-94

### 8.11.17 Manual Feed Tray paper sensor

#### 8.11.17.1 Removing the Manual Feeding Tray Sensor

iR5065 / iR 5055 / iR5075 / iR5075N / iR5065N / iR5055N

- 1) Open the right door unit (upper) [1], and remove the screw from the door strap; and then fully open the right door unit (upper).

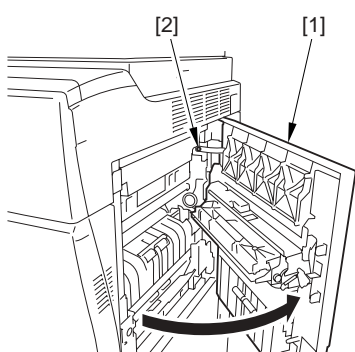

F-8-95

- 2) Detach the cover [2].  
- 1 screw [1]

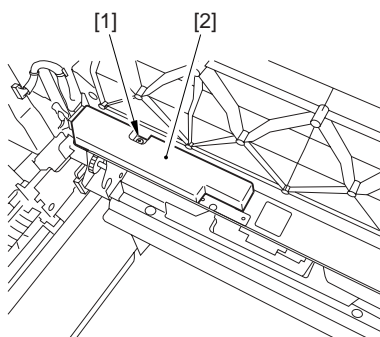

F-8-96

- 3) Remove the sensor unit [2].  
- 1 screw [1]

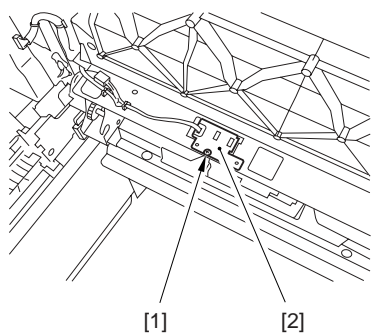

F-8-97

- 4) Free the harness [1] from the edge saddle [2], and disconnect the connector [3].
- 5) Remove the sensor [4].

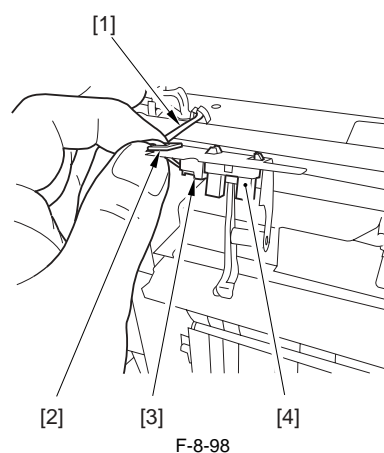

F-8-98

### 8.11.18 Registration Roller

#### 8.11.18.1 Before Removing the Registration Roller

iR5065 / iR 5055 / iR5075 / iR5075N / iR5065N / iR5055N

- 1) Detach the duplexing feed front cover. (page 10-14) Reference[Removing the Duplexing Feed Front Cover]
- 2) Remove the fixing/feeding unit. (page 9-19) Reference[Removing the Fixing/Feeding unit]
- 3) Remove the transfer/separation charging assembly. (page 7-30) Reference[Removing Transfer/Separation Charging Assembly]
- 4) Remove the registration clutch. (page 8-43) Reference[Removing the Registration Clutch]

#### 8.11.18.2 Removing the Registration Roller

iR5065 / iR 5055 / iR5075 / iR5075N / iR5065N / iR5055N

- 1) Detach the protection cover [2].  
- 1 screw [1]

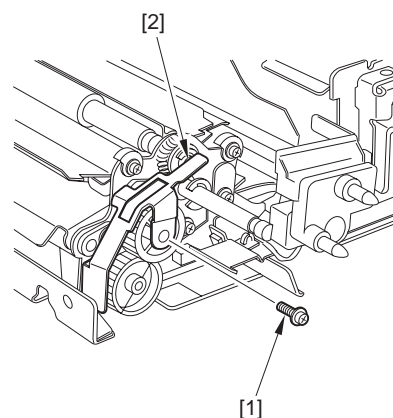

F-8-99

- 2) Remove the followings from the rear side.
  - spring [1]
  - E-ring [2]
  - spacer [3]
  - bearing [4]
  - stopper [5]

### 8.11.19.2 Removing the Registration Lower Roller

iR5065 / iR 5055 / iR5075 / iR5075N / iR5065N / iR5055N

- 1) Pull out the pre-registration guide [1] in the direction of the arrow to remove from the machine.

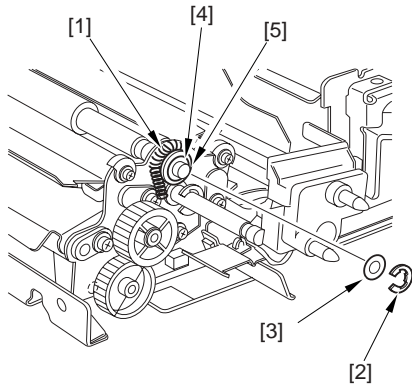

F-8-100

- 3) Remove the followings from the front side.

- Spring [1]
- E-ring [2]
- Spacer [3]
- Bearing [4]
- Stopper [5]

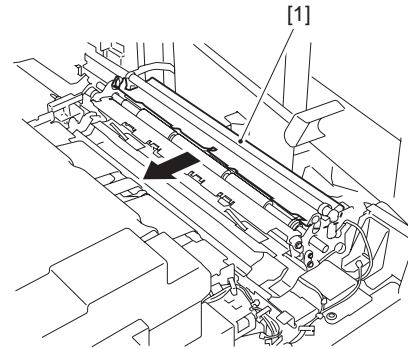

F-8-103

- 2) Remove the pre-transfer lower guide [1].

- 1 RS tightening screw [2]
- 1 holder [3]

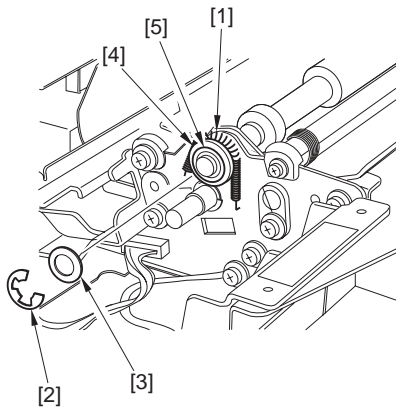

F-8-101

- 4) Pull out the registration roller [1] in the direction of the arrow in the order of [A] and [B] to remove from the machine.

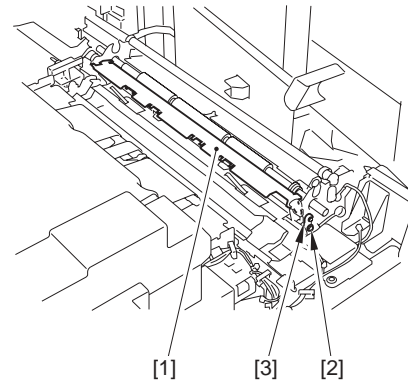

F-8-104

T-8-22

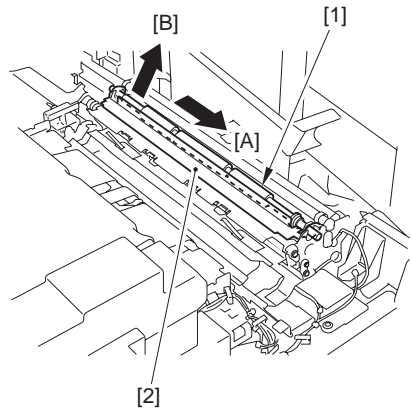

F-8-102

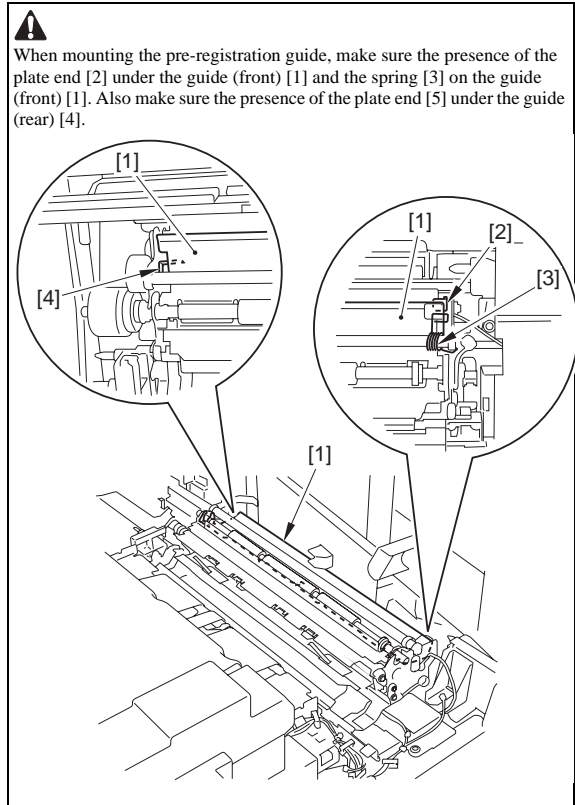

### 8.11.19 Pre-Registration Roller

#### 8.11.19.1 Before Removing the Registration Lower Roller

iR5065 / iR 5055 / iR5075 / iR5075N / iR5065N / iR5055N

- 1) Detach the duplexing feed front cover. (page 10-14) Reference [Removing the Duplexing Feed Front Cover]
- 2) Remove the fixing/feeding unit. (page 9-19) Reference [Removing the Fixing/Feeding unit]
- 3) Remove the transfer/separation charging assembly. (page 7-30) Reference [Removing Transfer/Separation Charging Assembly]
- 4) Remove the registration clutch. (page 8-43) Reference [Removing the Registration Clutch]
- 5) Remove the registration brake. (page 8-43) Reference [Removing the Registration Brake]

- 3) Remove the registration lower roller [1].

- 1 spacer [2]
- 3 E-rings [3]

- 2 washers [4]
- 2 bearings [5]

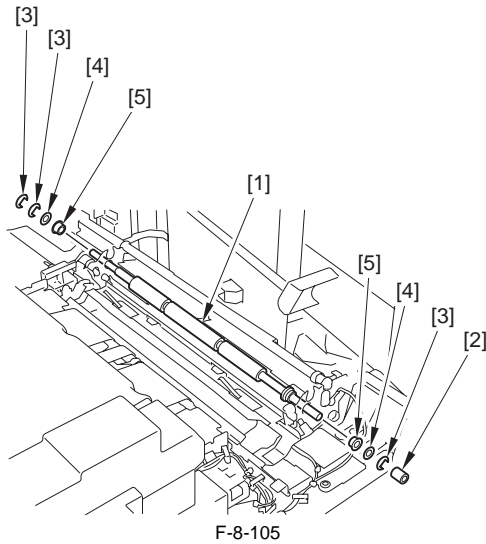

F-8-105

### 8.11.20 Pre-Registration Motor

#### 8.11.20.1 Before Removing the Registration Front Motor

iR5065 / iR 5055 / iR5075 / iR5075N / iR5065N / iR5055N

- 1) Detach the rear cover (upper). (page 10-13)Reference[Removing the Rear Cover (Upper)]
- 2) Detach the main controller box cover. (page 10-17)Reference[Removing the Main Controller Box Cover]
- 3) Detach the right cover (upper rear). (page 10-12)Reference[Removing the Right Cover (Upper Rear)]
- 4) Remove the main controller box. (page 4-13)Reference[Removing the Main Controller Box]

#### 8.11.20.2 Removing the Registration Front Motor

iR5065 / iR 5055 / iR5075 / iR5075N / iR5065N / iR5055N

- 1) Remove the registration front motor [3].
  - 1 connector [1]
  - 3 screws [2]

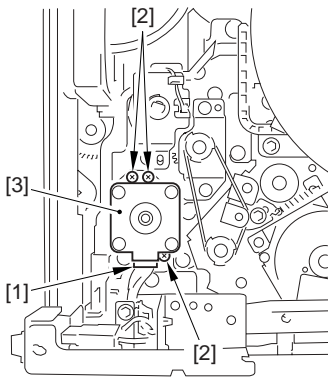

F-8-106

### 8.11.21 Registration Motor

#### 8.11.21.1 Before Removing the Horizontal Registration Motor

iR5065 / iR 5055 / iR5075 / iR5075N / iR5065N / iR5055N

- 1) Detach the duplexing feed front cover. (page 10-14)Reference[Removing the Duplexing Feed Front Cover]
- 2) Remove the duplex feeding unit. (page 8-49)Reference[Removing the Duplex Feeding Unit]

#### 8.11.21.2 Removing the Horizontal Registration Motor

iR5065 / iR 5055 / iR5075 / iR5075N / iR5065N / iR5055N

- 1) Remove the fan together with the mount. [3]
  - 2 screws [1]
  - 1 connector [2]

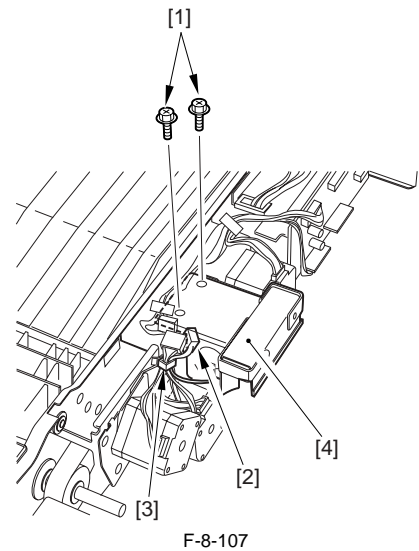

F-8-107

- 2) Free the harness from the 3 wire saddles [1].

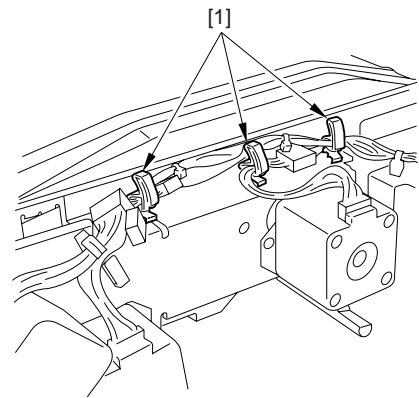

F-8-108

- 3) Remove the 2 screws [1].

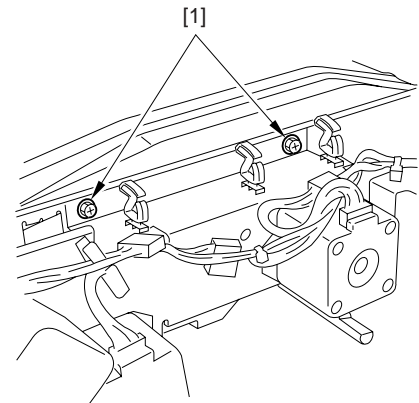

F-8-109

- 4) Turn the duplex feeding unit over.
- 5) Slide the unit.
  - 4 screws [1]

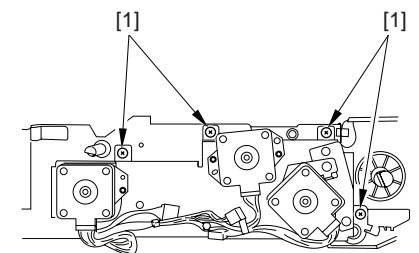

F-8-110

- 6) Disconnect the connector of the duplex feeding unit in the rear side [1], and free the harness [2] from the 2 edge saddles [3].

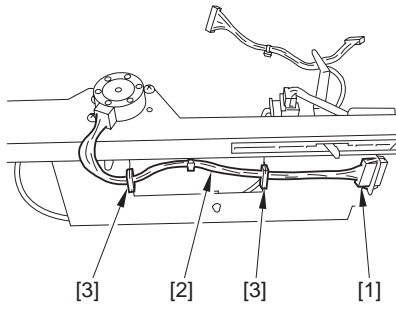

F-8-111

- 7) Slide the horizontal registration unit [2].  
- 2 screws [1]

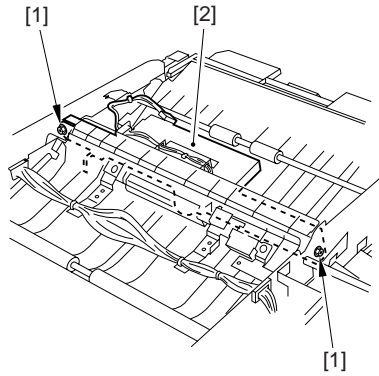

F-8-112

- 8) Remove the horizontal registration motor [2].  
- 2 screws [1]

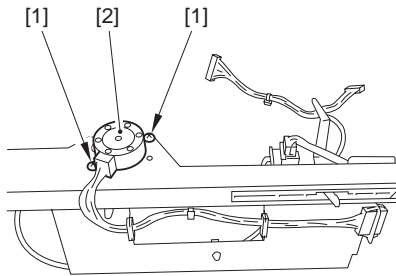

F-8-113

### 8.11.22 Registration Sensor

#### 8.11.22.1 Before Removing the Horizontal Registration Sensor

iR5065 / iR 5055 / iR5075 / iR5075N / iR5065N / iR5055N

- 1) Detach the duplexing feed front cover. (page 10-14) Reference [Removing the Duplexing Feed Front Cover]
- 2) Remove the duplex feeding unit. (page 8-49) Reference [Removing the Duplex Feeding Unit]

#### 8.11.22.2 Removing the Horizontal Registration Sensor

iR5065 / iR 5055 / iR5075 / iR5075N / iR5065N / iR5055N

- 1) Remove the fan together with the mount [3].  
- 2 screws [1]  
- 1 connector [2]

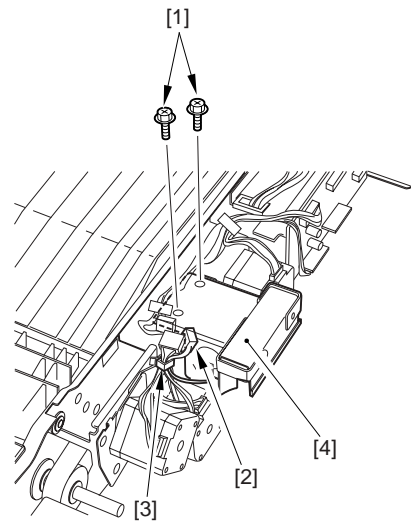

F-8-114

- 2) Free the harness from the 3 wire saddles [1].

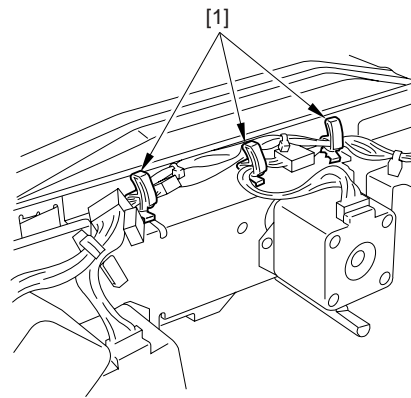

F-8-115

- 3) Remove the 2 screws [1].

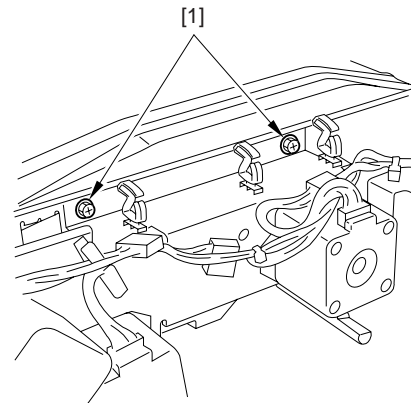

F-8-116

- 4) Turn the duplex feeding unit over.
- 5) Slide the unit.  
- 4 screws [1]

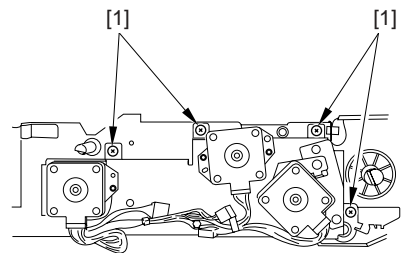

F-8-117

- 6) Disconnect the connector of the duplex feeding unit in the rear side [1], and free the harness [2] from the 2 edge saddles [3].



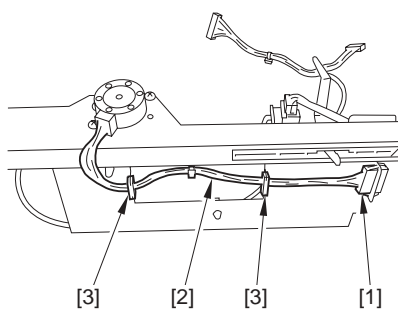

F-8-118

- 7) Slide the horizontal registration unit [2].  
- 2 screws [1]

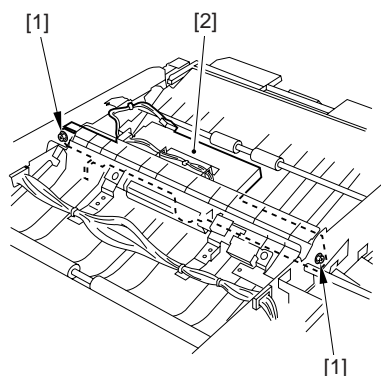

F-8-119

- 8) Remove the horizontal registration motor [2].  
- 2 screws [1]

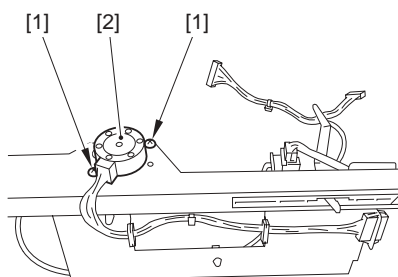

F-8-120

- 9) Remove the horizontal registration sensor [2].  
- 1 connector [1]

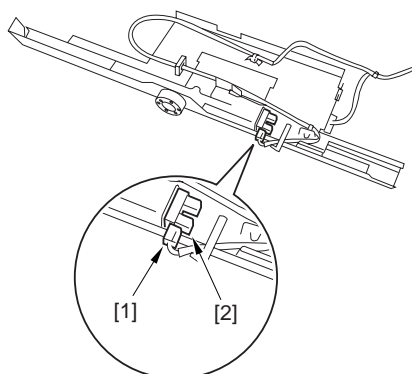

F-8-121

## 8.11.23 Registration Clutch

### 8.11.23.1 Before Removing the Registration Clutch

iR5065 / iR 5055 / iR5075 / iR5075N / iR5065N / iR5055N

- 1) Detach the duplexing feed front cover. (page 10-14) Reference[Removing the Duplexing Feed Front Cover]
- 2) Remove the duplex feeding unit. (page 8-49) Reference[Removing the Duplex Feeding Unit]

### 8.11.23.2 Removing the Registration Clutch

iR5065 / iR 5055 / iR5075 / iR5075N / iR5065N / iR5055N

- 1) Remove the registration clutch [3].  
- 1 connector [1]  
- 1 E-ring [2]

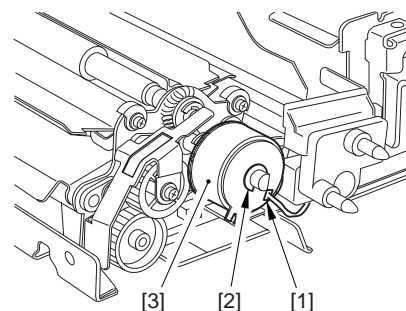

F-8-122

## 8.11.24 Registration Brake Clutch

### 8.11.24.1 Before Removing the Registration Brake

iR5065 / iR 5055 / iR5075 / iR5075N / iR5065N / iR5055N

- 1) Detach the duplexing feed front cover. (page 10-14) Reference[Removing the Duplexing Feed Front Cover]
- 2) Remove the fixing/feeding unit. (page 9-19) Reference[Removing the Fixing/Feeding unit]
- 3) Remove the transfer/separation charging assembly. (page 7-30) Reference[Removing Transfer/Separation Charging Assembly]
- 4) Remove the registration clutch. (page 8-43) Reference[Removing the Registration Clutch]

### 8.11.24.2 Removing the Registration Brake

iR5065 / iR 5055 / iR5075 / iR5075N / iR5065N / iR5055N

- 1) Remove the registration brake [1].  
- 1 screw [2]

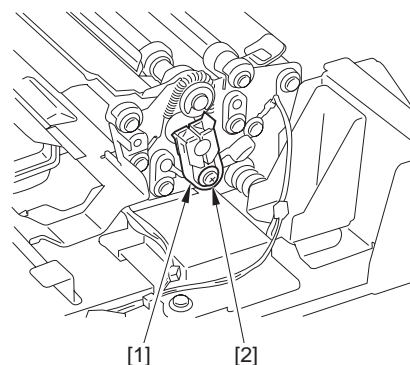

F-8-123

## 8.11.25 Feeding Roller

### 8.11.25.1 Before Removing the Feeding Roller

iR5065 / iR 5055 / iR5075 / iR5075N / iR5065N / iR5055N

- 1) Remove the right deck pickup assembly. (page 8-35) Reference[Removing the Right Deck Pickup Assembly]
- 2) Remove the cassette pickup assembly. (page 8-31) Reference[Removing the Cassette 3/4 Pickup Assembly]
- 3) Remove the left deck pickup assembly. (page 8-35) Reference[Removing the Left Deck Pickup Assembly]

### 8.11.25.2 Removing the Feeding Roller

iR5065 / iR 5055 / iR5075 / iR5075N / iR5065N / iR5055N

- 1) Detach the feeding roller cover [1].  
- 1 screw [2]  
(Skip this step in for the left deck pickup assembly)
- 2) Remove the resin E-ring [3] in the front side of the feeding roller.
- 3) Remove the feeding roller [5] together with the timing belt [4].

Cassette 3/4, Right deck pickup assembly

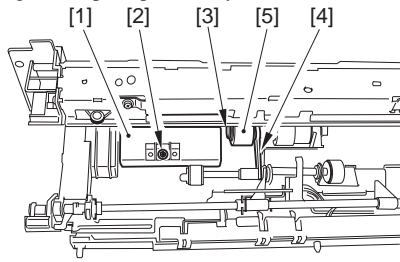

F-8-124

Left deck pickup assembly

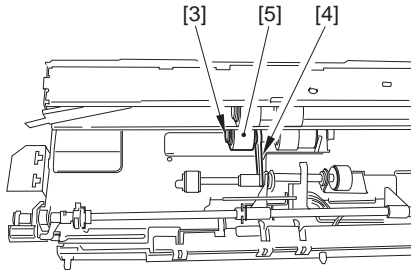

F-8-125

8.11.25.3 The Points to Mount the Feeding Roller

iR5065 / iR 5055 / iR5075 / iR5075N / iR5065N / iR5055N

When mounting the feeding roller [1] to the cassette pickup assembly, make sure the belt pulley [2] is at the front of the machine.



Check to make sure the protrusion in the roller plate and roller are engaged securely.

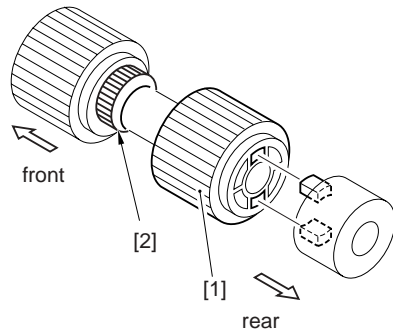

F-8-126

8.11.26 Vertical Path Roller

8.11.26.1 Before Removing the Vertical Path Roller

iR5065 / iR 5055 / iR5075 / iR5075N / iR5065N / iR5055N

- 1) Remove the right deck pickup assembly. (page 8-35) Reference[Removing the Right Deck Pickup Assembly]
- 2) Remove the cassette pickup assembly. (page 8-31) Reference[Removing the Cassette 3/4 Pickup Assembly]

8.11.26.2 Removing the Vertical Path Roller

iR5065 / iR 5055 / iR5075 / iR5075N / iR5065N / iR5055N

- 1) Remove the followings from the front side of the right deck pickup assembly.
  - 1 E-ring [1]
  - 1 bearing [2]
- 2) Remove the followings from the rear side of the right deck pickup assembly.
  - 1 E-ring [3]
  - 2 bushings [4]
  - 1 roller base [5]
  - 1 blue guar [6]
  - 1 parallel screw [7]

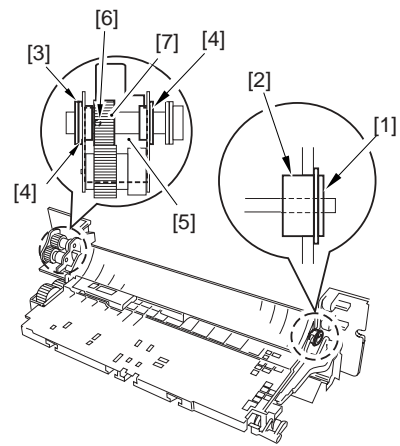

F-8-127

- 3) Remove the vertical path roller 1 [2]
- 1 guide plate [1]

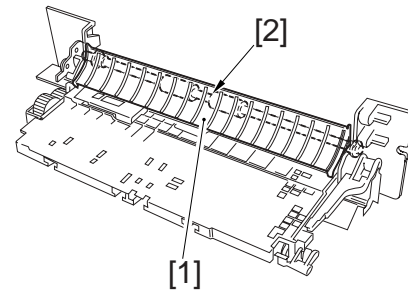

F-8-128

8.11.26.3 Removing the Vertical Path Roller 2/3

iR5065 / iR 5055 / iR5075 / iR5075N / iR5065N / iR5055N

- 1) Remove the followings from the front side of the cassette 3/4 pickup assembly.
  - 1 E-ring [1]
  - 1 spacer [2]
  - 1 bearing [3]
- 2) Remove the followings from the rear side of the cassette 3/4 pickup assembly.
  - 1 E-ring [4]
  - 2 bushings [5]
  - 1 roller base [6]
  - 1 blue guar [7]
  - 1 parallel screw [8]
- 3) Remove the vertical path roller 2/3 [9].

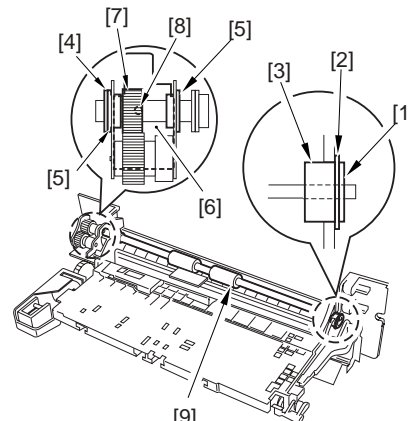

F-8-129

8.11.27 Vertical Path Motor

8.11.27.1 Before Removing the Vertical Path Upper Motor

iR5065 / iR 5055 / iR5075 / iR5075N / iR5065N / iR5055N

- 1) Remove the charger unit (this step is necessary only for iR5075 for Japan). (page 10-22) Reference[Removing the Charger unit]
- 2) Remove the rear cover (upper). (page 10-13) Reference[Removing the

- Rear Cover (Upper)]
- 3) Detach the rear cover (lower). (page 10-13)Reference[Removing the Rear Cover (Lower)]
  - 4) Detach the right cover (upper rear). (page 10-12)Reference[Removing the Right Cover (Upper Rear)]
  - 5) Detach the right cover (lower rear). (page 10-12)Reference[Removing the Right Cover (Lower Rear)]
  - 6) Detach the main controller box cover. (page 10-17)Reference[Removing the Main Controller Box Cover]
  - 7) Remove the main controller box. (page 4-13)Reference[Removing the Main Controller Box]
  - 8) Remove the collecting toner bottle holder. (page 5-29)Reference[Removing the Collecting Toner Bottle Holder]

### 8.11.27.2 Removing the Vertical Path Upper Motor

iR5065 / iR 5055 / iR5075 / iR5075N / iR5065N / iR5055N

- 1) Remove the vertical path upper motor [3].
  - 2 screws [1]
  - 1 connector [2]

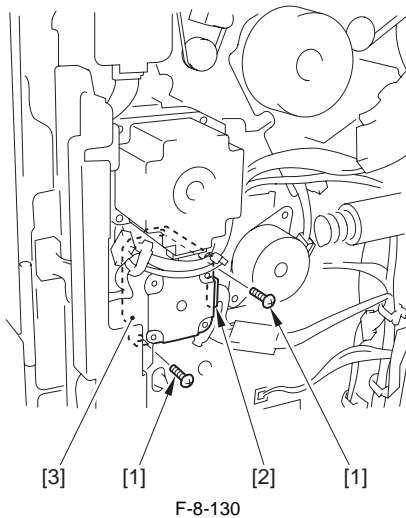

### 8.11.28 Vertical Path Duplex Motor

#### 8.11.28.1 Before Removing the Vertical Path Duplex Motor

iR5065 / iR 5055 / iR5075 / iR5075N / iR5065N / iR5055N

- 1) Remove the charger unit (this step is necessary only for iR5075 for Japan). (page 10-22)Reference[Removing the Charger unit]
- 2) Remove the rear cover (upper). (page 10-13)Reference[Removing the Rear Cover (Upper)]
- 3) Detach the rear cover (lower). (page 10-13)Reference[Removing the Rear Cover (Lower)]
- 4) Detach the right cover (upper rear). (page 10-12)Reference[Removing the Right Cover (Upper Rear)]
- 5) Detach the right cover (lower rear). (page 10-12)Reference[Removing the Right Cover (Lower Rear)]
- 6) Detach the main controller box cover. (page 10-17)Reference[Removing the Main Controller Box Cover]
- 7) Remove the main controller box. (page 4-13)Reference[Removing the Main Controller Box]
- 8) Remove the collecting toner bottle holder. (page 5-29)Reference[Removing the Collecting Toner Bottle Holder]

#### 8.11.28.2 Removing the Vertical Path Duplex Motor

iR5065 / iR 5055 / iR5075 / iR5075N / iR5065N / iR5055N

- 1) Remove the vertical path duplex motor [3].
  - 3 screws [1]
  - 2 connectors [2]

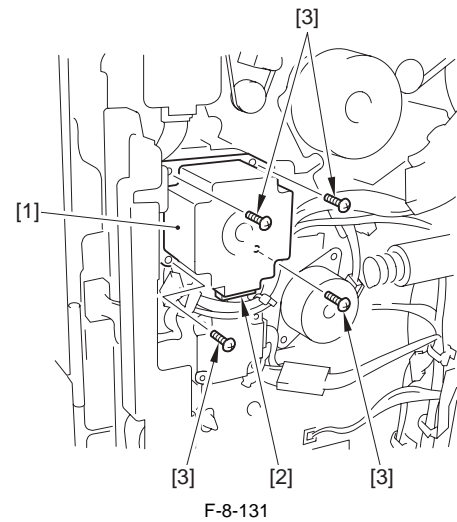

### 8.11.29 Vertical Path Lower Motor

#### 8.11.29.1 Before Removing the Vertical Path Lower Motor

iR5065 / iR 5055 / iR5075 / iR5075N / iR5065N / iR5055N

- 1) Remove the charger unit (this step is necessary only for iR5075 for Japan). (page 10-22)Reference[Removing the Charger unit]
- 2) Remove the rear cover (upper). (page 10-13)Reference[Removing the Rear Cover (Upper)]
- 3) Detach the rear cover (lower). (page 10-13)Reference[Removing the Rear Cover (Lower)]
- 4) Detach the right cover (upper rear). (page 10-12)Reference[Removing the Right Cover (Upper Rear)]
- 5) Detach the right cover (lower rear). (page 10-12)Reference[Removing the Right Cover (Lower Rear)]
- 6) Detach the main controller box cover. (page 10-17)Reference[Removing the Main Controller Box Cover]
- 7) Remove the main controller box. (page 4-13)Reference[Removing the Main Controller Box]
- 8) Remove the collecting toner bottle holder. (page 5-29)Reference[Removing the Collecting Toner Bottle Holder]

#### 8.11.29.2 Removing the Vertical Path Lower Motor

iR5065 / iR 5055 / iR5075 / iR5075N / iR5065N / iR5055N

- 1) Remove the vertical path lower motor [3].
  - 3 screws [1]
  - 1 connector [2]

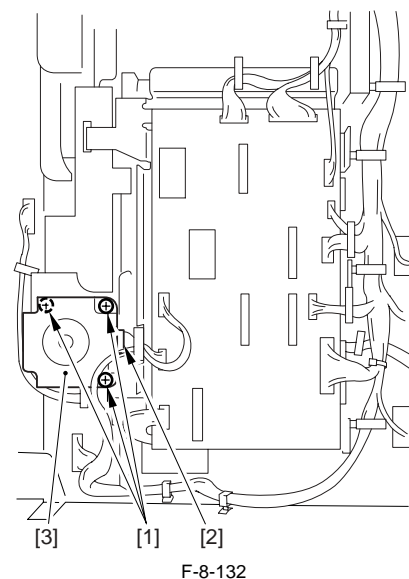

### 8.11.30 Reversing Motor

#### 8.11.30.1 Before Removing the Reversing Motor

iR5065 / iR 5055 / iR5075 / iR5075N / iR5065N / iR5055N

- 1) Detach the duplexing feed front cover. (page 10-14) Reference [Removing the Duplexing Feed Front Cover]
- 2) Remove the duplex feeding unit. (page 8-49) Reference [Removing the Duplex Feeding Unit]

### 8.11.30.2 Removing the Reversing Motor

iR5065 / iR 5055 / iR5075 / iR5075N / iR5065N / iR5055N

- 1) Disconnect the connector [1].
- 2) Remove the reversing motor [3] together with the support plate.
  - 3 screws [2]

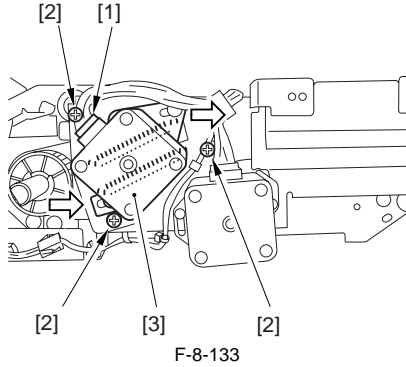

- 3) Remove the reversing motor [2] from the support plate.
  - 2 screws [1]

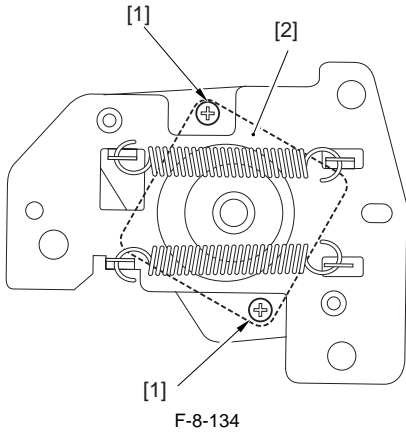

### 8.11.30.3 Mounting the Reversing Motor

iR5065 / iR 5055 / iR5075 / iR5075N / iR5065N / iR5055N

- 1) Mount the 2 support plates [2] and the reversing motor [3] using 3 screws [1], and then attach the timing belt [4].

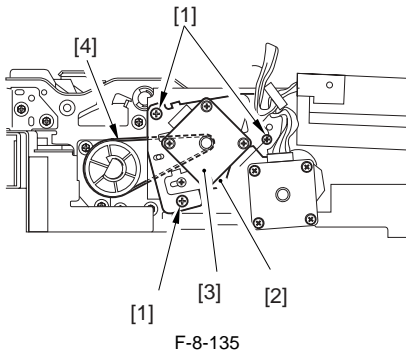

At the end, make sure the timing belt has tension.

### 8.11.31 Fixing Feeding Unit Releasing Lever Sensor

#### 8.11.31.1 Before Removing the Fixing Feeding Unit Release Lever Sensor

iR5065 / iR 5055 / iR5075 / iR5075N / iR5065N / iR5055N

- 1) Detach the fixing front cover. (page 10-16) Reference [Removing the Fixing Front Cover]
- 2) Detach the fixing/feeding unit front cover. (page 10-15) Reference [Removing the Fixing/Feeding Unit Front Cover]
- 3) Detach the fixing/feeding unit middle cover. (page 10-15) Reference [Removing the Fixing/Feeding Unit Middle Cover]

#### 8.11.31.2 Removing the Fixing Feeding Unit Release Lever Sensor

iR5065 / iR 5055 / iR5075 / iR5075N / iR5065N / iR5055N

- 1) Free the harness from the wire saddle [3], and slide from the harness guide [4].
  - 1 connector [1]
  - 1 screw [2]

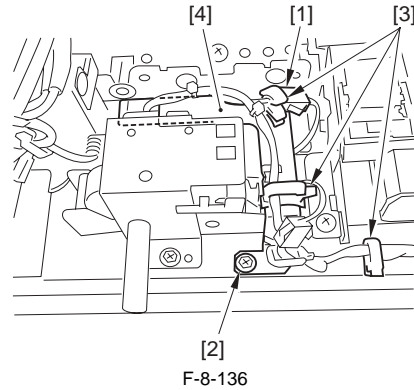

- 2) Detach the fixing feeding unit release lever support plate [2].
  - 2 screws [1]

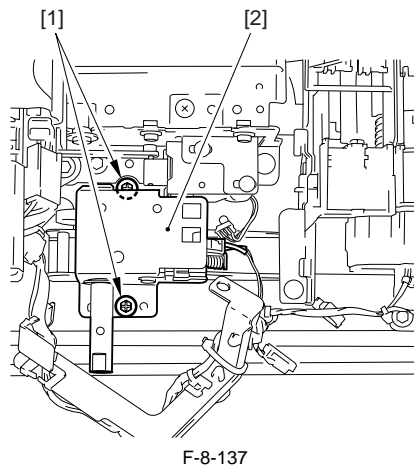

- 3) Remove the release lever switch [2].
  - 1 screw [1]

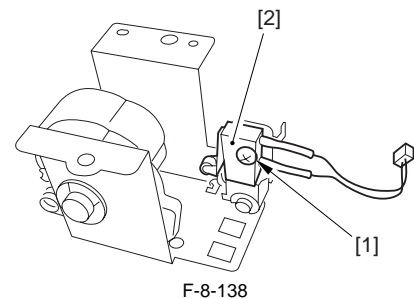

### 8.11.32 Reversing Sensor

#### 8.11.32.1 Before Removing the Reversing Sensor 1

iR5065 / iR 5055 / iR5075 / iR5075N / iR5065N / iR5055N

- 1) Detach the duplexing feed front cover. (page 10-14) Reference [Removing the Duplexing Feed Front Cover]
- 2) Remove the duplex feeding unit. (page 8-49) Reference [Removing the Duplex Feeding Unit]

### 8.11.32.2 Removing the Reversing Sensor 1

iR5065 / iR 5055 / iR5075 / iR5075N / iR5065N / iR5055N

- 1) Remove the Sensor together with the mount [3].
  - 2 screws [1]
  - 1 grounding wire [2]

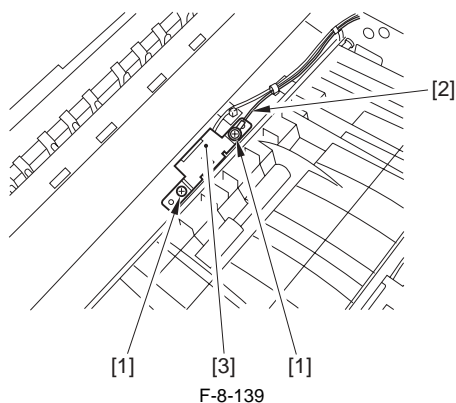

- 2) Remove the sensor [2].
  - 1 connector [1]

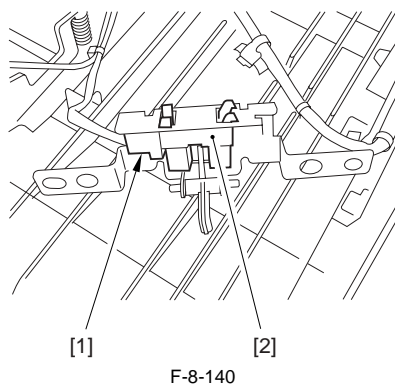

### 8.11.32.3 Before Removing the Reversing Sensor 2

iR5065 / iR 5055 / iR5075 / iR5075N / iR5065N / iR5055N

- 1) Detach the duplexing feed front cover. (page 10-14) Reference [Removing the Duplexing Feed Front Cover]
- 2) Remove the duplex feeding unit. (page 8-49) Reference [Removing the Duplex Feeding Unit]

### 8.11.32.4 Removing the Reversing Sensor 2

iR5065 / iR 5055 / iR5075 / iR5075N / iR5065N / iR5055N

- 1) Remove the sensor together with the mount [3].
  - 2 screws [1]
  - 1 grounding wire [2]

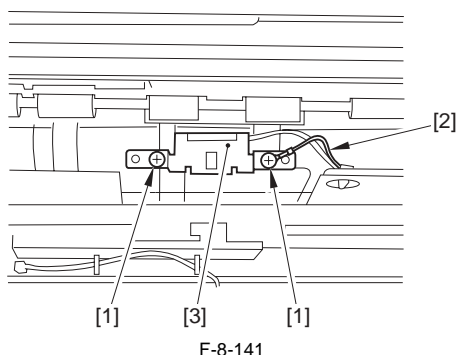

- 2) Remove the sensor [2].
  - 1 connector [1]

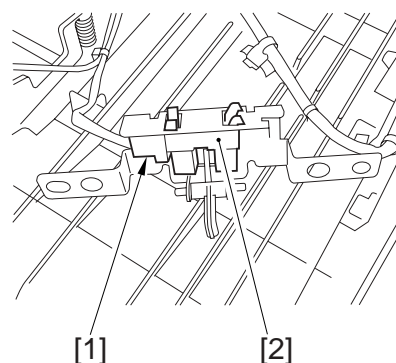

### 8.11.33 Reversing Unit

#### 8.11.33.1 Before Removing the Reversing Flapper Solenoid

iR5065 / iR 5055 / iR5075 / iR5075N / iR5065N / iR5055N

- 1) Detach the duplexing feed front cover. (page 10-14) Reference [Removing the Duplexing Feed Front Cover]
- 2) Remove the duplex feeding unit. (page 8-49) Reference [Removing the Duplex Feeding Unit]

#### 8.11.33.2 Removing the Reversing Flapper Solenoid

iR5065 / iR 5055 / iR5075 / iR5075N / iR5065N / iR5055N

- 1) Free the harness [3] from the guide [2].
  - 1 connector [1]
- 2) Remove the reversing flapper solenoid [6].
  - 2 screws [4]
  - 1 grounding wire [5]

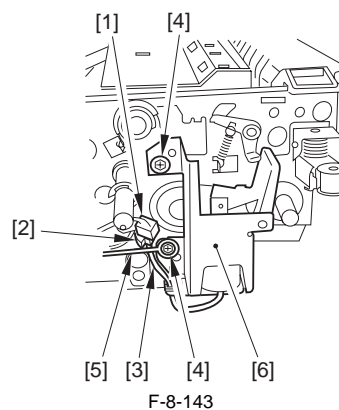

#### 8.11.33.3 Mounting the Reversing Flapper Solenoid

iR5065 / iR 5055 / iR5075 / iR5075N / iR5065N / iR5055N



Before removing the screw, make sure to mark the line in the following step.

- 1) Adjust the position of the solenoid using the 2 screws [1] so that the driver lever [2] is pushed fully when the solenoid is on (i.e., when the plunger is down)

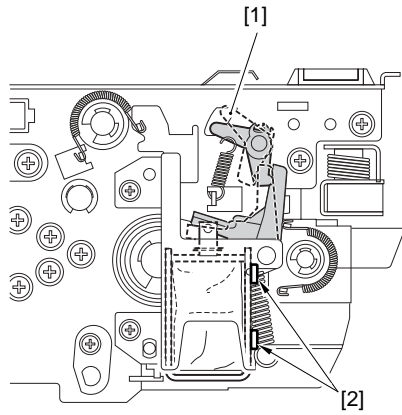

F-8-144

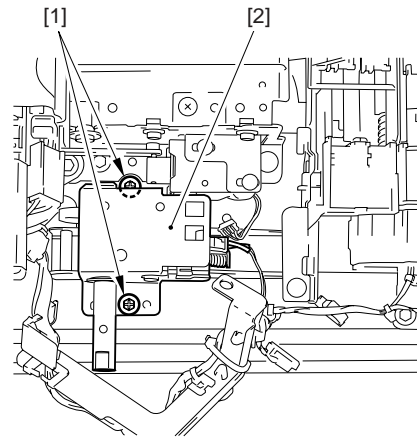

F-8-146

### 8.11.34 Feeding Belt

#### 8.11.34.1 Before Removing the feeding belt

iR5065 / iR 5055 / iR5075 / iR5075N / iR5065N / iR5055N

- 1) Detach the duplexing feed front cover. (page 10-14) Reference[Removing the Duplexing Feed Front Cover]
- 2) Remove the duplex feeding unit. (page 8-49) Reference[Removing the Duplex Feeding Unit]
- 3) Detach the fixing front cover. (page 10-16) Reference[Removing the Fixing Front Cover]
- 4) Detach the fixing upper cover. (page 10-15) Reference[Removing the Fixing Upper Cover]
- 5) Detach the fixing/feeding unit front cover. (page 10-15) Reference[Removing the Fixing/Feeding Unit Front Cover]
- 6) Detach the fixing/feeding unit middle cover. (page 10-15) Reference[Removing the Fixing/Feeding Unit Middle Cover]
- 7) Remove the fixing drive assembly. (page 10-22) Reference[Removing the Fixing Drive Assembly]

- 3) Remove the 2 screws [3].
  - 1 E-ring [1]
  - 1 bearing [2]

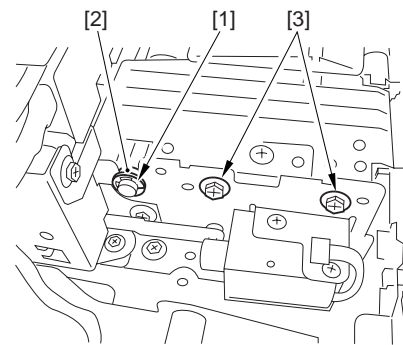

F-8-147

#### 8.11.34.2 Removing the feeding belt

iR5065 / iR 5055 / iR5075 / iR5075N / iR5065N / iR5055N

- 1) Free the harness from the wire saddle [3], and slide the harness guide [4].
  - 1 connector [1]
  - 1 screw [2]

- 4) Remove the feeding belt unit [7].
  - 1 E-ring [1]
  - 1 pulley [2]
  - 1 pin [3]
  - 1 screw [4]
  - 1 E-ring [5]
  - 1 bearing [6]

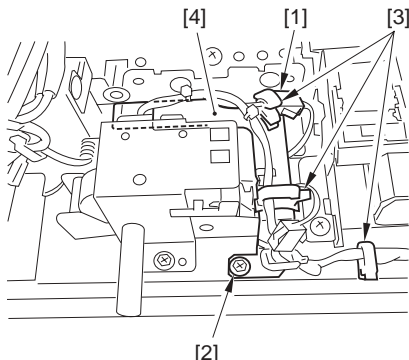

F-8-145

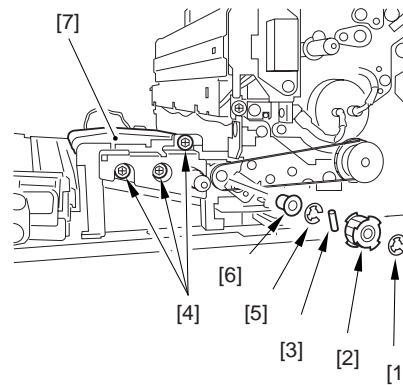

F-8-148

- 2) Detach the fixing feeding unit release lever support plate [2].
  - 2 screws [1]

- 5) Detach the cover [2].
  - 1 screw [1]
- 6) Remove the feeding belt [3] and the postcard belt [4].

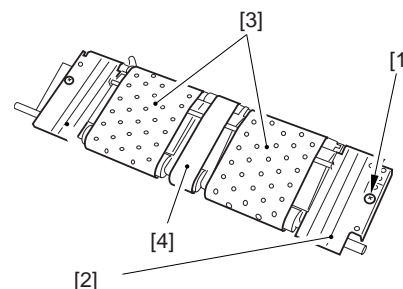

F-8-149

## 8.11.35 Duplexing Unit

### 8.11.35.1 Before Removing the Duplex Feeding Unit

iR5065 / iR 5055 / iR5075 / iR5075N / iR5065N / iR5055N

- 1) Detach the duplexing feed front cover. (page 10-14) Reference [Removing the Duplexing Feed Front Cover]

### 8.11.35.2 Removing the Duplex Feeding Unit

iR5065 / iR 5055 / iR5075 / iR5075N / iR5065N / iR5055N

- 1) Remove the duplex feeding unit with holding its grip [1] (right/left) from the machine.



Be careful not to trap your hand between the grip and the rail. Further, do not place the duplex unit where the parts might suffer damage.

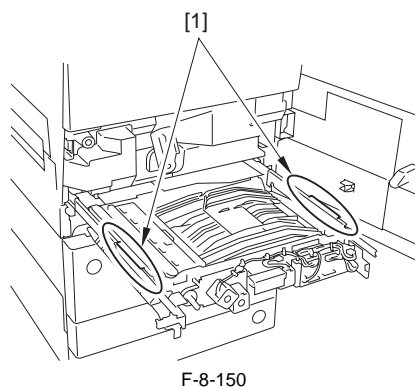

F-8-150

## 8.11.36 Duplex Feed Motor

### 8.11.36.1 Before Removing the Duplex Feeding Left Motor

iR5065 / iR 5055 / iR5075 / iR5075N / iR5065N / iR5055N

- 1) Detach the duplexing feed front cover. (page 10-14) Reference [Removing the Duplexing Feed Front Cover]
- 2) Remove the duplex feeding unit. (page 8-49) Reference [Removing the Duplex Feeding Unit]

### 8.11.36.2 Removing the Duplex Feeding Left Motor

iR5065 / iR 5055 / iR5075 / iR5075N / iR5065N / iR5055N

- 1) Remove the duplex feeding left motor [3].
  - 1 connector [1]
  - 2 screws [2]

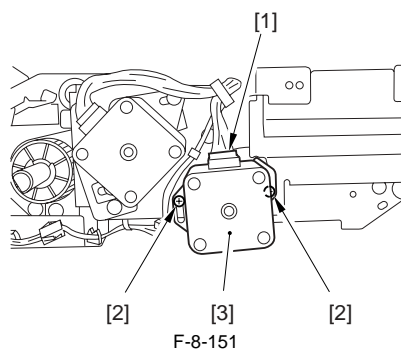

F-8-151

### 8.11.36.3 Before Removing the Duplex Feeding Right Motor

iR5065 / iR 5055 / iR5075 / iR5075N / iR5065N / iR5055N

- 1) Detach the duplexing feed front cover. (page 10-14) Reference [Removing the Duplexing Feed Front Cover]
- 2) Remove the duplex feeding unit. (page 8-49) Reference [Removing the Duplex Feeding Unit]

### 8.11.36.4 Removing the Duplex Feeding Right Motor

iR5065 / iR 5055 / iR5075 / iR5075N / iR5065N / iR5055N

- 1) Remove the duplex feeding right motor [3].
  - 1 connector [1]
  - 2 screws [2]

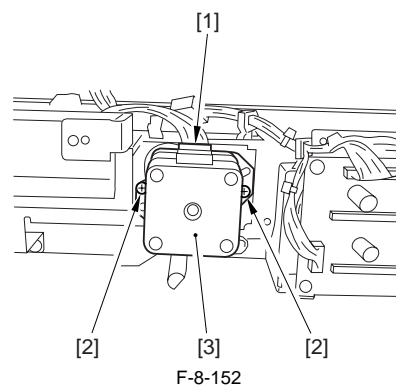

F-8-152

## 8.11.37 Duplex Feed Sensor

### 8.11.37.1 Before Removing the Duplex Pre-Registration Sensor

iR5065 / iR 5055 / iR5075 / iR5075N / iR5065N / iR5055N

- 1) Detach the duplexing feed front cover. (page 10-14) Reference [Removing the Duplexing Feed Front Cover]
- 2) Remove the duplex feeding unit. (page 8-49) Reference [Removing the Duplex Feeding Unit]

### 8.11.37.2 Removing the Duplex Pre-Registration Sensor

iR5065 / iR 5055 / iR5075 / iR5075N / iR5065N / iR5055N

- 1) Detach the cover [2].
  - 2 screws [1]

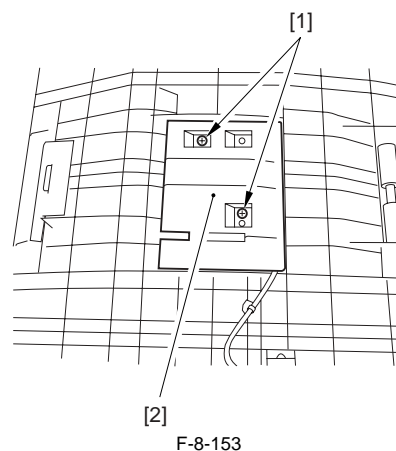

F-8-153

- 2) Detach the sensor together with the mount [3].
  - 2 screws [1]
  - 1 grounding wire [2]

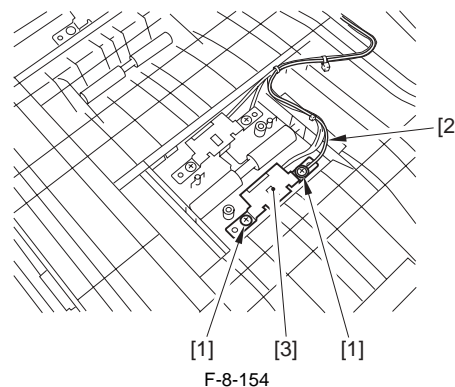

F-8-154

- 3) Remove the sensor [2].
  - 1 connector [1]

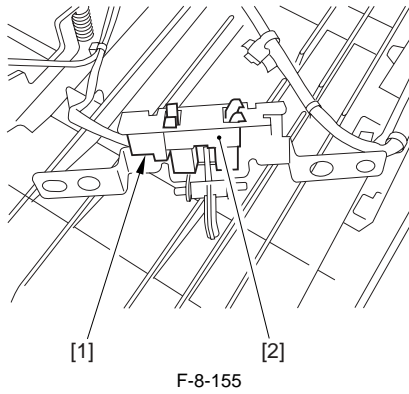

cassette 3/4, right deck pickup assembly

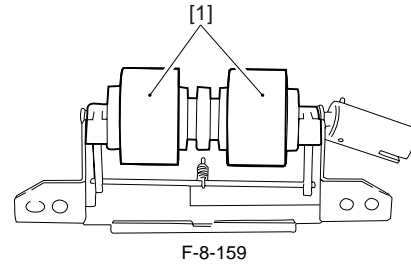

left deck pickup assembly

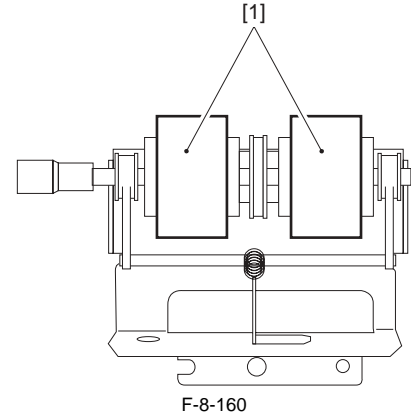

**8.11.38 Separation Roller**

**8.11.38.1 Before Removing the Separation Roller**

iR5065 / iR 5055 / iR5075 / iR5075N / iR5065N / iR5055N

- 1) Remove the right deck pickup assembly. (page 8-35) Reference[Removing the Right Deck Pickup Assembly]
- 2) Remove the cassette pickup assembly. (page 8-31) Reference[Removing the Cassette 3/4 Pickup Assembly]
- 3) Remove the left deck pickup assembly. (page 8-35) Reference[Removing the Left Deck Pickup Assembly]

**8.11.38.2 Removing the Separation Roller**

iR5065 / iR 5055 / iR5075 / iR5075N / iR5065N / iR5055N

- 1) Remove the open/close guide [3].
  - 2 mounting screws [1]
  - 1 feeding guide plate [2]
 (Skip this step for the left deck pickup assembly)

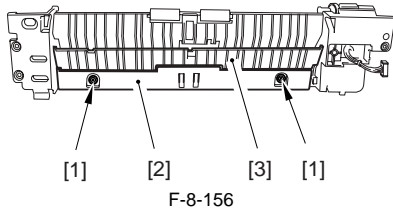

- 2) Remove the separation roller assembly [2] from the joint.
  - 2 mounting screws [1]
  - (For the left deck, remove one screw [3])
 cassette 3/4, right deck pickup assembly

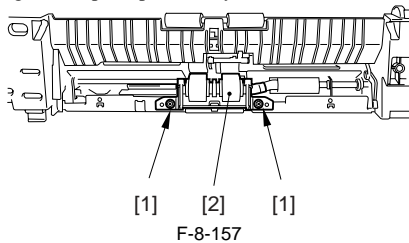

left deck pickup assembly

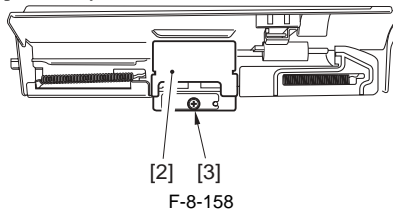

- 3) Remove the separation roller from the separation roller [1] shaft support mount.



The urethane sponge used for this part is pink at the beginning, and changes yellow over time (accelerated if exposed to light; it may appear to change orange before turning pink). This is the common characteristic of urethane sponge, and does not indicate physical deterioration (performance). In addition, notes that the part is not classified by color.

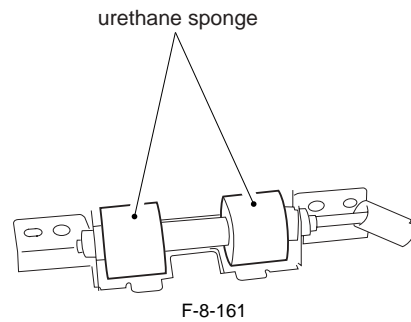

**8.11.38.3 Points to Note When Mounting the Separation Roller**

iR5065 / iR 5055 / iR5075 / iR5075N / iR5065N / iR5055N

When replacing the separation roller, be sure it is oriented as follows.



Mounting the separation roller in a wrong orientation may lead to interference against the crimping washer. Make sure it is mounted in a correct orientation.

Cassette 1/2, Right deck pickup assembly

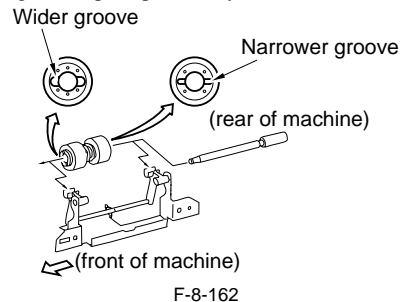



Left deck pickup assembly

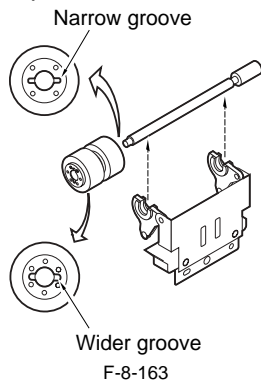

#### 8.11.38.4 Adjusting the Pressure of the Deck/Cassette Separation Roller

iR5065 / iR 5055 / iR5075 / iR5075N / iR5065N / iR5055N

When picking up, if double feeding or pickup failure occurs, adjust the position of the pressure spring in the separation roller.

- If double feeding occurs, move the hook of the spring in the direction of B.
- If pickup failure occurs, move the hook of the spring in the direction of A.

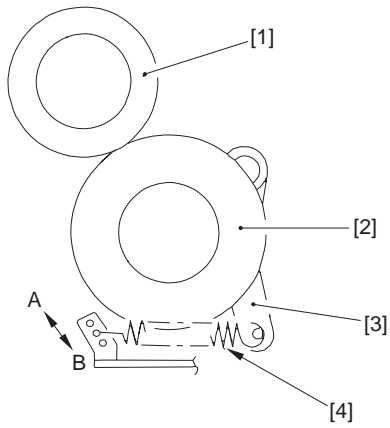

- [1] Feeding roller
- [2] Separation roller
- [3] Pressure lever
- [4] Pressure spring



---

## Chapter 9 Fixing System

---



# Contents

9.1 Construction .....	9-1
9.1.1 Specifications, Control Mechanisms, and Functions .....	9-1
9.1.2 Major Components.....	9-1
9.1.3 IH Fixing Method (outline).....	9-3
9.1.4 Limiting the Rise in Temperature at the Roller Edges by Use of a Flux blocking Plate (shutter).....	9-3
9.2 Basic Sequence .....	9-4
9.2.1 Outline.....	9-4
9.2.2 30-Sec Start-Up Mode .....	9-4
9.2.3 Low-Temperature Environment Start-Up Mode .....	9-5
9.2.4 High-Humidity Environment Start-Up Mode.....	9-5
9.2.5 Recovery Mode.....	9-6
9.2.6 Standby Mode .....	9-6
9.2.7 Power Save Mode .....	9-7
9.2.8 Sleep Mode .....	9-7
9.2.9 Copying/Printing Mode .....	9-7
9.2.10 Down Sequence .....	9-8
9.2.11 Enhanced Fixing Mode.....	9-8
9.2.12 Heavy Paper Mode.....	9-9
9.2.13 Transparency Mode .....	9-9
9.2.14 Bond Paper Mode .....	9-9
9.3 Various Control Mechanisms.....	9-10
9.3.1 Fixing Drive System .....	9-10
9.3.1.1 Controlling the Drive of the Fixing Roller.....	9-10
9.3.1.2 Controlling the Drive of the Fixing Inlet Guide.....	9-10
9.3.1.3 Controlling the Reciprocating Movement of the Thermistor.....	9-11
9.3.1.4 Controlling the Reciprocating Mechanism of the Upper Separation Claw.....	9-11
9.3.1.5 Controlling the Drive of the Shutter.....	9-12
9.3.1.6 Controlling the Shutter Position.....	9-13
9.3.2 Cleaning .....	9-14
9.3.2.1 Controlling the Drive of the Cleaning Web .....	9-14
9.3.2.2 Controlling the Mechanism Used to Detect the Remaining Length of the Cleaning Web .....	9-15
9.3.3 Detecting the Passage of Paper .....	9-16
9.3.3.1 Preventing Wrapping of Paper .....	9-16
9.4 Protective Functions.....	9-17
9.4.1 Detecting an Error Using the Thermistor.....	9-17
9.4.2 Detecting an Error Using the Thermal Switch.....	9-17
9.4.3 Errors.....	9-17
9.5 Parts Replacement Procedure.....	9-19
9.5.1 Fixing/Feeding Assembly .....	9-19
9.5.1.1 Before Removing the Fixing/Feeding unit.....	9-19
9.5.1.2 Removing the Fixing/Feeding unit.....	9-19
9.5.2 Fixing Unit .....	9-20
9.5.2.1 Before Removing the Fixing Upper Unit.....	9-20
9.5.2.2 Removing the Fixing Upper Unit.....	9-20
9.5.3 Pressure Roller .....	9-20
9.5.3.1 Before Removing the Pressure Roller.....	9-20
9.5.3.2 Removing the Pressure Roller.....	9-20
9.5.4 Upper Fixing Roller .....	9-21
9.5.4.1 Before Removing the Fixing Roller.....	9-21
9.5.4.2 Removing the Fixing Roller.....	9-21
9.5.4.3 Points to Note When Mounting the Fixing Roller .....	9-23
9.5.4.4 Applying Grease After Replacing the Fixing Roller.....	9-24

9.5.4.5 Adjusting the Nip Width.....	9-25
9.5.5 External Delivery Roller.....	9-25
9.5.5.1 Before Removing the External Delivery Roller.....	9-25
9.5.5.2 Removing the External Delivery Roller.....	9-25
9.5.6 Internal Delivery Roller.....	9-26
9.5.6.1 Before Removing the Internal Delivery Roller.....	9-26
9.5.6.2 Removing the Internal Delivery Roller.....	9-26
9.5.6.3 Points to Note When Mounting the Internal Delivery Roller.....	9-27
9.5.7 Main Thermistor.....	9-27
9.5.7.1 Before Removing the Main Thermistor/Shutter Thermistor.....	9-27
9.5.7.2 Removing the Main Thermistor/Shutter Thermistor.....	9-27
9.5.7.3 Points to Note When Mounting the Main Thermistor/Shutter Thermistor.....	9-28
9.5.8 Sub Thermistor.....	9-28
9.5.8.1 Before Removing the Sub Thermistor.....	9-28
9.5.8.2 Removing the Sub Thermistor.....	9-29
9.5.8.3 Points to Note When Mounting the Sub Thermistor.....	9-29
9.5.9 Thermal Switch.....	9-29
9.5.9.1 Before Removing the Thermal Switch.....	9-29
9.5.9.2 Removing the Thermal Switch.....	9-30
9.5.10 Fixing Heater.....	9-30
9.5.10.1 Before Removing the Fixing Heater Unit.....	9-30
9.5.10.2 Removing the Fixing Heater Unit.....	9-30
9.5.11 Fixing Cleaning Belt.....	9-32
9.5.11.1 Before Removing the Fixing Web.....	9-32
9.5.11.2 Removing the Fixing Web.....	9-32
9.5.11.3 Cleaning the fixing oil dish and the fixing cleaning belt guide.....	9-32
9.5.11.4 Mounting the Fixing Web.....	9-32
9.5.11.5 After Replacing the Fixing Web.....	9-33
9.5.12 Fixing Jam Sensor.....	9-33
9.5.12.1 Before Removing the Delivery Jam Sensor.....	9-33
9.5.12.2 Removing the Delivery Jam Sensor.....	9-33
9.5.13 Claw Jam Sensor.....	9-33
9.5.13.1 Before Removing the Claw Jam Sensor.....	9-33
9.5.13.2 Removing the Claw Jam Sensor.....	9-33
9.5.14 External Delivery Sensor.....	9-34
9.5.14.1 Before Removing the External Delivery Sensor.....	9-34
9.5.14.2 Removing the External Delivery Sensor.....	9-34
9.5.15 Internal Delivery Sensor.....	9-34
9.5.15.1 Before Removing the Internal Delivery Sensor.....	9-34
9.5.15.2 Removing the Internal Delivery Sensor.....	9-34
9.5.16 Fixing Inlet Sensor.....	9-34
9.5.16.1 Before Removing the Fixing Inlet Sensor.....	9-34
9.5.16.2 Removing the Fixing Inlet Sensor.....	9-34
9.5.16.3 Adjusting the Fixing Inlet Guide.....	9-35
9.5.17 Fixing web sensor.....	9-35
9.5.17.1 Before Removing the Fixing Web Sensor.....	9-35
9.5.17.2 Removing the Fixing Web Sensor.....	9-35
9.5.18 Fixing shutter sensor.....	9-35
9.5.18.1 Before Removing the Shutter Sensor.....	9-35
9.5.18.2 Removing the Shutter Sensor.....	9-35
9.5.19 Fixing shutter motor.....	9-35
9.5.19.1 Before Removing the Shutter Motor.....	9-35
9.5.19.2 Removing the Shutter Motor.....	9-35
9.5.20 Fixing Inlet Guide Solenoid.....	9-36
9.5.20.1 Before Removing the Fixing Inlet Guide Solenoid (SL1).....	9-36
9.5.20.2 Removing the Fixing Inlet Guide Solenoid (SL1).....	9-36
9.5.20.3 Adjusting the Fixing Inlet Guide Solenoid (SL1).....	9-36
9.5.21 Delivery Flapper Solenoid.....	9-36
9.5.21.1 Before Removing the Delivery Flapper Solenoid (SL5).....	9-36
9.5.21.2 Removing the Delivery Flapper Solenoid (SL5).....	9-36

---

9.5.21.3 Points to Note When Mounting the Delivery Flapper Solenoid (SL5).....	9-37
9.5.22 Fixing Cleaning Web Solenoid .....	9-37
9.5.22.1 Before Removing the Fixing Web Solenoid (SL9).....	9-37
9.5.22.2 Removing the Fixing Web Solenoid (SL9).....	9-37
9.5.22.3 Adjusting the Fixing Web Solenoid (SL9).....	9-37
9.5.23 Upper Separation Claw .....	9-37
9.5.23.1 Removing the Upper Separation Claw.....	9-37
9.5.23.2 Points to Note When Mounting the Upper Separation Claw .....	9-38
9.5.24 Lower Separation Claw.....	9-38
9.5.24.1 Before Removing the Lower Separation Claw (Unit).....	9-38
9.5.24.2 Removing the Lower Separation Claw (Unit) .....	9-39





## 9.1 Construction

### 9.1.1 Specifications, Control Mechanisms, and Functions

iR5065 / iR 5055 / iR5075 / iR5075N / iR5065N / iR5055N

The following shows the major functions of the machine's fixing system:

T-9-1

Item	Description
Fixing method	IH fixing
Fixing heater	IH heater
Fixing roller	40 mm dia., 0.65 mm thick
Pressure roller	38 mm outside dia.
Control temperature	decreased gradually from 205 deg C (at standby, 17 deg C or higher) decreased gradually from 215 deg C (at standby, lower than 17 deg C)
Fixing drive control	by fixing roller speed control (speed control according to paper type)
Fixing temperature detention	- Main Thermistor (THM1, contact) fixing roller center; 12 mm reciprocating width temperature control, error detection
	- Sub Thermistor (THM2, contact) fixing roller rear; no reciprocating mechanism shutter control, error detection
	- Shutter thermistor (THM3; contact) fixing roller rear; 12 mm reciprocating width shutter control, error detection
Protective mechanism	Executes the following error detection; in response to an error, cuts power to the fixing heater:
	- thermistor temperature detention (THM1/THM2/THM3)
	- thermal switch (TP1) operating temperature: 200 +/-5 deg C
Separation claw	upper separation claw: contact type (3 mm reciprocating width) lower separation claw: contact type (no reciprocating mechanism)
Bias application	no
Static eliminator	yes; for both fixing roller and pressure roller
Cleaning mechanism	oil application by web
Inlet guide	re-configured according to paper type/length
Extra-small size support	control of heating area by flux blocking plate (shutter)
Pressure release mechanism	no

### 9.1.2 Major Components

iR5065 / iR 5055 / iR5075 / iR5075N / iR5065N / iR5055N

The following shows the major components of the machine's fixing system:

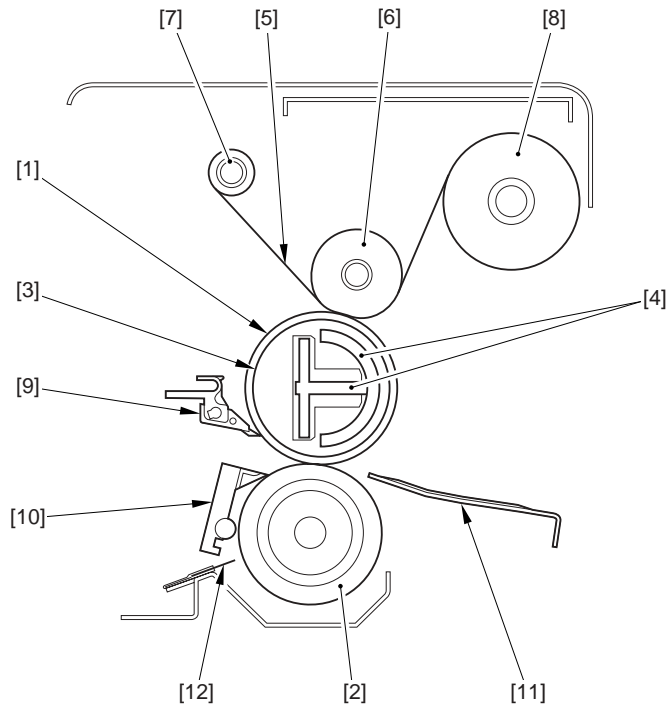

F-9-1  
T-9-2

- |                                  |                            |
|----------------------------------|----------------------------|
| [1] Fixing roller                | [7] Web takeup roller      |
| [2] Pressure roller              | [8] Web feed roller        |
| [3] Heater unit                  | [9] Upper separation claw  |
| [4] Heater assembly (coil, core) | [10] Lower separation claw |
| [5] Fixing cleaning web          | [11] Fixing inlet guide    |
| [6] Web roller                   | [12] Static eliminator     |

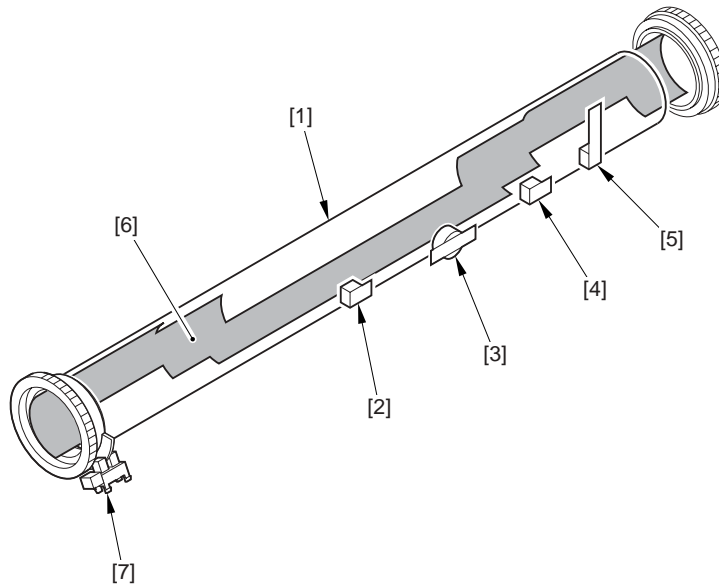

F-9-2  
T-9-3

- |                               |                                   |
|-------------------------------|-----------------------------------|
| [1] Fixing roller             | [5] Sub thermistor (THM2)         |
| [2] Main thermistor (THM1)    | [6] Flux blocking plate (shutter) |
| [3] Thermal switch (TP1)      | [7] Shutter HP sensor (PS53)      |
| [4] Shutter thermistor (THM3) |                                   |

### 9.1.3 IH Fixing Method (outline)

iR5065 / iR 5055 / iR5075 / iR5075N / iR5065N / iR5055N

The machine uses the IH fixing method.

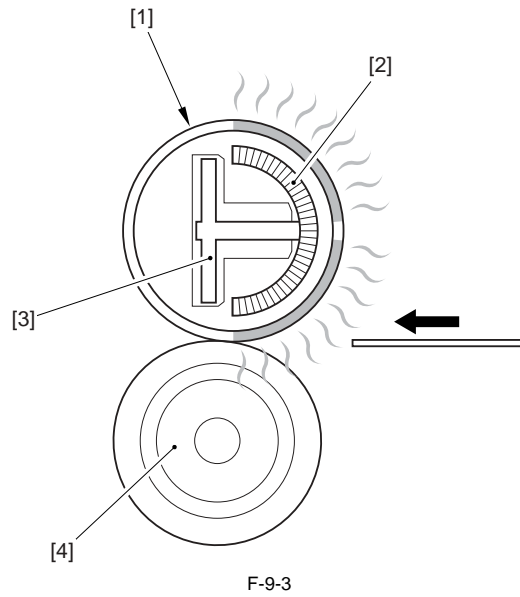

- [1] Fixing roller
- [2] Excitation coil
- [3] Core
- [4] Pressure roller

Note:

The arrow in the figure shows the direction of paper movement.

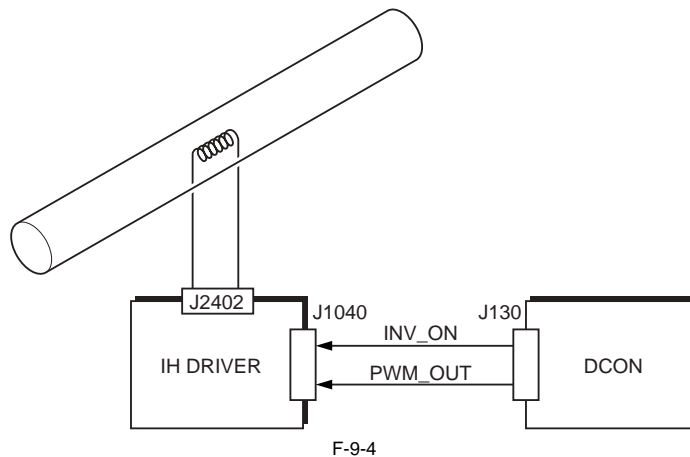

INV\_ON: fixing heater power ON signal  
 PWM\_OUT: fixing heater power supply control signal  
 DCON: DC controller PCB  
 IH DRIVER: fixing heater driver PCB

#### MEMO:

The term IH stands for "induction heating."

When high-frequency current is supplied to a coil arranged inside a heater unit, a high-frequency magnetic field develops around the coil. The field serves to permit the flow of eddy current (induction current) to the fixing roller, causing the roller to heat on its own.

Characteristics:

The use of the IH method enables the fixing roller to warm up quickly, permitting a reduction in warm-up time (30 sec) as well as of power consumption.

### 9.1.4 Limiting the Rise in Temperature at the Roller Edges by Use of a Flux blocking Plate (shutter)

iR5065 / iR 5055 / iR5075 / iR5075N / iR5065N / iR5055N

When small-size paper is used, the temperature of the areas of the fixing roller surface with which the paper will not come into contact will increase (overheating of the edges). To limit such a rise to a minimum, the machine is equipped with a flux blocking plate (shutter; made of non-magnetic material), and the fact helps maintain a high level of productivity when small-size paper is used.

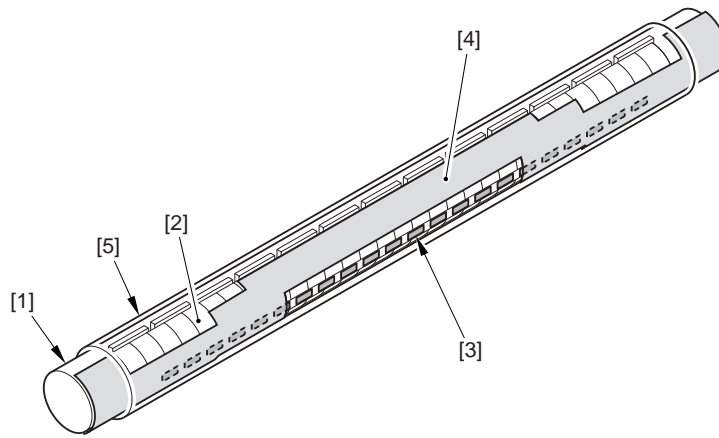

F-9-5

- [1] Heater coil
- [2] Coil
- [3] Core
- [4] Shutter (The figure shows the position of the shutter for small-size paper.)
- [5] Fixing roller

## 9.2 Basic Sequence

### 9.2.1 Outline

iR5065 / iR 5055 / iR5075 / iR5075N / iR5065N / iR5055N

T-9-4

State	Sequence	Description
At power-on	30-sec start-up mode	When all the following conditions exist: - the environment temperature is 17 deg C or higher - the site is a low-humidity environment - the temperature of the fixing roller is 70 deg C or lower
	Low-temperature start-up mode	When all the following conditions exist: - the site is a high-humidity environment - the temperature of the fixing roller is 70 deg C or lower
	High humidity environment start-up mode	This mode is used when all the following conditions exist: - the site is in a high humidity environment. - the temperature of the fixing roller is 70 deg C or lower.
	Recovery mode	The temperature of the fixing roller is 70 deg C or higher.
In wait	Standby mode	To limit power consumption, the target temperature is decreased at specific time intervals after the end of start-up.
	Power save mode	To limit power consumption, the target temperature is decreased.
	Sleep mode	To limit power consumption, the target temperature is decreased at specific time intervals after the end of start-up.
In normal use	Copier/printer mode	To limit power consumption, the target temperature is decreased at specific time intervals after the end of start-up.
	Down sequence	None
Special mode	Fixing enhancement mode	To enhance fixing, the machine changes the start-up sequence and the control temperature.
	Heavy paper mode	To ensure fixing on heavy paper, the machine changes the target temperature and copying/printing speed.
	Transparency mode	To ensure fixing on transparencies, the target temperature is increased.
	Bond paper mode	To ensure fixing for bond paper, machine increases the target temperature in a low-temperature environment while decreasing the copying/printing speed.

### 9.2.2 30-Sec Start-Up Mode

iR5065 / iR 5055 / iR5075 / iR5075N / iR5065N / iR5055N

#### <Conditions of Use>

- When all the following conditions exist:
- the environment temperature is 17 deg C or higher.
  - the site is a low-humidity environment (absolute moisture content is 13 g or less)
  - the temperature of the fixing roller is 70 deg C or less

#### <Characteristics>

The target temperature of the fixing roller is 205 deg C.  
However, the machine shifts to standby mode regardless of whether the temperature of the fixing roller reaches the target or not when 29.5 sec passes after power-on.

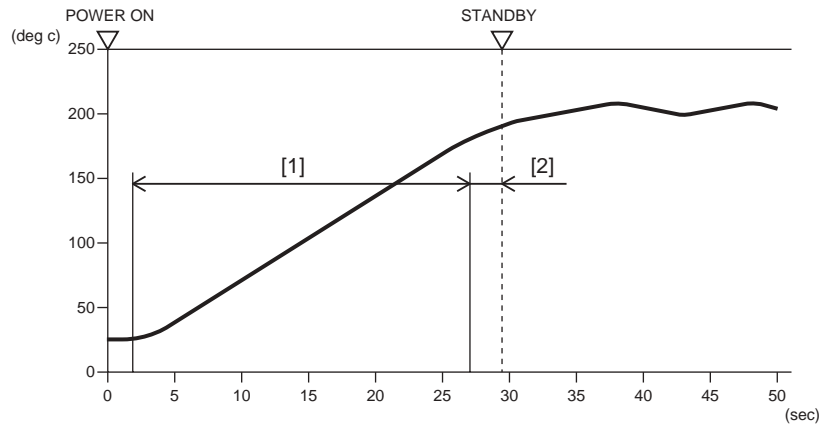

F-9-6

- [1] Fixing roller 1/4-speed rotation  
[2] Fixing roller 1/1-speed rotation

### 9.2.3 Low-Temperature Environment Start-Up Mode

iR5065 / iR 5055 / iR5075 / iR5075N / iR5065N / iR5055N

#### <Conditions of Use>

When all the following conditions exist:

- the environment temperature is lower than 17 deg C
- the temperature of the fixing roller is 70 deg C or lower

#### <Characteristics>

- The target temperature for the fixing roller is 215 deg C.
- If all the following conditions exist, the machine shifts to standby mode:
  - the temperature of the fixing roller has reached the target temperature.
  - potential control has ended
- The machine takes 75 sec or less to move from power-on to standby states. (reference only)

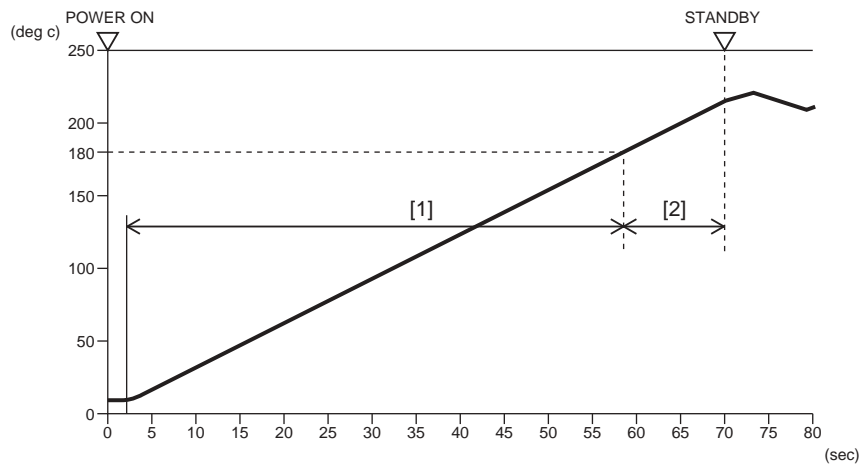

F-9-7

- [1] Fixing roller 1/4-speed rotation  
[2] Fixing roller 1/1-speed rotation

### 9.2.4 High-Humidity Environment Start-Up Mode

iR5065 / iR 5055 / iR5075 / iR5075N / iR5065N / iR5055N

#### <Conditions of Use>

When all the following conditions exist:

- the site is a high-humidity environment (absolute moisture content is 13 g or more)
- the temperature of the fixing roller is 70 deg C or lower

#### <Characteristics>

- The target temperature for the fixing roller is 205 deg C.
- If all the following condition exist, the machine shifts to standby mode:
  - the temperature of the fixing roller has reached the target temperature.
  - drum potential control has ended.
  - 60 sec (\*1) has passed from power-on.

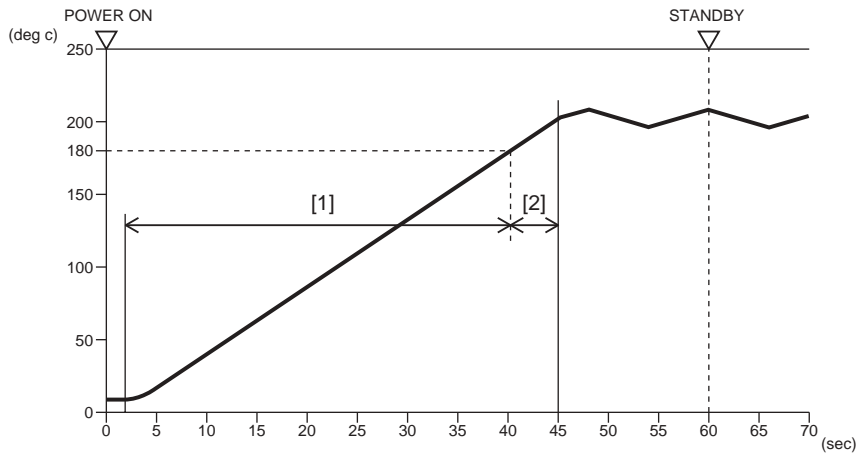

F-9-8

- [1] Fixing roller 1/4-speed rotation
- [2] Fixing roller 1/1-speed rotation

### 9.2.5 Recovery Mode

iR5065 / iR 5055 / iR5075 / iR5075N / iR5065N / iR5055N

<Conditions of Use>

- The temperature of the fixing roller is 70 deg C or higher.

<Characteristics>

- The target temperature of the fixing roller varies according to the environment temperature.
  - 185 deg C if the environment temperature is 17 deg C or higher
  - 195 deg C if the environment temperature is lower than 17 deg C
- When the temperature of the fixing roller reaches the target temperature, the machine shifts to standby mode.
  - It takes 30 sec less for the machine to shift from power-on to standby states.

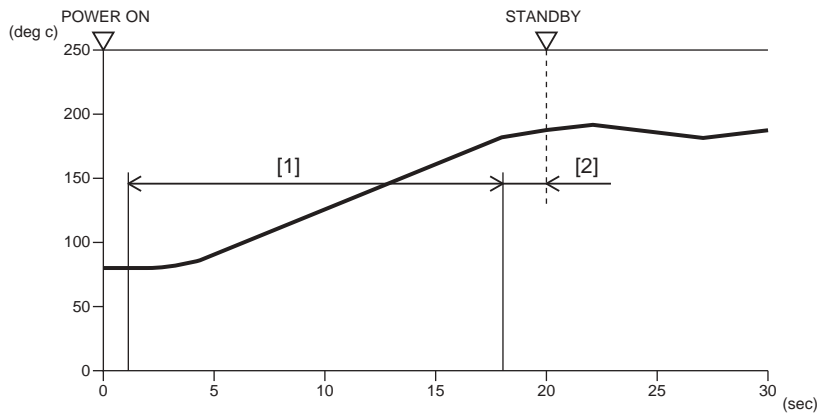

F-9-9

- [1] Fixing roller 1/4-speed rotation
- [2] Fixing roller 1/1-speed rotation

### 9.2.6 Standby Mode

iR5065 / iR 5055 / iR5075 / iR5075N / iR5065N / iR5055N

<Characteristics>

- The machine decreases the target temperature by 5 deg C at specific time intervals after a shift to standby mode (to limit power consumption).
- The target temperature and the timing at which it is changed vary depending on the environment temperature (lower than or higher than 17 deg C).
- The target temperature is decreased in steps and, thereafter, maintained to the following:
  - 185 deg C if the environment temperature is less than 17 deg C
  - 180 deg C if the environment temperature is 17 deg C or higher

- If the environment temperature is lower than 17 deg C,

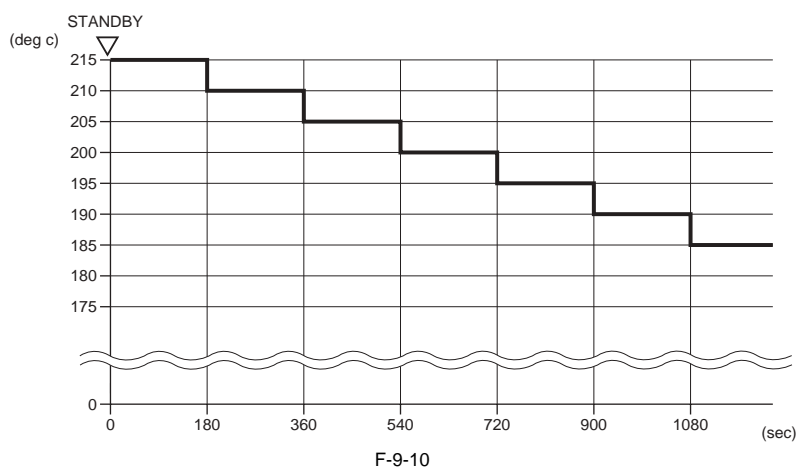

- If the environment temperature is 17 deg C or higher,

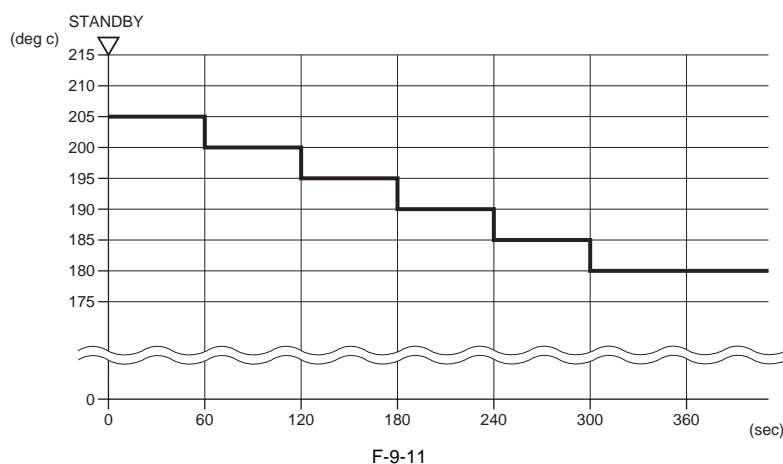

**MEMO:**

The time that passes from a shift to standby mode is monitored continuously while a copy/print job is under way, and is used for temperature control for copying/printing. (See the descriptions under "Copying/Printing Mode.")

### 9.2.7 Power Save Mode

iR5065 / iR 5055 / iR5075 / iR5075N / iR5065N / iR5055N

<Characteristics>

- The machine uses the appropriate target temperature for the fixing roller to suit the selected rate of power saving (in user mode).
- The machine uses the appropriate target temperature for the fixing roller to suit the selected rate of power saving (in user mode).

T-9-5

Rate of saving	Standard temperature	Time length to standby
-10% (default)	170 deg C	4 sec or less
-25%	160 deg C	6 sec or less
-50%	140 deg C	8 sec or less

### 9.2.8 Sleep Mode

iR5065 / iR 5055 / iR5075 / iR5075N / iR5065N / iR5055N

<Characteristics>

- The power to the fixing assembly is cut.
- When the sleep mode is disabled, the machine shifts to standby mode through the start-up mode effective at time of power-on (30-sec start-up, low-temperature environment start-up, high-humidify start-up, recovery).

### 9.2.9 Copying/Printing Mode

iR5065 / iR 5055 / iR5075 / iR5075N / iR5065N / iR5055N

<Characteristics>

- The target temperature used while copying/printing is under way is +2 deg C in relation to the temperature used for standby.

- If the environment temperature is lower than 17 deg C

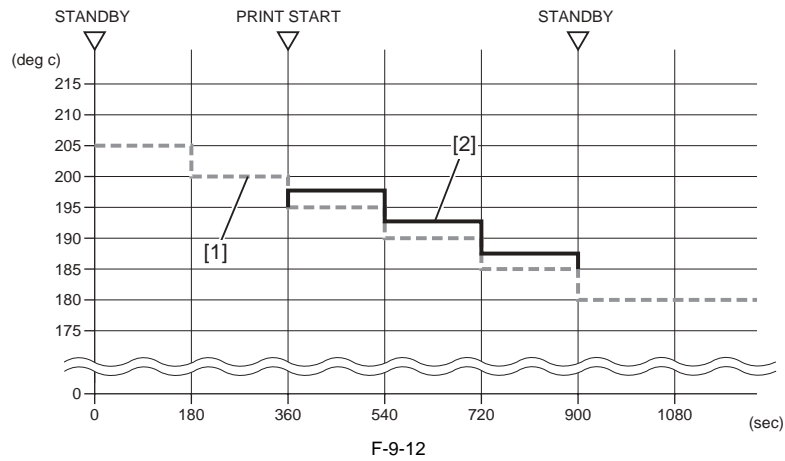

[1] temperature of the fixing roller (deg C)  
 [2] control temperature during copying

- If the environment temperature is 17 deg C or higher

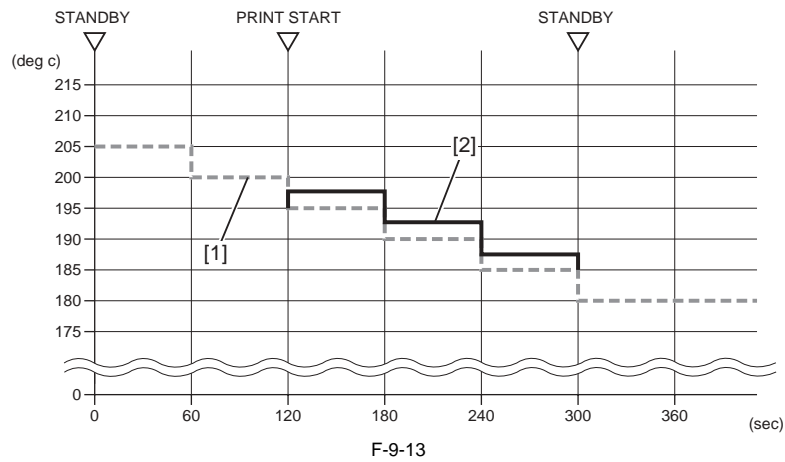

[1] temperature of the fixing roller (deg C)  
 [2] control temperature during copying

**9.2.10 Down Sequence**

iR5065 / iR 5055 / iR5075 / iR5075N / iR5065N / iR5055N

The machine does not have a down sequence.

**9.2.11 Enhanced Fixing Mode**

iR5065 / iR 5055 / iR5075 / iR5075N / iR5065N / iR5055N

To ensure good fixing, the machine changes the control temperature between start-up sequence and standby.

<Conditions of Use>

The mode (i.e., enhanced fixing mode) is selected in service mode.

<Characteristics>

The machine uses different target temperatures between start-up sequence and standby mode.

T-9-6

		at power-on		target temperature for standby mode
		start-up sequence	time used (ref.)	
normal mode	if the temperature of the environment is 17 deg C or higher	30-sec start-up mode, or high humidity environment start-up mode	60 sec (in high humidity environment start-up mode)	See descriptions under "Standby Mode."
	if the temperature of the environment is lower than 17 deg C	low temperature environment start-up mode	75 sec or less	
fixing enhancement mode	if the temperature of the environment is 17 deg C or higher	high humidity environment start-up mode	60 sec	normal standby mode + 10 deg C
	if the temperature of the environment is lower than 17 deg C	low temperature environment start-up mode	120 sec or less	same as normal mode



**SERVICE MODE:****COPIER>OPTION>BODY>FSPD-S1 (Category 2)**

Use it to select enhanced fixing mode:

0: normal (default)

1: enhanced fixing mode

2: not used

**MEMO:**

If both enhanced fixing mode and heavy paper mode (or, transparency mode) are selected at the same time, heavy paper mode (transparency mode) will be given priority.

**9.2.12 Heavy Paper Mode**

iR5065 / iR 5055 / iR5075 / iR5075N / iR5065N / iR5055N

The machine increases fixing temperature and changes the copying/printing speed to ensure fixing on heavy paper.

## &lt;Conditions of Use&gt;

A cassette for which heavy paper has been selected is used as the source of paper.

## &lt;Characteristics&gt;

- The target temperature differs depending on the environment temperature:
  - if the environment temperature is 17 deg C or higher,
    - > +12 deg C in relation to the target temperature.
  - if the environment temperature is lower than 17 deg C,
    - > 217 deg C.
- The machine starts to feed paper when the reading of the main thermistor becomes identical to the target temperature.
- The copying/printing speed is as follows:
  - pickup from the cassette
    - > 55 cpm/ppm
  - pickup from the manual feeder
    - > 44 cpm/ppm
- If the environment temperature is lower than 17 deg C, the machine decreases the target temperature by 5 deg C every 3 min after paper feed (to as low as 192 deg C).
- If the environment temperature is 17 deg C or higher, the machine decreases the target temperature by 5 deg C every 1 min after paper feed (to as low as 192 deg C).
- If the environment temperature is less than 17 deg C, the machine executes idle rotation of the fixing roller for 1 min (to collect heat in the fixing assembly) before starting copying/printing operation.
- If heavy paper exists together with plain paper for output, the machine holds paper at the point of registration until the target temperature for heavy paper is reached.
- If plain paper is picked up while the machine is in heavy paper mode, the machine will use the target temperature for heavy paper for fixing.

**9.2.13 Transparency Mode**

iR5065 / iR 5055 / iR5075 / iR5075N / iR5065N / iR5055N

The machine increases the fixing temperature to ensure good fixing on transparencies.

## &lt;Conditions of Use&gt;

- The paper type is identified as being "transparency" for the manual feed tray while the tray is used as the source of paper.

## &lt;Characteristics&gt;

The target temperature of the fixing roller is 217 deg C.

- The machine starts paper feed when the reading of the main thermistor becomes identical to the target temperature.
- the copying/printing speed is 44 cpm/ppm.
- if the environment temperature is lower than 17 deg C, the machine starts output 1 min after the end of start-up mode (executes initial rotation for 1 min).
- If a transparency exists among plain paper for output, the machine will hold the paper at the point of registration until the target temperature is reached.
- If plain paper is picked up while the machine is in transparency mode, the machine will continue to use the target temperature for transparencies for fixing.

If a transparency tends to wrap around the fixing roller when the machine is in transparency mode, you can improve separation by decreasing the fixing target temperature for transparency mode using the following service mode item:

**SERVICE MODE:****COPIER>OPTION>BODY>OHP-TEMP (Category 2)**

0: normal (default)

1: -5 deg C

2: -10 deg C

3: -15 deg C

4: -20 deg C

**9.2.14 Bond Paper Mode**

iR5065 / iR 5055 / iR5075 / iR5075N / iR5065N / iR5055N

The machine increases the fixing temperature while decreasing the copying/printing speed in a low-temperature environment to ensure fixing on bond paper.

## &lt;Conditions of Use&gt;

A cassette selected for bond paper is used as the source of paper.

## &lt;Characteristics&gt;

- if the environment temperature is 17 deg C or higher,
  - the target temperature is 205 deg C (same as normal copying/printing mode)
- if the environment temperature is lower than 17 deg C,
  - the target temperature is 210 deg C
- the copying/printing speed is 30 cpm/ppm

## 9.3 Various Control Mechanisms

### 9.3.1 Fixing Drive System

#### 9.3.1.1 Controlling the Drive of the Fixing Roller

iR5065 / iR 5055 / iR5075 / iR5075N / iR5065N / iR5055N

The following shows the construction of the mechanisms used to control the drive of the fixing roller:

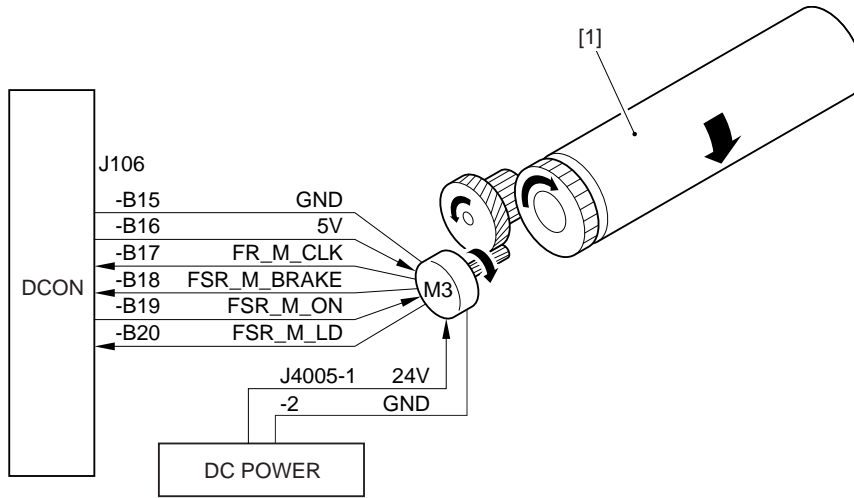

F-9-14

FR\_M\_CLK: fixing motor clock signal  
 FSR\_M\_BRAKE: fixing motor brake signal  
 FSR\_M\_ON: fixing motor drive signal  
 FSR\_M\_LD: fixing motor drive lock signal

[1] Fixing roller  
 M3: fixing motor  
 DCON: DC controller PCB  
 DC POWER: DC power supply PCB

#### ERROR CODE:

##### E014 (fixing motor error)

0000 After the fixing motor has gone on, the machine does not detect the phase lock signal for the fixing motor for 2 sec or more.

#### 9.3.1.2 Controlling the Drive of the Fixing Inlet Guide

iR5065 / iR 5055 / iR5075 / iR5075N / iR5065N / iR5055N

The machine controls the height of the fixing inlet guide to suit the type and size of paper being in use, thus preventing the trailing edge of paper from snapping up, rubbing, or wrinkling.

The following shows the mechanisms associated with the drive of the fixing inlet guide.

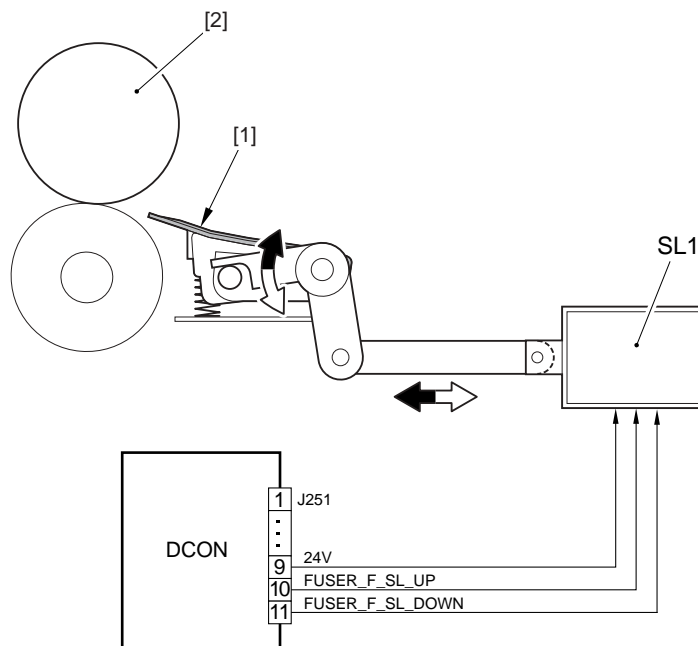

F-9-15

FUSER\_F\_SL\_UP: fixing inlet guide UP signal

FUSER\_F\_SL\_DOWN:fixing inlet guide DOWN signal

[1] Fixing inlet guide  
 [2] Fixing roller  
 DCON: DC controller PCB  
 SL1: Fixing inlet guide solenoid

The following shows the position (up/down) of the fixing inlet guide controlled to suit the type/size of paper being in use:

T-9-7

Paper type	Paper length	Inlet guide position
Plain paper	less than 257 mm	down
	257 mm or more	up
Heavy paper	-	down

#### ERROR CODE:

##### E841 (fixing inlet guide solenoid connection detection error)

0001 At power-on, the connection of the fixing inlet guide solenoid is not detected.

### 9.3.1.3 Controlling the Reciprocating Movement of the Thermistor

iR5065 / iR 5055 / iR5075 / iR5075N / iR5065N / iR5055N

To prevent damage to the fixing roller by the main thermistor (THM1) or the shutter thermistor (THM3), the thermistor is moved in the axial direction of the fixing roller over a distance of about 12 mm.

The thermistor is moved by the drive from the web drive solenoid (SL9), transmitted to the reciprocating cam by way of a one-way arm.

The following shows the components associated with the mechanism used to control the thermistor reciprocating mechanism:

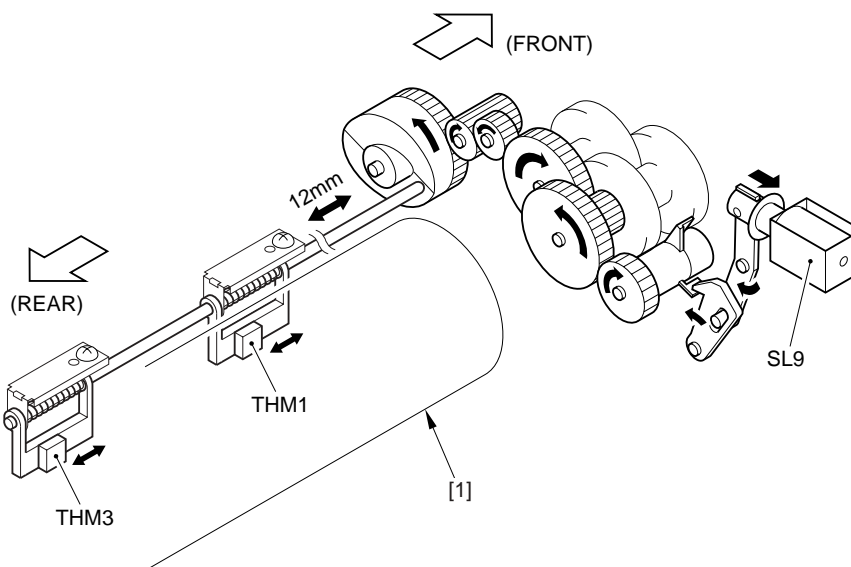

F-9-16

[1] Fixing roller  
 SL9: web drive solenoid  
 THM1: main thermistor  
 THM3: shutter thermistor

### 9.3.1.4 Controlling the Reciprocating Mechanism of the Upper Separation Claw

iR5065 / iR 5055 / iR5075 / iR5075N / iR5065N / iR5055N

To prevent damage to the fixing roller by the upper separation claw, the upper separation claw is moved back and forth over a distance of 3 mm in the axial direction of the fixing roller.

The following shows the construction of the components used to control the upper separation claw reciprocating mechanism.

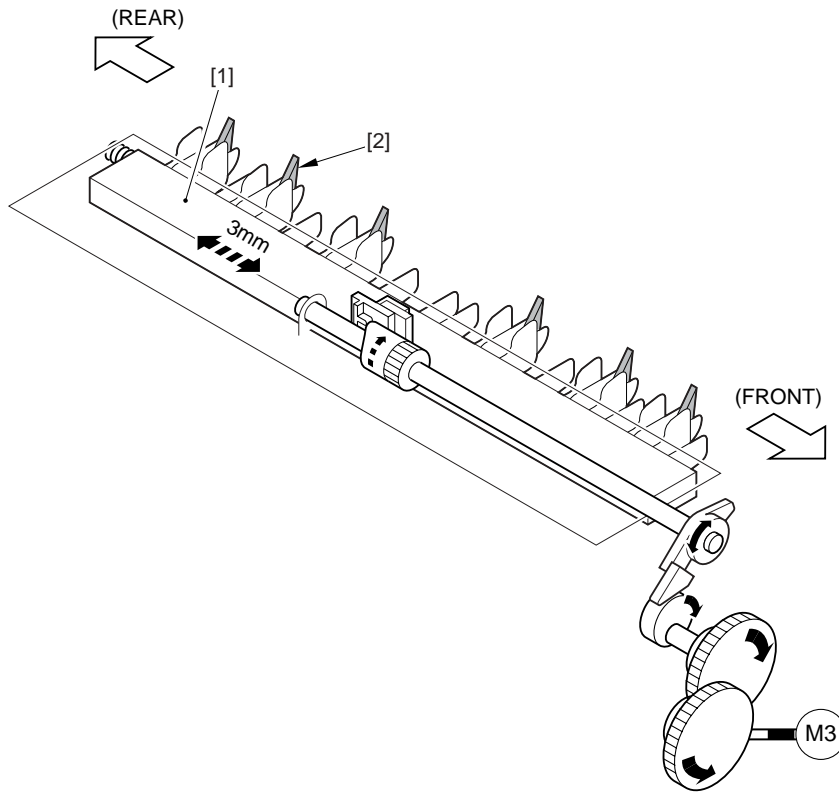

F-9-17

- [1] Upper separation claw unit
- [2] Upper separation claw
- M3: Fixing motor

### 9.3.1.5 Controlling the Drive of the Shutter

iR5065 / iR 5055 / iR5075 / iR5075N / iR5065N / iR5055N

The following shows the construction of the mechanisms used to control the drive of the shutter:

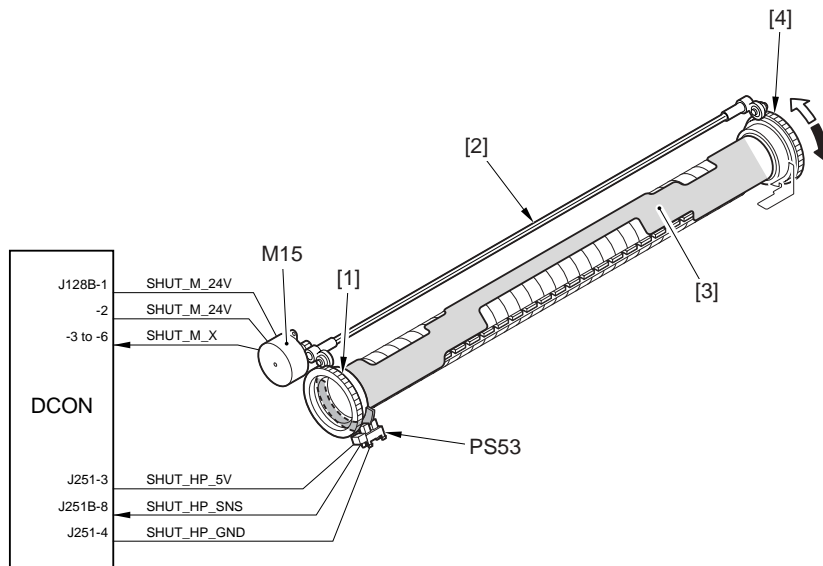

F-9-18

SHUT\_M\_X: shutter motor drive signal  
 SHUT\_HP\_SNS: shutter HP sensor signal

- [1] Shutter drive gear (front)
- [2] Drive axis
- [3] Shutter
- [4] Shutter drive gear (rear)

DCON: DC controller PCB  
 M15: shutter motor  
 PS53: shutter HP sensor

The shutter is driven by the shutter motor (stepping motor), and the shutter HP sensor (PS53) is used to check to see if the shutter is set at the appropriate position.

**ERROR CODE:**

**E840 (shutter error)**

0001 Indicates that the HP sensor signal is not detected when the shutter is operating, after executing 3 retry operations.  
 0002 The interval of ON-OFF detection by the sensor in response to shutter operation is shorter than a specific time period.

**9.3.1.6 Controlling the Shutter Position**

iR5065 / iR 5055 / iR5075 / iR5075N / iR5065N / iR5055N

The shutter is set to the appropriate position by driving the shutter motor (stepping motor) for a specific number of steps. A cut-off is found in the periphery of the shutter gear (front) operating in conjunction with the shutter; the machine checks to see if the shutter is set to the appropriate position with reference to the output of the shutter HP sensor (PS53), i.e., whether the sensor has detected the cut-off.

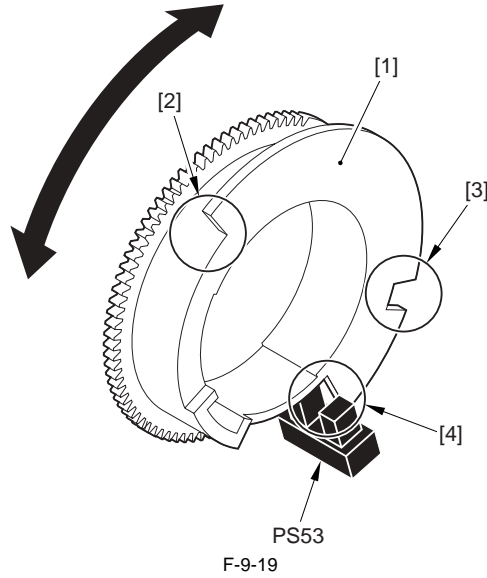

- [1] Shutter drive gear (front)
- [2] Cut-off (for HP detection)
- [3] Cut-off (for medium-size paper detection)
- [4] Cut-off (for small-size paper detection)
- PS53: shutter HP sensor

The following shows the position of the shutter (3 steps). The machine moves the shutter to the appropriate position to suit the size of the paper and the reading of the thermistor in question.  
 ([1] in the diagram indicates the shutter.)

- Home Position (HP)

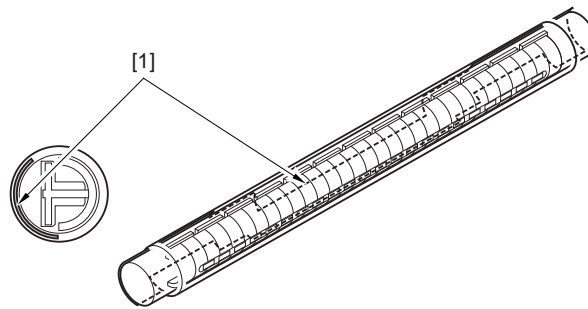

- Medium-Size Paper Position

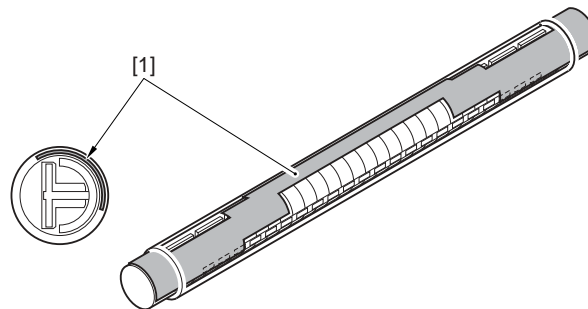

- Small-Size Paper Position

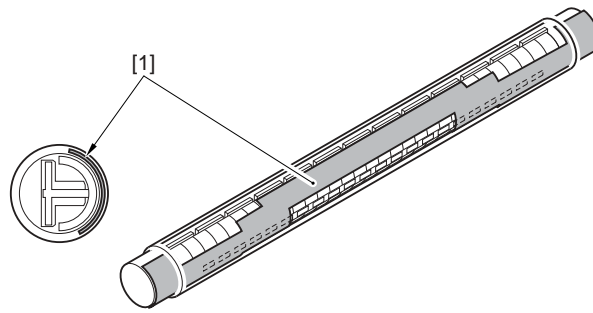

F-9-22

<Sequence of Shutter Operation>

- At Power-On

The machine moves the shutter (round trip) between home position and small-size paper position to check shutter operation.

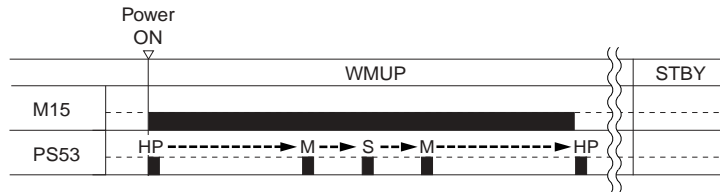

F-9-23

- HP : shutter position (home position)
- M : shutter position (medium-size paper position)
- S : shutter position (small-size paper position)
- M15 : shutter motor
- PS53: shutter HP sensor

- During Copying/Printing

At time of standby, the machine sets the shutter to its home position; during copying/printing, on the other hand, the machine controls the shutter position according to the selected paper size and the readings of the sub thermistor and the shutter thermistor. After copying/printing, the machine moves the shutter back to its home position.

Here, the discussion is based on shutter operation when the machine is making A5R prints in continuous mode.

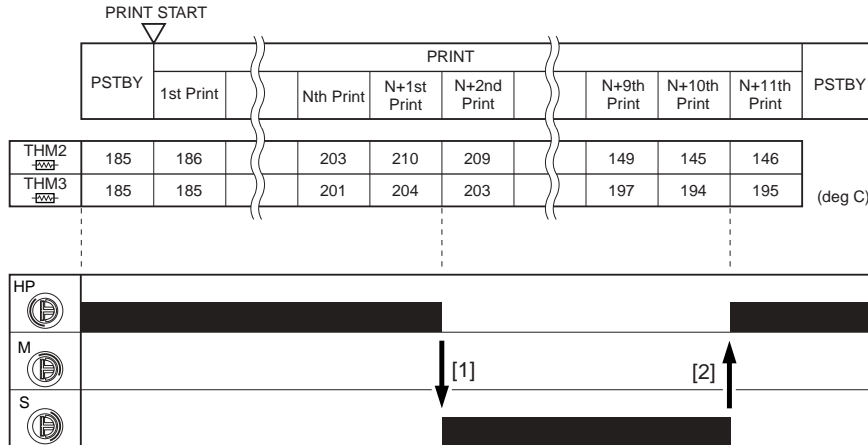

F-9-24

- [1] When printing starts, the readings of the sub thermistor (THM2) and the shutter thermistor (THM3) are both above specific levels (THM2/THM3 >= 203 deg C); as a result, the machine moves the shutter to small-size paper position (S).
- [2] The machine continues printing operation. Consequently, the readings of both thermistor are below specific levels (120 deg C <= THM2 < 150 deg C, 165 deg C <= THM3 < 195 deg C); as a result, the machine moves the shutter to home position.

**MEMO:**

The foregoing chart has been prepared to illustrate the operation of the shutter, and the readings of the thermistor do not necessarily fluctuate as shown in the chart.

**9.3.2 Cleaning**

**9.3.2.1 Controlling the Drive of the Cleaning Web**

iR5065 / iR 5055 / iR5075 / iR5075N / iR5065N / iR5055N

The machine removes toner remaining on the fixing roller by means of cleaning web (impregnated with silicone oil) to prevent fixing offset. The cleaning web is taken up by the takeup roller when the drive from the fixing web solenoid (SL9) reaches the web takeup roller drive gear by way of a one-way clutch.

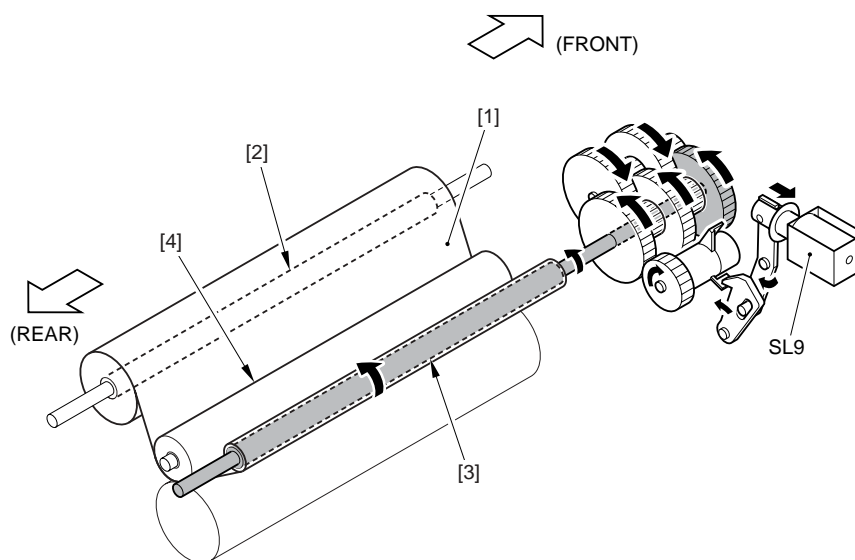

F-9-25

- [1] Cleaning web
- [2] Web feed roller
- [3] Web takeup roller
- [4] Web roller
- SL9: web drive solenoid

The length of takeup is determined by the size of the paper used and the number of prints (within a single job).

T-9-8

Paper		Number of web SL activations
small-size*1	1st sheet	once
	2nd sheet	once
	3rd sheet	0 times
	-	Thereafter, repeated.
Large-size*2	1st sheet	twice
	2nd sheet	once
	3rd sheet	once
	-	Thereafter, repeated.

\*1: A4/A4R/B5/B5R/A5R/LTR/LTRR

\*2: A3/B4/LGR/LGL

If paper exits in the fixing assembly because of a jam or error, the machine turns on the web solenoid 5 times at time of recovery (so as to prevent wrapping of the cleaning web around the fixing roller).

---

#### ERROR CODE:

##### E005 (fixing web solenoid connection detection error)

0001 Indicates that, at time of power-on, the connection of the fixing web solenoid is not detected.

---

#### SERVICE MODE:

##### COPIER>OPTION>BODY>CBLTINVL

Use it to set the number of times the fixing web solenoid goes on.

Use it if an image fault occurs as a result of soiling on the pressure roller.

0: normal (default)

1: twice as often as normal

---

### 9.3.2.2 Controlling the Mechanism Used to Detect the Remaining Length of the Cleaning Web

iR5065 / iR 5055 / iR5075 / iR5075N / iR5065N / iR5055N

The remaining length of the cleaning web is detected as follows:

- 1) The fixing web comes wrapped around the web feed roller, and is collected by the web takeup roller as copies/prints are made.
- 2) When the fixing web on the web feed roller decreases to a specific length, the cut-off in the web length detecting arm starts to move in the direction of the arrow, causing the arm to block the optical path of the web length sensor (PS45). The machine will issue a fixing web length warning message on the control panel

when the fixing web solenoid goes on 4 times after the sensor has gone on.

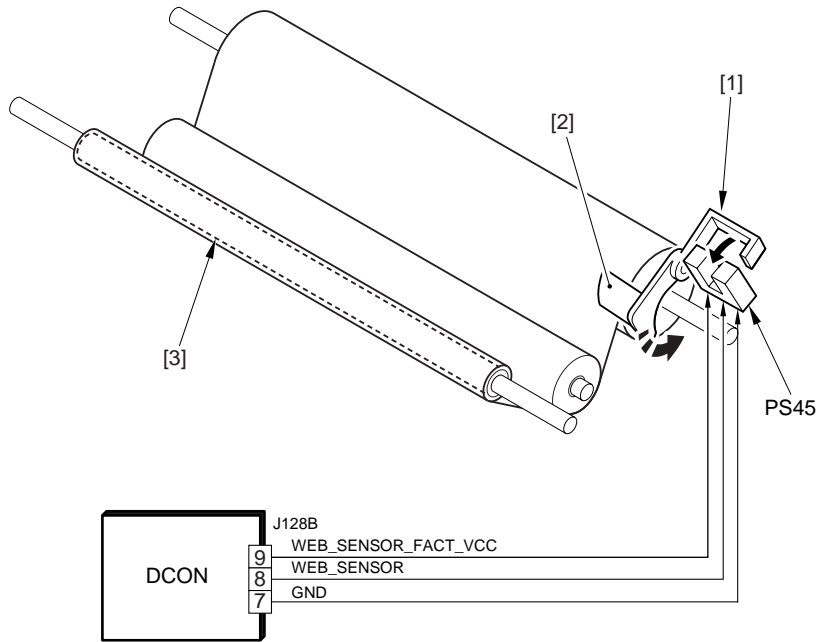

F-9-26

WEB\_SENSOR: fixing web length detection signal

- [1] Web length detecting arm
- [2] Cut-off
- [3] Web takeup roller

DON: DC controller PCB  
 PS45: web length sensor

3) When copies/prints are made after the message has been issued, the machine starts to monitor the count (COPIER>COUNTER>MISC>FIX-WEB; fixing web counter). When the count reaches '2000' (in terms of A4, 3000 copies/prints), the machine issues error code 'E005'.

**SERVICE MODE:**

**COPIER>OPTION>USER>WEB-DISP**

Use it to enable/disable the web length warning message:

- 0: off (however, the message will be indicated on the service mode screen)
- 1: on (default)

**COPIER>COUNTER>MISC>FIX-WEB**

**COPIER>COUNTER>DRBL-1>FX-WEB**

fixing web counter



If you have replaced the fixing web, be sure to reset the following counter readings to '0':

- **COPIER>COUNTER>MISC>FIX-WEB**
- **COPIER>COUNTER>DRBL-1>FX-WEB**

**ERROR CODE:**

**E005 (no web)**

0000 Indicates that the absence of the fixing web is detected for 5 sec or more.

**9.3.3 Detecting the Passage of Paper**

**9.3.3.1 Preventing Wrapping of Paper**

iR5065 / iR 5055 / iR5075 / iR5075N / iR5065N / iR5055N

To prevent warping of paper around the fixing roller, the machine will execute an emergency stop on the fixing motor if paper exits inside the fixing assembly with a delay jam at the outlet of the assembly.

The presence/absence of paper inside the fixing assembly is assumed with reference to the history of detection (paper at the fixing inlet sensor, i.e., in terms of whether paper has moved past the sensor).



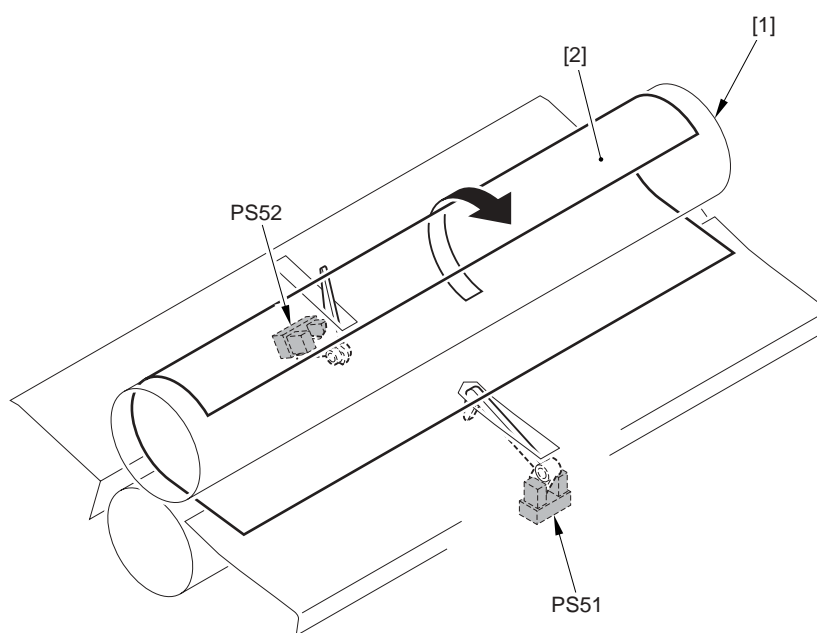

F-9-27

[1] Fixing roller  
 [2] Paper  
 PS51: fixing inlet sensor  
 PS52: fixing outlet sensor

## 9.4 Protective Functions

### 9.4.1 Detecting an Error Using the Thermistor

iR5065 / iR 5055 / iR5075 / iR5075N / iR5065N / iR5055N

In the event of the following, the machine will set the DC power (+12 V) used to drive the AC relay (found on the fixing heater power supply PCB), thereby stopping the AC power to the fixing heater.

- the main thermistor (TH1)/sub thermistor (TH2)/shutter thermistor (TH3) has detected overheating.
- the difference between readings of the main thermistor and the sub thermistor or between the main thermistor and the shutter thermistor has deviated from a specific value.

### 9.4.2 Detecting an Error Using the Thermal Switch

iR5065 / iR 5055 / iR5075 / iR5075N / iR5065N / iR5055N

In response to a deviation in temperature (200 +/-5 deg C), bimetal contact of the thermal switch (TP1; non-contact type) will open to cut the power supply line (+12 VDC) used to drive the AC relay on the fixing heater power supply PCB, thereby stopping the AC power to the fixing heater.



Once open, the contact of the thermal switch will not reset itself even when the temperature drops to normal; be sure to replace the thermal switch after removing the error.

### 9.4.3 Errors

iR5065 / iR 5055 / iR5075 / iR5075N / iR5065N / iR5055N

#### ERROR CODE:

#### E000 (low temperature detection error)

- 0000 after power-on, the reading of the main thermistor is not 70 deg C or higher within 20 sec .
- 0010 the power has been turned off and then on without resetting the error in question.

#### E001 (abnormal rise in temperature)

- 0001 the main thermistor or the sub thermistor has been identified as being faulty, or an open circuit has been detected.
- 0002 the reading of the main thermistor or that of the sub thermistor is 230 deg C or higher for 2 sec.
- 0003 the reading is not 150 deg C or higher or 210 deg C or lower within 30 sec (at time of a remedial job).
- 0010 the power has been turned off and then on without resetting of the error in question.

#### E002 (faulty rise in temperature)

- 0000 the reading of the main thermistor is in excess of 70 deg C and, thereafter, it does not reach 150 deg C within 12 sec.
- 0001 the reading of the main thermistor is in excess of 100 deg C and, thereafter, it does not reach 150 deg C within 15 sec.
- 0010 the power has been turned off and then on without resetting of the error in question.

#### E003 (faulty rise in temperature)

- 0000 the reading of the main thermistor is in excess of 100 deg C and, thereafter, is lower than 70 deg C for 2 sec or more.

0010 the power has been turned off and then on without resetting of the error in question.

**E004 (fixing heater power supply error (IH power supply))**

0101 there is a mismatch between the input voltage and the IH power supply ID.

0102 the fault IH current is faulty (current leakage).

0103 the IH current is faulty (absence of current).

0104 there is overcurrent.

0201 when the power is turned on (or while the IH drive is suspended), the IH control mechanisms is not in an initial state.

0202 at time of IH start-up, the IH control enable flag is not set within 1 sec after the start flag has been set.

0203 when IH is stored, the IH control ongoing flag is not released within 1 sec.

0204 the 12-V power supply (IH relay) is identified as being OFF.

0205 at IH start-up, the PWM ON signal data has an error.

---

---



If E000 through E004 is indicated, the error code will not be reset even when you turn off the main power switch, requiring you to use service mode (COPIER > FUNCTION > CLEAR > ERR).

---

## 9.5 Parts Replacement Procedure

### 9.5.1 Fixing/Feeding Assembly

#### 9.5.1.1 Before Removing the Fixing/Feeding unit

iR5065 / iR 5055 / iR5075 / iR5075N / iR5065N / iR5055N

- 1) Detach the duplexing feed front cover. (page 10-14) Reference [Removing the Duplexing Feed Front Cover]

#### 9.5.1.2 Removing the Fixing/Feeding unit

iR5065 / iR 5055 / iR5075 / iR5075N / iR5065N / iR5055N

- 1) While pushing the hook shaft [1] found at the rear of the fixing/feeding unit in the direction of the arrow (toward the machine front), rotate the fixing/feeding unit release lever clockwise to lock it in place [2].

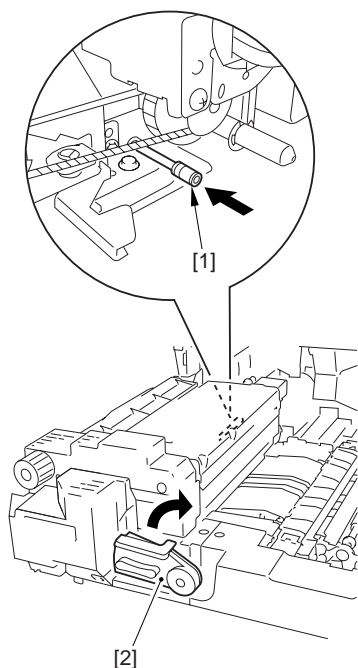

F-9-28

- 2) While pushing the 2 stopper plates [1] of the rail assembly of the fixing/feeding unit to the inside and slide out the fixing/feeding unit [2].

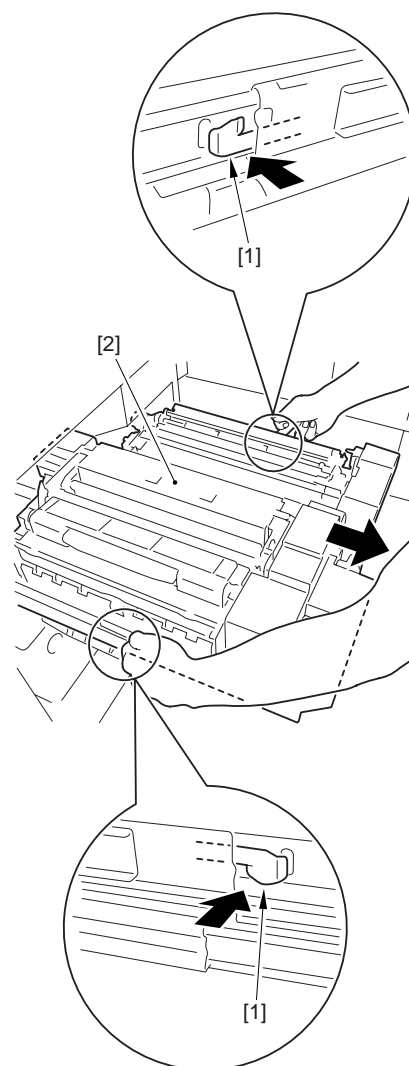

F-9-29



Follow the steps above when sliding out the fixing/feeding unit. Follow the steps below when detaching the fixing/feeding unit from the machine.

- 3) Remove the fixing/feeding unit [2] from the rail.  
- 2 screws [1]

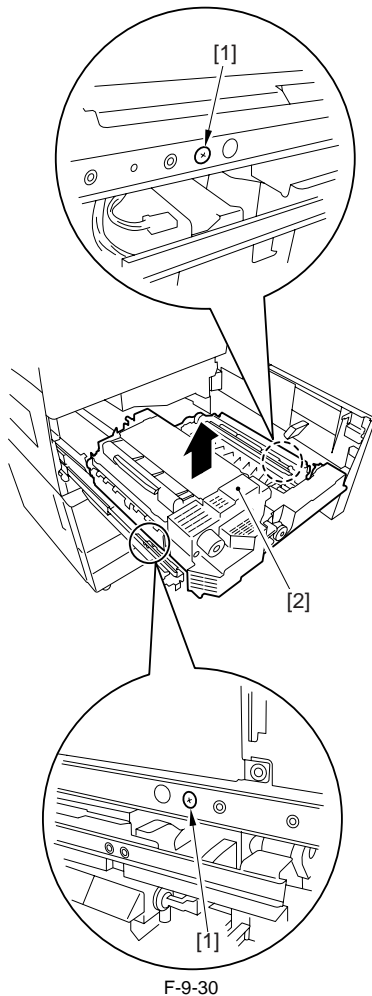

F-9-30

## 9.5.2 Fixing Unit

### 9.5.2.1 Before Removing the Fixing Upper Unit

iR5065 / iR 5055 / iR5075 / iR5075N / iR5065N / iR5055N

- 1) Detach the duplexing feed front cover. (page 10-14) Reference[Removing the Duplexing Feed Front Cover]
- 2) Slide out the fixing/feeding unit. (page 9-19) Reference[Removing the Fixing/Feeding unit]
- 3) Detach the fixing front cover. (page 10-16) Reference[Removing the Fixing Front Cover]
- 4) Detach the fixing/feeding unit front cover. (page 10-15) Reference[Removing the Fixing/Feeding Unit Front Cover]
- 5) Detach the fixing/feeding unit middle cover. (page 10-15) Reference[Removing the Fixing/Feeding Unit Middle Cover]
- 6) Detach the fixing upper cover. (page 10-15) Reference[Removing the Fixing Upper Cover]
- 7) Remove the fixing drive assembly. (page 10-22) Reference[Removing the Fixing Drive Assembly]

### 9.5.2.2 Removing the Fixing Upper Unit

iR5065 / iR 5055 / iR5075 / iR5075N / iR5065N / iR5055N

- 1) Release the 3 harness guide locks [1] to free the harness from the guides and disconnect 6 connectors [2].

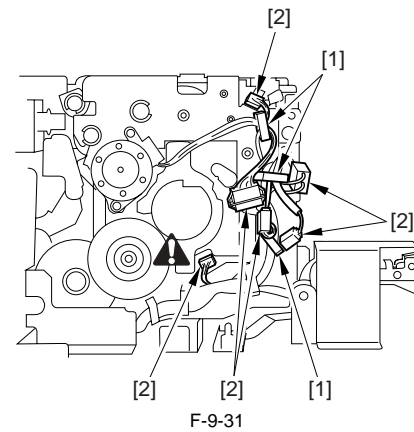

F-9-31



Be sure to disconnect the shutter HP sensor connector. If left connected when removing the fixing upper unit, the shutter mount plate may be deformed or the connector may be damaged.

- 2) Remove the fixing upper unit [2] in the direction of the arrow.  
- 2 screws [1]

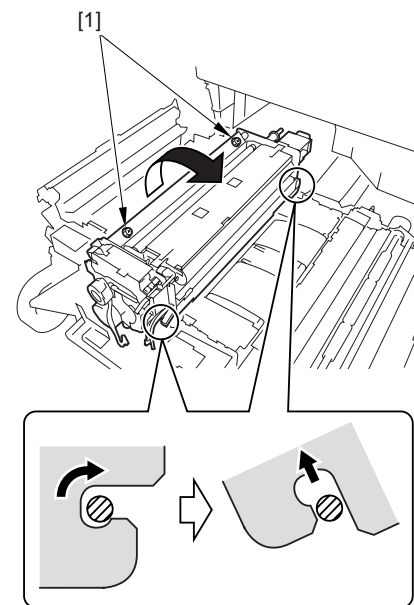

F-9-32

## 9.5.3 Pressure Roller

### 9.5.3.1 Before Removing the Pressure Roller

iR5065 / iR 5055 / iR5075 / iR5075N / iR5065N / iR5055N

- 1) Detach the duplexing feed front cover. (page 10-14) Reference[Removing the Duplexing Feed Front Cover]
- 2) Slide out the fixing/feeding unit. (page 9-19) Reference[Removing the Fixing/Feeding unit]
- 3) Detach the fixing front cover. (page 10-16) Reference[Removing the Fixing Front Cover]
- 4) Detach the fixing/feeding unit front cover. (page 10-15) Reference[Removing the Fixing/Feeding Unit Front Cover]
- 5) Detach the fixing/feeding unit middle cover. (page 10-15) Reference[Removing the Fixing/Feeding Unit Middle Cover]
- 6) Detach the fixing upper cover. (page 10-15) Reference[Removing the Fixing Upper Cover]
- 7) Remove the fixing drive assembly. (page 10-22) Reference[Removing the Fixing Drive Assembly]
- 8) Remove the fixing upper unit. (page 9-20) Reference[Removing the Fixing Upper Unit]
- 9) Remove the lower separation claw unit. (page 9-39) Reference[Removing the Lower Separation Claw (Unit)]

### 9.5.3.2 Removing the Pressure Roller

iR5065 / iR 5055 / iR5075 / iR5075N / iR5065N / iR5055N

- 1) Remove the pressure roller assembly [1]. Place the removed pressure roller assembly temporarily on the paper.

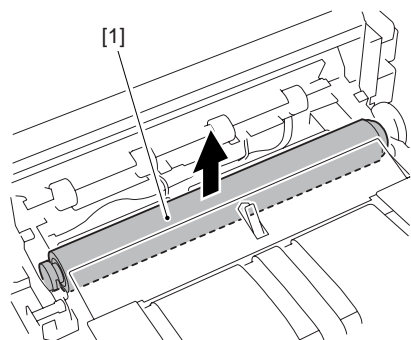

F-9-33

- 2) Remove the pressure roller assembly.
  - 2 E-rings at the both end [1]
  - 2 bearings [2]

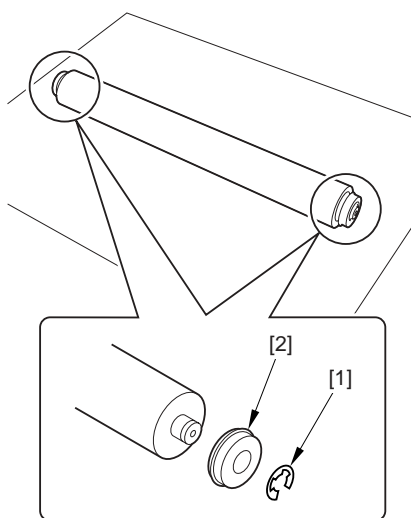

F-9-34



As aged, the rubber surface of the pressure roller may be discolored by heat. This change, however, will not affect its performance or output images. Further, the physical properties of the roller may develop wrinkles on the roller surface. The wrinkles will be smoothed under heat and not affect the performance, so that the replacement is not required.

## 9.5.4 Upper Fixing Roller

### 9.5.4.1 Before Removing the Fixing Roller

iR5065 / iR 5055 / iR5075 / iR5075N / iR5065N / iR5055N

- 1) Detach the duplexing feed front cover. (page 10-14)Reference[Removing the Duplexing Feed Front Cover]
- 2) Slide out the fixing/feeding unit. (page 9-19)Reference[Removing the Fixing/Feeding unit]
- 3) Detach the fixing front cover. (page 10-16)Reference[Removing the Fixing Front Cover]
- 4) Detach the fixing/feeding unit front cover. (page 10-15)Reference[Removing the Fixing/Feeding Unit Front Cover]
- 5) Detach the fixing/feeding unit middle cover. (page 10-15)Reference[Removing the Fixing/Feeding Unit Middle Cover]
- 6) Detach the fixing upper cover. (page 10-15)Reference[Removing the Fixing Upper Cover]
- 7) Remove the fixing drive assembly. (page 10-22)Reference[Removing the Fixing Drive Assembly]
- 8) Remove the fixing upper unit. (page 9-20)Reference[Removing the Fixing Upper Unit]
- 9) Remove the fixing web. (page 9-32)Reference[Removing the Fixing Web]

### 9.5.4.2 Removing the Fixing Roller

iR5065 / iR 5055 / iR5075 / iR5075N / iR5065N / iR5055N

- 1) Remove 1 screw [1] and the pin [2]. The screw and pin removed here will be used in the step 6).

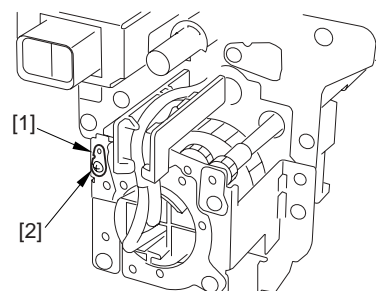

F-9-35

- 2) Rotate the shutter drive gear [1] by finger so that the shutter gear [2] rotates until the cut-off [3] of the shutter gear matches the hole in the plate [4].

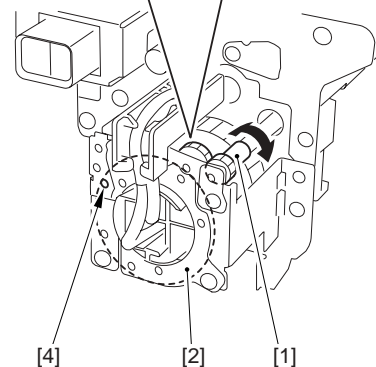
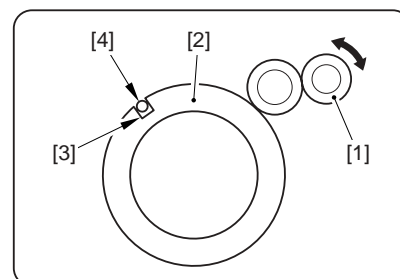

F-9-36

- 3) Fit the pin removed in the step 1) into the hole [2], then fix with 1 screw [3] in place.

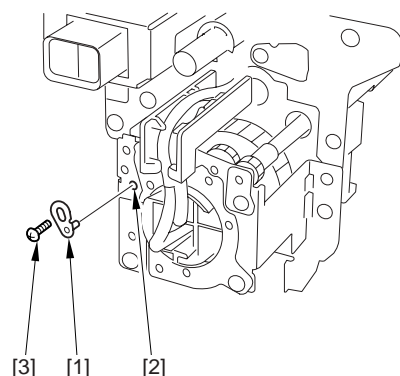

F-9-37



The pin should be fit back in the initial position after completing the foregoing steps and before mounting the fixing upper unit on the machine.

- 4) Remove 2 screws [2] that fix the AC connector support plate [1].

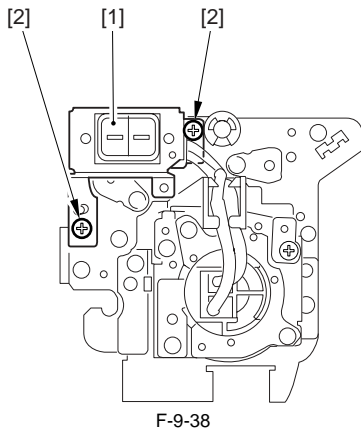

F-9-38

- 5) Turn the fixing upper unit upside down.
- 6) Remove the shutter drive gear shaft support plate [2].  
- 1 screw [1]

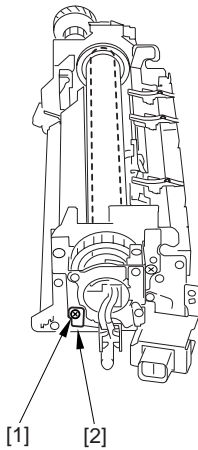

F-9-39

- 7) Slide out the heater unit [2] to remove.  
- 2 screws [1]

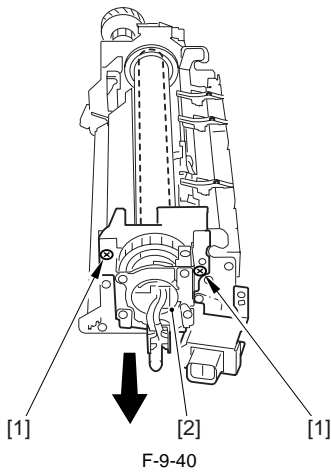

F-9-40

- 8) Remove the core positioning plate (front) [2].  
- 2 screws [1]

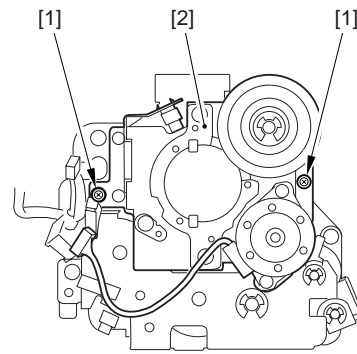

F-9-41

- 9) Remove 1 screw [1] and the pin [2]. The screw and pin removed here will be used in the step 11).

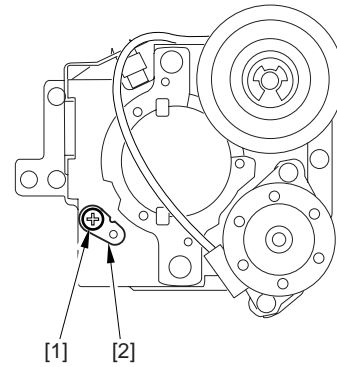

F-9-42

- 10) Rotate the shutter drive gear [1] by finger so that the cut-off [2] of the shutter gear matches to the hole in the plate [3].

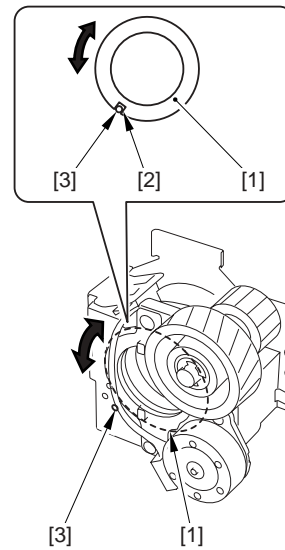

F-9-43

- 11) Fit the pin [1] removed in the step 9) in the hole [2], then fix with 1 screw [3] in place.



- The shutter is thin (0.5mm in thickness) and can be easily deformed. Once deformed, it may damage the roller surface by interference. Cares must be taken not to deform the shutter during the work.  
- As aged, the shutter surface may be discolored by heat or damaged due to friction. This, however, will not affect the performance.

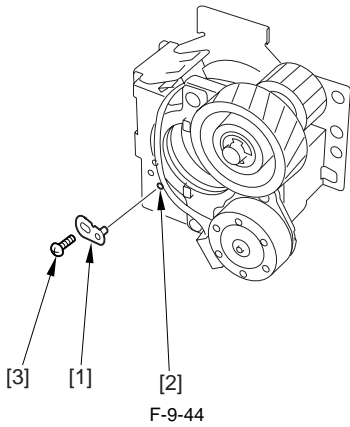

F-9-44



The pin should be fit back in the initial position after completing the foregoing steps and before mounting the fixing upper unit on the machine.

- 12) Release 2 hooks [1] that fix the bearings at the both end of the fixing roller to remove the fixing roller assembly [2].

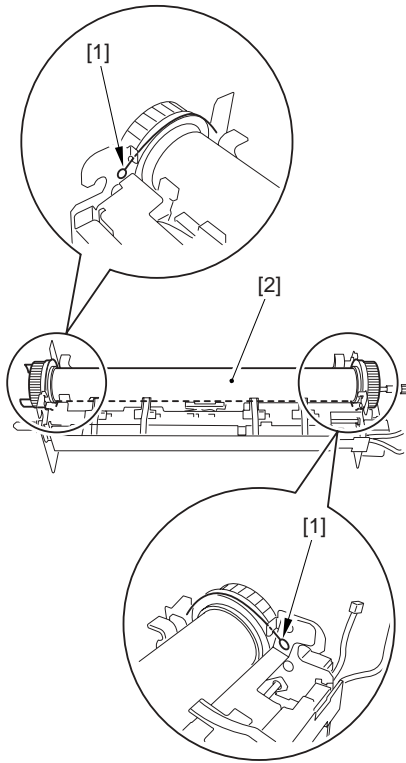

F-9-45



- When replacing gear/bushing/bearing only (that is, the fixing roller not to be replaced), wrap paper around the roller before starting the replacement. This is to prevent any possible damage to the roller surface in such event that the bearing is fallen on it during the work.
- The removed roller should be placed on paper temporarily during the work.

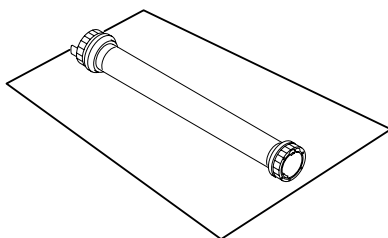

F-9-46

- 13) Remove 2 C-rings [1], 2 gears [2], 2 bushings [3] and 2 bearings from the fixing roller assembly.

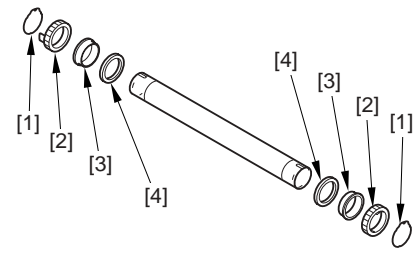

F-9-47



As aged, the fixing roller surface may be discolored by heat. This, however, will not affect the performance. The fixing roller surface color is different depending on the vendors but any rollers meet the specified performance.

### 9.5.4.3 Points to Note When Mounting the Fixing Roller

iR5065 / iR 5055 / iR5075 / iR5075N / iR5065N / iR5055N

- A new fixing roller is wrapped in paper. The paper should not be removed until the fixing roller is placed in the specified position in the fixing upper unit and the bearings at the both ends are fixed with hooks. This is to prevent any possible damage to the roller surface in such event that the bearing is fallen on the fixing roller.
- Pay attention to the orientation of the bearings [1] and the bushings [2]. Be sure that the grooved side of bearing faces inside and the collar of the bushing faces outside. Also the rear and front fixing gears shape differently; mount the gear [3] (w/ larger protrusion) rear and the gear [4] (w/ smaller protrusion) front.

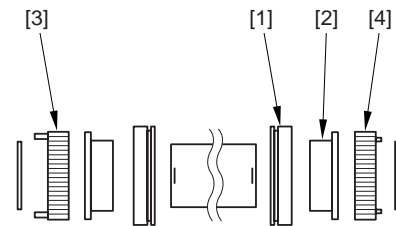

F-9-48

- When fixing the C-ring [1], be sure to hook the 2 ends of the C-ring [1] on the protruded parts of the fitting gear and fit the 3 protrusions of the C-ring [2] properly into the grooves on the fixing roller.

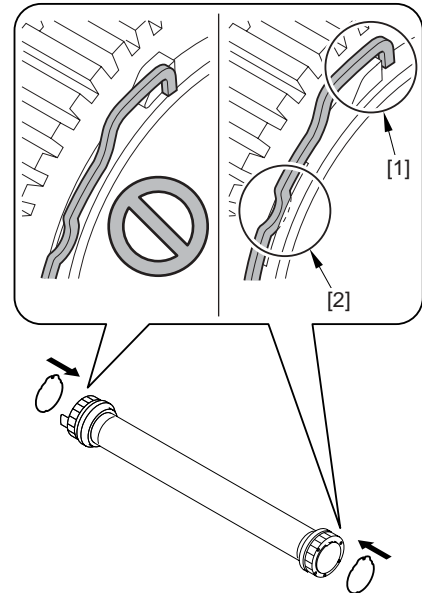

F-9-49

- When mounting the fixing roller, care should be taken not to hit the thermal switch with the fixing roller.
- After mounting the fixing roller, make sure that the main thermistor [1], the shutter thermistor [2] and the sub thermistor [3] are parallel and contact with the fixing roller.

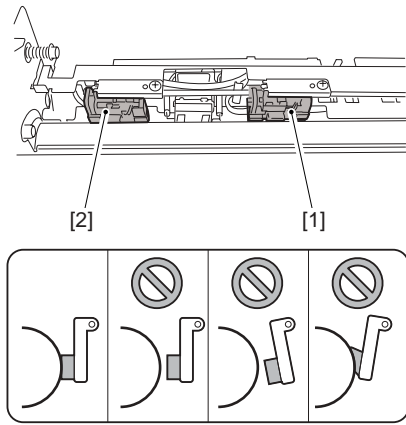

F-9-50

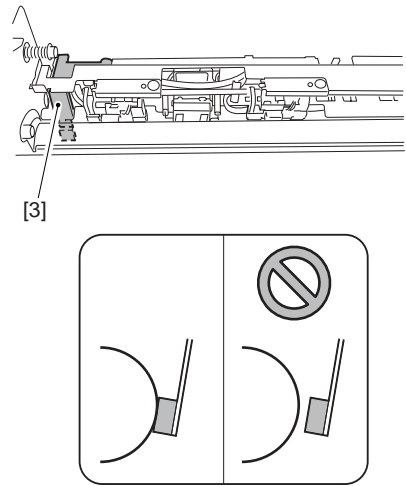

F-9-51

- When fixing the core positioning plate [1] (both front and rear sides) with screws [2] after mounting the fixing roller, tighten the screws while pushing the bearing [3] of the fixing roller downward with finger. This is to eliminate the gap [A] between the bearing and the fixing frame. This work should be properly done, or the gap in the joint is likely to cause the fixing fault or paper wrinkles.

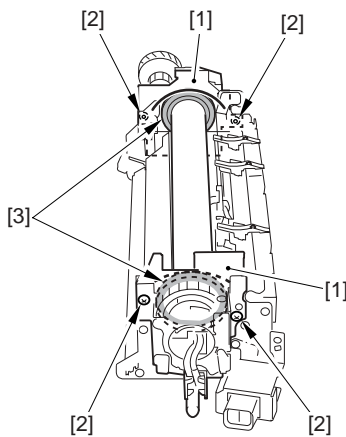

F-9-52

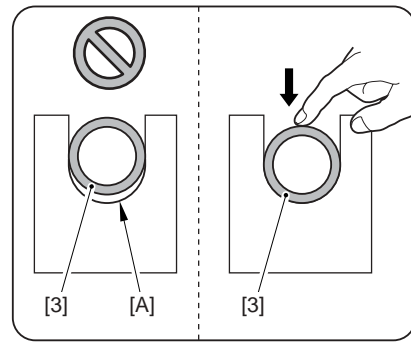

F-9-53

- Be sure to remove the paper around the roller after mounting the fixing roller to the fixing unit.  
 - Be sure to fit the 2 pins [1] back to the initial positions. If this is undone when turning the main power switch on, 'E840' error will be returned. If turning on the main power switch with the only one pin fit, this will cause not only the 'E840' error but also the shutter distortion.

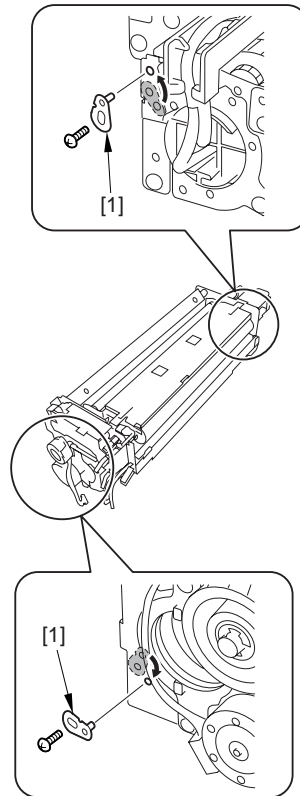

F-9-54

#### 9.5.4.4 Applying Grease After Replacing the Fixing Roller

iR5065 / iR 5055 / iR5075 / iR5075N / iR5065N / iR5055N

- About 20mg of grease (Molykote HP-300; CK-8012) should be applied to the inner [1] and the outer surfaces [2] of the bushing until the white coat covering is formed uniformly. If this undone, the noise (squeaking) may occur.



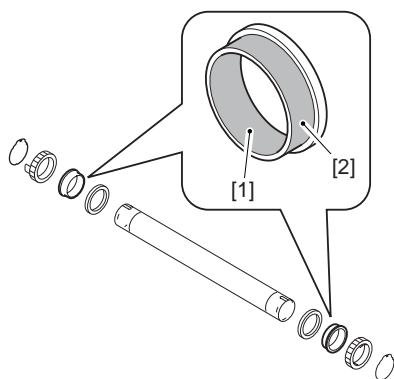

F-9-55

- Applied grease may be transferred from the bushing to the fixing roller ends [1] when mounting; be sure to wipe it off when this happens.

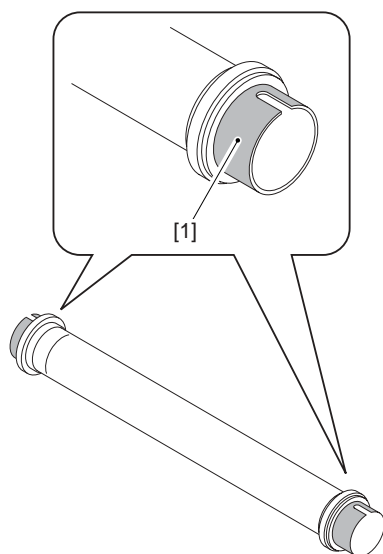

F-9-56

#### 9.5.4.5 Adjusting the Nip Width

iR5065 / iR 5055 / iR5075 / iR5075N / iR5065N / iR5055N

The nip width adjustment is not necessary.

#### 9.5.5 External Delivery Roller

##### 9.5.5.1 Before Removing the External Delivery Roller

iR5065 / iR 5055 / iR5075 / iR5075N / iR5065N / iR5055N

- 1) Detach the duplexing feed front cover. (page 10-14) Reference [Removing the Duplexing Feed Front Cover]
- 2) Detach the fixing/feeding unit. (page 9-19) Reference [Removing the Fixing/Feeding unit]

##### 9.5.5.2 Removing the External Delivery Roller

iR5065 / iR 5055 / iR5075 / iR5075N / iR5065N / iR5055N

- 1) Remove the delivery roller guide [2].
  - 2 screws [1]

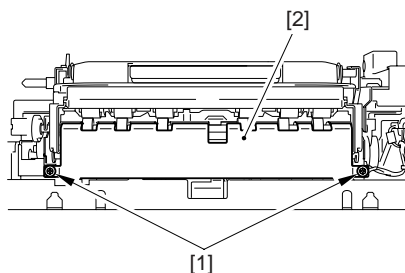

F-9-57

- 2) Remove the bushing [2] and the delivery unit [3].
  - 1 screw [1]

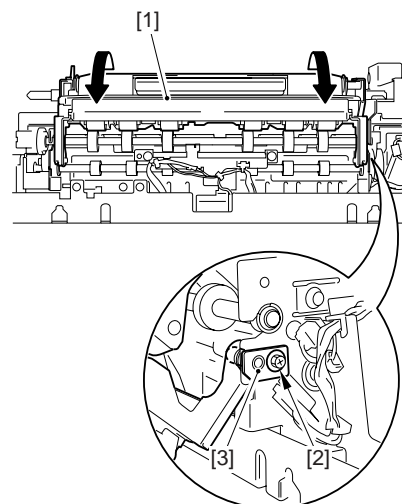

F-9-58



When putting the removed delivery unit aside temporarily, place the unit to the orientation as shown in the figure below. The separation claw may be damaged if the claw hit against the floor.

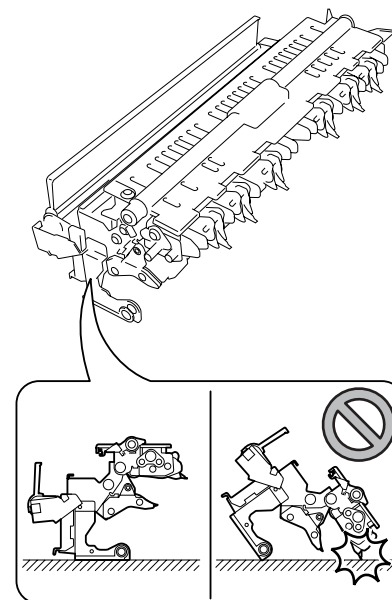

F-9-59

- 3) Remove the external delivery roller [9].

- 1 E-ring [1]
- 1 O-ring [4]
- 1 bushing [3] (at the front)
- 1 E-ring [4]
- 1 gear [5]
- 1 E-ring [6]
- 1 O-ring [7]
- 1 bushing [8] (at the rear)

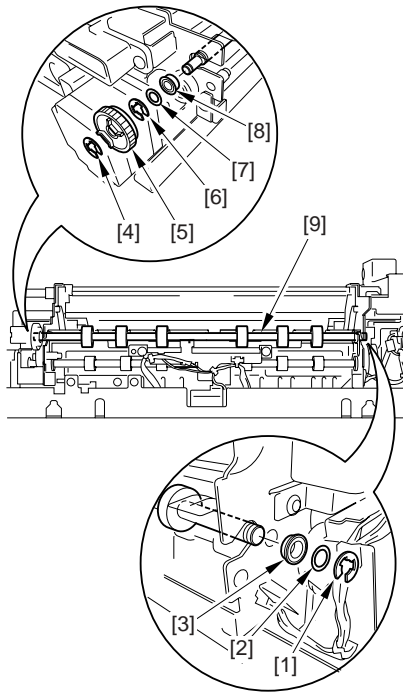

F-9-60

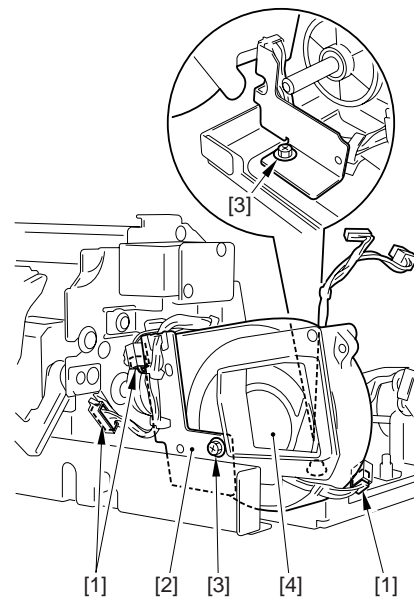

F-9-61

- 2) Shift the gear [2].  
- 1 E-ring [1]

### 9.5.6 Internal Delivery Roller

#### 9.5.6.1 Before Removing the Internal Delivery Roller

iR5065 / iR 5055 / iR5075 / iR5075N / iR5065N / iR5055N

- 1) Detach the duplexing feed front cover. (page 10-14)Reference[Removing the Duplexing Feed Front Cover]
- 2) Detach the fixing/feeding unit. (page 9-19)Reference[Removing the Fixing/Feeding unit]
- 3) Detach the fixing front cover. (page 10-16)Reference[Removing the Fixing Front Cover]
- 4) Detach the fixing/feeding unit front cover. (page 10-15)Reference[Removing the Fixing/Feeding Unit Front Cover]
- 5) Detach the fixing/feeding unit middle cover. (page 10-15)Reference[Removing the Fixing/Feeding Unit Middle Cover]
- 6) Detach the fixing upper cover. (page 10-15)Reference[Removing the Fixing Upper Cover]
- 7) Remove the fixing drive assembly. (page 10-22)Reference[Removing the Fixing Drive Assembly]
- 8) Remove the fixing upper unit. (page 9-20)Reference[Removing the Fixing Upper Unit]
- 9) Remove the lower separation claw unit. (page 9-39)Reference[Removing the Lower Separation Claw (Unit)]

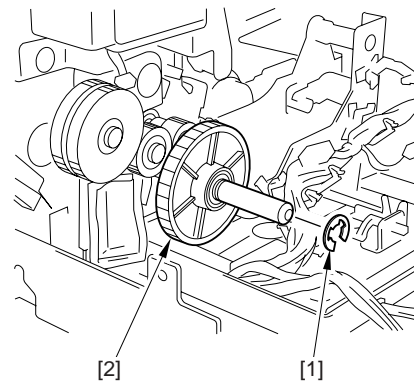

F-9-62

- 3) Remove the gear [2].  
- 1 E-ring [1]

#### 9.5.6.2 Removing the Internal Delivery Roller

iR5065 / iR 5055 / iR5075 / iR5075N / iR5065N / iR5055N

- 1) Slide the fixing heat discharge fan assembly [3] toward the outside.  
- 3 connectors [1]  
- 3 screws [2]

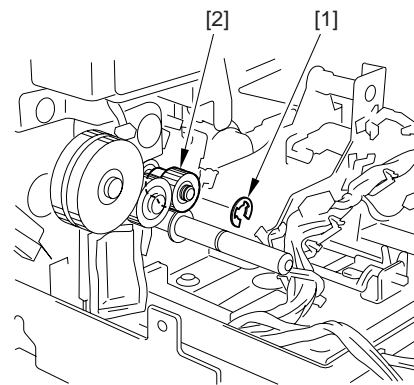

F-9-63

The following steps 4) and 5) are performed at the rear side.

- 4) Remove 1 connector [3] found inside of the delivery motor [2].  
- 4 screws [1]



Be careful not the bearing and the O-ring fallen off.

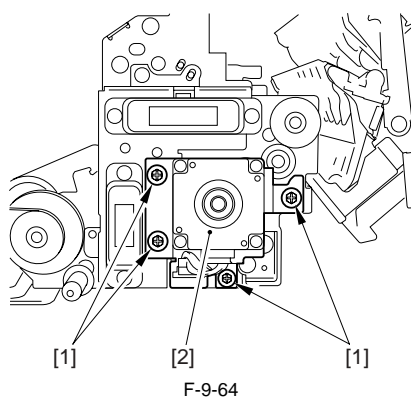

F-9-64

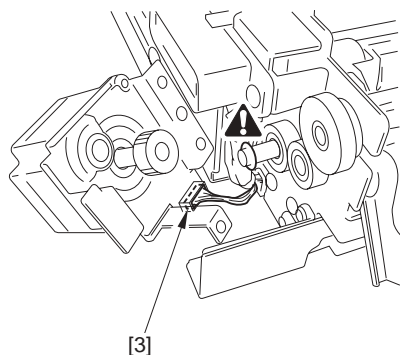

F-9-65

- 5) Shift the connector support plate [2] toward the outside.  
- 2 screws [1]

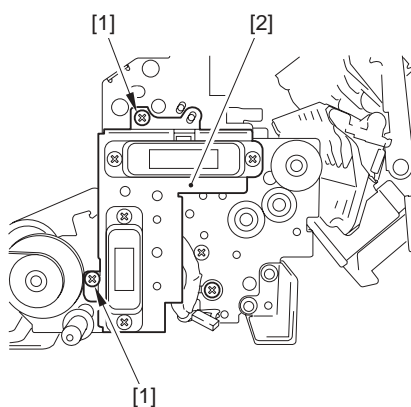

F-9-66

- 6) Remove the internal delivery roller [3].  
- 2 E-rings [1]  
- 2 bearings [2]

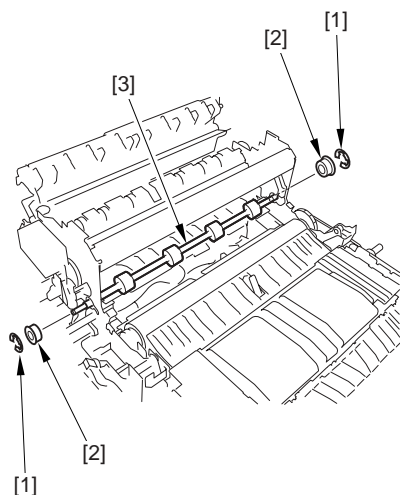

F-9-67

### 9.5.6.3 Points to Note When Mounting the Internal Delivery Roller

iR5065 / iR 5055 / iR5075 / iR5075N / iR5065N / iR5055N

A harness is found near the end of the internal delivery roller shaft (at the rear side) and 2 plastic sheets [1] are attached to protect the harness. When mounting/removing the internal delivery roller, be careful not to remove these plastic sheets by accident. If removed accidentally, reattach the sheets back to the initial positions.

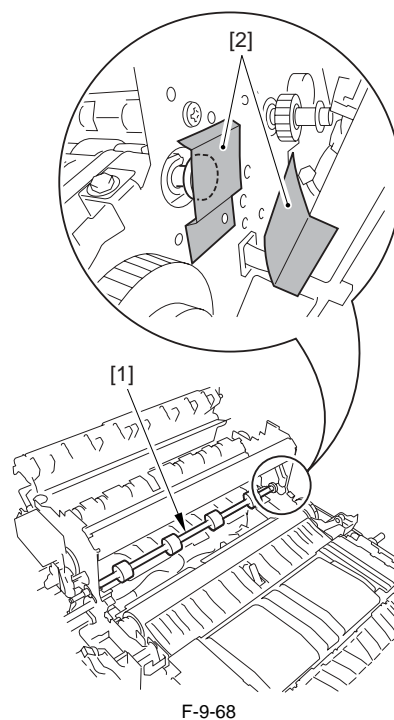

F-9-68

### 9.5.7 Main Thermistor

#### 9.5.7.1 Before Removing the Main Thermistor/Shutter Thermistor

iR5065 / iR 5055 / iR5075 / iR5075N / iR5065N / iR5055N

- 1) Detach the duplexing feed front cover. ([page 10-14](#))Reference[Removing the Duplexing Feed Front Cover]
- 2) Slide out the fixing/feeding unit. ([page 9-19](#))Reference[Removing the Fixing/Feeding unit]
- 3) Detach the fixing front cover. ([page 10-16](#))Reference[Removing the Fixing Front Cover]
- 4) Detach the fixing/feeding unit front cover. ([page 10-15](#))Reference[Removing the Fixing/Feeding Unit Front Cover]
- 5) Detach the fixing/feeding unit middle cover. ([page 10-15](#))Reference[Removing the Fixing/Feeding Unit Middle Cover]
- 6) Detach the fixing upper cover. ([page 10-15](#))Reference[Removing the Fixing Upper Cover]
- 7) Remove the fixing drive assembly. ([page 10-22](#))Reference[Removing the Fixing Drive Assembly]
- 8) Remove the fixing upper unit. ([page 9-20](#))Reference[Removing the Fixing Upper Unit]
- 9) Remove the fixing web. ([page 9-32](#))Reference[Removing the Fixing Web]

#### 9.5.7.2 Removing the Main Thermistor/Shutter Thermistor

iR5065 / iR 5055 / iR5075 / iR5075N / iR5065N / iR5055N

- 1) Remove the bushing [2], and then remove the web unit [3].  
- 1 screw [1]

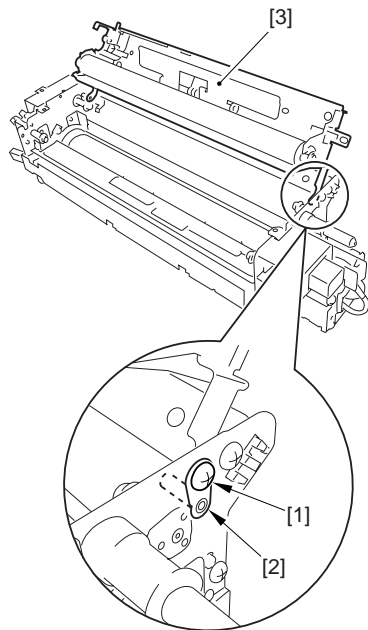

F-9-69

- 2) Remove the silicone oil tray [2].  
- 1 screw [1]

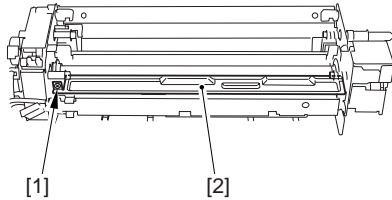

F-9-70

- 3) Detach the harness retaining cover [2].  
- 1 screw [1]

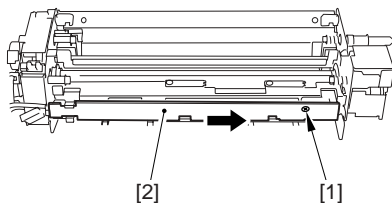

F-9-71

- 4) Free the harness from the harness guide assembly [1].

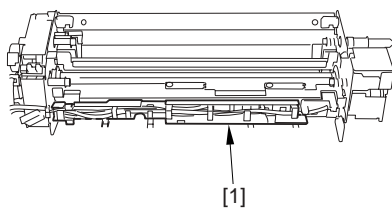

F-9-72

- 5) Shift the thermistor mounting shaft [2] to detach it from the bushing.  
- 2 screws [1]  
- 1 reuse band [3]

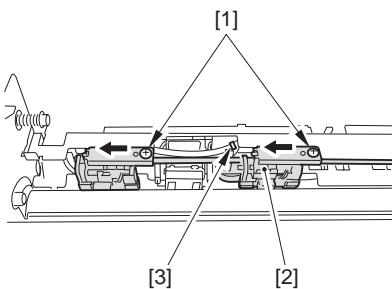

F-9-73

- 6) Remove the 2 leaf springs each [1] to remove the main thermistor [2] and the shutter thermistor [3].

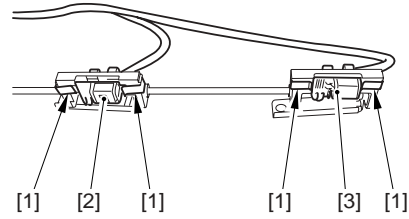

F-9-74

### 9.5.7.3 Points to Note When Mounting the Main Thermistor/Shutter Thermistor

iR5065 / iR 5055 / iR5075 / iR5075N / iR5065N / iR5055N

- Route the harness of the thermistor as shown below. The harness [1] should route via the outside (the rear side) of the guide pin [2].

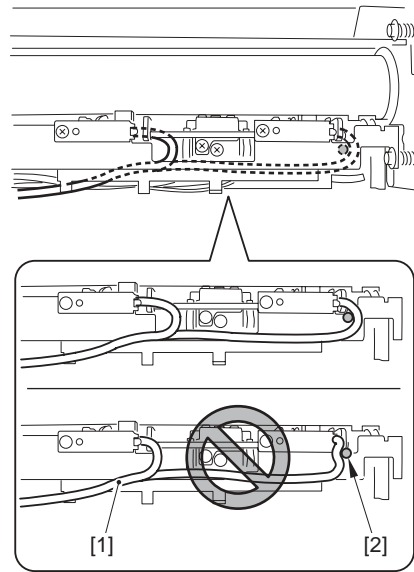

F-9-75

- After mounting, make sure the main thermistor [1] and the shutter thermistor [2] are parallel and contact with the fixing roller. If not, restart the mounting steps

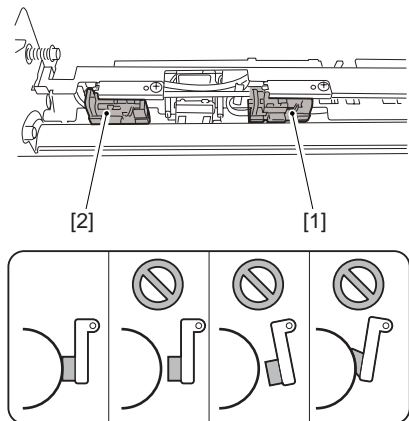

F-9-76

### 9.5.8 Sub Thermistor

#### 9.5.8.1 Before Removing the Sub Thermistor

iR5065 / iR 5055 / iR5075 / iR5075N / iR5065N / iR5055N

- 1) Detach the duplexing feed front cover. (page 10-14)Reference[Removing the Duplexing Feed Front Cover]
- 2) Slide out the fixing/feeding unit. (page 9-19)Reference[Removing the Fixing/Feeding unit]
- 3) Detach the fixing front cover. (page 10-16)Reference[Removing the Fixing Front Cover]
- 4) Detach the fixing/feeding unit front cover. (page 10-15)Reference[Re-

moving the Fixing/Feeding Unit Front Cover]

- 5) Detach the fixing/feeding unit middle cover. (page 10-15)Reference[Removing the Fixing/Feeding Unit Middle Cover]
- 6) Detach the fixing upper cover. (page 10-15)Reference[Removing the Fixing Upper Cover]
- 7) Remove the fixing drive assembly. (page 10-22)Reference[Removing the Fixing Drive Assembly]
- 8) Remove the fixing upper unit. (page 9-20)Reference[Removing the Fixing Upper Unit]
- 9) Remove the fixing web. (page 9-32)Reference[Removing the Fixing Web]

### 9.5.8.2 Removing the Sub Thermistor

iR5065 / iR 5055 / iR5075 / iR5075N / iR5065N / iR5055N

- 1) Remove the bushing [2], and then remove the web unit [3].  
- 1 screw [1]

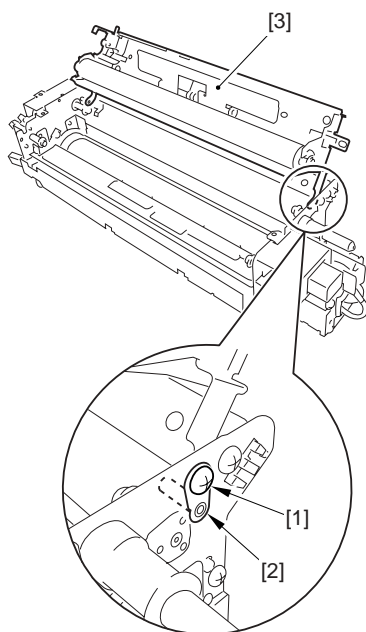

F-9-77

- 2) Remove the silicone oil tray [2].  
- 1 screw [1]

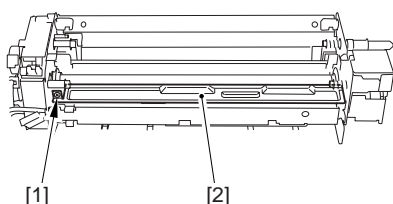

F-9-78

- 3) Detach the harness retaining cover [2].  
- 1 screw [1]

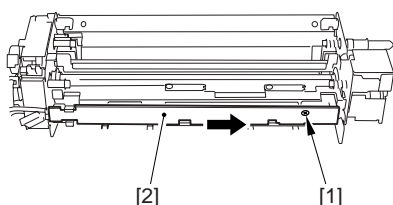

F-9-79

- 4) Free the harness from the harness guide assembly [1].

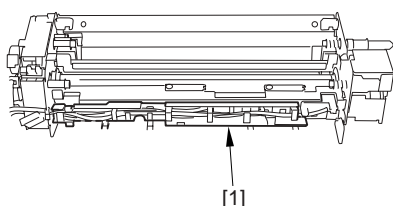

F-9-80

- 5) Remove the sub thermistor assembly [2].  
- 1 screw [1]

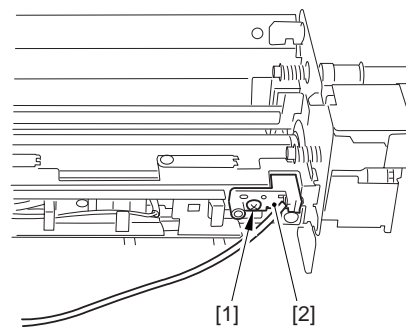

F-9-81

- 6) Remove the sub thermistor [2].  
- 1 screw [1]

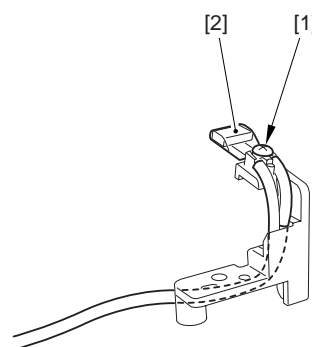

F-9-82

### 9.5.8.3 Points to Note When Mounting the Sub Thermistor

iR5065 / iR 5055 / iR5075 / iR5075N / iR5065N / iR5055N

- After mounting, make sure that the sub thermistor [1] is parallel and contacts with the fixing roller. If not, restart the mounting steps.

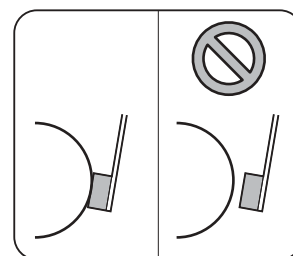
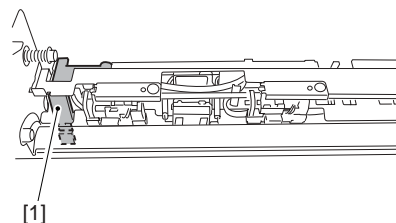

F-9-83

## 9.5.9 Thermal Switch

### 9.5.9.1 Before Removing the Thermal Switch

iR5065 / iR 5055 / iR5075 / iR5075N / iR5065N / iR5055N

- 1) Detach the duplexing feed front cover. (page 10-14)Reference[Removing the Duplexing Feed Front Cover]
- 2) Slide out the fixing/feeding unit. (page 9-19)Reference[Removing the Fixing/Feeding unit]
- 3) Detach the fixing front cover. (page 10-16)Reference[Removing the Fixing Front Cover]
- 4) Detach the fixing/feeding unit front cover. (page 10-15)Reference[Removing the Fixing/Feeding Unit Front Cover]
- 5) Detach the fixing/feeding unit middle cover. (page 10-15)Reference[Removing the Fixing/Feeding Unit Middle Cover]
- 6) Detach the fixing upper cover. (page 10-15)Reference[Removing the

Fixing Upper Cover]

- 7) Remove the fixing drive assembly. (page 10-22)Reference[Removing the Fixing Drive Assembly]
- 8) Remove the fixing upper unit. (page 9-20)Reference[Removing the Fixing Upper Unit]
- 9) Remove the main thermistor/shutter thermistor assembly. (page 9-27)Reference[Removing the Main Thermistor/Shutter Thermistor]

**9.5.9.2 Removing the Thermal Switch**

iR5065 / iR 5055 / iR5075 / iR5075N / iR5065N / iR5055N

- 1) Free the harness of the thermal switch from the harness guide.

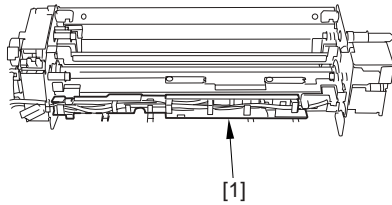

F-9-84

- 2) Remove the thermal switch [2]. (Remove the harness of the thermal switch [3] by leading it through the opening as shown in the figure below [A].)
- 1 screw [1]

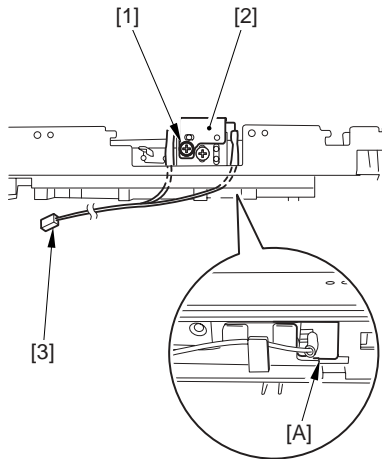

F-9-85

**9.5.10 Fixing Heater**

**9.5.10.1 Before Removing the Fixing Heater Unit**

iR5065 / iR 5055 / iR5075 / iR5075N / iR5065N / iR5055N

- 1) Detach the duplexing feed front cover. (page 10-14)Reference[Removing the Duplexing Feed Front Cover]
- 2) Slide out the fixing/feeding unit. (page 9-19)Reference[Removing the Fixing/Feeding unit]
- 3) Detach the fixing front cover. (page 10-16)Reference[Removing the Fixing Front Cover]
- 4) Detach the fixing/feeding unit front cover. (page 10-15)Reference[Removing the Fixing/Feeding Unit Front Cover]
- 5) Detach the fixing/feeding unit middle cover. (page 10-15)Reference[Removing the Fixing/Feeding Unit Middle Cover]
- 6) Detach the fixing upper cover. (page 10-15)Reference[Removing the Fixing Upper Cover]
- 7) Remove the fixing drive assembly. (page 10-22)Reference[Removing the Fixing Drive Assembly]
- 8) Remove the fixing upper unit. (page 9-20)Reference[Removing the Fixing Upper Unit]

**9.5.10.2 Removing the Fixing Heater Unit**

iR5065 / iR 5055 / iR5075 / iR5075N / iR5065N / iR5055N

- 1) Remove 1 screw [1] and the pin [2]. The screw and pin removed here will be used in the step 4) below.

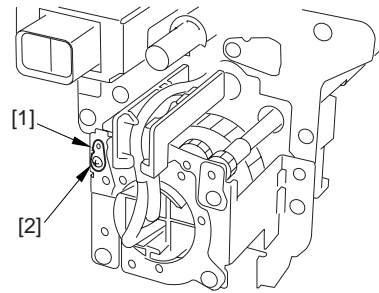

F-9-86

- 2) Rotate the shutter gear [2] by rotating the shutter drive gear [1] with finger until the cut-off of the shutter gear [3] matches to the hole in the plate [4].

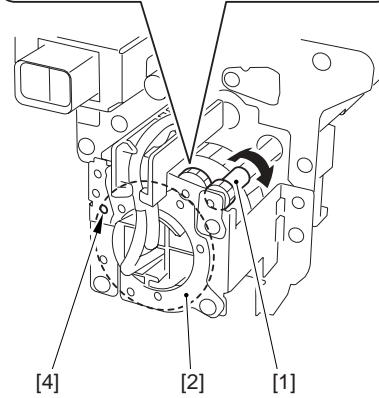
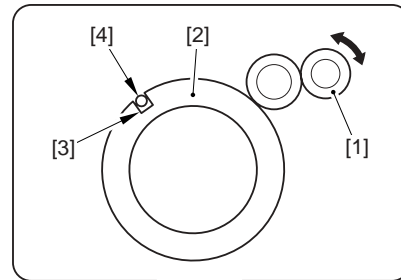

F-9-87

- 3) Fit the pin [1] (the one removed in the step 2)) in the hole [2] and fix it with the 1 screw [3].

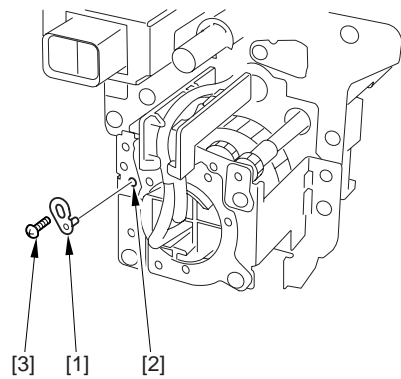

F-9-88

**!** After completing the works in these steps, fit the pin back to the initial position.

- 4) Remove the 2 screws [2] that fix the AC connector support plate [1].

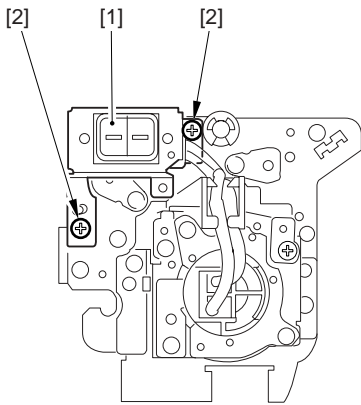

F-9-89

- 5) Turn the fixing upper unit upside down.
- 6) Remove the shutter drive gear shaft support plate [2].  
- 1 screw [1]

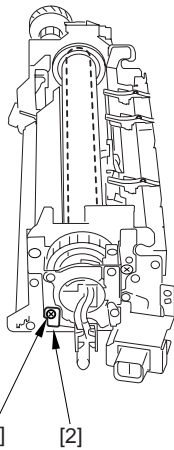

F-9-90

- 7) Slide out the heater unit [2] to detach.  
- 2 screws [1]

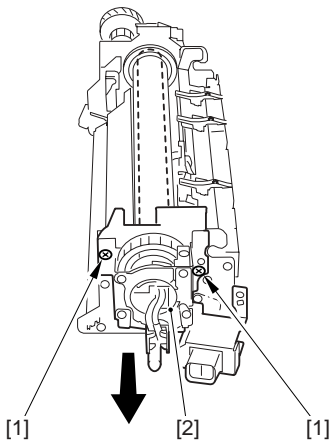

F-9-91

- 8) Free the AC harness [1] from the harness guide [2].

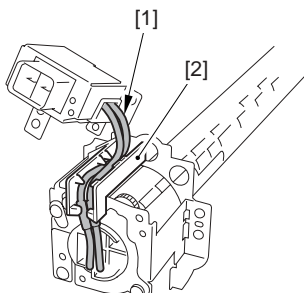

F-9-92

- 9) Remove the 2 screws [1] to free the AC harness from the clamp and re-

move the AC inlet [2].

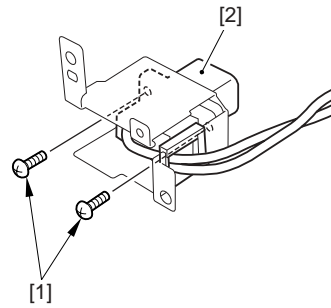

F-9-93

- 10) Remove the fixing heater unit stopper plate [2].  
- 1 screw [1]

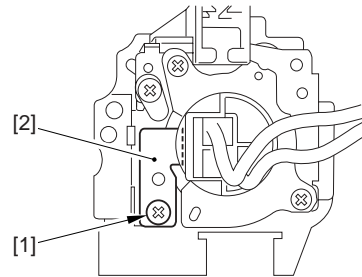

F-9-94



The 2 screws shown in the figure (glued in place) should not be loosened or removed.

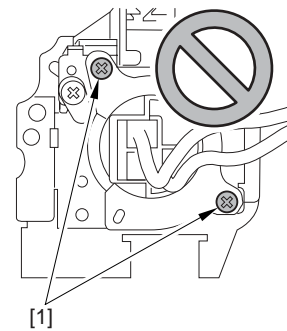

F-9-95

- 11) Remove the fixing heater unit [2] in the direction of the arrow.  
- the shutter [1]

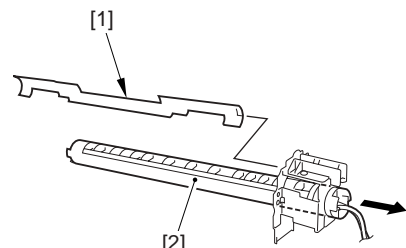

F-9-96



The shutter is thin (0.5mm in thickness) and may be easily deformed. Once deformed, the fixing roller surface can be damaged by interference. Cares should be taken during the work not to deform the shutter.

**MEMO:**

As aged, the shutter surface may be discolored by heat or damaged by friction, however, this will not affect the performance.

### 9.5.11 Fixing Cleaning Belt

#### 9.5.11.1 Before Removing the Fixing Web

iR5065 / iR 5055 / iR5075 / iR5075N / iR5065N / iR5055N

- 1) Detach the duplexing feed front cover. (page 10-14)Reference[Removing the Duplexing Feed Front Cover]
- 2) Slide out the fixing/feeding unit. (page 9-19)Reference[Removing the Fixing/Feeding unit]
- 3) Detach the fixing upper cover. (page 10-15)Reference[Removing the Fixing Upper Cover]

#### 9.5.11.2 Removing the Fixing Web

iR5065 / iR 5055 / iR5075 / iR5075N / iR5065N / iR5055N

- 1) Open the web unit [2].  
- 2 screws [1]

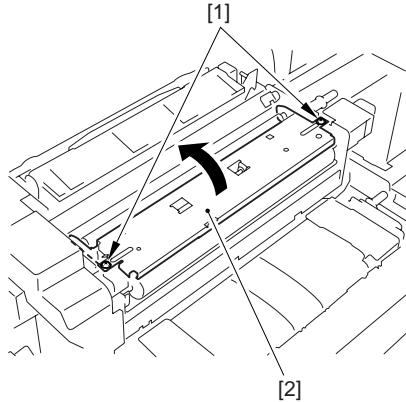

F-9-97

- 2) While pushing the web feed roller [1] and the web take-up roller [2] toward the rear side, detach the fixing web [3].

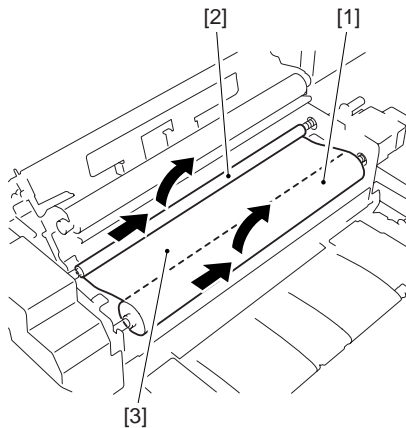

F-9-98

#### 9.5.11.3 Cleaning the fixing oil dish and the fixing cleaning belt guide

iR5065 / iR 5055 / iR5075 / iR5075N / iR5065N / iR5055N

- 1) Detach the fixing web.
- 2) Clean the surface of the silicone oil tray [1].
- 3) Clean the surface of the fixing cleaning web guide [2].

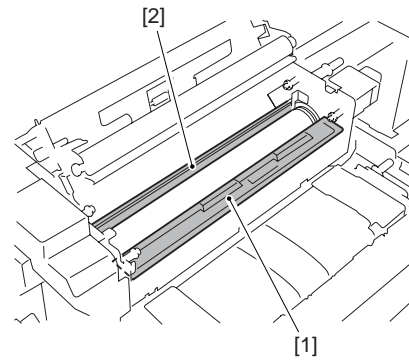

F-9-99

#### 9.5.11.4 Mounting the Fixing Web

iR5065 / iR 5055 / iR5075 / iR5075N / iR5065N / iR5055N

Reverse the removal steps above and follow them to mount the fixing web.

- 1) Wind the web [2] around the web take-up roller [1] for 2 to 3 times. Make sure the arm guide plate [3] facing the outside of the web take-up roller when mounting. Also make sure the oil impregnated in the contact area of the roller.

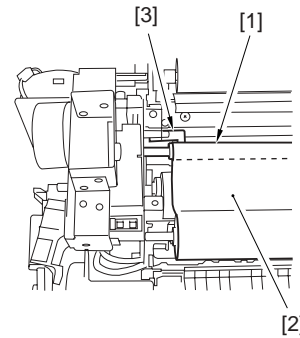

F-9-100



When winding the web, make sure the fixing web not skewed or free from slack [A] or wrinkles.

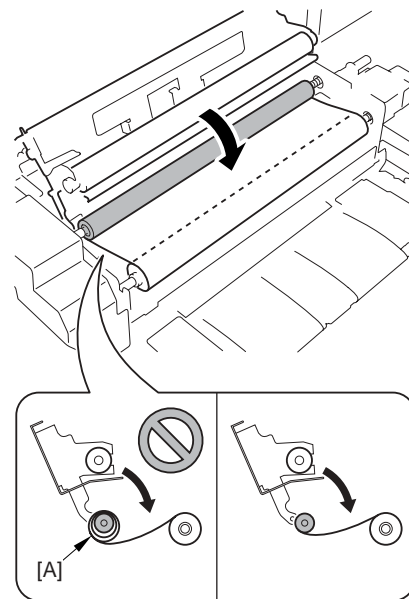

F-9-101

Follow the orientation shown in the figure below when winding and mounting the fixing web.



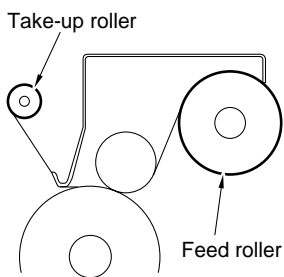

F-9-102

- 2) After fitting the fixing web, move the plunger [1] of the web guide solenoid in the direction of the arrow until the fixing web is free of the slack.

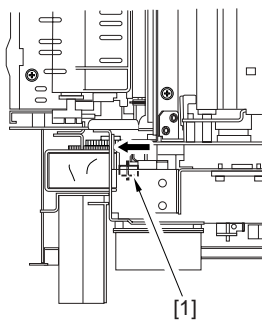

F-9-103

### 9.5.11.5 After Replacing the Fixing Web

iR5065 / iR 5055 / iR5075 / iR5075N / iR5065N / iR5055N

After replacing the fixing web, be sure to reset the counter reading to '0' by using the following service mode items.

**COPIER> COUNTER> MISC> FIX-WEB**  
**COPIER> COUNTER> DRBL-1> FX-WEB**

### 9.5.12 Fixing Jam Sensor

#### 9.5.12.1 Before Removing the Delivery Jam Sensor

iR5065 / iR 5055 / iR5075 / iR5075N / iR5065N / iR5055N

- 1) Detach the duplexing feed front cover. (page 10-14)Reference[Removing the Duplexing Feed Front Cover]
- 2) Detach the fixing/feeding unit. (page 9-19)Reference[Removing the Fixing/Feeding unit]
- 3) Remove the external delivery roller. (page 9-25)Reference[Removing the External Delivery Roller]

#### 9.5.12.2 Removing the Delivery Jam Sensor

iR5065 / iR 5055 / iR5075 / iR5075N / iR5065N / iR5055N

- 1) Slide out the sensor support plate.  
- 2 screws [1]

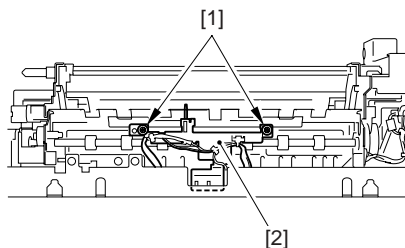

F-9-104

- 2) Remove the delivery jam sensor [2] from the sensor support plate.  
- 1 connector [1]

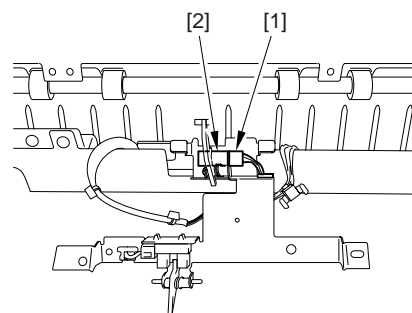

F-9-105

### 9.5.13 Claw Jam Sensor

#### 9.5.13.1 Before Removing the Claw Jam Sensor

iR5065 / iR 5055 / iR5075 / iR5075N / iR5065N / iR5055N

- 1) Detach the duplexing feed front cover. (page 10-14)Reference[Removing the Duplexing Feed Front Cover]
- 2) Slide out the fixing/feeding unit. (page 9-19)Reference[Removing the Fixing/Feeding unit]
- 3) Detach the fixing front cover. (page 10-16)Reference[Removing the Fixing Front Cover]
- 4) Detach the fixing/feeding unit front cover. (page 10-15)Reference[Removing the Fixing/Feeding Unit Front Cover]
- 5) Detach the fixing/feeding unit middle cover. (page 10-15)Reference[Removing the Fixing/Feeding Unit Middle Cover]
- 6) Detach the fixing upper cover. (page 10-15)Reference[Removing the Fixing Upper Cover]
- 7) Remove the fixing drive assembly. (page 10-22)Reference[Removing the Fixing Drive Assembly]
- 8) Remove the fixing upper unit. (page 9-20)Reference[Removing the Fixing Upper Unit]
- 9) Remove the lower separation claw unit. (page 9-39)Reference[Removing the Lower Separation Claw (Unit)]
- 10) Remove the internal delivery roller. (page 9-26)Reference[Removing the Internal Delivery Roller]

#### 9.5.13.2 Removing the Claw Jam Sensor

iR5065 / iR 5055 / iR5075 / iR5075N / iR5065N / iR5055N

- 1) Remove the protrusion [2] to slide out the sensor support plate [3].  
- 1 screw [1]

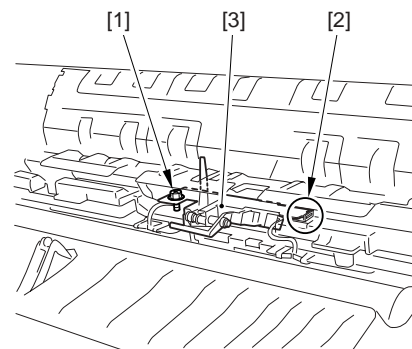

F-9-106

- 2) Remove the claw jam sensor [2] from the sensor support plate.  
- 1 connector [1]

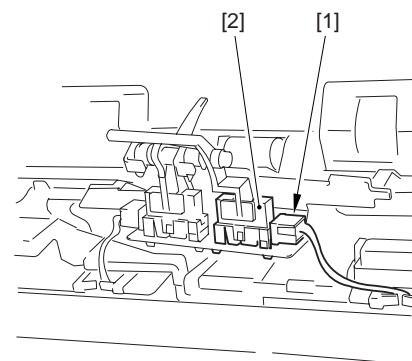

F-9-107

### 9.5.14 External Delivery Sensor

#### 9.5.14.1 Before Removing the External Delivery Sensor

iR5065 / iR 5055 / iR5075 / iR5075N / iR5065N / iR5055N

- 1) Detach the duplexing feed front cover. (page 10-14) Reference[Removing the Duplexing Feed Front Cover]
- 2) Slide out the fixing/feeding unit. (page 9-19) Reference[Removing the Fixing/Feeding unit]
- 3) Remove the external delivery roller. (page 9-25) Reference[Removing the External Delivery Roller]

#### 9.5.14.2 Removing the External Delivery Sensor

iR5065 / iR 5055 / iR5075 / iR5075N / iR5065N / iR5055N

- 1) Slide out the sensor support plate.
  - 2 screws [1]

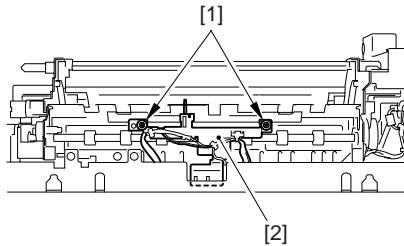

F-9-108

- 2) Remove the external delivery jam sensor [2] from the sensor support plate.
  - 1 connector [1]

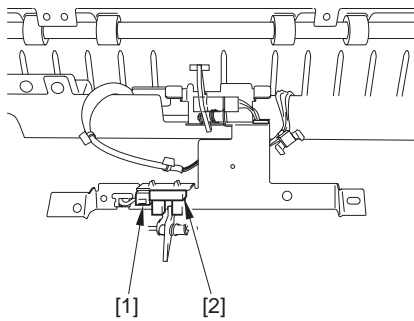

F-9-109

### 9.5.15 Internal Delivery Sensor

#### 9.5.15.1 Before Removing the Internal Delivery Sensor

iR5065 / iR 5055 / iR5075 / iR5075N / iR5065N / iR5055N

- 1) Detach the duplexing feed front cover. (page 10-14) Reference[Removing the Duplexing Feed Front Cover]
- 2) Slide out the fixing/feeding unit. (page 9-19) Reference[Removing the Fixing/Feeding unit]
- 3) Detach the fixing front cover. (page 10-16) Reference[Removing the Fixing Front Cover]
- 4) Detach the fixing/feeding unit front cover. (page 10-15) Reference[Removing the Fixing/Feeding Unit Front Cover]
- 5) Detach the fixing/feeding unit middle cover. (page 10-15) Reference[Removing the Fixing/Feeding Unit Middle Cover]
- 6) Detach the fixing upper cover. (page 10-15) Reference[Removing the Fixing Upper Cover]
- 7) Remove the fixing drive assembly. (page 10-22) Reference[Removing the Fixing Drive Assembly]
- 8) Remove the fixing upper unit. (page 9-20) Reference[Removing the Fixing Upper Unit]
- 9) Remove the lower separation claw unit. (page 9-39) Reference[Removing the Lower Separation Claw (Unit)]
- 10) Remove the internal delivery roller. (page 9-26) Reference[Removing the Internal Delivery Roller]

#### 9.5.15.2 Removing the Internal Delivery Sensor

iR5065 / iR 5055 / iR5075 / iR5075N / iR5065N / iR5055N

- 1) Remove the protrusion [2] to slide out the sensor support plate [3].
  - 1 screw [1]

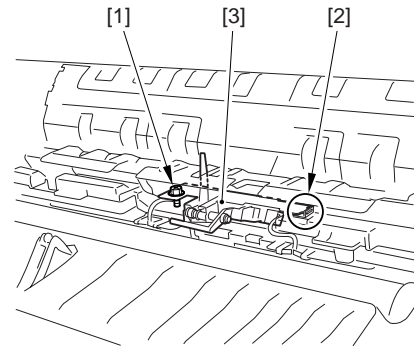

F-9-110

- 2) Remove the internal delivery sensor [2] from the sensor support plate.
  - 1 connector [1]

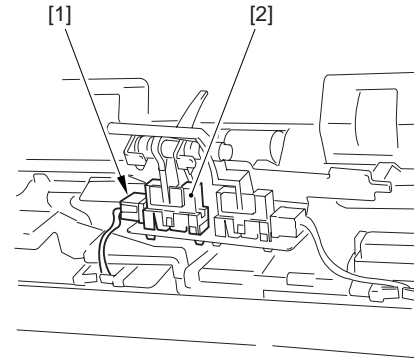

F-9-111

### 9.5.16 Fixing Inlet Sensor

#### 9.5.16.1 Before Removing the Fixing Inlet Sensor

iR5065 / iR 5055 / iR5075 / iR5075N / iR5065N / iR5055N

- 1) Detach the duplexing feed front cover. (page 10-14) Reference[Removing the Duplexing Feed Front Cover]
- 2) Slide out the fixing/feeding unit. (page 9-19) Reference[Removing the Fixing/Feeding unit]

#### 9.5.16.2 Removing the Fixing Inlet Sensor

iR5065 / iR 5055 / iR5075 / iR5075N / iR5065N / iR5055N

- 1) Check the positions (front, rear) of the fixing inlet guide base (the relative positions between the marking line of the fixing inlet guide base and the indexes of the height adjusting support plate). Then remove the 2 screws [3] and the 1 connector [4] and remove the fixing inlet guide base [5].

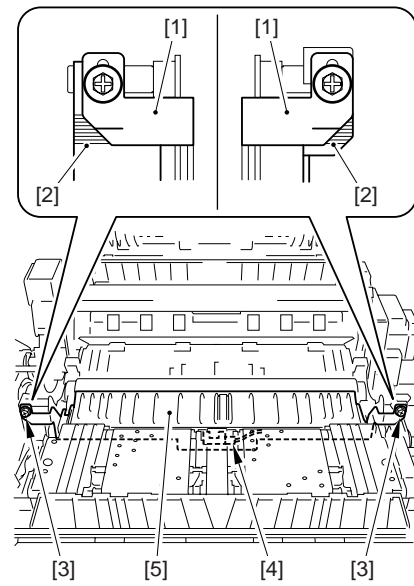

F-9-112

- 2) Remove the fixing inlet sensor [1] from the fixing inlet guide plate.

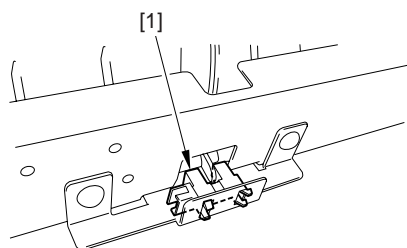

F-9-113



When mounting the fixing inlet guide base, be sure to mount it in the correct position as checked in the step 1).

### 9.5.16.3 Adjusting the Fixing Inlet Guide

iR5065 / iR 5055 / iR5075 / iR5075N / iR5065N / iR5055N

Adjust the solenoid position with the screw [1] so that the fixing inlet guide positions as indicated in the figure below when the solenoid is turned on.

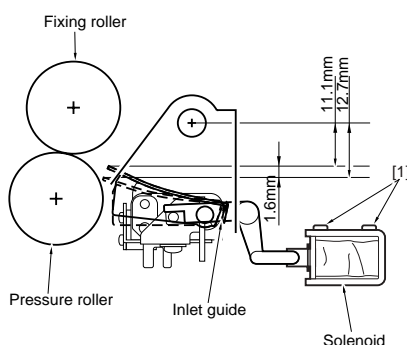

F-9-114

<Points to Note When Adjusting in the Field>

- The fixing inlet guide is at the lower position when the solenoid (SL1) is turned on.
- The heights at the front and rear sides of the fixing inlet guide should be adjusted within 0.2mm difference.
- Adjust the height of the fixing inlet guide by loosening the fixing screw on the height adjusting support plate.

### 9.5.17 Fixing web sensor

#### 9.5.17.1 Before Removing the Fixing Web Sensor

iR5065 / iR 5055 / iR5075 / iR5075N / iR5065N / iR5055N

- 1) Detach the fixing front cover. (page 10-16)Reference[Removing the Fixing Front Cover]
- 2) Remove the fixing drive assembly. (page 10-22)Reference[Removing the Fixing Drive Assembly]

#### 9.5.17.2 Removing the Fixing Web Sensor

iR5065 / iR 5055 / iR5075 / iR5075N / iR5065N / iR5055N

- 1) Remove the fixing web sensor [2].  
- 1 connector [1]

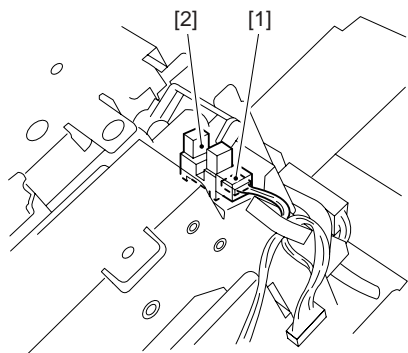

F-9-115

### 9.5.18 Fixing shutter sensor

#### 9.5.18.1 Before Removing the Shutter Sensor

iR5065 / iR 5055 / iR5075 / iR5075N / iR5065N / iR5055N

- 1) Detach the duplexing feed front cover. (page 10-14)Reference[Removing the Duplexing Feed Front Cover]
- 2) Slide out the fixing/feeding unit. (page 9-19)Reference[Removing the Fixing/Feeding unit]
- 3) Detach the fixing front cover. (page 10-16)Reference[Removing the Fixing Front Cover]
- 4) Detach the fixing/feeding unit front cover. (page 10-15)Reference[Removing the Fixing/Feeding Unit Front Cover]
- 5) Detach the fixing/feeding unit middle cover. (page 10-15)Reference[Removing the Fixing/Feeding Unit Middle Cover]
- 6) Detach the fixing upper cover. (page 10-15)Reference[Removing the Fixing Upper Cover]
- 7) Remove the fixing drive assembly. (page 10-22)Reference[Removing the Fixing Drive Assembly]
- 8) Remove the fixing upper unit. (page 9-20)Reference[Removing the Fixing Upper Unit]

#### 9.5.18.2 Removing the Shutter Sensor

iR5065 / iR 5055 / iR5075 / iR5075N / iR5065N / iR5055N

- 1) Remove the shutter sensor support plate [2].  
- 1 screw [1]

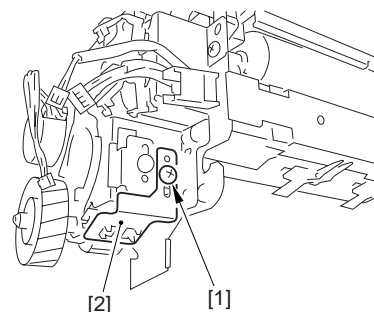

F-9-116

- 2) Remove the shutter sensor [1] from the shutter sensor support plate.

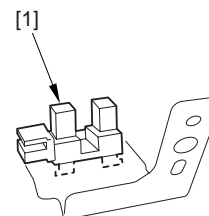

F-9-117

### 9.5.19 Fixing shutter motor

#### 9.5.19.1 Before Removing the Shutter Motor

iR5065 / iR 5055 / iR5075 / iR5075N / iR5065N / iR5055N

- 1) Detach the fixing front cover. (page 10-16)Reference[Removing the Fixing Front Cover]
- 2) Remove the fixing drive assembly. (page 10-22)Reference[Removing the Fixing Drive Assembly]

#### 9.5.19.2 Removing the Shutter Motor

iR5065 / iR 5055 / iR5075 / iR5075N / iR5065N / iR5055N

- 1) Free the harness from the harness guide [1] and remove the shutter motor [4].  
- 1 connector [2]  
- 2 screws [3]

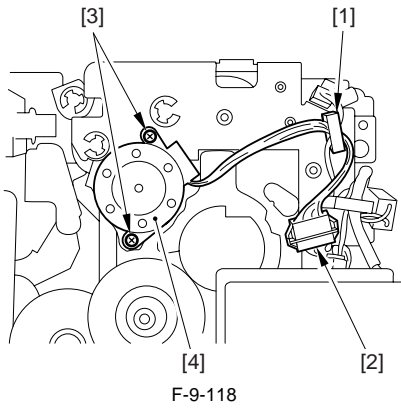

### 9.5.20 Fixing Inlet Guide Solenoid

#### 9.5.20.1 Before Removing the Fixing Inlet Guide Solenoid (SL1)

iR5065 / iR 5055 / iR5075 / iR5075N / iR5065N / iR5055N

- 1) Detach the fixing front cover. (page 10-16)Reference[Removing the Fixing Front Cover]
- 2) Detach the fixing/feeding unit front cover. (page 10-15)Reference[Removing the Fixing/Feeding Unit Front Cover]
- 3) Detach the fixing/feeding unit middle cover. (page 10-15)Reference[Removing the Fixing/Feeding Unit Middle Cover]

#### 9.5.20.2 Removing the Fixing Inlet Guide Solenoid (SL1)

iR5065 / iR 5055 / iR5075 / iR5075N / iR5065N / iR5055N

- 1) Free the harness from the wire saddle [3] and remove the harness guide.
  - 1 connector [1]
  - 1 screw [2]

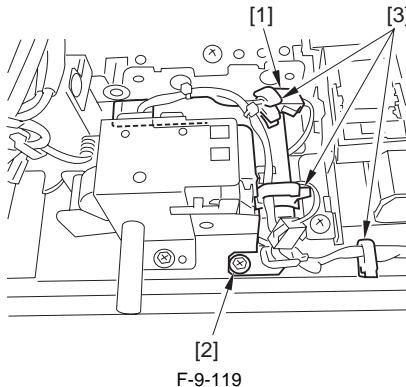

- 2) Remove the fixing/feeding unit releasing lever support plate [2].
  - 2 screws [1]

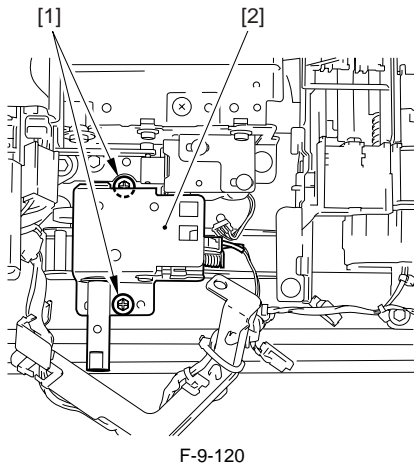

- 3) Remove the fixing inlet guide solenoid [2].
  - 2 screws [1]

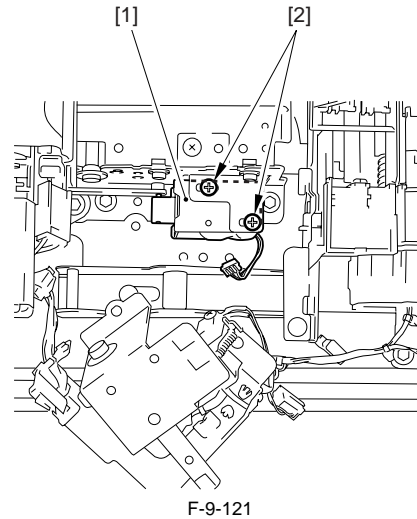

#### 9.5.20.3 Adjusting the Fixing Inlet Guide Solenoid (SL1)

iR5065 / iR 5055 / iR5075 / iR5075N / iR5065N / iR5055N

Adjust the position of the fixing inlet guide solenoid with the screw [1] so that the guide positions as shown in the figure below when the solenoid is turned on.

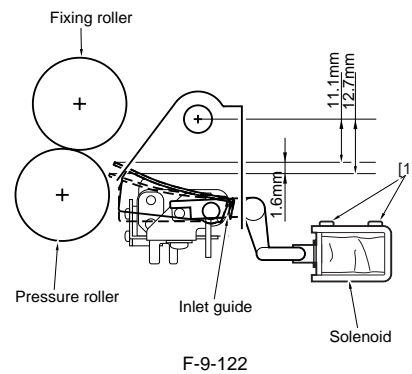

### 9.5.21 Delivery Flapper Solenoid

#### 9.5.21.1 Before Removing the Delivery Flapper Solenoid (SL5)

iR5065 / iR 5055 / iR5075 / iR5075N / iR5065N / iR5055N

- 1) Detach the duplexing feed front cover. (page 10-14)Reference[Removing the Duplexing Feed Front Cover]
- 2) Detach the fixing/feeding unit. (page 9-19)Reference[Removing the Fixing/Feeding unit]
- 3) Remove the external delivery roller. (page 9-25)Reference[Removing the External Delivery Roller]
- 4) Remove the sensor support plate (the external delivery sensor/the delivery jam sensor). (page 9-33)Reference[Removing the Delivery Jam Sensor]

#### 9.5.21.2 Removing the Delivery Flapper Solenoid (SL5)

iR5065 / iR 5055 / iR5075 / iR5075N / iR5065N / iR5055N

- 1) Free the harness from the wire saddle [4] and slide the delivery flapper solenoid [3] to the side to remove.
  - 1 connector [1]
  - 2 screws [2]

 Mark the screw positions before removing the screws in the next step.

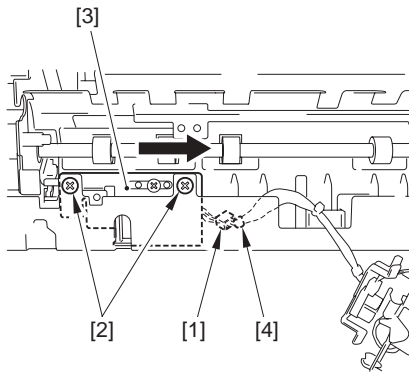

F-9-123

**9.5.21.3 Points to Note When Mounting the Delivery Flapper Solenoid (SL5)**

iR5065 / iR 5055 / iR5075 / iR5075N / iR5065N / iR5055N

When mounting the delivery flapper solenoid, be sure that the delivery flapper solenoid arm [1] and the sensor arm [2] position at the correct relative positions.

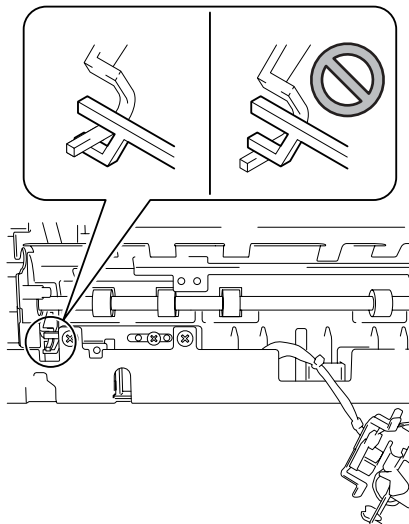

F-9-124

**9.5.22 Fixing Cleaning Web Solenoid**

**9.5.22.1 Before Removing the Fixing Web Solenoid (SL9)**

iR5065 / iR 5055 / iR5075 / iR5075N / iR5065N / iR5055N

- 1) Detach the fixing front cover. (page 10-16)Reference[Removing the Fixing Front Cover]
- 2) Remove the fixing drive assembly. (page 10-22)Reference[Removing the Fixing Drive Assembly]

**9.5.22.2 Removing the Fixing Web Solenoid (SL9)**

iR5065 / iR 5055 / iR5075 / iR5075N / iR5065N / iR5055N

**⚠**  
Mark the screw positions before removing the screws in the next step.

- 1) Remove the fixing web solenoid [3].
  - 1 connector [1]
  - 2 screws [2]

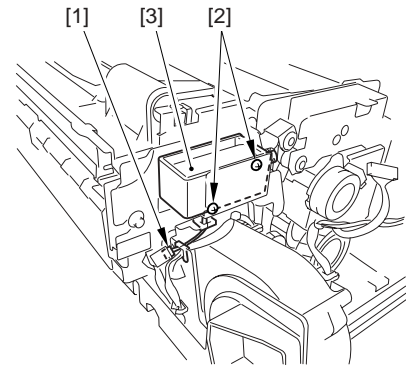

F-9-125

**9.5.22.3 Adjusting the Fixing Web Solenoid (SL9)**

iR5065 / iR 5055 / iR5075 / iR5075N / iR5065N / iR5055N

**a. For New Fixing Webs**

Adjust the solenoid position with the screw [2] so that the drive lever [1] can shift up to 8.6mm.

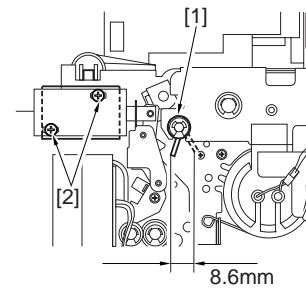

F-9-126

**b. For Used Fixing Webs**

Before removing the solenoid, check the position (A) of the drive lever [1] when the solenoid is turned on. After replacing the solenoid, adjust the drive lever [1] position with the screw [2] so that it positions as it did before replacement.

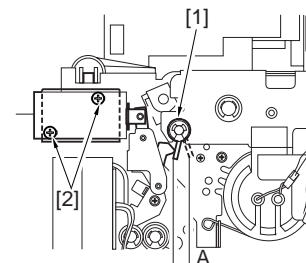

F-9-127

**9.5.23 Upper Separation Claw**

**9.5.23.1 Removing the Upper Separation Claw**

iR5065 / iR 5055 / iR5075 / iR5075N / iR5065N / iR5055N

- 1) Open the front cover [1].

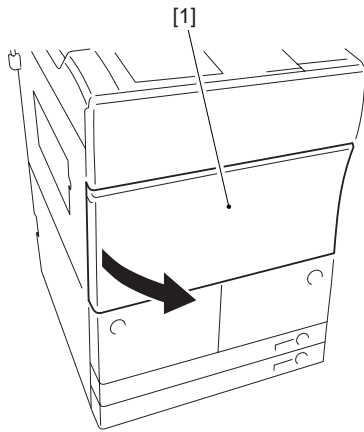

F-9-128

- 2) Turn the fixing/feeding unit releasing lever [1] counterclockwise to unlock. Hold the lever [1] to slide out the fixing/feeding unit [2] forward. (Note that the duplexing feed unit will also be slid out.)

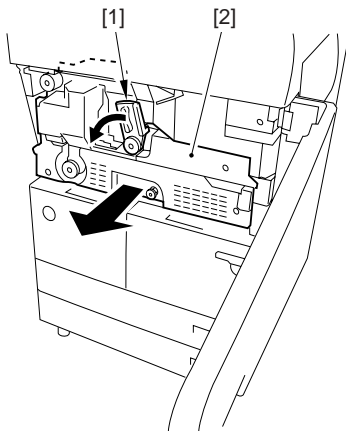

F-9-129

- 3) Open the delivery unit cover [1].

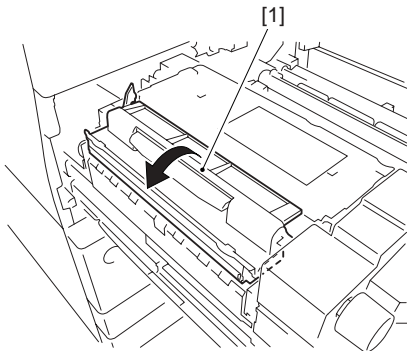

F-9-130

- 4) While lifting the spring [1], remove the upper separation claw [2].

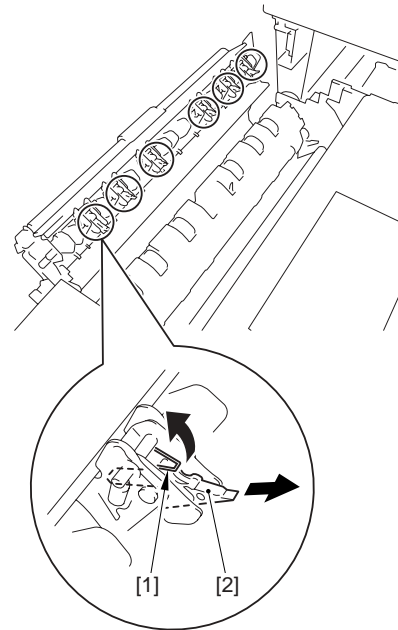

F-9-131

### 9.5.23.2 Points to Note When Mounting the Upper Separation Claw

iR5065 / iR 5055 / iR5075 / iR5075N / iR5065N / iR5055N

Pay attention to the relative positions between the upper separation claw and spring when mounting the upper separation claw.

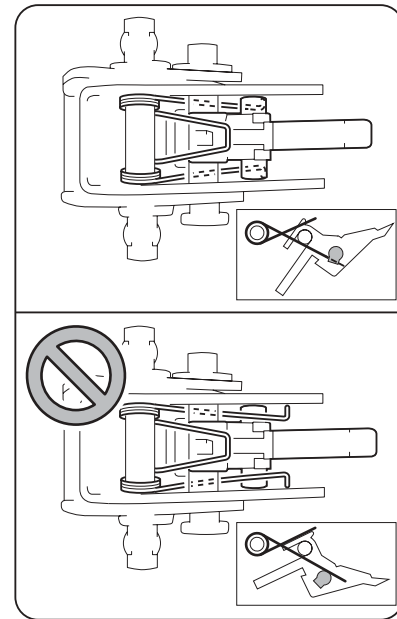

F-9-132

### 9.5.24 Lower Separation Claw

#### 9.5.24.1 Before Removing the Lower Separation Claw (Unit)

iR5065 / iR 5055 / iR5075 / iR5075N / iR5065N / iR5055N

- 1) Detach the duplexing feed front cover. (page 10-14)Reference[Removing the Duplexing Feed Front Cover]
- 2) Slide out the fixing/feeding unit. (page 9-19)Reference[Removing the Fixing/Feeding unit]
- 3) Detach the fixing front cover. (page 10-16)Reference[Removing the Fixing Front Cover]
- 4) Detach the fixing/feeding unit front cover. (page 10-15)Reference[Removing the Fixing/Feeding Unit Front Cover]
- 5) Detach the fixing/feeding unit middle cover. (page 10-15)Reference[Removing the Fixing/Feeding Unit Middle Cover]
- 6) Detach the fixing upper cover. (page 10-15)Reference[Removing the

Fixing Upper Cover]

- 7) Remove the fixing drive assembly. (page 10-22) Reference [Removing the Fixing Drive Assembly]
- 8) Remove the fixing upper unit. (page 9-20) Reference [Removing the Fixing Upper Unit]

### 9.5.24.2 Removing the Lower Separation Claw (Unit)

iR5065 / iR 5055 / iR5075 / iR5075N / iR5065N / iR5055N

- 1) Free the harness from the 4 clamps and disconnect the 1 connector [1].

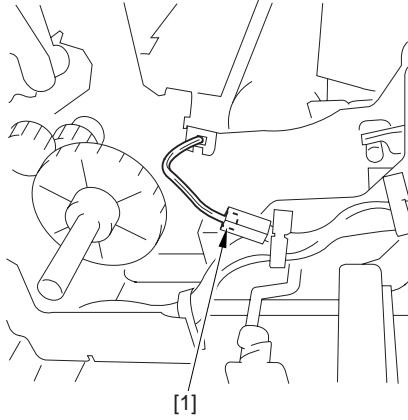

F-9-133

- 2) Remove the lower separation claw unit [2].  
- 2 screws [1]

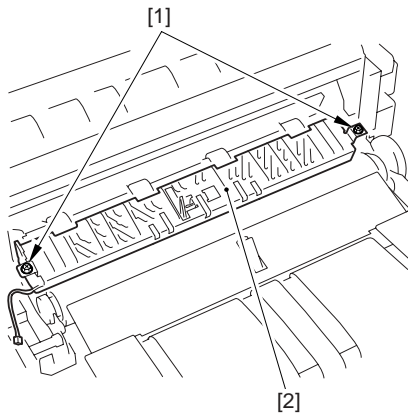

F-9-134



When removing the lower separation claw unit, follow the steps above. Follow the steps below when removing the lower separation claw.

- 3) Remove the 2 springs [1] from the lower separation claw.

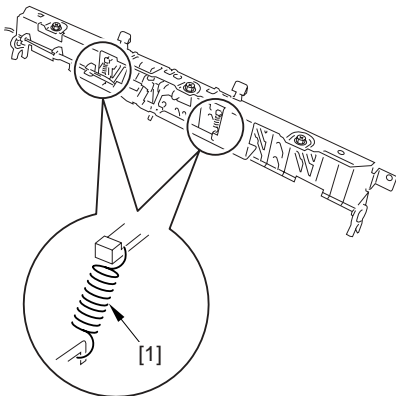

F-9-135

- 4) Remove the lower separation claw support plate [2] and remove the lower separation claw [3].  
- 3 screws [1]

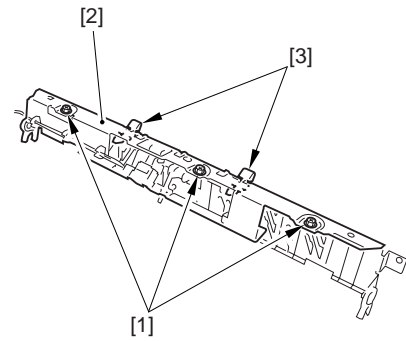

F-9-136





---

## Chapter 10 External and Controls

---



---

# Contents

10.1 Control Panel.....	10-1
10.1.1 Overview.....	10-1
10.1.2 LCD Indication Processing.....	10-1
10.1.3 Adjusting the LCD Contrast.....	10-1
10.1.4 Functions of the Control Panel CPU.....	10-1
10.2 Counters.....	10-1
10.2.1 Soft Counters.....	10-1
10.3 Fans.....	10-3
10.3.1 Arrangement, Functions, and Error Codes.....	10-3
10.3.2 Controlling the Speed of the Fans.....	10-4
10.3.3 Sequence of Operation.....	10-4
10.4 Power Supply System.....	10-5
10.4.1 Power Supply.....	10-5
10.4.1.1 Overview.....	10-5
10.4.1.2 Distribution of Power and the Switches.....	10-5
10.4.2 Rated Output of the DC Power Supply PCB.....	10-7
10.4.2.1 Rated Output of the DC Power Supply PCB.....	10-7
10.4.2.2 Rated Output of the Accessories Power Supply PCB.....	10-7
10.4.3 Protection Function.....	10-8
10.4.3.1 Protective Functions.....	10-8
10.4.4 Backup Battery.....	10-8
10.4.4.1 Backup Battery.....	10-8
10.4.5 Energy-Saving Function.....	10-8
10.4.5.1 Overview.....	10-8
10.4.5.2 SNMP setup.....	10-9
10.5 Parts Replacement Procedure.....	10-12
10.5.1 External Covers.....	10-12
10.5.1.1 Right Cover (Lower Rear).....	10-12
10.5.1.1.1 Removing the Right Cover (Lower Rear).....	10-12
10.5.1.2 Right Cover (Upper Rear).....	10-12
10.5.1.2.1 Removing the Right Cover (Upper Rear).....	10-12
10.5.1.3 Right Cover (Upper).....	10-12
10.5.1.3.1 Removing the Right Cover (Upper).....	10-12
10.5.1.4 Left Cover (Upper).....	10-12
10.5.1.4.1 Removing the Left Cover (Upper).....	10-12
10.5.1.5 Front Cover.....	10-13
10.5.1.5.1 Removing the Front Cover.....	10-13
10.5.1.6 Rear Cover (Upper).....	10-13
10.5.1.6.1 Removing the Rear Cover (Upper).....	10-13
10.5.1.7 Rear Cover (Lower).....	10-13
10.5.1.7.1 Before Removing the Rear Cover (Lower).....	10-13
10.5.1.7.2 Removing the Rear Cover (Lower).....	10-13
10.5.1.8 Left Cover (Lower).....	10-13
10.5.1.8.1 Before Removing the Left Cover (Lower).....	10-13
10.5.1.8.2 Removing the Left Cover (Lower).....	10-13
10.5.1.9 Left Cover (Middle).....	10-14
10.5.1.9.1 Removing the Left Cover (Middle).....	10-14
10.5.1.10 Toner Supply Cover.....	10-14
10.5.1.10.1 Removing the Toner Supply Cover.....	10-14
10.5.1.11 Fixing/Feeding Unit Cover.....	10-14
10.5.1.11.1 Removing the Duplexing Feed Front Cover.....	10-14
10.5.1.11.2 Removing the Fixing/Feeding Unit Front Cover.....	10-15
10.5.1.11.3 Removing the Fixing/Feeding Unit Middle Cover.....	10-15

10.5.1.12 Fixing Cover (Upper).....	10-15
10.5.1.12.1 Removing the Fixing Upper Cover.....	10-15
10.5.1.13 Fixing Cover (Lower).....	10-16
10.5.1.13.1 Removing the Fixing Front Cover.....	10-16
10.5.1.14 Main Controller Box Cover.....	10-17
10.5.1.14.1 Before Removing the Main Controller Box Cover.....	10-17
10.5.1.14.2 Removing the Main Controller Box Cover.....	10-17
10.5.1.15 Reader Left Cover.....	10-17
10.5.1.15.1 Removing the Reader Left Cover.....	10-17
10.5.1.16 Reader Right Cover.....	10-17
10.5.1.16.1 Removing the Reader Right Cover.....	10-17
10.5.1.17 Reader Front Cover.....	10-17
10.5.1.17.1 Before Detaching the Reader Front Cover.....	10-17
10.5.1.17.2 Detaching the Reader Front Cover.....	10-17
10.5.1.18 Reader Rear Cover.....	10-18
10.5.1.18.1 Detaching the Reader Rear Cover.....	10-18
10.5.2 Left Deck Drive Assembly.....	10-19
10.5.2.1 Before Removing the Left Deck Drive Assembly.....	10-19
10.5.2.2 Removing the Left Deck Drive Assembly.....	10-19
10.5.3 Manual Feed Pickup Drive Assembly.....	10-19
10.5.3.1 Before Removing the Manual Pickup Drive Assembly.....	10-19
10.5.3.2 Removing the Manual Pickup Drive Assembly.....	10-19
10.5.4 Vertical Path Drive Assembly.....	10-19
10.5.4.1 Before Removing the Vertical Path Drive Assembly.....	10-19
10.5.4.2 Removing the Vertical Path Drive Assembly.....	10-19
10.5.5 Waste Toner Drive Assembly.....	10-20
10.5.5.1 Before Removing the Collecting Toner Drive Assembly.....	10-20
10.5.5.2 Removing the Collecting Toner Drive Assembly.....	10-20
10.5.6 Main Drive Assembly.....	10-21
10.5.6.1 Fitting the Drive Belt.....	10-21
10.5.7 Cassette Pickup Drive Assembly.....	10-21
10.5.7.1 Before Removing the Cassette Pickup Drive Assembly.....	10-21
10.5.7.2 Removing the Cassette Pickup Drive Assembly.....	10-21
10.5.8 Fixing Drive Assembly.....	10-22
10.5.8.1 Before Removing the Fixing Drive Assembly.....	10-22
10.5.8.2 Removing the Fixing Drive Assembly.....	10-22
10.5.9 Power Supply Unit.....	10-22
10.5.9.1 Removing the Charger unit.....	10-22
10.5.9.2 Points to Note At Occurrence of Charger unit Malfunction.....	10-22
10.5.10 Duplex Unit PCB.....	10-23
10.5.10.1 Before Removing the Duplex unit PCB.....	10-23
10.5.10.2 Removing the Duplex Unit PCB.....	10-23
10.5.11 Control Panel.....	10-23
10.5.11.1 Before Removing Control Panel.....	10-23
10.5.11.2 Removing Control Panel.....	10-23
10.5.12 DC Controller PCB.....	10-24
10.5.12.1 Before Removing DC Controller PCB.....	10-24
10.5.12.2 Removing DC Controller PCB.....	10-24
10.5.12.3 When Replacing DC Controller PCB.....	10-24
10.5.13 Printer Power Supply PCB.....	10-24
10.5.13.1 Before Removing Printer Power Supply PCB.....	10-24
10.5.13.2 Removing Printer Power Supply PCB.....	10-24
10.5.14 Option Power Supply PCB.....	10-25
10.5.14.1 Before Removing Accessories Power Supply PCB.....	10-25
10.5.14.2 Removing Accessories Power Supply PCB.....	10-25
10.5.15 Fixing Heater Power Supply PCB.....	10-25
10.5.15.1 Before Removing Fixing Heater Power Supply PCB.....	10-25
10.5.15.2 Removing Fixing Heater Power Supply PCB.....	10-25
10.5.16 Anti-Rush Current PCB.....	10-26
10.5.16.1 Before Removing Anti-Rush Current PCB.....	10-26

10.5.16.2 Removing Anti-Rush Current PCB .....	10-26
10.5.17 High-Voltage Transformer (AC) .....	10-27
10.5.17.1 Before Removing High Voltage Transformer .....	10-27
10.5.17.2 Removing High Voltage Transformer .....	10-27
10.5.17.3 Removing High Voltage Transformer .....	10-27
10.5.18 HVT PCB .....	10-28
10.5.18.1 Before Removing HVT PCB .....	10-28
10.5.18.2 Removing HVT PCB .....	10-28
10.5.18.3 When Replacing HVT PCB .....	10-28
10.5.19 Separation Claw AC bias PCB .....	10-28
10.5.19.1 Before Removing Separation Claw AC PCB .....	10-28
10.5.19.2 Removing Separation Claw AC PCB .....	10-28
10.5.20 Motor Driver PCB .....	10-28
10.5.20.1 Before Removing Motor Driver PCB .....	10-28
10.5.20.2 Removing Motor Driver PCB .....	10-28
10.5.21 Primary Fan Duct .....	10-28
10.5.21.1 Before Removing Primary fan Duct .....	10-28
10.5.21.2 Removing Primary fan Duct .....	10-29
10.5.22 Primary Charging Assembly Fan .....	10-29
10.5.22.1 Before Removing Primary Charging Fan .....	10-29
10.5.22.2 Removing the Primary Charging Cooling Fan .....	10-29
10.5.23 De-Curling Fan .....	10-29
10.5.23.1 Before Removing the Curl-Removing Fan .....	10-29
10.5.23.2 Removing the Curl-Removing Fan .....	10-29
10.5.24 Feeding Fan .....	10-29
10.5.24.1 Before Removing the Feeding Fan .....	10-29
10.5.24.2 Removing the Feeding Fan .....	10-30
10.5.25 HVT Fan .....	10-30
10.5.25.1 Before Removing the HVT Fan .....	10-30
10.5.25.2 Removing the HVT Fan .....	10-30
10.5.26 Duplex Feed Fan .....	10-30
10.5.26.1 Before Removing the Duplex Feeding Fan .....	10-30
10.5.26.2 Removing the Duplex Feeding Fan .....	10-30
10.5.27 Exhaust Fan .....	10-31
10.5.27.1 Before Removing the Exhaust Fan .....	10-31
10.5.27.2 Removing the Exhaust Fan .....	10-31
10.5.28 DC Power Supply Fan .....	10-31
10.5.28.1 Before Removing the DC Power Supply Fan .....	10-31
10.5.28.2 Removing the DC Power Supply Fan .....	10-31
10.5.29 Fixing Heater Power Supply Cooling Fan .....	10-32
10.5.29.1 Before Removing the Fixing Heater Power Supply Cooling Fan .....	10-32
10.5.29.2 Removing the Fixing Heater Power Supply Cooling Fan .....	10-32
10.5.30 Circulation Duct Fan .....	10-32
10.5.30.1 Before Removing the Circulation Duct Fan .....	10-32
10.5.30.2 Removing the Circulation Duct Fan .....	10-32
10.5.31 Motor of Main Drive Assembly .....	10-33
10.5.31.1 Before Removing the Main Motor .....	10-33
10.5.31.2 Removing the Main Motor .....	10-33
10.5.32 Fixing Driver Motor .....	10-33
10.5.32.1 Before Removing the Fixing Motor .....	10-33
10.5.32.2 Removing the Fixing Motor .....	10-33
10.5.33 Right Door .....	10-34
10.5.33.1 Before Removing the Right Door Unit (Upper) .....	10-34
10.5.33.2 Removing the Right Door Unit (Upper) .....	10-34



## 10.1 Control Panel

### 10.1.1 Overview

iR5065 / iR 5055 / iR5075 / iR5075N / iR5065N / iR5055N

The machine's control panel consists of the following PCBs, LCD, and touch panel, and possesses the following principal functions:

- LCD indication
- contrast adjustment
- touch switch input
- hard key input

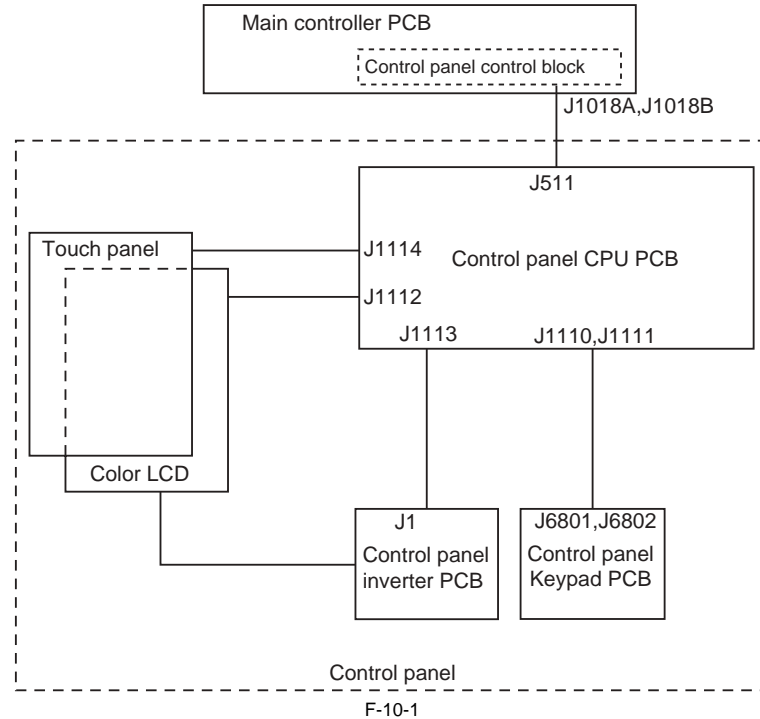

### 10.1.2 LCD Indication Processing

iR5065 / iR 5055 / iR5075 / iR5075N / iR5065N / iR5055N

The CPU found on the main controller PCB serves to feed data (display data) to the control panel CPU on the control panel according to program instructions. The data goes through the control panel CPU PCB to reach the color LCD.

### 10.1.3 Adjusting the LCD Contrast

iR5065 / iR 5055 / iR5075 / iR5075N / iR5065N / iR5055N

The machine is equipped with a density control volume (VR6801) on its keypad PCB so that the user can adjust the contrast of the LCD to suit individual needs.

### 10.1.4 Functions of the Control Panel CPU

iR5065 / iR 5055 / iR5075 / iR5075N / iR5065N / iR5055N

- Monitoring Key Inputs  
It communicates the inputs from the keypads and function keys to the CPU on the main control PCB.
- Monitoring the Touch Panel Inputs  
It communicates the inputs from the touch panel to the CPU on the main controller PCB.
- Controlling the Buzzer Sound
- Turning On Control Panel LEDs

#### MEMO:

The color LCD is operated by the main controller, and the control panel CPU PCB serves to relay the drive signal.

## 10.2 Counters

### 10.2.1 Soft Counters

iR5065 / iR 5055 / iR5075 / iR5075N / iR5065N / iR5055N

The machine possesses soft counters used to keep track of the number of prints it has made. The counter readings are indicated in response to a press on the Check key on the control panel.

The counters are controlled by the main controller PCB, and the readings are incremented in response to detection of paper by the following sensors at time of copier/printer operation:

T-10-1

Copier/printer operation	Counter name
Simplex mode	inside delivery paper sensor (PS35)
Duplex mode	duplex pre-registration sensor (PS30)
Finisher mode	delivery sensor

The counters may be grouped into 8 types, a total of 16 individual types when further divided according to paper size (large and small); specifically,

T-10-2

Copier/printer mode	Large size	Small size*1
Local copy	A	B
PDL print	C	D
Box print	E	F
Remote copy print	G	H
Fax reception print	I	J
Report print	K	L
Duplex print	M	N
Scan	O	P

\*1: at time of shipment, B4 or smaller.

If the user wants B4 to be counted as a large size, the setting may be changed in service mode.

The following shows the default counter types valid at time of shipment:

T-10-3

100V

Counter	Description*1	Default	Change
counter 1	total (A through L)	ON	not possible
counter 2	-	OFF	possible
counter 3	-	OFF	possible
counter 4	-	OFF	possible
counter 5	-	OFF	possible
counter 6	-	OFF	possible

T-10-4

120 V, 230 V (outside Europe)

Counter	Description*1	Default	Change
counter 1	total (A through L)	ON	not possible
counter 2	total, large (ACEGIK)	ON	possible
counter 3	copy (total 1; ABGH)	ON	possible
counter 4	copy (large; AG)	ON	possible
counter 5	-	OFF	possible
counter 6	-	OFF	possible

T-10-5



230V (inside Europe)

Counter	Description*1	Default	Change
counter 1	total (A through L)	ON	not possible
counter 2	total, large (ACEGIK)	ON	possible
counter 3	total, small (BDFHJL)	ON	possible
counter 4	scan (total 1; OP)	ON	possible
counter 5	-	OFF	possible
counter 6	-	OFF	possible

\*1: the notation in parentheses indicates the support mode of the basic counter.

\*2: the counter type may be changed or counter display may be enabled or disabled in service mode (not applicable to counter 1).

## 10.3 Fans

### 10.3.1 Arrangement, Functions, and Error Codes

iR5065 / iR 5055 / iR5075 / iR5075N / iR5065N / iR5055N

T-10-6

The following shows the names of the fans mounted to the machine and the functions and error codes associated with them:

T-10-7

Notation	Name	Function	2-speed control (voltage)	Error code
FM1	feed fan	keeps print paper to feed belt	yes (24/12 V)	E805-0002
FM2	primary charging cooling fan	cools the primary charging assembly and the cleaner	yes (24/12 V)	E824-0001
FM3	heat discharge fan	discharges exhaust of fans outside the machine	yes (24/12 V)	E805-0001
FM4	controller cooling fan	cools the laser unit, developing block drive block, and controller	yes (24/12 V)	E121-0001
FM5	curl-removing fan	removes curl from print paper after fixing	yes (24/12 V)	-
FM6	DC power supply fan	cools power supply PCB	yes (24/12 V)	E804-0000
FM7	fixing heater power supply cooling fan	cools fixing power supply	yes (24/12 V)	E804-0001
FM8	duplex feed fan	cools the duplex feed motor	non (24 V)	-
FM9	circulation duct fan	cools the inside of the machine	yes (24/12 V)	-
FM10	ACC (accessory) power supply fan	cools the ACC power supply	yes (24/12 V)	E804-0002
FM11	HVT fan	cools the HVT unit	yes (24/12 V)	-
FM501	reader unit cooling fan	cools the reader unit	no (24 V)	-

T-10-8

The following shows the arrangement of the fans and the direction of air current:

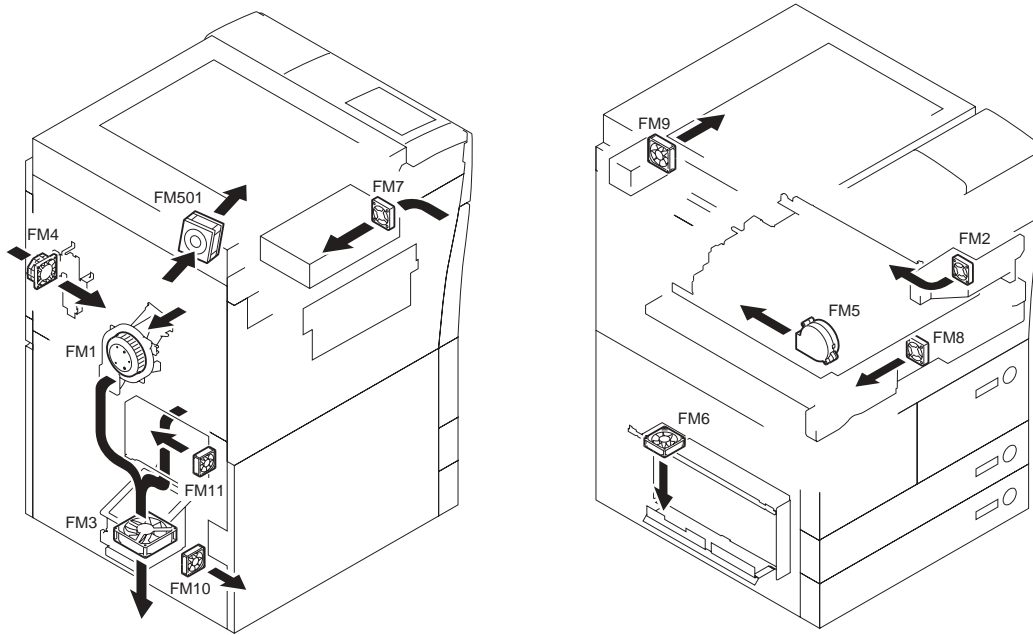

F-10-2

### 10.3.2 Controlling the Speed of the Fans

iR5065 / iR 5055 / iR5075 / iR5075N / iR5065N / iR5055N

Some of the fans mounted in the machine are controlled to 2 different speeds, switched over by the voltage switchover circuit of individual fans.

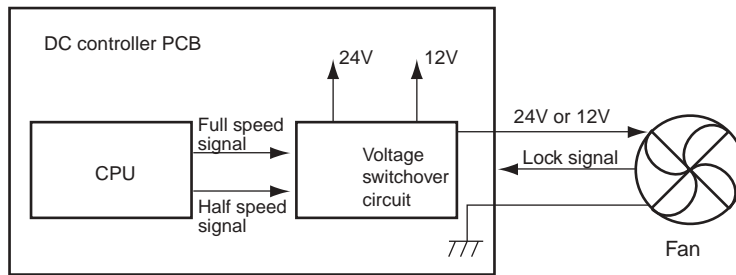

F-10-3

### 10.3.3 Sequence of Operation

iR5065 / iR 5055 / iR5075 / iR5075N / iR5065N / iR5055N

Printer unit status	Main power switch ON							Main power switch OFF			
	WMUP	WMUPR	Standby	Printing	After printing	Power save	Sleep 1	Jam	Door open	Sleep 3	In reader operation
Feed fan (FM1)				■	■	■	■	■	■	■	■
Primary charging cooling fan (FM2)				■	■	■	■	■	■	■	■
Heat discharge fan (FM3)				■	■	■	■	■	■	■	■
Controller cooling fan (FM4)				■	■	■	■	■	■	■	■
Curli-removing fan (FM5)				■	■	■	■	■	■	■	■
DC power supply fan (FM6)	■	■	■	■	■	■	■	■	■	■	■
Fixing power supply cooling fan (FM7)				■	■	■	■	■	■	■	■
Duplex feeding fan (FM8)				■	■	■	■	■	■	■	■
Circulation duct fan (FM9)				■	■	■	■	■	■	■	■
Accessories power supply fan (FM10)				■	■	■	■	■	■	■	■
HVT fan (FM11)				■	■	■	■	■	■	■	■

■: full speed    ▨: half speed

F-10-4

## 10.4 Power Supply System

### 10.4.1 Power Supply

#### 10.4.1.1 Overview

iR5065 / iR 5055 / iR5075 / iR5075N / iR5065N / iR5055N

The supply of DC power of the machine is controlled by the DC power supply PCB. The following shows the various PCBs and components associated with the supply of DC power:

T-10-9

Name	Description
ACC power supply PCB	-generates DC power from AC power -protects against overcurrent -power supply to reader and charger unit
DC power supply PCB	-generates DC power from AC power -protects against overcurrent
Rush current prevention PCB	-limits rush current for the fixing feed unit, duplex unit, and high-voltage PCB
Main power switch (SW1)	-serves as the power switch for loads other than the drum heater (H3), cassette heater (H4), and deck heater (H5)
Environment switch (SW3)	-turns on/off the drum heater (H3), cassette heater (H4), and deck heater (H5)
Cassette heater switch (SW4)	- turns on/off the cassette heater (H4) and the deck heater

#### 10.4.1.2 Distribution of Power and the Switches

iR5065 / iR 5055 / iR5075 / iR5075N / iR5065N / iR5055N

The various loads of the machine are supplied with power by means of the following switches:

##### 1. 100V Model

T-10-10

	Main power switch OFF		Sleep		Warm-up (other than initial)		Standby/ power save		Copying/ printing	
Env.switch	OFF									
Main switch	OFF		ON							
Cassette switch	OFF	ON	OFF	ON	OFF	ON	OFF	ON	OFF	ON
Latch relay RL	OFF	OFF	OFF	OFF	OFF	OFF	ON	ON	ON	ON
Drum heater	OFF	OFF	OFF	OFF	OFF	OFF	ON/ OFF	ON/ OFF	ON/ OFF	ON/ OFF
Cassette heater	ON	ON	ON	ON	OFF	OFF	ON	ON	ON	ON
Reader unit heater	OFF	OFF	OFF	OFF	OFF	OFF	OFF	OFF	OFF	OFF

T-10-11

	Main power switch OFF		Sleep		Warm-up (other than initial)		Standby/ power save		Copying/ printing	
Env. switch	ON									
Main switch	OFF		ON							
Cassette switch	OFF	ON	OFF	ON	OFF	ON	OFF	ON	OFF	ON
Latch relay RL	ON	ON	OFF	OFF	ON	ON	ON	ON	ON	ON
Drum heater	ON	ON	ON/ OFF	ON/ OFF	OFF	OFF	ON/ OFF	ON/ OFF	ON/ OFF	ON/ OFF
Cassette heater	ON	ON	ON	ON	OFF	OFF	ON	ON	ON	ON
Reader unit heater	ON	ON	ON	ON	OFF	OFF	OFF	OFF	OFF	OFF

##### 2. 120/230-V Model

T-10-12

	Main power switch OFF		Sleep		Warm-up (other than initial)		Standby/ power save		Copying/ printing	
Env. switch	OFF									
Main power switch	OFF				ON					
Cassette switch	OFF	ON	OFF	ON	OFF	ON	OFF	ON	OFF	ON
Control relay	OFF	OFF	OFF	OFF	ON	ON	ON	ON	ON	ON
Drum heater	OFF	OFF	OFF	OFF	ON	ON	ON	ON	ON	ON
Cassette heater	ON	ON	ON	ON	OFF	OFF	ON	ON	ON	ON
Reader unit heater	OFF	OFF	OFF	OFF	OFF	OFF	OFF	OFF	OFF	OFF

T-10-13

	Main power switch OFF		Sleep		Warm-up (other than initial)		Standby/ power save		Copying/ printing	
Env. switch	ON									
Main switch	OFF				ON					
Cassette switch	OFF	ON	OFF	ON	OFF	ON	OFF	ON	OFF	ON
Control relay	OFF	OFF	OFF	OFF	ON	ON	ON	ON	ON	ON
Drum heater	ON	ON	ON	ON	ON	ON	ON	ON	ON	ON
Cassette heater	ON	ON	ON	ON	OFF	OFF	ON	ON	ON	ON
Reader unit heater	ON	ON	ON	ON	OFF	OFF	OFF	OFF	OFF	OFF

The following shows the default settings of the machine's environment switch (SW3) and cassette heater switch (SW4):

T-10-14

Default setting	100-V model	120-V model	230-V model
Environment switch	ON	OFF	OFF
Cassette heater switch	OFF	not present	OFF

The following shows the distribution of power inside the machine:

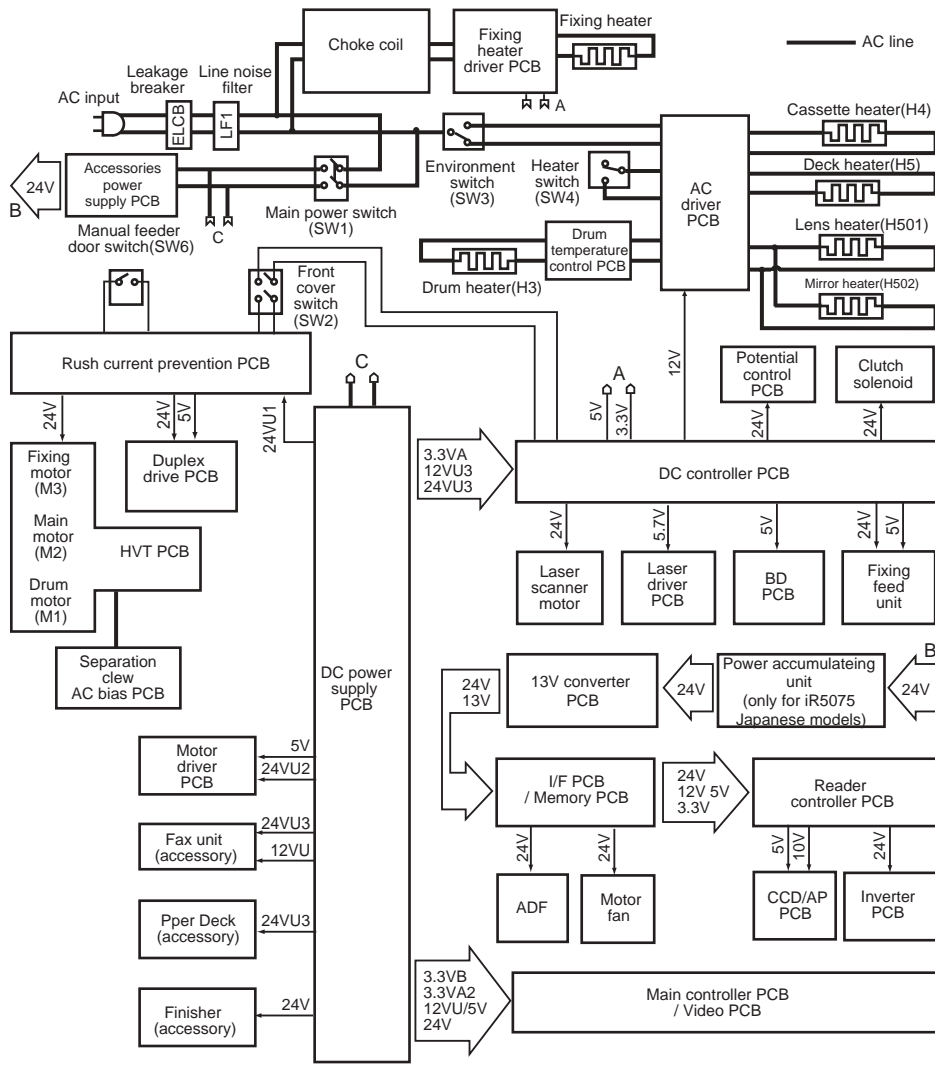

F-10-5

**10.4.2 Rated Output of the DC Power Supply PCB**

**10.4.2.1 Rated Output of the DC Power Supply PCB**

iR5065 / iR 5055 / iR5075 / iR5075N / iR5065N / iR5055N

The following shows the ratings and the power supply tolerances of the DC power supply PCB:  
T-10-15

Output	5VA	3VA1 3VA2 3VA3	3VB	24VU1 24VU2 24VU3 24VU4	12VU
Uninterruptive/ interruptive	interruptive	interruptive	uninterruptive	interruptive	interruptive
Rated output	+5.10V	+3.40V	+3.50V	+24.0V	+12.0V
Power supply tolerance	+/-3%	3.25-3.46V	+/-2% (1.0-2.0A)	+/-5%	+/-5%

**10.4.2.2 Rated Output of the Accessories Power Supply PCB**

iR5065 / iR 5055 / iR5075 / iR5075N / iR5065N / iR5055N

The following shows the ratings and the power supply tolerances of the accessories power supply PCB:

T-10-16

Output	24VA
Uninterruptive/ interruptive	interruptive
Rated output	24V
Power supply tolerance	+7-5%

### 10.4.3 Protection Function

#### 10.4.3.1 Protective Functions

iR5065 / iR 5055 / iR5075 / iR5075N / iR5065N / iR5055N

The machine's DC power supply PCB and the power supply PCB for its accessories are equipped with overcurrent and overvoltage protective functions that will cut off power to prevent damage to circuitry in the event of an overcurrent or overvoltage occurring as a result of a short circuit or other fault.

A fault in 3VB (uninterruptive power supply) will cut off all power of the machine; on the other hand, a fault in any other power supply will cut off all power to loads other than 3VB (uninterruptive power supply).

If a fault has occurred in 3VB (uninterruptive power supply), turn off the main power switch of the printer unit, and remove the cause that has activated the protective circuit; then, replace the DC power supply PCB. (The fuse on the DC power supply PCB is likely to have blown.)

Other than that, turn off the main power switch of the printer unit, and remove the cause that has activated the protective circuit; then, leave the machine alone for about 3 min or more, and turn the power back on to reset the protective circuit.

### 10.4.4 Backup Battery

#### 10.4.4.1 Backup Battery

iR5065 / iR 5055 / iR5075 / iR5075N / iR5065N / iR5055N

The machine's main controller PCB and DC controller PCB are equipped with each of one lithium battery that serves as a source of backup power to retain various data in the event of a power outage or disconnection of the power plug.

T-10-17

Battery specifications	manganese dioxide lithium battery (3 V, 1000 mAh)
Battery life	main controller PCB: about 8.8 yr (with power plug disconnected)
Battery replacement	not possible in the field on its own



You must always be sure that the battery is replaced correctly. Be sure to replace it with a battery of a type indicated by the manufacturer of the unit (bearing the same model name or equivalent).

Be sure also to dispose of the removed battery as instructed by the manufacturer of the battery.

### 10.4.5 Energy-Saving Function

#### 10.4.5.1 Overview

iR5065 / iR 5055 / iR5075 / iR5075N / iR5065N / iR5055N

##### 1. Standby State

When the machine is in a standby state, all its loads are supplied with power and the machine is ready to start operation at any time.

##### 2. Sleep State

###### 2-1. Sleep 1

When the machine is in sleep 1, its laser scanner will not rotate even when a key on the control panel is pressed.

###### 2-2. Sleep 3

When the machine is in sleep 3, only 3VB on the DC power supply PCB is supplied with power.

The machine moves from sleep 3 to standby in response to the following:

- print job
- press on the control panel power switch
- fax reception
- fax delayed transmission

The following shows the loads that remain supplied with power when the machine is in sleep 3.

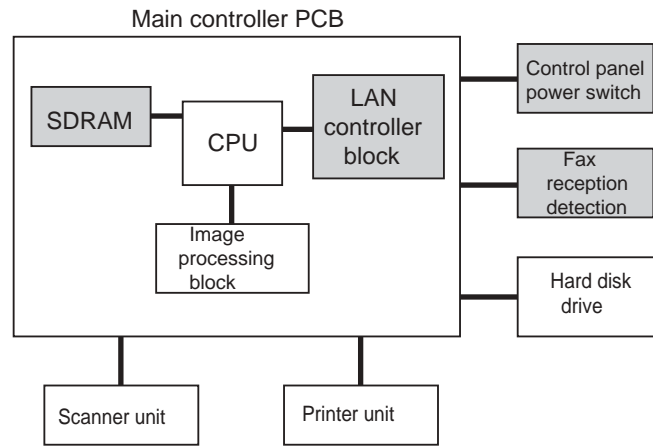

F-10-6

### 3. AC Off State

The machine is in an AC off state when its main power switch remains off, with all its power supplies and heater control mechanisms also remaining off.

### 4. Power Supply Arrangement

The following shows how the various loads of the machine are supplied with power while the machine is in individual states:

T-10-18

Operation set		AC off	Sleep 3	Front door open	Sleep 1	Standby, copying, power save
Input	Main power switch	OFF	ON	ON	ON	ON
	Front door switch	-	-	OFF	ON	ON
	RMT2*	-	0	1	1	1
Output	3VB	OFF	ON	ON	ON	ON
	3VB	OFF	OFF	ON	ON	ON
	5V	OFF	OFF	ON	ON	ON
	12VU	OFF	OFF	ON	ON	ON
	24VU1	OFF	OFF	ON	ON	ON
	24VU2/3/4	OFF	OFF	OFF	ON	ON

\*Output from the main controller PCB.

#### 10.4.5.2 SNMP setup

iR5065 / iR 5055 / iR5075 / iR5075N / iR5065N / iR5055N

When the machine is used as a Windows printer, enabling 'Use SNMP' causes the operating system to collect machine status information at specific intervals, preventing the machine from starting a sleep state.

To avoid the situation, disable the setting (Windows' printer properties).

-Disabling 'Use SNMP'

1) Select 'Configure Port' on the Ports screen (printer properties).

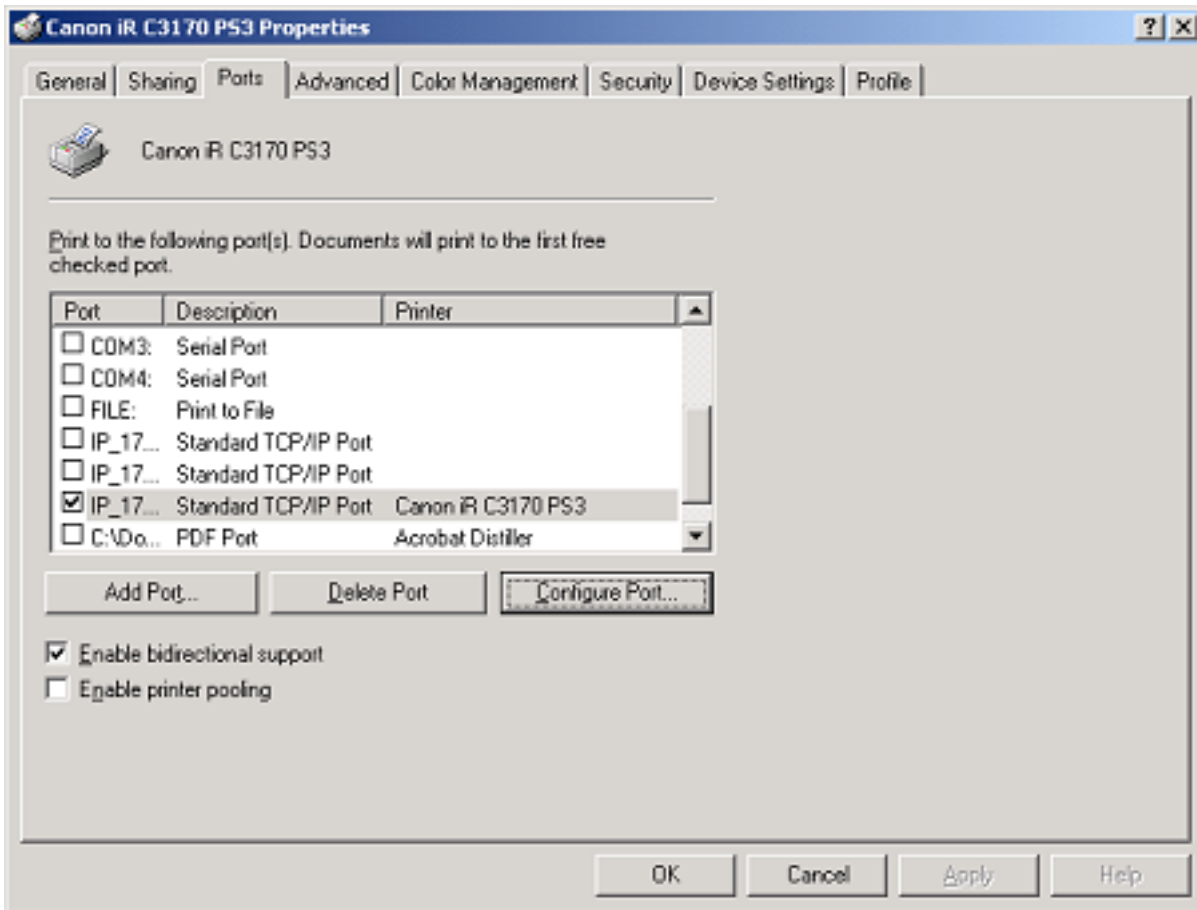

F-10-7

2) Remove the check mark from 'SNMP Status Enabled'.



**Configure Standard TCP/IP Port Monitor** ? X

Port Settings

Port Name: IP\_172.16.185.236

Printer Name or IP Address: 172.16.185.236

Protocol

Raw  LPR

Raw Settings

Port Number: 9100

LPR Settings

Queue Name:

LPR Byte Counting Enabled

SNMP Status Enabled

Community Name: public

SNMP Device Index: 1

OK Cancel

F-10-8

## 10.5 Parts Replacement Procedure

### 10.5.1 External Covers

#### 10.5.1.1 Right Cover (Lower Rear)

##### 10.5.1.1.1 Removing the Right Cover (Lower Rear)

0015-6693

iR5065 / iR 5055 / iR5075 / iR5075N / iR5065N / iR5055N

- 1) Detach the right cover (lower rear)[2].  
- 2 screws [1]

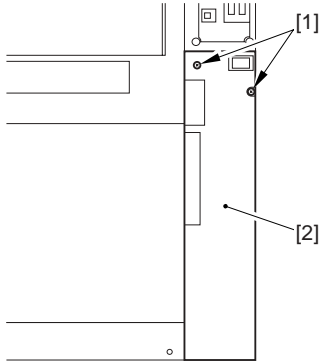

F-10-9

#### 10.5.1.2 Right Cover (Upper Rear)

##### 10.5.1.2.1 Removing the Right Cover (Upper Rear)

0015-8142

iR5065 / iR 5055 / iR5075 / iR5075N / iR5065N / iR5055N

- 1) Disconnect the connector [1] of the reader unit communication cable.

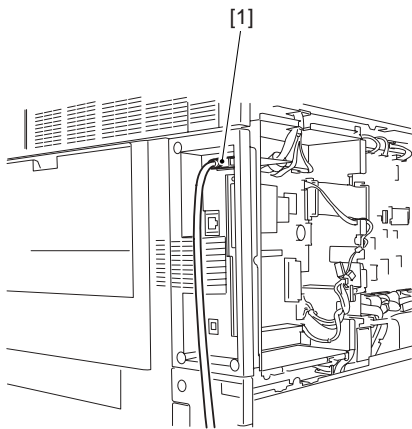

F-10-10

- 2) Detach the right cover (upper rear) [2].  
- 2 screws [1]

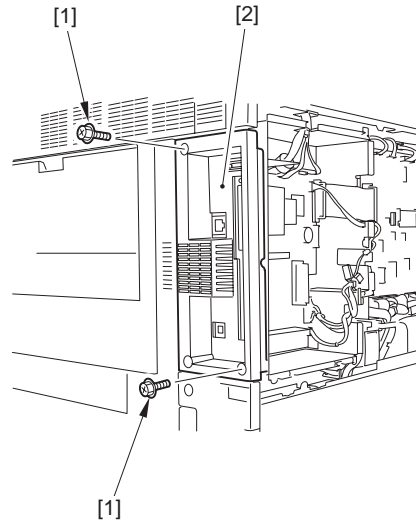

F-10-11

#### 10.5.1.3 Right Cover (Upper)

##### 10.5.1.3.1 Removing the Right Cover (Upper)

0015-6683

iR5065 / iR 5055 / iR5075 / iR5075N / iR5065N / iR5055N

- 1) Open the toner supply cover [1].
- 2) Detach the right cover (upper) [3].  
- 2 screws [2]

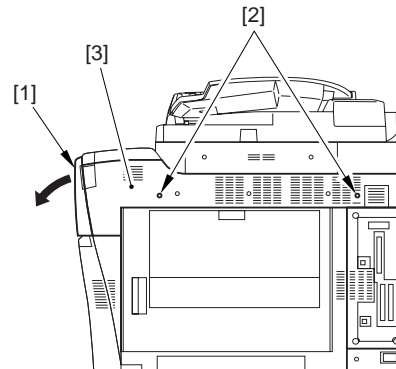

F-10-12

#### 10.5.1.4 Left Cover (Upper)

##### 10.5.1.4.1 Removing the Left Cover (Upper)

0015-6680

iR5065 / iR 5055 / iR5075 / iR5075N / iR5065N / iR5055N

- 1) Detach the left cover (upper) [2].  
- 2 screws [1]

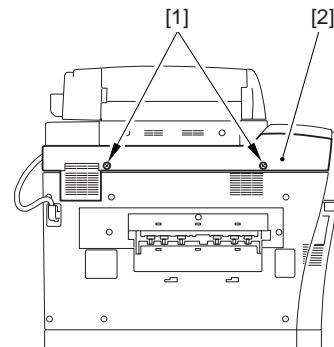

F-10-13

### 10.5.1.5 Front Cover

#### 10.5.1.5.1 Removing the Front Cover

iR5065 / iR 5055 / iR5075 / iR5075N / iR5065N / iR5055N

0015-6691

- 1) Pull the pin [2] up to draw out.
  - Stopper [1] (Pull forward to remove)
- 2) Lift the front cover [3] to detach.
  - 1 screw [4]

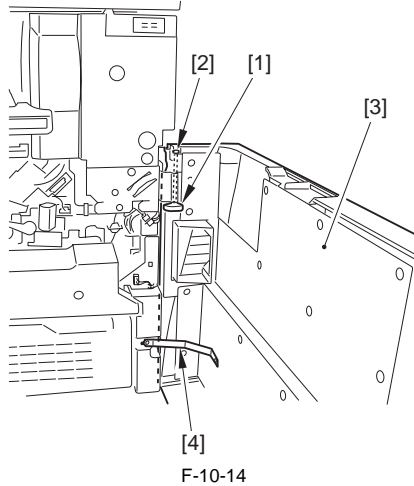

F-10-14

#### 10.5.1.6 Rear Cover (Upper)

##### 10.5.1.6.1 Removing the Rear Cover (Upper)

iR5065 / iR 5055 / iR5075 / iR5075N / iR5065N / iR5055N

0015-6682

- 1) Open the wire saddle [1] and disconnect the connector [2] of the reader unit communication cable.

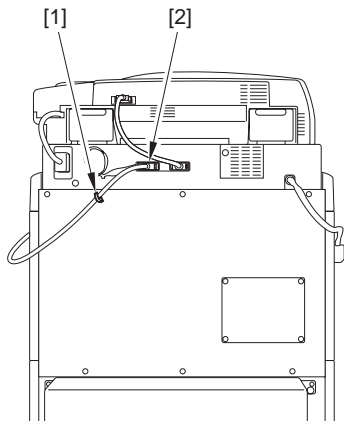

F-10-15

- 2) Detach the rear cover (upper) [2].
  - 6 screws [1]

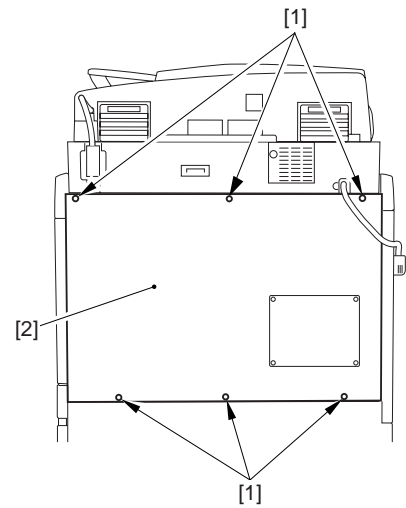

F-10-16

#### 10.5.1.7 Rear Cover (Lower)

##### 10.5.1.7.1 Before Removing the Rear Cover (Lower)

iR5065 / iR 5055 / iR5075 / iR5075N / iR5065N / iR5055N

0015-8306

- 1) Remove the charger unit (this step is necessary only for iR5075 for Japan).  
(page 10-22)Reference[Removing the Charger unit]
- 2) Remove the rear cover (upper). (page 10-13)Reference[Removing the Rear Cover (Upper)]

##### 10.5.1.7.2 Removing the Rear Cover (Lower)

iR5065 / iR 5055 / iR5075 / iR5075N / iR5065N / iR5055N

0015-6688

- 1) Detach the rear cover (lower) [2].
  - 8 screws [1]

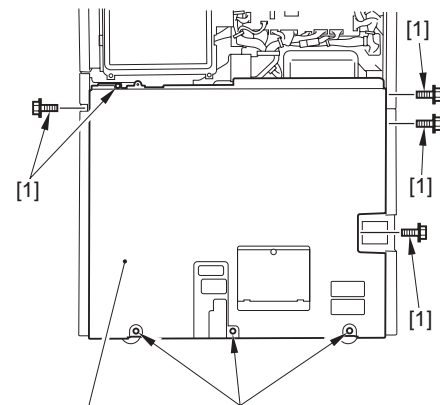

F-10-17

#### 10.5.1.8 Left Cover (Lower)

##### 10.5.1.8.1 Before Removing the Left Cover (Lower)

iR5065 / iR 5055 / iR5075 / iR5075N / iR5065N / iR5055N

0015-8309

- 1) Detach the left cover (middle). (page 10-14)Reference[Removing the Left Cover (Middle)]

##### 10.5.1.8.2 Removing the Left Cover (Lower)

iR5065 / iR 5055 / iR5075 / iR5075N / iR5065N / iR5055N

0015-6695

- 1) Remove the 2 grip covers [1].
- 2) Slide out the left deck [2], the cassette 3 [3] and the cassette 4 [4].
- 3) Detach the left cover (lower) [6].
  - 6 screws [5]

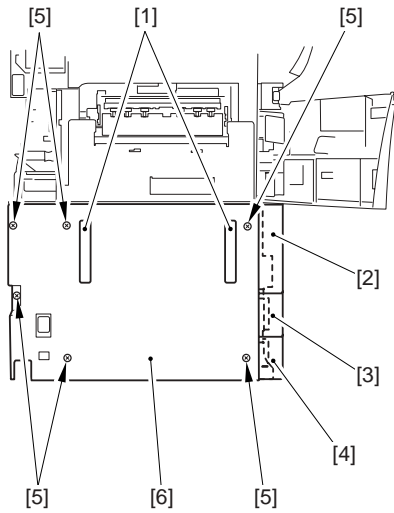

F-10-18

**10.5.1.9 Left Cover (Middle)**

**10.5.1.9.1 Removing the Left Cover (Middle)**

iR5065 / iR 5055 / iR5075 / iR5075N / iR5065N / iR5055N

0015-6681

- 1) Detach the delivery cover [2].  
- 3 screws [1]
- 2) Disconnect the reader power cable [3].
- 3) Open the front cover [4].
- 4) Open the toner supply cover [5].
- 5) Detach the left cover (middle) [7].  
- 6 screws [6]

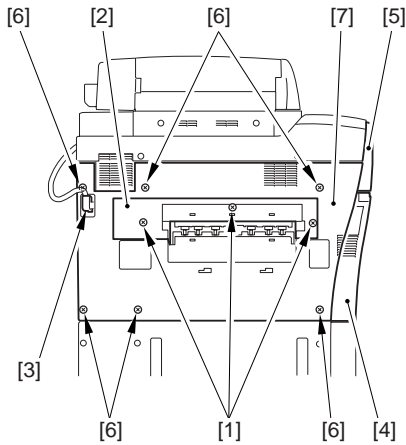

F-10-19

**10.5.1.10 Toner Supply Cover**

**10.5.1.10.1 Removing the Toner Supply Cover**

iR5065 / iR 5055 / iR5075 / iR5075N / iR5065N / iR5055N

0015-8152

- 1) Open the front cover [1].

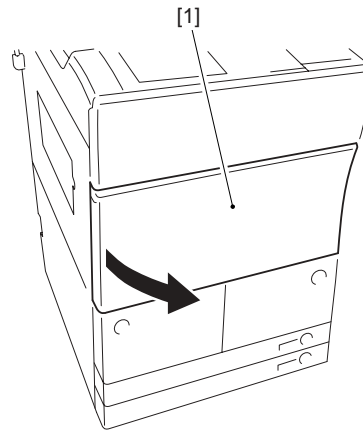

F-10-20

- 2) Detach the toner supply cover [2].  
- 2 screws [1] (Detach with the cover closed.)

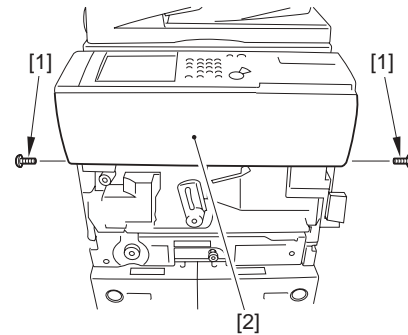

F-10-21

**10.5.1.11 Fixing/Feeding Unit Cover**

**10.5.1.11.1 Removing the Duplexing Feed Front Cover**

iR5065 / iR 5055 / iR5075 / iR5075N / iR5065N / iR5055N

0015-8201

- 1) Open the front cover [1].

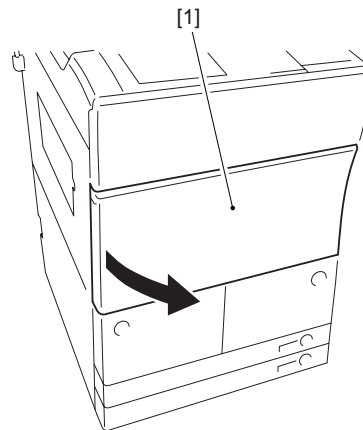

F-10-22

- 2) Turn the fixing/feeding unit releasing lever [1] counterclockwise to unlock. Hold the lever to slide out the fixing/feeding unit [2] fully. (The duplexing feed unit will be also slid out.)

**MEMO:**

Perform the step above when sliding out the fixing/feeding unit. When removing the duplexing feed unit, slide out the duplexing feed unit only.

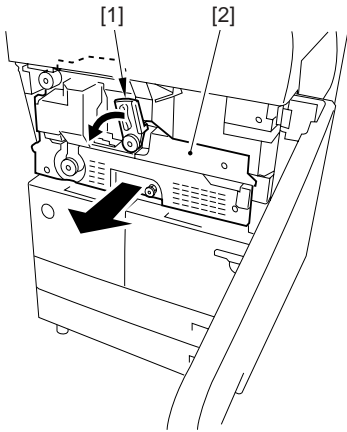

F-10-23

- 3) Remove the 2 jam removal levers [1] of the duplexing feed unit and detach the duplexing feed front cover [3].  
- 3 screws [2]

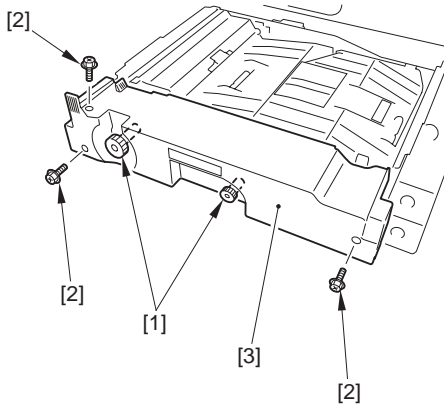

F-10-24

**10.5.1.11.2 Removing the Fixing/Feeding Unit Front Cover**

iR5065 / iR 5055 / iR5075 / iR5075N / iR5065N / iR5055N

0015-8258

- 1) Open the front cover [1].

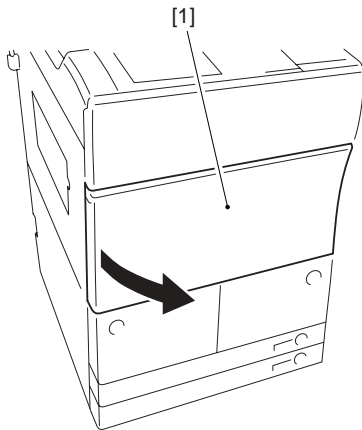

F-10-25

- 2) Turn the fixing/feeding unit releasing lever [1] counterclockwise to unlock. Hold the lever [1] to slide out the fixing/feeding unit [2] fully. (The duplexing feed unit will also be slid out.)

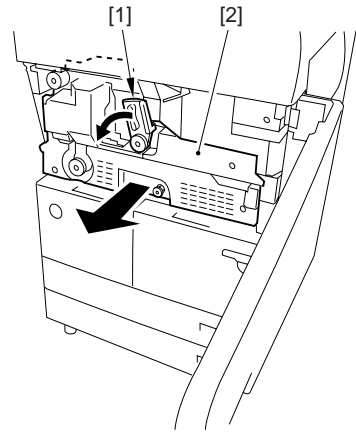

F-10-26

- 3) Detach the feeding assembly front cover (right) [2].  
- 2 screws [1]

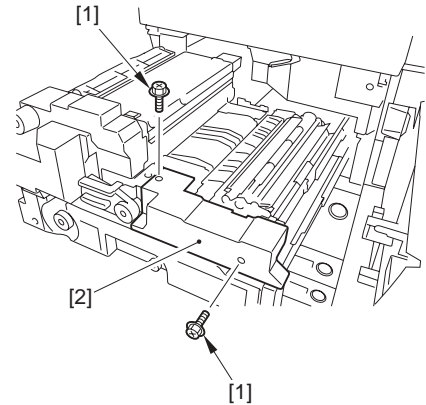

F-10-27

**10.5.1.11.3 Removing the Fixing/Feeding Unit Middle Cover**

iR5065 / iR 5055 / iR5075 / iR5075N / iR5065N / iR5055N

0015-8259

- 1) Detach the fixing front cover. (page 10-16)Reference[Removing the Fixing Front Cover]  
2) Detach the fixing/feeding unit front cover. (page 10-15)Reference[Removing the Fixing/Feeding Unit Front Cover]  
3) Detach the fixing/feeding unit middle cover [2].  
- 2 screws [1]

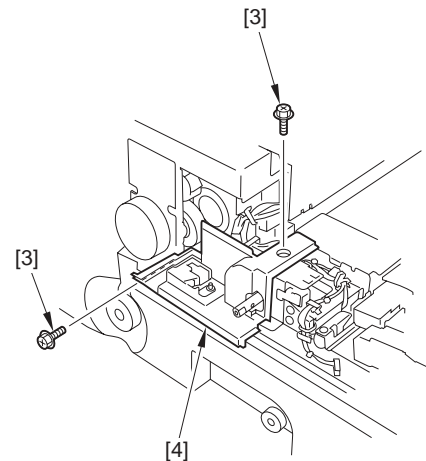

F-10-28

**10.5.1.12 Fixing Cover (Upper)**

**10.5.1.12.1 Removing the Fixing Upper Cover**

iR5065 / iR 5055 / iR5075 / iR5075N / iR5065N / iR5055N

0015-9419

- 1) Open the front cover [1].

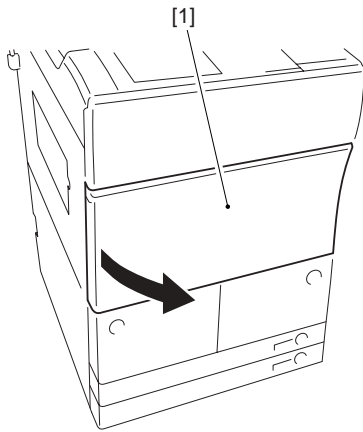

F-10-29

2) Turn the fixing/feeding unit releasing lever [1] counterclockwise to unlock. Hold the lever [1] to slide out the fixing/feeding unit [2] fully. (The duplexing feed unit will also be slid out.)

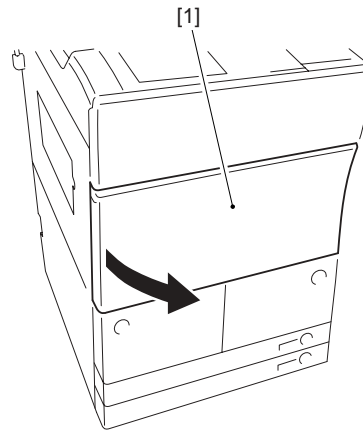

F-10-32

2) Turn the fixing/feeding unit releasing lever [1] counterclockwise to unlock. Hold the lever [1] to slide out the fixing/feeding unit [2] fully. (The duplexing feed unit will also be slid out.)

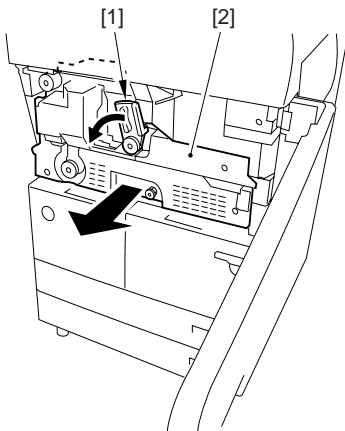

F-10-30

3) Open the delivery unit [1] and detach the fixing upper cover [3].  
- 1 screw [2]

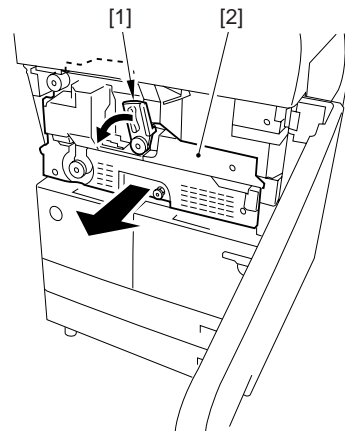

F-10-33

3) While pushing the rear hook shaft [1] of the fixing/feeding unit in the direction of the arrow (to the machine's front), turn the fixing/feeding unit releasing lever [2] clockwise to lock.

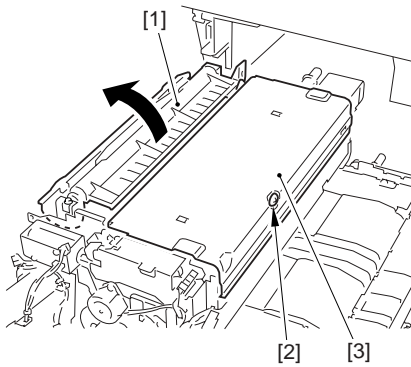

F-10-31

### 10.5.1.13 Fixing Cover (Lower)

#### 10.5.1.13.1 Removing the Fixing Front Cover

iR5065 / iR 5055 / iR5075 / iR5075N / iR5065N / iR5055N

1) Open the front cover [1].

0015-9418

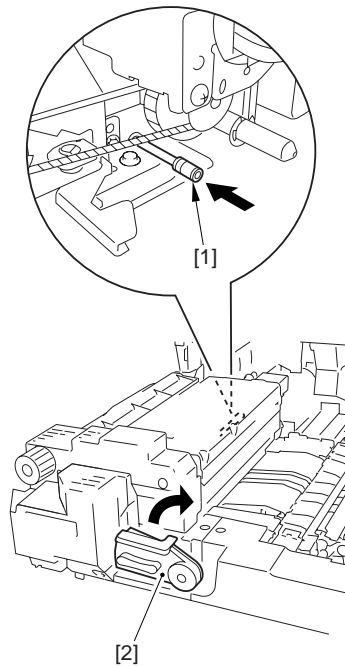

F-10-34

4) Remove the knob [2] and the fixing/feeding unit releasing lever [4].  
- 2 screws [1,3]

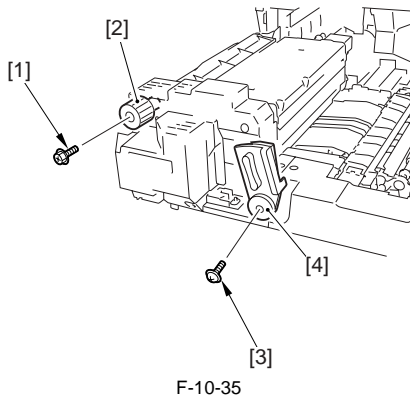

5) Detach the fixing front cover [2].  
- 2 screws [1]

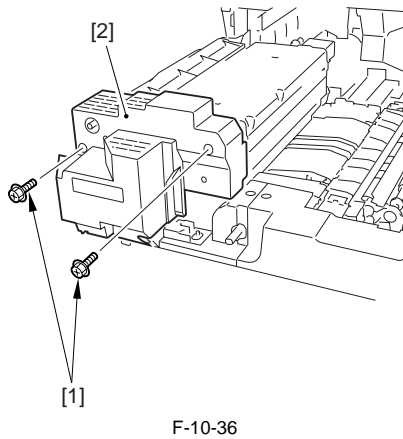

**10.5.1.14 Main Controller Box Cover**

**10.5.1.14.1 Before Removing the Main Controller Box Cover**

iR5065 / iR 5055 / iR5075 / iR5075N / iR5065N / iR5055N [0015-8310](#)

1) Detach the rear cover (upper). (page 10-13)Reference[Removing the Rear Cover (Upper)]

**10.5.1.14.2 Removing the Main Controller Box Cover**

iR5065 / iR 5055 / iR5075 / iR5075N / iR5065N / iR5055N [0015-6690](#)

1) Detach the main controller box cover [2].  
- 4 screws [1]

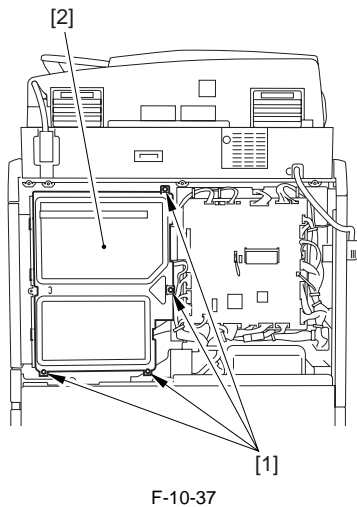

**10.5.1.15 Reader Left Cover**

**10.5.1.15.1 Removing the Reader Left Cover**

iR5065 / iR 5055 / iR5075 / iR5075N / iR5065N / iR5055N [0015-6685](#)

1) Detach the reader left cover [2].  
- 2 screws [1]

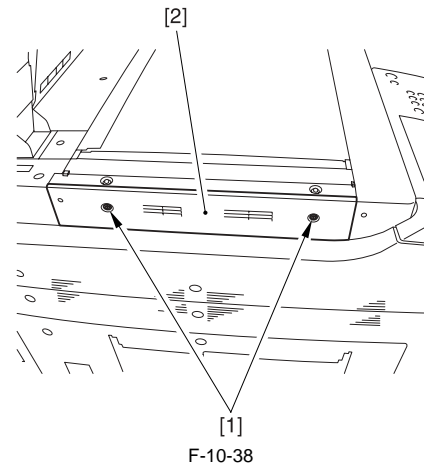

**10.5.1.16 Reader Right Cover**

**10.5.1.16.1 Removing the Reader Right Cover**

iR5065 / iR 5055 / iR5075 / iR5075N / iR5065N / iR5055N [0015-6684](#)

1) Detach the reader right cover [2].  
- 2 screws [1]

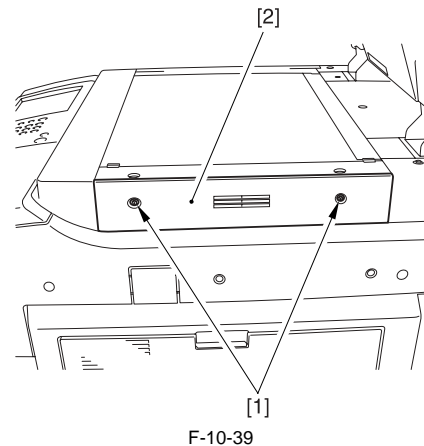

**10.5.1.17 Reader Front Cover**

**10.5.1.17.1 Before Detaching the Reader Front Cover**

iR5065 / iR 5055 / iR5075 / iR5075N / iR5065N / iR5055N [0015-8312](#)

- 1) Detach the right cover (upper). (page 10-12)Reference[Removing the Right Cover (Upper)]
- 2) Detach the left cover (upper). (page 10-12)Reference[Removing the Left Cover (Upper)]

**10.5.1.17.2 Detaching the Reader Front Cover**

iR5065 / iR 5055 / iR5075 / iR5075N / iR5065N / iR5055N [0015-6686](#)

1) Remove the each screw [1] from the reader front cover [2] right and left.

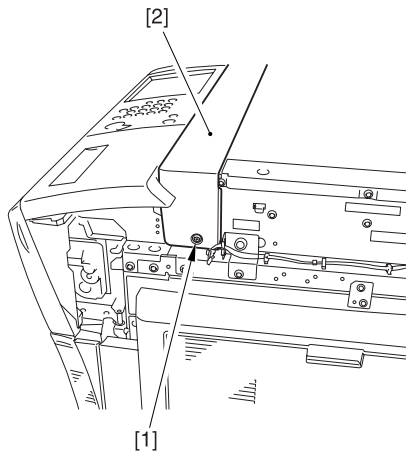

F-10-40

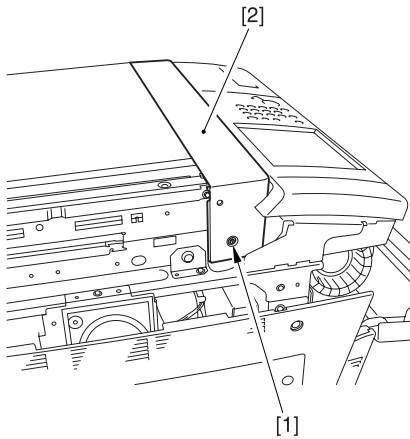

F-10-41

2) Lift the reader front cover and detach [1].

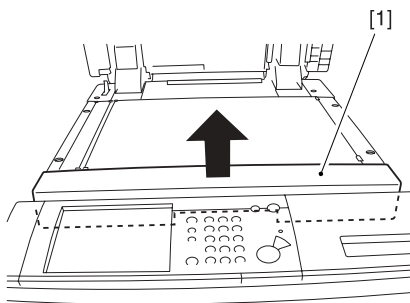

F-10-42

### 10.5.1.18 Reader Rear Cover

#### 10.5.1.18.1 Detaching the Reader Rear Cover

iR5065 / iR 5055 / iR5075 / iR5075N / iR5065N / iR5055N

- 1) Open the cable clamp [1].
- 2) Disconnect the 4 connectors [2].
- 3) Remove the 2 screws [3].

0015-6687

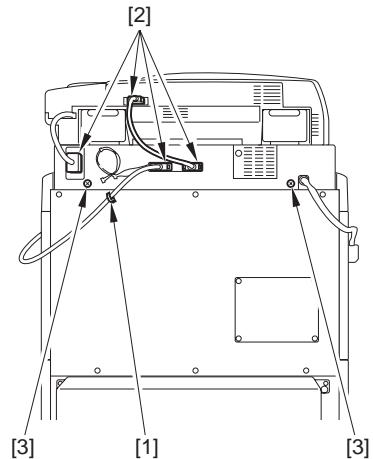

F-10-43

4) Bend up the rubber cover [1], and remove the 2 screws [2] each; then detach the 2 angle guide plates [3].

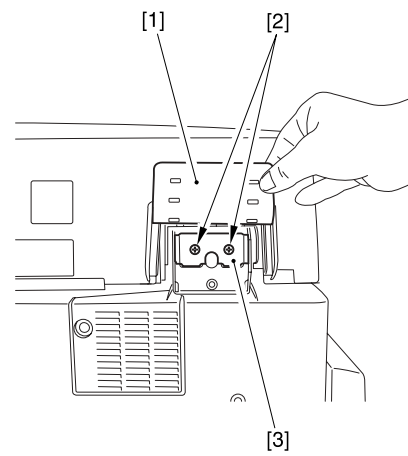

F-10-44

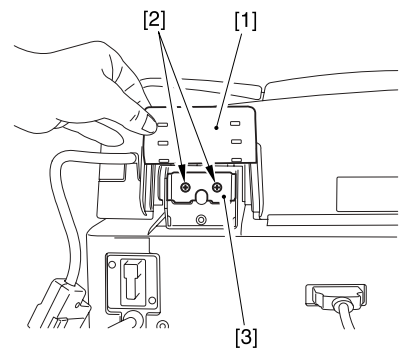

F-10-45

- 5) Fully open the ADF.
- 6) Slide the reader rear cover [2] to the rear to detach.  
- 3 screws [1]



Be careful not to damage the ADF open/close sensor arm [3].



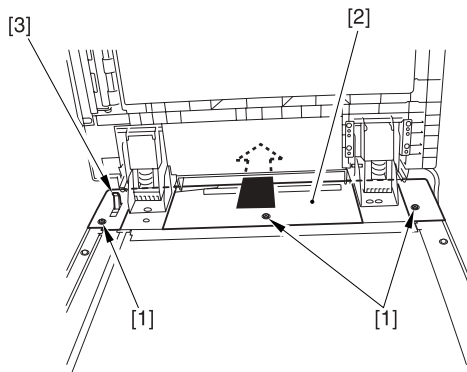

F-10-46

## 10.5.2 Left Deck Drive Assembly

### 10.5.2.1 Before Removing the Left Deck Drive Assembly

iR5065 / iR 5055 / iR5075 / iR5075N / iR5065N / iR5055N

- 1) Remove the charger unit (this step is necessary only for iR5075 for Japan). (page 10-22)Reference[Removing the Charger unit]
- 2) Remove the rear cover (upper). (page 10-13)Reference[Removing the Rear Cover (Upper)]
- 3) Detach the rear cover (lower). (page 10-13)Reference[Removing the Rear Cover (Lower)]
- 4) Remove the HVT PCB. (page 10-28)Reference[Removing HVT PCB]

### 10.5.2.2 Removing the Left Deck Drive Assembly

iR5065 / iR 5055 / iR5075 / iR5075N / iR5065N / iR5055N

- 1) Detach the left deck drive assembly [4].
  - 4 screws [1]
  - 1 connector [2]
  - 2 wire saddles [3] (Free the harness)

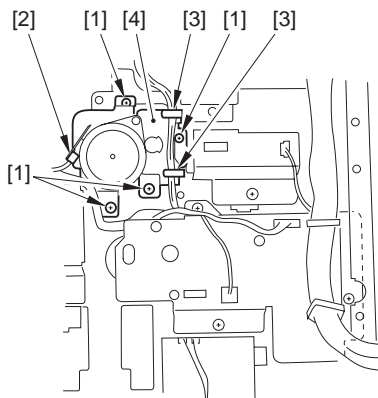

F-10-47

## 10.5.3 Manual Feed Pickup Drive Assembly

### 10.5.3.1 Before Removing the Manual Pickup Drive Assembly

iR5065 / iR 5055 / iR5075 / iR5075N / iR5065N / iR5055N

- 1) Remove the charger unit (this step is necessary only for iR5075 for Japan). (page 10-22)Reference[Removing the Charger unit]
- 2) Remove the rear cover (upper). (page 10-13)Reference[Removing the Rear Cover (Upper)]
- 3) Remove the rear cover (lower). (page 10-13)Reference[Removing the Rear Cover (Lower)]
- 4) Remove the main controller box cover. (page 10-17)Reference[Removing the Main Controller Box Cover]
- 5) Remove the right cover (upper rear). (page 10-12)Reference[Removing the Right Cover (Upper Rear)]
- 6) Remove the main controller box. (page 4-13)Reference[Removing the Main Controller Box]
- 7) Remove the separation claw AC PCB unit. (page 10-28)Reference[Removing Separation Claw AC PCB]

### 10.5.3.2 Removing the Manual Pickup Drive Assembly

iR5065 / iR 5055 / iR5075 / iR5075N / iR5065N / iR5055N

- 1) Remove the scanner fan duct [2].
  - 2 screws [1]



Before removing the screw, make sure to mark the line in the following step.

- 2) Loosen the screw [3] to release the belt tensioner [4], and detach the belt [5].

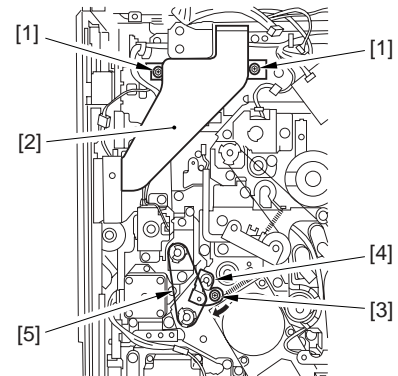

F-10-48

- 3) Remove the pickup drive assembly [3].
  - 4 screws [1]
  - 3 connectors [2]

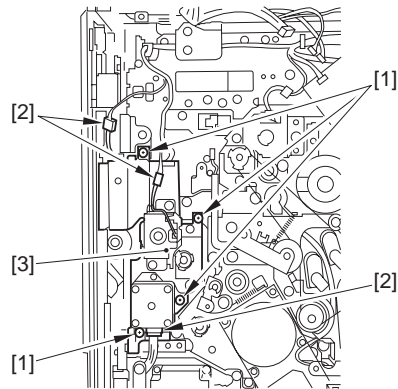

F-10-49

## 10.5.4 Vertical Path Drive Assembly

### 10.5.4.1 Before Removing the Vertical Path Drive Assembly

iR5065 / iR 5055 / iR5075 / iR5075N / iR5065N / iR5055N

- 1) Remove the charger unit (this step is necessary only for iR5075 for Japan). (page 10-22)Reference[Removing the Charger unit]
- 2) Remove the rear cover (upper). (page 10-13)Reference[Removing the Rear Cover (Upper)]
- 3) Detach the rear cover (lower). (page 10-13)Reference[Removing the Rear Cover (Lower)]
- 4) Detach the main controller box cover. (page 10-17)Reference[Removing the Main Controller Box Cover]
- 5) Removing the Right Cover (Upper Rear). (page 10-12)Reference[Removing the Right Cover (Upper Rear)]
- 6) Remove the main controller box. (page 4-13)Reference[Removing the Main Controller Box]
- 7) Detach the right cover (lower rear). (page 10-12)Reference[Removing the Right Cover (Lower Rear)]
- 8) Remove the collecting toner bottle holder. (page 5-29)Reference[Removing the Collecting Toner Bottle Holder]

### 10.5.4.2 Removing the Vertical Path Drive Assembly

iR5065 / iR 5055 / iR5075 / iR5075N / iR5065N / iR5055N

- 1) Disconnect the 10 connectors on the motor driver PCB .
- 2) Detach the motor driver PCB mounting base [3].
  - 9 wire saddles (Free the harness [1])
  - 4 screws [2]

### 10.5.5.2 Removing the Collecting Toner Drive Assembly

iR5065 / iR 5055 / iR5075 / iR5075N / iR5065N / iR5055N

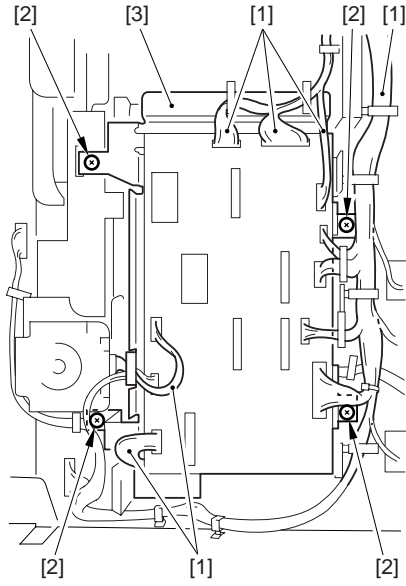

F-10-50

- 3) Remove the vertical path drive assembly [3].
  - 3 screws [1]
  - 1 wire saddle [2] (Free the harness)

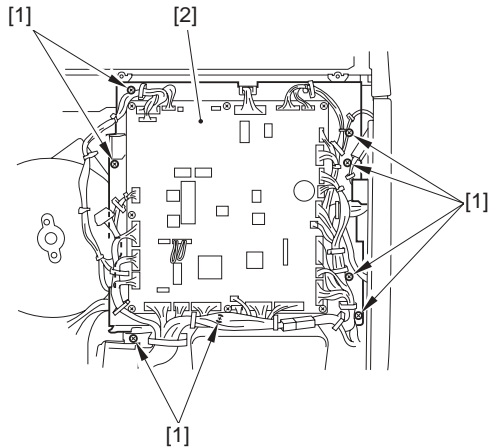

F-10-52

- 1) Disconnect all of the connectors on the DC controller PCB.
- 2) Pull out the DC controller mounting base [2], and turn it over.
  - 14 wire saddles (Free the harness)
  - 1 edge saddle (Free the harness)
  - 1 reuse band
  - 8 screws [1] (Free the grounding wire)
- 3) Remove the DC controller mounting base [6].
  - 3 connectors [1]
  - 2 wire saddles [2] (Free the harness [3])
  - 1 edge saddle [4] (Free the harness [5])

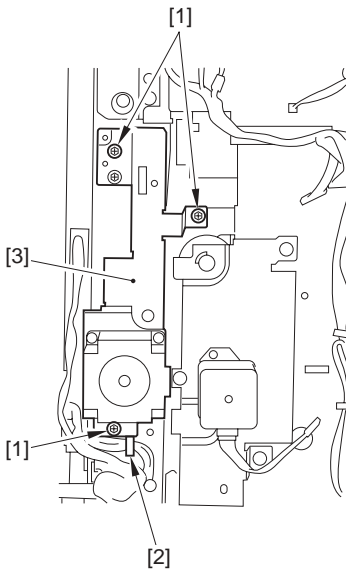

F-10-51

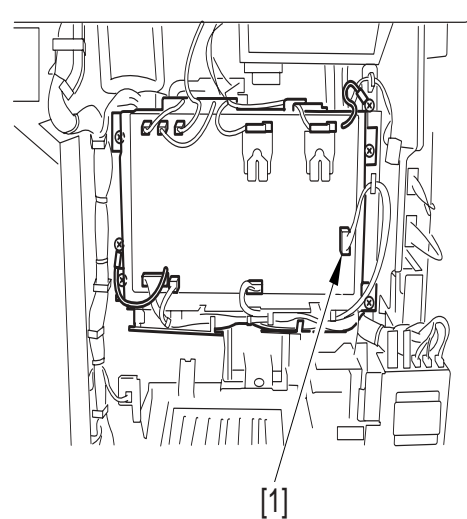

F-10-53

- 4) Remove the flywheel [2].
  - 2 screws [1]

### 10.5.5 Waste Toner Drive Assembly

#### 10.5.5.1 Before Removing the Collecting Toner Drive Assembly

iR5065 / iR 5055 / iR5075 / iR5075N / iR5065N / iR5055N

- 1) Remove the charger unit (this step is necessary only for iR5075 for Japan). (page 10-22)Reference[Removing the Charger unit]
- 2) Remove the rear cover (upper). (page 10-13)Reference[Removing the Rear Cover (Upper)]
- 3) Detach the rear cover (lower). (page 10-13)Reference[Removing the Rear Cover (Lower)]
- 4) Detach the main controller box cover. (page 10-17)Reference[Removing the Main Controller Box Cover]
- 5) Removing the right cover (upper rear). (page 10-12)Reference[Removing the Right Cover (Upper Rear)]
- 6) Remove the main controller box. (page 4-13)Reference[Removing the Main Controller Box]
- 7) Detach the right cover (lower rear). (page 10-12)Reference[Removing the Right Cover (Lower Rear)]
- 8) Remove the collecting toner bottle holder. (page 5-29)Reference[Removing the Collecting Toner Bottle Holder]

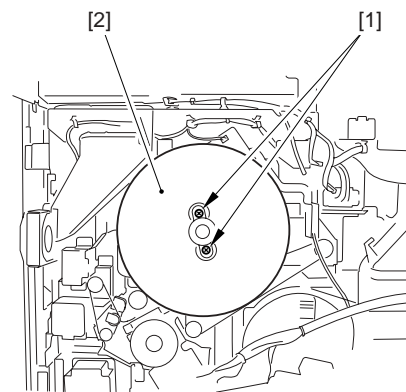

F-10-54

- 5) Loosen the belt tensioner [1] to detach the main motor belt [2].

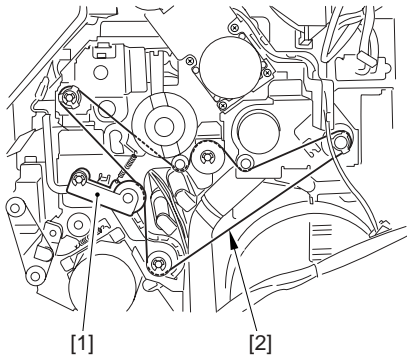

F-10-55

- 6) Remove the collecting toner drive assembly [2].  
- 3 screws [1]

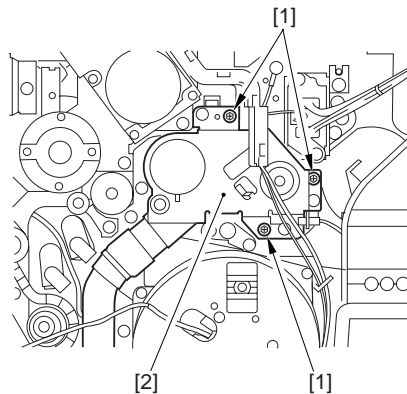

F-10-56

## 10.5.6 Main Drive Assembly

### 10.5.6.1 Fitting the Drive Belt

iR5065 / iR 5055 / iR5075 / iR5075N / iR5065N / iR5055N

Be sure that the drive belt is fitted to the pulley and the roller as shown in the following figure.

- [1] Main drive belt  
[2] Pickup drive belt

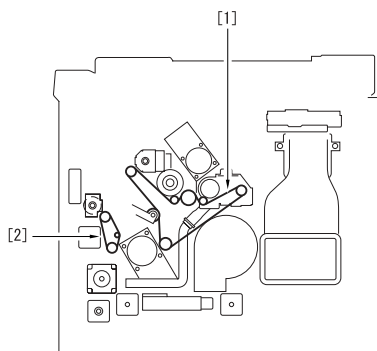

F-10-57

## 10.5.7 Cassette Pickup Drive Assembly

### 10.5.7.1 Before Removing the Cassette Pickup Drive Assembly

iR5065 / iR 5055 / iR5075 / iR5075N / iR5065N / iR5055N

- 1) Remove the charger unit (this step is necessary only for iR5075 for Japan).  
(page 10-22)Reference[Removing the Charger unit]
- 2) Remove the rear cover (upper). (page 10-13)Reference[Removing the Rear Cover (Upper)]
- 3) Detach the rear cover (lower). (page 10-13)Reference[Removing the Rear Cover (Lower)]
- 4) Detach the main controller box cover. (page 10-17)Reference[Removing the Main Controller Box Cover]
- 5) Removing the Right Cover (Upper Rear). (page 10-12)Reference[Removing the Right Cover (Upper Rear)]
- 6) Remove the main controller box. (page 4-13)Reference[Removing the

Main Controller Box]

- 7) Detach the right cover (lower rear). (page 10-12)Reference[Removing the Right Cover (Lower Rear)]
- 8) Remove the collecting toner bottle holder. (page 5-29)Reference[Removing the Collecting Toner Bottle Holder]

### 10.5.7.2 Removing the Cassette Pickup Drive Assembly

iR5065 / iR 5055 / iR5075 / iR5075N / iR5065N / iR5055N

- 1) Disconnect the 10 connectors on the motor driver PCB.
- 2) Remove the motor driver PCB mounting base [3].  
- 9 wire saddles (Free the harness [1])  
- 4 screws [2]

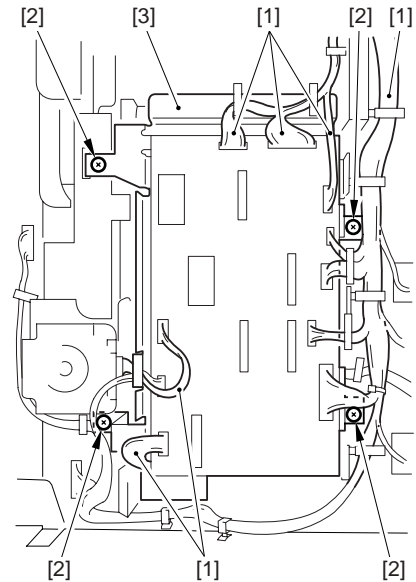

F-10-58



- The removal procedure of the right deck pickup assembly and the cassette 3/4 pickup assembly is the same.
- An illustration uses a right door pickup assembly as an example to explain.
- An attempt removing the pickup assembly without removing the deck/cassette causes the lifter get trapped and may hold the pickup assembly from sliding out.

- 3) Slide out the cassette 3 and the cassette 4.
- 4) Open the manual tray cover and the right cover (lower).
- 5) Disconnect the connector [3].  
- 1 screw [1]  
- 1 connector cover [2]
- 6) Remove the pickup assembly [5].  
- 3 screws [4]

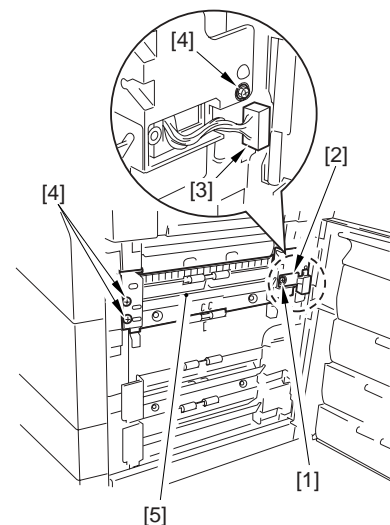

F-10-59

- 7) Remove the cassette pickup drive assembly [2].  
- 3 screws [1]

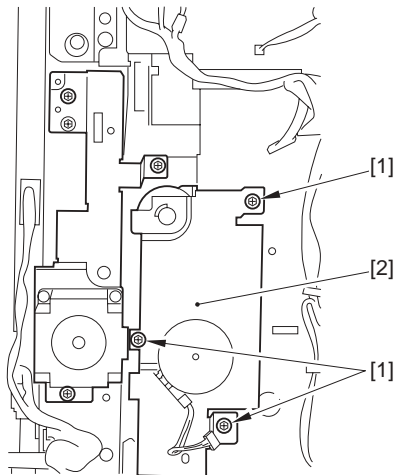

F-10-60

**10.5.8 Fixing Drive Assembly**

**10.5.8.1 Before Removing the Fixing Drive Assembly**

iR5065 / iR 5055 / iR5075 / iR5075N / iR5065N / iR5055N

- 1) Detach the fixing front cover. (page 10-16)Reference[Removing the Fixing Front Cover]

**10.5.8.2 Removing the Fixing Drive Assembly**

iR5065 / iR 5055 / iR5075 / iR5075N / iR5065N / iR5055N

- 1) Remove the fixing drive assembly [3].
  - 2 connectors [1]
  - 3 screws [2]

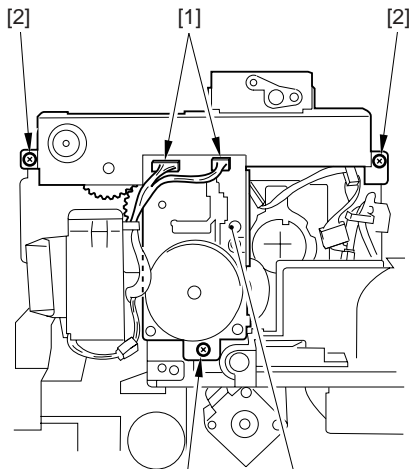

F-10-61

**10.5.9 Power Supply Unit**

**10.5.9.1 Removing the Charger unit**

iR5065 / iR 5055 / iR5075 / iR5075N / iR5065N / iR5055N

- 1) Remove the charger unit [3].
  - 1 Connector [1]
  - 5 Screw [2]

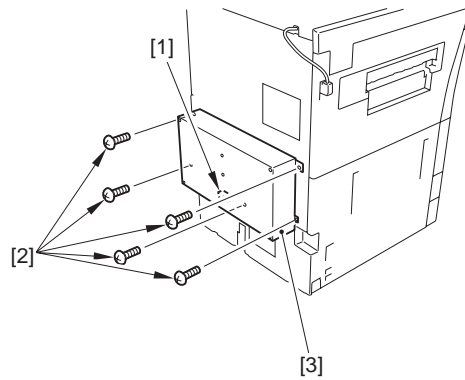

F-10-62

T-10-19



**10.5.9.2 Points to Note At Occurrence of Charger unit Malfunction**

iR5065 / iR 5055 / iR5075 / iR5075N / iR5065N / iR5055N

- E732 error may indicate the malfunction of the charger unit. In this case, perform the following after removing the charger unit.
- 1) Open the wire saddle [1] and disconnect the connector [2] of the reader unit communication cable.

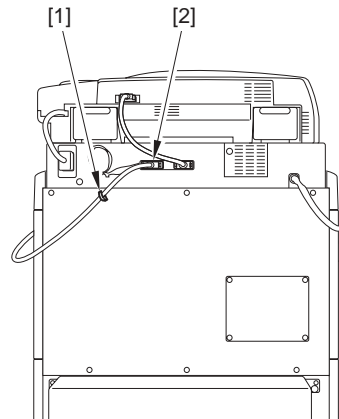

F-10-63

- 2) Detach the rear cover (upper) [2].
  - 6 screws [1]

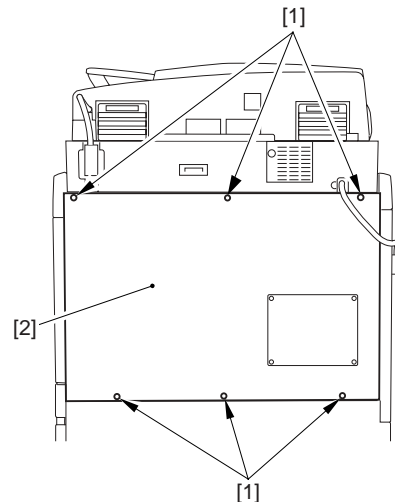

F-10-64

- 3) Detach the rear cover (lower) [2].
  - 8 Screw [1]

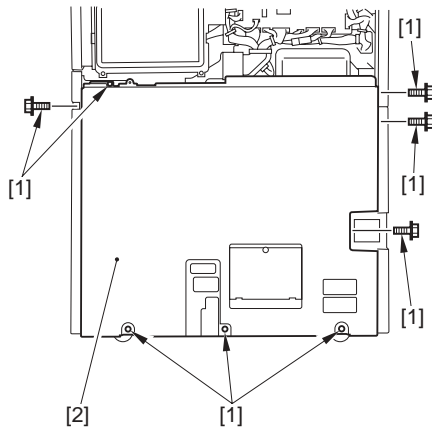

F-10-65

- 4) Disconnect the connector [1] of the auxiliary power and connect the jumper connector [2].

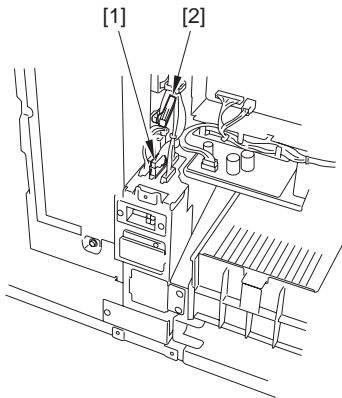

F-10-66

- 5) Once the main power is turned on, the following message is displayed on the control panel.  
 "Time for maintenance work.  
 The capacitor needs checking. Please call the service personnel.  
 You can continue to use the machine, however, the operational speed during printing may be slower than usual"  
 6) Once pressing "Close" button, a message, "The capacitor needs checking (Please call the service personnel)", is displayed at the bottom on the control panel.

This is a temporary measure. Be sure to replace with the new one once you receive the Power Accumulating Unit.

T-10-20



This step enables direct power supply from the auxiliary power to the reader/DADF. Therefore, the speed of continuous print after power-on (for approx. 15 min) becomes shorter.

## 10.5.10 Duplex Unit PCB

### 10.5.10.1 Before Removing the Duplex unit PCB

iR5065 / iR 5055 / iR5075 / iR5075N / iR5065N / iR5055N

- 1) Detach the duplexing feed front cover. (page 10-14)Reference[Removing the Duplexing Feed Front Cover]
- 2) Remove the duplex feeding unit. (page 8-49)Reference[Removing the Duplex Feeding Unit]

### 10.5.10.2 Removing the Duplex Unit PCB

iR5065 / iR 5055 / iR5075 / iR5075N / iR5065N / iR5055N

- 1) Remove the duplex unit PCB [3].  
- 4 screws [1]

- 6 connectors [2]

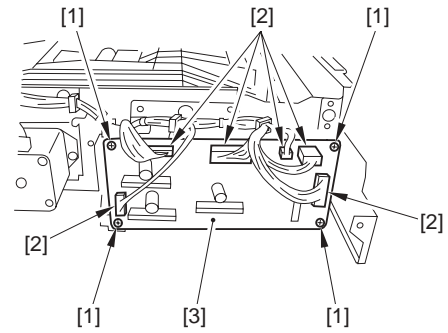

F-10-67

## 10.5.11 Control Panel

### 10.5.11.1 Before Removing Control Panel

iR5065 / iR 5055 / iR5075 / iR5075N / iR5065N / iR5055N

- 1) Detach the right cover (upper). (page 10-12)Reference[Removing the Right Cover (Upper)]
- 2) Detach the reader right cover. (page 10-17)Reference[Removing the Reader Right Cover]
- 3) Detach the left cover (upper). (page 10-12)Reference[Removing the Left Cover (Upper)]
- 4) Detach the reader left cover. (page 10-17)Reference[Removing the Reader Left Cover]
- 5) Detach the reader front cover. (page 10-17)Reference[Detaching the Reader Front Cover]

### 10.5.11.2 Removing Control Panel

iR5065 / iR 5055 / iR5075 / iR5075N / iR5065N / iR5055N

- 1) Open the hopper front cover.
- 2) Remove the 5 screws [1] at right, left, rear of the control panel [2].

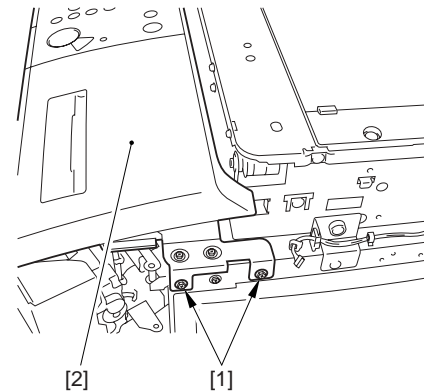

F-10-68

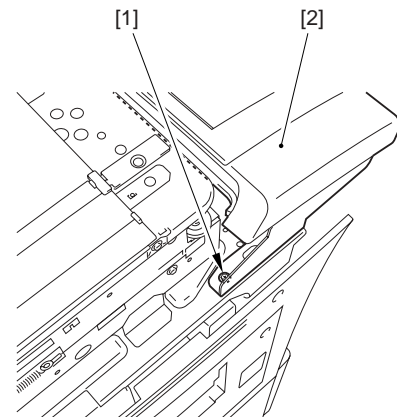

F-10-69

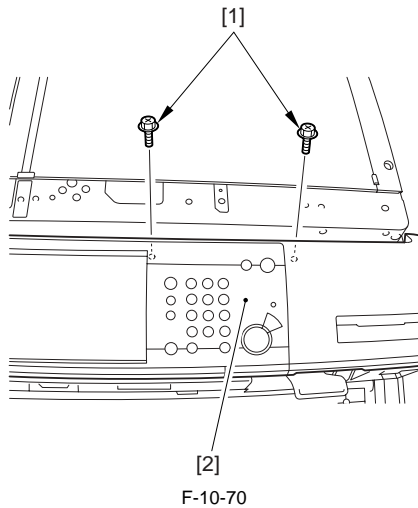

- 3) Shift the control panel [3] together with the cover, and remove the use band [1] and disconnect the connector [2]. Then, remove the control panel [3].

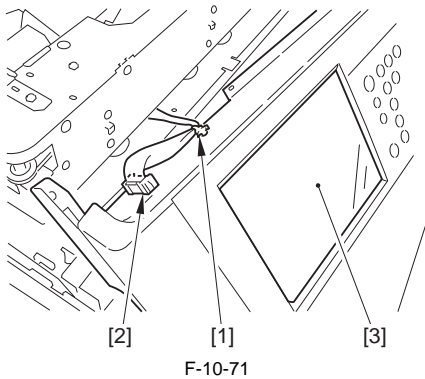

**10.5.12 DC Controller PCB**

**10.5.12.1 Before Removing DC Controller PCB**

iR5065 / iR 5055 / iR5075 / iR5075N / iR5065N / iR5055N

- 1) Detach the rear cover (upper). (page 10-13)Reference[Removing the Rear Cover (Upper)]

**10.5.12.2 Removing DC Controller PCB**

iR5065 / iR 5055 / iR5075 / iR5075N / iR5065N / iR5055N

- 1) Remove the DC controller-PCB [2].  
 - 28 connectors  
 - 8 screws [1]

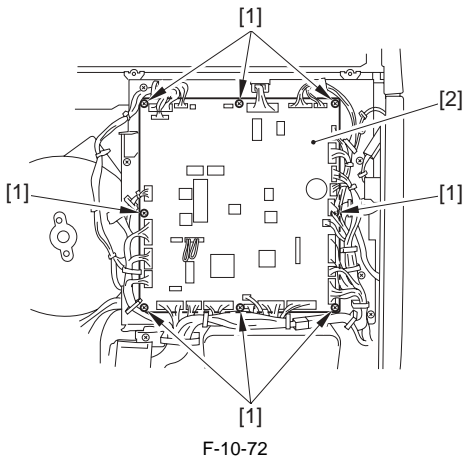

**10.5.12.3 When Replacing DC Controller PCB**

iR5065 / iR 5055 / iR5075 / iR5075N / iR5065N / iR5055N

Be sure to perform the followings when replacing the DC controller PCB.

- 1) Enter the latest values for the service mode indicated on the label [1] on the back of the front cover with the service mode.
- 2) Enter the values indicated on the label [1] of the new PCB using the following service mode items:  
 COPIER> ADJUST> HV-TR> D-PRE-TR  
 COPIER> ADJUST> HV-TR> D-HV-TR  
 COPIER> ADJUST> HV-SP> D-HV-SP  
 COPIER> ADJUST> DEVELOP> D-HV-DE
- 3) Move the J303 shorting connector [2] on the PCB from the existing to the new PCB.



Make sure to connect the shorting connector. Otherwise, E004 occurs.

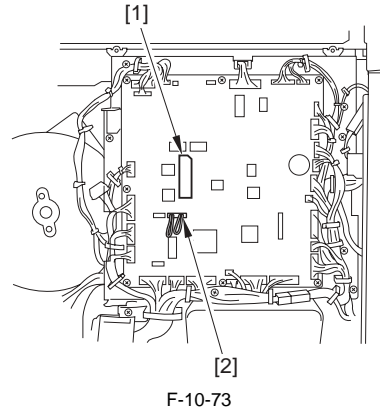

**10.5.13 Printer Power Supply PCB**

**10.5.13.1 Before Removing Printer Power Supply PCB**

iR5065 / iR 5055 / iR5075 / iR5075N / iR5065N / iR5055N

- 1) Detach the left cover (upper). (page 10-12)Reference[Removing the Left Cover (Upper)]
- 2) Detach the left cover (middle). (page 10-14)Reference[Removing the Left Cover (Middle)]
- 3) Detach the left cover (lower). (page 10-13)Reference[Removing the Left Cover (Lower)]

**10.5.13.2 Removing Printer Power Supply PCB**

iR5065 / iR 5055 / iR5075 / iR5075N / iR5065N / iR5055N

- 1) Detach the shield plate [2].  
 - 4 screws [1]

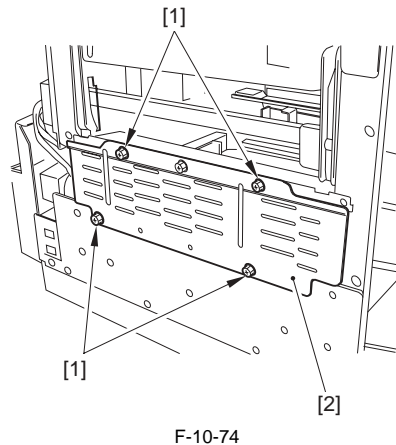

- 2) Detach the power supply cover [2].  
 - 9 screws [1]

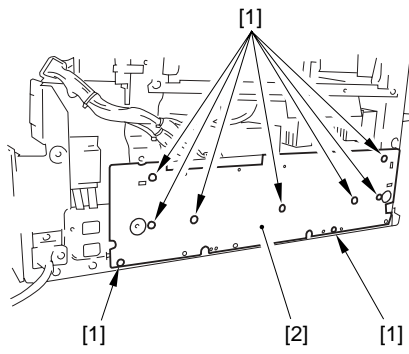

F-10-75

- 3) Remove the printer power supply PCB [2].  
 - 14 connectors  
 - 2 screws [1]

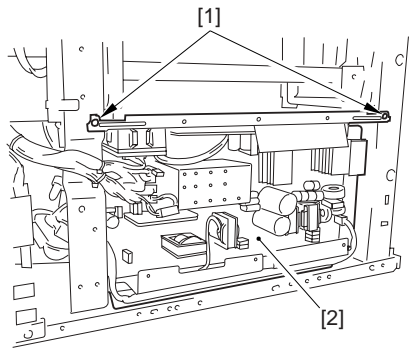

F-10-76

#### 10.5.14 Option Power Supply PCB

##### 10.5.14.1 Before Removing Accessories Power Supply PCB

iR5065 / iR 5055 / iR5075 / iR5075N / iR5065N / iR5055N

- 1) Remove the charger unit (this step is necessary only for iR5075 for Japan).  
 (page 10-22)Reference[Removing the Charger unit]
- 2) Remove the rear cover (upper). (page 10-13)Reference[Removing the Rear Cover (Upper)]
- 3) Detach the rear cover (lower). (page 10-13)Reference[Removing the Rear Cover (Lower)]
- 4) Detach the left cover (upper). (page 10-12)Reference[Removing the Left Cover (Upper)]
- 5) Detach the left cover (middle). (page 10-14)Reference[Removing the Left Cover (Middle)]
- 6) Detach the left cover (lower). (page 10-13)Reference[Removing the Left Cover (Lower)]

##### 10.5.14.2 Removing Accessories Power Supply PCB

iR5065 / iR 5055 / iR5075 / iR5075N / iR5065N / iR5055N

- 1) Slide the power cord mount [4].  
 - 5 screws [1]  
 - 5 connectors [2]  
 - 1 edge saddle [3] (free the harness)

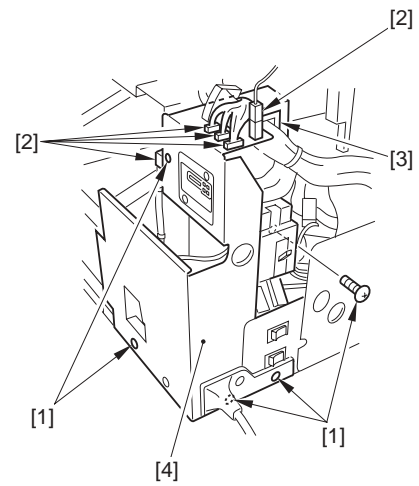

F-10-77

- 2) Remove the power cord mount [2].  
 - 3 connectors [1]

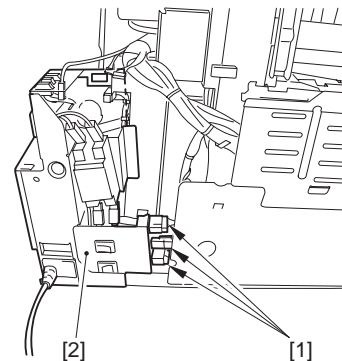

F-10-78

- 3) Remove the accessories power supply PCB [3].  
 - 3 screws [1]  
 - 3 connectors [2]

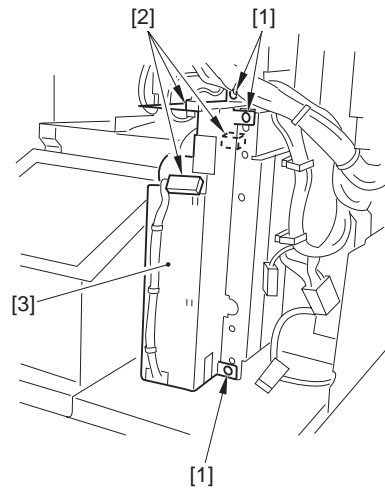

F-10-79

#### 10.5.15 Fixing Heater Power Supply PCB

##### 10.5.15.1 Before Removing Fixing Heater Power Supply PCB

iR5065 / iR 5055 / iR5075 / iR5075N / iR5065N / iR5055N

- 1) Detach the left cover (upper). (page 10-12)Reference[Removing the Left Cover (Upper)]
- 2) Detach the left cover (middle). (page 10-14)Reference[Removing the Left Cover (Middle)]

##### 10.5.15.2 Removing Fixing Heater Power Supply PCB

iR5065 / iR 5055 / iR5075 / iR5075N / iR5065N / iR5055N

- 1) Detach the mount cover [2].  
- 5 screws [1]

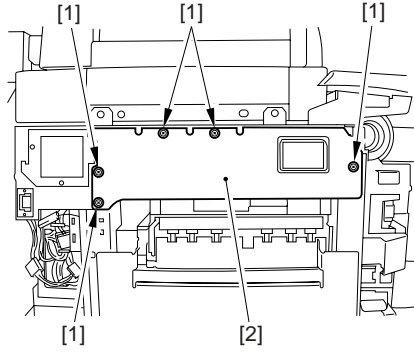

F-10-80

- 2) Open the 2 wire saddles [1].
- 3) Disconnect the 7 connectors [2].
- 4) Remove the fixing heater power supply unit [4].  
- 3 screws [3]

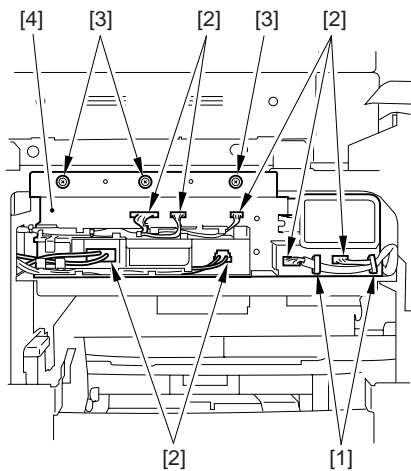

F-10-81

- 5) Detach the fixing heater power supply unit cover [2].  
- 14 screws [1]

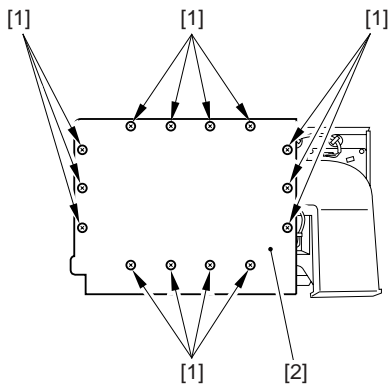

F-10-82

- 6) Remove the 2 reuse bands [2].  
- 2 connectors [1]
- 7) Remove the fixing heater power supply PCB [4].  
- 6 screws [3]

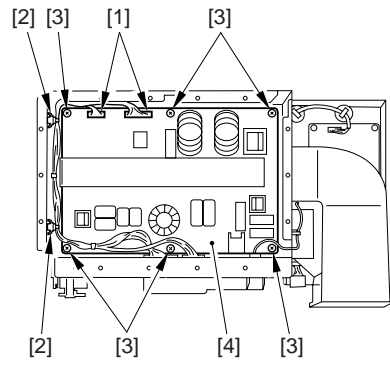

F-10-83

## 10.5.16 Anti-Rush Current PCB

### 10.5.16.1 Before Removing Anti-Rush Current PCB

iR5065 / iR 5055 / iR5075 / iR5075N / iR5065N / iR5055N

- 1) Detach the rear cover (upper). (page 10-13)Reference[Removing the Rear Cover (Upper)]

### 10.5.16.2 Removing Anti-Rush Current PCB

iR5065 / iR 5055 / iR5075 / iR5075N / iR5065N / iR5055N

- 1) Disconnect all connectors on the DC controller PCB.
- 2) Remove the DC controller PCB mount [2] and turn it over.
  - 14 wire saddles (free the harness)
  - 1 edge saddle (free the harness)
  - 1 reuse band
  - 8 screws [1] (free the grounding wire)

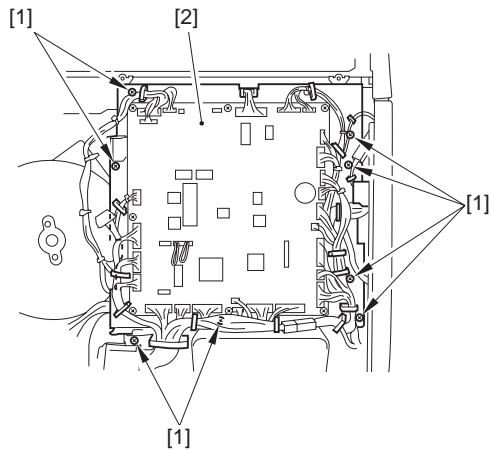

F-10-84

- 3) Remove the anti-rush current PCB [4].
  - 3 connectors [1]
  - 3 PCB supports [3]
  - 1 screw [2]



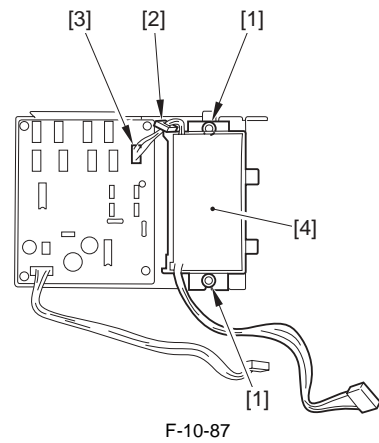
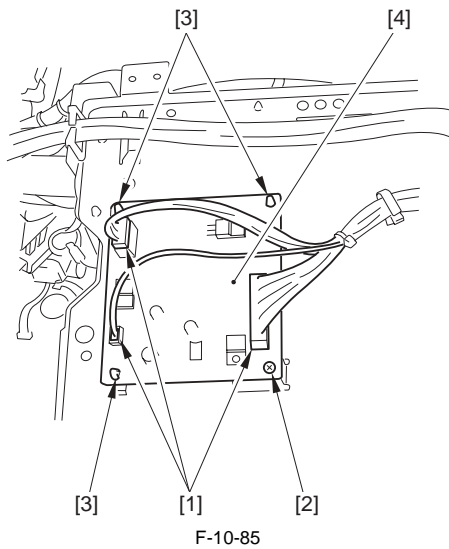

### 10.5.17 High-Voltage Transformer (AC)

#### 10.5.17.1 Before Removing High Voltage Transformer

iR5065 / iR 5055 / iR5075 / iR5075N / iR5065N / iR5055N

- 1) Remove the charger unit (this step is necessary only for iR5075 for Japan). (page 10-22)Reference[Removing the Charger unit]
- 2) Remove the rear cover (upper). (page 10-13)Reference[Removing the Rear Cover (Upper)]
- 3) Detach the rear cover (lower). (page 10-13)Reference[Removing the Rear Cover (Lower)]

#### 10.5.17.2 Removing High Voltage Transformer

iR5075 / iR5075N

- 1) Remove the transformer unit [3] by sliding it to the left.
  - 2 screws [1]
  - 3 connectors [2]

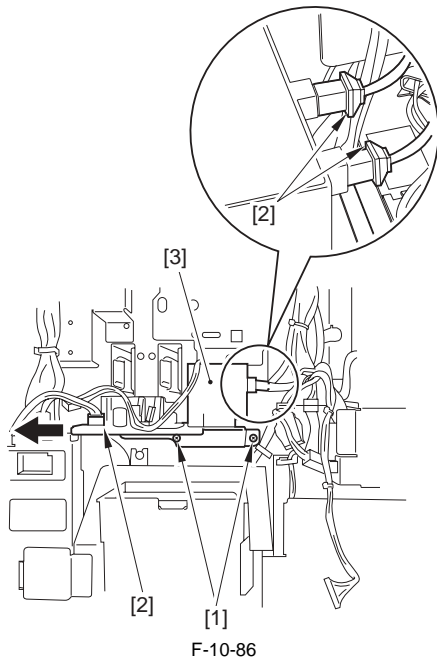

- 2) Remove the transformer [4].
  - 2 screws [1]
  - 1 wire saddle [2]
  - 1 connector [3]

#### 10.5.17.3 Removing High Voltage Transformer

iR5065 / iR 5055 / iR5065N / iR5055N

- 1) Remove the transformer unit [3] by sliding it to the left.
  - 2 screws [1]
  - 2 connectors [2]

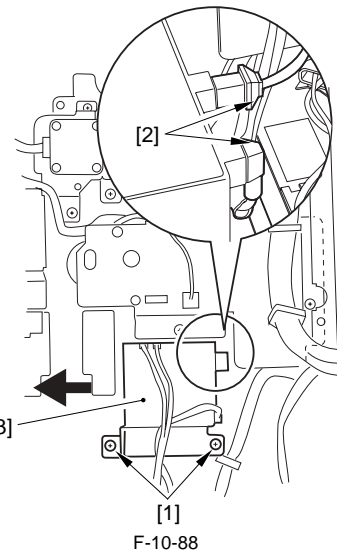

- 2) Remove one connector [1] on the HVT PCB.

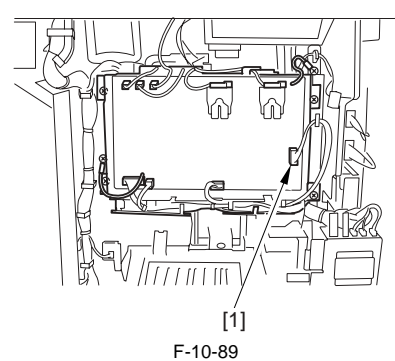

- 3) Remove the transformer [2].
  - 2 screws [1]

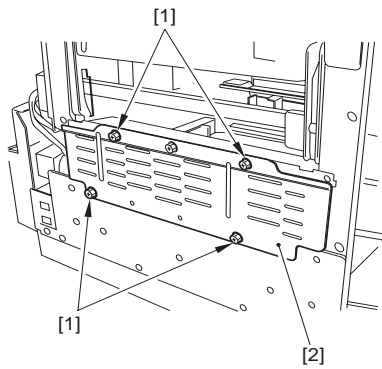

F-10-90

## 10.5.18 HVT PCB

### 10.5.18.1 Before Removing HVT PCB

iR5065 / iR 5055 / iR5075 / iR5075N / iR5065N / iR5055N

- 1) Remove the charger unit (this step is necessary only for iR5075 for Japan). (page 10-22)Reference[Removing the Charger unit]
- 2) Remove the rear cover (upper). (page 10-13)Reference[Removing the Rear Cover (Upper)]
- 3) Detach the rear cover (lower). (page 10-13)Reference[Removing the Rear Cover (Lower)]

### 10.5.18.2 Removing HVT PCB

iR5065 / iR 5055 / iR5075 / iR5075N / iR5065N / iR5055N

- 1) Remove the grounding wire [2].  
- 1 screw [1]
- 2) Disconnect the 9 connectors [3].
- 3) Remove the HVT PCB [5].  
- 4 screws [4]

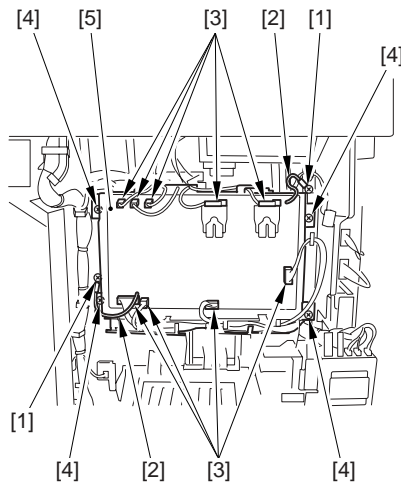

F-10-91

### 10.5.18.3 When Replacing HVT PCB

iR5065 / iR 5055 / iR5075 / iR5075N / iR5065N / iR5055N

Enter the values indicated on the label of the HVT PCB using the following service mode items:

```
COPIER>ADJUST>HV-TR>H-PRE-TR
COPIER>ADJUST>HV-TR>HVT-TR
COPIER>ADJUST>HV-SP>HVT-SP
COPIER>ADJUST>DEVELOP>HVT-DE
```

## 10.5.19 Separation Claw AC bias PCB

### 10.5.19.1 Before Removing Separation Claw AC PCB

iR5065 / iR 5055 / iR5075 / iR5075N / iR5065N / iR5055N

- 1) Detach the rear cover (upper). (page 10-13)Reference[Removing the Rear Cover (Upper)]
- 2) Detach the main controller box cover. (page 10-17)Reference[Removing the Main Controller Box Cover]
- 3) Detach the right cover (upper rear). (page 10-12)Reference[Removing the Right Cover (Upper Rear)]

- 4) Remove the main controller box. (page 4-13)Reference[Removing the Main Controller Box]

### 10.5.19.2 Removing Separation Claw AC PCB

iR5065 / iR 5055 / iR5075 / iR5075N / iR5065N / iR5055N

- 1) Remove the separation claw AC PCB unit [3].  
- 1 connector [1]  
- 2 screws [2] (free the grounding wire)

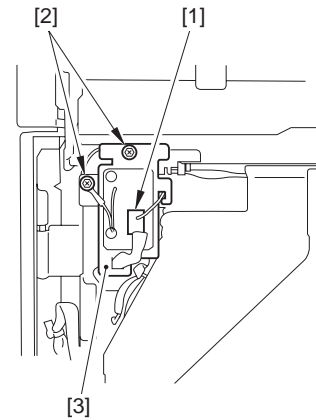

F-10-92

## 10.5.20 Motor Driver PCB

### 10.5.20.1 Before Removing Motor Driver PCB

iR5065 / iR 5055 / iR5075 / iR5075N / iR5065N / iR5055N

- 1) Remove the charger unit (this step is necessary only for iR5075 for Japan). (page 10-22)Reference[Removing the Charger unit]
- 2) Remove the rear cover (upper). (page 10-13)Reference[Removing the Rear Cover (Upper)]
- 3) Remove the rear cover (lower). (page 10-13)Reference[Removing the Rear Cover (Lower)]
- 4) Remove the main controller box cover. (page 10-17)Reference[Removing the Main Controller Box Cover]
- 5) Remove the right cover (upper rear). (page 10-12)Reference[Removing the Right Cover (Upper Rear)]
- 6) Remove the main controller box. (page 4-13)Reference[Removing the Main Controller Box]
- 7) Remove the right cover (lower rear). (page 10-12)Reference[Removing the Right Cover (Lower Rear)]
- 8) Remove the collecting toner bottle holder. (page 5-29)Reference[Removing the Collecting Toner Bottle Holder]

### 10.5.20.2 Removing Motor Driver PCB

iR5065 / iR 5055 / iR5075 / iR5075N / iR5065N / iR5055N

- 1) Remove the motor driver PCB [2].  
- 6 screws [1]  
- 10 connectors

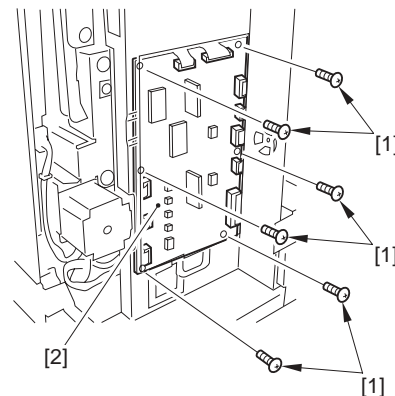

F-10-93

## 10.5.21 Primary Fan Duct

### 10.5.21.1 Before Removing Primary fan Duct

iR5065 / iR 5055 / iR5075 / iR5075N / iR5065N / iR5055N

- 1) Detach the front cover. (page 10-13) Reference[Removing the Front Cover]
- 2) Detach the toner supply cover. (page 10-14) Reference[Removing the Toner Supply Cover]

### 10.5.21.2 Removing Primary fan Duct

iR5065 / iR 5055 / iR5075 / iR5075N / iR5065N / iR5055N

- 1) Detach the connector cover [2].  
- 1 screw [1]

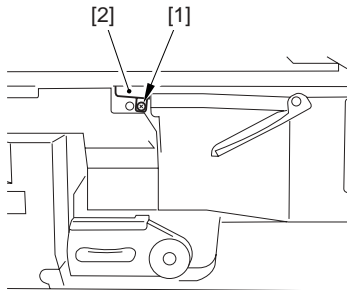

F-10-94

- 2) Remove the primary fan duct [3].  
- 2 screws [1]  
- 1 connector [2]

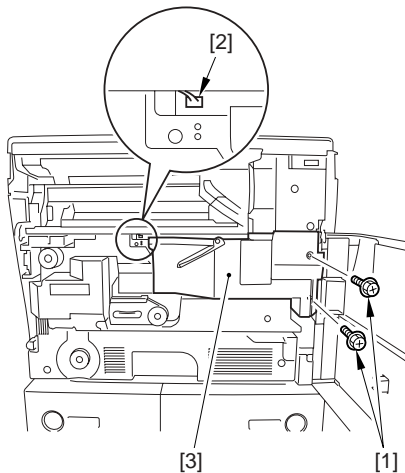

F-10-95

### 10.5.22 Primary Charging Assembly Fan

#### 10.5.22.1 Before Removing Primary Charging Fan

iR5065 / iR 5055 / iR5075 / iR5075N / iR5065N / iR5055N

- 1) Detach the toner supply cover. (page 10-14) Reference[Removing the Toner Supply Cover]
- 2) Remove the primary fan duct. (page 10-29) Reference[Removing Primary fan Duct]

#### 10.5.22.2 Removing the Primary Charging Cooling Fan

iR5065 / iR 5055 / iR5075 / iR5075N / iR5065N / iR5055N

- 1) Detach the fan cover [2].  
- Screw [1] 6pc.

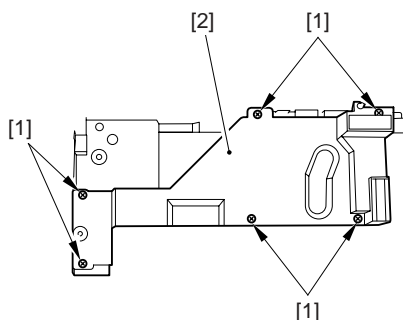

F-10-96

- 2) Disconnect the connector [1] from behind, and detach the primary charg-

ing cooling fan [2].

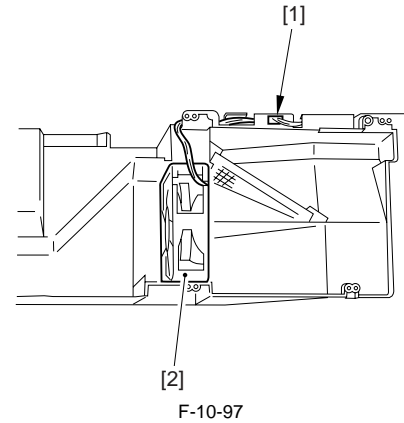

F-10-97

### 10.5.23 De-Curling Fan

#### 10.5.23.1 Before Removing the Curl-Removing Fan

iR5065 / iR 5055 / iR5075 / iR5075N / iR5065N / iR5055N

- 1) Remove the fixing front cover. (page 10-16) Reference[Removing the Fixing Front Cover]
- 2) Detach the fixing drive assembly. (page 10-22) Reference[Removing the Fixing Drive Assembly]

#### 10.5.23.2 Removing the Curl-Removing Fan

iR5065 / iR 5055 / iR5075 / iR5075N / iR5065N / iR5055N

- 1) Remove the curl-removing fan assembly [4].  
- Screw [1] 1pc.  
- Wire saddle [2] 2pc.  
- Edge saddle [3] 3pc.

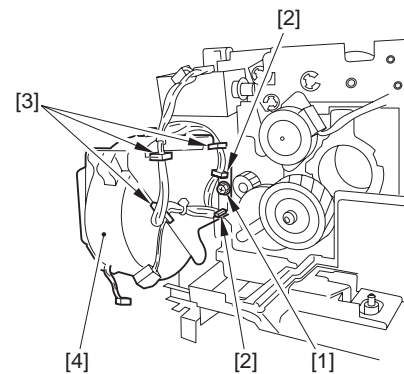

F-10-98

- 2) Separate the fan duct [2] and the curl-removing fan [3].  
- Screw [1] 2pc.

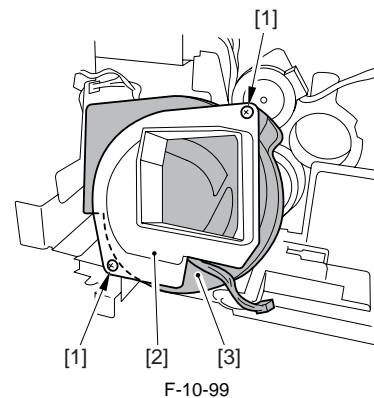

F-10-99

### 10.5.24 Feeding Fan

#### 10.5.24.1 Before Removing the Feeding Fan

iR5065 / iR 5055 / iR5075 / iR5075N / iR5065N / iR5055N

- 1) Detach the rear cover (upper). (page 10-13) Reference[Removing the

Rear Cover (Upper)]

**10.5.24.2 Removing the Feeding Fan**

iR5065 / iR 5055 / iR5075 / iR5075N / iR5065N / iR5055N

- 1) Disconnect all the connectors of the DC controller PCB.
- 2) Detach the DC controller base [2]; then, turn it over.
  - Wire saddle 14pc. (to free the harness)
  - Edge saddle 1pc. (to free the harness)
  - Reuse band 1pc.
  - Screw [1] 8pc. (to remove the grounding wire)

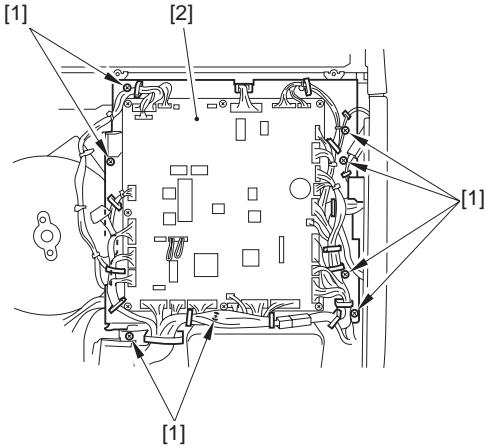

F-10-100

- 3) Detach the DC controller base [6].
  - Connector [1] 3pc.
  - Wire saddle [2] 2pc. (to free the harness [3])
  - Edge saddle [4] 1pc. (to free the harness [5])

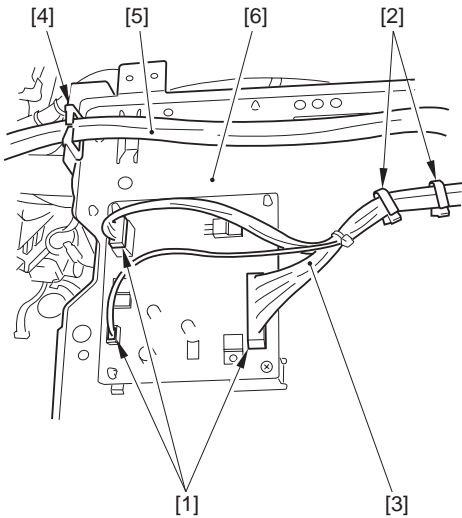

F-10-101

- 4) Detach the feed fan cover [2].
  - Screw [1] 3pc.
- 5) Detach the feed fan [4].
  - Screw [3] 3pc.

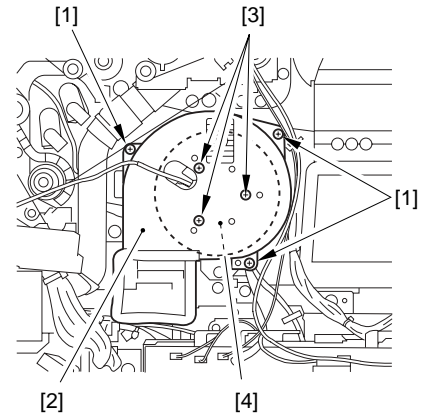

F-10-102

**10.5.25 HVT Fan**

**10.5.25.1 Before Removing the HVT Fan**

iR5065 / iR 5055 / iR5075 / iR5075N / iR5065N / iR5055N

- 1) Remove the charger unit (this step is necessary only for iR5075 for Japan). (page 10-22)Reference[Removing the Charger unit]
- 2) Remove the rear cover (upper). (page 10-13)Reference[Removing the Rear Cover (Upper)]
- 3) Detach the rear cover (lower). (page 10-13)Reference[Removing the Rear Cover (Lower)]

**10.5.25.2 Removing the HVT Fan**

iR5065 / iR 5055 / iR5075 / iR5075N / iR5065N / iR5055N

- 1) Detach the HVT fan [1].
  - Cable guide [2]
  - Connector [3]
  - Screw [4] 3pc.

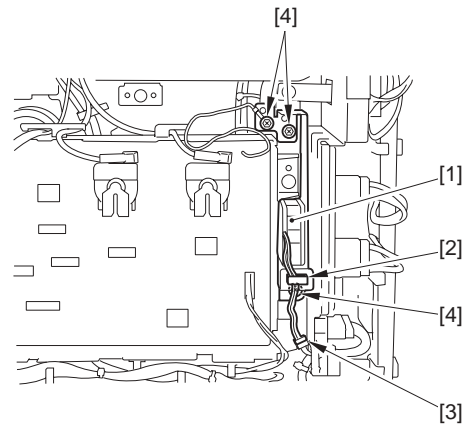

F-10-103

**10.5.26 Duplex Feed Fan**

**10.5.26.1 Before Removing the Duplex Feeding Fan**

iR5065 / iR 5055 / iR5075 / iR5075N / iR5065N / iR5055N

- 1) Detach the duplex feeding front cover. (page 10-14)Reference[Removing the Duplexing Feed Front Cover]
- 2) Remove the duplex feeding unit. (page 8-49)Reference[Removing the Duplex Feeding Unit]

**10.5.26.2 Removing the Duplex Feeding Fan**

iR5065 / iR 5055 / iR5075 / iR5075N / iR5065N / iR5055N

- 1) Detach the fan base [3].
  - Screw [1] 2pc.
  - Connector [2] 1pc.

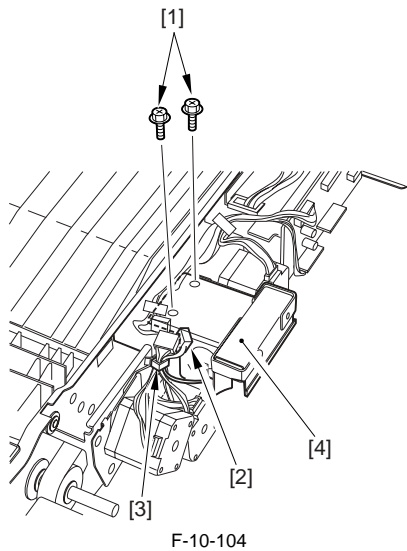

- 2) Detach the duplex feeding fan [2].  
- Screw [1] 2pc.



Be sure that the arrow indicating the direction of air is as indicated when mounting the duplex feeding fan.

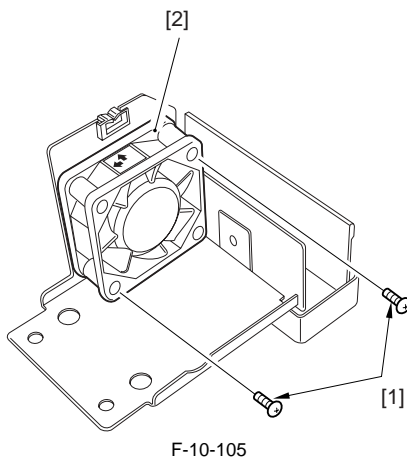

### 10.5.27 Exhaust Fan

#### 10.5.27.1 Before Removing the Exhaust Fan

iR5065 / iR 5055 / iR5075 / iR5075N / iR5065N / iR5055N

- 1) Remove the charger unit (this step is necessary only for iR5075 for Japan). (page 10-22)Reference[Removing the Charger unit]
- 2) Remove the rear cover (upper). (page 10-13)Reference[Removing the Rear Cover (Upper)]
- 3) Detach the rear cover (lower). (page 10-13)Reference[Removing the Rear Cover (Lower)]

#### 10.5.27.2 Removing the Exhaust Fan

iR5065 / iR 5055 / iR5075 / iR5075N / iR5065N / iR5055N

- 1) Detach the exhaust fan duct [3].  
- Screw [1] 3pc.  
- Connector [2] 1pc.

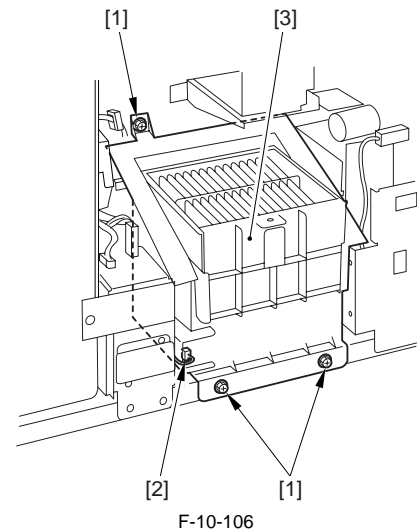

- 2) Detach the exhaust fan [4].  
- Screw [1] 2pc.  
- Connector [2] 1pc.  
- Fan grid [3]

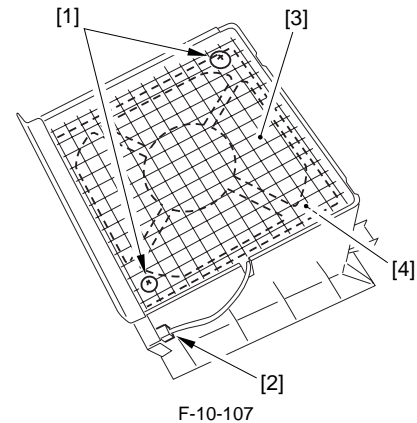

### 10.5.28 DC Power Supply Fan

#### 10.5.28.1 Before Removing the DC Power Supply Fan

iR5065 / iR 5055 / iR5075 / iR5075N / iR5065N / iR5055N

- 1) Detach the left cover (upper). (page 10-12)Reference[Removing the Left Cover (Upper)]
- 2) Detach the left cover (middle). (page 10-14)Reference[Removing the Left Cover (Middle)]
- 3) Detach the left cover (lower). (page 10-13)Reference[Removing the Left Cover (Lower)]
- 4) Detach the printer power supply PCB. (page 10-24)Reference[Removing Printer Power Supply PCB]

#### 10.5.28.2 Removing the DC Power Supply Fan

iR5065 / iR 5055 / iR5075 / iR5075N / iR5065N / iR5055N

- 1) Disconnect the connector [1].

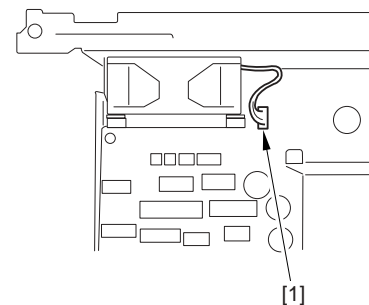

- 2) Detach the DC power supply fan [2].  
- Screw [1] 3pc.

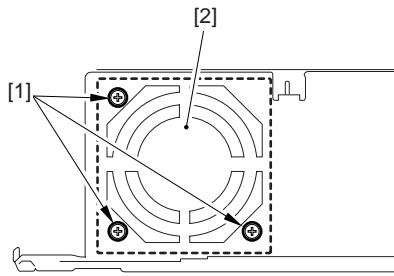

F-10-109

**10.5.29 Fixing Heater Power Supply Cooling Fan**

**10.5.29.1 Before Removing the Fixing Heater Power Supply Cooling Fan**

iR5065 / iR 5055 / iR5075 / iR5075N / iR5065N / iR5055N

- 1) Detach the left cover (upper). (page 10-12)Reference[Removing the Left Cover (Upper)]
- 2) Detach the left cover (middle). (page 10-14)Reference[Removing the Left Cover (Middle)]

**10.5.29.2 Removing the Fixing Heater Power Supply Cooling Fan**

iR5065 / iR 5055 / iR5075 / iR5075N / iR5065N / iR5055N

- 1) Detach the PCB cover [2].  
- Screw [1] 5pc.

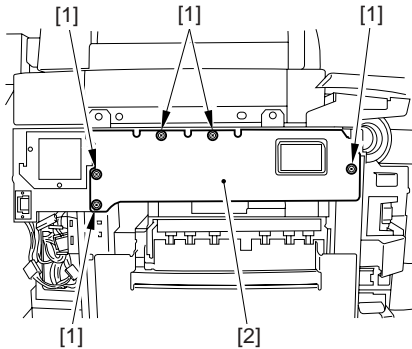

F-10-110

- 2) Open the 2 wire saddles [1].
- 3) Disconnect the 7 connectors [2].
- 4) Detach the fixing heater power supply unit [4].  
- Screw [3] 3pc.

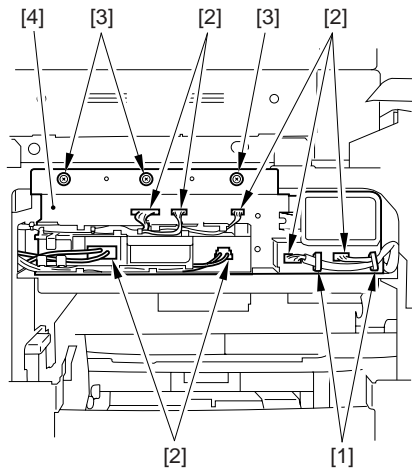

F-10-111

- 5) Detach the fixing heater power supply unit cover [2].  
- Screw [1] 14pc.

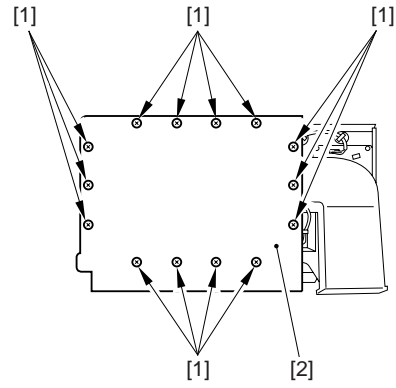

F-10-112

- 6) Detach the duct [2].  
- Screw [1] 2pc.
- 7) Detach the fixing heater power supply fan [5].  
- Connector [3] 1pc.  
- Wire saddle [4] 2pc.

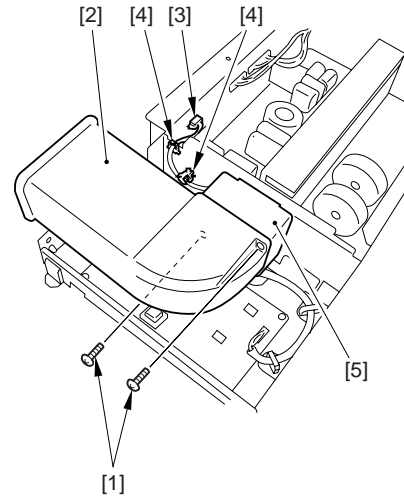

F-10-113

**10.5.30 Circulation Duct Fan**

**10.5.30.1 Before Removing the Circulation Duct Fan**

iR5065 / iR 5055 / iR5075 / iR5075N / iR5065N / iR5055N

- 1) Detach the left cover (upper). (page 10-12)Reference[Removing the Left Cover (Upper)]
- 2) Detach the left cover (middle). (page 10-14)Reference[Removing the Left Cover (Middle)]

**10.5.30.2 Removing the Circulation Duct Fan**

iR5065 / iR 5055 / iR5075 / iR5075N / iR5065N / iR5055N

- 1) Free the harness [1] from the harness guide [2].
- 2) Disconnect the connector [3].
- 3) Detach the fixing heater power supply cooling fan [5] together with its duct.  
- Screw [4] 3pc.

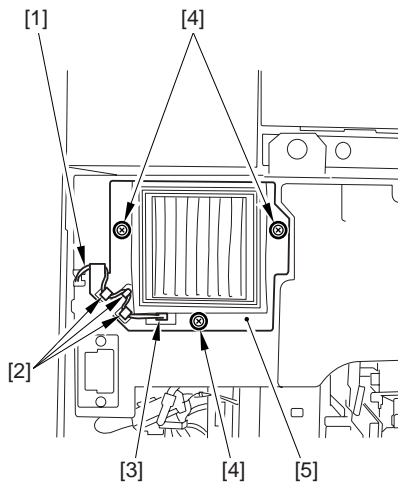

F-10-114

- 4) Disconnect the connector [1].
- 5) Detach the circulation duct fan [3].  
- Screw [2] 2pc.

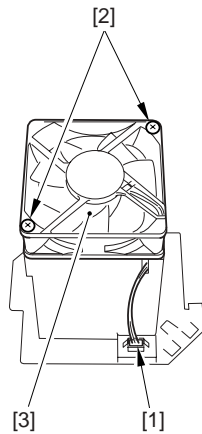

F-10-115

### 10.5.31 Motor of Main Drive Assembly

#### 10.5.31.1 Before Removing the Main Motor

iR5065 / iR 5055 / iR5075 / iR5075N / iR5065N / iR5055N

- 1) Detach the rear cover (upper). ([page 10-13](#))Reference[Removing the Rear Cover (Upper)]
- 2) Detach the main controller box cover. ([page 10-17](#))Reference[Removing the Main Controller Box Cover]
- 3) Removing the Right Cover (Upper Rear). ([page 10-12](#))Reference[Removing the Right Cover (Upper Rear)]
- 4) Remove the main controller box. ([page 4-13](#))Reference[Removing the Main Controller Box]
- 5) Detach the right cover (lower rear). ([page 10-12](#))Reference[Removing the Right Cover (Lower Rear)]

#### 10.5.31.2 Removing the Main Motor

iR5065 / iR 5055 / iR5075 / iR5075N / iR5065N / iR5055N

- 1) Move the main power switch base [3] to the side.  
- Screw [1] 2pc.  
- Clamp [2] 2pc.

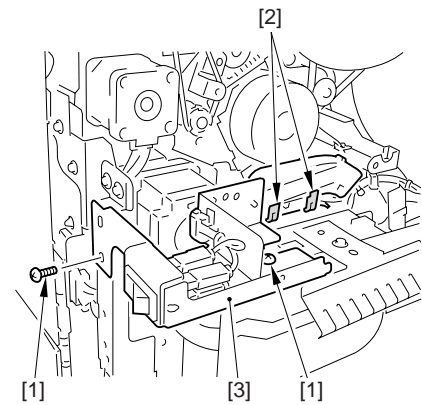

F-10-116

- 2) Detach the main motor [2].  
- Screw [1] 3pc.

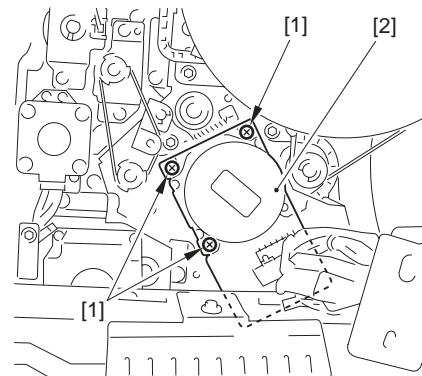

F-10-117

- 3) Disconnect the 2 connectors [1] from the main motor [2].

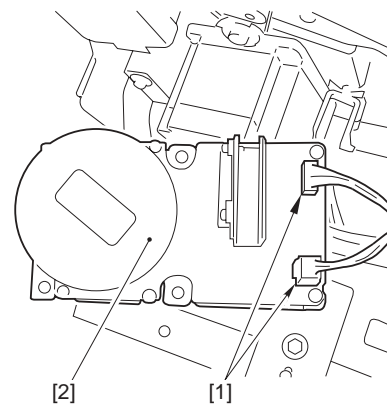

F-10-118

### 10.5.32 Fixing Driver Motor

#### 10.5.32.1 Before Removing the Fixing Motor

iR5065 / iR 5055 / iR5075 / iR5075N / iR5065N / iR5055N

- 1) Detach the fixing front cover. ([page 10-16](#))Reference[Removing the Fixing Front Cover]

#### 10.5.32.2 Removing the Fixing Motor

iR5065 / iR 5055 / iR5075 / iR5075N / iR5065N / iR5055N

- 1) Detach the fixing motor assembly [3].  
- Connector [1] 2pc.  
- Screw [2] 3pc.

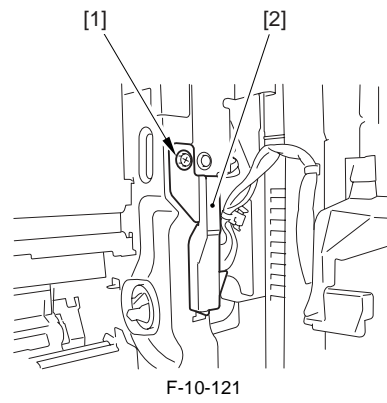
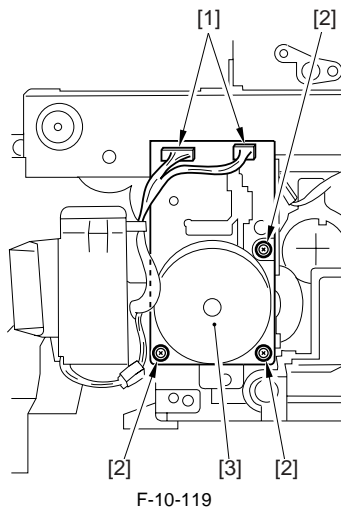

- 3) Lift and detach the right door unit (upper).  
 - Reuse band [1] 1pc.  
 - Connector [2] 1pc.

### 10.5.33 Right Door

#### 10.5.33.1 Before Removing the Right Door Unit (Upper)

iR5065 / iR 5055 / iR5075 / iR5075N / iR5065N / iR5055N

- 1) Detach the right cover (upper rear). (page 10-12)Reference[Removing the Right Cover (Upper Rear)]
- 2) Detach the right cover (upper). (page 10-12)Reference[Removing the Right Cover (Upper)]

#### 10.5.33.2 Removing the Right Door Unit (Upper)

iR5065 / iR 5055 / iR5075 / iR5075N / iR5065N / iR5055N

- 1) Open the right door unit (upper) [1]; then, remove the 1 screw [2] of the door strap and open fully the right door unit (upper).

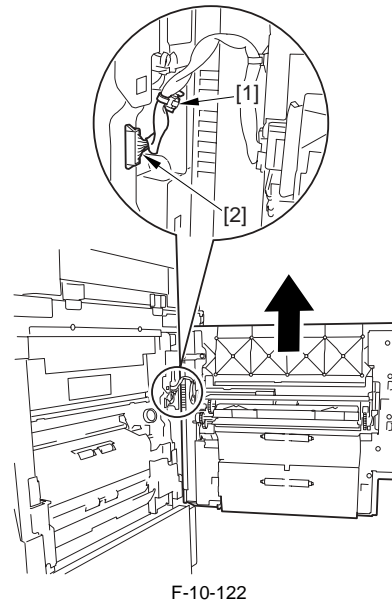
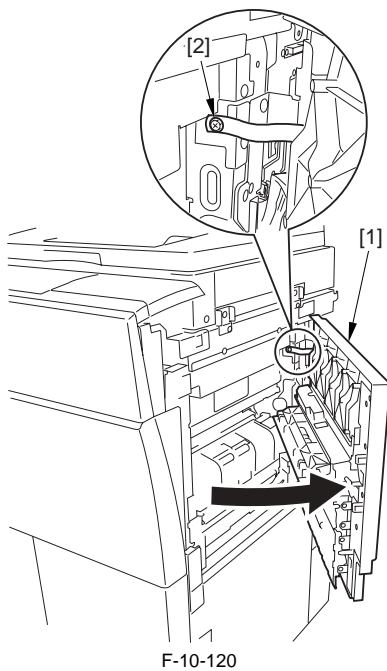

- 2) Detach the connector cover [2].  
 - Screw [1] 1pc.



---

## Chapter 11 MEAP

---



---

# Contents

11.1 MEAP.....	11-1
11.1.1 Checking the Operating Environment.....	11-1
11.1.2 Setting Up the Network.....	11-4
11.1.3 Setting the method to login to SMS.....	11-5
11.1.4 Login to SMS.....	11-9
11.1.5 Checking Application List.....	11-11
11.1.6 Starting and Stopping a MEAP Application.....	11-12
11.1.7 Checking the Platform Information.....	11-13
11.1.8 MEAP Specifications.....	11-14
11.1.9 Checking the System Information of a MEAP Application with SMS.....	11-15
11.1.10 Printing the System Information of a MEAP Application.....	11-16
11.1.11 Reference (Application System Information).....	11-17
11.1.12 Installing an Application.....	11-18
11.1.13 MEAP Enterprise Service Manager.....	11-20
11.1.14 Adding a License File.....	11-21
11.1.15 Disabling a License File (suspending a license).....	11-23
11.1.16 Downloading/Removing an Invalidated License File.....	11-25
11.1.17 Reusable license.....	11-27
11.1.18 License for forwarding.....	11-27
11.1.19 Uninstalling an Application.....	11-30
11.1.20 Changing Login Services.....	11-31
11.1.21 Initializing the Password.....	11-35
11.1.22 Creating a Backup for MEAP Application Area, Formatting the Hard Disk, Restoring the MEAP Application Area with the Backup, Using the SST (Service Support Tool).....	11-36
11.1.23 Replacing the Hard Disk Drive.....	11-38
11.1.24 MEAP Safe Mode.....	11-38
11.1.25 Setting HTTP port for MEAP application (level 2).....	11-39
11.1.26 Reference material.....	11-42
11.1.27 Option for exclusive individual measure.....	11-43



## 11.1 MEAP

### 11.1.1 Checking the Operating Environment.

iR5065 / iR 5055 / iR5075 / iR5075N / iR5065N / iR5055N

This section lists the requirements on the operating environment for the maintenance.

**Memo:**

Java Script must be enabled in every environment.

**Important:**

For the following operations in the combined environment of Windows XP and Internet Explorer6, Java2 Runtime Environment Standard Edition 1.3.1 or later is required.

- User registration / edit in SDL
- User registration / edit in SSO local device
- Use of SSO remote login in SSO

### Remote Login of Default Authentication or Simple Device Login (SDL), Remote UI, and Portal Services

Remote Login of Default Authentication or Simple Device Login (SDL), Remote UI, and Portal Services guarantee operation under the following system environment.

T-11-1

Operating System	Supported browser
Microsoft Windows 98 SE Microsoft Windows NT Workstation 4.0 SP6a	Microsoft Internet Explorer 5.01 SP2 Microsoft Internet Explorer 5.5 SP2 Microsoft Internet Explorer 6 SP1
Microsoft Windows ME	Microsoft Internet Explorer 5.5 SP2 Microsoft Internet Explorer 6 SP1
Microsoft Windows 2000 Professional SP3	Microsoft Internet Explorer 5.01 SP2 Microsoft Internet Explorer 5.5 SP2 Microsoft Internet Explorer 6 SP1
Microsoft Windows XP Professional / Home	Microsoft Internet Explorer 6 Gold Microsoft Internet Explorer 6 SP1
Mac OS 8.6 - 9.x	Microsoft Internet Explorer 5.0 - 5.1.6
Mac OS X 10 - 10.2.4	Microsoft Internet Explorer 5.2.2

### Remote UI (RUI)

RUI guarantees operation under the following system environment.

T-11-2

Operating System	Supported browser
Microsoft Windows 98 SE Microsoft Windows ME Microsoft Windows NT Workstation 4.0 Microsoft Windows 2000 Professional Microsoft Windows XP	Microsoft Internet Explorer 5.01 SP2 or later Netscape Communicator 4.6 or later
MacOS 8.6 or later	Microsoft Internet Explorer 5.0 or later

### SMS

SMS guarantees operation under the following system environment.

T-11-3

Operating System	Supported browser
Microsoft Windows 98 SE	Microsoft Internet Explorer 5.5 SP2 Microsoft Internet Explorer 6 SP1
Microsoft Windows 2000 Professional	Microsoft Internet Explorer 5.5 SP2 Microsoft Internet Explorer 6 SP1
Microsoft Windows XP	Microsoft Internet Explorer 6 Microsoft Internet Explorer 6 SP1

**SDL and SSO with Local Device Authentication (user registration/edit functions)**

For user registration / edit in SDL and SSO(with Local Authentication), following system requirements must be satisfied.  
System environment for administrator

T-11-4

Operating System	Supported browser
Microsoft Windows 98 SE	Microsoft Internet Explorer 5.5 SP2 Microsoft Internet Explorer 6 SP1
Microsoft Windows 2000 Professional SP3	Microsoft Internet Explorer 5.5 SP2 Microsoft Internet Explorer 6 SP1
Microsoft Windows XP	Microsoft Internet Explorer 6 Microsoft Internet Explorer 6 SP1

System environment for end user

T-11-5

Operating System	Supported browser
Microsoft Windows 98 SE Microsoft Windows NT Workstation4.0	Microsoft Internet Explorer 5.0.1 SP2 Microsoft Internet Explorer 5.5 SP2 Microsoft Internet Explorer 6 SP1
Microsoft Windows ME	Microsoft Internet Explorer 5.5 SP2 Microsoft Internet Explorer 6 SP1
Microsoft Windows 2000 Professional	Microsoft Internet Explorer 5.0.1 SP2 Microsoft Internet Explorer 5.5 SP2 Microsoft Internet Explorer 6 SP1
Microsoft Windows XP Professional	Microsoft Internet Explorer 6 SP1

**SSO domain authentication environment****Windows server for Security Agent to be installed**

Security Agent (hereinafter SA) guarantees operation in the following system environment.

T-11-6

Hardware	Memory	256MB or more
	Hard disk	Empty capacity of 15MB or more
	CPU	Processor more than Intel Celeron 800 MHz corresponding

Software	OS	Microsoft Windows 2000 Professional SP4
		Microsoft Windows 2000 Server SP4
		Microsoft Windows XP Professional SP2
		Microsoft Windows Server 2003 SP1
		Microsoft Windows Server 2003 R2
Corresponding Active Directory		Microsoft Windows 2000 Server SP4
		Microsoft Windows Server 2003 SP1 *
		Microsoft Windows Server 2003 R2 *

\* Construction of SSO domain environment by using Active Directory of Microsoft Windows Server 2003 needs SA of version 2.0.1 or newer, SSO Login application of version 3.0.0 or newer.

Combination list of the versions of SSO Login application of MEAP device and SA

T-11-7

Product Name of MEAP Device			Version of SSO Login Application	Version of SA						
US	EU	AO		V1.1.0	V1.2.0	V1.3.0	V1.3.1	V2.0.0	V2.0.1	V3.0.1
iR5020/ iR5020i/ iR6020/ iR6020i	iR5020N/ iR5020i/ iR6020N/ iR6020i	iR5020i/ iR6020i	V1.1.0	A	A	A	A	A	A	A
iR2220i/ iR2220N/ iR3320i/ iR3320N	iR2220i/ iR2220N/ iR3320i/ iR3320N	iR2220i/ iR3320i	V1.1.0	A	A	A	A	A	A	A
iR C3220/ iR C2620	iR C3220/ iR C2620	iR C3220/ iR C2620	V1.1.1	A	A	A	A	A	A	A
iR 2270/ iR 2870/ iR 3035/ iR 3045	iR 2270/ iR 2870/ iR 3035/ iR 3045	iR 2270/ 2870/3035/3045	V1.1.2	A	A	A	A	A	A	A
			V2.2.7	A	A	A	A	B	B	B
iR85+/ iR8070/ iR105+/ iR9070	iR85+/ iR8070/ iR105+/ iR9070	iR85+/ iR8070/ iR105+/ iR9070	V1.1.3	A	A	A	A	A	A	A
			V2.2.7	A	A	A	A	B	B	B
iR 5570/ iR 6570	iR 5570 / 6570	iR 5570 / 6570	V2.0.0, V2.2.9	A	A	A	A	B	B	B
iR C3170U/ iR C3170i	iR 3170C/ iR 3170Ci/ iR C2570/ iR C2570i	iR C3170/ iR C3170i/ iR C2570/ iR C2570i	V2.2.6	A	A	A	A	B	B	B
iR C5870U/ iR C6870U	iR 5870C/ iR 5870Ci/ iR 6870C/ iR 6870Ci	iR C5870/ iR C5870i/ iR C6870/ iR C6870i	V2.4.0	A	A	A	A	B	B	B
iR7086/ iR7095/ iR7095 Printer/ iR7105	iR7086/ iR7095/ iR7095 P/ iR7105	iR7086/ iR7095/ iR7095 P/ iR7105	V2.5.0	A	A	A	A	B	B	B
iR C5180i/ iR C4580i/ iR C4080i	iR C4080/ iR C4080N/ iR C4580/ iR C4580N/ iR C5180/ iR C5180N	iR C4080/ iR C4080N/ iR C4580/ iR C4580N/ iR C5180/ iR C5180N	V3.0.0	A	A	A	A	B	C	C
imagePRESS C1	imagePRESS C1	imagePRESS C1	V3.1.0	A	A	A	A	B	C	C
iR C2880/ iR C3380	iR C2880 / C3380	iR C2880 / C3380	V3.2.0	A	A	A	A	B	C	C
iR3025/ iR3030/ iR3035/ iR3045	iR3025/ iR3030/ iR3035/ iR3045	iR3025/ iR3030/ iR3035/ iR3045	V3.4.1	A	A	A	A	B	C	C
iR 5050	-	-	V3.9.0	A	A	A	A	B	C	C
iR 5055/ iR 5065/ iR 5075	iR 5055/ iR 5065/ iR 5075	iR 5055/ iR 5065/ iR 5075	V3.5.0	A	A	A	A	B	C	C
iR C5185	iR C5185	iR C5185	V3.6.0	A	A	A	A	B	C	C
imagePRESS C7000VP	imagePRESS C7000VP	imagePRESS C7000VP	V3.8.0	A	A	A	A	B	C	C

A = SSO basic function support

B = SSO basic function + Multi domain function + LLS cache function support

C = SSO basic function + Multi domain function + LLS cache function support + Server 2003 Active Directory support

**Memo:**

-It must improve in the version of SSO Login application and version of SA when you want to use the function B or C.

-The right of access to the domain controller and the right of access to the Windows 2003 DNS are necessary, when the domain authentication is used with SSO.

**Important:**

-The device using SSO authentication and the Windows server on which Security Agent is installed must exist in the same domain.

-In the case that Security Agent has been installed in Windows XP Professional SP2, Windows Server 2003 SP1/Server 2003 R2 and Windows Firewall is set enabled, Security Agent (SA.exe) needs to be added as an exceptional program of Windows Firewall. If not being designated a directory of installation, SA.exe is stored in the following directory. C:\Program Files\Canon\SSOPackage\SecurityAgent

-In the case that Active Directory has been constructed in Windows Server 2003 SP1/Server 2003 R2 and Windows Firewall is set enabled, TCP port '5678' used by Security Agent needs to be added in Windows Firewall.

**Browser**

The following combinations of operations are guaranteed for the access from Web browser to MEAP device.

T-11-8

OS	Supported Browser
Microsoft Windows 98SE Microsoft Windows NT Workstation 4.0 SP6a	Microsoft Internet Explorer 5.01 SP2, Microsoft Internet Explorer 5.5 SP2, Microsoft Internet Explorer 6 SP1
Microsoft Windows ME	Microsoft Internet Explorer 5.5 SP2, Microsoft Internet Explorer 6 SP1
Microsoft Windows 2000 Professional SP3	Microsoft Internet Explorer 5.01 SP3, Microsoft Internet Explorer 5.5 SP2, Microsoft Internet Explorer 6 SP1,
Microsoft Windows XP Professional	Microsoft Internet Explorer 6 SP1,

**11.1.2 Setting Up the Network**

iR5065 / iR 5055 / iR5075 / iR5075N / iR5065N / iR5055N

To allow a MEAP device to accept accesses through the network, for example you operate a device with SMS, the On option must be selected on Use HTTP screen. The option is selected by default. The setting can be changed on the control panel of the MEAP device.

1) Make the following selections: **Ad Func** button > **System Settings** button> **Down-arrow** button.

**Memo:**

If the System manager ID and system password have already been assigned, ID Entry dialog appears after System Settings button is pressed. Enter the system manager ID and the password, and click ID key to go into System Management Mode.

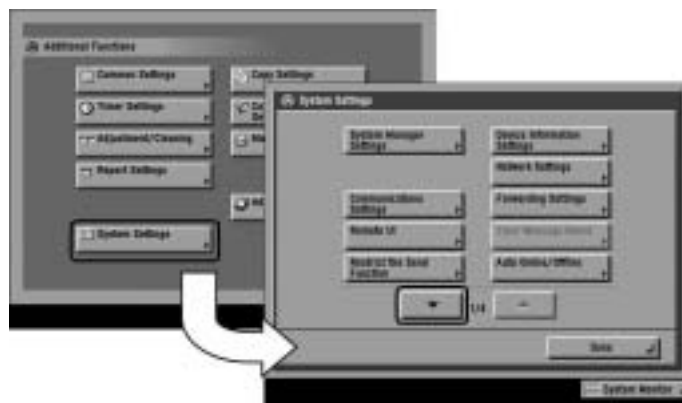

F-11-1

2) Make the following selections: **MEAP Settings** button > **Use HTTP** button> **On** button > **OK** button .



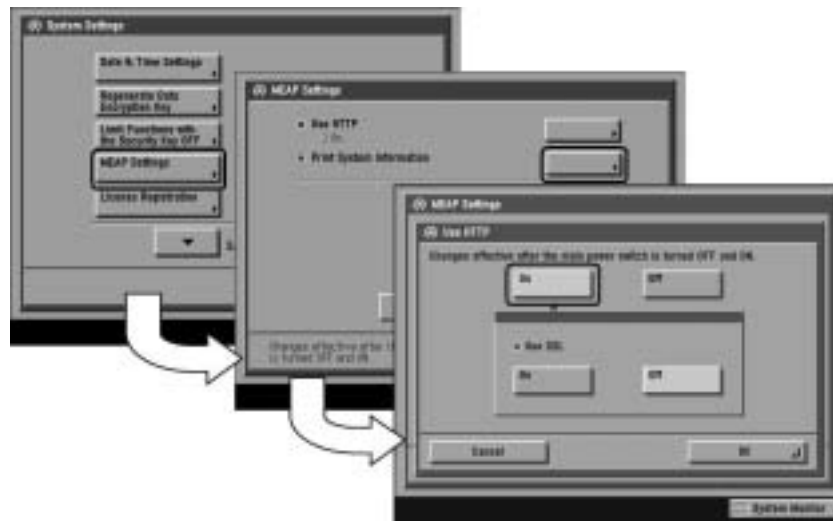

F-11-2

**Memo:**

When using SSL, set [Use SSL] ON.

(This setting is also applied to the SSL setting of RUI. Same is true in the case of setting SSL ON on the side of RUI.)

Setting [Use SSL] ON displays the message dialogue 'Changes effective after the main power switch is turned OFF and ON'. Press [OK].



F-11-3

- 3) Press Done button as many times as necessary until the Basic screen appears.
- 4) Turn off the device's main power; wait for 10 sec, and then turn the power back on.



- The setting [Use HTTP] is not actually enabled/disabled until you have turned off and then on the device's main power switch.
- You cannot make a connection through a proxy server. If a proxy server is in use, enter the IP address of the MEAP device in the Exceptions field for the browser. Open Internet Options dialog of Internet Explorer and select Connections tab, LAN Settings button, Use a proxy server option, and Advanced button of Proxy server group. Proxy Settings dialog will open. The Exceptions field is in the dialog. As network settings vary among environments, consult the network administrator.
- If Cookie and JavaScript are not enabled in the Web browser, you will not be able to use SMS.
- To type text using the Web browser, use the characters compatible with the MEAP device's touch panel display. The MEAP device may not properly recognize some characters.
- When [se SSL] is made available, it is necessary to set the key and the certificate necessary for the SSL communication. Set the key and the certificate by SSL with [Certificate Settings] that exists in [System Settings] > [Network Settings] > [TCP/IP Settings] on the iR device.

### 11.1.3 Setting the method to login to SMS

iR5065 / iR 5055 / iR5075 / iR5075N / iR5065N / iR5055N

SMS Installer Service, which is used to login SMS includes Password Authentication and Remote Login Service Authentication (henceforce: RLS Authentication). Password Authentication is an authentication method only by password. RLS Authentication is an authentication method using SDL / SSO by ID and password. Either or both of the authentication methods can be enabled by changing the setting.

**Memo:**

If Default Authentication is selected as the device authentication method, 'RLS Authentication' is not selectable as SMS Login method. Also, if 'RLS Authentication' is selected, the device authentication method (Default Authentication, SDL, SSO) cannot be changed.

Setting of login method to SMS (Start/Stop) must be made after logging-in by the other login method. In other words, setting for Start/Stop of Password Authentication is made after logging-in with RLS Authentication, and setting for Start/Stop of RLS Authentication is made after logging-in with Password Authentication.

The table below shows the setting methods for each combination of login method and Start/Stop.

T-11-9

	Start RLS Authentication	Stop RLS Authentication
Start Password Authentication	Login available with either method	Login available only with Password Authentication
Stop Password Authentication	Login available only with RLS Authentication	Setting unavailable



When only RLS Authentication is enabled, there may be a case you cannot login to device for the following reasons.

- Authentication server down
- Disconnection with authentication server due to network failure

In these cases, boot the device as MEAP SAFE mode from device service mode.

By booting the device as MEAP SAFE mode, login to SMS becomes available as Default Authentication is enabled. After login to SMS, set RLS Authentication as Started, return the device to normal mode, and then login by RLS Authentication.

**Setting for login by Password Authentication**

1) In order to make a setting for login by Password Authentication, you need to login by RLS Authentication. Therefore, login by RLS Authentication.

Login screen (In case authentication method is SSO)



F-11-4

2) Select 'System Management' tab > 'Utility' tab > 'Application Management Function' tab.



F-11-5

3) In order to enable login by Password Authentication, tick SMS Installer Service (Password Authentication) radio button and then click [Start]. On the other hand, in order to disable login by Password Authentication, clear the tick of SMS Installer Service (Password Authentication) radio button and click [Stop].



F-11-6

4) Logout once and login again to check to see that the setting is applied properly. In case the setting is changed from 'Stop' to 'Start', login screen that was not seen before is displayed. In case the setting is changed from 'Start' to 'Stop', access to login screen leads to the screen below and login becomes unavailable.

Login error screen



F-11-7

#### Setting for login by RLS Authentication

1) In order to make a setting for Login by RLS Authentication, you need to Login by Password Authentication.

Login screen by Password Authentication



F-11-8

2) Select 'System Management' tab > 'Utility' tab > 'Application Management Function' tab.



F-11-9

3) In order to enable Login by RLS Authentication, tick SMS Installer Service (Remote Login Service Authentication) radio button and then click [Start]. On the other hand, in order to disable login by RLS Authentication, clear the tick of SMS Installer Service (Remote Login Service Authentication) radio button and click [Stop].



F-11-10

4) Logout once and login again to check to see that the setting is applied properly. In case the setting is changed from 'Stop' to 'Start', login screen that was not seen before is displayed. In case the setting is changed from 'Start' to 'Stop', access to login screen leads to the screen below and Login becomes unavailable.

Login error screen



F-11-11

### 11.1.4 Login to SMS

iR5065 / iR 5055 / iR5075 / iR5075N / iR5065N / iR5055N

#### Login by Password Authentication

- 1) Access SMS from the browser of the PC connected to the network on which the MEAP device operates.  
**URL: <http://<MEAP Device IP address>:8000/sms/>**  
**Ex.) <http://172.16.188.240:8000/sms/>**

#### Memo:

- The default password is "MeapSmsLogin." (The password is case-sensitive.)
- When you want to change the display original language, change in the box in the right of the screen. This setting is not affect by the setting of the language of the device.



F-11-12

- 2) The following screen appears if the password has been changed by the user's system administrator. If so, check with the system administrator for the new password. Keep in mind that there is no special password offered for service work.



F-11-13

**Login by RLS Authentication**

1) Access SMS by RLS Authentication from the PC browser on the same network as the MEAP device.

**URL:** <http://<IP address of MEAP device>:8000/sms/rls/>

**Ex.)** <http://172.16.188.240:8000/sms/rls/>

**Memo:**

- In case the device authentication method is SSO and login to domain, enter User Name, Password, and Login Destination registered in Active Directory, and click 'Log in'.
- In case the device authentication method is SDL or SSO and login to 'this device', enter User Name and Password registered in the device and click 'Log in'.

In the case the device authentication method is SSO



F-11-14

In the case the device authentication method is SDL



F-11-15

### 11.1.5 Checking Application List

iR5065 / iR 5055 / iR5075 / iR5075N / iR5065N / iR5055N

The page of **Application List** is designed to show resources arranged according to applications. The page gives you a good idea of how much of the device's memory is being used by the applications (both in absolute and relative terms) as well as how much memory still remains. Check this page before adding an application.

The information is collected from the manifest (headers) - in other words, the size of a resource represents the size as it is declared by the application in question, not necessarily the size of resources actually used by the application. The items of information include the following:

- hard disk
- memory
- thread
- socket
- file descriptor

You will not be able to install an application if the size of the remaining memory falls short of the size declared by the application. Moreover, the specifications have been designed so that an application will not be able to start up if there is a shortage of memory for any of the foregoing items (i.e., memory, thread, socket, file descriptor). To find out if there is enough memory, go through the following steps:

- 1) Log in to SMS.
- 2) Click Application List tab.
- 3) Check the displayed information:
  - a. Information on Applications
    - Name (of the application)
    - Installation (date)
    - Application ID
    - Status
    - License
    - Resources Used
  - b. Resource Information
    - Amount Used
    - Remaining
    - Percent Used

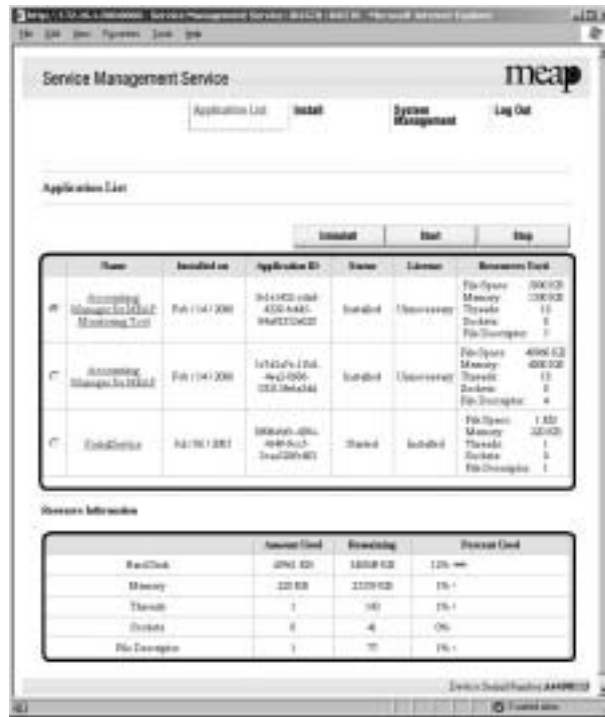

F-11-16

### 11.1.6 Starting and Stopping a MEAP Application

iR5065 / iR 5055 / iR5075 / iR5075N / iR5065N / iR5055N

- 1) Log in to the SMS.
- 2) Click 'Application List'.
- 3) Click the radio button of the MEAP application in question, and click 'Start' or 'Stop'.



F-11-17

- 4) Check to see that the status of the MEAP application in question is either "Started" or "Stopped."





F-11-18

### 11.1.7 Checking the Platform Information

iR5065 / iR 5055 / iR5075 / iR5075N / iR5065N / iR5055N

You can check the versions of MEAP Contents, MEAP Specifications, and Java Virtual Machine of the device.



Some applications may not be installed to some MEAP devices of specific specifications. (See 'MEAP Specifications').

- 1) Log in to SMS.
- 2) Click **System Management** tab.



F-11-19

- 3) Click **System Info** tab.



F-11-20

**11.1.8 MEAP Specifications**

iR5065 / iR 5055 / iR5075 / iR5075N / iR5065N / iR5055N

**What is MEAP Specifications (MEAP Spec Version)?**

MEAP Specifications is one of the information required to judge whether MEAP applications can be operated or not. With MEAP Specifications, you can prevent an application that uses a specific function of device from being installed onto the device that does not have the function.

**About Name**

MEAP Specification is shown as 'MEAP Specifications' in the screen to check the version on the side of device that supports MEAP (counter confirmation button) and MEAP platform (SMS). On the other hand, in the manifest file of MEAP application, it is shown as 'MeapSpecVersion' (described in the same way in the SDK document)

(Note) 'MEAP Specifications' hereafter in this document.

**Mechanism**

MEAP platform judges whether MEAP applications can be operated on it using on the 2 information below:

- Device Specification ID
- MEAP Specifications

Device Specification ID shows information such as the original functions of MFP (including print, scan, and copy), and one that differs by model such as maximum copy number, thus each model has a different ID. (It is easy to determine the IDs for this reason.) MEAP application declares 1 or more Device Specification ID required for its execution. Declaration of multiple Device Specification IDs means that the application is operable in all the models declared. Upon installation of MEAP application in (using) SMS or MEAP Enterprise Service Manager, matching of Device Specification ID is executed on the side of MEAP platform machine. The machine which doesn't support the ID declared by the application rejects installation of such an application.

Meanwhile, MEAP Specifications shows other information than defined by Device Specification ID above, including network and security. Thus each model does not always have the same version.

MEAP application declares 1 or more MEAP Specifications required for its execution. Declaration of multiple Device Specification IDs means that the application is operable in all the environments declared. Upon installation of MEAP application in SMS or MEAP Enterprise Service Manager, matching of MEAP Specifications is executed on the side of MEAP platform machine. The machine which doesn't support the version declared by the application rejects installation of such an application.

MEAP Spec Version for each model

T-11-10

Product Name	USA	EUR	OCE	SPL	KOR	Initial MEAPSpecVer	Change information
iR 6020	Y	Y	Y	Y	-		
iR 5020	Y	Y	Y	Y	-		
iR 3320	Y	Y	Y	Y	-		
iR 2220	Y	Y	Y	Y	-		
iR C3220	Y	Y	Y	Y	-	1, 2, 3	
iR C2620	Y	Y	Y	Y	-	1, 2, 3	
iR 4570	Y	Y	Y	Y	Y	5	5, 6, 7 (System v30.xx later)
iR 2870	Y	Y	Y	Y	Y	5	5, 6, 7 (System v30.xx later)
iR 2270	Y	Y	Y	Y	-	5	5, 6, 7 (System v30.xx later)
iR 3570	Y	Y	Y	Y	Y	5	5, 6, 7 (System v30.xx later)
iR85+	Y	Y	Y	-	-		
iR 8070	Y	Y	Y	Y	-	5	5, 6, 7 (System v10.xx later)

Product Name	USA	EUR	OCE	SPL	KOR	Initial MEAPSpecVer	Change information
iR 105+	Y	Y	Y	Y	-	5	5, 6, 7 (System v10.xx later)
iR 9070	Y	Y	Y	Y	-	5	5, 6, 7 (System v10.xx later)
iR 6570	Y	Y	Y	Y	Y	5, 6	5, 6, 7, 9 (System v20.xx later)
iR 5570	Y	Y	Y	Y	Y	5, 6	5, 6, 7, 9 (System v20.xx later)
iR C3170	Y	Y	Y	Y	Y	5, 6, 7	
iR C2570	-	Y	Y	Y	Y	5, 6, 7	
iR 7105	Y	Y	Y	Y	Y	5, 6, 7	
iR 7095	Y	Y	Y	Y	Y	5, 6, 7	
iR 7086	Y	Y	Y	Y	-	5, 6, 7	
iR 7095P	Y	Y	Y	Y	-	5, 6, 7	
iR C6870	Y	Y	Y	Y	Y	5, 6, 7	
iR C5870	Y	Y	Y	Y	-	5, 6, 7	
iR C5180	Y	-	Y	Y	Y	5, 6, 7, 9, 10, 11	5, 6, 7, 9, 10, 11, 13, 14, 15 (System v50.xx later)
CLC5151	-	Y	-	-	-		5, 6, 7, 9, 10, 11, 13, 14, 15 (System v50.xx later)
iR C4580	Y	-	Y	Y	Y	5, 6, 7, 9, 10, 11	5, 6, 7, 9, 10, 11, 13, 14, 15 (System v50.xx later)
CLC4040	-	Y	-	-	-		5, 6, 7, 9, 10, 11, 13, 14, 15 (System v50.xx later)
iR C4080	Y	Y	Y	-	-		5, 6, 7, 9, 10, 11, 13, 14, 15 (System v50.xx later)
iR C5185						5, 6, 7, 9, 10, 11, 13, 14, 15	
imagePRESS C1	Y	Y	Y	Y	Y	5, 6, 7, 9, 10, 11	
iR C3380	Y	Y	Y	Y	Y	5, 6, 7, 9, 10, 11, 13	
iR C2880	Y	Y	Y	Y	Y	5, 6, 7, 9, 10, 11, 13	
iR 3025	Y	Y	Y	Y	-	5, 6, 7, 9, 10, 11, 13	
iR 3045	Y	Y	Y	Y	Y	5, 6, 7, 9, 10, 11, 13	
iR 3035	Y	Y	Y	Y	Y	5, 6, 7, 9, 10, 11, 13	
iR 3030	Y	Y	Y	Y	Y	5, 6, 7, 9, 10, 11, 13	
iR 5050	Y	-	-	-	-	5,6,7,9,10,11,13,14,15,17,18	
iR 5055	Y	Y	Y	Y	Y	5, 6, 7, 9, 10, 11, 13	
iR 5065	Y	Y	Y	Y	Y	5, 6, 7, 9, 10, 11, 13	
iR 5075	Y	Y	Y	Y	Y	5, 6, 7, 9, 10, 11, 13	
imagePRESS C7000VP	Y	Y	Y	Y	Y	5, 6, 7, 9, 10, 11, 13	

\* Due to the change in I/F specifications, these models support '5' only.

T-11-11

#### MEAP Spec Version

MEAP Spec Version	Description
1	MEAP basic function
2	MEAP Spec Version 1 function and SSL/TSL + Proxy
3	[Reserved]
5	MEAP Spec Version 1 function and CPCA V2 + ERS (Error Recovery Service) + New SSL/TSL
6	[Reserved]
7	MEAP Spec Version 5 function and Compact PDF + OCR PDF(Text Searchable) + USB-Host(Buffering of Interrupt Transfer)
9	[Reserved]
10	MEAP Spec Version 5 function and USB-Host(Exception + ClearFeature + SetFeature + HotPlug) + WINS address acquisition using MIBAgent + TimerService + SSL client authentication
11	MEAP Spec Version 5 function and AMS
13	MEAP Spec Version 5 function and J2ME1.1 Support + Encrypted PDF + Trace and smooth PDF + CTK2.0
14	Device signature PDF
15	IMI + ERS (API addition for IMI)
17	Acquiring images of JBIG format
18	Parsing XML documents (XML parser)

### 11.1.9 Checking the System Information of a MEAP Application with SMS

iR5065 / iR 5055 / iR5075 / iR5075N / iR5065N / iR5055N

- 1) Log in to SMS.
- 2) Click **System Management** tab.

- 3) On System Management screen, click **System Info** tab.
- 4) Click **Details** button.



F-11-21

- 5) When the following status information of MEAP applications (including the system application) appears in a different window, copy and paste all information to create an attachment (text information) for preparing a problem report. You can also use this function whenever you want to check the status of any particular application.

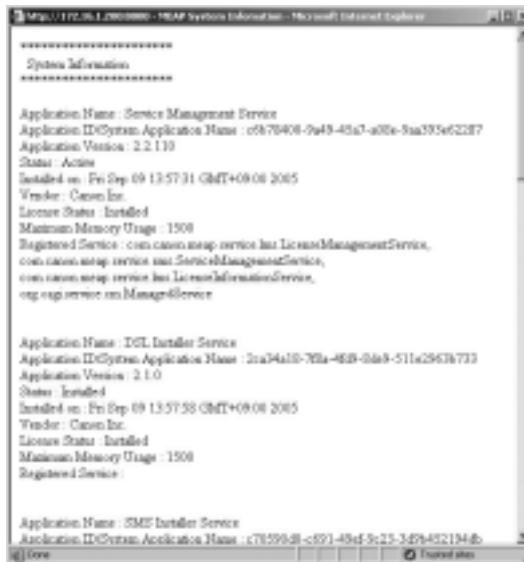

F-11-22

### 11.1.10 Printing the System Information of a MEAP Application

iR5065 / iR 5055 / iR5075 / iR5075N / iR5065N / iR5055N

- 1) Make the following selections: **Additional Functions** button > **System Settings** button> the **down-arrow** button.

**Memo:**

If the System manager ID and system password have already been assigned, ID Entry dialog appears after System Settings button is pressed. Enter the system manager ID and the password, and click ID key.

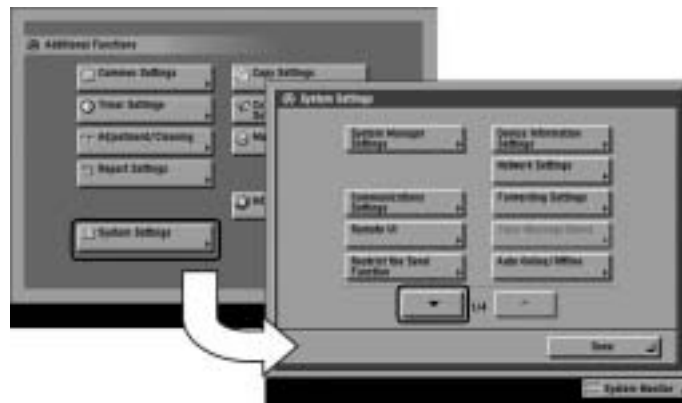

F-11-23

2) Make the following selections: **MEAP Settings** button > **Print System Information** button > **Yes** button.

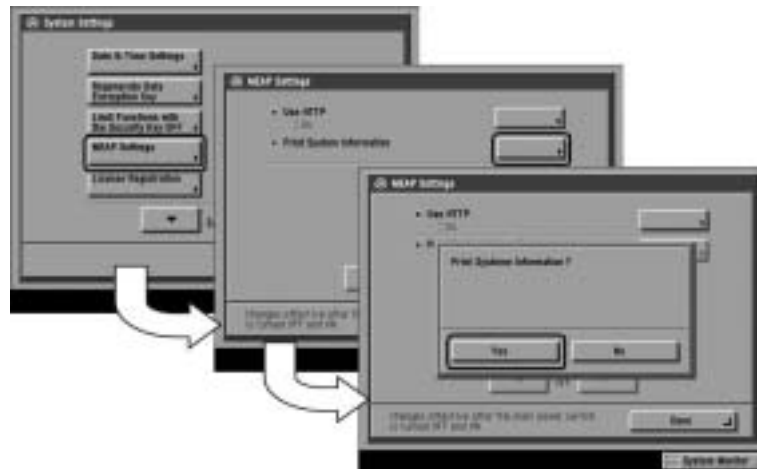

F-11-24

3) Press **Done** button as many times as necessary until the Basic screen appears.

4) Turn off the MEAP device's main power; wait for 10 sec, and then turn the power back on.

---

**Important:**

The previous version of printing function for MEAP application status information (system information) was depended on PDL. However, current version of function is not dependent on PDL. So even device for which PDL is not available can print it. (Since iRC3220)

---

### 11.1.11 Reference (Application System Information)

iR5065 / iR 5055 / iR5075 / iR5075N / iR5065N / iR5055N

You can check all applications installed to the device at a glance with the MEAP application status information and, thus, it is important for you to provide it when you are reporting a problem.

The following items of information will be indicated or printed for individual applications:

---

**Memo:**

The system information shown on the screen and the system information printed in the MEAP device's user mode are exactly the same.

---

T-11-12

Application System Information

```

Application Name: C-Cabinet Gateway for MEAP
Application ID/System Application Name: 03a46668-63e4-4636-9cbb-492b6cef05d5
Application Version: 1.0.0
Status: Resolved
Installed on: Tue Oct 21 14:00:11 GMT+09:00 2003
Vendor : Canon Inc.
License Status : Installed
Maximum Memory Usage : 1024
Registered Service :
  
```

**Application Name**

It is the name (bundle-name) declared in a statement within the application program. It may not necessarily be identical to the name of the program.

**Application ID/System Application Name**

In the case of a system application, it will be the file name. If a general application, it is the application ID (application-ID) declared in a statement within the application program. Within the device, the applications are set apart by means of their application IDs.

**Application Version**

It is the version of the application (bundle-version) declared in a statement within the application program.

**Status**

It indicates the status of the application in question; specifically,

Installed: the application has been installed.

Active: the application is being in use.

Resolved: the application is at rest.

**Installed On**

It indicates the date on which the application was installed.

**Vendor**

It is the name of the vendor that developed the application, and is the name (bundle-vendor) declared in a statement within the application program.

**License Status**

It indicates the status of the license; specifically,

None: no license is needed.

Not Installed: no license has been installed.

Installed: the appropriate license has been installed.

Invalid: the license has been invalidated.

Overlimit: the license has been used beyond its permitted limit.

**License Expires After**

It indicates the date after which the license expires. If the status of the license is 'none', this item will not be printed.

**License Upper Limit**

It indicates the limit imposed on individual counter readings. If the status of the license is 'none', this item will not be printed.

**Counter Value**

It is the current counter reading of a specific counter. If the status of the license is 'none', this item will not be printed.

**Maximum Memory Usage**

It indicates the maximum amount of memory that the application uses. It is the amount (maximum memory usage) declared in a statement within the application program, and is expressed in kilobytes.

**Registered Service**

It is a list of services that have been registered by the application with the MEAP framework. Some services may not have printable data.

**11.1.12 Installing an Application**

iR5065 / iR 5055 / iR5075 / iR5075N / iR5065N / iR5055N

**Important:**

- To install an application, the user needs to use the following URL when accessing the license control system to obtain a license file. In doing so, he/she needs to register the license access number of the application and the serial number of the device.

<http://www.canon.com/meap/>

-Maximum 20 applications can be installed (In iR5160/iR6060/iR2250/iR2850/iR3350, one is the portal service already installed at the time of shipment from the factory)

-The following are the resource amounts assured for each device in the operation of one MEAP application. These values are for reference purpose only, therefore the unused resource of SMS needs to be checked at the time of installation of MEAP application.

The displayed values of SMS resource may be larger than the followings since the actual values vary according to the log-in service (authentication function) selected by users and the configuration (future models).

T-11-13

Product Name	HDD	Memory	Thread	Socket	File Description	
iR5020/iR6020/iR2220/iR3320	300MB	20MB	128	48	42	
iRC2620/iRC3220	400MB	20MB	128	48	42	
iR2270/iR2870/iR3570/iR4570/iR85/iR8070/iR6570/iR5570	400MB	20MB	128	48	42	
iRC3170/iRC2570	400MB	20MB	128	48	42	
iR7086/iR7095/iR7105	400MB	20MB	128	48	42	
iRC4080/iRC4580/iRC5180	Initial MEAP Spec Ver	1024MB	20MB	128	48	42
	Change Information	1024MB	30MB	128	128	128
imagePRESS C1	1024MB	20MB	128	48	42	
iRC2880/iRC3380	1024MB	20MB	128	48	42	
iR3025/iR3030/iR3035/iR3045	400MB	20/30MB*	128	48	42	
iR5050	1024MB	30MB	128	128	128	
iR5055/iR5065/iR5075	1024MB	20MB	128	48	42	
iRC5185	1024MB	30MB	128	128	42	
imagePRESS C7000VP	1024MB	20MB	128	48	42	

\*20MB for 512MB model, 30MB for 768MB model.

- As for memory, check the available resource when starting up the application. For other resources other than memory, check them when installing.
- Some applications call for a specific set of conditions for installation. For details, see the User's Guide that comes with the individual applications.

- 1) Long on to SMS.
- 2) Click **Install** tab.



F-11-25

- 3) Check that **Install Application/License** page appears.
- 4) Click **Browse** button, and select the application file and the license file of the application; then, click **OK** button.

**Memo:**

Application File: identified by the extension "jar".

License File: identified by the extension "lic".



F-11-26

- 5) See the message "Installing...Please wait a moment."



F-11-27

**Important:**

- You cannot install only the license.
- You will not be able to install the application without using the appropriate license. Be sure to select its license file.
- If you are adding a license to an existing application, see 1.3.10 Adding a License File.
- If you are updating an existing application, stop the application; then, install the new application or its license file. You will not be able to update an application while it is running.

6) Check the contents of the **Confirm** page; then, click **OK** button.



F-11-28

7) Some applications show a screen to indicate the terms of agreement. Read the terms, and click **OK**.

8) Check the message "Installing...Please wait a moment." appears, beginning the installation.

9) Check **Application List** page appears when the installation is completed.

**Important:**

To use the application that you have just installed, you must make sure that the application status is Started.

### 11.1.13 MEAP Enterprise Service Manager

iR5065 / iR 5055 / iR5075 / iR5075N / iR5065N / iR5055N

**Outline**

MEAP Enterprise Service Manager is the PC application utility to perform batch installation, unistallation and management of MEAP application and license files required for installation of applications, on several MEAP-available devices on network.

The main targets are system administrators in big companies and CANON service engineers (end users of devices do not use).

It is used when customized applications delivered to a certain company needs to be managed collectively.

Previous SMS can manage only one device at a time. This utility reduces the management cost of devices and TCO.



**Major functions**

Discovery of devices available for MEAP  
 Discovery of devices available for MEAP on network  
 Storage of the serial number list of discovered device  
 Installation of application and license file  
 Management of application (starting / stopping)  
 Uninstallation of application  
 Others

**System configuration**

MEAP Enterprise Service Manager (MEAP ESM) functions in combination with DIS (DSL Installer Service) installed on the MEAP platform side of the device. This system can be used only for MEAP-available device with appropriate DIS installed.

(\* ) When using this system on the firmware for version upgrading on October 2003 or older, version upgrading of the system software on the field device is necessary.

The versions available for ESM are as follows:

iR5160 / iR6020: System v54.02 or newer, MEAP Contents v53.07 or newer

iR2220 / iR3320: System v33.01 or newer, MEAP Contents v33.02 or newer

Other products: Available from the initial version



When installing MEAP Enterprise Service Manager (MEAP ESM) of master CD on PC, Microsoft '.NET Framework' v1.0 or v1.1 is necessary. The user should download it from the Web site of Microsoft.

**11.1.14 Adding a License File**

iR5065 / iR 5055 / iR5075 / iR5075N / iR5065N / iR5055N

1) Log on to SMS.

2) On **Application List**, click the name of the application to which you want to add a license file.



F-11-29

3) Check appears.

4) On Application/License Information page, click **License Management** button.



F-11-30

5) Click **Browse** button, and select the license file you want to install.



F-11-31

6) Click **Install** button.



F-11-32

7) Check the content of the confirmation page, and click **OK** button.

### 11.1.15 Disabling a License File (suspending a license)

iR5065 / iR 5055 / iR5075 / iR5075N / iR5065N / iR5055N

#### Important:

- To invalidate (or suspend) a license, you must first stop the application in question.
- Once suspended, the status of the license will be 'Not Installed', and its application will no longer be available for use.
- You can later restore a suspended license file as long as you are doing so on the same iR, the device with the same device serial number.
- When replacing the device due to lease up or trouble, use the license for forwarding (See 'License for forwarding').

1) Stop the application you want to uninstall on **Application List** page.



F-11-33

2) Click the name of the application that you want to disable.



F-11-34

3) License File Management page appears. On Application/License Information page, click **License Management** button.



F-11-35

4) Click **Disable** button.

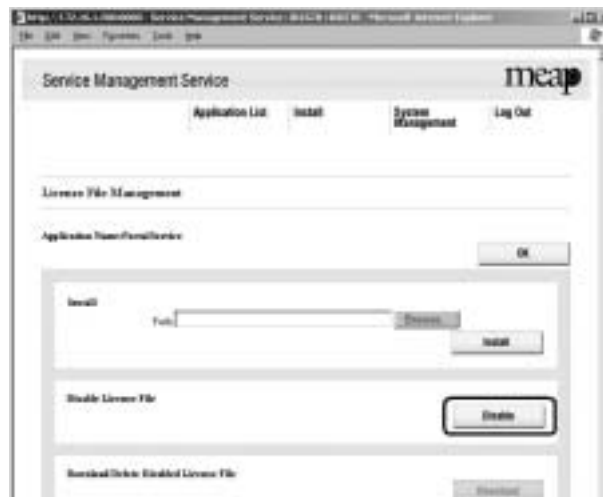

F-11-36

5) Click **OK**.

### 11.1.16 Downloading/Removing an Invalidated License File

iR5065 / iR 5055 / iR5075 / iR5075N / iR5065N / iR5055N

You must remove the invalidated license file before uninstalling an application. If re-installation is a possibility, you may download the license file to a PC for storage. To download or delete a license file, first disable it.

#### **Important:**

- Once you have removed an invalidated license file, you will no longer be able to download it from the MEAP device.

- 1) Login to SMS.
- 2) **Application List** page appears.
- 3) On **Application List** page, click the name of the application you want.

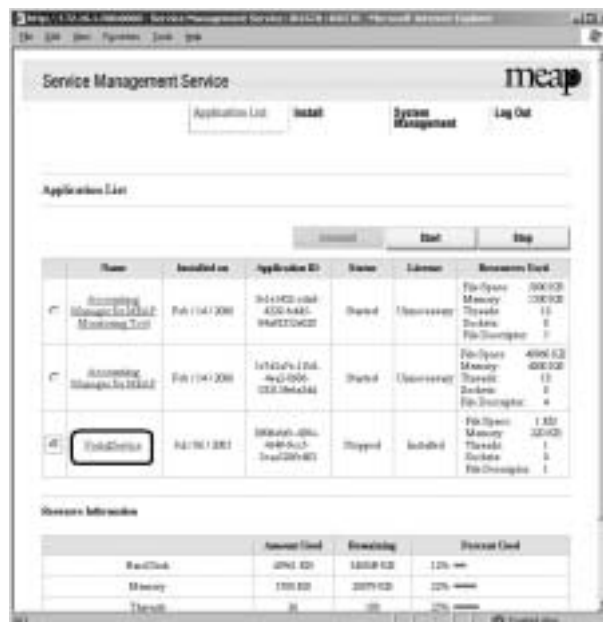

F-11-37

- 4) Check Application/License Information page appears.
- 5) On Application/License Information page, click **License Management** button.



F-11-38

6) License File Management page appears. To download, click **Download** button.



F-11-39

7) When you have selected **Download** button, specify where you want to store the file by following the instructions on the screen.

8) To delete, click **Delete** button.



F-11-40

9) Check the confirmation page appears.

10) Click **OK** button.

---

**Important:**

- Without the license file, an application cannot be reinstalled even to the MEAP device that the application had been installed last time. Download and save the license file before deleting the application.

---

### 11.1.17 Reusable license

iR5065 / iR 5055 / iR5075 / iR5075N / iR5065N / iR5055N

Reinstallation was not able to perform for all license files. When reinstalling, Disable License file should be downloaded (see 'Disabling a License File' and 'Downloading / Removing an Invalidated License File' in this manual) or a license for reinstallation should be obtained from LMS, before reinstallation. This specification aims to prevent misuse of applications.

To increase convenience of users, only application with unlimited validity date and application counter (e.g. Portal Service, SDL, SSO) has been made to be able to install as many times as needed by the same license file. This kind of license is called 'Reusable license'.

---

**Memo:**

For devices for System version of 33.01, 54.02 (iR 2220 series / iR5020 series) or older, version upgrading is required. It is already installed in the model with iR C3220 or newer.

---

### 11.1.18 License for forwarding

iR5065 / iR 5055 / iR5075 / iR5075N / iR5065N / iR5055N

When the device is replaced due to lease up or trouble, it is possible to continue using the current license information of MEAP application by forwarding it to a new device. The license is forwarded by CE because the hidden page of SMS is used.

1) Log in to SMS, stop the application to be forwarded (see 'Starting and Stopping a MEAP Application' in this manual).



F-11-41

2) Move to the download page of license forwarded for the device as sender ([http:// IP address of device: 8000/sms/ForwardLicense](http://IP address of device: 8000/sms/ForwardLicense)).



F-11-42

3) Specify the application to be forwarded.



F-11-43

4) Click 'Disable' at Create Transfer License File.





F-11-44

5) The screen to check invalidation of the license is displayed. Click 'OK',



F-11-45

6) Icon of license file for forwarding is displayed in the box of license file downloading. Click 'Download'.

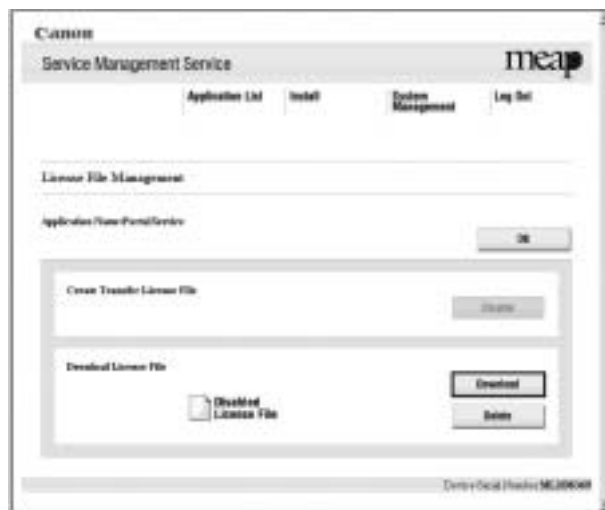

F-11-46

7) The dialogue 'File Download' is displayed. Click 'Save'.



F-11-47

8) Specify the download destination, click 'Save'.



F-11-48

9) After downloading the license file for forwarding, click 'Delete' to display the confirmation screen and click 'OK' to delete the file (in consideration of breakage of license for forwarding, deleting disabled license can be executed after all steps have been completed).

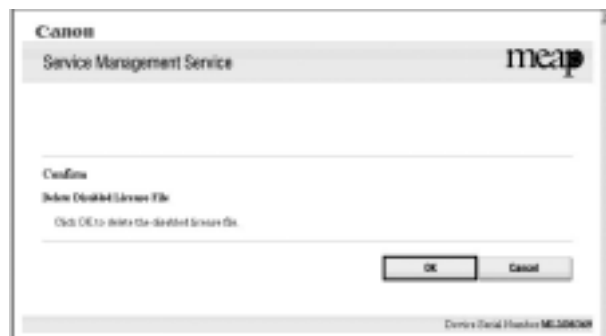

F-11-49

10) Log out of SMS.

11) Ask the sales company to issue a license for forwarding.

---

#### Memo:

When requesting issuance of license for forwarding, inform the sales company of the name of product name and serial No. of the device as sender, and of the name of product name and serial No. of the forwarding destination.

---

12) Install application using the license for forwarding issued by the sales company.

#### 11.1.19 Uninstalling an Application

iR5065 / iR 5055 / iR5075 / iR5075N / iR5065N / iR5055N

- 1) Log on to SMS, and click 'Application List' tab.
- 2) Check 'Application List' page appears.
- 3) On the application list, select the radio button of the application you want to uninstall, and click 'Uninstall' button.

**Memo:**

Dimmed Uninstall button shows that the selected application cannot be removed.



F-11-50

- 4) Check the screen to make sure that what is shown is the application you want to uninstall; then, click **OK** button. In response, the system runs an uninstall sessions.

**Important:**

- The status of the license must be 'Not Installed' or 'Unnecessary' for its application to be uninstalled. As necessary, go to License File Management page, and disable the license file before starting to remove it.
- A license file may be invalidated only when its application is not active.
- If the application you are uninstalling is associated with another application, a message will appear to indicate that the package exported by the application will no longer be available. Uninstalling such an application may also disable its associated applications.

### 11.1.20 Changing Login Services

iR5065 / iR 5055 / iR5075 / iR5075N / iR5065N / iR5055N

**Login Service Overview**

The login service is used to authenticate users who logs in to a MEAP device. You can change login services or uninstall them using System Management site.

At time of shipment, the login service offers the following 3 modes of authentication:

- Default authentication
- SDL (Simple Device Login)
- SSO (Single Sign-On)

**Important:**

- To set SDL, the registered information in SDL and the registered user data (Department ID and Password) in Department ID Management of the machine have to match.
- To set up SDL or SSO, Department ID Management must be set to Off in advance. To use SDL and Department ID Management simultaneously, set Department ID Management to On after switching the login service to SDL.
- If SSO is set as the login service, NetSpot Accountant is necessary for using Department ID Management.
- If SSO is set, you cannot use an optional card reader.
- To set to SSO, first adjust the current time for the PC where Active Directory is running, the iR, and the PC where users log on. If there is more than a 30-minute difference among them, an error occurs at logon.
- If SSO or SDL is set as login service, it takes time until the iR is ready to start up.
- When the SEND function is used in the environment of SDL and SSO, it is necessary to set each user's mail address to transmit E-mail. When the mail address is not set, E-mail cannot be transmitted. However, when i-Fax is transmitted, the mail address set to the device is used.

### Outline of Default Authentication

In this mode of authentication, you will be using Department ID Management or you will not be using any authentication mechanism. If you enable the Department ID Management in the MEAP device's Additional Functions mode, the user can use the device only when he/she enters an ID number (a 7-character ID and password) that has been registered from the device's touch panel display or through Remote UI.

**Outline of SDL (Simple Device Login)**

In this mode of authentication, you will be operating on a MEAP device on its own. You will store user information to the MEAP device's memory by accessing the device through a Web browser. SDL offers the following functions:

- a. it brings up the Login screen on the MEAP device's touch panel display for user authentication.
- b. it brings up the Login page when you access the MEAP device from Web browser to manage the numbers of printed and scanned sheets for each department ID working with the department ID management function. it operates in conjunction with the group ID control mechanisms to keep track of the number of print pages or scan pages according to group IDs.
- c. it enables register/editing of user authentication information through a Web browser.

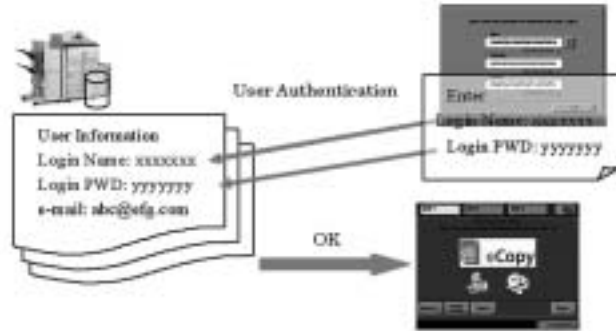

F-11-51

**Outline of SSO (Single Sign-On)**

This is the log-in service that can be operated on the domain of Active Directory environment network or at iR device. The following are the user authentication systems.

- Domain Authentication
- Local Device Authentication
- Domain Authentication + Local Device Authentication



- The three user authentication systems can be changed at Web browser (See 'Setting the User Authentication System' on MEAP Administrator Guide).
- The default setting is 'Domain Authentication + Local Device Authentication'. To increase security, set 'Domain Authentication' as user authentication system or change the user name and password of the administrator of Local Device Authentication from the default ones, just after starting to use SSO.

**Domain Authentication**

This is the authentication of the domains on network simultaneously with log-in to iR device, in combination with the domain controller on Active Directory environment network. It authenticates up to four domain users (multi domain) with trusts as well as the domain with iR device installed. Users select the domain name of log-in destination when they log in.

Optional NetSpot Accountant or imageWARE Accounting Manager enables analysis / management of the usage of iR device.

**Local Device Authentication**

This is the user authentication used for only iR device itself. The users to be authenticated is registered / managed by the database of iR device. The method of registration / management is the same as the one for SDL. The log-in destination is [this device].

**Domain Authentication + Local Device Authentication**

This is the user authentication system with the functions of both 'Domain Authentication' and 'Local Device Authentication'. Domain Authentication is useful to authenticate the users registered / managed by Active Directory, and Local Device Authentication is for authentication of the temporary users being not able to be added to Active Directory. In the case that any trouble of domain controller or Security Agent occurs, using Local Device Authentication enables emergency action until recovery.

In the following example, Domain A user with iR installed and Domain B having trusts with Domain A, and also the users registered in iR device itself can be authenticated. Users select the login destination (domain name or [This Device]) when they log in.

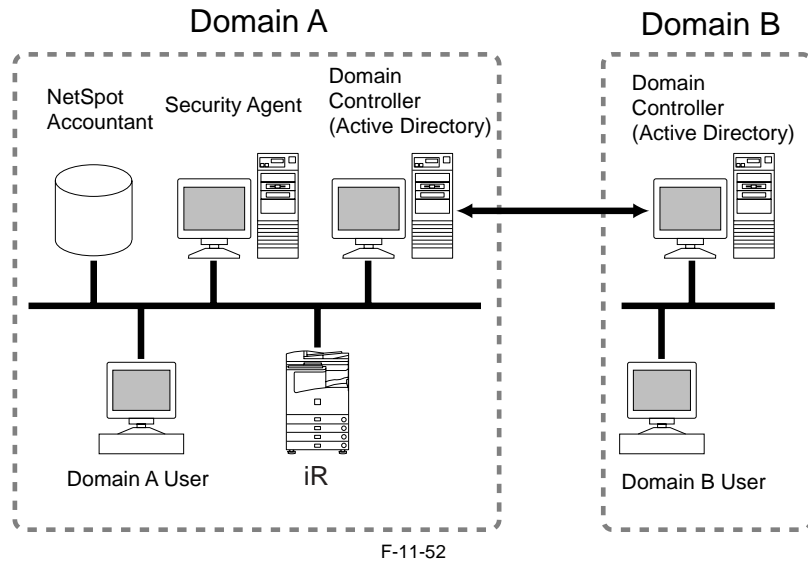

- Optional NetSpot Accountant or imageWARE Accounting Manager is necessary to use Domain Authentication and department ID management simultaneously. When Domain Authentication is set without combination with NetSpot Accountant or imageWARE Accounting Manager, log-in is impossible. Therefore, department ID management should not be 'ON'. If department ID management is set to 'ON' while using Domain Authentication and log-in becomes impossible, change the log-in service to Default Authentication and turn department ID management to [OFF].
- For combination with NSA / iWAM, it is necessary to set the user with administrative privilege of the domain on the SA service account.
- When the print count and scan count for each department ID needs to be managed in conjunction with Local Device Authentication and department ID management, turn department ID management to [ON]. To use simultaneously Local Device Authentication and department ID management, the information registered with Local Device Authentication should be matched with the user information of department ID management (department ID and password).
- The user information registered by SDL and the one by Local Device Authentication are managed separately in the iR device. The user information registered in one system is not reflected to the other.
- The card reader for optional control card cannot be used for Local Device Authentication. When using the card reader for control card, set SDL.
- Security Agent is necessary only for Domain Authentication.
- Security Agent should be installed on the computer in the domain with iR device installed.
- Installation of Security Agent is included in MEAP Administrator CD-ROM.

### Operating Environment

The operation is guaranteed for SDL or SSO if the system environment is in keeping with the following requirements:

#### SDL (registering/editing user information)

##### a. Operating System and Supported Browsers

T-11-14

Operating System	Supported browser
Windows 98 SE	Microsoft Internet Explorer 5.5 SP2 Microsoft Internet Explorer 6 SP1
Windows 2000 Professional SP3	Microsoft Internet Explorer 5.5 SP2 Microsoft Internet Explorer 6 SP1
Windows XP	Microsoft Internet Explorer 6 Microsoft Internet Explorer 6 SP1

#### Important:

- If you use Internet Explorer 6 on Windows XP, you will need Java 2 Runtime Environment Standard Edition 1.3.1.

### SSO

To use SSO, you must have a Windows server to which Active Directory has been installed as well as Security Agent.

#### 1) PC for hosting Security Agent

##### a. Supported OS

T-11-15

Operating System
Microsoft Windows 2000 Professional
Microsoft Windows 2000 Server
Microsoft Windows XP Professional
Microsoft Windows Server 2003



When using SA on WindowXP SP2, it is necessary to exclude Security Agent from the targets of firewall at the setting of the firewall.

- b. Others
  - Access right to Windows 2000 domain Name System (DNS)Access right to domain controller



For combination with NetSpot Accountant / iW Accounting Manager, and department ID management is turned on to use it, it is necessary to set the user with administrative privilege of the domain on the SA service account.

- 2) Client PC (if access from Web browser to MEAP device is desired)

- a. Operating System and Supported Browsers

T-11-16

Operating System	Supported Browsers
Windows 98 SE Windows NT Workstation 4.0 SP6a	Microsoft Internet Explorer 5.01 SP2 Microsoft Internet Explorer 5.5 SP2 Microsoft Internet Explorer 6 SP1
Windows ME	Microsoft Internet Explorer 5.5 SP2 Microsoft Internet Explorer 6 SP1
Windows 2000 Professional SP3	Microsoft Internet Explorer 5.01 SP3 Microsoft Internet Explorer 5.5 SP2 Microsoft Internet Explorer 6 SP1
Windows XP Professional	Microsoft Internet Explorer 6 SP1

- b. Others
  - Access right to Windows 2000 Domain Name System (DNS)
  - Access right to Domain Controller Client

**Steps to Change Login Services**

- 1) Make the following selections: **System Management > Enhanced Sys. App.**



F-11-53

- 2) A page will appear showing the various selections you can make for the login service. Select the radio button of the login service mode you want to use; then, click **Select** button.



F-11-54

3) When login service application you have selected turns to **Start after Restart**, turn off the device's main power, and turn it back on after 10 seconds.



F-11-55

### 11.1.21 Initializing the Password

iR5065 / iR 5055 / iR5075 / iR5075N / iR5065N / iR5055N

- 1) Get the switch license for initializing the password.  
Request the support of the regional headquarters of the Canon for switch license for initializing the password presenting the device serial number.
- 2) Click **Login** button leaving **Password** field blank or entering incorrect password. The Return to install Password Settings area appears. Click **Browse** button and select the switch license file prepared in advance.



F-11-56

3) When you click **Initialize** button, the confirmation message appears. Click **OK** button. Then Login page opens. Enter the default password 'MeapSmsLogin' to log in. The password is case-sensitive.

If you click **Cancel** button, the Login page opens without initializing the password.

### 11.1.22 Creating a Backup for MEAP Application Area, Formatting the Hard Disk, Restoring the MEAP Application Area with the Backup, Using the SST (Service Support Tool)

iR5065 / iR 5055 / iR5075 / iR5075N / iR5065N / iR5055N

You can back up the area of the HDD where MEAP applications reside to a PC, as when you want to format the HDD. MEAP devices use a license-based mechanism to control applications so that formatting the HDD will necessarily delete the jar files and application data, requiring you to not only reinstall them but also make necessary settings. (Doing so consists in obtaining special license files for reinstallation and downloading user data/settings, increasing your work load.)

If you use the SST's backup function, you will be able to temporarily put aside the area of MEAP applications, thus being free of the foregoing extra work. This function, however, is limited to a specific MEAP device (serial number), and cannot be used for illegal copying of applications.



You must not perform any other work (including checking operation) until the HDD has been backed up. This arrangement is to prevent a mismatch of MEAP counter readings and the HDD contents, and any fault in operation arising as the result of failure to observe this will not be covered by the guarantee of operation.

**Memo:**

The application that is installed with a reusable license can be reinstalled by using the same license.

**The following list shows the details of area that SST backs up;**

- Jar files of MEAP applications
- Settings set with MEAP applications.
- Note that SST does not back up images in Mailboxes that MEAP applications use.
- User information data registered with SDL

**Requirements for Backup Using the SST**

The following conditions must be met for use of the function:

1) Device Firmware Version

T-11-17

	Boot ROM	System	SST
iR2220 Series iR2250 Series	24.42 later	33.01 later	Since Ver 1.81
iR5020 Series iR5160 Series	24.42 later	54.02 later	Since Ver 1.81
Devices other than those listed the above.	Already supported since the 1st version.	Already supported since the 1st version.	The version supporting the corresponding devices.

2) SST Version

Version 1.81 or later. An earlier version will not permit the use of the function. If needed, upgrade the SST.

3) Space for backup

To back up the HDD of the iR, the PC must have approx 300 MB of free space at maximum.



## Making a Backup and Formatting Hard Disk Drive with Service Support Tool

- 1) If SDL or SSO is used for the login service, switch to default authentication before backing up the user information. Although SST will back up SDL user information, it is recommended to export the user information just in case. For SDL user information backup, go to User Management page of Simple Device Login site and export the data. (The SDL login page opens with the URL "<http://<device IP address>:8000/sdl/>").



If a hard disk of a system that uses SDL or SSO is formatted without changing the login service to the default authentication, the error message "The login service must be set again with SMS" appears and the system cannot start up when you attempt to restart the system after formatting. If this problem occurs, change the login service to SDL or SSO with SMS. If you cannot access to SMS since you do not have the IP address of the device, start the system with FIXIP mode - hold down the numeric keys 1 and 7 and turn the power switch on. The IP address "172.16.1.100" will be automatically assigned for the device. Then log in to SMS specifying the address.

- 2) While holding down the 2 and 8 buttons, start up the device in download mode.  
As in the case of Sraming.bin, the function is available only when the device is in Download Mode.
- 3) Connect the PC to the device and start the Service Support Tool.
- 4) In Download/Upload session of SST, select the appropriate device model, System in the tree view, and take necessary steps to connect to the device.
- 5) Click Upload the Backup Data button.
- 6) Click the option "Meapback.bin" from **Name** list of **Backup Data Available for Selection**, and click **Start Storing** button.

Selecting Meapback.bin



F-11-57

- 7) When the data has been generated, enter an appropriate name in **File name** field and click **Save** button; then, click **OK** button to end the backup session.
- 8) In **Selecting Model/Unit** screen, select **HDFFormat** and start formatting. All the partitions in the hard disk drive will be formatted.

### Restoring the Backup Data

- 1) After formatting the hard disk drive with SST, install the System, MEAP Contents, Language, and Remote UI files.
- 2) To restore the backup "Meapback.bin," click **Download the Backup Data** button.
- 3) Select the backup data file and click **Start Writing** button to download the backup data. Note that SST cannot restore backup data created with a different version.

Selecting Backup Data

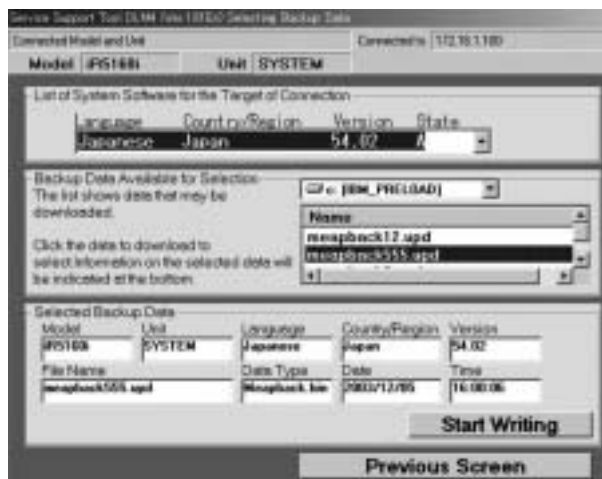

F-11-58

- 4) When the screen with OK button appears, the restoration of backup data finishes. Click **OK** button.
- 5) Reboot the main power and access the device with SMS and check that the MEAP applications are restored.
- 6) Restore non-MEAP backup data and settings that are saved before formatting the hard disk drive. The SDL user information is included in the backup data. You do not have to restore it.

### 11.1.23 Replacing the Hard Disk Drive

iR5065 / iR 5055 / iR5075 / iR5075N / iR5065N / iR5055N

If you must replace the hard disk drive because of a fault, all MEAP application files stored on it will also be lost, requiring you to re-install the applications and their license files in addition to performing the normal work associated with the replacement of the hard disk.

Like other counter information, MEAP counter information will remain after replacement. Reinstallation of MEAP applications calls for special license files designed to continue with the current counter readings, thus enabling the use of the applications until the date of their expiration. These special licenses are service tools, and are not offered to general users.

If you cannot make a backup of the license files as hard disk suffers a fault, contact the support staff of the regional headquarters of Canon telling the device serial number and the names of MEAP applications installed to the device to obtain the necessary special license files.

In the support departments of regional headquarters of Canon, all license files of the applications that have been issued are filed according to device serial numbers, enabling you to obtain a series of license files through a single screen as long as you can identify the serial number of the device in question.

The following shows the steps to follow after you have obtained a special license from the support staff of the regional headquarters of Canon.

- 1) Copy the set of special license files on the PC you are using for service work.  
Register the following with the Service Support Tool (SST): system file, language file, remote UI file, hard disk drive format file, MEAP contents file. (Be sure to pay attention to the version compatibility of individual files.)
- 2) Have the new hard disk drive at hand and replace it on site.  
While holding down the 2 and 8 keys at the same time, turn on the main power so that the machine will start up in download mode. The IP address 172.16.1.100 will automatically be used, which enables you to download files in high speed through a network.)
- 3) Using the SST, format the new HDD, and install the System, MEAP Contents, Language, and Remote UI files.
- 4) When the device has started normally, obtain the jar files of the MEAP applications from the user, and install them using the license files of the applications in the same way as you would when installing them for the first time.
- 5) As necessary, make login service selections and import user information.

---

#### Memo:

If you format the hard disk without uninstalling MEAP applications, always reinstall the applications previously installed. Unless reinstalling them, lots for the MEAP counters the applications use will not be released. The message "The number of applications that can be installed has exceeded the limit. Try to install this application after uninstalling other applications." may appear and the device does not accept to install new application. To install new applications, once reinstall the applications installed before formatting and uninstall unnecessary applications.

---

### 11.1.24 MEAP Safe Mode

iR5065 / iR 5055 / iR5075 / iR5075N / iR5065N / iR5055N

Use safe mode if you need to start up the system without worrying about extra applications. It will start up only those system software files (including SMS) that normally start up as default files while preventing MEAP applications and the like from starting up.

When you have made changes and turned off and then on the device, the control panel will indicate 'MPSF' in its lower right corner. The MEAP applications that may have been active before you shut down the equipment will not start up on their own. Make use of safe mode when restoring the system software as when MEAP applications or services cause a fault as the result of a conflict or wrong sequence of registration/use. You can access to SMS in this condition so that you can take necessary measures, for example, you can stop application that may cause the trouble.

If default authentication has been selected, the mode of authentication remains valid; otherwise, the message "The login service must be set again with SMS" appears. Change the login service as necessary.

#### Starting in Safe Mode

- 1) Start the device in service mode: click **Ad Func** key, press 2 and 8 buttons at the same time, and then click **Ad Func** key once again so that the service mode screen appears.
- 2) Press **COPIER** button.
- 3) Press **OPTION** button.
- 4) Press **USER**.
- 5) Press the right-arrow button.
- 6) Press **MEAPSAFE**.

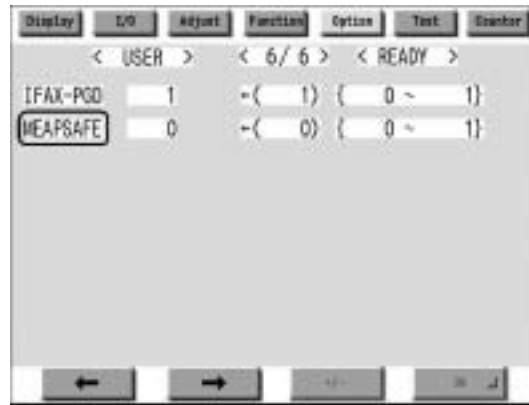

F-11-59

7) Press the 1 key on the control panel keypad to change the setting to '1'; then, click **OK** button.



F-11-60

8) Check that the notation 'MPSF' has appeared in the lower right corner of the screen; then, turn off and then on the main power.



F-11-61

If you want to end safe mode, repeat the steps but change '1' to '0' in step -7 and turn off and then on the main power.

### 11.1.25 Setting HTTP port for MEAP application (level 2)

iR5065 / iR 5055 / iR5075 / iR5075N / iR5065N / iR5055N

For the ports in which the MEAP application uses, the default is 8000 for the port on HTTP server, and 8443 for the port on HTTPS server. In the case that these ports have already used by the customer who is to introduce this application, the MEAP application cannot use the HTTP (or HTTPS) server(s). By changing the following ports to use, however, the MEAP application can be used as well as the existing system.

HTTP server

Setting value is 0 through 65535 [the value at factory shipment/after clearing RAM: 8000]

HTTPS server

Setting value is 0 through 65535 [the value at factory shipment/after clearing RAM: 8443]

#### Memo:

-As for port on HTTPS server, it only applies to the device that supports SSL function.

-Make sure not to use 1 through 1023 other than 80 (HTTP) as a port for MEAP. Because the ports in this range are used by general servers, there is a possibility that the ports in this range will be duplicated in the future.

<Setting Procedure of Port on HTTP server>

- 1) Startup [SERVICE MODE] (After pressing [USER MODE] button of MEAP device, press [2] button and [8] button at the same time on control panel. Then by pressing [USER MODE] button again, [SERVICE MODE] screen is displayed).
- 2) Startup level 2 of [SERVICE MODE] (After starting up [SERVICE MODE] in step 1, press [USER MODE] button again. Then, by pressing [2] button on control panel, the screen is displayed).
- 3) Press [COPIER] button.
- 4) Press [Option] button.
- 5) Press [BODY] button.
- 6) Press [←] button.
- 7) Press [MEAP-PN] button.

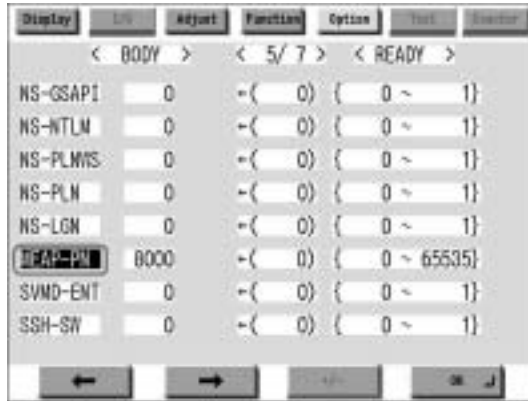

F-11-62

- 8) Press the port number to specify on the control panel (the numerical value input in the field is displayed), and press [OK] button.



F-11-63

- 9) Check to see that it is reflected in setting field, and turn off the main power, and then, turn on the main power.



F-11-64

<Setting Procedure of port on HTTPS server>

- 1) Startup [SERVICE MODE] (After pressing [USER MODE] button of MEAP device, press [2] button and [8] button at the same time on control panel. Then by pressing [USER MODE] button again, [SERVICE MODE] screen is displayed).
- 2) Startup level 2 of [SERVICE MODE] (After starting up [SERVICE MODE] in step 1, press [USER MODE] button again. Then, by pressing [2] button on control panel, the screen is displayed).
- 3) Press [COPIER] button.
- 4) Press [Option] button.
- 5) Press [BODY] button.
- 6) Press [-] button.
- 7) Press [MEAP-SSL] button.

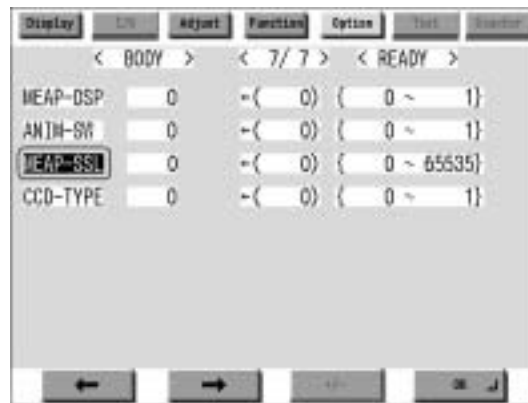

F-11-65

- 8) Press the port number to specify on the control panel (the numerical value input in the field is displayed), and press [OK] button.

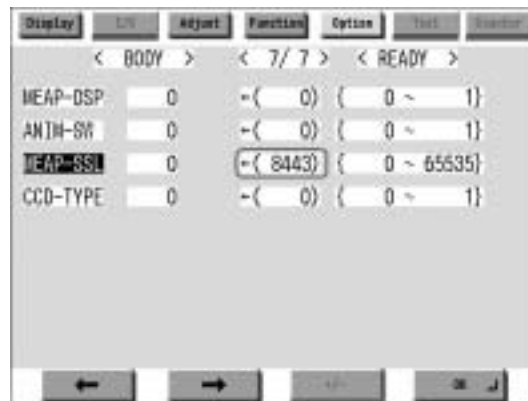

F-11-66

- 9) Check to see that it is reflected in setting field, and turn off the main power, and then, turn on the main power.

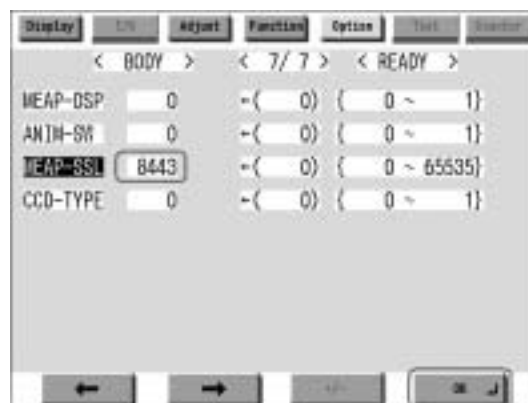

F-11-67

## 11.1.26 Reference material

iR5065 / iR 5055 / iR5075 / iR5075N / iR5065N / iR5055N

## Glossary

T-11-18

Terms & Acronyms	Definitions and Explanations
Applet	Applet Type Application. A Type of MEAP application that is designed to display user interface on device control panel.
Application	A software unit that provides a solution to users.
Application ID	A unique identifier assigned to each application. Used for indicating memory usage of the application in the MEAP system.
ASP	Application Service Provider. A business to provide the application service on Internet.
AVS	Applet Viewer Service. One of the MEAP system services that shows the user interface of the current applet type service on the console.
Code Sign	To attach Digital Signature to software code. MEAP has the mechanism to reject MEAP application without Code Sign for security reason.
CPCA	Common Peripheral Controlling Architecture. CPCA defines an object model of peripheral devices. A client can control a device by creating or modifying objects in the device.
CPCA Java CL	CPCA Java Class Library. A Java class library, which is used to control a device.
Default Authentication - Department ID Management	The login service used when the department ID control is used but other authentication controls are not used. When the Department ID control is turned on, the login dialog prompts the users to enter the department ID and password. The dialog appears the initial screen of both the control panel on the MEAP device and Remote UI
Device Specification ID	ID assigned for each device model. It shows the usage of functions that are equipped by MFP, as well as CPCA API specification and version numbers that is necessary for acquiring the values such as maximum number of copies, etc.
DIS	Dynamic Service Loading Installer Service. Receives data from the DSL on the MEAP platform. Enables an application to install to two or more devices.
DSL	Dynamic Service Loading. While the SMS installs a license file and application to one device, the DSL can install them to two or more devices. It consists of MEAP ESM and the DIS.
Esplet	Esplet Type Application. A type of MEAP application that does not have a user interface on the device console or on the web browser. The term of "Esplet" is a coinage by Canon inspired from Applet, Servlet, and "Espresso".
File descriptor	With a file descriptor, an OS identifies the files that a program accesses. The file descriptor includes information such as file name and size as well as the identifier. An OS determines files to operate with the identifier.
iR Native Application	The functionalities that existing imageRUNNER has such as Copy, Universal Send and Mailbox.
ISV	Independent Software Vender. Software manufacturer who develops and/or sells applications and tools but does not entire computer systems. Refers application developer in this document.
J2ME	Java 2 Platform Micro Edition. One of Java Platforms licensed by Sun Microsystems, Inc. It is applied for MEAP. Other devices such as cellular phones and PDA.
Java	A programming language developed by Sun Microsystems, in the U. S. A. Low dependent on models and OSES and runs on various platforms. Taking advantage of this feature, many applications that runs on web servers uses Java. The MEAP platform uses J2ME - a type of Java.
Java Script	A script language developed by Netscape Communications, in the U.S. A., runs on web browsers such as Netscape Navigator and Internet Explorer. Allows web designers to create interactive pages with HTML files such as animated buttons and display of timetables.
Java VM	JAVA Virtual Machine. The Java byte code interpreter. The Virtual Machine acts as an interpreter for processing the byte code using the native instruction set.
License Access Number	A number issued for accessing license file. The Licensing server requires entries of application ID, expiration date/times information, and the number of access numbers, to issue license access numbers.
License File	A software manufacture of a MEAP application provides the users with the license files. Specifies the terms of agreement that a user concludes with the manufacturer. Required for installing a MEAP application.
Login Service	Manages user information of MEAP device. Authenticates users with user names and passwords. Three login services are available for MEAP device - Default Authentication, which provides department ID control, SDL (Simple Device Login) and SSO (Single Sign-On).
MEAP	Multifunctional Embedded Application Platform. Provides an environment for executing application programs on a peripheral device. Uses the Java platform (J2ME - Java 2 platform Micro Edition) to run Java application for MEAP.
MEAP AMS	MEAP Application Management System. The license issuing server that issues "License File" necessary for MEAP applications to be installed onto MEAP device. Also used for issuing the "License Access Number".
MEAP Application	Runs on MEAP platform. Consists of application files (*.jar) and the license file (*.lic).
MEAP Contents	Required to install an MEAP application to a MEAP device.
MEAP ESM	MEAP Enterprise Service Manager. One of software programs composing the DSL, to be installed on a PC in a Windows environment. Works as the interface with the DSL.
MEAP Specifications	MEAP Spec Version, the term used for the SDK. The version number that shows the APIs of the MEAP platform other than CPCA, such as network and security. The version number is not assigned for each device model.
MEAP device	imageRUNNER (iR) device that has MEAP Platform incorporated.
MFP	Multi Function Peripheral. Peripheral device that supports more than one function, such as digital copier, printer, scanner, and fax.
OSGi	Open Service Gateway Initiative. See " <a href="http://www.osgi.org/">http://www.osgi.org/</a> ".
Portal Service	The service displayed on a Web browser by inputting the address " <a href="http://&lt;device IP address&gt;:8000/">http://&lt;device IP address&gt;:8000/</a> " or " <a href="http://&lt;device IP address&gt;/">http://&lt;device IP address&gt;/</a> " A portal to access a MEAP device from a Web browser.
Proxy Server	Provides functions to store data fetched from remote servers. When a user request to display a web page that has been displayed and stored in the proxy, the proxy server read the stored data but does not access the remote server where the original page is present, for efficient access services. When a proxy server receives a URL from a PC, it searches the file in the cache and sends it to the PC if the requested file is found. If the requested file is not stored in the cache, it accesses the remote server of the URL to acquire the file and, at the same time, stores the acquired file in the cache so that the proxy server can quickly send the file at the next request.

## Detail of License File

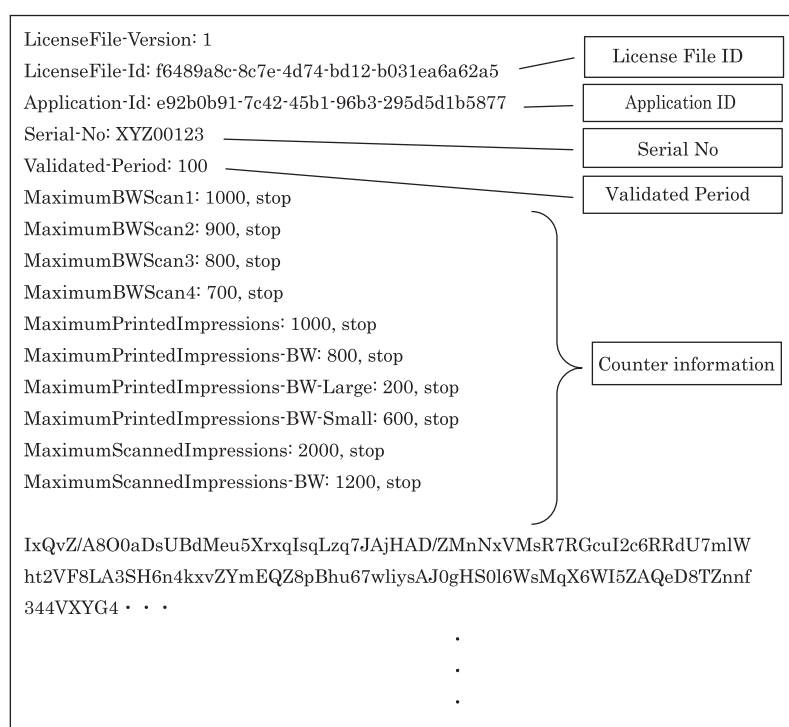

F-11-68

### 11.1.27 Option for exclusive individual measure

iR5065 / iR 5055 / iR5075 / iR5075N / iR5065N / iR5055N

#### -Display Setting of Copy Tab

Make a setting as to whether to display/hide the copy screen (copy tab) on the control panel. This is the specification for users who want to customize hiding it on control panel.

Default value

1: display

Setting range, item

0: hide 1: display

#### Setting Procedure

- 1) Startup [SERVICE MODE] (After pressing [USER MODE] button of MEAP device, press [2] button and [8] button at the same time on control panel. Then by pressing [USER MODE] button again, [SERVICE MODE] screen is displayed).
- 2) Press [COPIER] button.
- 3) Press [Option] button.
- 4) Press [BODY] button.
- 5) Press [←|or|→] (arrow) button.
- 6) Press [UI-COPY] button.
- 7) Press either 0 (hide) or 1 (display) on control panel (the numerical value input in the field is displayed), and press [OK] button.
- 8) Check to see that it is reflected in setting field, and turn off the main power, and then, turn on the main power.

#### -Error at starting up the MEAP application/Setting to hide JAM screen (level 2)

In the case that operation is restricted by MEAP application, hide the warning screen of error/JAM (such as JAM screen, door opening, no-toner). In the case that these errors occur, there will be a display indicating 'call the service personnel' etc.

#### Memo:

Part of the warning screens is displayed if shifting to the device screen.

- As for the screens for jam and no-toner, the warning screen (animation) can be displayed by pressing the followings: [Device Screen] > [Recovery Procedure]
- As for the screen for door opening, the warning screen cannot be displayed because there is no display for [[Device Screen] > [Recovery Procedure]

Default value

1: No activation of warning display

Setting range, item

0: display warning screen 1: hide warning screen

#### Setting Procedure

- 1) Startup [SERVICE MODE] (After pressing [USER MODE] button of MEAP device, press [2] button and [8] button at the same time on control panel. Then by pressing [USER MODE] button again, [SERVICE MODE] screen is displayed).
- 2) Startup level 2 of [SERVICE MODE] (After starting up [SERVICE MODE] in step 1, press [USER MODE] button again. Then, by pressing [2] button on control panel, the screen is displayed).
- 3) Press [COPIER] button.
- 4) Press [Option] button.
- 5) Press [BODY] button.
- 6) Press [←] or [→] button.
- 7) Press [ANIM-SW] button.
- 8) Press either 0 (display warning screen) or 1 (hide warning screen) on control panel (the numerical value input in the field is displayed), and press [OK] button.
- 9) Check to see that it is reflected in setting field, and turn off the main power, and then, turn on the main power.

#### -Setting of Screen Transition from MEAP Screen to the Standard Screen

In the case that the operation is restricted by MEAP application, make a setting to hide Native applications such as Copy/Send/Box. With this setting, disable screen transition with => key.

Default value

0: OFF (transit to Native screen)

Setting range, item

0: OFF (transit to Native screen) 1: ON (No-transition to Native screen)

#### Setting Procedure

- 1) Startup [SERVICE MODE] (After pressing [USER MODE] button of MEAP device, press [2] button and [8] button at the same time on control panel. Then, by pressing [USER MODE] button again, [SERVICE MODE] screen is displayed).
- 2) Startup level 2 of [SERVICE MODE] (After starting up [SERVICE MODE] in step 1, press [USER MODE] button again. Then, by pressing [2] button on control panel, the screen is displayed).
- 3) Press [COPIER] button.
- 4) Press [Option] button.
- 5) Press [BODY] button.
- 6) Press [←] (arrow) button.
- 7) Press [ANIM-DSP] button.
- 8) Press either 0 (transit to Native screen) or 1 (no-transition to Native screen) on control panel (the numerical value input in the field is displayed), and press [OK] button.
- 9) Check to see that it is reflected in setting field, and turn off the main power, and then, turn on the main power.



---

## Chapter 12 e-maintenance/imageWARE Remote

---



---

# Contents

12.1 e-maintenance/imageWARE Remote .....	12-1
12.1.1 Application operation mode.....	12-1
12.1.2 Service Center URL and Port Specification .....	12-1
12.1.3 Communication test .....	12-1
12.1.4 Communication log.....	12-1
12.1.5 Detailed Communication log .....	12-1
12.1.6 SOAP communication function .....	12-1
12.1.7 Resend at SOAP transmission error.....	12-2
12.1.8 e-RDS setting screen.....	12-2
12.1.9 Sleep operation.....	12-5
12.1.10 Network Setting (Maintenance).....	12-5
12.1.11 e-RDS Setting (Maintenance).....	12-5
12.1.12 Trouble shoot .....	12-6
12.1.13 Error message.....	12-6



## 12.1 e-maintenance/imageWARE Remote

### 12.1.1 Application operation mode

iR5065 / iR 5055 / iR5075 / iR5075N / iR5065N / iR5055N

Serviceman selects the operation mode of OFF/ON by the setting in e-RDS setting screen of the service mode. (Menu Screen: E-RDS)

- OFF (default): e-RDS doesn't operate.
- ON: e-RDS operates every function.

### 12.1.2 Service Center URL and Port Specification

iR5065 / iR 5055 / iR5075 / iR5075N / iR5065N / iR5055N

The URL and the port number of the equipment information destination can be specified as follows.

- Default (specified beforehand)
- Specified by the service mode. (Menu Screen: RGW-ADR, RGW-PORT)

### 12.1.3 Communication test

iR5065 / iR 5055 / iR5075 / iR5075N / iR5065N / iR5055N

Serviceman can distinguish the communication status with the UGW by executing the communication test in the service mode (Menu Screen: COM-TEST), and referring to the communication log

Error information is displayed in the latest communication log at communication error.

### 12.1.4 Communication log

iR5065 / iR 5055 / iR5075 / iR5075N / iR5065N / iR5055N

The list of the log of the communication error (proxy server error etc.)(For 30) can be displayed in display panel in the service mode. (Menu Screen: COM-LOG)

### 12.1.5 Detailed Communication log

iR5065 / iR 5055 / iR5075 / iR5075N / iR5065N / iR5055N

Detailed information of the error in the communication log can be displayed in display panel. (Log List Screen: Each error)

### 12.1.6 SOAP communication function

iR5065 / iR 5055 / iR5075 / iR5075N / iR5065N / iR5055N

The following processing is achieved by the SOAP communication (SSL client communication).

e-RDS does the host authentication by using the CA\*1 certificate of the VeriSign Co..

When the host certificate or the CA certificate is expired, e-RDS doesn't connect to UGW.

\*1: CA: Certificate Authority: Organization that issues electronic certificate used by electronic commerce etc

- (1) Communication test:
  - Do the communication test
- (2) Regularly collect the following data, and transmit it.
  - Copy Counter
  - Service mode counter
  - Parts counter
  - Mode Counter
  - ROM version
  - Scheduling information
  - Application log
- (3) When jam or alarm/service call error is detected from the device, e-RDS transmits to UGW.
  - Transmission of alert code(Counter information is transmitted at the same time.)
  - When the state of the device changes, e-RDS sends the alert code list.
  - The main alert codes used are Toner LOW/OUT, Jam, and Door open.
  - When recovering from an error, e-RDS transmits data that shows the recovering from an error again.
  - Transmission of Jam log (Counter information is transmitted at the same time.)
  - Transmission of Alarm log (Counter information is transmitted at the same time.)
  - Transmission of Service Call (Error code) log (Counter information is transmitted at the same time.)
- (4) Change of the device scheduling information
  - Scheduling information can be changed by the instruction from UGW.

List of Transmissions:

Content of transmission	Transmission timing
Communication test	When Service mode of device is executed
Copy counter collection/transmission	Every 6 hours
Service mode counter collection/transmission	Every 6 hours
Mode counter collection/transmission	Every 6 hours
Parts counter collection/transmission	Every 6 hours
ROM version transmission	Every 6 hours
Application log	When the log file size exceeds 10kbytes
Transmission of alert code	When the state of the device is changed.
Jam	When Jam occurs
Alarm	When Alarm occurs
Error	When Error occurs
Confirmation whether there is processing that e-RDS executes	Every 6 hours

### 12.1.7 Resend at SOAP transmission error

iR5065 / iR 5055 / iR5075 / iR5075N / iR5065N / iR5055N

When SOAP send error is generated by the trouble on UGW side etc. at the transmission of an alert code, the latest three batches of data that failed in the transmission are stored in HDD, and e-RDS resends it at prescribed intervals.

### 12.1.8 e-RDS setting screen

iR5065 / iR 5055 / iR5075 / iR5075N / iR5065N / iR5055N

The e-RDS setting screen is in the service mode screen.

When the tab above is selected on any e-RDS setting screen, it changes to the mid item screen. Moreover, it returns to previous screen when reset key is pressed.

Menu Screen

Display	I/O	Adjust	Function	Option	Test	Counter
<INSTALL >		< 1/ 1 >		< READY >		
TONER-S	<input type="text"/>					
STRD-POS	<input type="text"/>					
CARD	0	←( 0)	{ 1 ~ 2001}			
E-RDS	0	←( 0)	{ 0 ~ 1}			
RGW-PORT	443	←( 443)	{ 1 ~ 65535}			
COM-TEST	<input type="text"/>					
COM-LOG	<input type="text"/>					
RGW-ADR	https://a01.ugwdevice.net/ugw/agenti					
←		→		+/-		OK ↵

F-12-1

Setting screen of e-RDS. The form and the initial value of each setting item are as follows.

Item(meaning)	Explanation
E-RDS (Embedded-RDS)	Turning OFF/ON e-RDS. 0:OFF / 1:ON Counter information and error information are transmitted to the host at ON. Initial value: 0: OFF
RGW-ADR (RDS-Gateway ADDRESS)	URL of the host (When the input area is selected (touched), shift to the keyboard screen) Initial value: URL of an actual host. Length: 129 characters (NULL is contained)
RGW-PORT (RDS-Gateway PORT)	Port Number of the host Initial value: 443 Range of available number: 1-65535
COM-TEST (Communication Test)	Execution of Communication test Communication test starts when you select (touch) this and press the [OK] key. e-RDS tries the connection with the host, and displays the result by "OK!" or "NG!". (NG: No Good, the communication test is failed)
COM-LOG (Communication Log)	The result of communication test When this is selected (touched), and the blank rectangle on right side is selected, it switches to "Log list screen".

Log list screen

Display	I/O	Adjust	Function	Option	Test	Counter
<COM-TEST>		< 1 / 4 >		< READY >		
No.	DATE	TIME	CODE	Information		
01	2005 0129	1837	0500 0003	SUSPEND: Communicati		
02	2005 0129	1836	0500 0003	SUSPEND: Communicati		
03	2005 0129	1806	0500 0003	SUSPEND: Communicati		
04	2005 0129	1805	0500 0003	SUSPEND: Communicati		
05	2005 0129	1758	8000 2046	*Server certificate		
06	2005 0129	1750	0500 0003	SUSPEND: Communicati		
07	2005 0129	1743	0500 0003	SUSPEND: Communicati		
08	2005 0129	1722	0500 0003	SUSPEND: Communicati		
←		→		+/-		OK ↵

F-12-2

History list of communication test error (error generation date, error code and error information) is displayed.

When the each line is selected (touched), it shifts to "Log detailed screen".

It shifts to "Menu screen" by the [Function] > [INSTALL].

The list screen changes by a right arrow or a left arrow.

Maximum log number: 30

Notes: Only the first part of error information is displayed.



Log detailed screen

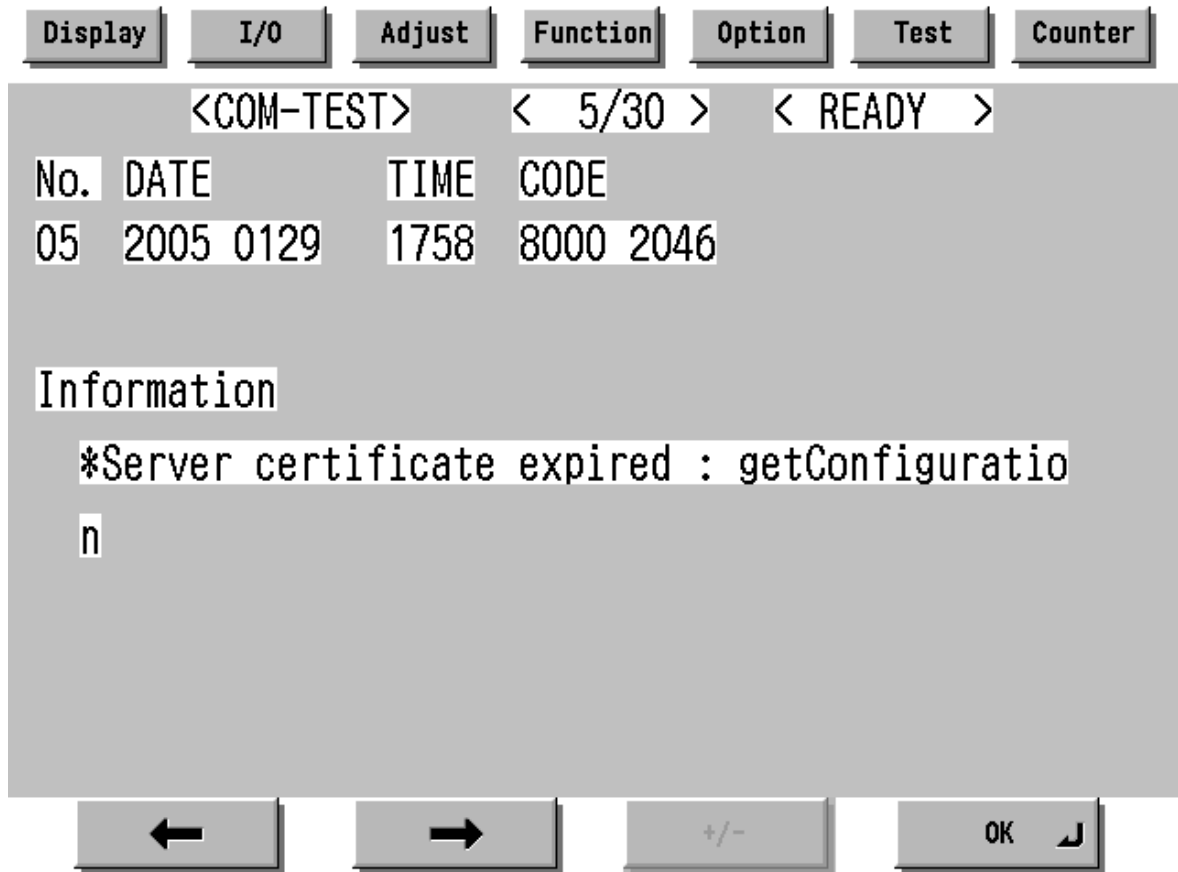

F-12-3

Detailed information of individual communication test error is displayed.  
 Refer to the displayed message to "Error message list".  
 It shifts to "Log list screen" by the [OK] button pressing.  
 Maximum length of error information: 128 characters (not include NULL)

### 12.1.9 Sleep operation

iR5065 / iR 5055 / iR5075 / iR5075N / iR5065N / iR5055N

When there is a method that should be transmitted while e-RDS is operating (ON), e-RDS wakes from the state of sleep and begins transmitting.

### 12.1.10 Network Setting (Maintenance)

iR5065 / iR 5055 / iR5075 / iR5075N / iR5065N / iR5055N

You should do the network setting of Device appropriately before the e-RDS setting.

- A. Display the Additional Functions screen.
  - Press [Additional Functions (\*)] key.
  - Input ID code.
- B. Display the TCP/IP Settings screen.
  - Select (touch) [System Settings] > [Network Settings] > [TCP/IP Settings] on the Touch Panel Display.
- C. Setting of items related to IP address
  - Select (touch) [IP Address Settings] => IP Address Settings screen is displayed.
  - Set each items such as IP Address, Subnet Mask, Gateway Addresses, and DHCP, etc.
  - Return to the TCP/IP Settings screen by pushing the [OK] button after the setting ends.
- D. DNS Settings
  - Select (touch) [DNS Settings] => DNS Settings screen is displayed.
  - Set necessary items.
  - Return to the TCP/IP Settings screen by pushing the [OK] button after the setting ends.
- E. Proxy Settings
  - Select (touch) [Proxy Settings] (Press Down arrow button until [Proxy Settings] is displayed on the TCP/IP Settings screen.) => Proxy Settings screen is displayed.
  - Set necessary items.
  - Return to the TCP/IP Settings screen by pushing the [OK] button after the setting ends.
- F. Display the normal screen.
  - Press [Additional Functions (\*)] key pressing or press [Done] button to a necessary frequency.

### 12.1.11 e-RDS Setting (Maintenance)

iR5065 / iR 5055 / iR5075 / iR5075N / iR5065N / iR5055N

- A. Display the Menu screen of e-RDS from the service mode.
  - A-1. Shift to the service mode

- Press [Additional Functions (\*)] key.
  - Press 2 and 8 of the numeric keys at the same time.
  - Press [Additional Functions (\*)] key. => SERVICE MODE LEVEL1
- A-2. Initialize e-RDS
- Select (touch) [COPIER] > [Function] > [CLEAR] > [ERDS-DAT] on the Touch Panel Display.
- A-3. Display Menu screen of e-RDS
- Select (touch) [COPIER] > [Function] > [INSTALL] => Menu screen

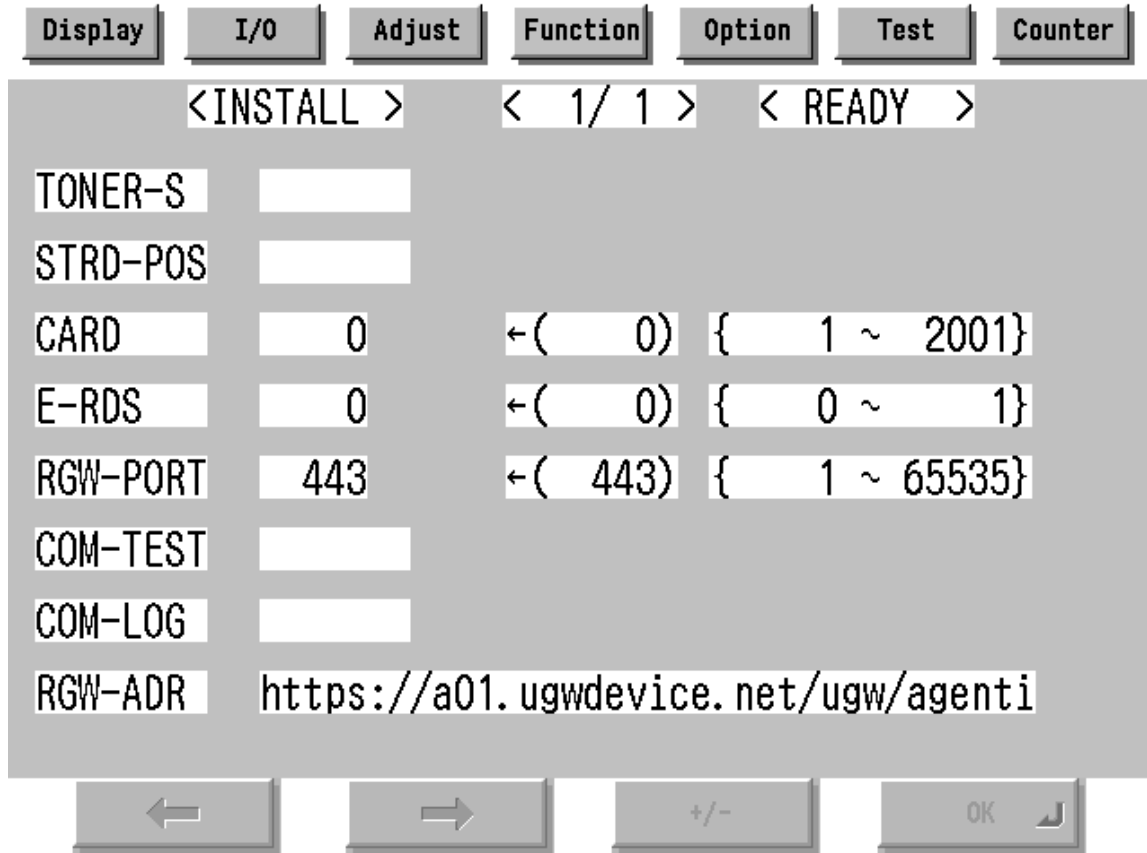

F-12-4

- B. Set 1 in [E-RDS].
- C. Input the URL of UGW in [RGW-ADR]. (Select the input area to shift to the keyboard screen, and Input URL.)
- D. Input the port number of UGW in [RGW-PORT].
- E. Select [COM-TEST] and push [OK] button to start the communication test with UGW.
- F. While the result is "NG!", repeat to correct the setting and try [COM-TEST] until the result becomes "OK!". You need checking the setting of the device and the connection of the network if necessary.
- Notes: In the environment with the proxy server, you should set the proxy server. Refer to the proxy setting in the network guide of the device for details.

### 12.1.12 Trouble shoot

iR5065 / iR 5055 / iR5075 / iR5075N / iR5065N / iR5055N

- 1-1
- Q. There is no setting item.
- A. Confirm the network setting.  
Confirm the model

- 1-2
- Q. The communication test fails.
- A. Confirm the firmware version.  
Confirm the network setting.  
Confirm the communication test result.

### 12.1.13 Error message

iR5065 / iR 5055 / iR5075 / iR5075N / iR5065N / iR5055N

Error information displayed in "Log list screen" or "Log detailed screen" is as follows.

Notes: Only the first part of error information is displayed in "Log list screen". Maximum length of error information in "Log detailed screen": 128 characters (not include NULL)

When the communication test is not completed end e-RDS is 1 (ON), following string is displayed:  
"SUSPEND: Communication test is not performed."

Moreover, when it fails in the event waiting in the device and either of a Jam notification, an Alarm notification, and a Service call notification or an Alert notification is specified, following string is displayed.

"Event Registration is Failed."

In other cases error information is displayed in the form of the following.

"[\*] [Error string]: [Method name] [Server side detailed error]"

The enclosed character string by [] is replaced as follows.

[\*]:

\*(asterisk) is added to the head of the string only at the communication test.

[Error string]:

As for number 1 and 2 of the following Error string lists, only the Error string is displayed. Besides, it is displayed as "[\*] [Error string]: [Method name] [Server side detailed error]". ([Server side detailed error] might not go out.)

	Error string	Cause	Counter Measure
1	SUSPEND: Communication test is not performed	The e-RDS is started (the device is rebooted) when e-RDS is ON and communication test isn't done.	Complete the communication test.
2	Event Registration is Failed.	The device failed event processing.	Turn OFF/ON of the device main switch. Or, replace the system software of the device (upgrade).
3	URL Scheme error (not https)	The header of registered URL of UGW is not https.	Change the header on URL of UGW to https
4	Server connection error	Communication failure of TCP/IP occurred. Or IP address of the device isn't set.	Check the network connection.
5	URL server specified is illegal	Illegal URL (other than UGW) is specified.	Correct URL.
6	Proxy connection error	The e-RDS cannot connect it with the proxy server.	Check and correct the proxy server address etc.
7	Proxy authentication error	The e-RDS fails the authentication to proxy.	Check and correct username and password to log in proxy.
8	Server certificate error	- The certificate is not installed in The device. - The certificate that The user is using is not registered in The device or The server.	Register the root certificate in the device or register the VeriSign certificate in the server.
9	Server certificate expired	- Expired certificate is registered in the device or the server. - The date of the device is outside the time limit of the certificate.	- Register the root certificate in expiration date in the device or register the VeriSign certificate in the server. - Set an accurate date to the device.
10	Unknown error	Other communication error occurs.	After waiting for a while, try again.
11	Server response error (NULL)	UGW returns the error but communication to UGW is succeeded. If (NULL) is displayed after the message, the error occurs in the HTTPS communication.	After waiting for a while, try again.
12	Server response error (Hexadecimal)	UGW returns the error but communication to UGW is succeeded. (Hexadecimal) displayed after the message is error code that UGW returns. [server side detailed error] is added at the end of error information only at this error.	After waiting for a while, try again.
13	Device internal error	Device internal error such as the memory cannot be taken occurs.	Turn OFF/ON of the device main switch. Or, replace the system software of the device (upgrade).
14	Server schedule is invalid	The schedule setting value given by UGW is found faulty at the time of communication test.	Report the detailed information of error occurrence to the support department. After the remedy by UGW, retry the communication test.
15	Server response time out	There was no reply from UGW in predetermined time. (The congestion of the network etc.) It is the timeout at HTTPS level.	After waiting for a while, try again.
16	Service not found	The URL of UGW is illegal, and UGW is inaccessible.	Check and correct the URL of UGW.

	Error string	Cause	Counter Measure
17	E-RDS switch is set OFF	You execute the communication test while the E-RDS switch is OFF.	Turn ON E-RDS switch, and execute the communication test.
18	Server schedule is not exist	The e-RDS receives empty schedule data from UGW.	Check setting file. (Call the help desk of UGW.)
19	Network is not ready, try later	You execute the communication when the connection to the network has not been established. (The network connection might not be established from the start-up of the device for 60 seconds.)	Confirm that the network connection has been established. Moreover, execute again after enough waiting.
20	URL error	Illegal URL (Syntax error etc.)	Correct URL.

## T-12-1

[Method name]:

	Method name	Meaning
1	postServiceModeCount	Account counter acquisition phase
2	postModeCount	Mode counter acquisition phase
3	postPartsCount	Parts counter acquisition phase
4	postFirmwareInfo	ROM version acquisition phase
5	getOperationList	Check/acquisition phase whether the information file for me is in UGW.
6	postOperationOutcome	
7	postConfiguration	Phase in which E-RDS configuration is transmitted to UGW
8	postGlobalClickCount	Counter acquisition phase
9	postJamLog	Jam notification acquisition phase
10	postServiceCallLog	Error notification acquisition phase
11	postAlert	Alert notification acquisition phase
12	postDebugLog	Log acquisition phase
13	getConfiguration	Information acquisition phase (Schedule transmission etc.)
14	communicationTest	Communication test phase

[Server side detailed error]:

Detailed error information returned from UGW is displayed for "Server response error".  
However, only the first 128 characters are displayed by the entire error information.  
Nothing is displayed here at other errors.

---

## Chapter 13 Maintenance and Inspection

---



---

# Contents

13.1 Periodically Replaced Parts .....	13-1
13.1.1 Outline.....	13-1
13.1.2 Reader Unit .....	13-1
13.1.3 Printer Unit.....	13-1
13.2 Durables and Consumables .....	13-1
13.2.1 Outline.....	13-1
13.2.2 Reader unit .....	13-2
13.2.3 Printer Unit.....	13-2
13.3 Scheduled Servicing Basic Procedure.....	13-2
13.3.1 Scheduled Servicing Basic Procedure .....	13-2
13.3.2 Periodical Servicing Chart Reader Unit.....	13-3
13.3.3 Periodical Servicing Chart Printer Unit .....	13-4
13.3.4 Points to Note for Periodical Servicing .....	13-5
13.4 Cleaning .....	13-6
13.4.1 Cleaning Primary Toner Blocking Sheet .....	13-6
13.4.2 Cleaning Developing Toner Blocking Sheet .....	13-6
13.4.3 Cleaning Cleaner Scraper .....	13-6
13.4.4 Cleaning Photosensitive Drum .....	13-7
13.4.5 Cleaning the fixing oil dish and the fixing cleaning belt guide .....	13-8





## 13.1 Periodically Replaced Parts

### 13.1.1 Outline

iR5065 / iR 5055 / iR5075 / iR5075N / iR5065N / iR5055N

Some parts of the machine must be replaced on a periodical basis for the machine to maintain a specific level of performance. They must be replaced regardless of the presence/absence of external changes or damage, as the performance of the machine will be considerably affected once they fail. If possible, plan any replacement to coincide with a scheduled visit.



The intervals indicated may vary depending on the site environment and user habit.

#### - Checking the Timing of Replacement

The timing of replacement may be checked using the following service mode items:

COPIER > COUNTER > PRDC-1

### 13.1.2 Reader Unit

iR5065 / iR 5055 / iR5075 / iR5075N / iR5065N / iR5055N

The reader unit does not have parts that require periodical replacement.

### 13.1.3 Printer Unit

iR5065 / iR 5055 / iR5075 / iR5075N / iR5065N / iR5055N

T-13-1

As of December 2006

No.	Part name	Part No.	Q'ty	Life	Remarks
1	Primary, pre-transfer, transfer, separation charging wire	FB4-3687-000	AR	500,000 (*)	
2	Primary grid wire	FY1-0883-000	AR	500,000	
3	thermistor unit	FK2-5252-000	1	500,000	Main thermister + shutter thermister
4	Sub thermistor	FM2-4161-000	1	500,000	
5	Primary charging wire cleaner 1	FL2-4271-000	1	500,000	
6	Primary charging wire cleaner 2	FL2-4272-000	2	500,000	
7	Transfer charging wire cleaner 1	FL2-4271-000	1	500,000	
8	Transfer charging wire cleaner 2	FL2-4272-000	1	500,000	
9	Separation charging wire cleaner	FF5-3090-000	2	500,000	
10	Pre-transfer charging wire cleaner	FF5-3090-000	1	500,000	
11	Air filter 1	FC6-3482-000	1	500,000	
12	Air filter 2	FC6-3483-000	1	500,000	
13	Ozone filter	FC6-3693-000	1	500,000	

\*: Do not use the old type (gold plated). After replacement of the charge wire, be sure to execute wire cleaning in service mode. (COPIER > FUNCTION > CLEANING > WIRECLN)

T-13-2

#### Chemical replaced parts

As of December 2006

No.	Part name	Part No.	Q'ty	Life	Remarks
1	Photosensitive Drum	F43-7801-000	1	3,000,000	
2	Collecting toner bottle	F42-7901-000/ F42-7911-000/ F42-7921-000	1	44,000(TBD)	6% original :0.050g/A4 1Copy(TBD)

## 13.2 Durables and Consumables

### 13.2.1 Outline

iR5065 / iR 5055 / iR5075 / iR5075N / iR5065N / iR5055N

Some parts of the machine may have to be replaced once or more over the period of machine warranty because of wear or damage. Replace them as needed by referring to the table of estimated lives (expressed in terms of the number of prints they make).

#### Making Checks When Replacing Durables

Use the following service mode items to find out when to replace parts:

- Machine  
**COPIER > COUNTER > DRBL-1**  
 - Accessory  
**COPIER > COUNTER > DRBL-2**

### 13.2.2 Reader unit

iR5065 / iR 5055 / iR5075 / iR5075N / iR5065N / iR5055N

The reader unit does not have parts that are classified as "consumables" or "durables."

### 13.2.3 Printer Unit

iR5065 / iR 5055 / iR5075 / iR5075N / iR5065N / iR5055N

T-13-3

As of December 2006

No.	Part name	Part No.	Q'ty	Life	Remarks
1	Developing cylinder	FM2-9641-000	1	1,000,000	
2	Developing assembly roll	FB6-6569-000	2	1,000,000	
3	Cleaner separation claw	FB2-6899-000	3	500,000	
4	Cleaning blade	FA6-3995-000	1	1,000,000	Both edges are used; each for 500,000; apply toner upon replacement
5	Primary corona assembly	FM2-3069-000	1	1,000,000	
6	Transfer/separation corona assembly	FM2-9716-000	1	1,000,000	
7	Pre-transfer corona assembly	FM2-9647-000	1	1,000,000	
8	Pre-separation charging assembly scraper	FA4-1867-000	1	500,000	
9	Fixing roller	FC4-4274-000	1	500,000	*1
10	Pressure roller	FC7-4237-000 FC7-4236-000(JPN only)	1	500,000	*2
11	Fixing web	FY1-1157-000	1	500,000	
12	Pressure roller bearing	XG9-0636-000	2	500,000	
12	Insulating bushing (front/rear)	FC6-3502-000	2	500,000	*3
13	Static eliminator (pressure roller)	FC7-4287-000	1	500,000	
14	Delivery upper separation claw	FB5-3625-000	6	500,000	
15	Delivery lower separation claw	FA2-9037-000	2	1,000,000	
16	Pickup roller rear	FF5-7830-000	4	500,000	Real use number of sheets (Each holder uses 1 pc.)
17	Pickup roller front	FF5-7829-000	4	500,000	Real use number of sheets (Each holder uses 1 pc.)
18	Pickup/feeding roller (deck, cassette)	FB6-0615-000	4	500,000	Real use number of sheets (Each holder uses 2 pc.)
19	Separation roller (deck, cassette)	FB5-6586-000	4	500,000	Real use number of sheets (Each holder uses 1 pc.)
20	Pickup/feeding roller (manual feed roller)	FB1-8581-000	1	120,000	Real use number of sheets
21	Separation roller (manual feed roller)	FB5-0873-000	1	120,000	Real use number of sheets



\*1 As the fixing roller is used more and more, its surface tends to become discolored because of heat. The change, however, will not affect the performance of the roller. Also, note that the roller surface varies in color among manufacturers and the fact will not affect the roller performance.

\*2 Replace this also at the time when replacing the pressure roller bearings. Before attaching the bearings, apply the grease (Molykote HP300) uniformly around the outer circumference of the pressure roller shaft. Apply about 2 drops of the grease each on the front and rear sides of the shaft.

\*3 Replace simultaneously with fixing roller. When you replace bushings, apply about 20 mg of grease (Molykote HP-300; CK-8012) on the inner and outer surfaces of the bushing until there is a white coating covering the entire sources.

## 13.3 Scheduled Servicing Basic Procedure

### 13.3.1 Scheduled Servicing Basic Procedure

iR5065 / iR 5055 / iR5075 / iR5075N / iR5065N / iR5055N



- As a rule, provide scheduled servicing every 250,000 prints.
- Check with the Service Book before setting out for a scheduled service visit, and take parts for which replacement is expected.
- If the power plug is left connected for a long time in a place subject to dust, humidity, or oil smoke, a fire hazard is a possibility (i.e., the dust collecting around the plug can absorb moisture, resulting in insulating failure). Be sure to disconnect the power plug on a periodical basis, and wipe off the dust and dirt collecting around it.

<Work Procedure>

- 1) Report to the person in charge, and check the general condition.
- 2) Record the counter reading, and check the faulty prints.
- 3) Make the following checks, and clean/adjust the items that are indicated:

T-13-4

**Items**

Test copy	against image density standard	
	for soiling of back of paper	
	for clarity of characters	
	for margin	
	for fixing	misplaced registration, soiled back of paper
	for margin standards (single-sided print)	leading edge: 4.0+1.5/-1.0mm left edge: 2.5+/- 1.5mm
	(double-sided print)	leading edge: 4.0+1.5/-1.0mm left edge: 2.5+/- 2.0mm

- 4) Check the waste toner case.  
If half full or more, dispose of the waste toner in a vinyl bag or the like for collection; or, replace the waste toner case.



- If you need to dispose of the waste toner, be sure to do so in strict accordance with the regulations imposed by the local authorities.
- Do not dispose of waste toner in a fire. Doing so may cause an explosion.

- 5) Clean the copyboard glass and the reading glass.
- 6) Make test copies.
- 7) Make sample copies.
- 8) Check the operation of the leakage breaker.  
With the power switch at ON, push the test switch of the leakage breaker to see that it operates normally (i.e., the breaker switch shifts to the OFF side to cut off the power).  
If the leakage breaker fails to operate normally, replace it, and run a check once again.

<Resetting the Breaker>

When you have made the check, turn off the main power switch, and turn on the breaker switch, and then turn the main power switch back on.

- 9) Put the sample copies in order, and clean up the area around the machine.
- 10) Record the final counter reading.
- 11) Fill out the Service Book, and report to the person in charge. Be sure to update the history of checks on the leakage breaker in the Service Book.

**13.3.2 Periodical Servicing Chart Reader Unit**

iR5065 / iR 5055 / iR5075 / iR5075N / iR5065N / iR5055N



Do not use solvents or oils other than those indicated.

T-13-5

Unit	Location	Intevals	Remarks
		as needed	

Original exposure system	Copyboard glass	clean	
	ADF reading glass	clean	
	Scanner rail	clean/lubricate	Silicone oil (FY9-6011)
	Scanner mirror (No.1 through No.3 mirrors)	clean	
	Reflecting plate	clean	

### 13.3.3 Periodical Servicing Chart Printer Unit

iR5065 / iR 5055 / iR5075 / iR5075N / iR5065N / iR5055N



Do not use solvents or oils other than those indicated.

T-13-6

Unit name	Part	Intervals				Remarks
		Upon installation	every 250,000	every 500,000	every 1,000,000	
Externals/ controls	Ozone filter			Replace		
	Air filter 1			Replace		
	Air filter 2			Replace		
	Dust-proofing filter (primary)		Clean			Remove dust from surface.
Laser optical path	Dust-proof glass		Clean			
Charging assembly	Charging wire (primary, pretransfer, transfer/separation)	Clean		Replace		After replacement, execute wire cleaning 5 times.
	Charging wire cleaner (primary, pretransfer, transfer/separation)			Replace		Replace with charging wire simultaneously.
	Grid wire (primary)	Clean	Clean	Replace		
	Charging assembly shielding plate (each charging assembly)	Clean	Clean			
	Primary antistray toner sheet		Clean			
	Roller electrode	Clean	Clean			
Photosensitive drum	Photosensitive drum		Clean			Use alcohol and drum cleaning powder (CK-0429).
	Electrode (for slip ring of drum heater)				Clean / Lubricate	Clean with alcohol; 1) electrode, 2) protruding wall of electrode (where FY9-6008 is applied). - Charge collecting brush
	Drum separation claw		Clean	Replace		In a high temperature and high pressure environment, replaces it by 250,000
Developing assembly	Developing cylinder	Inspect				
	Developing assembly roll		Clean			
	Anti stray toner sheet		Clean			
Cleaner	Side scraper			Clean		
	collecting toner bottle holder		Clean			

Unit name	Part	Intervals				Remarks
		Upon installation	every 250,000	every 500,000	every 1,000,000	
Fixing assembly	Inlet guide		Clean			
	Web	Inspect				
	Oil dish			Clean		
	Web guide			Clean		
	Thermistor unit		Clean	Replace		
	Sub thermistor		Clean	Replace		
	left stay		Clean			Both sides driving shaft
	Static eliminator (pressure roller)			Replace		
Delivery assembly	Separation claw (upper, lower)		Clean			
	Internal delivery roll		Clean			
	External delivery roll		Clean			
Toner collection area	Collecting toner box		Inspect			Inspect case, and remove toner.
Pickup/ feeding assembly	Transfer guide		Clean			
	Registration roller (upper, lower)		Clean			
	Feeding belt		Clean			
	Feeding rollers		Clean			

**13.3.4 Points to Note for Periodical Servicing**

iR5065 / iR 5055 / iR5075 / iR5075N / iR5065N / iR5055N

Unless otherwise instructed, clean with lint-free paper and alcohol.



- Make a thorough check of the block (front, rear) for melting by leakage, deformation by heat, cracking, discoloration (yellowing). If a fault is found, replace the part with a new one immediately.
- Check the block (front, rear) including its inside.
- Do not use a cloth on which metal powder is found.
- If you have used solvent, make sure that the part has dried completely before mounting it back to the machine.
- Do not use a moist cloth unless specifically indicated.
- Be sure to provide scheduled servicing/replacement at the specified intervals.

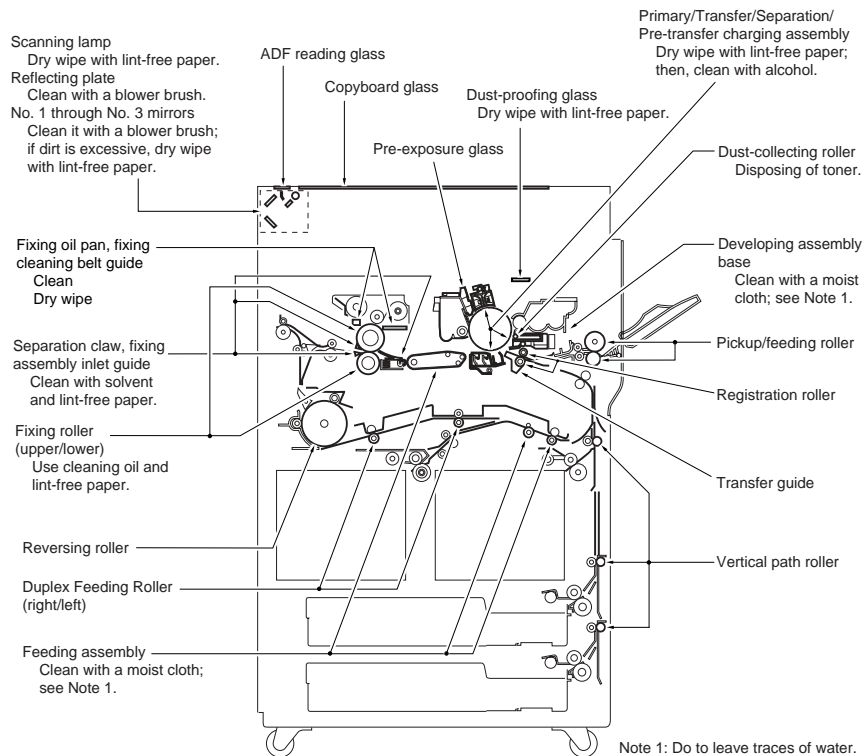

F-13-1

## 13.4 Cleaning

### 13.4.1 Cleaning Primary Toner Blocking Sheet

iR5065 / iR 5055 / iR5075 / iR5075N / iR5065N / iR5055N

- 1) Remove the process unit.
- 2) Remove the potential sensor rail stay [2].  
- 2 screws [1]

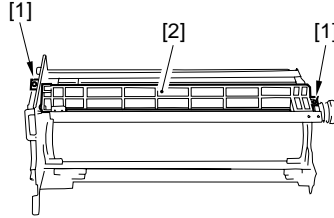

F-13-2

- 3) Clean the primary toner blocking sheet [1].

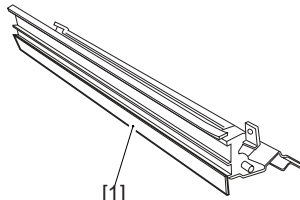

F-13-3

### 13.4.2 Cleaning Developing Toner Blocking Sheet

iR5065 / iR 5055 / iR5075 / iR5075N / iR5065N / iR5055N

- 1) Remove the developing assembly, and clean the developing toner blocking sheet [1].

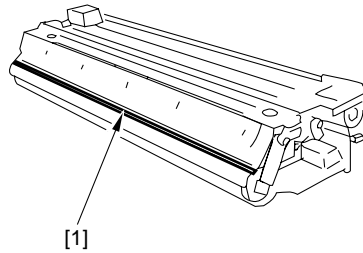

F-13-4

### 13.4.3 Cleaning Cleaner Scraper

iR5065 / iR 5055 / iR5075 / iR5075N / iR5065N / iR5055N

- 1) Remove the cleaning blade.
- 2) Remove any paper lint accumulated at the tip of the cleaner scraper (A; the area between the magnet roller and the toner guide roller) with tweezers.
- 3) Remove the toner from the surface of the magnet roller. (Roll a paper into a U-shape to scoop it up.)

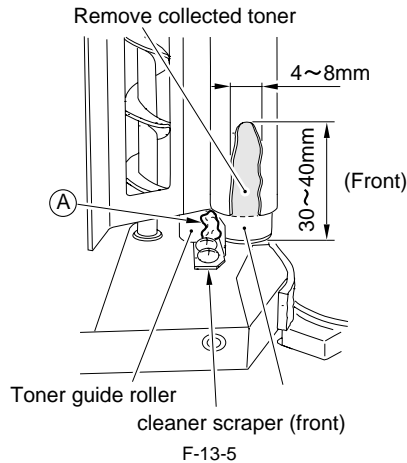

F-13-5

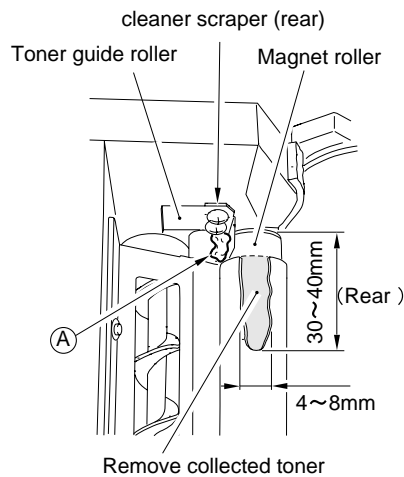

F-13-6

- 4) Rotate the magnet roller in the clockwise direction (viewing from the front).
- 5) Repeat the step 3 through 4 until the area from which toner was removed in the step 3 is once again coated with an even layer of toner.

#### 13.4.4 Cleaning Photosensitive Drum

iR5065 / iR 5055 / iR5075 / iR5075N / iR5065N / iR5055N



Do not rotate the magnet roller during work. Otherwise, waste toner may fall through the cleaner assembly.

- 1) Remove the process unit.
- 2) Remove the photosensitive drum.
- 3) Moisten lint-free paper [1] with 5 to 10 cc of alcohol solutions [2]; then, pour 0.2 to 0.3 g of the drum cleaning powder (CK-0429) [3] on the lint-free paper.
- 4) While butting the lint-free paper relatively strongly against the photosensitive drum, wipe the surface of the drum from the front to the rear and from the rear to the front.

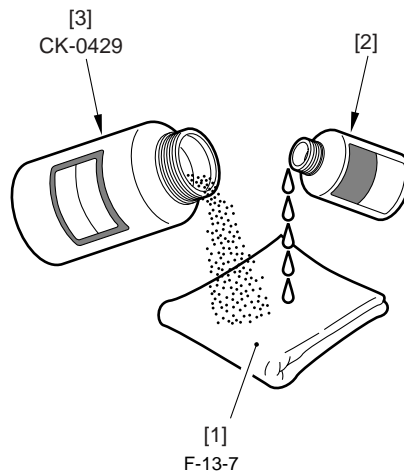

F-13-7



- Keep the widths of cleaning to 5 to 10 cm in the peripheral direction of the drum.
- Move the lint-free paper back and forth 15 to 20 times over a single area. Forcing the lint-free paper will not affect the life of the drum.

- 5) After the alcohol has evaporated, dry wipe the surface with the lint-free paper. If the area is uneven, go back to the step 4, and increase the back-and-forth movements.
- 6) Rotate the drum for the width (5 to 10 cm), and repeat the step 3 through 5 until the entire area of the surface has been cleaned.

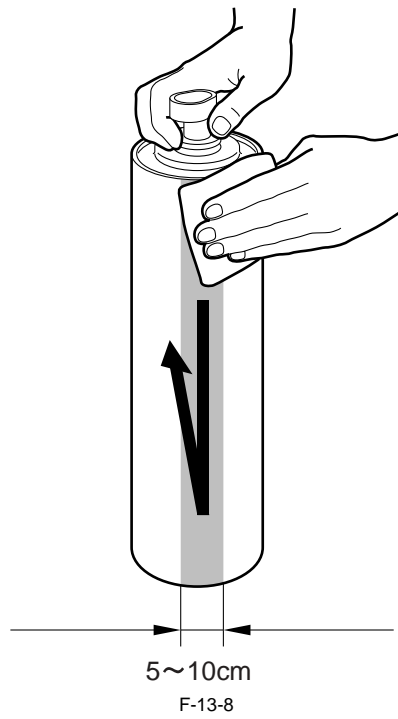

### 13.4.5 Cleaning the fixing oil dish and the fixing cleaning belt guide

iR5065 / iR 5055 / iR5075 / iR5075N / iR5065N / iR5055N

- 1) Detach the fixing web.
- 2) Clean the surface of the silicone oil tray [1].
- 3) Clean the surface of the fixing cleaning web guide [2].

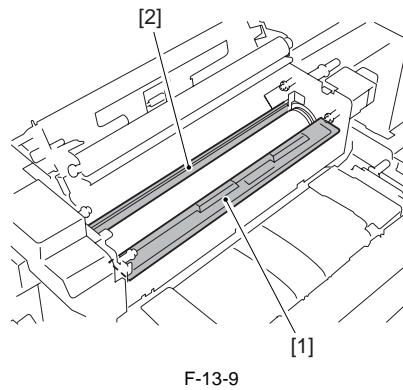



---

## Chapter 14 Standards and Adjustments

---



---

# Contents

14.1 Image Adjustment Basic Procedure .....	14-1
14.1.1 Making Pre-Checks .....	14-1
14.1.2 Making Checks on the Printer Unit (1/2) .....	14-1
14.1.3 Making Checks on the Printer Unit (2/2) .....	14-3
14.1.4 Making Checks on the Reader Unit .....	14-4
14.1.5 Checking the Potential System .....	14-7
14.1.6 Checking the Surface Potential Control System .....	14-9
14.1.7 Potential Control System Conversion Table .....	14-11
14.1.8 Emergency Measures for a Fault in the Potential Sensor .....	14-16
14.2 Image Adjustments .....	14-17
14.2.1 Standards of Image Position .....	14-17
14.2.2 Checking the Image Position .....	14-17
14.2.3 Adjusting Side Registration .....	14-17
14.2.4 Adjusting the Image Leading Edge Margin .....	14-18
14.2.5 Adjusting the Left/Right Non-Image Width .....	14-18
14.2.6 Adjusting the Leading Edge Non-Image Width .....	14-18
14.3 Scanning System .....	14-19
14.3.1 After Replacing the Reader Controller PCB .....	14-19
14.3.2 When Replacing the CCD Unit .....	14-19
14.3.3 Adjusting the Position of the No. 1/No. 2 Mirror Base .....	14-19
14.3.4 When Replacing the Copyboard Glass .....	14-20
14.3.5 When Replacing the Reading Glass .....	14-20
14.3.6 When Replacing the Scanning Lamp .....	14-20
14.3.7 After Replacing the Inverter PCB .....	14-20
14.4 Laser Exposure System .....	14-20
14.4.1 When Replacing the Scanner Unit .....	14-20
14.5 Image Formation System .....	14-20
14.5.1 Outline .....	14-20
14.5.2 Routing Charging Wire .....	14-20
14.5.3 Routing Grid for Primary Charging Assembly .....	14-21
14.5.4 Adjusting Height of Charging Wire .....	14-21
14.5.5 Mounting Cleaning Blade .....	14-22
14.5.6 Removing Side Seal .....	14-22
14.6 Fixing System .....	14-22
14.6.1 Applying Grease After Replacing the Fixing Roller .....	14-22
14.6.2 Adjusting the Nip Width .....	14-23
14.6.3 Adjusting the Fixing Web Solenoid (SL9) .....	14-23
14.6.4 After Replacing the Fixing Web .....	14-23
14.6.5 Adjusting the Fixing Inlet Guide Solenoid (SL1) .....	14-23
14.6.6 Adjusting the Position of the Fixing Inlet Guide .....	14-23
14.7 Electrical Components .....	14-23
14.7.1 When Replacing DC Controller PCB .....	14-23
14.7.2 When Replacing HVT PCB .....	14-24
14.7.3 After Replacing the HDD .....	14-24
14.7.4 When Replacing the Main Controller PCB .....	14-24
14.8 Pickup/Feeding System .....	14-24
14.8.1 Points to Note When Mounting the Pickup Roller .....	14-24
14.8.2 Points to Note When Mounting the Separation Roller .....	14-24
14.8.3 The Points to Mount the Feeding Roller .....	14-24
14.8.4 Adjusting the Pressure of the Deck/Cassette Separation Roller .....	14-25

14.8.5 Adjusting the Pressure of the Manual Separation Roller.....	14-25
14.8.6 Adjusting the Position of the Pickup Solenoid (SL3, SL4) of the Cassette 3/4.....	14-25
14.8.7 Adjusting the Position of the Delivery Flapper Solenoid (SL5).....	14-25
14.8.8 Adjusting the Position of the Right Deck Pickup Solenoid (SL6).....	14-25
14.8.9 Adjusting the Position of the Left Deck Pickup Solenoid .....	14-26
14.8.10 Mounting the Reversing Flapper Solenoid .....	14-26
14.8.11 Attaching the Side Guide Timing Belt in the Manual Feed Tray Assembly .....	14-26
14.8.12 Adjusting the Position of the Lifter Motor M20/M21 of the Cassette 3/4.....	14-26

## 14.1 Image Adjustment Basic Procedure

### 14.1.1 Making Pre-Checks

iR5065 / iR 5055 / iR5075 / iR5075N / iR5065N / iR5055N



#### Points to Note When Making a Check on the Printer Side

The machine's potential control mechanisms consist of those for copier image output and those for printer (PDL) image output, and permit independent adjustment of service mode potential control parameters.

If an image fault occurs, be sure to first find out which is at fault, prepare an image (data) accordingly, and then make appropriate adjustments.

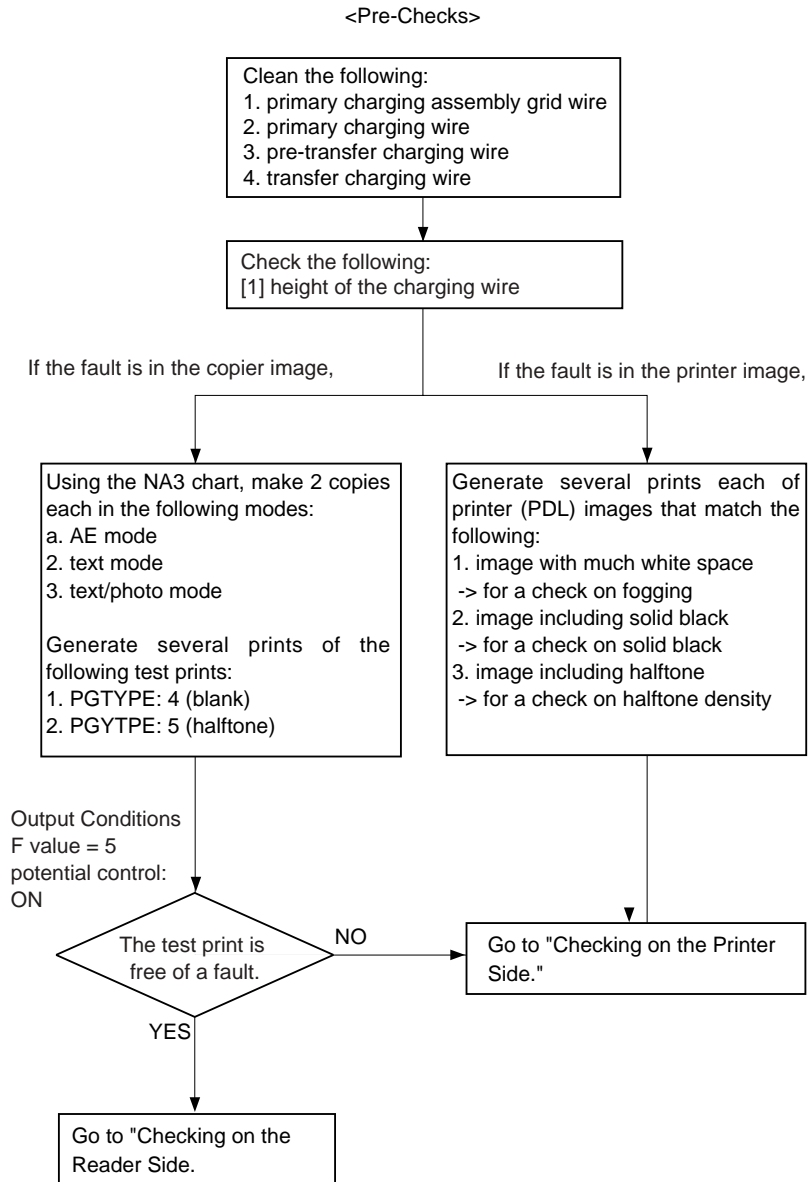

F-14-1

COPIER > TEST > PG > TYPE  
COPIER > OPTION > BODY PO-CNT

### 14.1.2 Making Checks on the Printer Unit (1/2)

iR5065 / iR 5055 / iR5075 / iR5075N / iR5065N / iR5055N

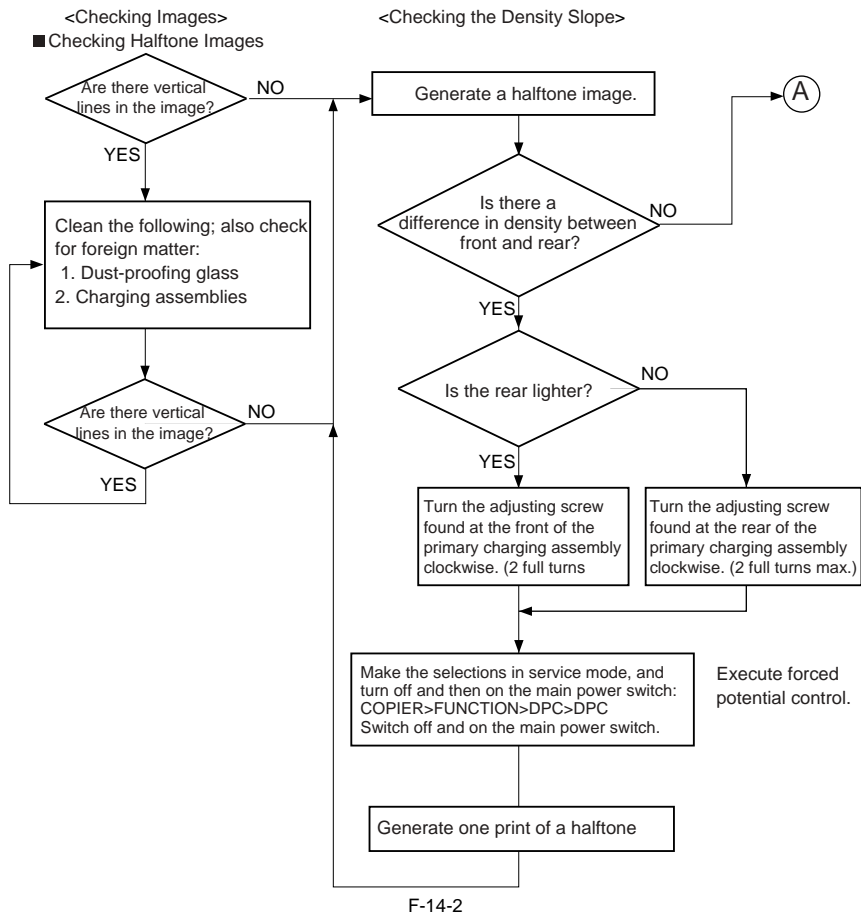

COPIER > FUNCTION > DPC > DPC



1. If there still is a difference in density after giving the adjusting screw 2 turns (each turn causing a change of about 0.7 mm), check the scanning lamp and the scanner for soiling.
2. When making a clockwise turn, be sure that the intervals between wire grid runs are not larger than 9 mm.  
When making a counterclockwise turn, be sure that the intervals between wire grid runs are not smaller than 7.5 mm.

**MEMO:**

Moving the wire from the photosensitive drum causes the image to be lighter, while moving it closer causes the images to be darker.

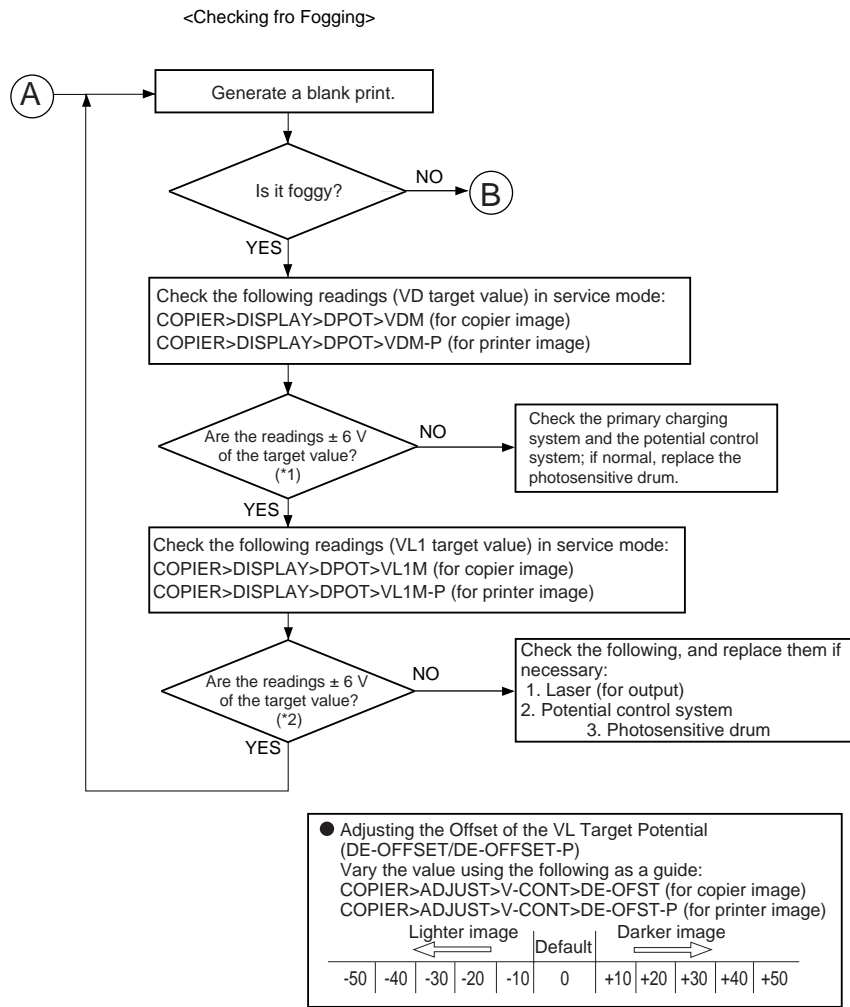

F-14-3

COPIER > DISPLAY > DPOT > VDM  
 COPIER > DISPLAY > DPOT > VDM-P  
 COPIER > DISPLAY > DPOT > VL1M  
 COPIER > DISPLAY > DPOT > VL1M-P  
 COPIER > ADJUST > V-CONT > DE-OFST  
 COPIER > ADJUST > V-CONT > DE-OFS-P

**14.1.3 Making Checks on the Printer Unit (2/2)**

iR5065 / iR 5055 / iR5075 / iR5075N / iR5065N / iR5055N

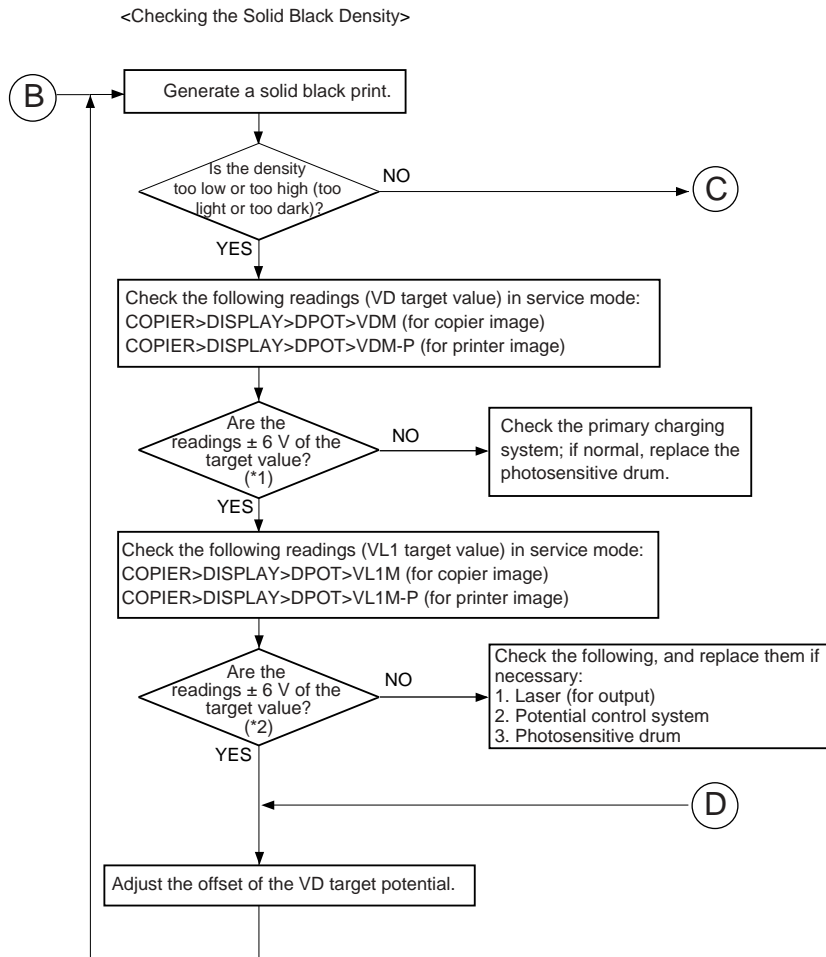

F-14-4

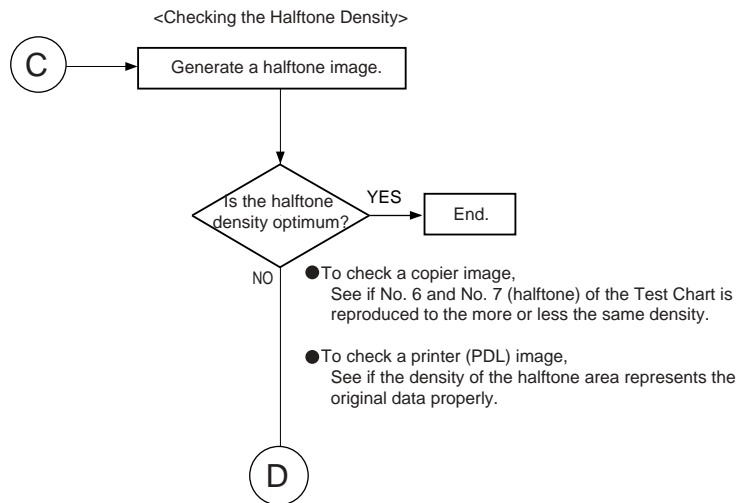

● Adjusting the Offset Value of the VD Target Potential (VD-OFFSET/VD-OFFSET-P)  
 COPIER>ADJUST>V-CONT>VD-OFST (for copier image)  
 COPIER>ADJUST>V-CONT>VD-VD-OFST-P (for printer image)

Lighter image	←	Default	→	Darker image						
-5	-4	-3	-2	-1	0	+1	+2	+3	+4	+5

F-14-5

#### 14.1.4 Making Checks on the Reader Unit

iR5065 / iR 5055 / iR5075 / iR5075N / iR5065N / iR5055N



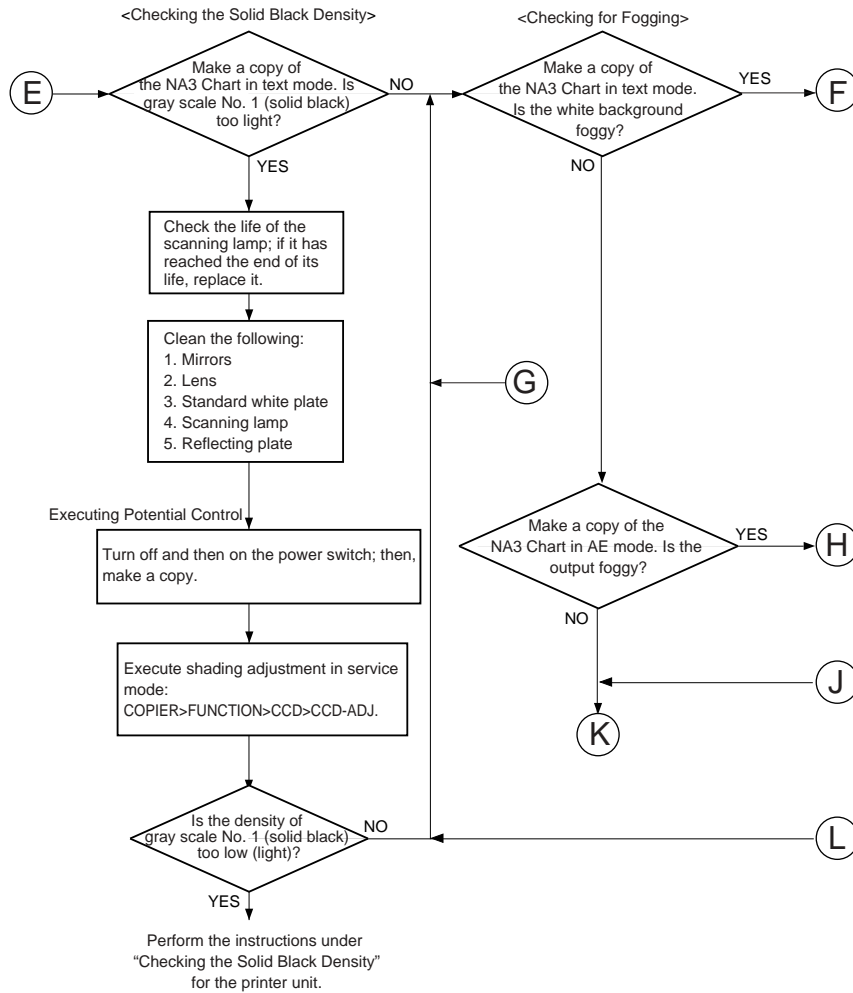
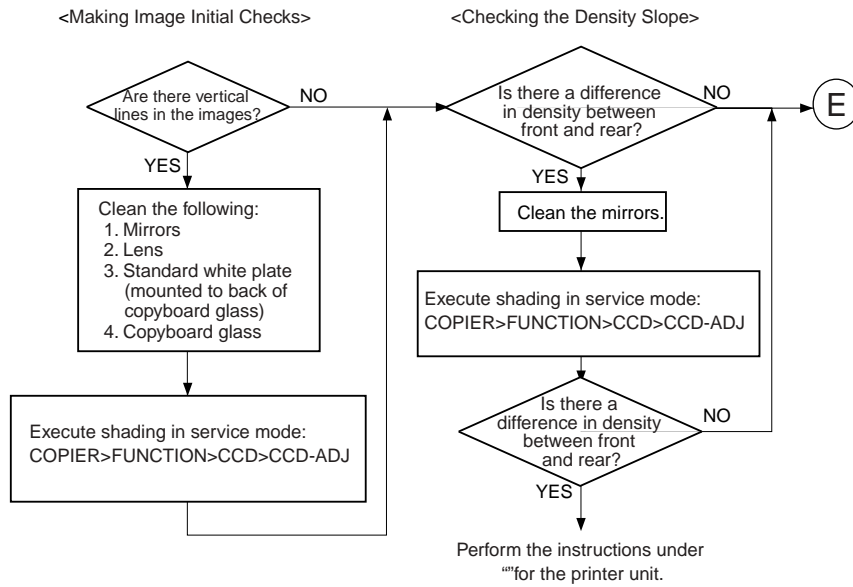

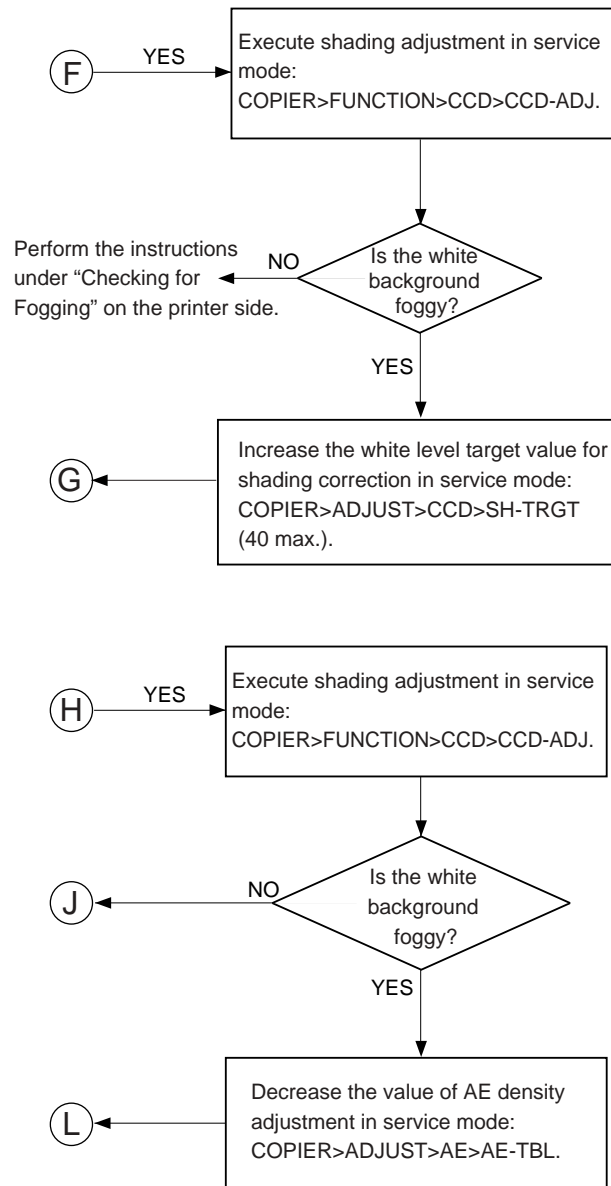

F-14-8

## &lt;Checking Halftone Density&gt;

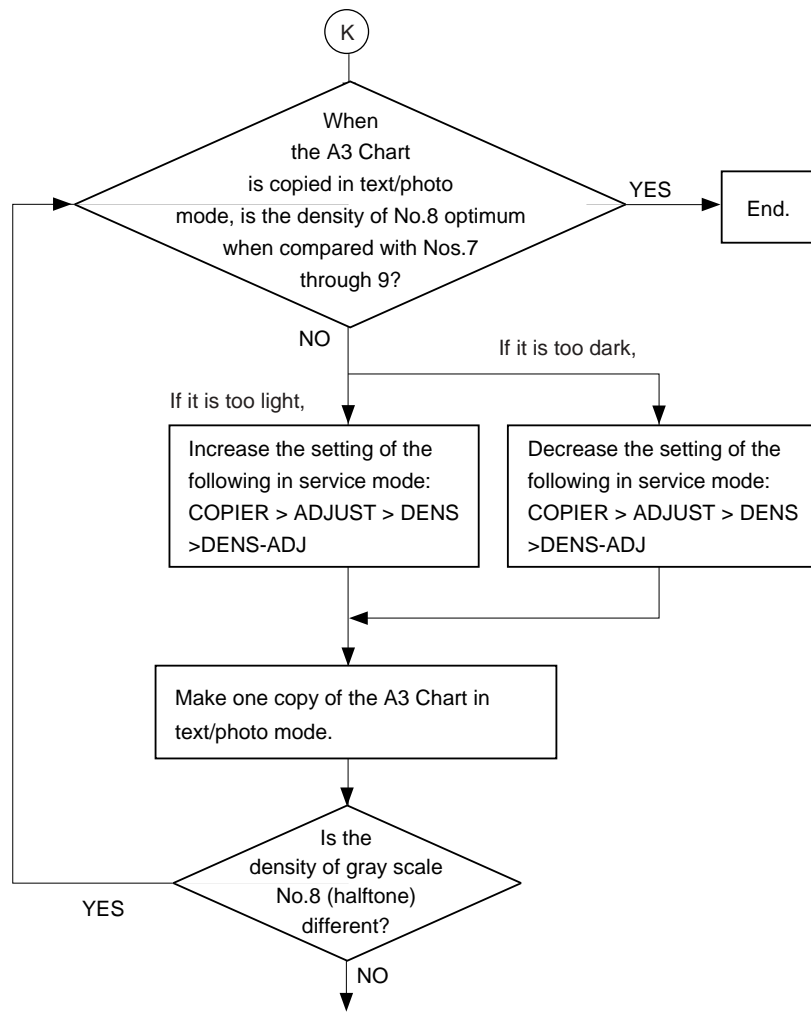

Go to "Checking the Solid Black Density" for the printer unit.

F-14-9

### 14.1.5 Checking the Potential System

iR5065 / iR 5055 / iR5075 / iR5075N / iR5065N / iR5055N

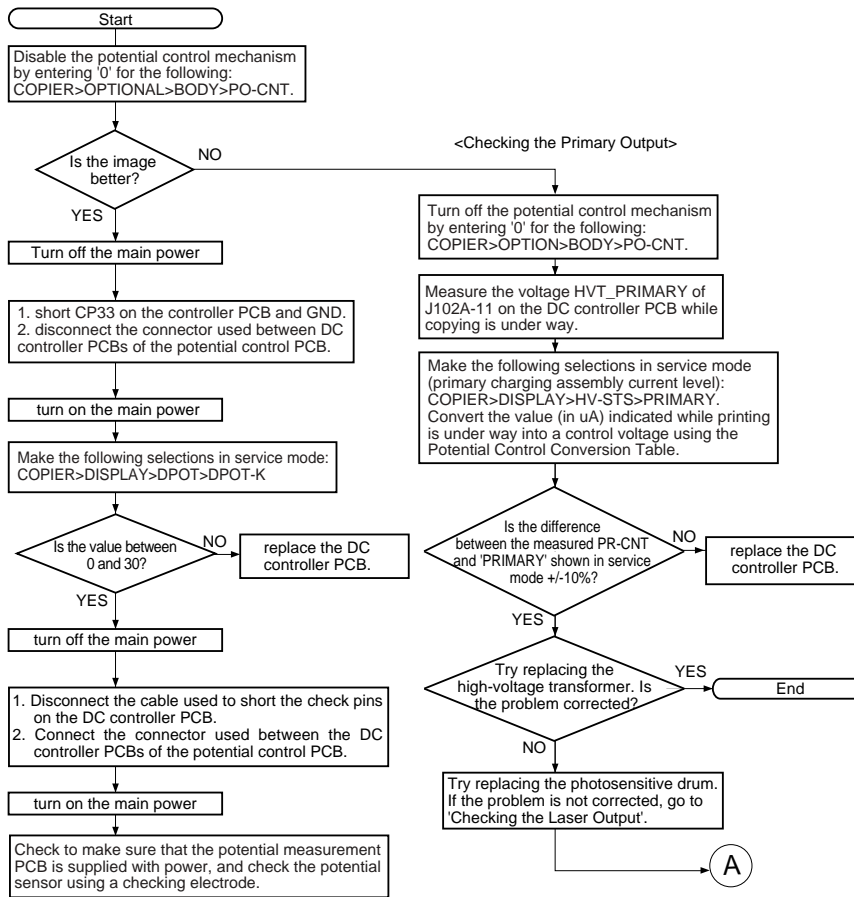

F-14-10

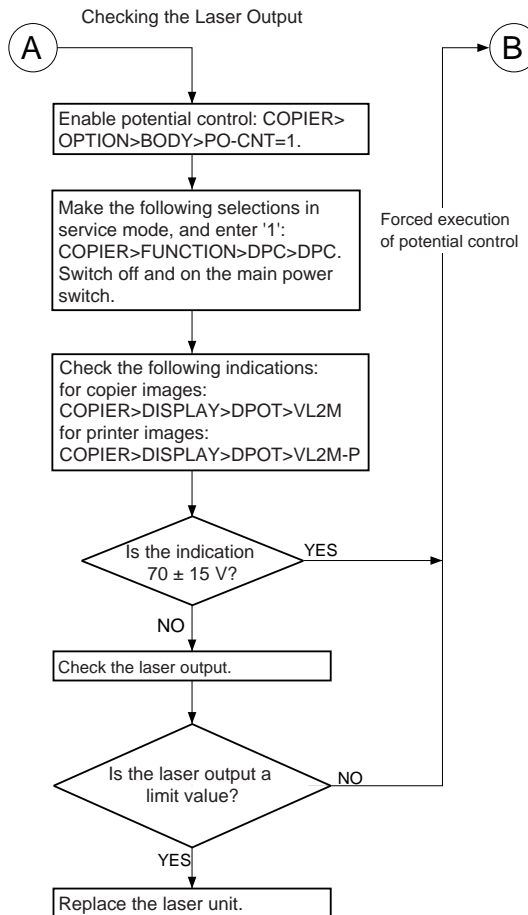

F-14-11

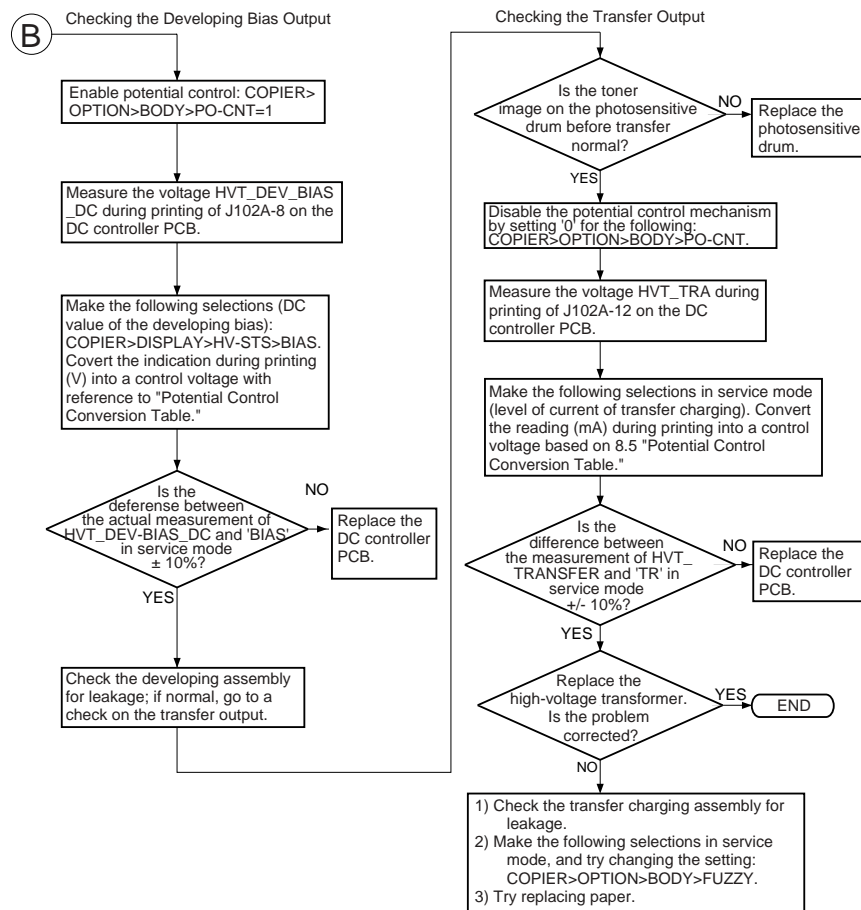

F-14-12

### 14.1.6 Checking the Surface Potential Control System

iR5065 / iR 5055 / iR5075 / iR5075N / iR5065N / iR5055N

#### 1. Outline

If an image fault occurs, it is necessary to find out whether the cause is in the static image formation block including the photosensitive drum and the potential control system or if it is caused at time of development or transfer.

An image fault may be isolated by finding out whether the surface potential is correct using service mode.

#### 2. Disabling the Auto Control Mechanisms

As a means of checking the potential control system, the auto control mechanism may be disabled (hereafter, non-auto control mode).

If the image fault in question is more or less corrected when the machine is in non-auto control mode, you can suspect the potential measurement unit and the DC controller PCB as the cause of the fault.

You can also take advantage of non-auto control mode as a tentative remedy when the auto control mechanism has a fault.



When the machine is in non-auto control mode, all settings used for corona current control, laser power control, and developing bias control will be automatically be set to default settings.

#### Using Non-Auto Control Mode

1) Make the following selections in service mode, enter '0', and press the OK key:

COPIER>OPTION>BODY>PO-CNT.

2) Press the Reset key twice.

#### 3. Making a Zero-Level check

A "zero-level check" is a check made to see if the control mechanism of the DC controller PCB is identifying a 0-V level without fail when the drum surface potential is 0 V.

A zero-level check may be made in either of 2 ways, and you can use it to decide whether the DC controller PCB and the potential measurement PCB is free of error:

Method 1: use it to find out if the level shift circuit on the DC controller PCB is free of a fault

Method 2: use it to find out if the potential control circuit is free of a fault

#### (1) Method 1

1) Turn off the main power switch.

2) Remove the upper rear cover.

3) Short GP33 on the DC controller PCB and GND using a cable equipped with an alligator clips or probes on both ends.



When shorting CP33 and GND, take full care to avoid contact between the clip/probe and the pattern of the PCB and other elements.

4) Remove the left cover (upper), delivery cover, and left cover (middle).

5) Remove the 5 screws [1], and detach the PCB cover [2].

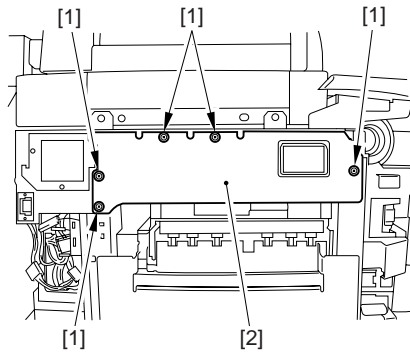

F-14-13

6) Disconnect the connector [1] connected to the DC controller PCB of the potential control PCB.

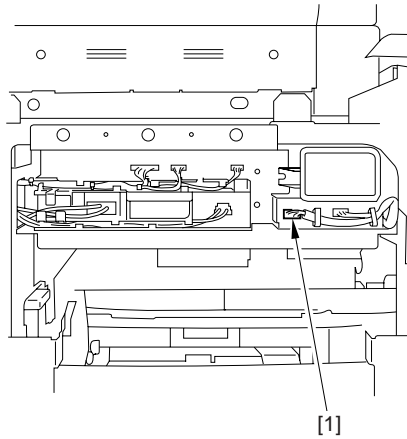

F-14-14

- 7) Close the front door, and turn on the main power switch.
- 8) Make the following selections in service mode:  
COPIER>DISPLAY>DPOT>DPOT-K; then, check to see that the indication during initial rotation is between 0 and 30. If not, suspect a fault in the DC controller PCB.
- 9) Turn off the main power switch.
- 10) Remove the jumper wire found on the DC control PCB.
- 11) Connect the connector of the potential control PCB.
- 12) Mount the PCB cover, left cover (middle), delivery cover, and left cover (upper); then, close the front cover.
- 13) Mount the upper rear cover.
- 14) Turn on the main power switch.

**(2) Method 2**

- 1) Disable the potential control mechanism so that the machine is in non-auto control mode.
- 2) Turn off the main power switch.
- 3) Remove the potential sensor from the machine.
- 4) Connect the connector of the potential sensor to the connector of the machine.
- 5) Fit the potential sensor checking electrode (FY9-3012) [2] to the potential sensor [1].

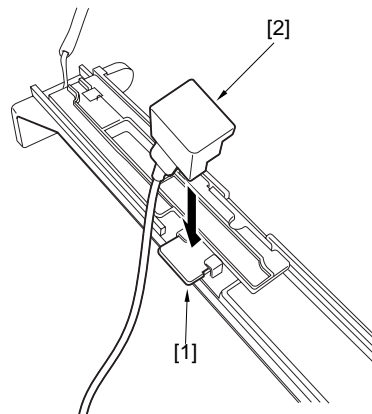

F-14-15



When fitting the checking electrode to the potential sensor, take full care so that the electrode will not come into contact with the potential sensor cover.

- 6) Connect the clip [1] of the checking electrode to the machine frame (GND).

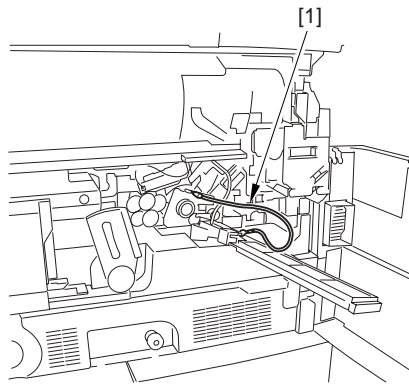

F-14-16



Be sure never to bring the clip [1] into contact with the sensor cover. Also, be sure to fit it sufficiently away from the sensor window.

- 7) Fit the door switch actuator into the door switch assembly.
- 8) Turn on the main power switch.



When you have turned on the main power switch, be sure never to touch the potential sensor.

- 9) Make the following selections in service mode:  
COPIER>DISPLAY>DPOT>DPOT-K. Then, check to see that the indication during initial rotation is between 0 and 30.

#### MEMO:

1. If the result of Method 1 is as indicated but that of Method 2 is not, suspect soiling of the sensor and a fault in the potential measurement unit.
2. If the results of both Methods 1 and 2 are as indicated, assume that the signal path and operation from the potential sensor unit to the microprocessor on the DC controller PCB are normal.

- 10) Turn off the main power switch.
- 11) Detach the potential sensor checking electrode.
- 12) Mount the potential sensor.
- 13) Turn on the main power switch.
- 14) Enable the potential control mechanism.

#### 14.1.7 Potential Control System Conversion Table

iR5065 / iR 5055 / iR5075 / iR5075N / iR5065N / iR5055N

T-14-1					
Control (V)	Primary (uA)	Developing bias (V)	Pre-transfer (uA)	Transfer (uA)	Separation (uA)
3.00	1,400	0	0	440	100
3.05	1,391	3	-2	437	96
3.10	1,382	7	-4	434	92
3.15	1,373	11	-6	431	88
3.20	1,365	15	-8	429	85
3.25	1,356	18	-10	426	81
3.30	1,347	22	-12	426	77
3.35	1,338	26	-14	420	73
3.40	1,330	30	-16	418	70
3.45	1,321	33	-18	415	66
3.50	1,312	37	-20	412	62
3.55	1,303	41	-22	409	58
3.60	1,295	45	-24	407	55

Control (V)	Primary (uA)	Developing bias (V)	Pre-transfer (uA)	Transfer (uA)	Separation (uA)
3.65	1,286	48	-26	404	51
3.70	1,277	52	-28	401	47
3.75	1,268	56	-30	398	43
3.80	1,260	60	-33	396	40
3.85	1,251	63	-35	393	36
3.90	1,242	67	-37	390	32
3.95	1,233	71	-39	387	28
4.00	1,225	75	-41	385	25
4.05	1,216	78	-43	382	21
4.10	1,207	82	-45	379	17
4.15	1,198	86	-47	376	13
4.20	1,190	90	-49	374	10
4.25	1,181	93	-51	371	6
4.30	1,172	97	-53	368	2
4.35	1,163	101	-55	365	-1
4.40	1,155	105	-57	363	-5
4.45	1,146	108	-59	360	-8
4.50	1,137	112	-61	357	-12
4.55	1,128	116	-63	354	-16
4.60	1,120	120	-66	352	-20
4.65	1,111	123	-68	349	-23
4.70	1,102	127	-70	346	-27
4.75	1,093	131	-72	343	-31
4.80	1,085	135	-74	341	-35
4.85	1,076	138	-76	338	-38
4.90	1,067	142	-78	335	-42
4.95	1,058	146	-80	332	-46
5.00	1,050	150	-82	330	-50
5.05	1,041	153	-84	327	-53
5.10	1,032	157	-86	324	-57
5.15	1,023	161	-88	321	-61
5.20	1,015	165	-90	319	-65
5.25	1,006	168	-92	316	-68



Control (V)	Primary (uA)	Developing bias (V)	Pre-transfer (uA)	Transfer (uA)	Separation (uA)
5.30	997	172	-94	313	-72
5.35	938	176	-96	310	-76
5.40	980	180	-99	308	-80
5.45	971	183	-101	305	-83
5.50	962	187	-103	302	-87
5.55	953	191	-105	299	-91
5.60	945	195	-107	297	-95
5.65	936	198	-109	294	-98
5.70	927	202	-111	291	-102
5.75	918	206	-113	288	-106
5.80	910	210	-115	286	-110
5.85	901	213	-117	283	-113
5.90	892	217	-119	280	-117
5.95	883	221	-121	277	-121
6.00	875	225	-123	275	-125
6.05	866	228	-125	272	-128
6.10	857	232	-127	269	-132
6.15	848	236	-129	266	-136
6.20	840	240	-132	264	-140
6.25	831	243	-134	261	-143
6.30	822	247	-136	258	-147
6.35	813	251	-138	255	-151
6.40	805	255	-140	253	-155
6.45	796	258	-142	250	-158
6.50	787	262	-144	247	-162
6.55	778	266	-146	244	-166
6.60	770	270	-148	242	-170
6.65	761	273	-150	239	-173
6.70	752	277	-152	236	-177
6.75	743	281	-154	233	-181
6.80	735	285	-156	231	-185
6.85	726	288	-158	228	-188
6.90	717	292	-160	225	-192

---

---

Control (V)	Primary (uA)	Developing bias (V)	Pre-transfer (uA)	Transfer (uA)	Separation (uA)
6.95	708	296	-162	222	-196
7.00	700	300	-165	220	-200
7.05	691	303	-167	217	-203
7.10	682	307	-169	214	-207
7.15	673	311	-171	211	-211
7.20	665	315	-173	209	-215
7.25	656	318	-175	204	-218
7.30	647	322	-177	203	-222
7.35	638	326	-179	200	-226
7.40	630	330	-181	198	-230
7.45	621	333	-183	195	-233
7.50	612	337	-185	192	-237
7.55	603	341	-187	189	-241
7.60	595	345	-189	187	-245
7.65	586	348	-191	184	-248
7.70	577	352	-193	181	-252
7.75	568	356	-195	178	-256
7.80	560	360	-198	176	-260
7.85	551	363	-200	173	-263
7.90	542	367	-202	170	-267
7.95	533	371	-204	167	-271
8.00	525	375	-206	165	-275
8.05	516	378	-208	162	-278
8.10	507	382	-210	159	-282
8.15	498	386	-212	156	-286
8.20	490	390	-214	154	-290
8.25	481	393	-216	151	-293
8.30	472	397	-218	148	-297
8.35	463	401	-220	145	-301
8.40	455	405	-222	143	-305
8.45	446	408	-224	140	-308
8.50	437	412	-226	137	-312
8.55	428	416	-228	134	-316

Control (V)	Primary (uA)	Developing bias (V)	Pre-transfer (uA)	Transfer (uA)	Separation (uA)
8.60	420	420	-231	132	-320
8.65	411	423	-233	129	-323
8.70	402	427	-235	126	-327
8.75	393	431	-237	123	-331
8.80	385	435	-239	121	-335
8.85	376	438	-241	118	-338
8.90	367	442	-243	115	-342
8.95	358	446	-245	112	-346
9.00	350	450	-247	110	-350
9.05	341	453	-249	107	-353
9.10	332	457	-251	104	-357
9.15	323	461	-253	101	-361
9.20	315	465	-255	99	-365
9.25	306	468	-257	96	-368
9.30	297	472	-259	93	-372
9.35	288	476	-261	90	-376
9.40	280	480	-264	88	-380
9.45	271	483	-266	85	-383
9.50	262	487	-268	82	-387
9.55	253	491	-270	79	-391
9.60	245	495	-272	77	-395
9.65	236	498	-274	74	-398
9.70	227	502	-276	71	-402
9.75	218	506	-278	68	-406
9.80	210	510	-280	66	-410
9.85	201	513	-282	63	-413
9.90	192	517	-284	60	-417
9.95	183	521	-286	57	-421
10.00	175	525	-288	55	-425
10.05	166	528	-290	52	-428
10.10	157	532	-292	49	-432
10.15	148	536	-294	46	-436
10.20	140	540	-297	44	-440

Control (V)	Primary (uA)	Developing bias (V)	Pre-transfer (uA)	Transfer (uA)	Separation (uA)
10.25	131	543	-299	41	-443
10.30	122	547	-301	38	-447
10.35	113	551	-303	35	-451
10.40	105	555	-305	33	-455
10.45	96	558	-307	30	-458
10.50	87	562	-309	27	-462
10.55	78	566	-311	24	-466
10.60	70	570	-313	22	-470
10.65	61	573	-315	19	-473
10.70	52	577	-317	16	-477
10.75	43	581	-319	13	-481
10.80	35	585	-321	11	-485
10.85	26	588	-323	8	-488
10.90	17	592	-325	5	-492
10.95	8	596	-327	2	-496
11.00	0	600	-330	0	-500

### 14.1.8 Emergency Measures for a Fault in the Potential Sensor

iR5065 / iR 5055 / iR5075 / iR5075N / iR5065N / iR5055N

If the potential sensor goes out of order and, as a result, a transfer separation fault occurs, use the following service mode item to avoid problems; be sure, however, that this is merely a tentative remedy to be used until the potential sensor is replaced:

1. COPIER>OPTION>TEMPO>F-POT-SW (Category 2)

Set '1' if a transfer separation fault occurs when the potential sensor has gone out of order.

2. COPIER>OPTION>TEMPO>F-POT-D (Category 2)

This is enabled when '1' is set for the foregoing service mode item.

0: if the user primarily uses originals with a low image ratio (text original). (default)

1: if the user primarily uses originals with a high image ratio (photo originals)

2: if re-transfer (drop-out about 50 mm of leading edge) occurs.

## 14.2 Image Adjustments

### 14.2.1 Standards of Image Position

iR5065 / iR 5055 / iR5075 / iR5075N / iR5065N / iR5055N

The image margin/non-image width of a print made in direct must be as follows:  
 image Leading Edge Margin



F-14-17

Left/Right Image Margin

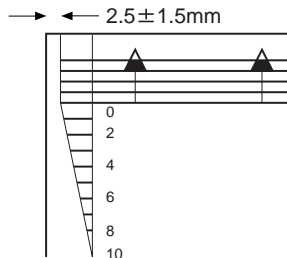

F-14-18

Leading Edge Non-Image Width



F-14-19

Left/Right Non-Image Width

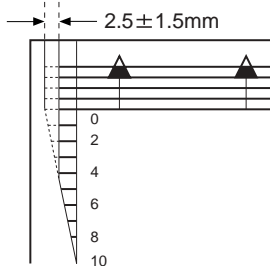

F-14-20

### 14.2.2 Checking the Image Position

iR5065 / iR 5055 / iR5075 / iR5075N / iR5065N / iR5055N

Make prints using the following as the source of paper (10 prints each), and check to see that the image margin and the non-image width are as indicated:

- Each cassette
- Front deck (left, right)
- Manual feed tray
- Duplex feeding unit
- Side paper deck

If not as indicated, adjust the image position in the following order:

1. Adjusting the left/right image margin (registration)
2. Adjusting the image leading edge margin (registration)
3. Adjusting the left/right non-image width (CCD read start position)
4. Leading edge non-image width (scanner image leading edge position)

### 14.2.3 Adjusting Side Registration

iR5065 / iR 5055 / iR5075 / iR5075N / iR5065N / iR5055N

<Cassette 3/4>

- 1) Press the release button to draw out the cassette 3/4.
- 2) Loosen the 2 fixing screws [1] on both sides of the cassette.
- 3) Move the cassette body frontward or backward to adjust.  
 Backward: The side registration value (left margin) is decreased.  
 Forward: The side registration value (left margin) is increased.

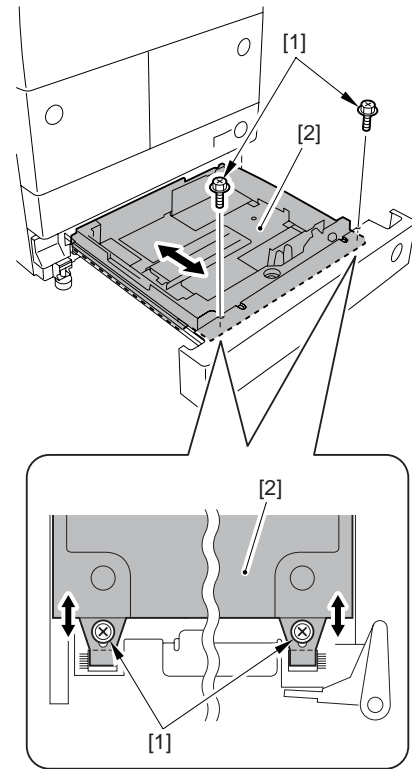

F-14-21

- 4) Make sure that the side registration values (left margins) of a copy made from the cassette 3/4 are  $L1 = 2.5 \pm 1.5\text{mm}$  respectively.

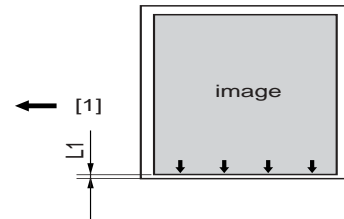

F-14-22

- [1] Paper feed direction
- 5) Tighten back the 2 fixing screws [1] after the adjustment.

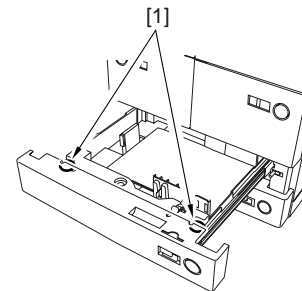

F-14-23

- 6) Put back the cassette 3/4 to the machine.
- 7) Perform the following service mode after the adjustment.  
 Cassette 3  
 COPIER > FUNCTION > CST > C3-STMTR/A4R  
 Use it to register the paper width basic value of the cassette 3.  
 1) Put STMTR/A4R paper in the cassette3, and adjust the slide guide plate to the width.  
 2) Select C3-STMTR/A4R to highlight, and press the OK key so that the machine executes auto adjustment and register the value.  
 Cassette 4  
 COPIER > FUNCTION > CST > C4-STMTR/A4R  
 This operation is similar to cassette 3.

<Front Deck Left/Right>

- 1) Press the release button to draw out the front deck left/right.
- 2) Loosen the 2 screws [2] and 2 fixing screws [3] of the deck front cover [1].

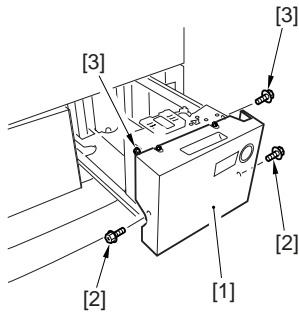

F-14-24

- 3) Move the cassette plate (front) [1] forward or backward to adjust.  
 Backward: The side registration value (left margin) is decreased.  
 Forward: The side registration value (left margin) is increased.

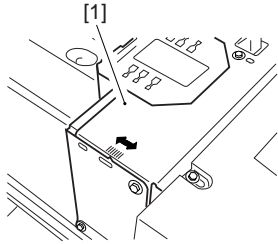

F-14-25

- 4) Make sure that the side registration values (left and right margins) of a copy made from the front deck left/right are  $L1 = 2.5 \pm 1.5$ mm respectively.

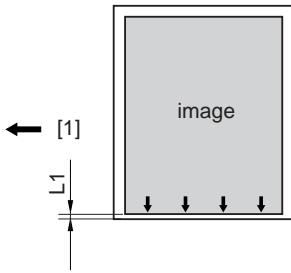

F-14-26

[1] Paper feed direction

- 5) Tighten the 2 screws [2] and 2 fixing screws [3] of the deck front cover [1].

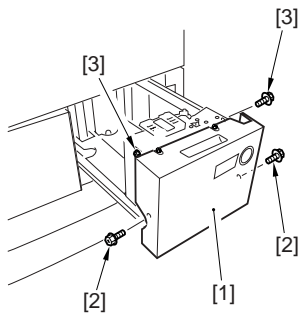

F-14-27

- 6) Put back the front deck left/right to the machine.

**<Manual Feed Tray>**

- 1) Move the side plates [1] to the center. Loosen the 2 mounting screws [2] of the manual feed tray, and adjust the position of the manual feed tray.

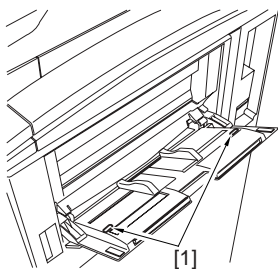

F-14-28

**<Duplexing Feeder Unit>**

- 1) Select the following service mode COPIER > ADJUST > FEED-ADJ > ADJ-REFE, and make an adjustment so that margin on the 2nd side image will be within specs.

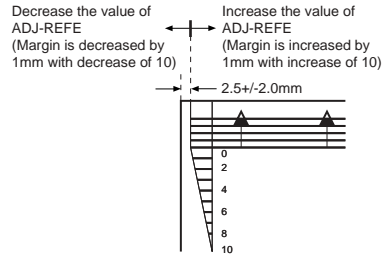

F-14-29

**14.2.4 Adjusting the Image Leading Edge Margin**

iR5065 / iR 5055 / iR5075 / iR5075N / iR5065N / iR5055N

- 1) Adjust the image margin in service mode so that it is as indicated: COPIER > ADJUST > FEED-ADJ > REGIST.

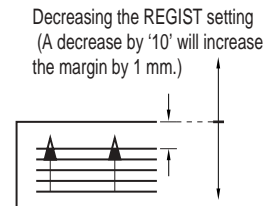

F-14-30

**14.2.5 Adjusting the Left/Right Non-Image Width**

iR5065 / iR 5055 / iR5075 / iR5075N / iR5065N / iR5055N

- 1) Adjust the non-image width in service mode so that it is as indicated: COPIER > ADJUST > ADJ-XY > ADJ-Y.

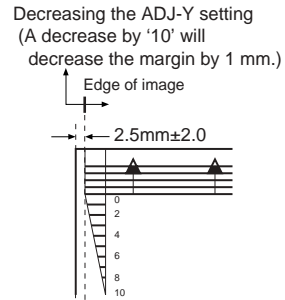

F-14-31

Increasing the ADJ-Y setting (An increase by '10' will increase the non-image width by 1 mm.)

**14.2.6 Adjusting the Leading Edge Non-Image Width**

iR5065 / iR 5055 / iR5075 / iR5075N / iR5065N / iR5055N

- 1) Adjust the non-image width in service mode so that it is as indicated: COPIER > ADJUST > ADJ-XY > ADJ-X.

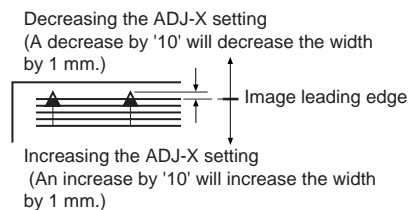

F-14-32

## 14.3 Scanning System

### 14.3.1 After Replacing the Reader Controller PCB

iR5065 / iR 5055 / iR5075 / iR5075N / iR5065N / iR5055N



Be sure to generate the latest P-PRINT printout before replacing the reader controller PCB.

- If you are initializing the RAM on the reader controller without replacing the PCB

Using the SST, upload the backup data of R-CON; initialize the RAM, and then download the data, thus eliminating the need for the following.

- 1) Using the SST, download the latest system software (R-CON).
- 2) Make the following selections in the service mode: COPIER > FUNCTION > CLEAR > R-CON. Then, press the OK key to execute RAM initialization. Thereafter, turn off and then back on the main power.
- 3) Enter the appropriate settings for the following items in the service mode:
  - a. setting indicated on the service label (found behind the reader unit front cover)
    - a-1. image read start position adjustment (X direction; in fixed reading mode)  
COPIER>ADJUST>ADJ-XY>ADJ-X
    - a-2. image read start position adjustment (Y direction; in fixed reading mode)  
COPIER>ADJUST>ADJ-XY>ADJ-Y
    - a-3. shading position adjustment (in fixed reading mode)  
COPIER>ADJUST>ADJ-XY>ADJ-S
    - a-4. feeder mode main scanning position adjustment  
COPIER>ADJUST>ADJ-XY>ADJ-Y-DF
    - a-5. ADF stream reading CCD reading position  
COPIER>ADJUST>ADJ-XY>STRD-POS
    - a-6. density manipulating value adjustment  
COPIER>ADJUST>CCD>DFCH-G2  
COPIER>ADJUST>CCD>DFCH-G10  
(After inputs it, execute COPIER>FUNCTION>DF-LNR)



The machine retains ADF-related service data in the RAM of its reader controller.

ADF adjustment is necessary whenever you have replaced the reader controller or initialized the RAM.

- b. original stop position adjustment (X direction) (stream reading)  
FEEDER>ADJUST>DOCST
  - c. original feed speed (magnification) adjustment  
FEEDER>ADJUST>LA-SPEED
- 4) Make adjustments using the following service mode items:
    - a. ADF sensor sensitivity adjustment  
FEEDER>FUNCTION>SENS-INT
    - b. tray width adjustment  
FEEDER>FUNCTION>TRY-A4  
FEEDER>FUNCTION>TRY-A5R  
FEEDER>FUNCTION>TRY-LTR  
FEEDER>FUNCTION>TRY-LTRR
    - c. white plate data adjustment  
COPIER>FUNCTION>CCD>CCD-ADJ
    - d. ADF white level adjustment  
COPIER>FUNCTION>CCD>DF-WLVL1  
COPIER>FUNCTION>CCD>DF-WLVL2



Be sure to perform white plate data adjustment before performing ADF white level adjustment.

After having made the foregoing adjustments, put the P-PRINT printout in the service book case, replacing the previous P-PRINT printout.

### 14.3.2 When Replacing the CCD Unit

iR5065 / iR 5055 / iR5075 / iR5075N / iR5065N / iR5055N

Perform the following steps after replacing the CCD unit.

- 1) Enter the correction values to be described on the label included in the CCD unit (the 2 following items) in the service mode.
  - COPIER > ADJUST > CCD > DFCH2G2
  - COPIER > ADJUST > CCD > DFCH2G10
- 2) Transcribe the above correction values to the service label at the back of the front cover of the host machine.
- 3) Execute the following in the service mode.
  - 3-1) White plate data adjustment (COPIER > FUNCTION > CCD > CCD-ADJ)

3-2) ADF white level adjustment (COPIER > FUNCTION > CCD > DF-WLVL1/2)



Be sure to perform white plate data adjustment before performing ADF white level plate.

### 14.3.3 Adjusting the Position of the No. 1/No. 2 Mirror Base

iR5065 / iR 5055 / iR5075 / iR5075N / iR5065N / iR5055N

- 1) Arrange the mirror positioning tool (FY9-3009-040) so that it is ready for use in the machine (by changing the pin position; REAR).

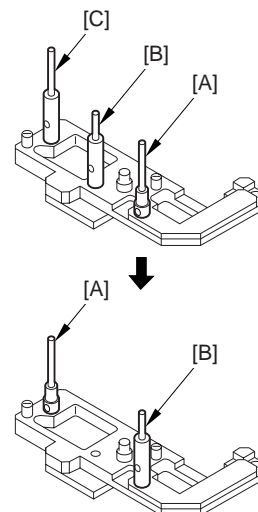

F-14-33

- 2) Arrange the mirror positioning tool so that it is ready for use in the machine (by changing the pin position; FRONT).

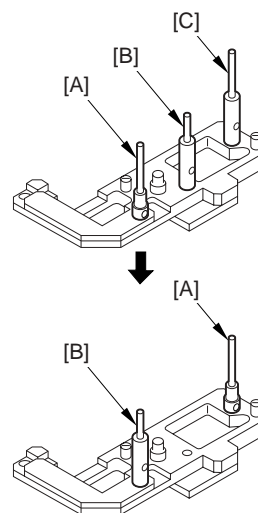

F-14-34

- 3) Fit the pins of the mirror positioning tool (front [2]; rear [3]) into the appropriate holes [1] of the No. 1/No. 2 mirror base.

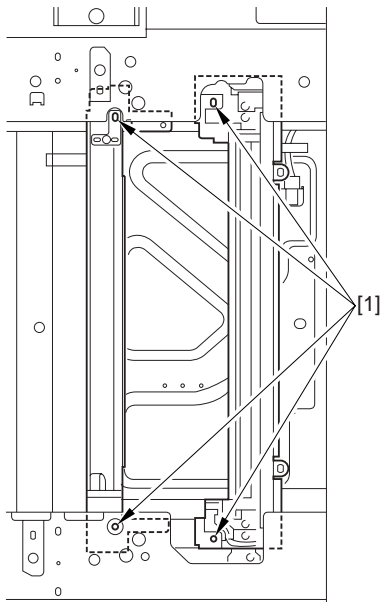

F-14-35

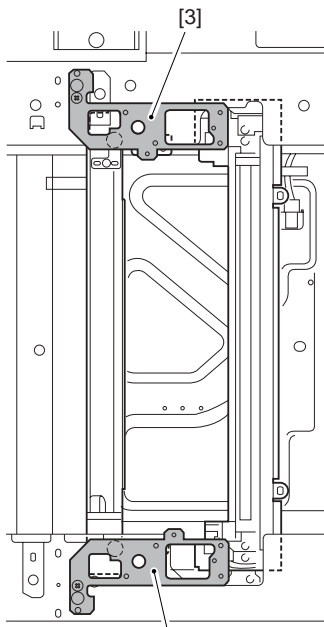

F-14-36

- 4) Secure the end of the cable that has temporarily been fixed in place on the hook of the reader unit frame.
- 5) Fully tighten the screws on the cable fixing plate both at the front and the rear.
- 6) Detach the mirror positioning tool (FRONT, REAR).
- 7) Put the detached parts back on by reversing the foregoing steps.

#### 14.3.4 When Replacing the Copyboard Glass

iR5065 / iR 5055 / iR5075 / iR5075N / iR5065N / iR5055N

Execute the following in the service mode:

- 1) White plate data adjustment (COPIER > FUNCTION > CCD > CCD-ADJ)
- 2) ADF white level adjustment (COPIER > FUNCTION > CCD > DF-WLVL1/2)



Be sure to perform white plate data adjustment before performing ADF white level adjustment.

#### 14.3.5 When Replacing the Reading Glass

iR5065 / iR 5055 / iR5075 / iR5075N / iR5065N / iR5055N

Execute the following in service mode:

- 1) ADF white level adjustment (COPIER>FUNCTION>CCD>DF-WLVL1/2).

#### 14.3.6 When Replacing the Scanning Lamp

iR5065 / iR 5055 / iR5075 / iR5075N / iR5065N / iR5055N

Execute the following in the service mode:

- 1) White plate data adjustment (COPIER > FUNCTION > CCD > CCD-ADJ)
- 2) ADF white level adjustment (COPIER > FUNCTION > CCD > DF-WLVL1/2)



Be sure to perform white plate data adjustment before performing ADF white level adjustment.

#### 14.3.7 After Replacing the Inverter PCB

iR5065 / iR 5055 / iR5075 / iR5075N / iR5065N / iR5055N

Execute the following in the service mode:

- 1) White plate data adjustment (COPIER > FUNCTION > CCD > CCD-ADJ).
- 2) ADF white level adjustment (COPIER > FUNCTION > CCD > DF-WLVL1/2).



Be sure to perform white plate data adjustment before performing ADF white level plate.

### 14.4 Laser Exposure System

#### 14.4.1 When Replacing the Scanner Unit

iR5065 / iR 5055 / iR5075 / iR5075N / iR5065N / iR5055N

If the temperature of the fixing assembly is 150 deg C or higher when the main power switch is turned on, the machine will not execute potential control. If such is the case after replacing the scanner unit, manually execute potential control in service mode as follows:

- 1) Make the following selections in service mode: COPIER>FUNCTION>DPC>DPC; then, enter '1', and press [OK].
- 2) Turn off and then back on the main power switch.

### 14.5 Image Formation System

#### 14.5.1 Outline

iR5065 / iR 5055 / iR5075 / iR5075N / iR5065N / iR5055N

The photosensitive drum is surrounded by 3 charging wires; the primary charging wire, the pre-transfer charging wire, and the transfer/separation charging wire.

These charging wires are newly adopted brown wires (0.06 mm in diameter). Do not use a gold-plated wire that has been used in the past; otherwise, image fault may occur.

Further, be sure to use a strengthened polishing pad (in a blue holder) as the cleaning pad for the primary charging assembly and the transfer charging assembly.

#### 14.5.2 Routing Charging Wire

iR5065 / iR 5055 / iR5075 / iR5075N / iR5065N / iR5055N

All charging wires (except the grid wire) are routed more or less in the same way; the following cites the primary charging assembly.

- 1) Remove the shield plates (left, right) of the charging assembly. To prevent deformation (deflection) in the primary charging assembly, be sure to work separately for the left shielding plate and the right shielding plate (do not loosen the screws [1] of both shielding plates at the same time.)
- 2) Remove the wire cleaner.

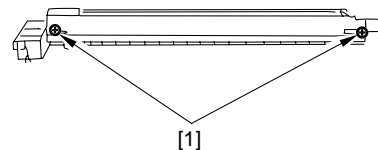

F-14-37



For other charging assemblies, remove the 2 covers.



- 3) Free a length of about 5 cm of the charging wire (0.06 mm in diameter) from the charging wire reel, and form a loop at its end with a diameter of about 2 mm.

**MEMO:**

To form a loop, wind the charging wire around a hex key once, and turn the hex key 3 to 4 times; then, twist the charging wire.

- 4) Cut the end (excess) of the twisted wire.  
5) Hook the loop on the stud.

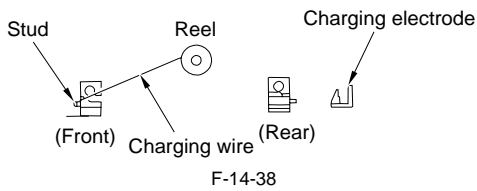

F-14-38

- 6) At the rear, hook the charging wire on the charging wire positioning plate; then, hook the charging wire tension spring on the charging wire where indicated to the following figure.

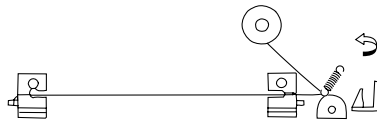

F-14-39

- 7) Cut off the excess of the charging wire with nippers.  
8) Pick the end of the charging wire tension spring with tweezers, and hook it on the charging power supply electrode. In the case of the pre-transfer charging assembly, hook the spring on the pin at the front.

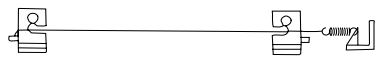

F-14-40

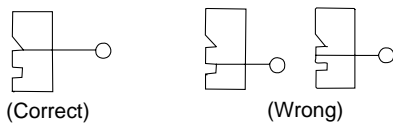

(Correct)

(Wrong)

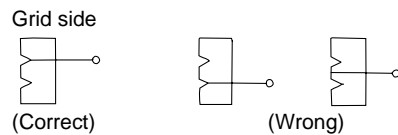

(Correct)

(Wrong)

F-14-41



Make sure the followings:

- The charging wire must not be bent or twisted.
- The charging wire must be fitted in the V-groove of the charging wire positioning plate.

- 9) Attach a cushion in front of the charging wire (except the primary charging assembly).  
10) Attach the shield plates (left, right).



For other charging assemblies, attach the 2 covers.

- 11) Attach the wire cleaner. At this time, make sure the orientation of the wire cleaner.  
12) Wipe the charging wire with lint-free paper moistened with alcohol solutions.

### 14.5.3 Routing Grid for Primary Charging Assembly

iR5065 / iR 5055 / iR5075 / iR5075N / iR5065N / iR5055N

- 1) Loosen the 2 screws used to secure the left and right shielding plates in place.  
2) Loosen the 3 screws used to secure the motor unit at the front in place.

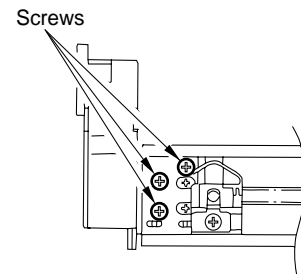

F-14-42

- 3) Loosen the screw, and move it in the direction of the arrow indicated below; then, temporarily tighten it in place.  
4) Free a length of about 5 cm of the charging wire (0.1 mm in diameter) from the charging wire reel, and form a loop at its end with a diameter of about 2 mm.

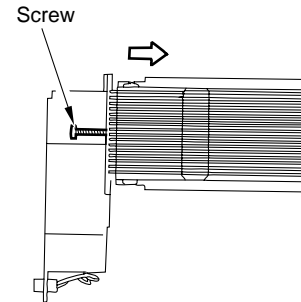

F-14-43

**MEMO:**

To form a loop, wind the charging wire around a hex key once, and turn the hex key 3 to 4 times; then, twist the charging wire.

- 5) Cut the twisted charging wire (excess) with nippers.  
6) Hook the loop on the stud.  
7) After routing the wire for 31 runs, lead it through the section B, and give it a half turn; then, put it between the washer and the monitor unit, and wind it once around the screw (clockwise), and secure it in place with the screw.

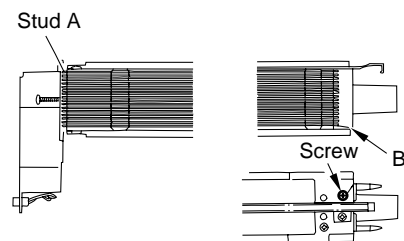

F-14-44

- 8) Cut the excess of the charging wire with nippers.  
9) Tighten the screw loosened in the step 3. Keep tightening until the tension of the grid wire is even. Be sure to pay attention to avoid deformation (deflection) of the charging assembly (as by tightening the screw at the front of the left/right shielding plate early).  
10) Tighten the screws loosened in the step 1 and 2.  
11) Wipe the grid wire with lint-free paper moistened with alcohol solutions.



Make sure the followings:

- The grid wire must not be bent or twisted.
- The wires are laid at equal intervals. (The grid wire must be fitted in the groove of the block.)

### 14.5.4 Adjusting Height of Charging Wire

iR5065 / iR 5055 / iR5075 / iR5075N / iR5065N / iR5055N

[1] Primary charging wire

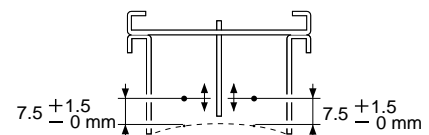

F-14-45

Height of the charging wire

<Tolerance> +/- 1 mm

[2] Pre-transfer charging wire

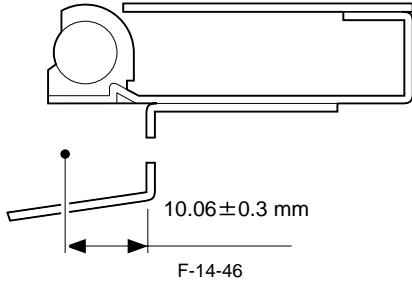

Height of the charging wire  
<Tolerance> No height adjusting mechanism

[3] Transfer charging wire

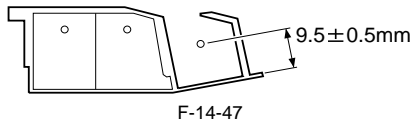

Height of the charging wire  
<Tolerance> +/- 2 mm

[4] Separation charging wire

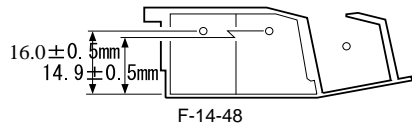

Height of the charging wire  
<Tolerance> +/- 2 mm

**MEMO:**

The height (position) of the primary charging wire and the transfer charging wire can be adjusted by turning the screw at the back of the charging assembly. A single turn changes the position of the charging wire by about 0.7 mm.

**14.5.5 Mounting Cleaning Blade**

iR5065 / iR 5055 / iR5075 / iR5075N / iR5065N / iR5055N

When mounting the cleaning blade, be sure that the side with the marking [1] will be the face.

1) Push in the cleaning blade [2] until it butts slightly against the rear.

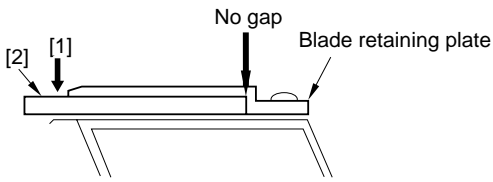

2) Tighten the 5 screws [3] lightly, and stop to turn them when resistance is felt.

3) Turn the screws tightened lightly in the step 2 about 20 to 30 degrees in the order indicated below, and tighten them fully.

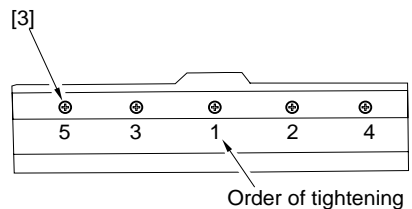

F-14-50



After mounting the cleaning blade, check that the edge of the blade is not extremely bent. Further, be sure to clean the groove in the blade support plate before mounting the blade, as toner or the like in the groove can be the cause the bending of the blade. AB

**14.5.6 Removing Side Seal**

iR5065 / iR 5055 / iR5075 / iR5075N / iR5065N / iR5055N

1) Remove the old side seal.  
2) Mount the new side seal [1] to the cleaner housing where indicated (both ends).

At this time, be sure that the edge of the side seal is positioned as follow:  
- When replacing the side seal [1] at the front, push the magnet roller [2] toward the rear, and then, make sure that the inner end of the side seal is within the area [3] of the washer.  
- When replacing the side seal [1] at the rear, push the magnet roller [2] toward the front, and then, make sure that the inner end of the side seal is within the area [3] of the washer.

3) The bottom end of each side seal [1] must be 0 to 0.5 mm from the corner of the cleaner housing; i.e., point of reference [4].

4) Attach the side seal [1] at the front and the rear to the cleaner housing while making sure its position is as indicated.

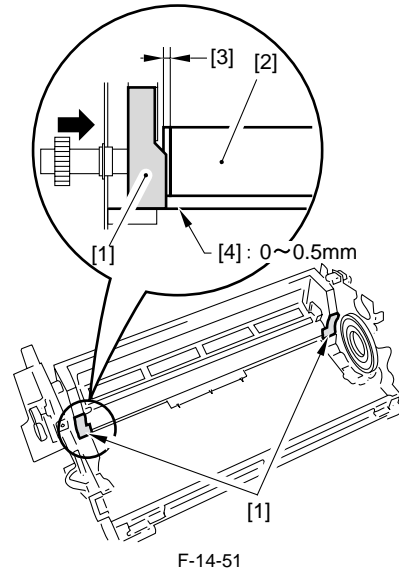

**14.6 Fixing System**

**14.6.1 Applying Grease After Replacing the Fixing Roller**

iR5065 / iR 5055 / iR5075 / iR5075N / iR5065N / iR5055N

- About 20mg of grease (Molykote HP-300; CK-8012) should be applied to the inner [1] and the outer surfaces [2] of the bushing until the white coat covering is formed uniformly. If this undone, the noise (squeaking) may occur.

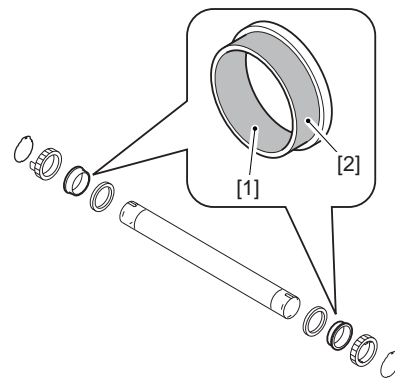

F-14-52

- Applied grease may be transferred from the bushing to the fixing roller ends [1] when mounting; be sure to wipe it off when this happens.

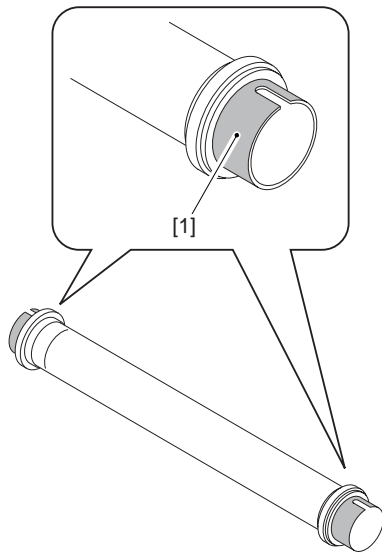

F-14-53

### 14.6.2 Adjusting the Nip Width

iR5065 / iR 5055 / iR5075 / iR5075N / iR5065N / iR5055N

The nip width adjustment is not necessary.

### 14.6.3 Adjusting the Fixing Web Solenoid (SL9)

iR5065 / iR 5055 / iR5075 / iR5075N / iR5065N / iR5055N

#### a. For New Fixing Webs

Adjust the solenoid position with the screw [2] so that the drive lever [1] can shift up to 8.6mm.

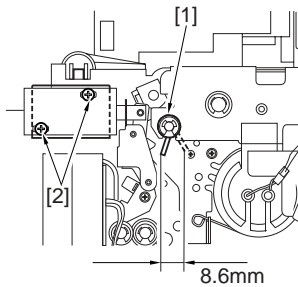

F-14-54

#### b. For Used Fixing Webs

Before removing the solenoid, check the position (A) of the drive lever [1] when the solenoid is turned on. After replacing the solenoid, adjust the drive lever [1] position with the screw [2] so that it positions as it did before replacement.

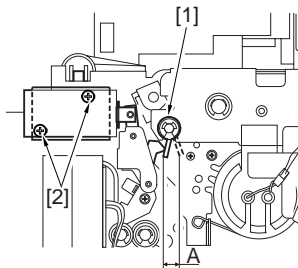

F-14-55

### 14.6.4 After Replacing the Fixing Web

iR5065 / iR 5055 / iR5075 / iR5075N / iR5065N / iR5055N

After replacing the fixing web, be sure to reset the counter reading to '0' by using the following service mode items.

**COPIER> COUNTER> MISC> FIX-WEB**  
**COPIER> COUNTER> DRBL-1> FX-WEB**

### 14.6.5 Adjusting the Fixing Inlet Guide Solenoid (SL1)

iR5065 / iR 5055 / iR5075 / iR5075N / iR5065N / iR5055N

Adjust the position of the fixing inlet guide solenoid with the screw [1] so that the guide positions as shown in the figure below when the solenoid is turned on.

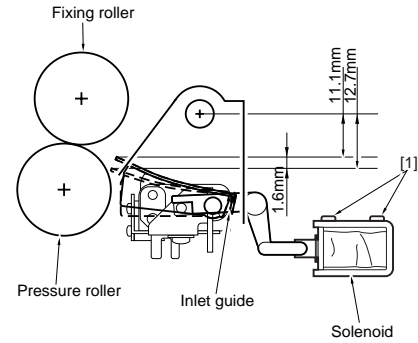

F-14-56

### 14.6.6 Adjusting the Position of the Fixing Inlet Guide

iR5065 / iR 5055 / iR5075 / iR5075N / iR5065N / iR5055N

Adjust the position of the solenoid using the two screws [1] so that the fixing inlet guide will be positioned as indicated when the solenoid turns on.

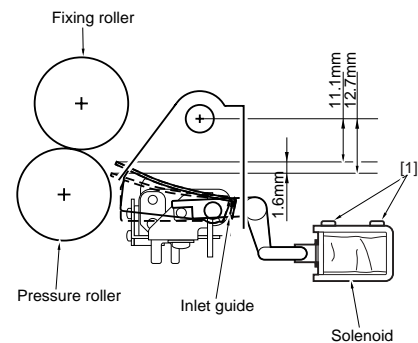

F-14-57

<Points to Note When Making Adjustments in th Field>

- The inlet guide is in low position when the solenoid (SL1) goes on.
- The height of the inlet guide must be such that the difference between the front and the rear must be 0.2 mm or less.
- As necessary, adjust the height of the inlet guide by loosening the fixing screw on the height adjusting support plate.

## 14.7 Electrical Components

### 14.7.1 When Replacing DC Controller PCB

iR5065 / iR 5055 / iR5075 / iR5075N / iR5065N / iR5055N

Be sure to perform the followings when replacing the DC controller PCB.

- 1) Enter the latest values for the service mode indicated on the label [1] on the back of the front cover with the service mode.
- 2) Enter the values indicated on the label [1] of the new PCB using the following service mode items:
  - COPIER> ADJUST> HV-TR> D-PRE-TR
  - COPIER> ADJUST> HV-TR> D-HV-TR
  - COPIER> ADJUST> HV-SP> D-HV-SP
  - COPIER> ADJUST> DEVELOP> D-HV-DE
- 3) Move the J303 shorting connector [2] on the PCB from the existing to the new PCB.



Make sure to connect the shorting connector. Otherwise, E004 occurs.

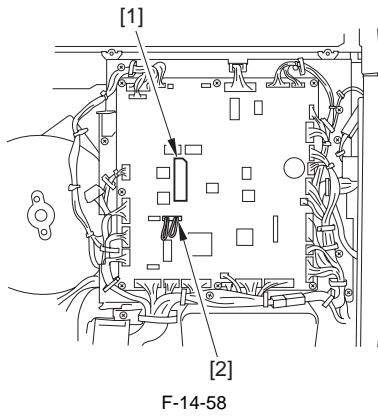

### 14.7.2 When Replacing HVT PCB

iR5065 / iR 5055 / iR5075 / iR5075N / iR5065N / iR5055N

Enter the values indicated on the label of the HVT PCB using the following service mode items:

```
COPIER>ADJUST>HV-TR>H-PRE-TR
COPIER>ADJUST>HV-TR>HVT-TR
COPIER>ADJUST>HV-SP>HVT-SP
COPIER>ADJUST>DEVELOP>HVT-DE
```

### 14.7.3 After Replacing the HDD

iR5065 / iR 5055 / iR5075 / iR5075N / iR5065N / iR5055N

- Formatting the HDD

Start up the machine in the safe mode (i.e., while holding down the 2 and 8 keys, turn on the main power).

Using the HD format function of the SST, format all partitions (BOOTDEV/PDLDEV/FSTDEV/FSTCDEV/TMP\_GEN/TMP\_FAX/TMP\_PSS/IMG\_MNG/APL\_MEAP/APL\_GEN/APL\_SEND). (For details, see the descriptions given for upgrading.)

- Downloading the system software

Using the SST, download the following: System, Language, RUI, MEAP-CONT (Meap content), SDICT (OCR dictionary), KEY (key/certificate for encrypted communication), TTS (audio dictionary).

### 14.7.4 When Replacing the Main Controller PCB

iR5065 / iR 5055 / iR5075 / iR5075N / iR5065N / iR5055N

Upload each setting/registration data stored in SRAM of the main controller PCB onto the PC by using SST. See the chapter 'Version Upgrading' for its operation procedure.

If you are replacing the main controller PCB, be sure to transfer the following components from the old to new PCB.

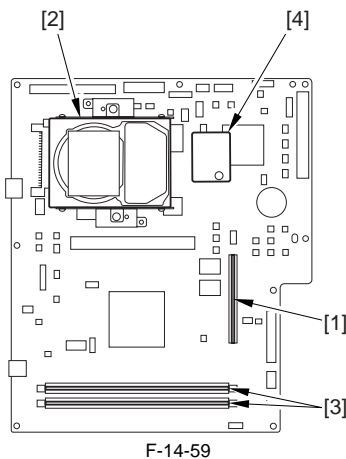

- [1] Boot ROM
- [2] Hard disk
- [3] Image memory (SDRAM)
- [4] Counter memory PCB

## 14.8 Pickup/Feeding System

### 14.8.1 Points to Note When Mounting the Pickup Roller

iR5065 / iR 5055 / iR5075 / iR5075N / iR5065N / iR5055N

⚠ The direction of the mounting pickup roller  
The pickup roller may be mounted by reversing the steps used to remove it; however, be sure to keep the following in the mind.

- The roller used at the front and the rear of the machine is not compatible.
- When mounting the pickup roller used at the front of the machine [1], make sure the round mark [2] and the punch mark [3] found on the side of the roller are toward the front of the machine.

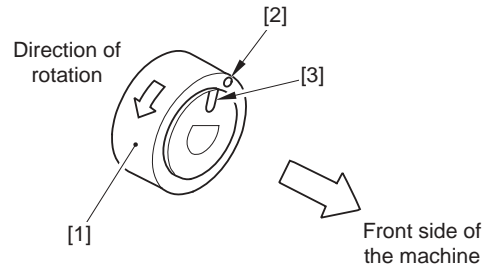

- When mounting the pickup roller used at the rear of the machine [1], make sure the punch mark [2] is at the rear of the machine.

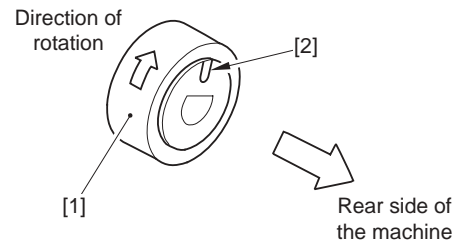

### 14.8.2 Points to Note When Mounting the Separation Roller

iR5065 / iR 5055 / iR5075 / iR5075N / iR5065N / iR5055N

When replacing the separation roller, be sure it is oriented as follows.



Mounting the separation roller in a wrong orientation may lead to interference against the crimping washer. Make sure it is mounted in a correct orientation.

Cassette 1/2, Right deck pickup assembly

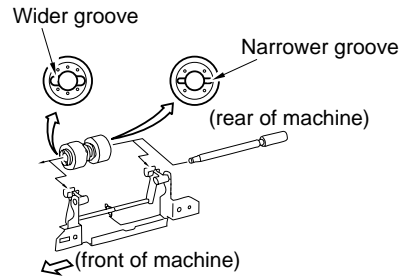

Left deck pickup assembly

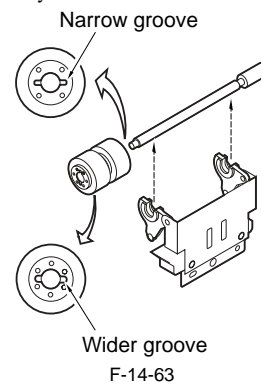

### 14.8.3 The Points to Mount the Feeding Roller

iR5065 / iR 5055 / iR5075 / iR5075N / iR5065N / iR5055N

When mounting the feeding roller [1] to the cassette pickup assembly, make

sure the belt pulley [2] is at the front of the machine.



Check to make sure the protrusion in the roller plate and roller are engaged securely.

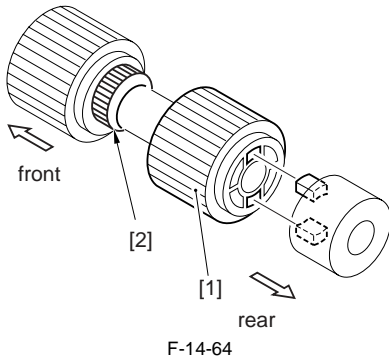

#### 14.8.4 Adjusting the Pressure of the Deck/Cassette Separation Roller

iR5065 / iR 5055 / iR5075 / iR5075N / iR5065N / iR5055N

When picking up, if double feeding or pickup failure occurs, adjust the position of the pressure spring in the separation roller.

- If double feeding occurs, move the hook of the spring in the direction of B.
- If pickup failure occurs, move the hook of the spring in the direction of A.

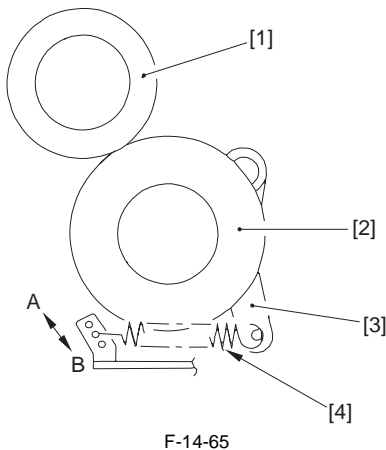

- [1] Feeding roller
- [2] Separation roller
- [3] Pressure lever
- [4] Pressure spring

#### 14.8.5 Adjusting the Pressure of the Manual Separation Roller

iR5065 / iR 5055 / iR5075 / iR5075N / iR5065N / iR5055N

When picking up, if double feeding or failure occurs, adjust the position of the pressure spring of the separation roller.

- 1) Detach the right cover (upper).
- 2) Remove the upper guide [1].

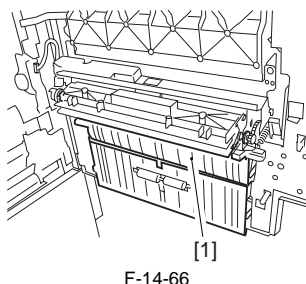

- 3) Move the mount [3] to adjust the position of the pressure spring of the sep-

aration roller.

- If double feeding occurs, remove the mounting screw [2], lower the mounting base [3] and tighten the screw [2] in the A hole.
- If pickup failure occurs, remove the mounting screw [2], raise the mounting base [3] and tighten the screw [2] in the B hole.

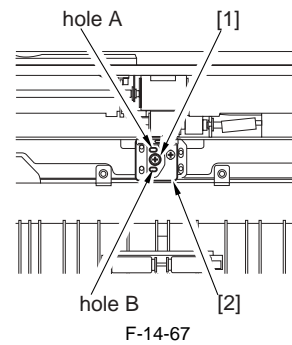

#### 14.8.6 Adjusting the Position of the Pickup Solenoid (SL3, SL4) of the Cassette 3/4

iR5065 / iR 5055 / iR5075 / iR5075N / iR5065N / iR5055N

Adjust the position of the solenoid using the two screws [3] so that the distance from the bottom of the pickup assembly to A of the roller arm is 36/+0.5 mm when [1] and [2] are op-erated.

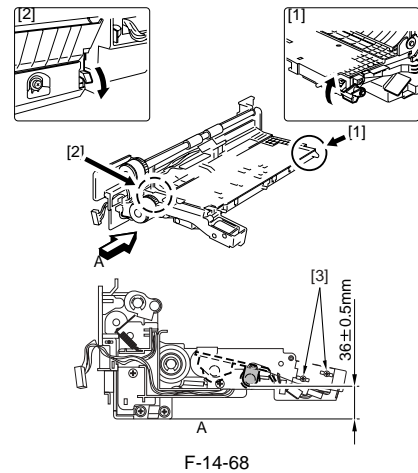

#### 14.8.7 Adjusting the Position of the Delivery Flapper Solenoid (SL5)

iR5065 / iR 5055 / iR5075 / iR5075N / iR5065N / iR5055N

Adjust the position of the mounting screw [2] using the screw [2] so that the drive lever [1] is pushed fully when the solenoid turns on (i.e., when the plunger is drawn).

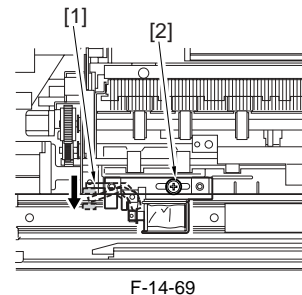

#### 14.8.8 Adjusting the Position of the Right Deck Pickup Solenoid (SL6)

iR5065 / iR 5055 / iR5075 / iR5075N / iR5065N / iR5055N

Adjust the position of the solenoid so that the left edge of the arm 2 is 57.2 -/+0.5 mm from the center of hole A of the solenoid mounting base.

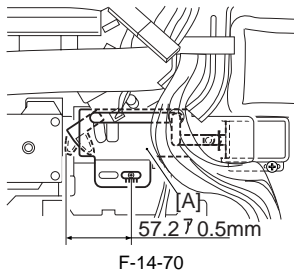

F-14-70

### 14.8.9 Adjusting the Position of the Left Deck Pickup Solenoid

iR5065 / iR 5055 / iR5075 / iR5075N / iR5065N / iR5055N

Before removing the left deck pickup solenoid from the support plate [1], take note of its position with reference to the fixing screw [2] of the solenoid. Or, mark the position for the solenoid by drawing a line on the support plate with a scriber. When mounting the solenoid on its own, be sure to secure it in its original position.

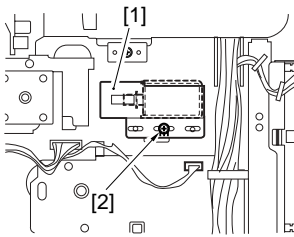

F-14-71

### 14.8.10 Mounting the Reversing Flapper Solenoid

iR5065 / iR 5055 / iR5075 / iR5075N / iR5065N / iR5055N

**!** Before removing the screw, make sure to mark the line in the following step.

- 1) Adjust the position of the solenoid using the 2 screws [1] so that the driver lever [2] is pushed fully when the solenoid is on (i.e., when the plunger is down)

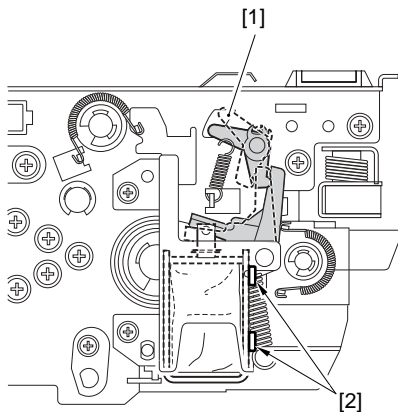

F-14-72

### 14.8.11 Attaching the Side Guide Timing Belt in the Manual Feed Tray Assembly

iR5065 / iR 5055 / iR5075 / iR5075N / iR5065N / iR5055N

- 1) Butt the rack plate [1] of the manual feed tray against section A (open state).
- 2) Move the slide volume in the direction of B, and attach the timing belt [2] onto the pulley [3].

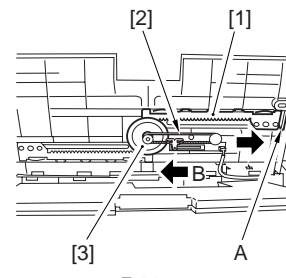

F-14-73

### 14.8.12 Adjusting the Position of the Lifter Motor M20/M21 of the Cassette 3/4

iR5065 / iR 5055 / iR5075 / iR5075N / iR5065N / iR5055N

- 1) Remove the cable from the wire saddle, and detach the guide plate [3].
  - 1 connector [1]
  - 3 screws [2]

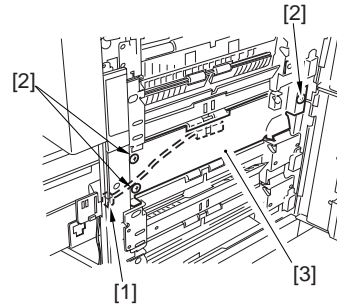

F-14-74

- 2) While keeping the lifter motor M21/M21 [1] to the right side, tighten the screw [2] temporarily.

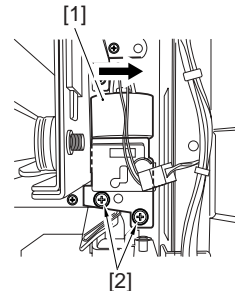

F-14-75

- 3) Set the cassette 3/4 in the machine without paper.
- 4) Check to make sure the lifer drive gear [1] is engaged with the lifter motor gear [2] from the right side of the machine.
- 5) Check to make sure the lifter drive gear is fully away from the lifter motor gear when the release button of the cassette 3/4 [3] is pressed halfway.

**!** The condition of “pressing released button halfway” is following.  
 - Separation roller should move down.  
 - The cassette roller is about to slide out.

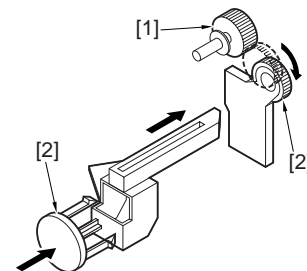

F-14-76

- 6) If the lifter drive gear is not away from the lifter motor, move the position of the lifter motor M20/M21 [1] to the left and check again with keeping the release button of the cassette 3/4 pressed halfway.

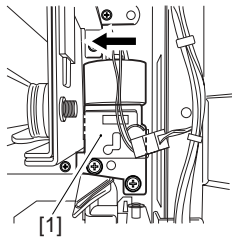

F-14-77

- 7) Fully tighten the 2 screws of the lifter motor M20/M21.
- 8) Mount back the removed parts and turn the machine on.
- 9) Check to make sure the cassette can be fully slid out when the cassette release button is pressed under the following conditions.
  - The cassette contains no paper
  - The cassette contains about 550 paper





---

## Chapter 15 Correcting Faulty Images

---



---

# Contents

15.1 Making Initial Checks .....	15-1
15.1.1 Site Environment .....	15-1
15.1.2 Checking the Originals for Symptoms.....	15-1
15.1.3 Copyboard Cover, Copyboard Glass, and Standard White Plate.....	15-1
15.1.4 Checking the Charging Assemblies .....	15-1
15.1.5 Checking the Developing Assembly.....	15-1
15.1.6 Checking the Paper .....	15-1
15.1.7 Checking the Periodically Replaced Parts .....	15-1
15.1.8 Image Adjustment Basic Procedure .....	15-1
15.1.9 Others .....	15-1
15.2 Outline of Electrical Components .....	15-2
15.2.1 Clutch/Solenoid.....	15-2
15.2.1.1 Clutches and Solenoids .....	15-2
15.2.2 Motor.....	15-3
15.2.2.1 Motors .....	15-3
15.2.3 Fan.....	15-6
15.2.3.1 Fans .....	15-6
15.2.4 Sensor.....	15-8
15.2.4.1 Sensors .....	15-8
15.2.5 Switch .....	15-13
15.2.5.1 Switches .....	15-13
15.2.6 Lamps, Heaters, and Others .....	15-14
15.2.6.1 Lamps, Heaters, and Others .....	15-14
15.2.7 PCBs .....	15-16
15.2.7.1 PCBs .....	15-16
15.2.8 Connectors .....	15-18
15.2.8.1 Connectors.....	15-18
15.2.9 Variable Resistors (VR), Light-Emitting Diodes (LED), and Check Pins by PCB.....	15-25
15.2.9.1 Variable Resistors (VR), Light-Emitting Diodes, and Check Pins by PCB .....	15-25
15.2.9.2 DC Controller PCB .....	15-25
15.2.9.3 DC Power Supply PCB .....	15-26
15.2.9.4 HVT PCB .....	15-26



---

## 15.1 Making Initial Checks

---

### 15.1.1 Site Environment

iR5065 / iR 5055 / iR5075 / iR5075N / iR5065N / iR5055N

The site must meet the following requirements:

- 1) The main source of power must provide the rated voltage. (The power plug must remain connected throughout the night.)
- 2) The site must not be subject to high temperature/humidity (near a water faucet, water boiler, humidifier) or low temperature. It must not be near a source of fire, and must not be subject to dust.
- 3) The site must not be subject to ammonium gas.
- 4) The site must be free of the direct rays of the sun; otherwise, curtains must be provided to block out the rays.
- 5) The room must be well ventilated.
- 6) The floor must keep the machine level.
- 7) The source of power must provide power night and day.

### 15.1.2 Checking the Originals for Symptoms

iR5065 / iR 5055 / iR5075 / iR5075N / iR5065N / iR5055N

Try to find out where the problem is caused by the originals or the machine:

- 1) The copy density is optimum when it is as indicated by the index (5 +/- 1).
- 2) An original with a reddish background prevents good contrast; e.g., red slips.
- 3) Check the original for density:

---

#### MEMO:

A diazo copy (used as an original) or an original with transparency tends to produce prints that are likely to be judged "foggy".  
An original prepared in pencil tends to produce prints that are likely to be judged "light".

---

### 15.1.3 Copyboard Cover, Copyboard Glass, and Standard White Plate

iR5065 / iR 5055 / iR5075 / iR5075N / iR5065N / iR5055N

Check the copyboard cover, copyboard glass, and standard white plate for dirt and scratches. If soiled, clean it with mild detergent or alcohol; if scratched, replace it.

### 15.1.4 Checking the Charging Assemblies

iR5065 / iR 5055 / iR5075 / iR5075N / iR5065N / iR5055N

- 1) Check each charging assembly for soiling and each charging wire for a fault (scratch, rust, etc.).
- 2) Clean the charging wire of each charging assembly and the shielding plate; if the dirt is excessive, replace it.
- 3) Check the type and the height of each charging assembly.
- 4) Check to make sure that each charging assembly is correctly mounted.
- 5) Check the charging wire cleaning pad (of each charging assembly) for displacement.

### 15.1.5 Checking the Developing Assembly

iR5065 / iR 5055 / iR5075 / iR5075N / iR5065N / iR5055N

- 1) Check to make sure that the rolls on both ends of the developing assembly are in contact with the drum.  
Otherwise, "light images" may occur.
- 2) Check to make sure that the surface of the developing cylinder is coated with an even layer of toner.  
Otherwise, "light images" or "uneven density" may occur.

### 15.1.6 Checking the Paper

iR5065 / iR 5055 / iR5075 / iR5075N / iR5065N / iR5055N

- 1) Check to see if the paper is of a recommended type.  
Advise the user that the use of paper not of a recommended type may not bring about the best image quality.
- 2) Check to find out if the paper is moist.  
Try using paper fresh out of package.  
Advise the user that the use of moist paper will adversely affect transfer, generating poor images. Advise him/her on the correct method of storing paper.

### 15.1.7 Checking the Periodically Replaced Parts

iR5065 / iR 5055 / iR5075 / iR5075N / iR5065N / iR5055N

Check with the Scheduled Servicing Chart and the Periodically Replaced Parts Table; if any part has reached the end of its life, replace it.

### 15.1.8 Image Adjustment Basic Procedure

iR5065 / iR 5055 / iR5075 / iR5075N / iR5065N / iR5055N

If the prints have uneven density (difference in density between front and rear), light images, or foggy background, perform the Image Adjustment Basic Procedure.

### 15.1.9 Others

iR5065 / iR 5055 / iR5075 / iR5075N / iR5065N / iR5055N

Bringing in a machine from a cold to warm room in winter for installation can cause condensation inside the machine, leading to various problems.

---

#### MEMO:

- 1) Condensation in the scanner (glass, mirror, lens) can cause dark images.
  - 2) Condensation in the charging system can cause electrical leakage.
  - 3) Condensation on the pickup/feeding guide plate can cause paper feeding faults.  
If condensation is noted, dry wipe the parts, or leave the machine alone while powered for 60 min or so.
-

## 15.2 Outline of Electrical Components

### 15.2.1 Clutch/Solenoid

#### 15.2.1.1 Clutches and Solenoids

iR5065 / iR 5055 / iR5075 / iR5075N / iR5065N / iR5055N

##### <Reader Unit>

The reader unit does not have clutches and solenoids.

##### <Printer Unit>

T-15-1

Notation	Name	Description	Remarks
CL1	developing cylinder clutch	drives the developing cylinder	
CL2	registration clutch	drives the registration roller	
CL3	manual feed pickup clutch	drives the manual feed pickup roller	
CL4	left deck pull-off clutch	drives the left deck pull-off roller	
SL1	fixing inlet guide drive solenoid	drives the fixing inlet guide	
SL2	manual feed pickup solenoid	drives the manual feed pickup solenoid release	
SL3	cassette 3 pickup solenoid	drives the cassette 3 pickup	
SL4	cassette 4 pickup solenoid	drives the cassette 4 pickup	
SL5	delivery flapper solenoid	drives the delivery flapper	
SL6	right deck pickup solenoid	drives the right deck pickup	
SL7	left deck pickup solenoid	drives the left deck pickup	
SL8	reversing flapper solenoid	drives the reversing flapper	
SL9	fixing web drive solenoid	drives the fixing web	

T-15-2

Notation	Parts No.	PART-CHK	Duplexing drive PCB	Motor driver PCB	DC controller PCB
CL1	FK2-0852	CL>4			J108
CL2	FK2-0856	CL>5			J106
CL3	FK2-0851	CL>1			J108
CL4	FK2-0850	CL>2			J115
SL1	FK2-0841	SL>9 (recover) (SL10) (plunger drawn)			J106
SL2	FK2-0832	SL>5			J108
SL3	FH7-5702	SL>3			J110
SL4	FH7-5702	SL>4			J110
SL5	FK2-0835	SL>7			J106
SL6	FK2-0836	SL>1		J2105/ J2101	J104
SL7	FK2-0836	SL>2			J102
SL8	FK2-0838	SL>8	J2306/ J2302		J107
SL9	FK2-0839	SL>11			J106

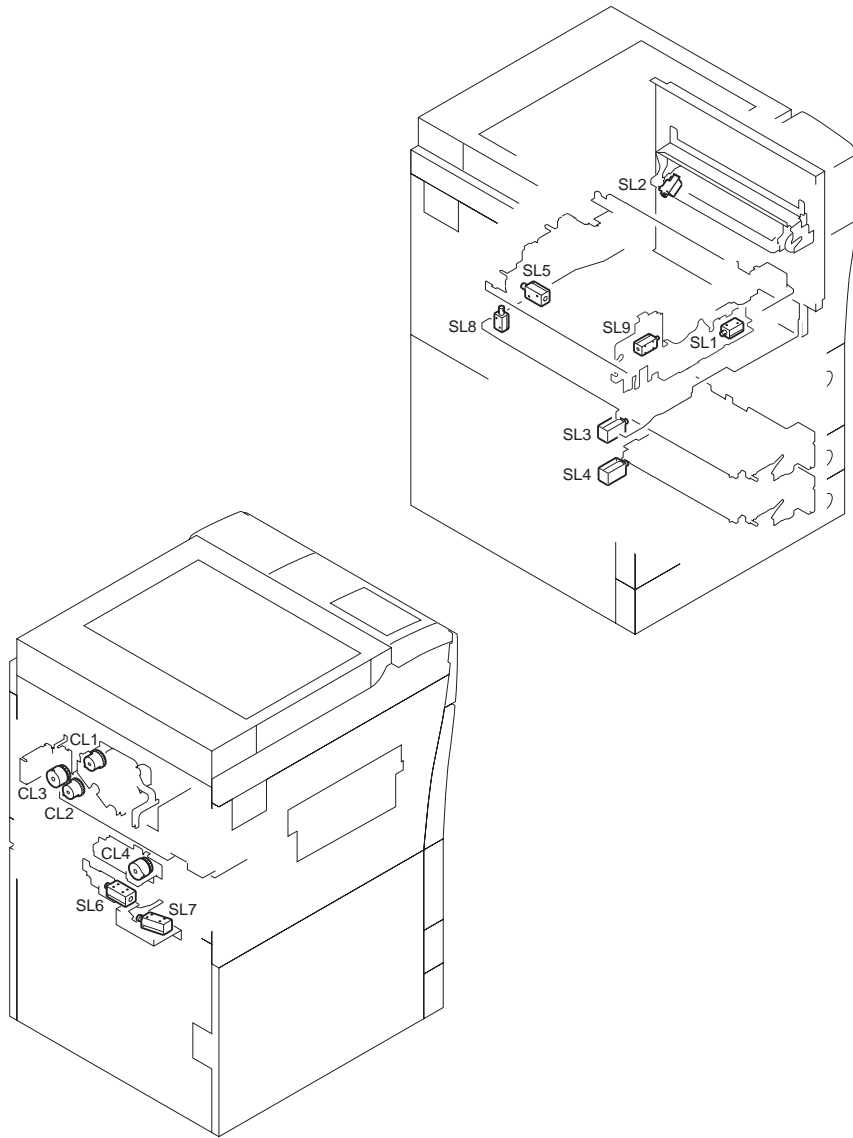

F-15-1

**15.2.2 Motor**

**15.2.2.1 Motors**

iR5065 / iR 5055 / iR5075 / iR5075N / iR5065N / iR5055N

<Reader Unit>

T-15-3

Notation	Name	Description	Parts No.	E code
M501	scanner motor	drives the No. 1/No. 2 mirror base	FK2-3773	E202

T-15-4

Notation	Connector	
	I/F PCB	reader controller PCB
M501	J306/308	J202

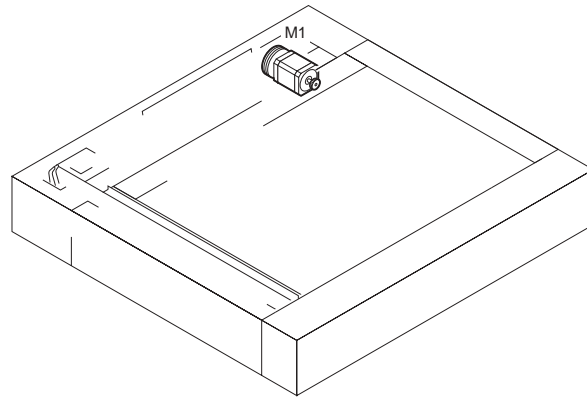

F-15-2

## &lt;Printer Unit&gt;

T-15-5

Notation	Name	Description	Remarks
M1	drum motor	drives components associated with the photosensitive drum	
M2	main motor	drives major components of the printer unit	
M3	fixing motor	drives the fixing assembly	
M4	right deck lifter motor	drives the Lifter of the right deck	
M5	Left deck lifter motor	drives the lifter of the left deck	
M6	primary charging wire cleaning motor	drives the primary charging wire cleaner	
M7	pre-transfer charging wire cleaning motor	drives the pre-transfer charging wire cleaner	
M8	transfer separation charging wire cleaning motor	drives the transfer separation charging wire cleaner	
M9	hopper stirring motor	stirs toner inside the sub hopper, supplies toner to the developing assembly	
M10	toner supply motor	supplies toner from the toner bottle	
M11	right deck pickup motor	drives the right deck pickup	
M12	cassette 3/4 pickup motor	drives cassette 3/4 pickup	
M13	delivery motor	drives the delivery assembly	
M14	reversal motor	drives the reversing assembly	
M15	shutter motor	drives the fixing assembly shutter	
M16	duplexing horizontal registration motor	drives the horizontal registration mechanism of the duplexing assembly	
M17	pre-registration motor	drives the pre-registration roller	
M18	duplexing feed right motor	drives the right side of the duplexing feed assembly	
M19	duplexing feed left motor	drives the left side of the duplexing feed assembly	
M20	cassette 3 lifter motor	drives the lifter of the cassette 3	
M21	cassette 4 lifter motor	drives the lifter of the cassette 4	
M22	laser scanner motor	drives the polygon mirror	
M24	left deck pickup motor	drives the left deck pickup mechanism	
M25	vertical path duplexing feed motor	drives the curl-imparting roller, drives the duplexing outlet roller	
M26	vertical upper motor	drives the pickup vertical path 1/2 roller	
M27	vertical lower motor	drives the pickup vertical path 3/4 roller	



T-15-6

Notation	Parts No.	PART-CHK	Error
M1	FK2-3689	MTR>2	E012-0000
M2	FK2-3491	MTR>3	E010-0000
M3	FK2-3690	MTR>4	E014-0000
M4	FK2-0017	MTR>25	
M5	FK2-0017	MTR>26	
M6	FH5-1138	MTR>17	
M7	FH6-1038	MTR>18	
M8	FH6-1038	MTR>19	
M9	FK2-0813	MTR>20 (CW) MTR>21(CCW)	
M10	FK2-0015	MTR>22	
M11	FK2-3475	MTR>5	
M12	FK2-3475	MTR>7	
M13	FK2-0827	MTR>14	
M14	FK2-4564	MTR>12	
M15	FK2-0828	MTR>24	
M16	FK2-0144	MTR>23	
M17	FK2-4563	MTR>15	
M18	FK2-0826	MTR>13	
M19	FK2-0826	MTR>16	
M20	FK2-0814	MTR>27	
M21	FK2-0814	MTR>28	
M22	FM2-0018	MTR>1	E110-0001
M24	FK2-3475	MTR>6	
M25	FK2-0824	MTR>8	
M26	FK2-0820	MTR>10	
M27	FK2-0822	MTR>9	

T-15-7

Notation	Duplexing drive PCB	Motor driver PCB	Video PCB	DC controller PCB
M1				J108
M2				J108
M3				J106
M4		J2105/J2113		J105
M5		J2105/J2113		J105
M6				J103
M7				J103
M8				J106
M9				J103
M10				J103
M11		J2102/J2101		J104
M12		J2104/J2101		J104
M13				J106
M14	J2305/J2302			J107
M15				J128

Notation	Duplexing drive PCB	Motor driver PCB	Video PCB	DC controller PCB
M16	J2306/J2302			J107
M17		J2102/J2101		J104
M18	J2307/J2302			J107
M19	J2305/J2302			J107
M20				J113
M21				J113
M22			J1406/	J116
M24		J2103/J2101		J104
M25		J2112/J2101		J104
M26		J2102/J2101		J104
M27		J2110/J2101		J104

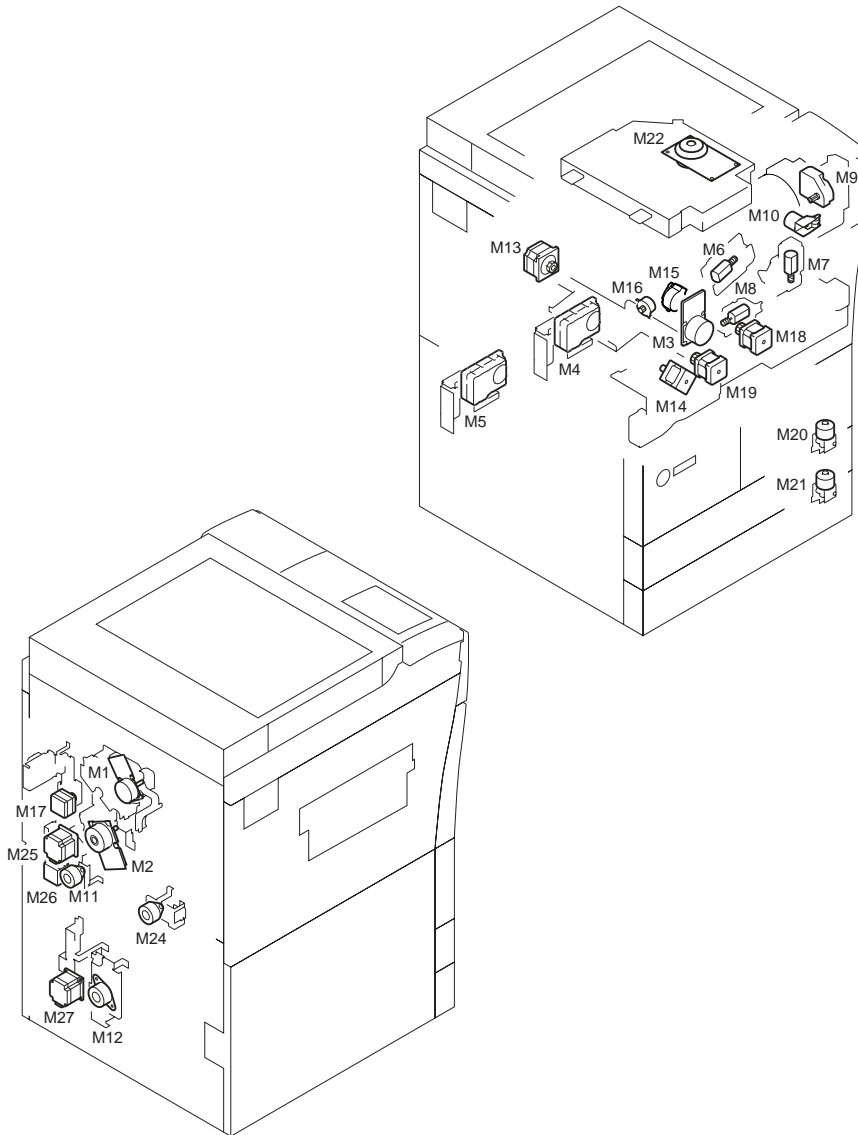

F-15-3

### 15.2.3 Fan

#### 15.2.3.1 Fans

iR5065 / iR 5055 / iR5075 / iR5075N / iR5065N / iR5055N

<Reader Unit>

T-15-8

Notation	Name	Description	Parts No.	Connector	
				Interface PCB	Reader controller PCB
FM501	reader unit cooling fan	cools the reader unit	FK2-0636	J313/J308	J202

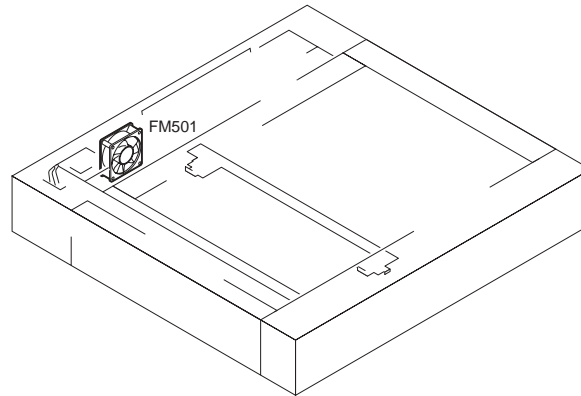

F-15-4

## &lt;Printer Unit&gt;

T-15-9

Notation	Name	Description
FM1	feed fan	discharges heat from the fixing unit
FM2	primary charging cooling fan	cools the primary charging assembly and the cleaner
FM3	heat discharge fan	discharges exhaust from fans to the outside of the machine
FM4	controller cooling fan	cools the laser assembly, developing assembly, drive assembly, controller
FM5	curl-removing fan	removes curl from print paper after fixing
FM6	DC power supply fan	cools the power supply PCB
FM7	fixing heater power supply cooling fan	cools the power supply for fixing
FM8	duplexing feed fan	cools the duplexing feed motor
FM9	circulation duct fan	cools the inside of the machine
FM10	accessories power supply cooling fan	cools the accessories power supply
FM11	HVT fan	cools the HVT unit

T-15-10

Notation	Parts No.	I/O	Error
FM1	FH5-1117	P013-0: half-speed P013-1: full-speed	1:ON E805-0002
FM2	FK2-0103	P013-2: half-speed P013-3: full-speed	1:ON 1:OM E824-0001
FM3	FH5-1118	P013-6: half-speed P013-7: full-speed	1:ON 1:ON E805-0001
FM4	FK2-0844	P014-2: half-speed P014-3: full-speed	1:ON 1:ON E121-0001
FM5	FH6-1548	P014-6: half-speed P014-7: full-speed	1:ON 1:ON -
FM6		P012-3	1:ON E804-0000
FM7	FK2-0795	P014-0 P014-1	1:ON 1:ON E804-0001
FM8	FH6-1742	P014-5	1:ON -
FM9	FK2-0103	P023-2	1:ON -
FM10	FK2-0472	P015-1: half-speed P015-2: full-speed	1:ON E804-0002
FM11	FH6-1742	P013-4: half-speed P013-5: full-speed	1:ON -

Notation	DC power supply PCB	Duplexing PCB	DC controller PCB
FM1			J109
FM2			J103
FM3			J111
FM4			J108
FM5			J106
FM6	PN4001/J4002		J102
FM7			J124
FM8		J2303/J2302	J107
FM9			J124
FM10			J6503
FM11			J137

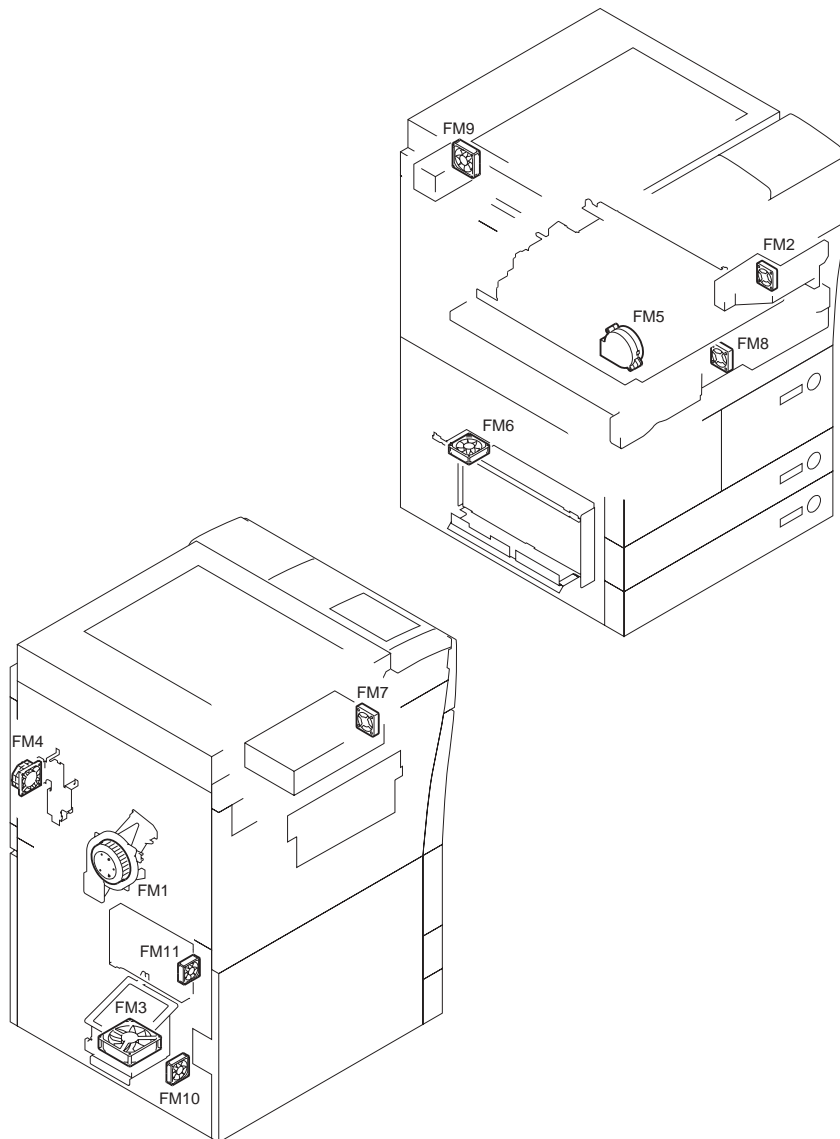

F-15-5

## 15.2.4 Sensor

### 15.2.4.1 Sensors

iR5065 / iR 5055 / iR5075 / iR5075N / iR5065N / iR5055N

<Reader Unit>

T-15-12

Notation	Name	Description	Parts No.	Connector No.	
				Interface PCB	Reader controller PCB
SR1	ADF open/closed 1 sensor	detects the state (open/closed) of the ADF	FK2-0149	J310/308	J202
SR2	Scanner HP sensor	detects scanner home position	FK2-0149	J310/308	J202
SR3	ADF open/closed 2 sensor	detects the timing of original size	FK2-0149	J310/308	J202
CF1-CF4	original size sensor	detects the original size	FK2-0238		J207(AB) J208(INCH)

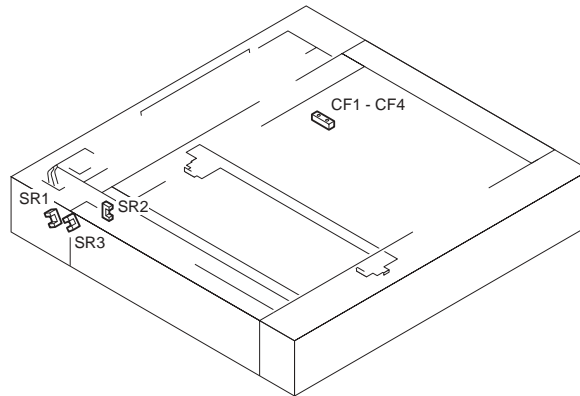

F-15-6

## &lt;Printer Unit&gt;

T-15-13

Notation	Name	Description
PS2	Right lower cover open/closed sensor	detects the Right lower cover open/closed
PS3	Manual feed tray open/closed sensor	detects the manual feed tray open/closed
PS4	Claw jam sensor	detects the claw jam
PS5	Right deck open/closed sensor	detects the right deck open/closed
PS6	Right deck lifter sensor	detects the right deck lifter
PS7	Right deck paper sensor	detects paper in the right deck
PS8	Right deck limit sensor	detects the right deck limit
PS9	Left deck open/closed sensor	detects the left deck open/closed
PS10	Left deck lifter sensor	detects the left deck lifter
PS11	Left deck paper sensor	detects paper in the left deck
PS12	Left deck limit sensor	detects the left deck limit
PS13	Cassette 3 paper sensor	detects paper in the cassette 3
PS14	Cassette 4 paper sensor	detects paper in the cassette 4
PS15	Cassette 3 open/closed sensor	detects the cassette 3 open/closed
PS16	Cassette 4 open/closed sensor	detects the cassette 4 open/closed
PS17	Cassette 3 lifter sensor	detects the cassette 3 lifter
PS18	Cassette 4 lifter sensor	detects the cassette 4 lifter
PS19	Right deck re-try sensor	detects the right deck re-try
PS20	Left deck re-try sensor	detects the left deck re-try
PS21	Cassette 3 re-try sensor	detects the cassette 3 re-try
PS22	Cassette 4 re-try sensor	detects the cassette 4 re-try
PS23	Manual feed paper sensor	detects the Manual feed paper
PS24	Vertical path 1 paper sensor	detects the vertical path 1 paper
PS25	Vertical path 2 paper sensor	detects the vertical path 2 paper
PS26	Vertical path 3 paper sensor	detects the vertical path 3 paper
PS27	Vertical path 4 paper sensor	detects the vertical path 4 paper
PS28	Laser write start sensor	detects the laser write start
PS29	Registration paper sensor	detects the registration paper
PS30	Duplex pre- registration sensor	detects the duplex pre- registration
PS31	Duplex horizontal registration sensor	detects the duplex horizontal registration
PS32	Right deck feed paper sensor	detects the right deck feed paper

Notation	Name	Description
PS33	Left deck feed paper sensor	detects the left deck feed paper
PS34	Duplexing paper sensor	detects the duplexing paper
PS35	Internal delivery sensor	detects the internal delivery
PS36	External delivery sensor	detects the external delivery
PS37	Reversal sensor 1	detects the reversal 1
PS38	Reversal sensor 2	detects the reversal 2
PS45	Fixing web length sensor	detects fixing web length
PS46	Delivery jam sensor	detects the delivery jam
PS47	Right deck level sensor (upper)	detects the right deck level (upper)
PS48	Right deck level sensor (lower)	detects the right deck level (lower)
PS49	Left deck level sensor (upper)	detects the left deck level (upper)
PS50	Left deck level sensor (lower)	detects the left deck level (lower)
PS51	Fixing inlet sensor	detects the fixing inlet
PS52	Fixing outlet sensor	detects the fixing outlet
PS53	Shutter HP sensor	detects the shutter HP
PS54	Toner access cover open/closed sensor	detects the toner access cover open/closed
UN13	Manual feed tray paper width sensor PCB	Detects the width of paper on the manual feed tray
UN14	Cassette 3 level sensor PCB	Detects the level of paper in the cassette 3
UN15	Cassette 4 level sensor PCB	Detects the level of paper in the cassette 4.
UN16	Cassette 3 paper width sensor PCB	Detects the width of paper in the cassette 3.
UN17	Cassette 4 paper width sensor PCB	Detects the width of paper in the cassette 4.
UN18	Cassette 3 paper length sensor PCB	Detects the length of paper in the cassette 3.
UN19	Cassette 4 paper length sensor PCB	Detects the length of paper in the cassette 4.

T-15-14

Notation	Parts No.	I/O		DC controller PCB	JAM
PS2	FK2-0149	P009-13	0:open	J113	
PS3	FK2-0149	P009-0	0:open	J103	
PS4	FK2-0149	P001-14	0:present	J106	xx0F
PS5	FK2-0149	P009-11	0:open	J112	
PS6	FK2-0149	-	-	J112	
PS7	FK2-0149	P001-7	1:present	J112	
PS8	FK2-0149	P002-4	1:present	J112	
PS9	FK2-0149	P009-12	0:open	J115	
PS10	FK2-0149	-	-	J115	
PS11	FK2-0149	P001-9	1:present	J115	
PS12	FK2-0149	P008-4	1:present	J115	
PS13	FK2-0149	P001-3	1:present	J110	
PS14	FK2-0149	P001-5	1:present	J110	
PS15	FK2-0149	P009-8	0:open	J110	
PS16	FK2-0149	P009-9	0:open	J110	
PS17	FK2-0149	-	-	J110	
PS18	FK2-0149	-	-	J110	
PS19	FK2-0149	P001-2	1:present	J112	xx0B
PS20	FK2-0149	P002-2	1:present	J115	xx0C
PS21	FK2-0149	P002-0	1:present	J110	xx0D
PS22	FK2-0149	P002-1	1:present	J110	xx0E
PS23	FK2-0149	P001-0	0:present	J108	
PS24	FK2-0149	P001-8	1:present	J113	xx03
PS25	FK2-0149	P001-10	1:present	J113	xx04
PS26	FK2-0149	P001-4	1:present	J110	xx05
PS27	FK2-0149	P001-6	1:present	J110	xx06
PS28	FK2-0149	P002-8	1:present	J113	xx02
PS29	FK2-0149	P001-1	1:present	J106	xx01
PS30	FK2-0149	P002-5	1:present	J107	xx16

Notation	Parts No.	I/O		DC controller PCB	JAM
PS31	FK2-0149	P002-6	0:present	J107	
PS32	FK2-0149	P009-2	1:present	J112	xx07
PS33	FK2-0149	P001-15	1:present	J107	xx08
PS34	FK2-0149	P002-11	1:present	J107	xx15
PS35	FK2-0149	P001-12	0:present	J106	xx10
PS36	FK2-0149	P001-11	1:present	J106	xx11
PS37	FK2-0149	P002-3	1:present	J107	xx14
PS38	FK2-0149	P002-7	1:present	J107	xx13
PS45	FK2-0149	P002-12	1:absent	J128	
PS46	FK2-0149	P008-09	1:present	J106	xx12
PS47	FK2-0149	P006-8	1:present	J115	
PS48	FK2-0149	P006-12	1:present	J115	
PS49	FK2-0149	P006-9	1:present	J115	
PS50	FK2-0149	P006-13	1:present	J115	
PS51	FK2-0149	P008-8	1:present	J106	xx18
PS52	FK2-0149	P002-13	1:present	J106	xx17
PS53	FK2-0149	P002-14	0:HP	J106	
PS54	FK2-0149	P009-14	0:open	J103	
UN13	FG5-6231	-	-	J108	
UN14	FG6-1941	P009-5	1:present	J113	
UN15	FG6-1941	P009-6	1:present	J113	
UN16	FG5-1957	-	-	J111	
UN17	FG5-1957	-	-	J125	
UN18	FG5-9581	-	-	J111	
UN19	FG5-9581	-	-	J125	

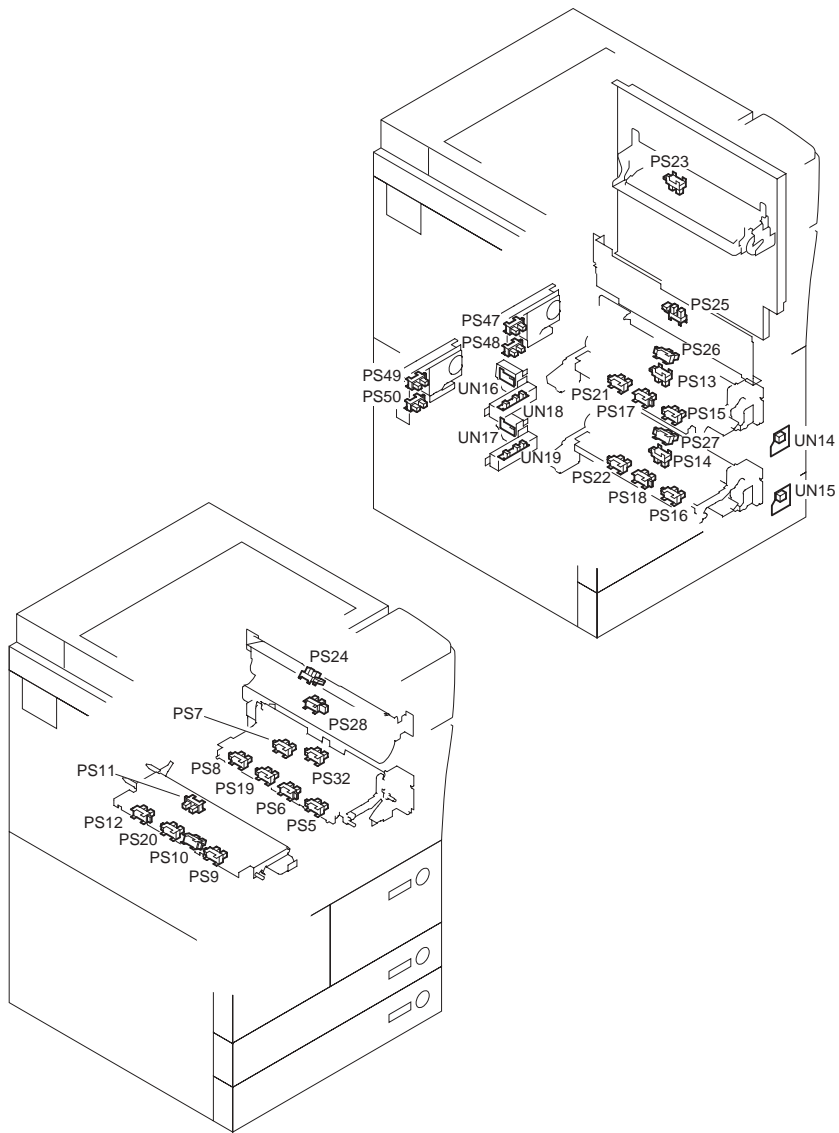

F-15-7



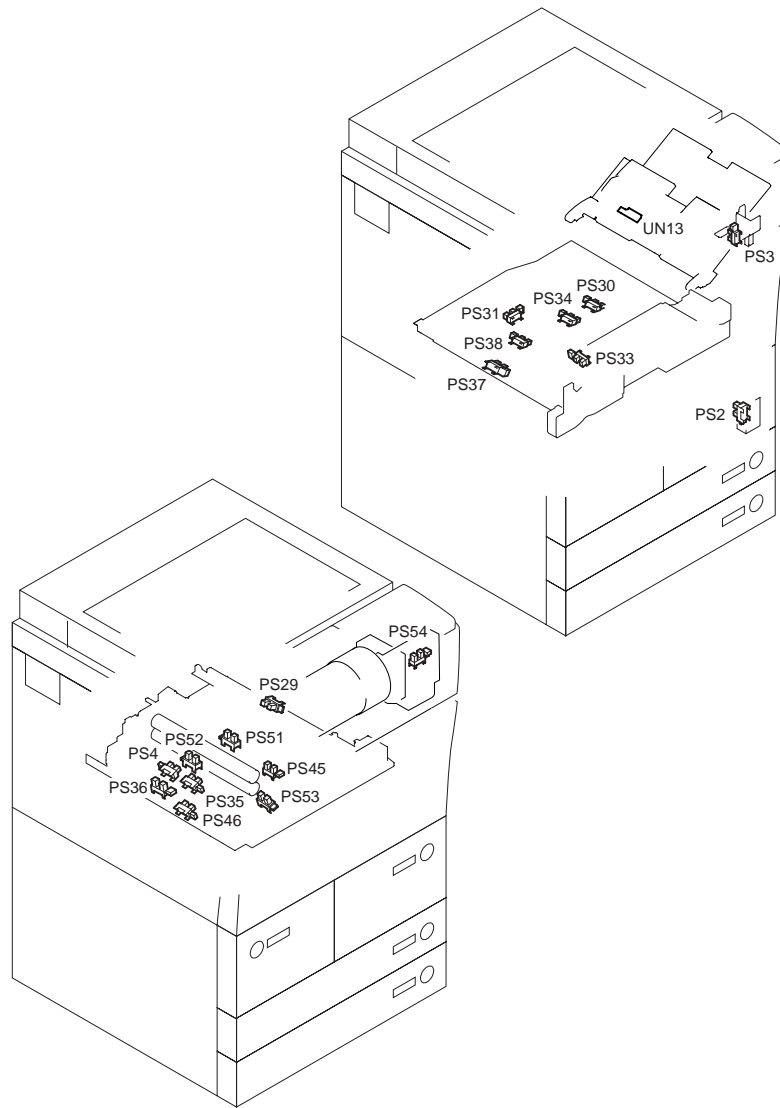

F-15-8

## 15.2.5 Switch

### 15.2.5.1 Switches

iR5065 / iR 5055 / iR5075 / iR5075N / iR5065N / iR5055N

#### <Reader Unit>

The reader unit does not have switches.

#### <Printer Unit>

T-15-15

Notation	Name	Description	Parts No.
SW1	main power switch	turns on/off the main power	FK2-0796
SW2	front cover switch	detects the state (open/closed) of the front cover	WC4-5125
SW3	environment switch	turns on/off the drum heater	WC1-5179
SW4	cassette heater switch	turns on/off the cassette heater	WC1-5179
SW5	waste toner feedscrew lock detection switch	detects the state (locked) of the collecting toner feedscrew	WC4-0153
SW6	manual feed tray open/closed detection switch	detects the state (open/closed) of the manual feed tray	WC4-5112
SW7	fixing feeding unit detection switch	detects the presence/absence of the fixing feeding unit	WC4-5112

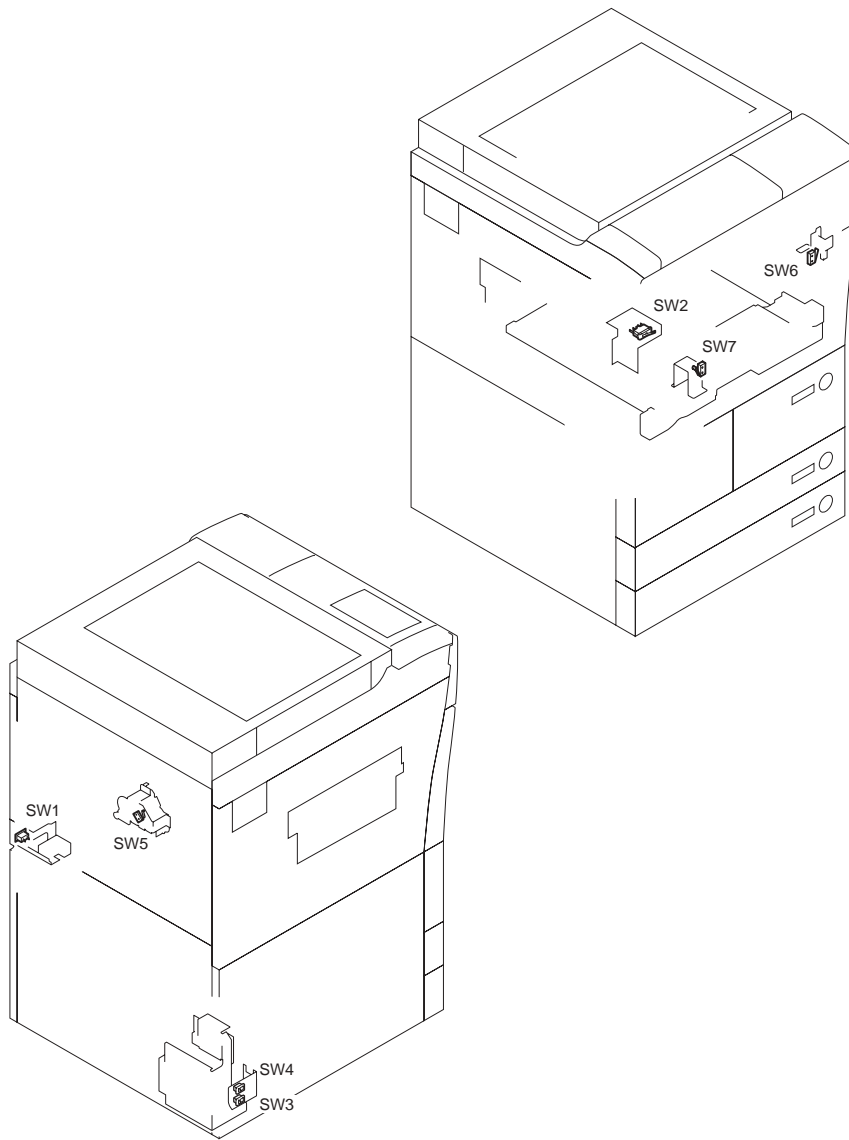

F-15-9

**15.2.6 Lamps, Heaters, and Others**

**15.2.6.1 Lamps, Heaters, and Others**

iR5065 / iR 5055 / iR5075 / iR5075N / iR5065N / iR5055N

<Reader Unit>

T-15-16

Notation	Name	Description	Parts No.
H501	lens heater	prevents condensation on the lens	F26-4601 (100V; option)
			FK2-0228 (230V; service part)
H502	mirror heater	prevents condensation on the mirror	F26-4601 (100V; option)
			FK2-0229 (230V; service part)
LA1	scanning lamp	illuminates originals	FM2-3184 (100V/230V)
			FM2-3185 (120V)

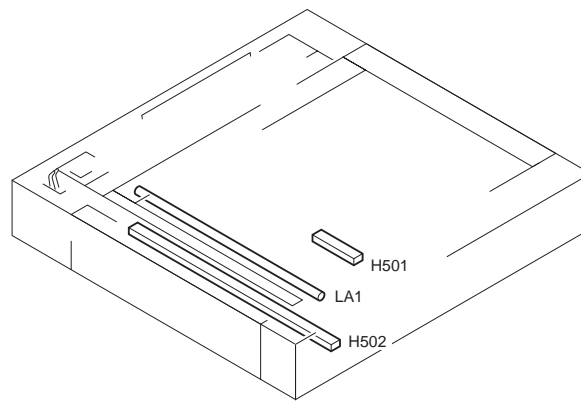

F-15-10

## &lt;Printer Unit&gt;

T-15-17

Notation	Name	Description	Parts No.
LED1	pre-exposure lamp (LED)	removes residual charges from the surface of the photosensitive drum	FK2-3694 (pre-exposure unit) iR5075/iR5075
			FH7-3412 (pre-exposure unit) iR5065/iR5065N/iR5055/iR5065
IH	fixing heater	heats the fixing roller	FK2-0807
H1	drum heater	prevents condensation on the photosensitive drum	FK2-0786 (100V)
			FK2-0787 (120V)
			FK2-0788 (230V)
H2	cassette heater	prevents condensation in cassette (dries paper inside)	FK2-0789 (100V)
			FK2-0790 (230V; service part)
THM1	fixing main thermistor	performs fixing temperature control, detects error	FK2-5252 (thermistor unit)
THM2	fixing sub thermistor	performs fixing temperature control, detects error	FK2-0811
THM3	shutter thermistor	performs fixing temperature control, detects error	FK2-5252 (thermistor unit)
TP1	fixing thermal switch	serves as a safety mechanism for the fixing assembly	FK2-0808
ELCB	leakage breaker	prevents leakage of current	FH7-7626 (100V)
			FK2-0014 (120V)
			FH7-7625 (230V)
TS1	developing assembly toner sensor	detects the level of toner remaining inside the developing assembly	FK2-0812
TS2	sub hopper toner level sensor	detects the level of toner remaining inside the hopper	FK2-0812
THU1	temperature/humidity sensor	measures the temperature/ humidity inside the machine	WP2-5200
C1	charger unit	supplementary power supply device when printer and reader are made to work at the same time	FM2-9631 iR5075/5075N only

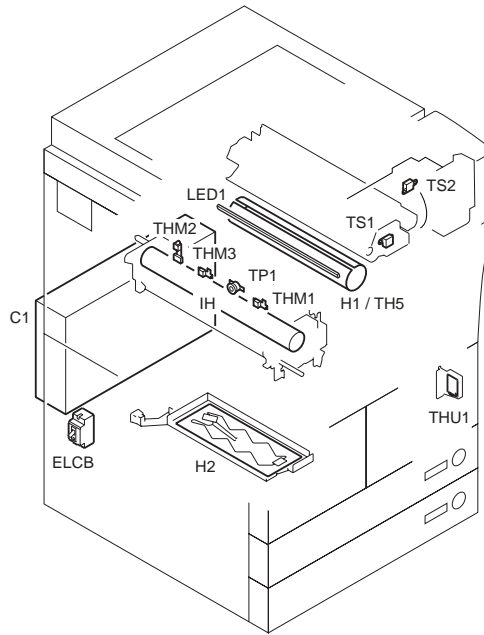

F-15-11

15.2.7 PCBs

15.2.7.1 PCBs

iR5065 / iR 5055 / iR5075 / iR5075N / iR5065N / iR5055N

<Reader Unit>

T-15-18

Ref.	Name	Description	Parts No.
[1]	interface PCB	serves as the interface with the printer and ADF	FM3-0471
[2]	Memory PCB		FM3-0472
[3]	reader controller PCB	controls the reader unit	FM3-0470
[4]	CCD/AP PCB	performs analog image processing	FM2-4818 (CCD unit)
[5]	inverter PCB	drives the scanning lamp	FK2-0630

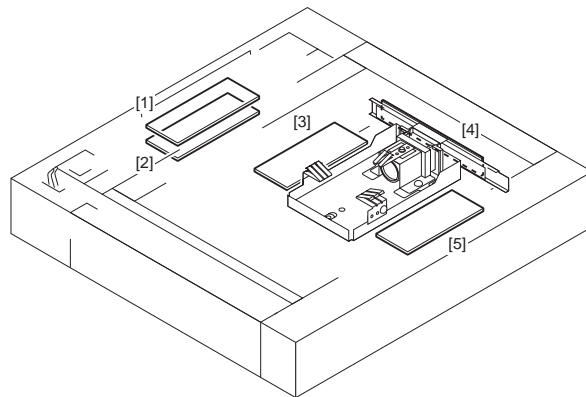

F-15-12

<Printer Unit>

T-15-19

Ref.	Name	Description	Parts No.
[1]	DC controller PCB	controls the power supply to the printer unit/finisher	FM2-9857
[2]	DC power supply PCB	supplies DC power	FK2-3472Äi100V/120VÄj FK2-3473Äi230VÄj
[3]	AC driver PCB	controls the AC circuitry	FM2-9861 (100V; AC driver unit) FM2-9861 (120V; AC driver unit) FM2-9862 (230V; AC driver unit)
[4]	motor driver PCB	controls the motor	FM2-9895

Ref.	Name	Description	Parts No.
[5]	HVT1 PCB	generates high voltage	FM2-9897 iR5065/iR5065N/iR5055/iR5055N
			FM2-9859 iR5075/iR5075N
[6]	potential PCB	controls the surface potential of the photosensitive drum	FM2-0839
[7]	drum heater control PCB	controls the drum heater	FM2-0841 (100V/120V) FM2-0842 (230V)
[8]	option power supply PCB	supplies power to the finisher	FK2-2660Åi100VÅj FK2-2661Åi230VÅj FK2-3476(100/230 universal)
[9]	duplexing drive PCB	controls the sensors, motors, and solenoids of the duplexing unit	FM2-9903
[10]	laser drive PCB	controls the laser drive	FM2-9860 (laser scanner unit)
[11]	BD developing PCB	detects the laser beam	FM2-0859 (laser scanner unit)
[12]	control panel keypad PCB	controls the keys and LEDs	FM2-1250
[13]	control panel CPU PCB	controls the control panel	FM2-1249
[14]	control panel inverter PCB	adjusts the contrast of the control panel	FM2-1251
[15]	rush-current prevention PCB	prevents rush current to the fixing feeding/duplexing unit	FG6-4978
[16]	capacitor PCB	removes noise	FM2-9864 (100V/120V; AC driver unit) FM2-9896 (230V; AC driver unit)
[17]	fixing heater power supply PCB	controls the fixing heater	FM2-3647 (100V) FM2-3648 (120V) FM2-3649 (230V)
[18]	main controller PCB	performs digital image processing/system control	FM3-0221
[19]	PCI expansion PCB	serves as a relay PCB	FM2-5430 (option)
[20]	drum cleaner thermistor PCB	detects clogging of the cleaner	FM2-3661
[21]	potential sensor PCB	measures the photosensitive drum surface potential	FM2-3657
[22]	reader relay PCB	generates high voltage	FM3-0233
[23]	Video PCB	image control	FM2-9868
[24]	Separation claw AC PCB	generating the separation claw bias	FM3-0957
[25]	Filter PCB	removing the noise	FM2-9865 (100V) FM2-9866 (120V/230V)
[26]	13V converter PCB	generates 13V	FM2-9869

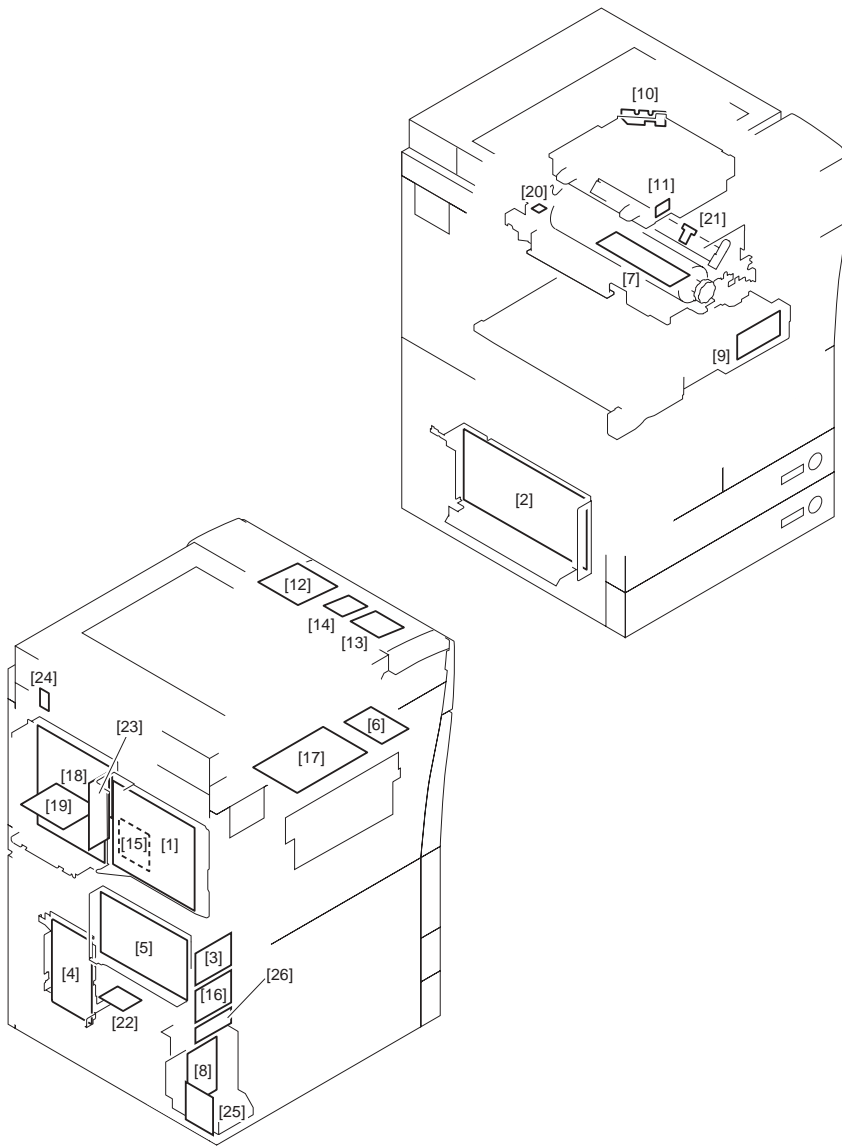

F-15-13

## 15.2.8 Connectors

### 15.2.8.1 Connectors

iR5065 / iR 5055 / iR5075 / iR5075N / iR5065N / iR5055N

<Reader Unit>

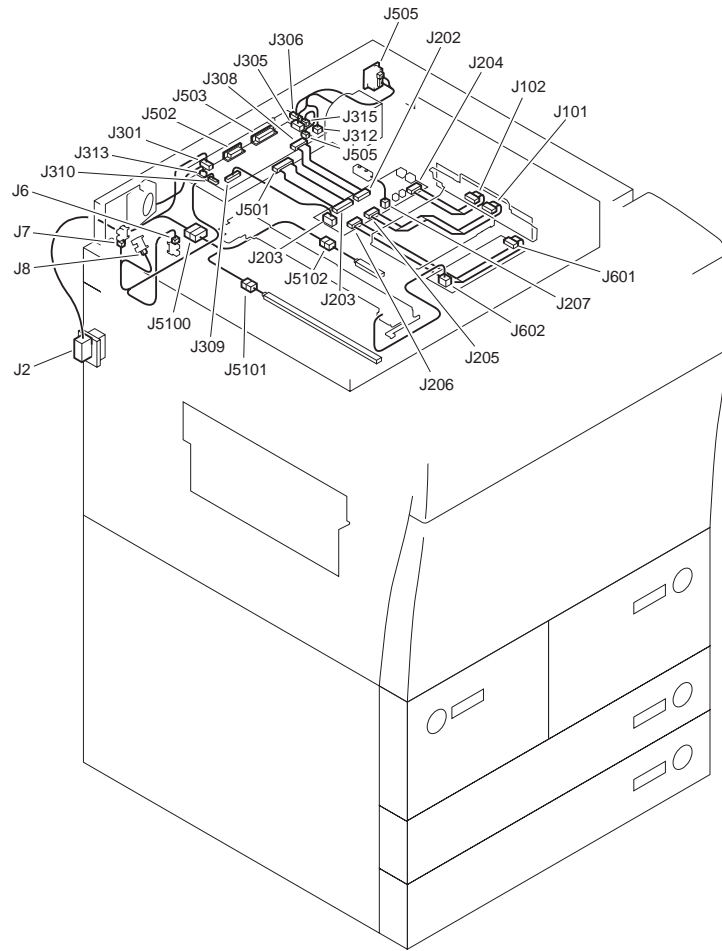

F-15-14

<Printer Unit>

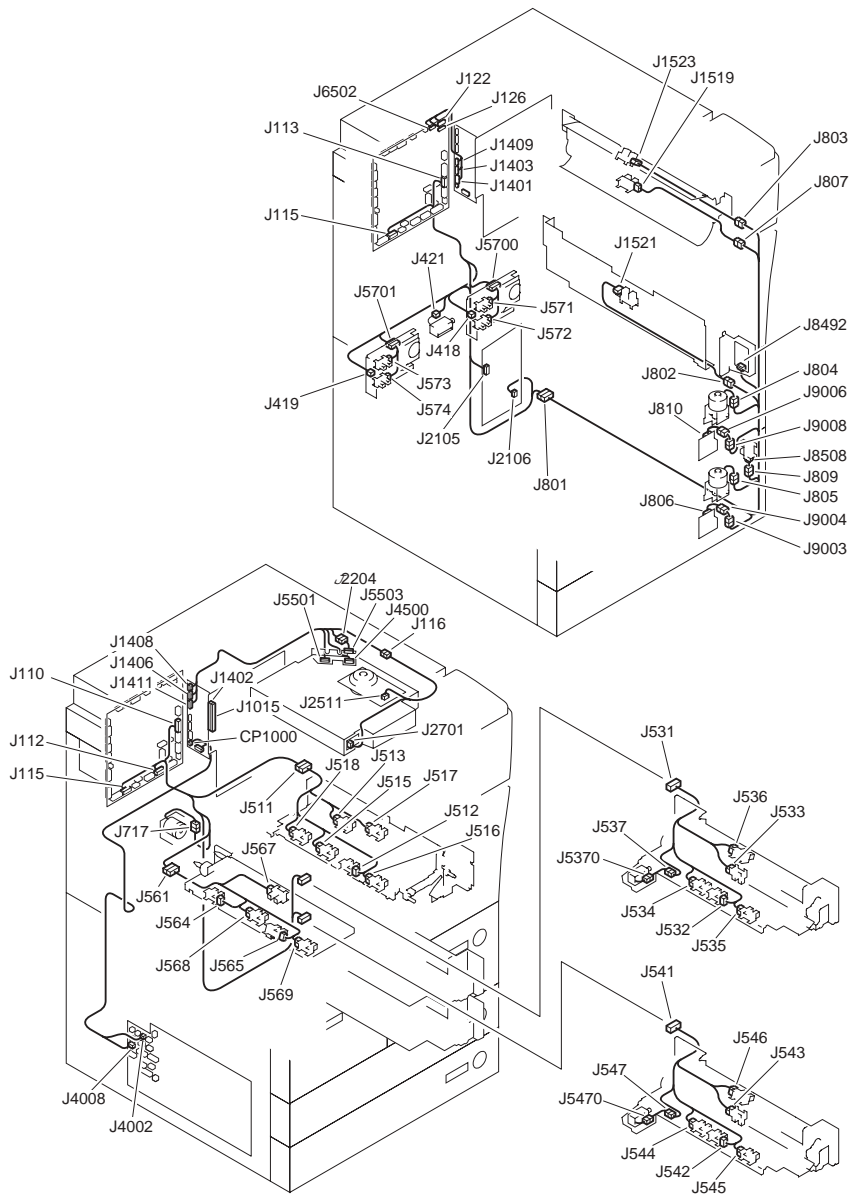

F-15-15



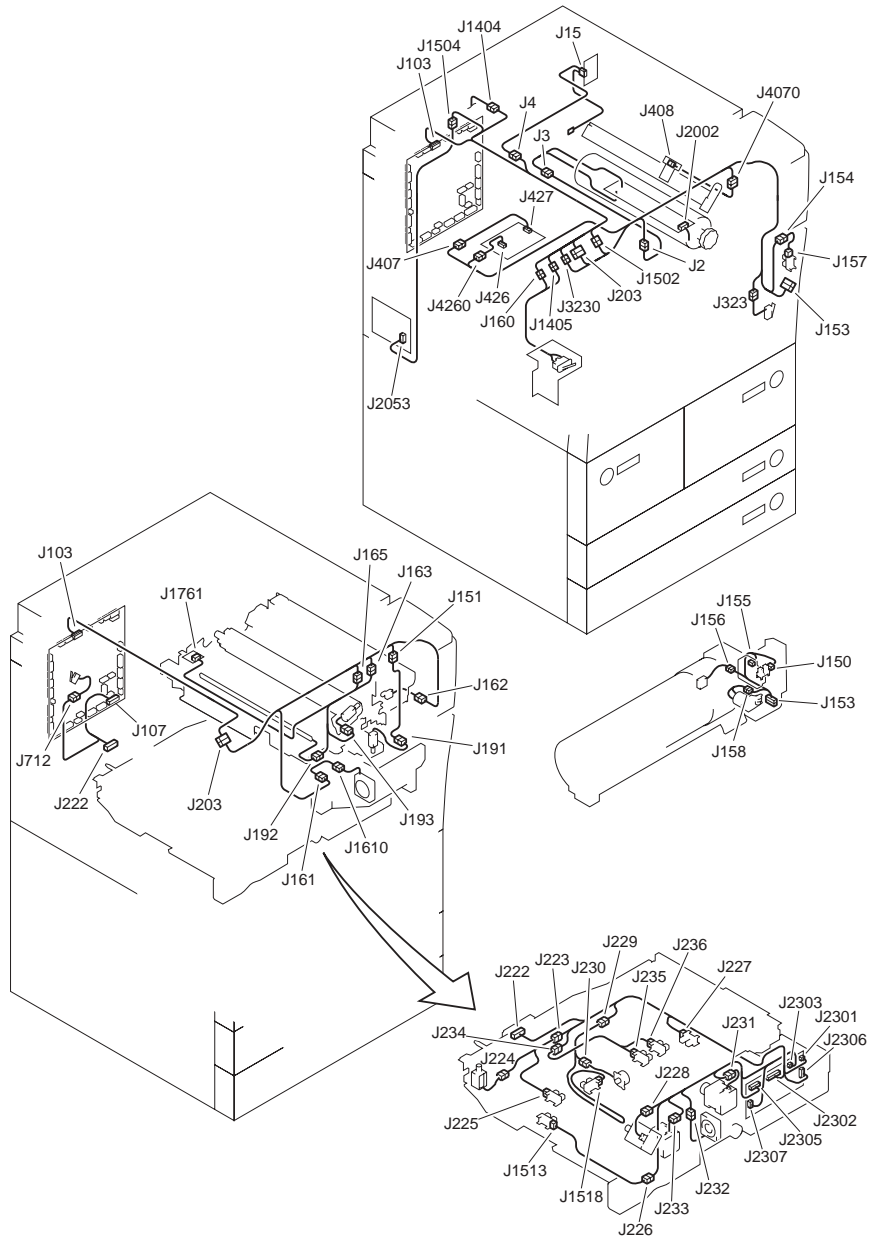

F-15-16

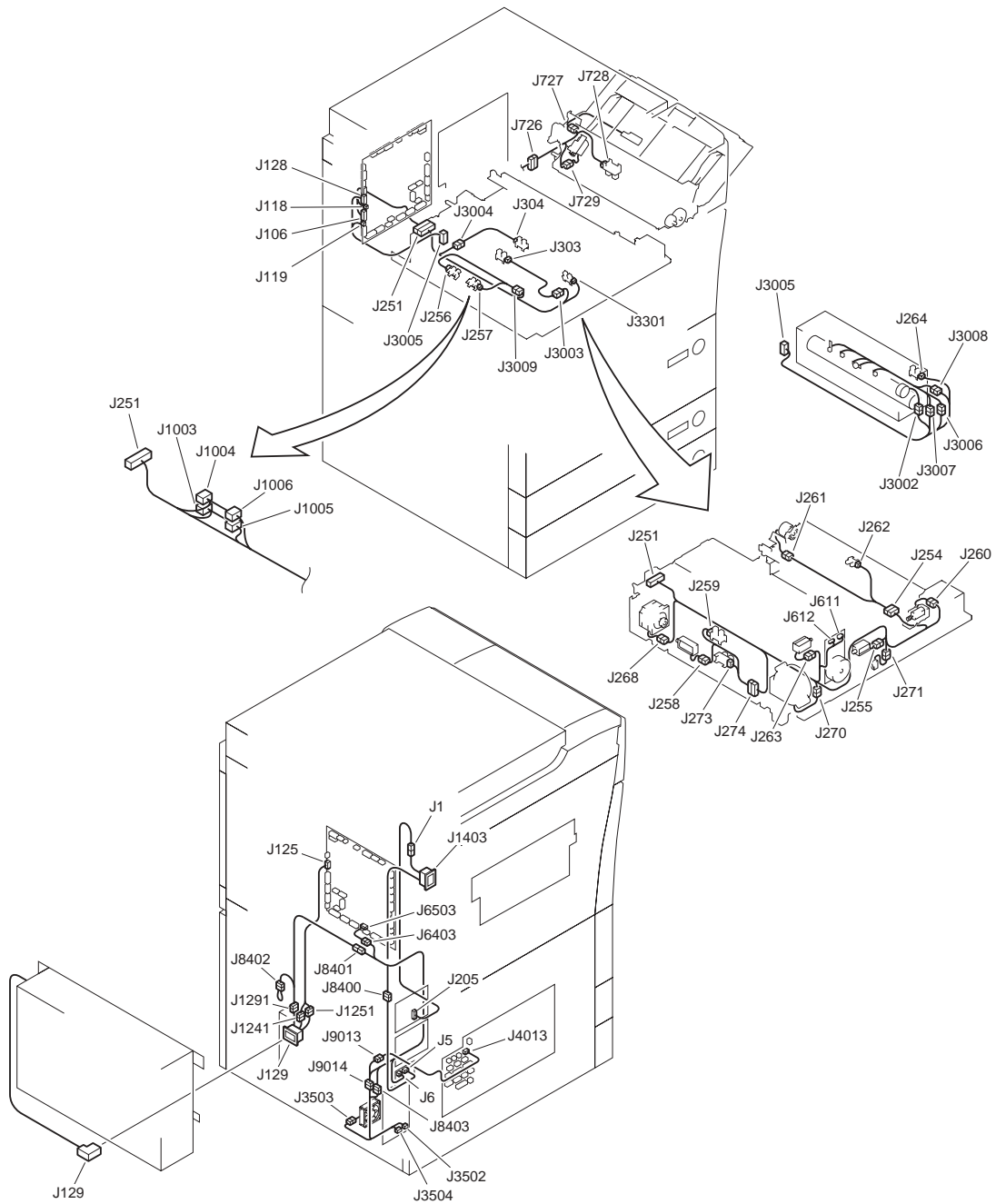

F-15-17

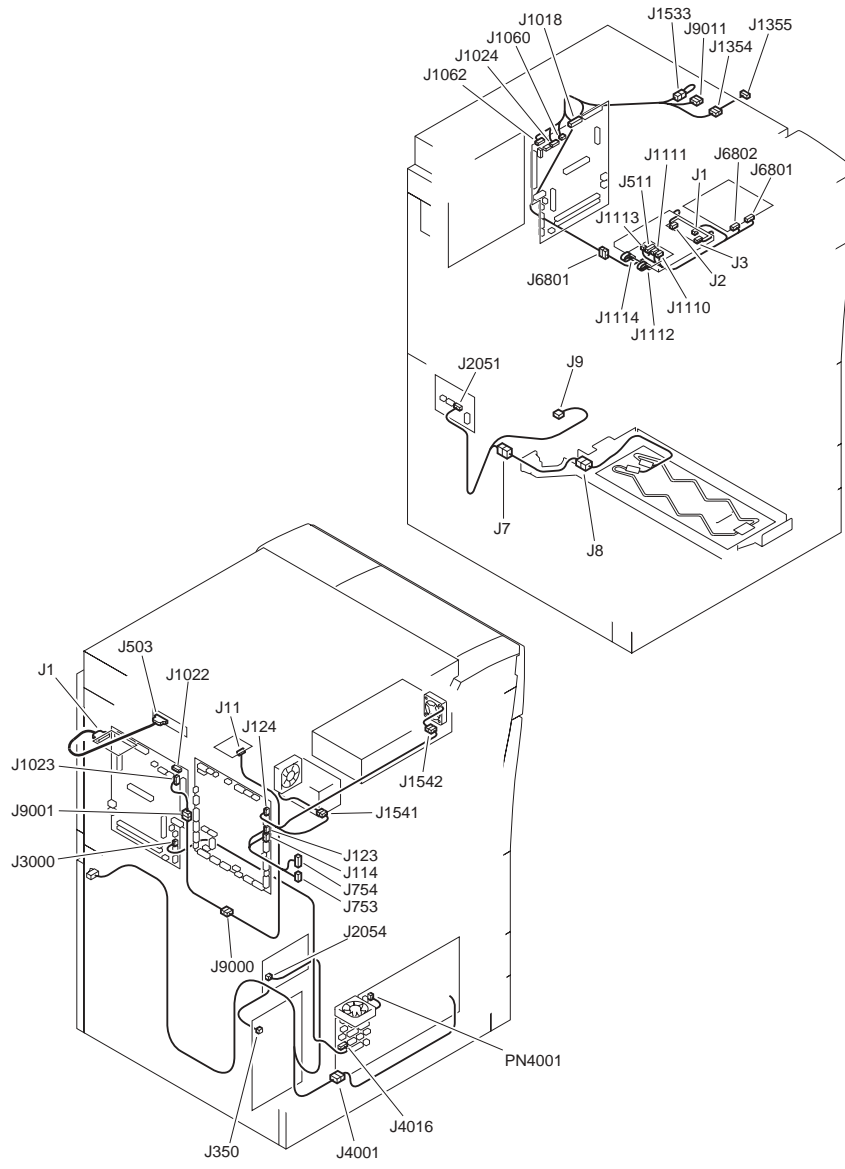

F-15-18

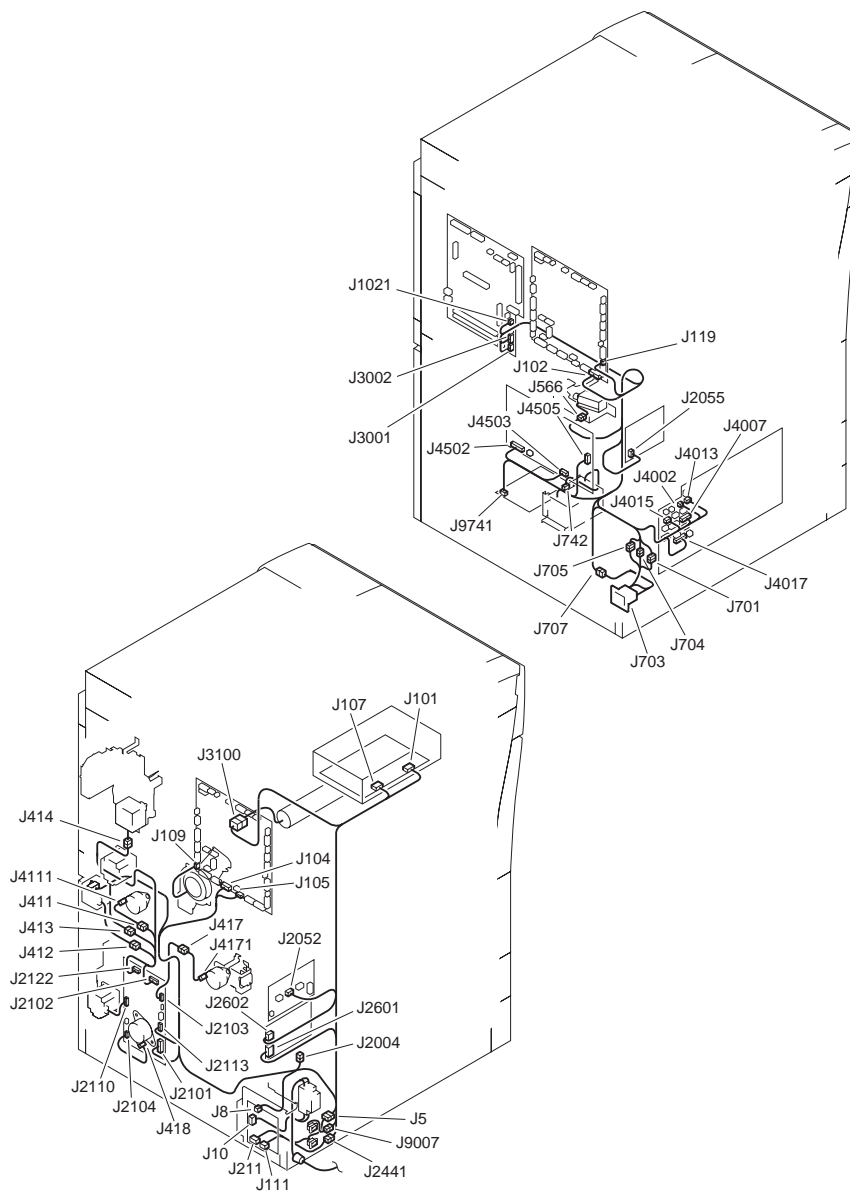

F-15-19

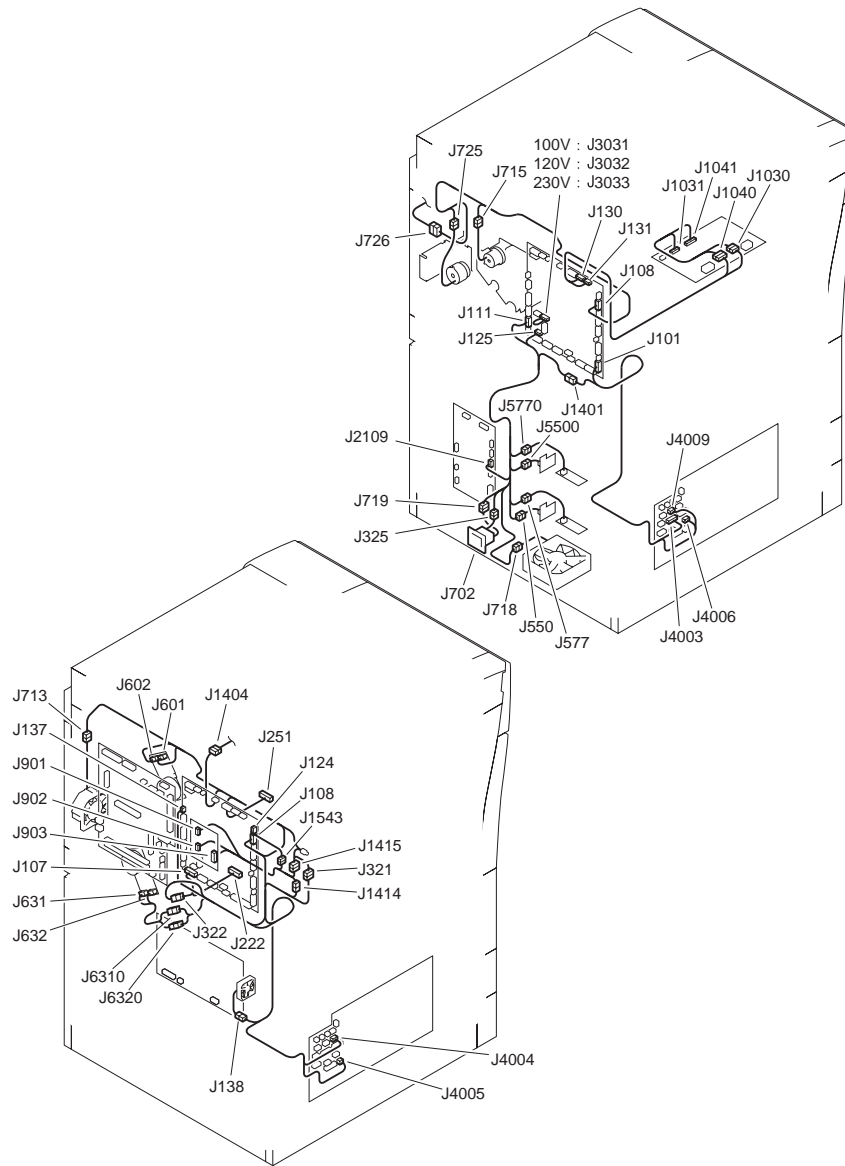

F-15-20

## 15.2.9 Variable Resistors (VR), Light-Emitting Diodes (LED), and Check Pins by PCB

### 15.2.9.1 Variable Resistors (VR), Light-Emitting Diodes, and Check Pins by PCB

iR5065 / iR 5055 / iR5075 / iR5075N / iR5065N / iR5055N

Of the variable resistors (VR), light-emitting diodes (LED), and check pins found in the machine, those that are needed when servicing the machine in the field are discussed.



- Some LEDs carry current and emit light when they are off; this is a normal condition, and must be kept in mind.
- Take note of the following:



...VR that may be used in the field.



...VR that must not be used in the field.

### 15.2.9.2 DC Controller PCB

iR5065 / iR 5055 / iR5075 / iR5075N / iR5065N / iR5055N

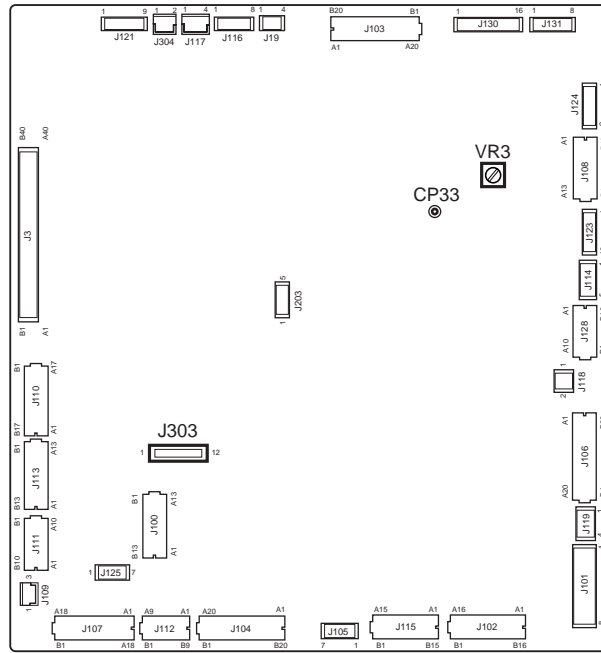

F-15-21

- J303  
When replacing the PCB, be sure to move the J303 shorting connector from the existing to new PCB.  
The control panel indications will fail to appear unless the shorting connector has been connected properly.
- CP33  
Use it when checking the potential system.
- VR3  
for factory use

**15.2.9.3 DC Power Supply PCB**

iR5065 / iR 5055 / iR5075 / iR5075N / iR5065N / iR5055N

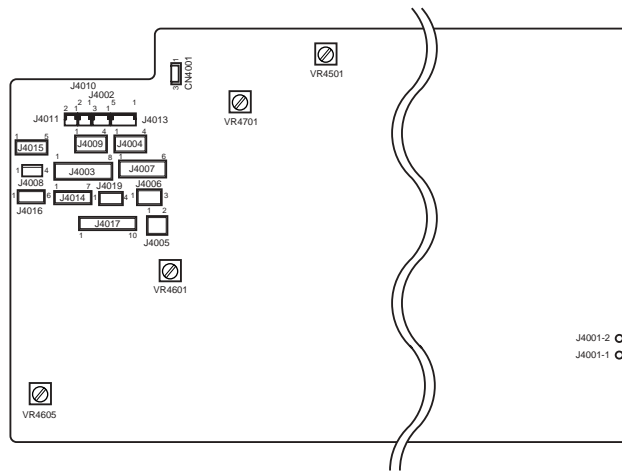

F-15-22

- VR4501, VR4601, VR4605, VR4701  
for factory use

**15.2.9.4 HVT PCB**

iR5065 / iR 5055 / iR5075 / iR5075N / iR5065N / iR5055N

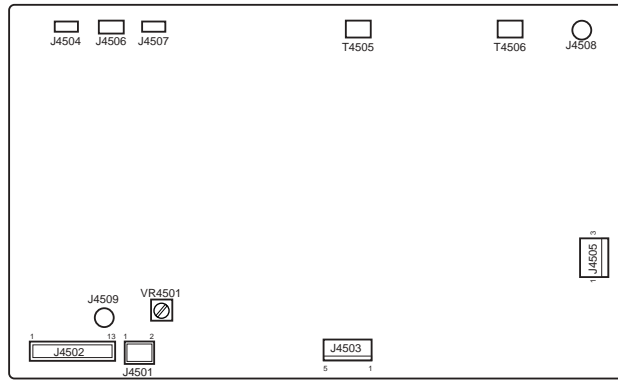

F-15-23

- VR4501  
for factory use





---

## Chapter 16 Self Diagnosis

---



---

# Contents

16.1 Error Code Table.....	16-1
16.1.1 Error Code.....	16-1
16.2 Error Code Details .....	16-2
16.2.1 Detail Error Code.....	16-2
16.2.2 E602 in Detail .....	16-16
16.3 Error Code (SEND).....	16-18
16.3.1 Results of Self-Diagnosis.....	16-18
16.3.2 Error Codes .....	16-19
16.4 Jam Code.....	16-24
16.4.1 Jam Code (machine proper).....	16-24
16.4.2 Jam Code (finisher-related).....	16-25
16.4.3 Jam Code (ADF-related).....	16-26
16.5 Alarm Code .....	16-27
16.5.1 Alarm Code .....	16-27



## 16.1 Error Code Table

### 16.1.1 Error Code

iR5065 / iR 5055 / iR5075 / iR5075N / iR5065N / iR5055N

T-16-1

Code	Description
E000	the heater fails to heat
E001	there is an abnormal rise in temperature
E002	there is an error in the rise in temperature
E003	there is an error in the rise in temperature
E004	there is an error in the IH power supply/IH control mechanism
E005	there is no fixing web/there is an error in the detection of web solenoid connection
E010	there is a feed motor error
E012	there is a drum motor error
E013	the collecting toner pipe is clogged
E014	there is a fixing motor error
E020	there is no toner in the developing assembly; there is an error in the detection of developing assembly toner sensor connection; there is an error in the detection of developing hopper toner sensor connection
E025	there is an error in the detection of toner feed motor over-current, there is an error in the detection of toner bottle motor over-current, there is an error in the detection of toner bottle motor connection
E032	the counter of the NE controller has malfunctioned
E061	there is a potential control error/there is an APC error
E100	there is a BD error
E102	there is a laser verify error
E110	there is a polygon motor error
E121	there is a controller cooling error
E193	there is a gate array error
E196	the EEPROM is faulty
E197	there is an error in communication between the DC controller PCB and the video PCB/an error in communication of the DC controller PCB
E225	Error in CIS Unit (DADF)
E240	there is an error in the communication between the main controller PCB and the DC controller PCB
E315	there is an image data error
E503	there is a finisher internal communication error (finisher)
E505	there is a backup memory error in the finisher (finisher)
E514	there is a trailing edge assist motor error (finisher)
E519	there is a gear change motor error (finisher)
E530	there is a front alignment error (finisher)
E531	there is a staple error (finisher)
E532	there is a stapler shift error (finisher)
E535	there is a swing error (finisher)
E537	there is a rear alignment error (finisher)
E540	there is an upper tray ascent/descent error (finisher)
E542	there is a lower tray ascent/descent error (finisher)
E584	there is a shutter unit error (finisher)
E590	there is a punch motor error (punch unit)
E591	there is a punch dust sensor error (punch unit)
E592	there is a punch horizontal registration sensor error (punch unit)
E593	there is a punch shift motor error (punch unit)
E5F0	there is a saddle paper positioning error
E5F1	there is a saddle paper folding error
E5F2	there is a saddle guide error
E5F3	there is a saddle alignment error
E5F4	there is a saddle rear staple error
E5F5	there is a saddle front staple error
E5F6	there is a saddle butting error
E5F9	there is a saddle switch error
E602	error in hard disk or HDD encryption board
E604	the image memory is faulty or inadequate
E609	the hard disk is faulty
E610	the HDD encryption key is faulty
E611	retried reboot due to SRAM crash and the like during the shutdown recovery job execution

Code	Description
E612	error in postponement
E674	There is a fault in the communication between the fax controller PCB (2-line) and the main controller PCB.
E710	there is a printer IPC error
E711	there is a printer IPC error
E713	there is a sorter IPC error
E717	the communication with the NE controller is faulty
E719	the coin vendor is faulty
E730	the PDL software is faulty
E732	there is a reader communication error
E733	the printer communication is faulty
E740	the Ethernet board is faulty
E744	the language file/boot ROM is faulty
E746	the accessories board type is wrong
E748	the controller board do not match
E804	there is a DC power supply fan error/there is an IH power supply cooling fan error
E805	there is a heat discharge fan error/there is a feed fan error
E808	there is a IH power supply input error
E821	the cleaner is clogged
E824	there is a primary charging cooling fan error
E840	there is a shutter error
E841	there is an error in the detection of fixing inlet guide solenoid connection

## 16.2 Error Code Details

### 16.2.1 Detail Error Code

iR5065 / iR 5055 / iR5075 / iR5075N / iR5065N / iR5055N

T-16-2

Code	Description	Remedy
<b>E000</b>	The heater fails to heat. After correcting the fault, be sure to reset the error. (COPIER>FUNCTION>CLEAR>ERR)	
0000	After power-on, the reading of the main thermistor does not increase to 70 deg C or higher within 20 sec.	- Replace the main/shutter thermistor. - Replace the DC controller PCB.
0010	The power has been turned off and then on without resetting the error.	- Reset the error. (COPIER>FUNCTION>CLEAR>ERR)
<b>E001</b>	There is an abnormal rise in temperature. After correcting the fault, be sure to reset the error. (COPIER>FUNCTION>CLEAR>ERR)	
0001	There is an error or an open circuit in the main thermistor, shutter thermistor, or sub thermistor.	- Check the connector of each thermistor for any fault in connection and wiring. - Replace the thermistor in question. - Replace the DC controller PCB.
0002	The reading of the main thermistor, shutter thermistor, or sub thermistor is 230 deg C or higher for 2 sec.	- Replace the thermistor in question. - Replace the DC controller PCB.
0003	The reading is not 150 deg C or higher or 210 deg C or lower within 30 sec.	-Check the connecting of the main/ sub/ shutter thermistors. -Check the mounting of the main/ sub/ shutter thermistors. -Exchange the main/ sub/ shutter thermistors. -Exchange the DC controller PCB.
0010	The power has been turned off and then back on without resetting the error.	- Reset the error. (COPIER>FUNCTION>CLEAR>ERR)
<b>E002</b>	There is an abnormal rise in temperature. After correcting the fault, be sure to reset the error. (COPIER>FUNCTION>CLEAR>ERR)	

Code	Description	Remedy
0000	The reading of the main thermistor is not 100 deg C 12 sec after it has exceeded 70 deg C.	- Check the connector of the main/shutter thermistor for any fault in connection and wiring. - Check the main/shutter thermistor for mounting condition. - Replace the main/shutter thermistor. - Replace the fixing heater unit.
0001	The reading of the main thermistor is not 150 deg C 15 sec after it has exceeded 100 deg C.	- Replace the DC controller PCB.
0010	The power has been turned off and then back on without resetting the error.	- Reset the error. (COPIER>FUNCTION>CLEAR>ERR)
<b>E003</b>	There is an abnormal rise in temperature. After correcting the fault, be sure to reset the error. (COPIER>FUNCTION>CLEAR>ERR)	
0000	The reading of the main thermistor is lower than 70 deg C for 2 sec or more after it has exceeded 100 deg C.	- Check the connector of the main/shutter thermistor for any fault in connection and wiring. - Check the main/shutter thermistor for mounting condition. - Replace the main/shutter thermistor. - Replace the fixing heater unit. - Replace the DC controller PCB.
0010	The power has been turned off and then back on without resetting the error.	- Reset the error. (COPIER>FUNCTION>CLEAR>ERR)
<b>E004</b>	The IH power supply is faulty/the IH control mechanism is faulty. After correcting the fault, be sure to reset the error. (COPIER>FUNCTION>CLEAR>ERR)	
0010	The power has been turned off and then back on without resetting the error.	- Reset the error. (COPIER>FUNCTION>CLEAR>ERR)
0101	There is a mismatch between the input voltage and the IH power supply ID.	Replace the fixing heater power supply with one designed for the country of installation (voltage).
0102	The IH current is faulty. (current leakage)	- Check the connector for any fault in connection. - Replace the fixing heater power supply. - Replace the DC controller PCB.
0103	The IH current is faulty. (no current)	
0104	There is an IH over-current.	
0105	The IH input voltage is too high.	
0106	The IH input voltage is too low.	
0201	At power-on (or, when IH is at reset), the IH control mechanism is not in an initial state.	
0202	At IH start-up, the IH control enable flag is not set within 1 sec after the start flag is set.	- Replace the DC controller PCB.
0203	With IH at rest, the IH control flag is not released.	
0204	The 12-V power supply (IH relay) is identified as being off.	
0205	At IH start-up, the PWM/ON data is faulty ('0' or 'FFFF')	
<b>E005</b>	There is no fixing web/there is an error in the detection of web solenoid connection.	
0000	The absence of the fixing web has been detected for 5 sec or more.	- Replace the fixing web. - Replace the fixing web length sensor. - Replace the DC controller PCB. After correcting the fault, be sure to reset the fixing web counter reading. (COPIER>COUNTER>MISC>FIX-WEB)
0001	At power-on, the connection of the web solenoid is not detected.	- Check the connector for any fault in connection. - Replace the solenoid.
0010	The power has been turned off and then back on without resetting the error.	- Reset the fixing web counter. (COPIER>COUNTER>MISC>FIX-WEB)
<b>E010</b>	There is a feed motor error.	
0000	The FG signal of the feed motor does not arrive for 2 sec or more even when the feed motor has been turned on.	- Check the connector for any fault in connection. - Replace the motor
<b>E012</b>	There is a drum motor error.	
0000	The FG signal of the drum motor does not arrive for 2 sec or more even when the drum motor has been turned on.	- Check the connector for any fault in connection. - Replace the motor.

Code	Description	Remedy
<b>E013</b>	The waste toner pipe is clogged.	
0000	The waste toner pipe is identified as being clogged for 4 sec or more.	<ul style="list-style-type: none"> <li>- Check the connector for any fault in connection.</li> <li>- Replace the waste toner feedscrew lock detecting switch.</li> <li>- Replace the waste toner feed unit.</li> <li>- Replace the DC controller PCB.</li> </ul>
0010	The power has been turned off and then back on without resetting the error.	
<b>E014</b>	There is a fixing motor error.	
0000	The Phase lock signal of the fixing motor does not arrive for 2 sec even when the fixing motor has been turned on.	<ul style="list-style-type: none"> <li>- Check the connector for any fault in connection.</li> <li>- Replace the motor.</li> </ul>
<b>E020</b>	There is no toner in the developing assembly; there is an error in the detection of developing toner sensor connection; there is an error in the detection of hopper toner sensor connection	
0000	The presence of toner is detected inside the sub hopper and, in addition, the absence of toner is detected inside developing assembly for 120 sec continuously even when operation has been under way for the supply of toner to the developing assembly.	<ul style="list-style-type: none"> <li>- Check the connector of the developing toner sensor for any fault in connection.</li> <li>- Replace the developing toner sensor.</li> <li>- Replace the hopper toner sensor.</li> </ul>
0001	At power-on, the connection of the developing assembly toner sensor is not detected.	<ul style="list-style-type: none"> <li>- Check the connector for any fault in connection.</li> <li>- Replace the sensor.</li> </ul>
0002	At power-on, the connection of the developing hopper toner sensor is not detected.	<ul style="list-style-type: none"> <li>- Check the connector for any fault in connection.</li> <li>- Replace the sensor.</li> </ul>
<b>E025</b>	There is a toner feed motor over-current detection error, there is a toner bottle motor connection detection error.	
0001	An over-current has been detected in the toner feed motor.	<ul style="list-style-type: none"> <li>- Check the connector for any fault in connection.</li> <li>- Replace the motor.</li> </ul>
0002	An over-current has been detected in the toner bottle motor.	<ul style="list-style-type: none"> <li>- Check the connector for any fault in connection.</li> <li>- Replace the motor.</li> </ul>
0003	At power-on, the connection of the toner bottle motor is not detected.	<ul style="list-style-type: none"> <li>- Check the connector for any fault in connection.</li> <li>- Replace the motor.</li> </ul>
<b>E032</b>	The NE controller counter has malfunctioned.	
0001	An open circuit has been detected for the count pulse signal.	Turn off the main power, and check for an open circuit in the cable; then, turn the main power back on.
<b>E061</b>	There is a potential control error/there is an APC error.	
0001	As a result of potential control, the drum surface potential (VL2) of the background is 200 V or higher (i.e., causing a solid black image).	<ul style="list-style-type: none"> <li>- Replace the potential sensor unit.</li> <li>- Replace the laser scanner unit.</li> <li>- Replace the DC controller PCB.</li> </ul>
0002	The primary charging output used at time of printer output and the drum surface potential after laser output is identified as being 200 V or more (i.e., causing a solid black image).	
<b>E100</b>	There is a BD error.	
0001	A check is made of VLOCK at intervals of 100 msec while the laser is on. An error will be identified if it is not detected 10 times in sequence.	<ul style="list-style-type: none"> <li>- Replace the laser scanner unit.</li> <li>- Replace the DC controller PCB.</li> </ul>
<b>E102</b>	There is a laser verify error.	
0001	The machine model ID that has been read from the laser scanner EEPROM is not correct.	
<b>E110</b>	There is a polygon motor error.	



Code	Description	Remedy
0001	- Although the polygon motor has been turned on, VLOCK is not detected at all within 76.5 sec. - At time of a shift from full-speed to half-speed control, VLOCK is not detected at all for 7.5 sec. - At time of half-speed control, a check is made of VLOCK at intervals of 100 msec. An error will be identified if it is not detected 10 times continuously.	- Replace the laser scanner unit. - Replace the DC controller PCB.
<b>E121</b>	There is a controller cooling fan error.	
0001	Even though the controller cooling fan has been turned on, the controller cooling fan stop signal has been detected for 5 sec or more.	- Check the connector for any fault in connection. - Replace the fan.
<b>E193</b>	There is a gate array error.	
0001	The add-on through setting of the IMG1 cannot correctly be done (it is not correctly set 10 continuous times)	
<b>E196</b>	The EEPROM is faulty.	
1abb	There is a mismatch between the data that has been written in EEPROM and the data that has been read. (a: chip No. 0 through 5; bb: chip faulty address)	- Initialize the RAM. - Replace the EEPROM. - Replace the DC controller PCB.
2abb	The ID in EEPROM that has been read and the ID in ROM are compared. An error will be identified if they do not match. (a: chip No. 0 through 5; bb: chip faulty address)	
3abb	When the main power is turned on, the ID in EEPROM and the ID in ROM are compared. An error will be identified if they do not match. (a: chip No. 0 through 5; bb: chip faulty address)	- Check the position and condition of the EEPROM. - Initialize the RAM. - Replace the EEPROM. - Replace the DC controller PCB.
<b>E197</b>	There is an error in communication between the DC controller PCB and the video PCB/an error in communication of the DC controller PCB.	
0000	An error in the communication between the DC controller PCB and the video PCB has occurred.	
0001	An error in the communication with the laser driver module of the DC controller PCB has occurred.	
<b>E225</b>	Error in CIS Unit (DADF)	
1010	- The error is cleared by turning off/on the power switch. This triggers function-restricted mode. - CIS unit suspends its functions; only CCD unit performs duplexing reading. - Functions will be automatically restored by replacing CIS unit.	
<b>E240</b>	The communication between the main controller PCB and the DC controller PCB is faulty.	
0000	There is an error in the communication between the main controller PCB and the CPU of the DC controller PCB.	- Check the connector for any fault in connection. - Replace the DC controller PCB. - Replace the main controller PCB.
<b>E248</b>	Error in EEPROM on ADF controller PCB	
0001	Error appears when turning ON the EEPROM for reader controller PCB	- Replacement of reader controller PCB - Replacement of ADF controller PCB
0002	Error appears when writing in EEPROM for reader controller PCB.	
0003	Error appears when reading from EEPROM for reader controller PCB.	
0101	Error appears when turning ON the EEPROM for ADF controller PCB.	
0102	Error appears when writing in the EEPROM for ADF controller PCB.	
0103	Error appears when reading from the EEPROM for ADF controller PCB.	
<b>E315</b>	There is a fault in the image data.	
0007	There is a JIBIG encode error.	- Turn off and then back on the power.
000d	There is a JBIG decode error.	
0200	CRC error detected in OpenI/F (image transfer from the external controller); retried but failed to restore.	- Replace the external controller connection PCB

Code	Description	Remedy
0300	Cubic timeout	- Turn off/on the power switch. Replace the PCB for frequent error occurrence.
0400	Shift device A timeout	
0401	Shift device B timeout	
<b>E503</b>	There is an error in the finisher internal communication (finisher).	
0002	There is an error in the communication between the finisher and the saddle unit.	- Check the connection between the saddle stitcher controller PCB and the finisher controller PCB.
0003	There is an error in the communication between the finisher and the punch unit.	- Check the communication between the saddle stitcher controller PCB and the finisher controller PCB.
<b>E505</b>	There is a finisher backup memory error (finisher).	
0001	An error has occurred in the data stored in the backup memory.	- Turn off the main power; check the DC controller PCB and the finisher controller PCB for wiring; check the 24-V system fuse; then, turn the main power back on.
0002	There is an error in the punch unit EEPROM data.	- Turn off the main power; check the DC controller PCB and the puncher controller PCB for wiring; then, check the 24-V system fuse; then, turn the main power back on.
<b>E514</b>	There is a trailing edge assist motor error (finisher).	
8001	The home position sensor does not go off even when the trailing edge assist motor has rotated for a specific period of time.	<ol style="list-style-type: none"> <li>1. Check the trailing edge assist home position sensor. Is the sensor normal?</li> <li>2. Check the wiring between the finisher controller PCB and the trailing edge assist motor. Is it normal?</li> <li>3. Check the trailing edge assist mechanism. Is there a fault?</li> <li>4. Try replacing the trailing edge assist motor. Is the problem corrected?</li> </ol>
8002	The home position sensor does not go on even when the trailing edge assist motor has rotated for a specific period of time.	
<b>E519</b>	There is a gear change motor error (finisher).	
8001	The home position sensor does not go off even when the gear change motor has rotated for a specific period of time.	<ol style="list-style-type: none"> <li>1. Check the gear change home position sensor. Is the sensor normal?</li> <li>2. Check the wiring between the finisher controller PCB and the change motor. Is it normal?</li> <li>3. Check the gear change mechanism. Is there a fault?</li> <li>4. Try changing the gear change motor. Is the problem corrected?</li> </ol>
0002	The home position sensor does not go on even when the gear change motor has rotated for a specific period of time.	
<b>E530</b>	There is a front alignment error. (finisher)	

Code	Description	Remedy
8001	The home position sensor does not go off even when the front alignment motor has rotated for a specific period of time.	<ol style="list-style-type: none"> <li>1. Check the aligning plate home position sensor. Is it normal?</li> <li>2. Check the wiring between the finisher controller PCB and the aligning plate front motor. Is it normal?</li> <li>3. Is there any mechanical obstacle in the path in which the aligning plate moves?</li> <li>4. Try replacing the aligning plate front motor. Is the problem corrected?</li> </ol>
8002	The home position sensor does not go on even when the front alignment motor has rotated for a specific period of time.	
<b>E531</b>	There is a stapling error. (finisher)	
0001	The home position sensor does not go off even when the stapler motor has rotated for a specific period of time.	<ol style="list-style-type: none"> <li>1. Check the wiring between the finisher controller PCB and the stapler. Is it normal?</li> <li>2. Try replacing the stapler. Is the problem corrected?</li> </ol>
0002	The home position sensor does not go on even when the stapler motor has rotated for a specific period time.	
<b>E532</b>	There is a stapler shift error. (finisher)	
8001	The home position sensor does not go off even when the stapler shift motor has rotated for a specific period of time.	<ol style="list-style-type: none"> <li>1. Check the stapler shift home position sensor. Is the sensor normal?</li> <li>2. Check the wiring between the finisher controller PCB and the stapler shift motor. Is it normal?</li> <li>3. Is there any mechanical obstacle in the path of the stapler shift base?</li> <li>4. Try replacing the stapler shift motor. Is the problem corrected?</li> </ol>
8002	The home position sensor does not go on even when the stapler shift motor has rotated for a specific period of time.	
<b>E535</b>	There is a swing error. (finisher)	
8001	The home position sensor does not go off even when the swing motor has rotated for a specific period of time.	<ol style="list-style-type: none"> <li>1. Check the swing home position sensor. Is it normal?</li> <li>2. Check the wiring between the finisher controller PCB and the swing motor. Is it normal?</li> <li>3. Is there a fault in the swing mechanism?</li> <li>4. Try replacing the swing motor. Is the problem corrected?</li> </ol>
8002	The home position sensor does not go on even when the swing motor has rotated for a specific period of time.	
<b>E537</b>	There is a rear alignment error. (finisher)	

Code	Description	Remedy
8001	The home position sensor does not go off even when the swing motor has rotated for a specific period of time.	1. Check the aligning plate rear home position sensor. Is it normal? 2. Check the wiring between the finisher controller PCB and the aligning plate rear motor. Is it normal? 3. Is there a mechanical obstacle in the path of the aligning plate? 4. Try replacing the aligning plate rear motor. Is the problem corrected?
8002	The home position sensor does not go on even when the swing motor has rotated for a specific period of time.	
<b>E540</b>	There is an upper tray ascent/descent error. (finisher)	
8001	- If the tray does not return to home position when the tray 1 shift motor is driven for 20 seconds. - If the tray does not move to other area when tray 1 shift motor is driven for 4 seconds.	1. Check the No. 1 tray area sensors 1 through 3. Are they normal? 2. Check the wiring between the finisher controller PCB and the No. 1 tray shift motor. Is it normal? 3. Is there a fault in the tray ascent/descent mechanism? 4. Try replacing the No. 1 tray shift motor. Is the problem corrected?
8002	- The dangerous area is reached before the tray 1 paper surface sensor detects paper surface during the paper surface detection operation. - A discontinuous area is detected during tray operation.	
8003	The tray 1 closing detect switch is activated while the tray 1 is operating.	
8004	Clock signal input cannot be detected when the tray 1 shift motor has been driven for 0.2 second.	
8005	The lock detection signal turns OFF 150 ms after the lock detection signal turned ON.	
8006	The lock detection signal does not turn ON when the tray 1 shift motor has been driven for 1 second.	
8007	The lock detection signal does not turn OFF when the tray 1 shift motor is at a stop.	
<b>E542</b>	There is a lower tray ascent/descent error. (finisher)	
8001	There is a fault in the lower tray ascent/descent motor clock signal.	1. Check the No. 2 tray area sensors 1 through 3. Are the sensors normal? 2. Check the wiring between the finisher controller PCB and the No. 2 tray shift motor. Is it normal? 3. Is there a fault in the tray ascent/descent mechanism? 4. Try replacing the No. 2 tray shift motor. Is the problem corrected?
8002	There is an area error.	
0003	The safety switch has activated.	
<b>E584</b>	There is a shutter unit error. (finisher)	
8001	The shutter open sensor fails to go off. (The shutter does not close.)	1. Check the shutter home position sensor. Is it normal? 2. Check the wiring between the finisher controller PCB and the stack feeding motor and between the finisher controller PCB and the shutter open/close clutch. Is it normal? 3. Is there a fault in the shutter mechanism? 4. Try replacing the stack edging motor and the shutter open/close clutch. Is the problem corrected?
0002	The shutter open sensor does not go on. (The shutter does not open.)	
<b>E590</b>	There is a punch motor error. (punch unit)	

Code	Description	Remedy
8001	The punch home position sensor is not detected even when the punch motor has been driven for 200 msec.	- Check the punch home position sensor, horizontal registration motor, and punch driver PCB; thereafter, turn off and then back on the main power.
8002	The puncher does not detect the punch home position sensor while the motor is at rest at time of punch motor initialization.	
<b>E591</b>	There is a punch dust sensor error. (punch unit)	
8001	The incoming light voltage is faulty in the presence of light.	- Turn off and then back on the main power.
8002	The incoming light voltage is faulty in the absence of light.	
<b>E592</b>	There is a punch horizontal registration sensor error. (punch unit)	
8001	The incoming light voltage is faulty in the presence of light. (trailing edge sensor)	- turn off and then back on the main power.
8002	The incoming light is faulty in the absence of light and voltage. (trailing edge sensor)	
8003	The incoming light voltage is faulty in the presence of light. (horizontal registration sensor 1)	
8004	The incoming light voltage is faulty in the absence of light. (horizontal registration sensor 1)	
8005	The incoming light voltage is faulty in the presence of light. (horizontal registration sensor 2)	
8006	The incoming light voltage is faulty in the absence of light. (horizontal registration sensor 2)	
8007	The incoming light voltage is faulty in the presence of light. (horizontal registration sensor 3)	
8008	The incoming light voltage is faulty in the absence of light. (horizontal registration sensor 3)	
8009	The incoming light voltage is faulty in the presence of light. (horizontal registration sensor 4)	
800A	The incoming light voltage is faulty in the absence of light. (horizontal registration sensor 4)	
<b>E593</b>	There is a punch shift motor error. (punch unit)	
8001	In the presence of light, the incoming light voltage HP sensor does not go off.	- Turn off and the back on the main power.
8002	In the absence of light, the incoming light voltage HP sensor does not go on.	
<b>E5F0</b>	There is a saddle paper positioning error.	
0001	The paper positioning plate home position sensor does not go on even when the paper positioning plate motor has been driven for 1.33 sec. paper positioning plate motor (M4S), paper positioning plate home position sensor (PI7S)	- Check the paper positioning plate motor (M4S) and the paper positioning plate home position sensor (PI7S).
0002	The paper positioning plate home position sensor does not go off even when the paper positioning plate motor has been driven for 1 sec. paper positioning plate motor (M4S), paper positioning plate home position sensor (PI7S)	
<b>E5F1</b>	There is a saddle paper folding error.	

Code	Description	Remedy
0001	The number of detection pulses of the paper folding motor clock sensor is lower than a specific value. paper folding motor (M2S), paper folding motor clock sensor (PI4S)	- Check the paper folding motor (M2S) and the paper folding motor clock sensor (PI4S).
0002	The state of the paper folding home position sensor does not change even when the paper folding motor has been driven for 3 sec. paper folding motor (M2S), paper folding motor clock sensor (PI4S)	
<b>E5F2</b>	There is a saddle guide error.	
0001	The guide home position sensor does not go on even when the guide motor has been driven for 0.455 sec. guide motor (M3S), guide home position sensor (PI13S)	- Check the guide motor (M3S) and the guide home position sensor (PI13S).
0002	The guide home position sensor does not go off even when the guide motor has been driven for 1 sec. guide motor (M3S), guide home position sensor (PI13S)	
<b>E5F3</b>	There is a saddle alignment error.	
0001	The aligning plate home position sensor does not go on even when the aligning motor has been driven for 0.5 sec. (if at time of initialization, 1.67 sec) alignment motor (M5S), aligning plate home position sensor (PI5S)	- Check the alignment motor (M5S) and the aligning plate home position sensor (PI5S).
0002	The aligning plate home position sensor does not go off even when the aligning motor has been driven for 1 sec. alignment motor (M5S), aligning plate home position sensor (PI5S)	
<b>E5F4</b>	There is a saddle rear stapler error.	
0001	The stitching home position sensor does not go on even when the stitching motor (rear) has been driven in reverse for 0.5 sec or more. stitching motor (rear, M6S), stitching home position sensor (rear, MS5S)	- Check the stitching motor (rear, M6S) and the stitching home position sensor (rear, MS5S).
0002	the stitching home position sensor does not go off even when the stitching motor (rear) has been driven in normal direction for 0.5 sec or more. stitching motor (rear, M6S), stitching home position sensor (rear, MS5S)	
<b>E5F5</b>	There is a saddle front stapling error.	
0001	The stitching home position sensor does not go on even when the stitching motor (front) has been driven in reverse for 0.5 sec or more. stitching motor (front, M7S), stitching home position sensor (front, MS7S)	- Check the stitching motor (front, M7S) and the stitching home position sensor (front, MS7S).
0002	The stitching home position sensor does not go off even when the stitching motor (front) has been driven in normal direction for 0.5 sec or more. stitching motor (front, M7S), stitching home position sensor (front, MS7S)	
<b>E5F6</b>	There is a saddle butting error.	

Code	Description	Remedy
8001	The paper pushing plate home position sensor does not go on even when the paper pushing plate motor has been driven for 0.3 sec or more. paper pushing plate motor (M8S), paper pushing plate home position sensor (PI14S)	- Check the paper pushing plate motor (M8S) and the paper pushing plate home position sensor (PI14S).
8002	The paper pushing plate home position sensor does not go off even when the paper pushing plate motor has been driven for 80 msec. paper pushing plate motor (M8S), paper pushing plate home position sensor (PI14S)	
8003	The number of detection pulses of the paper pushing plate motor clock sensor is lower than a specific value. paper pushing plate motor (M8S), paper pushing plate motor clock sensor (PI1S)	- Check the paper pushing plate motor (M8S) and the paper pushing plate motor clock sensor (PI1S).
8004	The paper pushing plate leading edge sensor does not go off even when the paper pushing plate motor has been driven for 80 msec. paper pushing plate motor (M8S), paper pushing plate leading edge position sensor (PI15S)	- Check the paper pushing plate motor (M8S) and the paper pushing plate leading edge position sensor (PI15S).
8005	The paper pushing plate leading edge position sensor does not go on even when the paper pushing plate has been driven for 0.3 sec or more. paper pushing plate motor (M8S), paper pushing plate leading edge position sensor (PI15S)	
<b>E5F9</b>	There is a saddle switch error.	
0001	With any of the sensor identifying its respective cover as being closed, the inlet cover switch is identified as being open for 1 sec from the start of initial rotation or printing: - inlet cover sensor (PI9S) - front cover open/closed sensor (PI2S) - delivery cover sensor (PI3S) Or, the front cover switch (MS2S) or the delivery cover switch (MS3S) is open. inlet cover switch (MS1S), front cover switch (MS2S), delivery cover switch (MS3S)	- Check the inlet cover switch (MS1S), front cover switch (MS2S), and the delivery cover switch (MS3S).
0002	With any of the following sensors identifying its respective cover as being closed, the front cover switch is identified as being open for 1 sec or more after the start of initial rotation or printing. - inlet cover sensor (PI9S) - front cover open/closed sensor (PI2S) - delivery cover sensor (PI3S) - front cover switch (MS2S), delivery cover switch (MS3S)	- Check the front cover switch (MS2S) and the delivery cover switch (MS3S).
0003	With any of the following sensors identifying its respective cover as being closed, the delivery cover switch is identified as being open for 1 sec or more from the start of initial rotation or printing: - inlet cover sensor (PI9S) - front cover open/closed sensor (PI2S) - delivery cover sensor (PI3S) - delivery cover switch (MS3S)	- Check the delivery cover switch (MS3S).
<b>E602</b>	error in hard disk or HDD encryption board	

Code	Description	Remedy
0001	[Cause] HD detection error: the HD cannot be detected; the machine fails to turn ready; an error state is returned. [Description] at time of Bootrom processing, BARSAC is started up and mounted (usrIde). [Timing] once at power-on	- See details for E602.
0002	[Cause] start-up file absent: the main CPU program does not exist on the HD (/BOOTDEV/BOOT/and lower). [Description] at time of Bootrom processing, when the system files are being loaded (usrIde). [Timing] once at start-up	- See details for E602.
0003	[Cause] HD write abort error: /BOOTDEV sector on the HD cannot be read. [Description] BARSAC (all areas at Bootable start-up) [Timing] once at start-up	- See details for E602.
0006	[Cause] SubBootable compatible with the PDL type does not exist in /BOOTDEV/BOOT. [Description] when SubBoot in oclibroot is being loaded [Timing] once at start-up of Bootable	- See details for E602.
0007	[Cause] ICC-Profile compatible with the PDL type does not exist in /BOOTDEV/PDL. [Description] beginning of oclibroot; the PDL team function is called and determined [Timing] once at start-up of Bootable	- See details for E602.
2000	error in the authentication between the host machine and the encryption board	- Check the encryption board connection, plug off/in the connector and turn off/on the power switch. - Perform the key-clear.
2001	error in alignment of the encryption board operation	- Perform the key-clear.
2002	the encryption board failure, etc.	- Check the encryption board connection, plug off/in the connector and turn off/on the power switch. - Perform the key-clear. - Replace the encryption board and reinstall the HDD format and SYSTEM of SST - Replace LAN-BARSAC board -> replace the main board
01XX	/FSTDEV is faulty.	- See details for E602.
02XX	/IMG_MNG is faulty.	- See details for E602.
03XX	/FSTCDEV is faulty.	- See details for E602.
04XX	/APL_GEN is faulty.	- See details for E602.
05XX	/TMP_GEN is faulty.	- See details for E602.
06XX	/TMP_FAX is faulty.	- See details for E602.
07XX	/TMP_PSS is faulty.	- See details for E602.
08XX	/PDLDEV is faulty.	- See details for E602.
09XX	/BOOTDEV is faulty.	- See details for E602.
10XX	/APL_MEAP is faulty.	- See details for E602.
11XX	/APL_SEND is faulty.	- See details for E602.
12XX	/APL_KEEP is faulty.	- See details for E602.
13XX	/APL_LOG is faulty.	- See details for E602.
FFXX	There is an error in a partition that cannot be identified.	- See details for E602.
<b>E604</b>	The image memory is faulty or inadequate.	
0000	The memory is inadequate for the model.	- Add memory.
<b>E609</b>	The hard disk is faulty.	
0008	At time of start-up, the HDD fails to reach a specific temperature within a specific period of time.	- Replace the hard disk. - Replace the DC controller PCB.
0009	At time of a sleep shift, the temperature is below a specific level.	
<b>E610</b>	The HDD encryption key is faulty. (hardware composition error, initialization error, ID key error, ID processing error)	



Code	Description	Remedy
0001	There is no encryption board.	- Check the hardware composition.
0002	The memory configuration is inadequate for the use of encryption.	
0101	The attempt to initialize the memory used for storage of the key has failed.	- Turn off and then on the main power.
0102	The attempt to initialize the encryption processing area has failed.	
0201	There is an error in the encryption processing area.	
0202	There is an error in the encryption processing area.	
0301	The attempt to create an ID key has failed.	
0302	A fault has been detected in the encryption key.	
0303	A fault has been detected in the encryption key.	
0401	An error has been detected at time of coding.	- Turn off and then on the main power.
0402	An error has been detected at time of decoding.	
0501	error in the document management information on /FSTDEV	
<b>E611</b>	retried reboot due to SRAM crash and the like during the shutdown recovery job execution	
0000	SRAM data were broken and the stored job information cannot be read; this causes the repeated reboot trials to recover the power shutdown, and thus the redundant job transmission. This phenomenon triggers E code.	Clear SRAM to cancel the shutdown recovery job.
<b>E612</b>	error in postponement Timing: when starting the host machine	
0000	other errors Unlikely errors except the errors shown below Write the correct license and new serial numbers and turn off/on the power switch.	Write the correct license and new serial numbers and turn off/on the power switch.
0001	error in the license checksum Unmatched license checksum	
0002	error in the machine code Different machines are specified by the old and new machine codes, respectively.	
0003	error in the new serial number No data is entered in the new serial number field	
0004	error in old serial numbers The license serial number is unmatched with SoftID	
0005	error in postponement The license is written although postponement has already been performed once.	- Turn off and then on the main power.
<b>E674</b>	There is a fault in the communication between the fax controller PCB (2-line) and the main controller PCB.	
0001	An attempt to set fax device mode has failed.	- Check the connection of the cable between the fax controller PCB (2-line) and the main controller PCB. - Replace the ROM DIMM of the fax controller PCB (2-line). - Replace the fax controller PCB (2-line). - Replace the main controller PCB.
<b>E710</b>	There is a fault in IPC initialization.	
0001	At time of power-on, the communications IC on the main controller PCB does not become ready within 3 sec after start-up.	- Check the connection of the cable.
0002	At power-on, the machine communication IC has detected an error.	
<b>E711</b>	There is a fault in the IPC communication.	

Code	Description	Remedy
0001	After power-on, the occurrence of an error has been written 4 times in 1.5 sec to the error register of the communications IC on the main controller PCB.	- Check the connection of the cable.
0002	After power-on, the machine communication IC has detected an error.	
<b>E713</b>	There is a sorter IPC error.	
0000	An error has been detected in the sorter communication IC.	- Check the connection of the cable. - Replace the finisher controller PCB. - Replace the DC controller PCB.
<b>E717</b>	There is a fault in the communication with the NE controller. After correcting the fault, be sure to reset the error. (COPIER>FUNCTION>CLEAR>ERR)	
0001	An error has occurred at time of NE controller start-up. The NE controller that was connected before power-off is not connected at power-on.	- Check the connection of the cable.
0002	There is an IP error while the NE controller is in operation. The IPC may have an open circuit or the IPC communication cannot be recovered.	
<b>E719</b>	There is a fault in the coin vendor. After correcting the fault, be sure to reset the error. (COPIER>FUNCTION>CLEAR>ERR)	
0001	An error has occurred at time of coin vendor start-up. The coin vendor was connected before power-off, but is not connected at power-on.	- Check the connector of the cable.
0002	An IPC error has occurred while the coin vendor is in operation. The IPC may have an open circuit, or the IPC communication cannot be recovered. The pickup/delivery signal line has an open circuit. An illegal connection has been detected.	
0003	While a unit price is being obtained at start-up, an error has occurred in the communication with the coin vendor.	
0011	An error has occurred at card reader start-up. The card reader that was connected before power-off is not connected at power-on.	
0012	An IPC error has occurred while the card reader is in operation. The IPC may have an open circuit, or the IPC communication cannot be recovered.	
<b>E730</b>	There is a fault in the PDL software.	
1001	There is an initialization error.	- Execute PDL resetting. - Turn off and then on the main power.
100A	An error has occurred that can be fatal to the system (e.g., initialization error).	
9004	There is a fault in the PAI communication with an outside controller.	- Turn off and then back on the main power. - Check the open I/F board and cable connection.
9005	There is a fault in video connection with an external controller.	- Replace the external controller open I/F board. - Replace the main controller PCB.
A006	absence of PDL response: there is no PDL response because of a fault in or the absence of Subbootable.	- Execute PDL resetting. - Turn off and then on the main power. - Check the connection of the SURF board. - Re-install the firmware. - Replace the main controller PCB.
A007	There is a mismatch in version between the machine control software and the PDL control software.	- Execute PDL resetting. - Turn off and then on the main power. - Execute full formatting and install the system software.
B013	The font data is corrupted.	- Turn off and then on the main power. - Re-install the system software. - Execute full formatting and install the system software.
<b>E732</b>	error in reader communication	
0001	There is a communication error between the reader and main controller (DDI-S communication error), or between the reader and the charger unit.	- Check the communication between the reader unit and the main controller. - Check the power supply of the reader unit. (Check to see if initialization takes place at start-up.) - Replace the reader controller PCB, reader relay PCB, or main controller PCB. - Check the connection of the charger unit. (iR5075/5075N only.)
8888	error in difference of scanner	- check the scanner model - in service mode, select: COPIER > OPTION > BODY > SCANTYPE to check
<b>E733</b>	There is a fault in the printer communication.	

Code	Description	Remedy
0000	The attempt at communication with the printer fails at start-up.	- Check the connection of the cable between the DC controller and the main controller.
0001	There is a DDI-P communication error.	- Check the power supply of the printer. (Check to see if initialization takes place at start-up.)
0010	DDI-P communication error DC controller cannot detect Vsync signal even after 2 minutes elapsed from register setting completed in the controller.	- Replace the DC controller PCB or the main controller PCB.
<b>E740</b>	There is a fault in the Ethernet board.	
0002	The MAC address is illegal.	- Replace the main controller PCB.
<b>E744</b>	There is a fault in the language file/boot ROM.	
0001	There is a mismatch between the language version on the HDD and the version of Bootable.	- Download the language file of the correct version.
0002	The size of the language file on the HDD is too big.	
0003	There is no language file that is described in CONfig.txt on the HDD.	
0004	A switchover to a language file on the HDD cannot be made.	
1000	The boot ROM in question is one designed for a different model.	- Replace the boot ROM with one of the appropriate version.
2000	The engine ID is illegal.	- Turn off and then on the main power.
<b>E746</b>	There is an error caused by a mismatch of the accessories board.	
0003	At start-up, a UFR board for a different model has been detected.	- Replace the UFR board with one for the model in question.
<b>E748</b>	error in controller board	
4910	error in detection of the controller plate differs from the equipment	- Replace the main controller PCB.
<b>E804</b>	There is a DC power supply fan error/there is an IH power supply cooling fan error.	
0000	The DC power supply fan stop signal has been detected for 5 sec or more even when the DC power fan is on.	- Check the connection of the connector. - Replace the fan.
0001	The IH power supply cooling fan stop signal has been detected for 5 sec or more even when the IH power supply cooling fan is on.	- Check the connection of the connector. - Replace the fan.
0002	The accessories power supply cooling fan stop signal has been detected for 5 sec or more even when the accessories power supply cooling fan is on.	- Check the connection of the connector. - Replace the fan.
<b>E805</b>	There is a heat discharge fan error/there is a feed fan error.	
0001	The heat discharge fan stop signal has been detected for 5 sec or more even when the heat discharge fan is on.	- Check the connection of the connector. - Replace the fan.
0002	The feed fan stop signal has been detected for 5 sec even when the feed fan is on.	- Check the connection of the connector. - Replace the fan.
<b>E808</b>	IH power supply input error	
0001	The IH power supply input voltages are higher than the stipulated voltages	- Connect with the outlet of a correct voltage. - Check the connection of the connector. - Replace the fixing heater power supply.
0002	The IH power supply input voltages are lower than the stipulated voltages	
<b>E821</b>	There is a cleaner clogging error.	
0001	Clogging of toner inside the cleaner has been detected with reference to an abnormal rise in the cleaner thermistor.	- Remove the collecting toner from inside the cleaner. - Replace the air filter of the heat discharge fan.
<b>E824</b>	There is a primary charging cooling fan error.	
0001	The primary charging cooling fan stop signal has been detected for 5 sec or more even when the primary charging cooling fan is on.	- Check the connection of the connector. - Replace the fan.
<b>E840</b>	There is a shutter error.	

Code	Description	Remedy
0001	While the shutter is in operation, the sensor signal is not detected and, in addition, it is still not detected after 3 retries.	- Check the connection of the connector of the shutter motor and the shutter HP sensor. - check the mounting of the pin used to match the shutter gear phase of the fixing unit (See descriptions under "Points to Note When Mounting the Fixing Roller.")
0002	The interval of ON-OFF detection by the sensor in response to shutter operation is shorter than a specific time period.	- Replace the shutter HP sensor and the shutter motor.
<b>E841</b>	There is an error in the detection of fixing inlet guide connection.	
0001	At power-on, the connection of the fixing inlet guide solenoid is not detected.	- Check the connection of the connector. - Replace the solenoid.

### 16.2.2 E602 in Detail

iR5065 / iR 5055 / iR5075 / iR5075N / iR5065N / iR5055N

<E602-XXYY>

- XX= '00'

T-16-3

XX	YY	Description	Remedy
00	01	The HDD is not recognized. At start-up, the start-up partition (BOOTDEV) is not found.	1. Turn off the power, and check the HDD cable for disconnection; then, turn the power back on. 2. Turn on the power, and put your ear or finger against the HDD to see if the disk inside it is rotating. 3. Replace the HDD. 4. Replace the main controller PCB.
	02	The system software for the main CPU is absent.	1. Start up in safe mode, and execute full formatting using the SST; then, re-install the system software, and turn off and then on the power. 2. Replace the HDD.
	03	An interrupt has been detected during writing to BootDevice.	1. Turn off the power, and turn it back on while holding down the 1 and 9 keys. See that the auto write interrupt sector repair routine starts and the control panel goes black. 2. See the progress of operation on the display (at the start, the upper left cursor will flash). When the display goes white, turn off and then back on the power. 3. Start in safe mode, and execute full formatting using the SST. Then, re-install the system software, and turn off and then back on the power.
	04	No incidence.	
	05	No incidence.	
	06	Error in sub CPU system undetected.	1. Start up in safe mode, and execute full formatting using the SST; then, re-install the system software, and turn off and then on the power. 2. Replace the HDD.
	07	Error in ICC Profile undetected.	1. Start up in safe mode, and execute full formatting using the SST; then, re-install the system software, and turn off and then on the power. 2. Replace the HDD.

- XX= '01 to FF'

T-16-4

XX				YY							
XX	CHK-TYPE	Partition	Description	At start-up			During operation				
				03	05	00,01,02,04	11,21	13,25	10,12,14,22,23,24		
				Remedy			Remedy				
01	1	FSTDEV	compressed image data (e.g., Box)	*1	*5	*9	*10	*11	*12		
02		IMG_MNG	file management table, profile								
03		FSTCDEV	job archiving (chasing)								
04	2	APL_GEN	general data								
05		TMP_GEN	general data (temporary file)								
06		TMP_FAX	for fax (temporary file)								
07		TMP_PSS	for PDL spool (temporary file)								
08	3	PDLDEV	for PDL spool (e.g., font)								
09	4	BOOTDEV	firmware (system, MEAP, key, certificate, PDF dictionary, RUI content, audio dictionary)							*3	*8
10	5	APL_MEAP	MEAP application							*1	*5
11	6	APL_SEND	address book, filter							*2	*5
12	7	APL_KEEP	MEAP save data							*3	*8
13	8	APL_LOG	System log saving capacity							*1	*5
FF	0	Not identified	full check on HDD for faulty sector and recovery	*4	*7						

T-16-5

	YY	Description	Remedy
*1	03	An ongoing write operation is interrupted (at start-up).	1. Set '0' to CHK-TYPE, and execute HD-CHECK; then, turn off and then back on the power. 2. Type in CHK-TYPE that corresponds to the partition in question, and execute HD-CLEAR; then, turn off and then back on the power.
*2			1. Ask the user to download the address book data using a remote UI. 2. Set '0' to CHK-TYPE, and execute HD-CHECK; thereafter, turn off and then on the power. 3. Start download mode, and execute full formatting using the SST; thereafter, turn off and then back on the power.
*3			The recovery operation for the boot partition necessarily requires the use of the SST in safe mode. 1. Set '0' for CHK-TYPE, and execute HD-CHECK; thereafter, turn off and then back on the power. 2. Start download mode, and execute full formatting and re-install the system software; thereafter, turn off and then back on the power.
*4			1. Set '0' to CHK-TYPE, and execute HD-CHECK; then, turn off and then back on the power. 2. Execute HD-CLEAR by setting '1', '2', '3', and '5' to CHK-type; then, turn off and then back on the power.
*5	05	A file system error has occurred.	1. Type in CHK-TYPE corresponding to the partition in question, and execute HD-CLEAR; then, turn off and then back on the power. 2. Replace the HDD, and re-install the system software.
*6			The machine does not permit execution of HD-CLEAR in service mode (to prevent loss of partition information such as address book and filter data). 1. Ask the user to download the address book data using a remote UI. 2. Start download mode from service mode; then, execute full formatting using the SST, and re-install the system software. Thereafter, turn off and then back on the power.
*7			1. Execute HD-CLEAR by setting "1", "2", "3", and "5" to CHK-TYPE; then, turn off and then back on the power. 2. Replace the HDD, and re-install the system software.
*8			Recovery operation for the Boot partition necessarily requires the use of the SST in safe mode. 1. Start in safe mode, and execute full formatting in the SST, and re-install the system software. Thereafter, turn off and then on the power. 2. Replace the HDD, and re-install the system software.
*9	00 01 02 04	There is poor contact for the HDD, or there is a system error.	1. Check the cables and power cord for disconnection. 2. Start up in safe mode; then, execute full formatting using the SST, and re-install the system software. Thereafter, turn off and then back on the power. 3. Replace the HDD, and re-install the system software.
*10	11 21	There is poor connection of the HDD.	1. Check the cable and the power connectors for disconnection. 2. Replace the HDD, and re-install the system software.
*11	13 25	A write operation has been suspended.	File data as of Box on the HDD may be damaged. 1. Set '0' for CHK-TYPE, and execute HD-CHECK; then, turn off and then back on the power. 2. Set '1' for CHK-TYPE, and execute HD-CLEAR. (In the case of APL_SEND or BOOTDEV, reformat using the SST and re-install the system software.) 3. Replace the HDD, and re-install the system software.

	YY	Description	Remedy
*12	10 12 14 22 23 24	There is a system error or a packet data error.	1. Start up in safe mode; then, execute full formatting using the SST, and re-install the system software. Thereafter, turn off and then back on the power. 2. Replace the HDD, and re-install the system software.

## 16.3 Error Code (SEND)

### 16.3.1 Results of Self-Diagnosis

iR5065 / iR 5055 / iR5075 / iR5075N / iR5065N / iR5055N

T-16-6

Cause	Remedy
<b>There is a shortage of TCP/IP resources. Try again later.</b>	
While continuous transmission is under way or has ended in FTP or Windows (SMB), a shortage of TCP/IP resources has occurred, not permitting reference.	Wait a while; then, try again.
<b>Set the IP address.</b>	
The IP address of the machine has yet to be set.	In user mode, set the IP address; thereafter, turn off and then on the machine.
<b>The server does not respond. Check the settings.</b>	
The settings of the selected server are not correct, or the server has not been turned on. Or, there may be a shortage of resources.	Wait a while; then, try again. If browsing is still not permitted, select a different server.
<b>NetWare is in use. Try again later.</b>	
NetWare is printing using PSeve or NDSPServer, not permitting browsing.	Wait until NetWare finishes printing; then, try again.
<b>The layer in question at the target is too deep to browse.</b>	
The number of characters is in excess of the number allowed.	The layer in question cannot be specified. Specify a different address.
<b>There is no response.</b>	
The server is not ready for file transmission.	Check the target.
The network is cut for file transmission. (An attempt to connect to the target of transmission may have failed, or there is an open circuit in the middle.)	Check the network.
The tree name is not specified for NetWare transmission.	Type in the tree name.
An error has occurred for TCP/IP in the course of e-mail or i-fax transmission.	Check the condition of the network cable and the connector.
<b>Check TCP/IP.</b>	
The machine's TCP/IP is not in operation.	In user mode, check the TCP/IP settings (IP address, DHCP, RARP, BOOTP).
<b>The selected server cannot be found. Check the settings.</b>	
The IP address in question cannot be identified.	1. In user mode, check the DNS settings. 2. On the DNS side, check the DNS data settings.
If the login information for the LDAP server is set to 'use (security authentication)', the host name in question cannot be identified.	In user mode, check the TCP/IP settings (DNS settings).
<b>The selected server cannot be connected. Check the settings.</b>	

Cause	Remedy
An attempt to connect to the IP address/port in question fails.	<ol style="list-style-type: none"> <li>1. In user mode, check the TCP/IP settings (gateway address of the IP address settings).</li> <li>2. In user mode, check the LDAP server settings.</li> <li>3. Check to see that the LDAP server is operating normally.</li> <li>4. If the login information of the LDAP server is set to 'use (security authentication)', check to see if the UDP packet is blocked by a filter.</li> </ol>
<b>Check the user name, password, or the settings.</b>	
If the login information of the LDAP server is set to 'use' or 'use (security authentication)', the user name or the password is wrong.	In user mode, check the LDAP server settings (user name, password).
If the login information of the LDAP server is set to 'use (security authentication)', the domain name is wrong.	In user mode, check the LDAP server settings (domain name).
<b>A timeout condition has occurred, and a search cannot be completed. Check the settings.</b>	
The search cannot be completed within the specified period of time.	In user mode, increase the length of time before a timeout condition occurs (part of LDAP server settings).
<b>An upper limit for search results has been exceeded. If the desired address is not indicated in the results, change the search conditions.</b>	
The number of matches has exceeded the number of results brought up in response to the search.	<ol style="list-style-type: none"> <li>1. Narrow down the search conditions, and try again.</li> <li>2. Try increasing the upper limit.</li> </ol>
<b>The search conditions include a character that cannot be used for the selected server.</b>	
The symbol \ is used in the search condition.	Remove the symbol \ from the search condition, and try once again.
The combination of characters used in the search condition fails to make up a correct search condition. There must be as many "s as there are "s The symbol * is not included within parentheses.	Check to be sure that the combination of characters is in keeping with the rule; then, try once again.
If LDAP of the server and the character code is version 2 (JIS), there is a character that is not part of the ASCII code (0x20-0x7E).	Remove any character that cannot be used; then, try once gain.
<b>The version setting of the server is wrong, and the search cannot be initiated. Check the settings.</b>	
In user mode, the LDAP server settings (server LDAP version and character code) is set for version 3; however, the LDAP server is operating for version 2.	In user mode, set the LDAP server settings so that the LDAP server version and the character code are both version 2.

### 16.3.2 Error Codes

iR5065 / iR 5055 / iR5075 / iR5075N / iR5065N / iR5055N

T-16-7

Cause	Remedy
<b># 001</b>	
There is a paper or original jam.	Remove the jammed paper or original.
<b># 003</b>	
A communication lasting longer than a specific period of time (64 min) will cause an error state.	<ol style="list-style-type: none"> <li>1. Decrease the resolution for transmission.</li> <li>2. In the case of reception, ask the source to decrease the resolution or divide the original.</li> </ol>
<b># 005</b>	
The target does not respond within 35 sec.	Check to be sure that the target is ready to communicate; then, try once again.
The target is a non-G3 model.	Check the target.
<b># 009</b>	
There is no paper.	Supply paper.

Cause	Remedy
The cassette is not fitted properly.	Fit the cassette correctly.
<b># 011</b>	
The original to be transmitted is not placed properly.	Start over from the beginning.
<b># 012</b>	
The target is out of recording paper, and transmission has failed.	Ask the target to supply recording paper.
<b># 018</b>	
There is no response to a redial attempt.	Check to make sure that the target is ready for communication; then, try once again.
The target is engaged for a different communication, and transmission has failed.	Check to make sure that the target is ready for communication; then, try once again.
The settings do not match the settings of the target, and the transmission has failed.	Check to make sure that the target is ready for communication; then, try once again.
<b># 022</b>	
The particulars of the group address selected as the forwarding target may have been deleted, or there is no more than a user box, thus causing the transmission to fail.	Try transmitting once again.
The attempt to transmit to an address registered in the address book has failed because the address has been removed from the address table while in wait for transmission.	Try once again.
<b># 037</b>	
There is a shortage of memory, not permitting reception.	Remove error files and unnecessary files to increase available memory.
<b># 080</b>	
F code is not set on the target.	Check the F code of the target, and start over.
<b># 081</b>	
The appropriate password is not set on the target.	Check the password of the target, and start over.
<b># 099</b>	
The transmission has been suspended in the middle.	Start over.
<b># 102</b>	
There is a mismatch of F code or password.	Check the F code and the password of the target, and start over.
<b># 107</b>	
There is a shortage of memory, not permitting transmission.	1. Decrease the resolution, and try once again. 2. Remove unnecessary files to increase available space.
<b># 701</b>	
The group ID set when the job was introduced no longer exists. Or, the password has been changed.	Type in the correct group ID or the ID No. (using the keypad); then, start over.
<b># 702</b>	
The memory is full, not permitting transmission.	1. Wait a while. Try again until the ongoing transmission of a job ends. 2. Try not to transmit to too many addresses at once; rather, try dividing the address into smaller groups.
<b># 703</b>	
The memory image area is full, not permitting further writing.	1. Wait a while. Try transmitting after the ongoing transmission of a job ends. 2. Remove files from the Box; if the operation still fails to return to normal, turn off and then back on the main power.
<b># 704</b>	
An error has occurred while an attempt is made to obtain address information from the address book.	Check the settings of the address, and try once again; if the operation is still not normal, try turning off and then back on the main power.
<b># 705</b>	



Cause	Remedy
The image data size is in excess of the upper limit imposed on transmission data size set in user mode, thus causing suspension of transmission.	Try changing the upper limit imposed on transmission data size as part of the communication control settings of system control settings (user mode). When selecting low resolution mode or using i-fax, try decreasing the number of images to send at one time so that the transmission will not be in excess of the upper limit imposed on transfer data size.
<b># 706</b>	
An address table is being imported from or to the remote UI; or, a different transmission component is being used.	Start over once again.
<b># 711</b>	
All memory of the Box is used.	Delete files from the Box.
<b># 712</b>	
The Box is full of files.	Remove file from the Box.
<b># 713</b>	
The file has been removed from the Box before transmitting the URL.	Put the file in question back into the Box, and start over.
<b># 751</b>	
The server is yet to start up. The network is disconnected. (The connection to the target may have failed, or the connection may have been cut in the middle.)	Check the target. Check the network.
<b># 752</b>	
The SMTP server name of the e-main/i-fax in question may be wrong, or the server in question is yet to start up. Or, the appropriate domain name or e-mail address has not been set. Or, the network has been disconnected.	Using the network settings of the system control setup (user mode), check the SMTP server name, domain name, and e-mail address. Check to see that the SMTP server is operating normally. Check the connection of the network.
<b># 753</b>	
A TCP/IP error has occurred in the course of e-mail transmission. (e.g., socket, select error)	Check the condition of the network cable and the connector. If the operation does not return to normal, try turning off and then back on the main power of the machine.
<b># 754</b>	
The server has not been started up for transmission, or the network is disconnected. Or, the target settings are wrong.	Check the server and the network. Check the settings of the target.
<b># 755</b>	
The TCP/IP settings are not operating normally, thus not permitting transmission.	In user mode, check the TCP/IP settings.
The appropriate IP address has not been set up.	In user mode, check the TCP/IP settings.
When the machine is started up, its IP address is not assigned by means of DHCP, RARP, or BOOTP.	In user mode, check the TCP/IP settings.
<b># 756</b>	
In system control setup (user mode), 'use NetWare' is set to 'off' in NetWare settings.	In network settings of system control setup (user mode), set 'use NetWare' to 'on'.
<b># 801</b>	
While e-mail is being transmitted or i-fax is transmitted/received, the communication with the SMTP server encountered a timeout error because of a factor associated with the main server.	<ol style="list-style-type: none"> <li>1. Check to see that SMTP is operating normally.</li> <li>2. Check the condition of the network.</li> </ol>
While an SMTP connection is being used, the SMTP server has returned an error. The address setting is not correct. When data is transmitted to the file server, an error has occurred owing to a factor associated with the server.	<ol style="list-style-type: none"> <li>1. Check to see if SMTP is operating normally.</li> <li>2. Check the condition of the network.</li> <li>3. Check the address setting.</li> <li>4. Check the condition of the file server and the setting.</li> </ol>

Cause	Remedy
An attempt has been made to transmit data to an address not authorized for a write operation.	Check the address setting.
In the course of transmitting data (file server), it was found that there is a file having the same name, and an overwrite operation to the file is prohibited.	Change the setting of the file server so that overwriting may be permitted.
In relation to transmission (file server), the folder name or the password that has been specified is wrong.	Check the address setting.
<b># 802</b>	
In the system control setup (user mode), the settings of the SMTP server for e-mail/i-fax are wrong. The setting of the DNS server is wrong. The attempt to connect to the DNS server has failed.	In the network settings under system control settings (user mode), check the SMTP server name and the DNS server name. Check to see if the DNS server is operating normally.
<b># 803</b>	
Before all pages have been transmitted, the target has cut off the network.	Try once again.
<b># 804</b>	
When an attempt is made to transmit to the file server, it has been found that no match exists in the specified directory.	Check the address.
You are not authorized for access to the folder.	Set the server so that you will be authorized to access the folder.
<b># 806</b>	
When an attempt to transmit to the file server is made, it has been found that the specified user name or password is wrong.	Change the user name or the password of the address.
The address specified for e-mail/i-fax transmission is wrong.	Check the address of the e-mail/i-fax in question.
<b># 810</b>	
When an attempt is made to receive i-fax, a POP server connection error has occurred.	1. In user mode, check the POP server name setting. 2. Check the operation of the POP server. 3. Check the condition of the network.
While a connection is made to the POP server, an error has been returned by the POP server.	1. In user mode, check the POP server name setting. 2. Check the operation of the POP server. 3. Check the condition of the network.
While a connection is made to the POP server, a timeout error has occurred owing to a factor associated with the server.	1. In user mode, check the POP server name setting. 2. Check the operation of the POP server. 3. Check the condition of the network.
<b># 815</b>	
If a file that has been transmitted to the file server is being printed, you will not be able to log in to the server in question.	Wait a while, and then try once again. Or, change the NetWare server settings of the target, or stop PServer.
<b># 818</b>	
The data that has been received is in a format that does not permit printing.	Ask the source to change the file format and transmit it once again.
<b># 819</b>	
The data that has been received is of a type that cannot be handled (i.e., its MIME information is illegal).	Ask the target to check the settings and transmit it once again.
<b># 820</b>	
The data that has been received is of a type that cannot be handled (i.e., BASE64 or Unicode is illegal).	Ask the source to check the settings and transmit it once again.

Cause	Remedy
<b># 821</b>	
The data that has been received is of a type that cannot be handled (i.e., TIFF interpretation error has occurred).	Ask the target to check the settings and transmit once again.
<b># 822</b>	
The data that has been received is of a type that cannot be handled (i.e., the image cannot be decoded).	Ask the source to check the settings and transmit once again.
<b># 827</b>	
The data that has been received is of a type that cannot be handled (i.e., part of its MIME information is not supported).	Ask the source to check the settings and transmit once again.
<b># 828</b>	
HTML data has been received.	Ask the source to use a format other than HTML.
<b># 829</b>	
The data that is being received consists of 100 pages or more.	The machine is designed so that it removes data for the 100th and subsequent pages and prints or saves in memory up to the 999th page. Ask the source to transmit the remaining pages one again.
<b># 830</b>	
A DSN error notice has been received because of the following: the i-fax address or the target settings are wrong, or the data of the file that has been transmitted is greater than the size permitted by the mail server.	<ol style="list-style-type: none"> <li>1. Check the i-fax address and the target settings.</li> <li>2. In user mode, decrease the upper limit imposed on the size of transmission data so that it is lower than the size permitted by the mail server.</li> <li>3. Check the condition of the mail server, DNS server, and network.</li> </ol>
<b># 831</b>	
An attempt to receive i-fax in SMTP has failed because of the reception/printing range settings made as part of the IP address range setting in user mode.	Change the reception/printing range settings made as part of the IP address range setting in user mode.
<b># 832</b>	
In user mode, the e-mail setting or the network setting is yet to be made, causing a mail server fault and, thus, preventing reception of MDN (transmission confirmation) mail.	<ol style="list-style-type: none"> <li>1. In user mode, check the DNS setting, e-mail/i-fax setting, and IP address made as part of the network settings.</li> <li>2. Check the condition of the mail server and the DNS server.</li> </ol>
<b># 833</b>	
The network settings have not been made in user mode or there is a mail-server related fault, thus preventing the transmission of the mail (MDN; transmission acknowledgement).	<ol style="list-style-type: none"> <li>1. In user mode, check the DNS setting, e-mail/i-fax setting, and IP address made as part of the network settings.</li> <li>2. Check the condition of the mail server and the DNS server.</li> </ol>
<b># 834</b>	
The i-fax address or the condition settings of the target may be wrong, there may be a fault in the network or the mail server, or the target may have encountered a memory full condition, thus causing an MDS error notice.	Check the specified i-fax address and the target conditions.
<b># 835</b>	
The number of text lines is more than the maximum number of lines permitted for i-fax.	Ask the target to decrease the number of text lines and try once again.
<b># 837</b>	
A request has been made by a host that comes under the restrictions imposed by 'IP address range setting' in user mode.	Check the setting of the IP address range in user mode. The attempt to access in question may be illegal.
<b># 839</b>	
The SMTP authentication (SMTPAUTH) user name or password for e-mail/i-fax (network settings) may be wrong.	Check the user name and password used for SMTP authentication (SMTPAUTH) as part of the network settings under system control settings (user mode).

Cause	Remedy
<b># 841</b>	
In relation to an attempt for transmission for e-mail/i-fax, there is no coding algorithm that may be used in common with the mail server.	1. Set 'SSL' to 'OFF' as part of the network settings under system control settings (user mode). 2. Add a coding algorithm that may be used in common (mail server settings).
<b># 842</b>	
In relation to an attempt for transmission of e-mail/i-fax, a request has been made for the use of a client certificate by the mail server.	1. Set 'SSL' to 'OFF' as part of the network settings under the system control settings (user mode). 2. Change the mail server settings so that it will not request a client certificate.
<b># 843</b>	
The time used by the KDC (key distribution center) server and the time used by the machine are different significantly.	1. Correct the time as part of the date/time settings under the system control settings (user mode). 2. Correct the time used by the KDC (key distribution center) server.
<b># 847</b>	
The memory of the Box has been used up, not permitting the storage of the received file in the fax box.	Remove unnecessary files from the fax box or the system box.
<b># 851</b>	
The remaining memory of the machine is running short.	Check the remaining memory of the machine; then, remove unnecessary files for the Box.
There are more than 100 files in the specified box, not permitting additional storage.	Remove unnecessary files from the specified box.
<b># 852</b>	
The main power switch has been turned off while a job is being executed, causing an error.	Check to see that the main power switch is on; as necessary, try once again.
<b># 899</b>	
The transmission of e-mail or i-fax has ended. However, the transmission has gone through multiple servers, and there is no way of finding out whether the transmission has reached the target.	1. Check with the target to see if the transmission has arrived. 2. Check to see if an error notice has arrived.
<b># 995</b>	
The reservation for the transmission has been cancelled.	As necessary, start over.

## 16.4 Jam Code

### 16.4.1 Jam Code (machine proper)

iR5065 / iR 5055 / iR5075 / iR5075N / iR5065N / iR5055N

T-16-8

Code	Jam
01xx	delay jam
02xx	stationary jam
0Axx	residual jam
0Bxx	cover open jam

T-16-9

Code	Sensor	Notation
xx01	registration paper sensor	PS29
xx02	write check sensor	PS28
xx03	vertical path 1 paper sensor	PS24
xx04	vertical path 2 paper sensor	PS25
xx05	vertical path 3 paper sensor	PS26
xx06	vertical path 4 paper sensor	PS27
xx07	right deck pull-off sensor	PS32
xx08	left deck pull-off sensor	PS33
xx0B	right deck retry sensor	PS19

Code	Sensor	Notation
xx0C	left deck retry sensor	PS20
xx0D	cassette 3 retry sensor	PS21
xx0E	cassette 4 delivery sensor	PS22
xx0F	fixing claw jam sensor	PS4
xx10	inside delivery sensor	PS35
xx11	outside delivery sensor	PS36
xx12	delivery jam sensor	PS46
xx13	reversal sensor 2	PS38
xx14	delivery sensor 1	PS37
xx15	duplexing paper sensor	PS34
xx16	duplexing pre-registration sensor	PS30
xx17	fixing outlet sensor	PS52
xx18	fixing inlet sensor	PS51

#### 16.4.2 Jam Code (finisher-related)

iR5065 / iR 5055 / iR5075 / iR5075N / iR5065N / iR5055N

T-16-10

Code	jam
1001	inlet path sensor delay jam
1002	punch path sensor feed delay jam
1003	escape path sensor feed delay jam
1004	delivery path sensor delay jam
1101	inlet path sensor stationary jam
1102	punch path sensor feed stationary jam
1103	escape path sensor feed stationary jam
1104	delivery path sensor stationary jam
1200	finisher timing jam
1300	power-on jam
1400	door open jam
1500	stapler staple jam
1644	punch jam
1645	punch residual jam
1791	saddle feed path sensor feed delay jam
1792	saddle delivery sensor feed delay jam
1793	saddle inlet sensor feed delay jam
17A1	saddle feed path sensor feed stationary jam
17A2	saddle delivery sensor feed stationary jam
17A3	saddle inlet sensor feed stationary jam
1786	saddle stapler staple jam
1787	saddle power-on jam
1788	saddle door open jam
17B1	document registration sensor delay jam
17B2	reversing inlet sensor delay jam
17B3	reversing sensor delay jam
17B4	reversing timing sensor delay jam
17B5	deacceleration timing sensor delay jam
17B6	separation timing sensor delay jam
17B7	folding position accuracy sensor delay jam
17B8	upper stopper assembly path sensor delay jam
17B9	delivery 1 sensor delay jam
17BA	delivery 2 sensor delay jam
17BB	3-fold tray empty sensor delay jam
17C1	document registration sensor stationary jam
17C2	reversing inlet sensor stationary jam
17C3	reversing sensor stationary jam
17C4	reversing timing sensor stationary jam
17C5	deacceleration timing sensor delay jam
17C6	separation timing sensor stationary jam
17C7	folding position accuracy sensor stationary jam
17C8	upper stopper assembly path sensor stationary jam
17C9	delivery 1 sensor stationary jam
17CA	delivery 2 sensor stationary jam

Code	jam
17CB	3-fold tray empty sensor stationary jam
17D1	inserter paper absent jam
17D7	inserter power on jam
17D8	inserter door open jam

### 16.4.3 Jam Code (ADF-related)

iR5065 / iR 5055 / iR5075 / iR5075N / iR5065N / iR5055N

T-16-11

Code	Sensor	Notation	Description
0001	post-separation sensor PCB	PCB2	The post-separation sensor does not detect paper when paper has been moved 452 mm after the start of separation.
0002	post-separation sensor PCB	PCB2	- The separation sensor detects paper when paper has been moved 500 mm (if extra-length, +200 mm) -45.5 mm after registration pickup. - the sensor goes on (paper with hole) before paper has been fed 12 mm after the detection of the trailing edge; the separation sensor detects paper after paper has been fed 50 mm from when the separation sensor has gone on.
0003	registration sensor	PI1	The registration sensor does not detect paper a feed length of 134.8 mm after the post-separation sensor has gone on.
0004	registration sensor	PI1	The read sensor goes off before the registration sensor goes off.
0005	read sensor PCB	PCB3	- The read sensor does not detect paper a feed length of 364.2 mm (182.1 x 2) from the point of registration. - The read sensor does not detect paper a feed length of 157.4 mm (78.7 x 2) from the point of No. 2 registration.
0006	read sensor PCB	PCB3	- The read sensor detects paper a feed length of 500 mm (if extra-length, +200 mm) after the start of feed, resumed after a temporary stop for reading. - At time of LTRR/LGL identification in mix mode, the read sensor detects paper a feed length of 514 mm after the start of feed from the edging wait point.
0007	delivery reversal sensor PCB	PCB4	If not in high-speed duplexing mode, the delivery sensor does not detect paper when paper is moved 132.1 mm after it has reached the leading edge lower stream roller with reference to the activation of the read sensor.
0008	delivery reversal sensor PCB	PCB4	The delivery sensor detects paper a feed length of 161.9 mm after the trailing edge read end point.
0009	No.2 registration sensor	PI12	-When feeding 4 times the distance between the No.1 registration roller and the No.2 registration sensor after re-pickup from the No.1 registration roller in the simplex pickup from the tray, the No.2 registration sensor does not turn on. (82.2 X 4)mm -When feeding 4 times the distance between the reversal roller + 20 mm and the No.2 registration sensor in the reversal duplexing pickup from the reversal duplexing path, the No.2 registration sensor does not turn on. (22.6 X 4)mm
0010	No.2 registration sensor	PI12	The No.2 registration sensor detects papers when feeding the length of 500 X 2 mm after the No.2 registration sensor turned on.
0011	No.2 read sensor	PI11	The No.2 read sensor does not turn on when feeding twice the distance between the read position and the No.2 read sensor after the start of reading a document. (47.4 X 2)mm
0012	No.2 read sensor	PI11	The read sensor detects papers after feeding the length of 500 mm (+200 mm for the long one) in the detection of the No.2 read sensor
0042	post-separation sensor PCB	PCB2	1st sheet, post-separation sensor, stationary
0043	registration sensor	PI1, PI12	1st sheet, registration sensor, non arrival
0044	registration sensor	PI1, PI12	1st sheet, registration sensor, stationary
0045	read sensor	PCB3, PI11	1st sheet, read sensor, non arrival
0046	read sensor	PCB3, PI11	1st sheet, read sensor, stationary
0047	delivery reversal sensor PCB	PCB4	1st sheet, delivery sensor, non arrival
0048	delivery reversal sensor PCB	PCB4	1st sheet, delivery sensor, stationary
0049	No.2 registration sensor	PI12	1st sheet, No.2 registration sensor, non arrival
0050	No.2 registration sensor	PI12	1st sheet, No.2 registration sensor, stationary
0051	No.2 read sensor	PI11	1st sheet, No.2 read sensor, non arrival
0052	No.2 read sensor	PI11	1st sheet, No.2 read sensor, stationary
0071	TIMING NG	-	fault in software timing
0073	TIMING NG	-	fault in shift motor
0090	ADF open/closed sensor 1	PS502	The ADF has been opened while in operation.
0091	ADF open/closed sensor 1	PS502	The ADF has been opened while in operating (paper wait).
0092	DF cover open/closed sensor	PI6	The cover has been opened while in operation (drive system in operation).

Code	Sensor	Notation	Description
0093	DF cover open/closed sensor	PI6	The cover has been opened while in operation (paper wait).

## 16.5 Alarm Code

### 16.5.1 Alarm Code

iR5065 / iR 5055 / iR5075 / iR5075N / iR5065N / iR5055N

T-16-12

Location		Description	
04	pickup/feed system	0001	right deck lifter error
		0002	left deck lifter error
		0003	3rd cassette lifter error
		0004	4th cassette lifter error
		0008	optional deck lifter error
06	fixing system	0003	fixing web absent
11	drum cleaner system, collecting toner collection system	0001	collecting toner case full
30	high-voltage system	0001	primary charging assembly leakage
		0002	transfer charging assembly leakage
		0003	separation charging assembly leakage
32	potential control system	0001	potential control VD alarm
		0002	potential control VL alarm
33	fan system	0001	delivery assembly curl-removing fan alarm
		0009	duplexing feed fan alarm
		0016	exhaust fan 1 alarm
60	sorter, finisher, shift tray as a whole	0001	shift tray alarm
61	sorter/finisher stapling system	0001	staple absent
62	saddle stitching system	0001	stitch absent
65	sorter/finisher puncher system	0001	punch case full





---

## Chapter 17 Service Mode

---



---

# Contents

17.1 Outline.....	17-1
17.1.1 Service mode screen configuration.....	17-1
17.1.2 Entering or selecting service modes.....	17-1
17.1.3 Exiting service modes.....	17-2
17.1.4 Backing Up Service Mode.....	17-2
17.1.5 Initial screen.....	17-2
17.1.6 Main/intermediate item screen.....	17-3
17.1.7 Sub-item screen.....	17-3
17.2 DISPLAY (Status Display Mode).....	17-4
17.2.1 COPIER.....	17-4
17.2.1.1 COPIER List.....	17-4
17.2.2 FEEDER.....	17-11
17.2.2.1 FEEDER List.....	17-11
17.3 I/O (I/O Display Mode).....	17-12
17.3.1 Outline.....	17-12
17.3.2 R-CON.....	17-12
17.3.3 FEEDER.....	17-13
17.3.4 SORTER.....	17-14
17.3.5 MN-CON.....	17-19
17.3.6 P-CON.....	17-19
17.4 ADJUST (Adjustment Mode).....	17-23
17.4.1 COPIER.....	17-23
17.4.1.1 COPIER List.....	17-23
17.4.2 FEEDER.....	17-27
17.4.2.1 FEEDER List.....	17-27
17.4.3 SORTER.....	17-27
17.4.3.1 SORTER List.....	17-27
17.5 FUNCTION (Operation/Inspection Mode).....	17-27
17.5.1 COPIER.....	17-27
17.5.1.1 COPIER List.....	17-27
17.5.2 FEEDER.....	17-36
17.5.2.1 FEEDER List.....	17-36
17.6 OPTION (Machine Settings Mode).....	17-37
17.6.1 COPIER.....	17-37
17.6.1.1 COPIER List.....	17-37
17.6.2 FEEDER.....	17-62
17.6.2.1 FEEDER List.....	17-62
17.6.3 SORTER.....	17-62
17.6.3.1 SORTER List.....	17-62
17.6.4 BOARD.....	17-62
17.6.4.1 BOARD List.....	17-62
17.7 TEST (Test Print Mode).....	17-63
17.7.1 COPIER.....	17-63
17.7.1.1 COPIER List.....	17-63
17.8 COUNTER (Counter Mode).....	17-64
17.8.1 COPIER.....	17-64
17.8.1.1 COPIER List.....	17-64



## 17.1 Outline

### 17.1.1 Service mode screen configuration

iR5065 / iR 5055 / iR5075 / iR5075N / iR5065N / iR5055N

As shown below, the service modes use three screen levels: initial screen -> main/intermediate item screen -> sub-item screen. One set of modes are used for normal maintenance (Level 1 modes), and another set are used for troubleshooting (Level 2 modes).

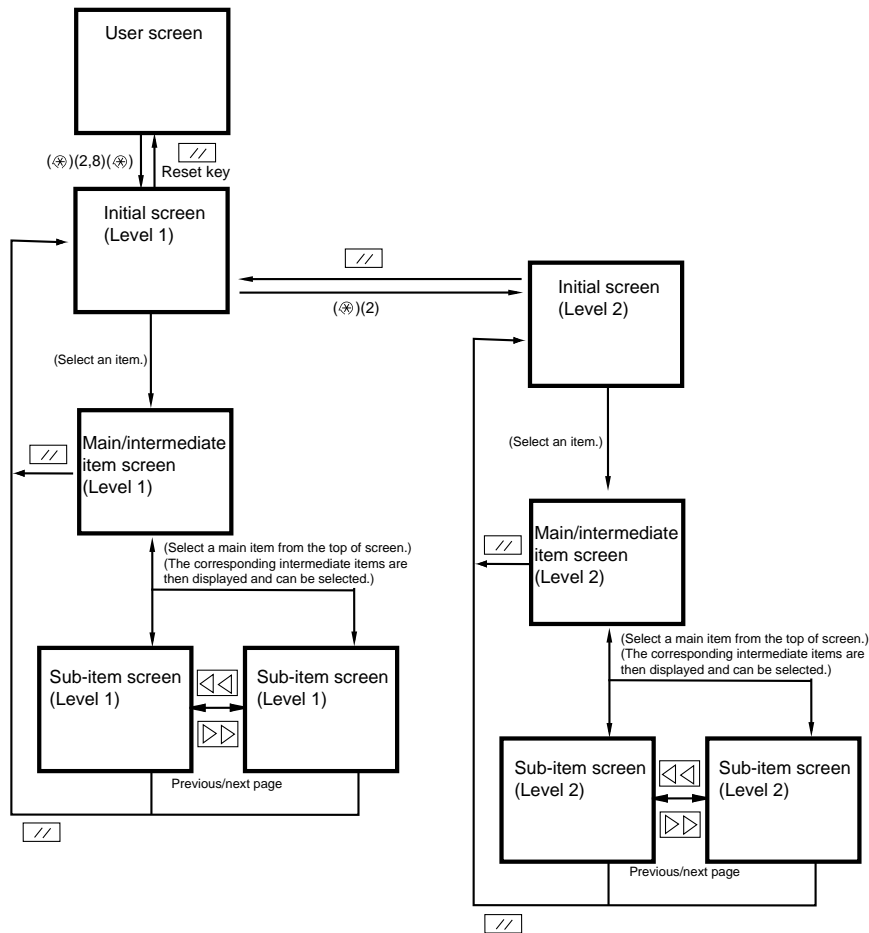

F-17-1

The copier has the 7 service modes listed below.

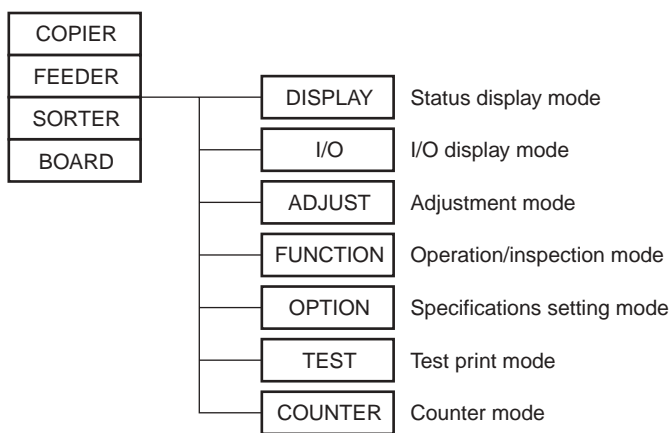



F-17-2

### 17.1.2 Entering or selecting service modes

iR5065 / iR 5055 / iR5075 / iR5075N / iR5065N / iR5055N



To execute a copier operation using a service mode, remove the cable from the external controller or the cable from the network before entering the desired mode. Take care when using the FUNCTION (operation/inspection mode) mode, as the copier may malfunction and be damaged if a print job is received from outside while an operation is executing with this mode in effect.

- 1) Press the asterisk key () on the operation panel.
- 2) Press 2 and 8 simultaneously on the numeric keypad.
- 3) Press the asterisk key () on the operation panel.  
The initial screen (see below) now appears.

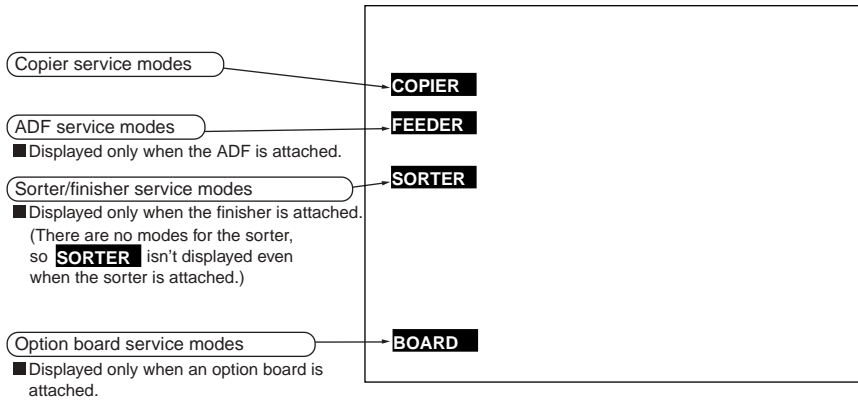

F-17-3

### 17.1.3 Exiting service modes

iR5065 / iR 5055 / iR5075 / iR5075N / iR5065N / iR5055N

When the reset key is pressed once, the display returns to the service mode initial screen.  
When the reset key is pressed twice, the service modes are exited, and the display returns to the user screen (standard screen).



When using the ADJUST, FUNCTION or OPTION service mode, be sure to turn the main power switch ON/OFF after exiting the mode.

### 17.1.4 Backing Up Service Mode

iR5065 / iR 5055 / iR5075 / iR5075N / iR5065N / iR5055N

All machines are inspected at time of shipment, and adjustment values are recorded on their service labels. If you have replaced the reader controller PCB or the DC controller PCB, or if you have initialized the RAM, ADJUST and OPTION will be reset to their default settings. If you have made adjustments and changed any of the settings, be sure to update the settings recorded on the service label. If specific items are missing on the label, use its blank space.

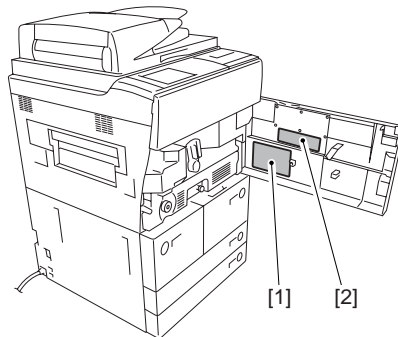

F-17-4

- [1] Service label (for main controller PCB/DC controller PCB)
- [2] Service label (for reader controller PCB)

### 17.1.5 Initial screen

iR5065 / iR 5055 / iR5075 / iR5075N / iR5065N / iR5055N

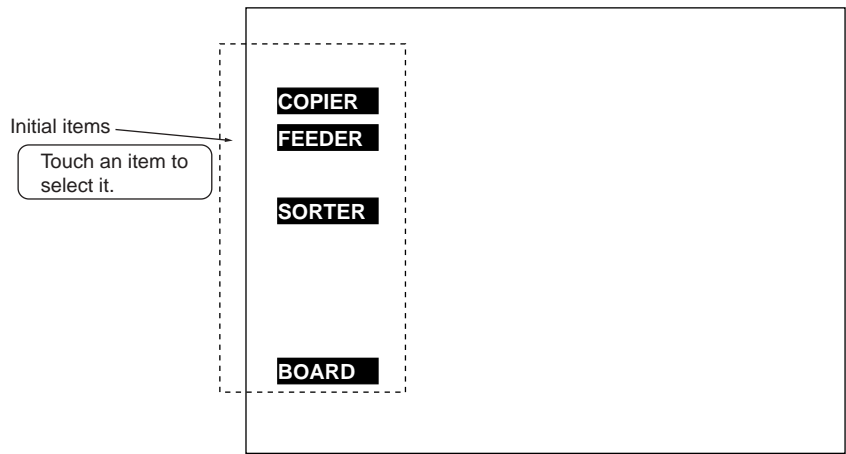

F-17-5

**17.1.6 Main/intermediate item screen**

iR5065 / iR 5055 / iR5075 / iR5075N / iR5065N / iR5055N

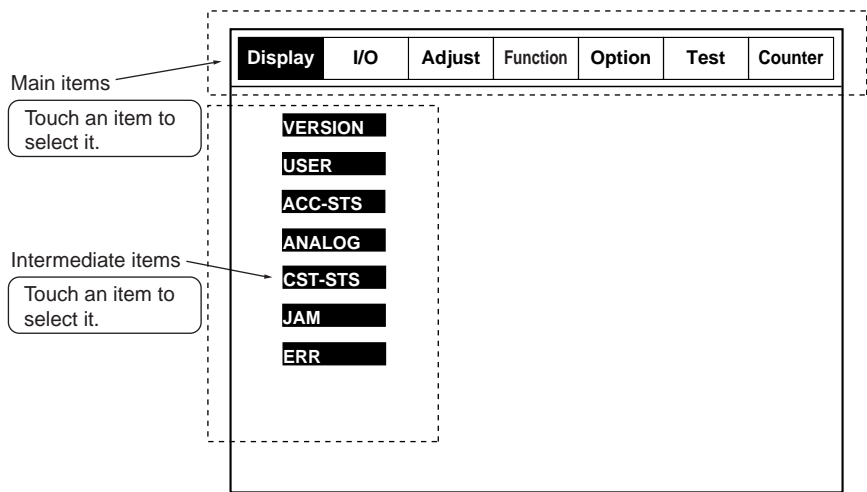

F-17-6

**17.1.7 Sub-item screen**

iR5065 / iR 5055 / iR5075 / iR5075N / iR5065N / iR5055N

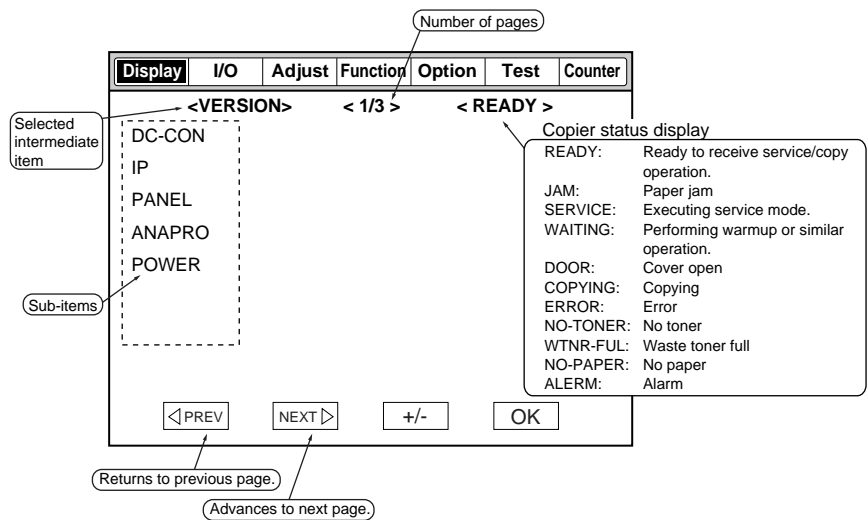

F-17-7

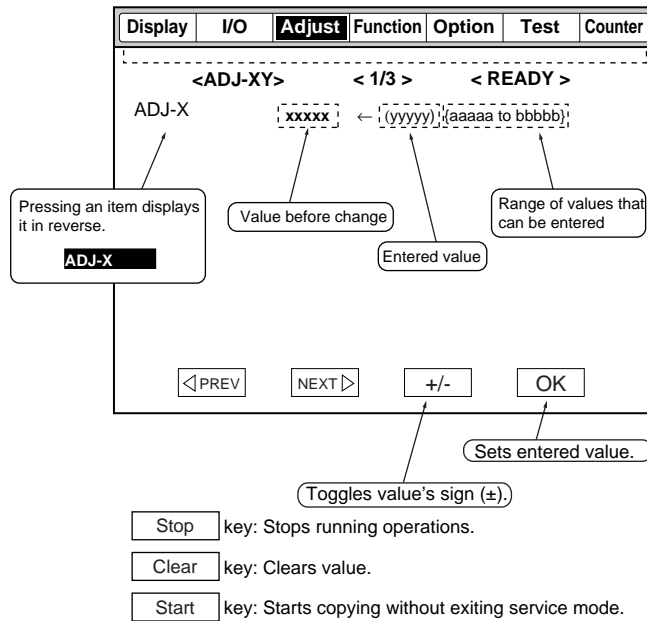

F-17-8

## 17.2 DISPLAY (Status Display Mode)

### 17.2.1 COPIER

#### 17.2.1.1 COPIER List

iR5065 / iR 5055 / iR5075 / iR5075N / iR5065N / iR5055N

<VERSION>

T-17-1

COPIER > DISPLAY > VERSION		
Sub-item	Description	Level
Use it to indicate the ROM version of a particular PCB (copier and accessory). -if <R-CON XX.YY>, XX indicates the version number and the YY, R&D control number. -if no PCB is connected, the indication will be <-,->.		
DC-CON	indicates the ROM version of the DC controller PCB.	1
R-CON	indicates the ROM version of the reader controller PCB.	1
PANEL	indicates the ROM version of the control panel CPU PCB.	1
FEEDER	indicates the ROM version of the DADF controller PCB.	1
SORTER	indicates the ROM version of the finisher controller PCB.	1
FAX	indicates the ROM version of the fax control PCB (for 2-line configuration).	1
NIB	indicates the version of the network software.	1
SDL-STCH	indicates the ROM version of the saddle stitcher controller PCB.	1
MN-CONT	indicates the ROM version of the main controller PCB.	1
DIAG-DVC	indicates the ROM version of the self-diagnosis device.	1
RUI	indicates the version of the remote UI.	1
PUNCH	indicates the version of the punch unit.	1
LANG-EN	indicates the version of the English language file.	1
LANG-FR	indicates the version of the French language file.	1
LANG-DE	indicates the version of the German language file.	1
LANG-IT	indicates the version of the Italian language file.	1
LANG-JP	indicates the version of the Japanese language file.	1
JAVA-VM	indicates the version of JavaVM built into bootable.	1
MEAP	indicates the version of the MEAP content on the hard disk.	1
OCR-CN	indicates the version of OCR of the Chinese language file (simplified).	1
OCR-JP	indicates the version of OCR of the Japanese language file.	1
OCR-KR	indicates the version of OCR of the Korean language file.	1
OCR-TW	indicates the version of OCR of the Chinese language file (traditional).	1
BOOTROM	indicates the version of boot ROM of the main controller PCB. in "xx.yy_z," "z" indicate the type of boot ROM.	1
TTS-JA	indicates the version of the Japanese language audio dictionary.	1
TTS-EN	indicates the version of the English language audio dictionary.	1
WEB-BRWS	indicates the version of the web browser.	1
HELP	indicates the version of the Simple Navigation.	1
FIN-INS	indicates the version of the Folding/Inserting unit.	1



COPIER > DISPLAY > VERSION		
Sub-item	Description	Level
WEBDAV	indicates the version of the WEBDAV.	1
TIMESTMP	indicates the version of the Timestamp.	1
LANG-CS	indicates the version of the Czech language file.	2
LANG-DA	indicates the version of the Danish language file.	2
LANG-EL	indicates the version of the Greek language file.	2
LANG-ES	indicates the version of the Spanish language file.	2
LANG-ET	indicates the version of the Estonian language file.	2
LANG-FI	indicates the version of the Finish language file.	2
LANG-HU	indicates the version of the Hungarian language file.	2
LANG-KO	indicates the version for the Korean language file.	2
LANG-NL	indicates the version of the Dutch language file.	2
LANG-NO	indicates the version of the Norwegian language file.	2
LANG-PL	indicates the version of the Polish language file.	2
LANG-PT	indicates the version of the Portuguese language file.	2
LANG-RU	indicates the version of the Russian language file.	2
LANG-SL	indicates the version of the Slovenian language file.	2
LANG-SV	indicates the version of the Swedish language file.	2
LANG-TW	indicates the version of the Chinese language file (traditional).	2
LANG-ZH	indicates the version of the Chinese language file (simplified).	2
LANG-BU	indicates the version of the Bulgarian language file.	2
LANG-CR	indicates the version of the Croatian language file.	2
LANG-RM	indicates the version of the Romanian language file.	2
LANG-SK	indicates the version of the Slovakian language file.	2
LANG-TK	indicates the version of the Turkish language file.	2
LANG-CA	indicates the version of the Catalan language file.	2
MEDIA-JA	Version of the Japanese paper brand information  Only supports iR5075/5065/5055 Series V2. (BODY No. CHL XXXX, CHM XXXX, CHN XXXX, CHP XXXX, CHQ XXXX, CHU XXXX, CHV XXXX, CHW XXXX, CHZ XXXX, CJA XXXX, CJD XXXX, CJE XXXX, CJK XXXX, CJP XXXX, CJQ XXXX, CJR XXXX, CJU XXXX, CJZ XXXX, CKA XXXX, CKC XXXX, CKD XXXX, CKE XXXX)	2
MEDIA-EN	Version of the English paper brand information  Only supports iR5075/5065/5055 Series V2. (BODY No. CHL XXXX, CHM XXXX, CHN XXXX, CHP XXXX, CHQ XXXX, CHU XXXX, CHV XXXX, CHW XXXX, CHZ XXXX, CJA XXXX, CJD XXXX, CJE XXXX, CJK XXXX, CJP XXXX, CJQ XXXX, CJR XXXX, CJU XXXX, CJZ XXXX, CKA XXXX, CKC XXXX, CKD XXXX, CKE XXXX)	2
MEDIA-DE	Version of the German paper brand information  Only supports iR5075/5065/5055 Series V2. (BODY No. CHL XXXX, CHM XXXX, CHN XXXX, CHP XXXX, CHQ XXXX, CHU XXXX, CHV XXXX, CHW XXXX, CHZ XXXX, CJA XXXX, CJD XXXX, CJE XXXX, CJK XXXX, CJP XXXX, CJQ XXXX, CJR XXXX, CJU XXXX, CJZ XXXX, CKA XXXX, CKC XXXX, CKD XXXX, CKE XXXX)	2
MEDIA-IT	Version of the Italian paper brand information  Only supports iR5075/5065/5055 Series V2. (BODY No. CHL XXXX, CHM XXXX, CHN XXXX, CHP XXXX, CHQ XXXX, CHU XXXX, CHV XXXX, CHW XXXX, CHZ XXXX, CJA XXXX, CJD XXXX, CJE XXXX, CJK XXXX, CJP XXXX, CJQ XXXX, CJR XXXX, CJU XXXX, CJZ XXXX, CKA XXXX, CKC XXXX, CKD XXXX, CKE XXXX)	2
MEDIA-FR	Version of the French paper brand information  Only supports iR5075/5065/5055 Series V2. (BODY No. CHL XXXX, CHM XXXX, CHN XXXX, CHP XXXX, CHQ XXXX, CHU XXXX, CHV XXXX, CHW XXXX, CHZ XXXX, CJA XXXX, CJD XXXX, CJE XXXX, CJK XXXX, CJP XXXX, CJQ XXXX, CJR XXXX, CJU XXXX, CJZ XXXX, CKA XXXX, CKC XXXX, CKD XXXX, CKE XXXX)	2
MEDIA-ZH	Version of the simplified Chinese paper brand information  Only supports iR5075/5065/5055 Series V2. (BODY No. CHL XXXX, CHM XXXX, CHN XXXX, CHP XXXX, CHQ XXXX, CHU XXXX, CHV XXXX, CHW XXXX, CHZ XXXX, CJA XXXX, CJD XXXX, CJE XXXX, CJK XXXX, CJP XXXX, CJQ XXXX, CJR XXXX, CJU XXXX, CJZ XXXX, CKA XXXX, CKC XXXX, CKD XXXX, CKE XXXX)	2
MEDIA-SK	Version of the Slovakian paper brand information  Only supports iR5075/5065/5055 Series V2. (BODY No. CHL XXXX, CHM XXXX, CHN XXXX, CHP XXXX, CHQ XXXX, CHU XXXX, CHV XXXX, CHW XXXX, CHZ XXXX, CJA XXXX, CJD XXXX, CJE XXXX, CJK XXXX, CJP XXXX, CJQ XXXX, CJR XXXX, CJU XXXX, CJZ XXXX, CKA XXXX, CKC XXXX, CKD XXXX, CKE XXXX)	2
MEDIA-TK	Version of the Turkish paper brand information  Only supports iR5075/5065/5055 Series V2. (BODY No. CHL XXXX, CHM XXXX, CHN XXXX, CHP XXXX, CHQ XXXX, CHU XXXX, CHV XXXX, CHW XXXX, CHZ XXXX, CJA XXXX, CJD XXXX, CJE XXXX, CJK XXXX, CJP XXXX, CJQ XXXX, CJR XXXX, CJU XXXX, CJZ XXXX, CKA XXXX, CKC XXXX, CKD XXXX, CKE XXXX)	2
MEDIA-CS	Version of the Czechoslovakian paper brand information  Only supports iR5075/5065/5055 Series V2. (BODY No. CHL XXXX, CHM XXXX, CHN XXXX, CHP XXXX, CHQ XXXX, CHU XXXX, CHV XXXX, CHW XXXX, CHZ XXXX, CJA XXXX, CJD XXXX, CJE XXXX, CJK XXXX, CJP XXXX, CJQ XXXX, CJR XXXX, CJU XXXX, CJZ XXXX, CKA XXXX, CKC XXXX, CKD XXXX, CKE XXXX)	2
MEDIA-EL	Version of the Greek paper brand information  Only supports iR5075/5065/5055 Series V2. (BODY No. CHL XXXX, CHM XXXX, CHN XXXX, CHP XXXX, CHQ XXXX, CHU XXXX, CHV XXXX, CHW XXXX, CHZ XXXX, CJA XXXX, CJD XXXX, CJE XXXX, CJK XXXX, CJP XXXX, CJQ XXXX, CJR XXXX, CJU XXXX, CJZ XXXX, CKA XXXX, CKC XXXX, CKD XXXX, CKE XXXX)	2



COPIER > DISPLAY > VERSION		
Sub-item	Description	Level
MEDIA-CA	Version of the Catalan paper brand information  Only supports iR5075/5065/5055 Series V2. (BODY No. CHL XXXX, CHM XXXX, CHN XXXX, CHP XXXX, CHQ XXXX, CHU XXXX, CHV XXXX, CHW XXXX, CHZ XXXX, CJA XXXX, CJD XXXX, CJJ XXXX, CJK XXXX, CJP XXXX, CJQ XXXX, CJR XXXX, CJU XXXX, CJZ XXXX, CKA XXXX, CKC XXXX, CKD XXXX, CKE XXXX)	2

&lt;ACC-ST&gt;

T-17-2

COPIER > DISPLAY > ACC-ST		
Sub-item	Description	Level
FEEDER	indicates the connection of an ADF. 0: not connected; 1: connected	1
SORTER	indicates the connection of the finisher and puncher unit. sorter type 0: none; 1: finisher; 2: saddle finisher; 3: shift tray punch type 0: none; 1: 2-hole; 2: 2/3-hole; 3: 4-hole (fr); 4: 4-hole (sw)	1
DECK	indicates the connection of a paper deck. 0: not connected; 1: connected	1
CARD	indicates the connection of a card reader. 0: card reader connected, but card not inserted 1: card reader not connected, or card reader connected and card inserted (with machine ready for copying, [1]; with machine not ready for copying, [0])	1
DATA-CON	indicates the connection of a copy data controller. 0: not connected; 1: connected	1
RAM	indicates the size of the memory mounted on the main controller PCB. 1024MB	1
COINROBO	indicates the connection of a coin vendor. 0: not connected; 1: connected	1
NIB	indicates the connection of a network board. 0: not connected 1: Ethernet board connected 2: TokenRing board connected 3: Ethernet board and TokenRing board connected	1
PS/PCL	indicates the presence/absence of PS/PCL firmware. 0: absent; 1: PS/PCL; 2: PS Kanji	1
RIP1	0: no; 1: yes	1
NETWARE	indicates the presence/absence of NetWare firmware. 0: absent; 1: present	1
PDL-FNC1	b31 : BDL b30 : PS b29 : PCL b28 : PDF b27 : LIPS b26 : N201 b25 : I5577 b24 : ESC/P b23 : HPGL b22 : HPGL2 b21 : IMAGING b20 : KS b19 : BMLinkS b18 to b16 : reserved (for possible addition of PDL)	1
PDL-FNC2	b15 to b0: reserved (for possible addition of PDL)	1
HDD	indicates the type name of the HDD.	1
PCII/2/3	indicates the board name of PCII/2/3. if not connected, indicates [-] (hyphen). if connected, indicates the board name. <Board Name> iSLTO: wireless LAN board Voice Board: voice guidance board 3DES+USB-HOST: security expansion board	1

&lt;ANALOG&gt;

T-17-3

COPIER > DISPLAY > ANALOG		
Sub-item	Description	Level
TEMP	indicates the machine inside temperature (environment sensor); in deg C	1
HUM	indicates the machine inside humidity (environment sensor); in % RH	1
ABS-HUM	indicates the moisture content (environment sensor); in g	1
FIX-U	fixing roller middle temperature (main thermistor, THM1) indicates the temperature of the middle of the fixing roller. between 0 and 255 deg C, in increments of 1 deg C	1

COPIER > DISPLAY > ANALOG		
Sub-item	Description	Level
FIX-UE	fixing roller edge temperature (sub thermistor, THM2) indicates the temperature of the edge of the fixing roller. between 0 and 255 deg C, in increments of 1 deg C	1
FIX-SHTR	fixing roller end temperature (shutter thermistor, THM3) indicates the temperature of the edge of the fixing roller. between 0 and 255 deg C.	1
CAP-VOL	indicates the voltage level of the charger unit [target product: only iR5075] settings range: 0 to 30 (unit: V) The setting for the product not targeted is "----".	1

<CST-ST>

T-17-4

COPIER > DISPLAY > CST-ST		
Sub-item	Description	Level
WIDTH-C3	indicates the width of paper in cassette 3 in terms of paper size; in mm.	2
WIDTH-C4	indicates the width of paper in cassette 4 in terms of paper size; in mm.	2
WIDTH-MF	indicates the width of paper in the manual feed tray; in mm.	2

<JAM>

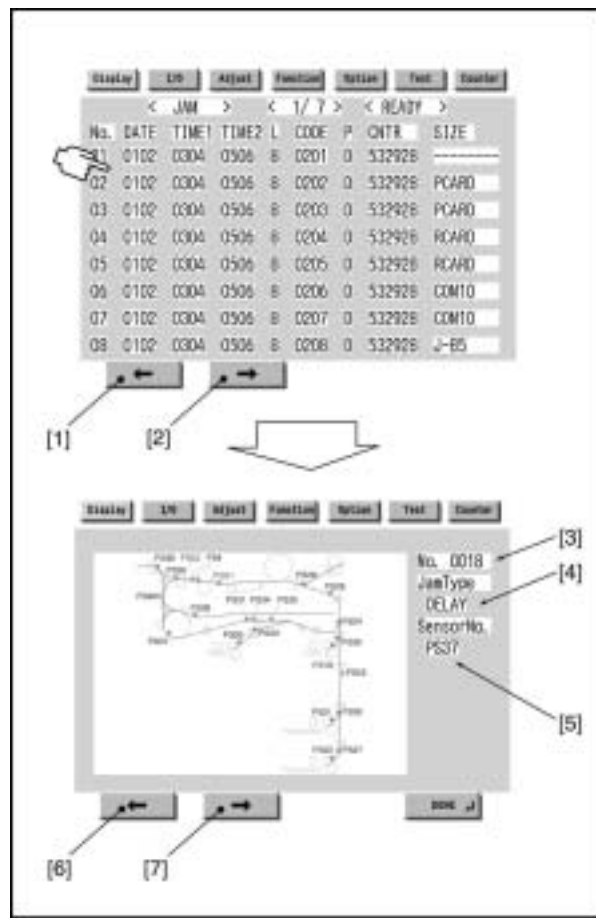

F-17-9

Touch the appropriate notation for details.

- [1] To go to the previous page.
- [2] To go to the next page.
- [3] To find out the order of jams.
- [4] To find out the type of jam.
- [5] To find the sensor in question.
- [6] To go to the previous Jam screen.
- [7] To go to the next Jam screen.

- <No.> Indicates the order of jams; 1 through 50 (the higher the number, the older the jam).
- <DATE> indicates the date of occurrence of the jam in question.
- <TIME1> indicates the time of occurrence of the jam in question.
- <TIME2> indicates the time of jam recovery.
- <L> indicates the location of the jam in question; 0 to 2 (0: copier; 1: feeder; 2: finisher).
- <CODE> indicates the jam code in question.
- <P> indicates the source of paper.
  - 1: cassette 1
  - 2: cassette 2
  - 3: cassette 3
  - 4: cassette 4

- 5: side paper deck
  - 6: manual feed tray
  - 7: duplexing assembly
- <CNTR> indicates the reading of the soft counter used for the source of paper.  
 <SIZE> indicates the size of paper.

## &lt;ERR&gt;

No.	DATE	TIME1	TIME2	CODE	DTL	L	P
01	---	---	---	---	---	---	---
02	0'02	0304	0506	E0708	090A	C	00
03	0'02	0304	0506	E0708	090A	C	00
04	0'02	0304	0506	E0708	090A	C	00
05	0'02	0304	0506	E0708	090A	C	00
06	0'02	0304	0506	E0708	090A	C	00
07	0'02	0304	0506	E0708	090A	C	00
08	0'02	0304	0506	E0708	090A	C	00

F-17-10

- <No.> indicates how recent the error in question is.  
 1 to 50 (the higher the number, the older the error)  
 <DATE> indicates the date of occurrence of the error in question.  
 <TIME1> indicates the time of occurrence of the error in question.  
 <TIME2> indicates the error recovery time.  
 <CODE> indicates the error code in question.  
 <DTL> indicates the detail code of the error in question. (if none, '0000')  
 <L> indicates the location of the error in question.  
 0: main controller  
 1: DADF  
 2: finisher  
 3: not used  
 4: reader unit  
 5: printer unit  
 6: PDL board  
 7: fax board  
 <P> not used

## &lt;HV-ST&gt;

T-17-5

COPIER > DISPLAY > HV-ST		
Sub-item	Description	Level
PRIMARY	primary charging current; in uA	1
PRE-TR	pre-transfer (post) current; in uA	1
TR	transfer current (1st side); in uA	1
SP	separation current (1st side); in uA	1
BIAS	developing bias output value DC component; in V	1
SP-N2	separation current (2nd side); in uA	1
TR-N2	transfer current (2nd side); in uA	1

## &lt;CCD&gt;

T-17-6

COPIER > DISPLAY > CCD		
Sub-item	Description	Level
TARGET-G	indicates the shading target value of green.	2
GAIN-OG	indicates the gain level adjustment value of green for CCD odd-numbered bits.	2
GAIN-EG	indicates the gain level adjustment value of green for CCD even-numbered bits.	2
GAIN-OR	indicates the gain level adjustment value of red for CCD odd-numbered bits.	2
GAIN-ER	indicates the gain level adjustment value of red for CCD even-numbered bits.	2

## &lt;DPOT&gt;

T-17-7

COPIER > DISPLAY > DPOT		
Sub-item	Description	Level
DPOT-K	COPIER>FUNCTION>DPC>OFST potential reflecting the value after execution; in V	1
VL1T	light-area potential target value; in V	1
VL1M	light-area potential measurement value; in V	1
VL2M	light-area potential measurement value for developing bias; in V	1
VDT	dark-area potential target value; in V	1

COPIER > DISPLAY > DPOT		
Sub-item	Description	Level
VDM	dark-area potential measurement value; in V	1
VL2M-P	light-area potential measurement value for developing bias for printer image; in V	1
VL1M-P	light-area potential measurement value for printer image; in V	1
VL1T-P	light-area potential target value for printer image; in V	1
VDM-P	light-area potential measurement value for printer image; in V	1
VDT-P	dark-area potential target value for printer image; in V	1
LLMT-P	laser output limit check for printer: 0: normal; 1: error	2
PLMT-P	primary charging current limit value setting for printer: 0: normal; 1: error	2
LLMT	laser power limit value setting: 0: normal; 1: error	2
PLMT	primary charging current limit value setting for copier: 0: normal; 1: error	2
BIAS-P	developing bias for printer (result of potential control); in V	2
BIAS-C	developing bias for copier (result of potential control); in V	2
LPOWER-P	laser output value for printer (result of potential control)	2
LPOWER-C	laser output value for copier (result of potential control)	2
PRIM-P	primary charging current value for printer (result of potential control); in uA	2
PRIM-C	primary charging current value for copier (result of potential control); in uA	2

## &lt;SENSOR&gt;

T-17-8

COPIER > DISPLAY > SENSOR		
Sub-item	Description	Level
DOC-SZ	indicates the size of the original identified by the original size sensor.	2

## &lt;MISC&gt;

T-17-9

COPIER > DISPLAY > MISC		
Sub-item	Description	Level
LPOWER	indicates the laser intensity (real-time)	2

## &lt;ALARM-2&gt;

No.	DATE	TIME1	TIME2	CODE	DTL	CNTR
01						
02						
03						
04						
05						
06						
07						
08						

F-17-11

<No.> indicates the order of alarm occurrence; between 1 and 50 (the higher the number, the older the alarm)

<DATE> date of occurrence of the alarm in question

<TIME1> time of occurrence of the alarm in question

<TIME2> time of alarm recovery

<CODE> code of alarm location and alarm code

<DTL> alarm detail code

<CNTR> reading of the total counter at time of alarm occurrence

## &lt;ENVRNT&gt;

- Environment Indication

The readings of the environment sensor and the fixing thermistor (main) are indicated as a history of changes in the following: machine inside temperature (deg C), humidity (%), fixing roller surface (middle; deg C).

No.	DATE	TIME	D+ deg C	E+ %	F+ deg C
001	0101	0000	0000	0000	0000
002	0201	0000	0000	0000	0000
003	0301	0000	0000	0000	0000
004	0401	0000	0000	0000	0000
005	0501	0000	0000	0000	0000
006	0601	0000	0000	0000	0000
007	0701	0000	0000	0000	0000
008	0801	0000	0000	0000	0000

F-17-12

T-17-10

Item	Description
No.	order of data acquisition (the higher the number, the older the data)
DATE	date of data acquisition
TIME	time of data acquisition
D + deg C	machine inside temperature
E + %	machine inside humidity
F + deg C	fixing roller surface (middle) temperature

**Memo:**

The interval at which data is acquired may be changed using the following service mode item: COPIER>OPTION>BODY>ENVP-IN.

**17.2.2 FEEDER****17.2.2.1 FEEDER List**

iR5065 / iR 5055 / iR5075 / iR5075N / iR5065N / iR5055N

T-17-11

COPIER > FEEDER > DISPLAY		
Sub-item	Description	Level
FEEDSIZE	indicates the size of the original identified by the feeder.	1
TRY-WIDE	indicates the distance between original width detecting slides (detecting the width of paper; 0.1 mm). indicates the distance between the slides used to detect the width of originals in the ADF original tray (between 2 points).	1
SPSN-LMN	post-separation sensor light emission level indicates the manual adjustment value (light-emission voltage) of the post-separation sensor. optimum range: 179 or lower	1
SPSN-RCV	post-separation sensor light reception level indicates the light reception value (of the post-separation sensor after manual adjustment). optimum range: paper present: 154 or lower paper absent: 179 or higher	1
RDSN-LMN	read sensor light emission level indicates the manual adjustment value (light emission voltage) of the read sensor. optimum range: 179 or lower	1
RDSN-RCV	read sensor light reception level indicates the light reception level of the read sensor after manual adjustment. optimum range: paper present: 154 or lower paper absent: 179 or higher	1
DRSN-LMN	delivery reversal sensor light emission level indicates the manual adjustment value (light emission voltage) of the delivery reversal sensor. optimum range: 905 or lower	1
DRSN-RCV	delivery reversal sensor light reception sensor level indicates the light reception voltage of the delivery reversal sensor after manual adjustment. optimum range: paper present: 154 or lower paper absent: 179 or higher	1

## 17.3 I/O (I/O Display Mode)

### 17.3.1 Outline

iR5065 / iR 5055 / iR5075 / iR5075N / iR5065N / iR5055N

The following provides a guide to the screen appearing in response to the following: COPIER>I/O.



F-17-13

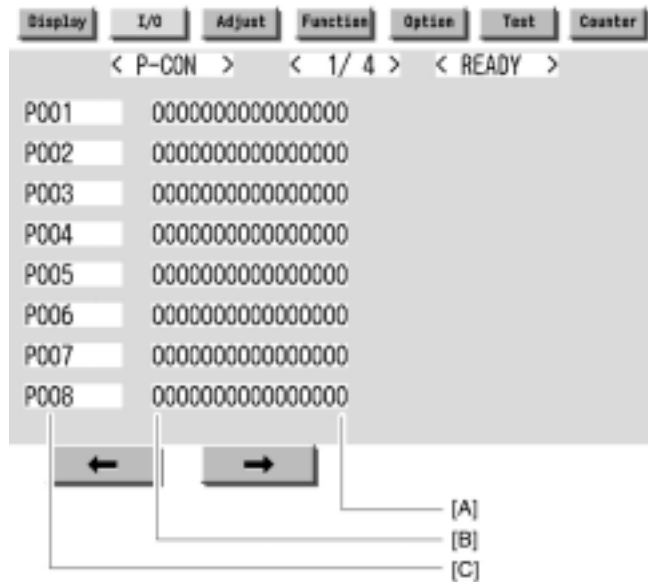

F-17-14

[A] bit 0  
 [B] bit 15  
 [C] address

### 17.3.2 R-CON

iR5065 / iR 5055 / iR5075 / iR5075N / iR5065N / iR5055N

T-17-12

Address	bit	Description	Remarks
P001	0	delivery motor CLK	
	1	DDIS IF (OPT00-)	0: prohibit operation
	2	DDIS IF (SPRDY)	0: permit operation
	3	DDIS IF (OPTI0)	0: active
	4	ADF pickup motor CLK	
	5	fan power supply ON signal	1: ON
	6	ADF read motor CLK	
	7	size sensor ON	1: ON



Address	bit	Description	Remarks
P002	0	shift motor CLK	
	1	24V power monitor	0: normal
	2-3	not used	
	4	scanner motor CLK	
	5	13V power supply monitor	0: normal
	6	Canon Electronics switchover	0: Canon Electronics
	7	DDIS IF (SCPRDY)	0: permit operation
P003	0	DDIS serial communication (TxD)	
	1	ADF serial communication (TxD)	
	2	DDIS serial communication (RxD)	
	3	ADF serial communication (RxD)	
	4	LED control	1: ON
	5	ADF serial communication (SCK)	
	6-7	not used	
P004	0	original size detection 0	0: original present
	1	original size detection 1	0: original present
	2	original size detection 2	0: original present
	3	original size detection 3	0: original present
	4	DF connection detection	
	5	DDIS IF (SRTS)	0: permit reception
	6	scanner motor Vref output	
	7	not used	
P005	0	PC connection IF (TxD)	
	1	PC connection IF (RxD)	
	2	fan lock detection signal	0: enable
	3	DDIS IF (SCTS)	0: permit reception
	4-7	not used	
P006	0	not used	
	1	PCB check terminal	1: normal
	2	DDIS IF (OPT11)	0: active
	3	DDIS IF (OPT01)	0: active
	4	ADF sensor interrupt input	0: active
	5	platen cover open/closed sensor interrupt input 0	1: cover open
	6	HP sensor interrupt input	1: HP
	7	not used	
P007	0	address bus 16	
	1	address bus 17	
	2	address bus 18	
	3-4	not used	
	5	ADF pickup motor clock interrupt input	
	6	ADF read motor clock interrupt input	
	7	ADF reversal motor clock interrupt input	
	P008	0	lamp ON signal
1		CCD drive ON signal	1: ON
2		wait signal	0: wait
3		L light signal	0: active
4		H light signal	0: active
5		read signal	0: active
6		ADF serial communication (LOAD)	0: enable
7		CPU click output	
P009	0	not used	
	1	shading RAM chip select	0: select
	2	work RAM chip select	0: select
	3	ASIC register chip select	0: select
	4	ROM chip select	0: select
	5-7	not used	

### 17.3.3 FEEDER

iR5065 / iR 5055 / iR5075 / iR5075N / iR5065N / iR5055N

T-17-13

Address	bit	Description	Remarks
P001	0	read sensor	0: paper present
	1	registration sensor	1: paper present
	2	delivery reversal sensor	0: paper present
	3	ADF cover open/closed sensor	0: ADF open
	4-7	not used	
P002	0	delivery motor current setting 1	
	1	deliver motor current setting 2	
	2	release motor current setting 1	
	3	release motor current setting 2	
	4	stamp solenoid drive	1: ON
	5	clutch drive	1: ON
	6	original detection LED	1: ON
	7	fan motor drive	1: ON
P003	0	pickup motor current setting CUT	
	1	feed motor current setting CUT	
	2	engagement motor current setting	
	3	feed motor mode setting	
	4	feed motor current setting 1	
	5	feed motor current setting 2	
	6	pickup motor current setting 1	
	7	pickup motor current setting 2	
P004	0	ADF cover open/closed sensor	0: ADF cover open
	1-6	not used	
	7	stamp present/absent	0: stamp present
P005	0	not used	
	1	release HP sensor	1: released
	2	delivery reversal sensor	0: paper present
	3	post-separation sensor	0: paper present
	4	LGL sensor	1: paper present
	5	AB/Inch check sensor	1: AB
	6	not used	
	7	original placement sensor	0: paper present
P006	0-7	for R&D	
P007	0-7	for R&D	
P008	0-7	for R&D	
P009	0-7	for R&D	
P010	0-7	for R&D	

### 17.3.4 SORTER

iR5065 / iR 5055 / iR5075 / iR5075N / iR5065N / iR5055N

T-17-14

Address	bit	Description	Remarks
P001	0	inlet feed motor phase A signal	
	1	inlet feed motor phase B signal	
	2	inlet feed motor phase A* signal	
	3	inlet feed motor phase B* signal	
	4	escape feed motor phase A signal	
	5	escape feed motor phase B signal	
	6	escape feed motor phase A* signal	
	7	escape feed motor phase B* signal	
P002	0	punch feed motor phase A signal	
	1	punch feed motor phase B signal	
	2	punch feed motor phase A* signal	
	3	punch feed motor phase B* signal	
	4	tray motor CLK signal	
	5	swing locking motor current switchover I0	0: ON
	6	swing locking motor phase A signal	
	7	swing locking motor phase B signal	

Address	bit	Description	Remarks
P003	0	TxD for external source	
	1	TxD for write	
	2	RxD for external	
	3	RxD for write	
	4	punch connection detection	0: connected
	5	OUT for punch communication	0: ON
	6-7	not used	
P004	0	escape feed motor CLK (IRQ0*)	
	1	not used	
	2	saddle connection detection	0: connected
	3	upper tray FG (IRQ3*)	
	4	swing lock HP sensor	1: HP
	5	not used	
	6	front cover open/closed sensor	0: open
P005	0	TxD for punch communication	
	1	RxD punch for punch communication	
	2	IN for punch communication (IRQ2*)	0: ON
	3-7	not used	
P006	1	lower tray motor LOCK	0: locked
	2	not used	
	3	lower tray motor ON	0: ON
	4	not used	
	5	motor standby signal	0: ON
	6	not used	
	7	not used	
P007	0-7	not used	
P008	0	lower tray area sensor 1	0: detected
	1	lower tray area sensor 2	0: detected
	2	lower tray area sensor 3	0: detected
	3	not used	
	4	punch feed motor CLK (IRQ4*)	
	5	lower tray FG (IRQ5*)	
	6	inlet feed motor lock input (IRQ6*)	
7	stack edging motor clock input (IRQ7*)		
P009	0	inlet sensor	1: paper present
	1	lower tray paper surface sensor	0: paper present
	2	1700-sheet paper surface sensor	0: paper present
	3	upper tray interlock	1: error
	4	upper tray area sensor 1	0: detected
	5	upper tray area sensor 2	0: detected
	6	upper tray area sensor 3	0: detected
7	not used		
P010	0	inlet feed motor current switch I1	0: ON
	1	inlet feed motor current switch I0	0: ON
	2	punch feed motor current switch I1	0: ON
	3	punch feed motor current switch I0	0: ON
	4	punch feed motor standby	0: ON
	5	escape feed motor I0	0: ON
	6	escape feed motor I1	0: ON
7	escape feed motor standby	0: ON	
P011	0	upper tray motor CW/CCW	1: CCW/0: CW
	1	upper tray motor ON	0: ON
	2	upper tray motor LOCK	0: locked
	3	solenoid ON signal	0: ON
	4-5	not used	
	6	lower tray motor CW/CCW	1: CCW/0: CW
	7	delivery path sensor	1: paper present
P012	0	inlet roller shift solenoid	1: ON
	1	buffer roller shift solenoid	1: ON
	2	expansion IO chip select signal (CS2*)	
	3	IPC chip select (CS3*)	
	4-7	not used	

Address	bit	Description	Remarks
P013	0	gear change motor phase A signal	
	1	gear change motor phase B signal	
	2	gear change motor current switch I0	0: ON
	3	gear change motor current switch I1	0: ON
	4	escape flapper solenoid ON signal	1: ON
	5	EEPROM output signal	
	6	EEPROM enable signal	
P014	7	EEPROMCLK	
	0	EEPROM input signal	
	1	aligning plate FHP sensor	1: HP
	2	aligning plate RHP sensor	1: HP
	3	handling tray paper sensor	1: paper present
	4	trailing edge assist HP sensor	1: HP
	5	for machine download	
P015	6-7	not used	
	0	aligning plate R motor phase A signal	
	1	aligning plate R motor phase B signal	
	2	aligning plate R motor current switch I0	0: ON
P016	3-7	not used	
	0	aligning plate F motor phase A signal	
	1	aligning plate F motor phase B signal	
	2	aligning plate F motor current switch I0	0: ON
P017	3-7	not used	
	0	trailing edge assist motor phase A signal	
	1	trailing edge assist motor phase B signal	
	2	trailing edge assist motor current switch I0	0: ON
	3	trailing edge assist motor current switch I1	0: ON
	4	trailing edge assist motor standby signal	0: ON
P018	5-7	not used	
	0	stapler shift motor standby signal	0: ON
	1	stapler motor direction switch CCW	1: ON
	2	stapler motor direction switch CW	1: ON
	3	not used	
	4	stapler shift motor phase A signal	
	5	stapler shift motor phase B signal	
P019	6-7	not used	
	0	escape tray path sensor	1: paper present
	1	escape tray full sensor	1: full
	2	stapler HP detection	1: HP
	3	stapler READY	1: ready
	4	stapler LS	1: staple present
	5	escape feed upper cover sensor	1: close
	6	stapler shift HP sensor	1: HP
P020	7	stapler alignment interference sensor	1: interference
	0	stapler shift motor current switch I0	0: ON
	1	stapler shift motor current switch I1	0: ON
	2	No. 1 delivery motor shift solenoid	1: ON
	3	buffer trailing edge retaining solenoid	1: ON
	4	stack edging lower roller clutch	1: ON
	5	shutter open/close clutch	1: ON
	6	stack edging motor current switch I1	0: ON
P021	7	stack edging motor current switch I0	0: ON
	0	stack feeding motor phase A signal	
	1	stack edging motor phase B signal	
	2	stack feeding motor phase A* signal	
	3	stack edging motor phase B* signal	
	4	upper tray paper surface sensor	1: paper present
	5	stapler interlock	1: open
P021	6	shutter HP sensor	1: HP
	7	swing guide interlock	1: open

Address	bit	Description	Remarks
P022	0	DIPSW_8	0: ON
	1	DIPSW_7	0: ON
	2	DIPSW_6	0: ON
	3	DIPSW_5	0: ON
	4	DIPSW_4	0: ON
	5	DIPSW_3	0: ON
	6	DIPSW_2	0: ON
P023	7	DIPSW_1	0: ON
	0	PUSHSW1	0: ON
	1	PUSHSW2	0: ON
	2	PUSHSW	0: ON
	3	upper tray paper sensor	0: paper present
	4	lower tray paper sensor	0: paper present
	5	24V detection	0: detected
	6	front cover interlock	1: open
P024	7	fan error detection	0: detected
	0	fan ON signal	1: ON
	1	LED1	0: ON
	2	LED2	0: ON
	3	LED3	0: ON
	4	X4-POWER-ON signal	0: ON
P025	5-7	not used	
	0	saddle guide motor phase A signal	
	1	saddle guide motor phase B signal	
	2	saddle guide motor current switch I0	0: ON
	3	saddle feed motor current switch I0	0: ON
	4	saddle feed motor phase A signal	
	5	saddle feed motor phase B signal	
	6	saddle feed motor phase A* signal	
P026	7	saddle feed motor phase B* signal	
	0	saddle alignment motor phase A signal	
	1	saddle alignment motor phase B signal	
	2	saddle alignment motor current switch I0	0: ON
	3	saddle paper positioning motor current switch I0	0: ON
	4	saddle paper positioning motor phase A signal	
	5	saddle paper position motor phase B signal	
	6	solenoid PWM	
P027	7	saddle folding motor PWM	
	0	trimmer PICKUP-TxD	
	1	TxD for write	
	2	trimmer CPU-RxD	
	3	RxD for write	
	4	trimmer OUT	0: ON
	5	trimmer connection detection	0: detected
	6-7	not used	
P028	0	saddle front stapling current detection	1: detected
	1	saddle rear stapling current detection	1: detected
	2	saddle delivery door connection detection	1: detected
	3-5	not used	
	6	saddle stapler unit connection detection	1: detected
	7	not used	
	P029	0	saddle rear staple detecting switch
1		saddle front staple detecting switch	0: detected
2		saddle front stapler CCW	0: ON
3		stapler feed motor standby	0: ON
4-7		not used	
P030	0-1	not used	
	2	saddle folding motor FWD (CW)	1: ON
	3	saddle folding motor RV (CCW)	1: ON
	4	saddle folding CLK sensor (IRQ0*)	
	5	saddle butting CLK sensor (IRQ1*)	
	6	saddle rear stapler HP sensor (IRQ2*)	1: HP
	7	saddle front stapler HP sensor (IRQ3*)	1: HP

Address	bit	Description	Remarks
P031	0	saddle position HP sensor	0: HP
	1	saddle guide HP sensor	1: HP
	2	inlet cover sensor	1: close
	3	saddle stapler unit sensor	0: detected
	4	saddle butting HP sensor (IRQ4*)	1: HP
	5	saddle butting TOP sensor (IRQ5*)	1: butting position
	6	trimmer IN (IRQ6*)	0: ON
	7	saddle feed motor CLK (IRQ7*)	
P032	0	saddle tray paper sensor	0: paper present
	1	positioning plate paper sensor	0: paper present
	2	saddle crescent roller sensor	0: HP
	3	saddle delivery sensor	0: paper present
	4	saddle trailing edge sensor 1	1: detected
	5	saddle trailing edge sensor 2	1: detected
	6	saddle trailing edge sensor 3	1: detected
	7	saddle path sensor	1: detected
P033	0	saddle butting motor EN	1: ON
	1	saddle butting motor FWD (CW)	1: ON
	2	saddle butting motor RV (CCW)	1: ON
	3	saddle folding HP sensor	0: HP
	4	not used	
	5	saddle delivery sensor	0: paper present
	6	saddle aligning plate HP sensor	0: HP
	7	not used	
P034	0	saddle inlet solenoid	1: ON
	1	saddle No. 1 flapper solenoid	1: ON
	2	saddle No. 2 flapper solenoid	1: ON
	3	saddle pickup solenoid	1: ON
	4-6	not used	
	7	saddle inlet sensor	1: detected
P035	0	saddle rear stapler CW (CW)	0: ON
	1	saddle rear stapler CCW (CCW)	0: ON
	2	saddle front stapler CW (CW)	0: ON
	3	chip select (CS1*)	
	4-7	not used	
P036	0	DIPSW_1	0: ON
	1	DIPSW_2	0: ON
	2	DIPSW_3	0: ON
	3	DIPSW_4	0: ON
	4	DIPSW_5	0: ON
	5	DIPSW_6	0: ON
	6	DIPSW_7	0: ON
	7	DIPSW_8	0: ON
P037	0	not used	
	1	PUSHSW1	0: ON
	2	5V detection signal	0: detected
	3	24V detection signal	0: detected
	4	for revision control	
	5	for revision control	
	6	for revision control	
	7	for revision control	
P038	0	download ON signal	1: ON
	1	not used	
	4	LED3	0: ON
	5	LED2	0: ON
	6	LED1	0: ON
	7	power-on signal	0: ON
P039	0	DIPSW1	0: ON
	1	DIPSW2	0: ON
	2	DIPSW3	0: ON
	3	not used	
	4	PCH-OUT	
	5	trailing edge sensor	1: ON
	6	punch encoder lock	
	7	punch HP sensor	0: detected

Address	bit	Description	Remarks
P040	0	PCH-IN	
	1	RxD	
	2	TxD	
	3-7	not used	
P041	0	EEPROM-IN	
	1	EEPROM-OUT	
	2	EEPROM-CLK	
	3	EEPROM-CS	
	4	horizontal registration HP sensor	1: ON
	5	horizontal registration motor STB	0: ON
	6	punch motor CCW	0: ON
	7	punch motor CW	0: ON
P042	0-3	not used	
	4	DIPSW4	0: ON
	5	horizontal registration motor CUR	0: ON
	6	PWM	
	7	not used	
P043	0	LED1	0: ON
	1	horizontal registration motor INA	
	2	horizontal registration motor INB	
	3	LED2	0: ON
	4	front cover sensor	0: close
	5	BOOTMODE	
	6	PUSHSW2	0: ON
	7	PUSHSW1	0: ON
P044	0-4	not used	
	5	upper cover sensor	1: open
	6-7	not used	
P045	ADDR A	not used	
P046	ADDR B	not used	
P047	AD0	trailing edge sensor	
P048	AD1	B5R sensor	
P049	AD2	A4R sensor	
P050	AD3	B4 sensor	
P051	AD6	dust sensor	
P052	AD7	A3 sensor	

### 17.3.5 MN-CON

iR5065 / iR 5055 / iR5075 / iR5075N / iR5065N / iR5055N

not used

### 17.3.6 P-CON

iR5065 / iR 5055 / iR5075 / iR5075N / iR5065N / iR5055N

T-17-15

Address	bit	Description	Remarks
P001	0	manual feed paper sensor signal	0: paper present
	1	registration paper sensor signal	1: paper present
	2	right deck retry sensor signal	1: paper present
	3	cassette 3 paper sensor signal	1: paper present
	4	vertical path 3 paper sensor signal	1: paper present
	5	cassette 4 paper sensor signal	1: paper present
	6	vertical path 4 paper sensor signal	1: paper present
	7	right deck paper sensor signal	1: paper present
	8	vertical path 1 paper sensor signal	1: paper present
	9	left deck paper sensor signal	1: paper present
	10	vertical path 2 paper sensor signal	1: paper present
	11	outside delivery sensor signal	1: paper present
	12	inside delivery paper sensor signal	0: paper present
	13	not used	
	14	claw jam sensor signal	0: paper present
15	left deck pull-off detection signal	1: paper present	

Address	bit	Description	Remarks
P002	0	cassette 3 retry sensor signal	1: paper present
	1	cassette 4 retry sensor signal	1: paper present
	2	left deck retry sensor signal	1: paper present
	3	reversal sensor 1 signal	1: paper present
	4	right deck limit sensor	1: paper present
	5	duplexing pre-registration signal	1: paper present
	6	duplexing horizontal registration sensor signal	0: paper present
	7	reversal sensor 2 signal	1: paper present
	8	write check sensor signal	1: paper present
	9	developing assembly toner sensor signal	0: toner low
	10	hopper toner sensor signal	0: toner low
	11	duplexing paper sensor signal	1: paper present
	12	fixing web length detection signal	1: web absent
	13	fixing output sensor signal	0: paper present
	14	shutter HP signal	0: HP/set position
	15	collecting toner feedscrew signal	0: lock
P003	0	developing clutch ON signal	1:ON
	1	left deck pull-off clutch ON signal	1:ON
	2	manual feed pickup clutch ON signal	1:ON
	3	AKM_EX_CLK_ENABLE signal	
	4	roller bias ON signal	0:ON
	5	developing AC bias ON signal	0:ON
	6	high-voltage high-humidity switchover signal	0:ON
	7	high-voltage AC ON signal	0:ON
	8	charger unit operation mode 1	
	9	not used	
	10	charger unit operation mode 2	
	11	not used	
	12	high-voltage remote signal	0:ON
	13	EEPROM select signal 1	1:ON
	14	EEPROM select signal 2	1:ON
15	EEPROM select signal 3	1:ON	
P004	0	cassette 3 size detection signal 0	
	1	cassette 3 size detection signal 1	
	2	cassette 4 size detection signal 0	
	3	cassette 4 size detection signal 1	
	4	fixing shutter thermistor overheating detection signal	1: overheating
	5	fixing sub thermistor overheating detection signal	1: overheating
	6	fixing main thermistor overheating detection signal	1: overheating
	7	accessories power supply fan stop detection signal	1: stop
	8	not used	
	9	HVT cooling fan stop detection signal	1: stop
	10	circulation duct fan stop detection signal	1: stop
	11	hopper toner sensor connection detection signal	0: connected
	12	developing toner sensor connection detection signal	0: connected
	13	shutter set detection signal	0:HP
	14	relay OFF detection signal	1:OFF
15	fixing inlet guide solenoid connection detection signal	1: not connected	
P005	0	separation fan stop detection signal	1: stop
	1	primary charging cooling fan stop detection signal	1: stop
	2	DC power supply fan stop detection signal	1: stop
	3	heat discharge fan stop detection signal	1: stop
	4	fixing heater power supply fan stop detection signal	1: stop
	5	controller fan stop detection signal	1: stop
	6	duplexing feed fan stop detection signal	1: stop
	7	curl-removing fan stop detection signal	1: stop
	8	right deck paper level sensor (upper) signal	1: paper present
	9	left deck paper level sensor (upper) signal	1: paper present
	10	duplexing unit detection signal	0: present
	11	fixing/feed unit detection signal	0: present
	12	right deck paper level sensor (lower) signal	1: paper present
	13	left deck paper level sensor (lower) signal	1: paper present
	14	charger unit operation status 1	
15	fixing web solenoid connection detection signal	1: not connected	



Address	bit	Description	Remarks
P006	0	fixing motor lock detection signal	1: locked
	1-6	not used	
	7	hopper MERR	1: error
	8	bottle MERR	1: error
	9	not used	
	10	bottle motor connection detection signal	0: connected
	11	shift tray full sensor signal	0: full
	12	shift tray paper sensor signal	0: paper present
	13	shift tray HP sensor L signal	1:HP
	14	shift tray HP sensor R signal	1:HP
P007	15	shift tray connector detection signal	0: connected
	0-7	not used	
	8	fixing inlet sensor signal	1: paper present
	9	delivery jam sensor signal	1: jam
	10	IH-PID0	0:ON
	11	IH-PID1	0:ON
	12	high-voltage separation error signal	0: error
	13	high-voltage transfer error signal	0: error
P008	14	high-voltage primary charging error signal	0: error
	15	12V monitor signal	0:12V ON
	0	manual feed door open/closed sensor signal	0: line
	1	right deck paper level sensor signal	1: paper present
	2	right deck pull-off sensor signal	1: paper present
	3	left deck paper level sensor signal	1: paper present
	4	left deck limit sensor signal	1: paper present
	5	cassette 3 paper level sensor signal	1: paper present
	6	cassette 4 paper level sensor signal	1: paper present
	7	not used	
	8	cassette 3 open/closed sensor signal	0: open
	9	cassette 4 open/closed sensor signal	0: open
	10	registration clutch ON signal	0:ON
	11	right deck open/closed sensor signal	0: open
	12	left deck open/closed signal	0: open
P009	13	lower right door open/closed sensor signal	0: open
	14	bottle cover sensor signal	0: open
	15	front door open/closed sensor signal	1: open
	0	shift tray connection detection signal	1: not connected
	1	shift tray motor (CCW) signal	0:ON
	2	shift tray motor (CW) signal	0:ON
	3	right deck pickup solenoid ON signal	0:ON
	4	left deck solenoid ON signal	1:ON
	5	cassette 3 solenoid ON signal	1:ON
	6	cassette 4 solenoid ON signal	1:ON
	7	manual feed holding plate release solenoid ON signal	1:ON
	8	motor enable signal	1:ENABLE
	9	reversing flapper 1 solenoid ON signal	1:ON
	10	reversing flapper 2 solenoid ON signal	0:ON
	11	fixing inlet guide solenoid ON signal (return)	1: ON (guide at low)
P010	12	fixing inlet guide solenoid ON signal (suction)	1: ON (guide at up)
	13	fixing web solenoid ON signal	1:ON
	14	drum heater relay SET signal	1:ON
	15	drum heater delay RESET signal	1:ON
	0	right deck lifter motor ON signal	0:ON
	1	left deck lifter motor ON signal	0:ON
	2	primary charging wire cleaning motor (CCW) signal	1:ON
	3	primary charging wire cleaning motor (CW) signal	1:ON
4	pre-transfer charging wire cleaning motor (CCW) signal	1:ON	
5	pre-transfer charging wire cleaning motor (CW) signal	1:ON	
6	transfer/separation charging wire cleaning motor (CCW) signal	1:ON	
7	transfer/separation charging wire cleaning motor (CW) signal	1:ON	

Address	bit	Description	Remarks
P011	0	drum motor ON signal	0:ON
	1	main motor ON signal	0:ON
	2	cassette heater ON signal	0:ON
	3	not used	
	4	sensor 5V power supply	
	5	bottle stirring motor ON signal	0:ON
	6	hopper stirring motor 2 ON signal	0: forward/1: reverse
P012	7	circulation duct fan (half-speed) ON signal	1: forward/0: reverse
	0	circulation duct fan (half-speed) ON signal	1:ON
	1	circulation duct fan (full-speed) ON signal	1:ON
	2	drum heater ON signal	0:ON
	3	power supply fan ON signal	0:ON
	4-5	not used	
	6	cassette 4 lifter motor ON signal	0:ON
P013	7	cassette 3 lifter motor ON signal	0:ON
	0	separation feed fan (half-speed) ON signal	1:ON
	1	separation feed fan (full-speed) ON signal	1:ON
	2	primary charging cooling fan (half-speed) ON signal	1:ON
	3	primary charging cooling fan (full-speed) ON signal	1:ON
	4	HVT cooling fan (half-speed) ON signal	1:ON
	5	HVT cooling fan (full-speed) ON signal	1:ON
P014	6	lower fan (half-speed) ON signal	1:ON
	7	lower fan (full-speed) ON signal	1:ON
	0	IH power supply cooling fan (half-speed) ON signal	1:ON
	1	IH power supply cooling fan (full-speed) ON signal	1:ON
	2	controller cooling fan (half-speed) ON signal	1:ON
	3	controller cooling fan (full-speed) ON signal	1:ON
	4	not used	
P015	5	duplexing feed fan (full-speed) ON signal	0:ON
	6	curl-removing fan (half-speed)	1:ON
	7	curl-removing fan (full-speed)	1:ON
	0	relay shut OFF signal	1:OFF
	1	accessories power supply fan (half-speed) ON signal	1:ON
	2	accessories power supply fan (full-speed) ON signal	1:ON
	3	counter (total)	1:ON
P016	4	not used	
	5	pre-exposure LED ON signal	1:ON
	6	potential sensor ON signal	1:ON
	7	12V release signal	1:ON
	0	DDI-PPRDY	
	1	DDI-CTS	
	2	DDI-PO0	
P017	3	DDI-PO1	
	4	DDI-PO2	
	5	DDI-PO3	
	6	DDI-PO4	
	7	DDI-PO5	
	0	DDI-CPRDY	
	1	DDI-PRSST	
P018	2	DDI-RST	
	3	DDI-PI0	
	4	not used	
	5	DDI-PI2	
	6	DDI-PI3	
	7	DDI-PI4	
	P018	0	jam detection port
1		IMGON_FLG	
2-7		not used	

Address	bit	Description	Remarks
P019	0	not used	
	1	reversal motor clock signal	
	2-4	not used	
	5	duplexing left feed motor clock signal	
	6	not used	
	7	delivery motor clock signal	
P020	0	registration clutch ON signal	
	1-4	not used	
	5	pre-registration motor clock signal	
	6	not used	
	7	duplexing right feed motor clock signal	
P021	0	not used	
	1	DDI-TxD	
	2	not used	
	3	DDI-RxD	
	4	DDI-POWER	
	5	DDI-SCNST	
	6-7	not used	
P022	0-7	not used	
P023	0	FIN-RESET	
	1	FIN-MODE	
	2-7	not used	
P024	0-4	not used	
	5	pulse count INT	
	6	DMA-END-INT	
	7	DMA-REQ-INT	
P025	0	deck open detecting switch signal	0: closed
	1	deck paper absent sensor signal	1: paper present
	2	deck lifter upper limit sensor signal	1: upper limit
	3	deck pickup sensor signal	1: paper present
	4	deck feed sensor signal	1: paper present
	5	deck pickup clutch ON signal	1:ON
	6	not used	
7	deck paper supply position sensor signal	1:ON	
P026	0	deck paper level sensor signal	1: paper present
	1	deck lifter lower limit detection signal	1: lower limit
	2	deck set sensor signal	1: connected
	3	deck open sensor signal	1: closed
	4	deck ID1	1: connected
	5	deck ID2	0: connected
	6	not used	
	7	switchover of the large/small deck	
P027	0	deck open LED ON signal	1:ON
	1	deck pickup roller release solenoid drive signal	1:ON
	2	not used	
	3	deck pickup clutch drive signal	1:ON
	4-5	not used	
	6	deck main motor drive signal	1:ON
	7	deck lifter motor drive signal	1:ON
P028	0	deck lifer lower limit detection signal	1:ON
	1	deck open solenoid	1:ON
	2	deck main motor constant current setting	1:ON
	3-7	not used	

## 17.4 ADJUST (Adjustment Mode)

### 17.4.1 COPIER

#### 17.4.1.1 COPIER List

iR5065 / iR 5055 / iR5075 / iR5075N / iR5065N / iR5055N

<AE>

## T-17-16

COPIER > ADJUST > AE		
Sub-item	Description	Level
AE-TBL	adjustment range: 1 to 9 (default: 5) - to obtain darker characters, increase the setting. - to obtain lighter characters, decrease the setting. If you have initialized the RAM on the reader controller PCB, enter the value indicated on the service label.	1

## &lt;ADJ-XY&gt;

## T-17-17

COPIER > ADJUST > ADJ-XY		
Sub-item	Description	Level
	Use it to adjust the image read start position. - If you have initialized the RAM on the reader controller PCB or replaced the PCB, enter the value indicated on the service label. - If you have changed the setting of this item, record the new setting on the service label.	
ADJ-X	Use it to adjust the image read start position (X direction). adjustment range: 1 to 100 (default: 26)	1
ADJ-Y	Use it to adjust the image read start position (Y direction). adjustment range: 200 to 500 (default: 352)	1
ADJ-Y-DF	Use it to adjust the main scanning position for feeder mode. adjustment range: 100 to 400 (default: 248)	1
STRD_POS	Use it to adjust the CCD read position for DF stream reading mode. adjustment range: 1 to 200 (default: 100)	1
ADJ-X-MG	Fine adjustment of magnification in sub scanning direction at copyboard reading adjustment range: -50 to 50 (default: 0)(unit: 0.01%)	1
ADJ-Y-DF2	Adjustment of the position on the backside in main scanning direction at simultaneous double-sided reading adjustment range: 21 to 106 (default: 76)	1

## &lt;CCD&gt;

## T-17-18

COPIER > ADJUST > CCD		
Sub-item	Description	Level
SH-TRGT	Use it to enter the white level target value for shading correction. adjustment range: 1 to 2047 (default: 1136)	1
DFTAR-G	Use it to adjust the shading target value for green for DF mode. adjustment range: 1 to 2047 (default: 1189)	1
MTF-M1	Setting value of front/back matching MTF in main scanning direction (front). adjustment range: 20 to 80 (default: 50)	1
MTF-M2	Setting value of front/back matching MTF in main scanning direction (center). adjustment range: 20 to 80 (default: 50)	1
MTF-M3	Setting value of front/back matching MTF in main scanning direction (back). adjustment range: 20 to 80 (default: 50)	1
MTF-S1	Setting value of front/back matching MTF in sub scanning direction. adjustment range: 20 to 80 (default: 50)	1
DFCH2G2	Setting of linearity characteristic data value of No. 2 data (Green) of DF composite chart for CCD. adjustment range: 1 to 2550 (default: 2000)	1
DFCH2G10	Setting of linearity characteristic data value of No. 10 data (Green) of DF composite chart for CCD. adjustment range: 0 to 2550 (default: 0)	1
DFCH-G10	Setting of linearity characteristic data value of No. 10 data (Green) of DF composite chart for CIS. adjustment range: 0 to 2550 (default: 0)	1
DFCH-G2	Setting of linearity characteristic data value of No. 2 data (Green) of DF composite chart for CIS. adjustment range: 1 to 2550 (default: 2000)	1

## &lt;LASER&gt;

## T-17-19

COPIER > ADJUST > LASER		
Sub-item	Description	Level
PVE-OFST	Use it to adjust the laser write start position. adjustment range: -300 to 300	1
POWER	Use it to adjust the laser power (for non-potential control). adjustment range: 0 to 255	1

## &lt;DEVELOP&gt;

## T-17-20

COPIER > ADJUST > DEVELOP		
Sub-item	Description	Level
BIAS	Use it to adjust the developing bias (for non-potential control). adjustment range: 0 to 600 (default: 180)	1
HVT-DE	Use it to enter an offset value for the high-voltage unit. adjustment range: -100 to 100 (default: 0)	1
D-HV-DE	Use it to enter the offset value for the high-voltage D/A output for the DC controller PCB. adjustment range: -50 to 50 (default: 0)	1
TSPLY-ADJ	Use it to adjust the toner supply distribution (axial direction) for the developing assembly. adjustment range: 1 to 5 (default: 3)	2

&lt;DENS&gt;

## T-17-21

COPIER > ADJUST > DENS		
Sub-item	Description	Level
DENS-ADJ	Use it to adjust the density of images (copier/printer). Use it to correct the F-value table in the event of fading in a high-density area or fogging in an image. adjustment range: 1 to 9 (default: 5) - to decrease fading, increase the value. - to decrease fogging, decrease the value. If you have initialized the RAM on the DC controller PCB, enter the value indicated on the service label.	1

&lt;BLANK&gt;

## T-17-22

COPIER > ADJUST > BLANK		
Sub-item	Description	Level
BLANK-T	Use it to enter the image leading edge non-image width. adjustment range: 1 to 500 (default: 94) If you have initialized the RAM on the DC controller PCB or replaced the PCB, enter the value indicated on the service label.	1
BLANK-B	Use it to enter the image trailing edge non-image width. adjustment range: 0 to 2362 (default: 47) If you have initialized the RAM on the DC controller PCB or replaced the PCB, enter the value indicated on the service label.	1

&lt;V-CONT&gt;

## T-17-23

COPIER > ADJUST > V-CONT		
Sub-item	Description	Level
EPOTOFST	Use it to enter the potential offset value. adjustment range: 0 to 255 (default: 0)	1
VL-OFST	Use it to enter the light-area target potential offset adjustment value. adjustment range: -5 to 5 (default: 0)	1
VD-OFST	Use it to enter the dark-area target potential offset adjustment value. adjustment range: -5 to 5 (default: 0)	1
DE-OFS-P	Use it to enter the offset value of the back contrast for printer images. adjustment range: -50 to 50 (default: 0)	1
VD-OFS-P	Use it to enter the target VD offset value for printer images. adjustment range: -5 to 5 (default: 0)	1
DE-OFST	Use it to enter the target D offset value for copier images. adjustment range: -50 to 50 (default: 0)	1
VL-OFS-P	Use it to enter the target VL offset value for printer images. adjustment range: -50 to 50 (default: 0)	1

&lt;HV-PRI&gt;

## T-17-24

COPIER > ADJUST > HV-PRI		
Sub-item	Description	Level
PRIMARY	Use it to enter the current setting of the primary charging assembly. settings range: 0 to 1400 (default: 771)	1

&lt;HV-TR&gt;

## T-17-25

COPIER > ADJUST > HV-TR		
Sub-item	Description	Level
TR-N1	Use it to adjust the output level of the 1st side of plain paper for an N/N environment. adjustment range: 100 to 400 (default: 380)	1
TR-N2	Use it to adjust the output level of the 2nd side for an N/N environment. adjustment range: 100 to 400 (default: 310)	1
PRE-TR	Use it to adjust the current level of the pre-transfer charging assembly. adjustment range: -300 to 0 (default: -70)	1
HVT-TR	Use it to enter the transfer charging assembly high-voltage offset value for the high-voltage unit. adjustment range: -100 to 100 (default: 0)	1
H-PRE-TR	Use it to enter the pre-transfer charging assembly high-voltage offset value for the high-voltage unit. adjustment range: -100 to 100 (default: 0)	1
D-PRE-TR	Use it to enter the pre-transfer charging assembly high-voltage offset value for the DC controller PCB. adjustment range: -50 to 50 (default: 0)	1
D-HV-TR	Use it to enter the transfer charging assembly high-voltage offset value for the DC controller PCB. adjustment range: -50 to 50 (default: 0)	1

&lt;HV-SP&gt;

## T-17-26

COPIER > ADJUST > HV-SP		
Sub-item	Description	Level
SP-N1	Use it to adjust the output level for the 1st side of plain paper for an N/N environment. adjustment range: -500 to 100 (iR5075 default: -240) (iR5055/5065 default: -175)	1
SP-N2	Use it to adjust the output level for the 2nd side of plain paper for an N/N environment. adjustment range: -500 to 100 (iR5075 default: -120) (iR5055/5065 default: -100)	1
HVT-SP	Use it to enter the separation charging assembly high-voltage offset level for the high-voltage unit. adjustment range: -100 to 100	1
D-HV-SP	Use it to enter the separation charging assembly high-voltage offset value for the DC controller PCB. adjustment range: -50 to 50	1

&lt;FEED-ADJ&gt;

## T-17-27

COPIER > ADJUST > FEED-ADJ		
Sub-item	Description	Level
REGIST	Use it to adjust the leading edge registration. adjustment range: -50 to 50	1
ADJ-REFE	Use it to adjust the horizontal registration for duplex mode. adjustment range: -50 to 50	1
RG-MF	Use it to adjust the registration for manual pickup. adjustment range: -50 to 50	1

&lt;CST-ADJ&gt;

## T-17-28

COPIER > ADJUST > CST-ADJ		
Sub-item	Description	Level
C3-STMTR	Use it to enter the paper width basic value for cassette 3 (STMTR). adjustment range: 0 to 255	1
C3-A4R	Use it to enter the paper width basic value for cassette 3 (A4R). adjustment range: 0 to 255	1
C4-STMTR	Use it to enter the paper width basic value for cassette 4 (STMTR). adjustment range: 0 to 255	1
C4-A4R	Use it to enter the paper width basic value for cassette 4 (A4R). adjustment range: 0 to 255	1

COPIER > ADJUST > CST-ADJ		
Sub-item	Description	Level
MF-A4R	Use it to enter the paper width basic value for the manual feed tray (A4R). adjustment range: 0 to 255	1
MF-A6R	Use it to enter the paper width basic value for the manual feed tray (A6R). adjustment range: 0 to 255	1
MF-A4	Use it to enter the paper width basic value for the manual feed tray (A4). adjustment range: 0 to 255	1
C3-LVOL	Use it to enter the capacity of the cassette 3 (50 sheets). adjustment range: 0 to 255	1
C3-HVOL	Use it to enter the capacity of the cassette 3 (275 sheets). adjustment range: 0 to 255	1
C4-LVOL	Use it to enter the capacity of the cassette 4 (50 sheets). adjustment range: 0 to 255	1
C4-HVOL	Use it to adjust the capacity of the cassette 4 (275 sheets). adjustment range: 0 to 255	1

&lt;MISC&gt;

T-17-29

COPIER > ADJUST > MISC		
Sub-item	Description	Level
ATM	Use it to make settings related to the atmospheric pressure of the site of installation. settings range: 0 to 2 (default: 0) 0: 1 to 0.75 atm (up to elevation of 2500 m) 1: 0.75 to 0.70 atm (elevation between 2500 and 300 m) 2: 0.70 to 0.65 atm (elevation between 300 and 3500 m)	1

## 17.4.2 FEEDER

### 17.4.2.1 FEEDER List

iR5065 / iR 5055 / iR5075 / iR5075N / iR5065N / iR5055N

T-17-30

COPIER > FEEDER > ADJUST		
Sub-item	Description	Level
DOCST	Use it to adjust the original image leading edge position. - a higher setting will delay the timing for the image leading edge. adjustment range: -50 to 50 (unit: 0.1 mm)	1
LA-SPEED	Use it to adjust the original feed speed in feeder stream reading mode. - a higher setting will increase the speed (i.e., contracts the image). adjustment range: -30 to 30 (unit: 0.1%)	1
DOCST2	Adjustment of VYSNC timing on the backside of the feeder at simultaneous double-sided reading. adjustment range: -50 to 50 [default: 0] (unit: 0.1mm)	1
LA-SPEED2	Use it to adjust the sub scanning magnification in feeder back stream reading mode for duplex simultaneous reading.(for fine adjustment of HSYNC length) adjustment range: -120 to 120 [temporary] (unit: 0.1%)	1

## 17.4.3 SORTER

### 17.4.3.1 SORTER List

iR5065 / iR 5055 / iR5075 / iR5075N / iR5065N / iR5055N

T-17-31

COPIER > SORTER > ADJUST		
Sub-item	Description	Level
PNCH-HLE	Use it to adjust the length from the edge of paper to the punch hole. settings range: -4 to 2 (unit: mm)	1

## 17.5 FUNCTION (Operation/Inspection Mode)

### 17.5.1 COPIER

#### 17.5.1.1 COPIER List

iR5065 / iR 5055 / iR5075 / iR5075N / iR5065N / iR5055N

&lt;INSTALL&gt;

COPIER > FUNCTION > INSTALL		
Sub-item	Description	Level
TONER-S	Use it to stir the toner inside the developing assembly at time of installation. Procedure 1. Select the item to highlight. 2. See that the message "Check the developer" is indicated. At this time, check to see that the developing assembly is correctly mounted. 3. Press the OK key to start the operation. The operation will automatically stop after a specific period of time. during operation, time remaining (sec): at the end, if successful, '0'; if error, '0xFFFF'.	1
CARD	Use it to set up the card reader. Procedure Enter the number of a specific card (0 to 2001), and press the OK key. (As many as 100 cards may be used, starting from the number you have entered.) At this time, initialization will take place for card control information (group ID and ID No.).	1
E-RDS	Use it to specify the use of E-RDS. 0: off (do not use; default) 1: use RDS (transmit all counter information)	1
RGW-PORT	Use it to set the Sales Company server port number used for embedded-RDS. settings range: 1 to 6535	1
COM-TEST	Use it to check the connection to the server used for E-RDS. Procedure 1) Select the item to highlight, and press the OK key. 2) See where a connection has been made. (The result will be indicated as 'OK' or 'NG'.) OK: connection possible; NG: connection not possible	1
COM-LOG	Use it to indicate the details of the result of the communication test executed for the server used for E-RDS. Procedure 1) Select the item to highlight, and press [show info]. log information particulars: year, date, time, error code, error detail (128 characters max.)	1
RGW-ADR	Use it to specify the URL of the server used for E-RDS. Procedure 1) Select the item to highlight, and press [show information]. 2) When the URL input screen appears, enter the appropriate URL and press the OK key. (default: https://a01.ugwdevice.net/ugw/agnetif010)	1
STRD-POS	Use it to adjust the face (CCD) read position for DADF stream reading mode. settings range: 1 to 200 [default: 100] (unit: 0.1 mm)	1
CNT-DATE	Setting of the start date to send counter information to the server. Set the start date to send counter information to the server by the third party advanced function for Embedded-RDS (eRDS). [Remarks] This mode is displayed only when the third party advanced function for eRDS is available. Setting range: YYYY: year, MM: month, HH: hour, MM: minute Factory setting value: 000000000000 (12 digits: YYYYMMDDHHMM)	1
CNT-INTV	Setting of the interval to send counter information to the server. Set the interval to send counter information to the server by the third party advanced function for Embedded-RDS (eRDS). [Remarks] This mode is displayed only when the third party advanced function for eRDS is available. Setting range: 1 to 168 (for a week) Factory setting value: 24	1

&lt;CCD&gt;

COPIER > FUNCTION > CCD		
Sub-item	Description	Level
CCD-ADJ	Use it to execute CCD auto adjustment. Procedure 1) Place about 10 sheets of paper (the whitest of all papers used by the user, other than color print paper) on the platen glass. 2) Select <CCD-ADJ> to highlight, and press the OK key. 3) See that auto adjustment takes place (about 15 sec). During adjustment, <ACTIVE> will be indicated. 4) See that the scanning lamp goes on twice during adjustment. At the end, the screen will show <OK!>. 5) See that all items of service mode have been updated (COPIER>ADJUST>CCD). Record the new settings on the service label.  If you have replaced the CCD unit, scanning lamp, inverter PCB, or platen board glass (standard white plate), be sure to execute this mode item.	1



COPIER > FUNCTION > CCD		
Sub-item	Description	Level
<b>DF-WLVL1/2</b>	Use it to execute ADF white level adjustment (platen board scan/stream reading scan) Procedure 1) Place a sheet of paper (of the type most frequently used by the user) on the platen board glass, and execute the following: COPIER>FUNCTION>CCD>DF-WLVL1. The white level for book mode is read (checking the degree of transmission of the glass for book mode). 2) Place a sheet of paper often used by the user in the DF, and execute the following: COPIER>FUNCTION>CCD>DF-WLVL2. The white level for DF mode (stream reading) is read (checking the degree of transmission of glass for stream reading; reading both sides of the chart). face: computes DFTAR-R/G/B back: computes DFTAR2-R/G/B  Caution: Be sure to execute both of the foregoing 2 items at the same time.	1
<b>LUT-ADJ</b>	start-ups the reading sequence for CCD seam correction data (gray plate scanning) [not operating in this machine]	1
<b>DF-LNR</b>	Start of calculation of gain offset for front/back matching from DF composite chart reading data (No. 2 and No. 10) By executing this mode after setting the reading data of No. 2 and No. 10 of DF composite chart to perform matching of difference in front/back density to "ADJUST>CCD>DFCH_XX", linearity characteristics are calculated and a setting value is determined.	1
<b>MTF-CLC</b>	Calculate the MTF filter count which is actually set to ASIC based on the MTF value. Calculate the MTF filter count which is actually set to ASIC based on the MTF value specified for each CCD/CIS in COPIER>ADJUST>CCD>MTF-M1 to 3, MTF-S1.	1
<b>LUT-ADJ2</b>	start-ups the reading sequence for CCD seam correction data 2 (DS chart)	2

&lt;LASER&gt;

T-17-34

COPIER > FUNCTION > LASER		
Sub-item	Description	Level
<b>POWER</b>	Use it to turn on the laser for laser power adjustment. Procedure 1) Select the item to highlight, and press the OK key. 2) See that the laser goes on. 3) See that the laser goes off in about 30 sec. (To turn it off in the middle, press the Stop key.)	1

&lt;DPC&gt;

T-17-35

COPIER > FUNCTION > DPC		
Sub-item	Description	Level
<b>DPC</b>	Use it to force the execution of potential control. The machine is designed so that it will not perform potential control at power-on (recovery mode) if the temperature of the fixing assembly is 70 deg C or higher. If you have replaced the photosensitive drum or the laser unit, or if you have changed the drum potential setting, be sure to execute this mode item. Procedure 1) Select the item, and type in '1'; then, press the OK key. 2) Turn off and then on the main power switch. 3) See that the machine executes potential control and stops it automatically.	1
<b>OFST</b>	Use it to adjust the offset value of the potential sensor. This mode item is part of the series of procedures you have to perform when you have replaced the potential sensor unit. Be sure never to execute it on its own. Procedure 1) Select the item to highlight, and press the OK key. 2) See that the machine executes offset adjustment and stops it automatically.	1

&lt;CST&gt;

## T-17-36

COPIER > FUNCTION > CST		
Sub-item	Description	Level
<b>C3-STMTR</b> <b>C3-A4R</b> <b>C4-STMTR</b> <b>C4-A4R</b>	Use it to register the paper width basic value of the cassette 3/4. STMTR width: 139.5 mm; A4R width: 210 mm To make fine adjustments after registering a value, use the following: ADJUST>CST-ADJ>C3-STMTR, C3-A4R, C4-STMTR, C4-A4R. Procedure 1) Put STMTR paper in the cassette, and adjust the slide guide plate to the width. 2) Select C3-STMTR (C4-STMTR) to highlight, and press the OK key so that the machine executes auto adjustment and register the value. 3) Likewise, repeat steps 1) and 2) to register the basic value for A4R.	1
<b>MF-A4R</b> <b>MF-A6R</b> <b>MF-A4</b>	Use it to register the paper width basic value for the manual feed tray. A4R width: 210 mm; A6R: 105 mm; A4 width: 297 mm To make fine adjustments after registering a basic value, use the following: COPIER>ADJUST>CST-ADJ>MF-A4R, MF-A6R, MF-A4. Procedure 1) Put A4R paper in the manual feed tray, and adjust the size guide to the width. 2) Select MF-A4R to highlight, and press the OK key so that the machine executes auto adjustment and register the value. 3) Likewise, repeat steps 1) and 2) for A6R and A4.	1

## &lt;CLEANING&gt;

## T-17-37

COPIER > FUNCTION > CLEANING		
Sub-item	Description	Level
<b>WIRE-CLN</b>	Clean all charging wires 5 times (5 trips) all at the same time. Procedure 1) Select the item to highlight, and press the OK key. 2) See that the notation changes to 'ACTIVE', indicating that the charging wires are being cleaned. 3) See that the machine stops cleaning automatically. (To stop in the middle, press the OK key.)	1

## &lt;FIXING&gt;

## T-17-38

COPIER > FUNCTION > FIXING		
Sub-item	Description	Level
<b>NIP-CHK</b>	Use it to generate printouts for automatic measurement of the fixing nip width. Procedure 1) Make about 20 A4 prints. 2) Put A4 plain or recycled paper in the manual feed tray. 3) Select the item to highlight, and press the OK key. 4) See that the paper is picked from the manual feed tray, held in the fixing nip area, and discharged in about 20 sec. 5) Check the nip width of the discharged paper: if b is from 4.5 to 6.5 mm, the nip may be considered normal. In the event of a fixing fault or wrinkling and if the difference between the front b and the rear c is appreciable, go to step 6) to make adjustments. 6) Tighten the screw found on the side with the narrower nip; then, loosen the other screw to the same degree (so that the nip width is identical between front and rear).	1

## &lt;PANEL&gt;

## T-17-39

COPIER > FUNCTION > PANEL		
Sub-item	Description	Level
<b>LCD-CHK</b>	Use it to check for missing dots in the LCD. Procedure 1) Select the item, and press the OK key to start. See that the front of the touch panel starts to go on in the following order: white, black, red, green, blue. 2) Press the Stop key to end the operation.	1
<b>LED-CHK</b>	Use it to check the activation of the LEDs on the control panel. Procedure 1) Select the item, and press the OK key to start. See that the LEDs go on in sequence. 2) Press [LED-off] to end the operation.	1
<b>LED-OFF</b>	Check the LEDs on the control panel. Procedure 1) Select the item to end the operation for LED-CHK.	1

COPIER > FUNCTION > PANEL		
Sub-item	Description	Level
<b>KEY-CHK</b>	Use it to check the key inputs. Procedure 1) Select [KEY-CHK] so that the numbers and names of input keys appear. 2) Check a key to check. If normal, its corresponding character will appear on the touch panel. (See the table.) 3) Select [KEY-CHK] to end the ongoing check.	1
<b>TOUCHCHK</b>	Use it to adjust the coordinates of the analog touch panel. Procedure - Use it to match a specific point of the touch panel and its coordinates on the LCD. - If you have replaced the LCD assembly, be sure to execute this service mode item. 1) Select [TOUCH CHECK] to highlight, and press the OK key. 2) Press the 9 + symbols that appear on the touch panel to make adjustments.	1

## Numbers and Names of Input Keys

T-17-40

Key	Indication on screen
0 to 9,#,*	0 to 9,#,*
Reset	RESET
Stop	STOP
User mode	USER
Start	START
Clear	CLEAR
ID	ID
Help	?
Counter Check	BILL

## &lt;PART-CHK&gt;

T-17-41

COPIER > FUNCTION > PART-CHK		
Sub-item	Description	Level
CL	Use it to select a clutch whose operation you want to check. (range: 1 to 5) Procedure 1) Select the item. 2) Using the keypad, type in the code of the clutch. 3) Press the OK key. 4) Press [CL-on] to check the operation.	1
CL-ON	Use it to start a check on the clutch. Procedure 1) Select an item, and press the OK key so that the clutch will repeatedly go on and off as follows: for 0.5 sec, on -> for 10 sec, off -> for 0.5 sec, on -> for 10 sec, off -> for 0.5 sec, on -> off.	1
MTR	Use it to select the motor whose operation you want to check. (range: 1 to 30) Procedure 1) Select the item, and press the OK key so that the motor will repeatedly go on and off as follows: for 0.5 sec, on -> for 10 sec, off -> for 0.5 sec, on -> for 10 sec, off -> for 0.5 sec, on -> off.	1
MTR-ON	Use it to start the operation of the motor. Procedure 1) Select the item, and press the OK key so that the motor will repeatedly go on and off as follows: - for 20 sec on -> off - the hopper stirring motor and horizontal registration motor: for 10 sec, on -> off - shift tray motor: stops at front/rear HP  Be sure to remove the toner bottle before checking the operation of the bottle motor (MTR=22); otherwise, the toner is likely to spill out inside the machine.	1
SL	Use it to select the solenoid whose operation you want to check. (range: 1 to 11) Procedure 1) Select the item. 2) Type in the code of the solenoid using the keypad. 3) Press the OK key. 4) Press [SL-on] to check the operation.	1
SL-ON	Use it to start the operation of the solenoid. 1) Select the item, and press the OK key so that the solenoid will repeatedly go on and off as follows: for 0.5 sec, on -> for 10 sec, off -> for 0.5 sec, on -> for 10 sec, off -> for 0.5 sec, on -> off.	1

T-17-42

## - Clutch

Code	Name
1	manual feed d pickup clutch (CL3)
2	left deck pull-off clutch (CL4)
3	side deck pickup clutch (CL102)
4	developing clutch (CL1)
5	registration roller clutch (CL2)

T-17-43

## - Motor

Code	Name
1	laser scanner motor (M22)
2	drum motor (M1)
3	main motor (M2)
4	fixing motor (M3)
5	right deck pickup motor (M11)
6	left deck pickup motor (M24)
7	cassette 3/4 pickup motor (M12)
8	vertical path duplexing feed motor (M25)
9	vertical path lower motor (M27)
10	vertical path upper motor (M26)
11	side deck main motor (M101)
12	reversal motor (M14)
13	duplexing feed right motor (M18)
14	delivery motor (M13)
15	pre-registration motor (M17)
16	duplexing feed left motor (M19)
17	primary charging wire cleaning motor (M6)
18	pre-transfer charging wire cleaning motor (M7)
19	transfer/separation charging wire cleaning motor (M8)
20	hopper stirring motor (M9); CW rotation (feed/stirring)
21	hopper stirring motor (M9); CCW rotation (stirring)
22	bottle motor (M10) be sure to remove the toner bottle before starting a check.
23	duplexing horizontal registration motor (M16)
24	shutter motor (M15)
25	right deck lifter motor (M4)
26	left deck lifter motor (M5)
27	cassette 3 lifter motor (M20)
28	cassette 4 lifter motor (M21)
29	side deck lifter motor (M102)
30	shift tray motor (SM101)

T-17-44

## - Solenoid

Code	Name
1	right deck pickup solenoid (SL6)
2	left deck pickup solenoid (SL7)
3	cassette 3 pickup solenoid (SL3)
4	cassette 4 pickup solenoid (SL4)
5	manual feed release solenoid (SL2)
6	deck pickup roller release solenoid (SL101)
7	delivery flapper solenoid (SL5)
8	reversing flapper solenoid (SL8)
9	fixing inlet guide drive solenoid (SL1); plunger returned
10	fixing inlet guide drive solenoid (SL1); plunger drawn
11	fixing web solenoid (SL9)

&lt;CLEAR&gt;

COPIER > FUNCTION > CLEAR		
Sub-item	Description	Level
<b>ERR</b>	Use it to reset an error code. (codes: E000, E001, E002, E003, E004, E005) Procedure 1) Select the item, and press the OK key. 2) Turn off and then on the main power.	1
<b>DC-CON</b>	Use it to initialize the RAM on the DC controller PCB. The RAM will be initialized when the main power switch is turned off and then back on. Procedure 1) Print out the service mode particulars using the following: COPIER>FUNCTION>MISC-P>P-PRINT. 2) Select the item, and press the OK key. 3) Turn off and then on the main power switch. 4) As necessary, enter the data you have printed using P-PRINT.	1
<b>R-CON</b>	Use it to initialize the RAM on the reader controller PCB. The settings will be initialized when you turn off and then on the main power switch. Procedure 1) Print out the service mode particulars using the following: COPIER>FUNCTION>MISC-P>P-PRINT. 2) Select the item, and press the OK key. 3) Turn off and then back on the main power. 4) As necessary, enter the data you have printed using P-PRINT.	1
<b>JAM-HIST</b>	Use it to reset the jam history. The jam history will be reset when the OK key is pressed. Procedure 1) Select the item, and press the OK key.	1
<b>ERR-HIST</b>	Use it to reset the error code history. The error code will be reset when the OK key is pressed. 1) Select the item, and press the OK key.	1
<b>PWD-CLR</b>	Use it to reset the password of the system administrator. The password of 'system administrator' set in user mode is reset when the OK key is pressed. Procedure 1) Select the item, and press the OK key.	1
<b>ADRS-BK</b>	Clearing the address book. The address book is cleared when the main power switch is turned OFF and ON.	1
<b>CNT-MCON</b>	Use it to reset the service counter whose reading is kept by the main controller PCB. The counter reading is reset when the OK key is pressed. Procedure 1) Select the item, and press the OK key.	1
<b>CNT-DCON</b>	Use it to reset the service counter whose reading is kept by the DC controller PCB. The counter reading will be reset when the OK key is pressed. Procedure 1) Select the item, and press the OK key.	1
<b>OPTION</b>	Use it to reset the service mode setting OPTION to its default setting (as upon RAM initialization). The setting will be initialized when the OK key is pressed. The execution of this item will reset the data kept by the main controller, DC controller, and reader controller. Procedure 1) Print out the service mode particulars using the following: COPIER>FUTON>MISC-P>P-PRINT. 2) Select the item, and press the OK key.	1
<b>MMI</b>	Use it to reset the following settings of user mode: - backup user data for copier control panel (user settings) - common settings backup data (user settings) - various backup data except FAX data (sure settings) The settings will be initialized when the main power switch is turned off and then back on. Procedure 1) Select the item, and press the OK key. 2) Turn off and then back on the main power.	1
<b>MN-CON</b>	Use it reset the RAM on the main controller PCB. The RAM will be reset when the main power switch is turned off and then back on. Procedure 1) Print out the service mode particulars using the following: COPIER>FUNCTION>MISC-P>P-PRINT. 2) Select the item, and press the OK key. 3) Turn off and then back on the main power. 4) As necessary, enter the data you have printed out using P-PRINT.	1
<b>CARD</b>	Use it to reset the data related to card ID (group). The card ID-related data will be reset when the main power switch is turned off and then back on. Procedure 1) Select the item, and press the OK key. 2) Turn off and then back on the main power.	1

COPIER > FUNCTION > CLEAR		
Sub-item	Description	Level
<b>ALARM</b>	Use it to reset the alarm log. The alarm log will be reset when the main power switch is turned off and the back on. Procedure 1) Select the item, and press the OK key. 2) Turn off and then back on the main power.	1
<b>LANG-ERR</b>	Clear the language-related error. Use this mode to recover from an error when a language-related error occurs after the language setting is changed from the default. (The setting is returned to the default value after recovery.)	1
<b>DF-RCON</b>	Initialize the backup data of DF-RCON board (EEPROM) Clear the EEPROM value used to maintain backup data installed in DF-RCON and initialize the data.	1
<b>SND-STUP</b>	Use it to reset the transmission read settings. The transmission read settings will be reset when the main power switch is turned off and then back on. Procedure 1) Select the item, and press the OK key. 2) Turn off and then back on the main power.	2
<b>CA-KEY</b>	Use it to reset the CA certificate and key. The CA certificate and the key will be reset when the main power switch is turned off and then back on. Procedure 1) Select the item, and press the OK key. 2) Turn off and then back on the main power.	2
<b>KEY-CLR</b>	Clear the encryption key for the HDD encryption board. Clear the key to replace the encryption key in the HDD encryption board (security kit). Select KEY-CLR and press the OK key to clear the encryption key. When turning off/on the main power after performing this operation, the encryption board installation process operates, and a new encryption key is generated. Note) When this operation is performed, all the data in HDD become unavailable. Therefore, when turning off/on the main power after performing this operation, it is necessary to start from formatting of HDD.	2

## &lt;MISC-R&gt;

T-17-46

COPIER > FUNCTION > MISC-R		
Sub-item	Description	Level
<b>SCANLAMP</b>	Use it to turn on the scanning lamp. Procedure 1) Select the item. 2) Press the OK key so that the scanning lamp goes on and remains on for 3 sec.	1

## &lt;MISC-P&gt;

T-17-47

COPIER > FUNCTION > MISC-P		
Sub-item	Description	Level
<b>P-PRINT</b>	Use it to print out service mode settings. Procedure 1) Select the item. 2) Press the OK key to generate a printout.	1
<b>USER-PRT</b>	Use it to print out user mode settings. Procedure 1) Select the item. 2) Press the OK key to generate a printout.	1
<b>PRE-EXP</b>	Checking the pre-exposure lamp (LED). 1) Select the item to highlight. 2) Press the OK key to execute various operations for several seconds. The operation will stop automatically. (full activation) 3) Press the OK key to generate a printout. Reference If the photosensitive drum suffers a fault as the result of lamp activation, rotate the drum.	1
<b>D-PRINT</b>	Use it to print out service mode settings (DISPLAY). The settings under DISPLAY will be printed (not including P-PRINT, LBL-PRINT, HIST-PRINT and ALARM). Procedure 1) Select the item. 2) Press the OK key to generate a printout.	1

COPIER > FUNCTION > MISC-P		
Sub-item	Description	Level
ENV-PRT	Use it to print out a log of changes in the machine inside temperature/humidity and in fixing temperature. The log will show changes in the machine inside temperature/humidity and in fixing temperature (center) collected from the monitor outputs of the non-contact thermistor and the environment sensor. 1) Select the item. 2) Press the OK key to generate a printout.	1
KEY-HIST	Use it to print out the history of control panel key inputs. 1) Select the item. 2) Press the OK key to generate a printout.	1
TRS-DATA	Transition of memory reception data. Transmit the memory reception data to the data BOX. Operation Method: 1) Select the item. 2) Press [OK] so that the data is transmitted.	1
LBL-PRNT	Print the service label. Print the description on the service label. Operation Method: 1) Set an A4/LTR in Cassette 1. 2) Select the item. 3) Press [OK] so that the label is printed. It will take about 15 sec to start printing.	1
HIST-PRT	Use it to print out the jam history and the error history. Procedure 1) Select the item. 2) Press the OK key to generate a printout.	2

## &lt;SENS-ADJ&gt;

T-17-48

COPIER > FUNCTION > SENS-ADJ		
Sub-item	Description	Level
STCK-LMT	Use it to adjust the position of the shift tray full sensor. If the tray is full, 'on' will be indicated; if empty, 'off' will be indicated.	2

## &lt;SYSTEM&gt;

T-17-49

COPIER > FUNCTION > SYSTEM		
Sub-item	Description	Level
DOWNLOAD	Use it to switch to download mode. Procedure 1) Select the item. 2) Press the OK key to start download mode.	1
CHK-TYPE	Use it to select the appropriate partition number for execution of HD-CHECK or HD-CLEAR. Procedure 1) Select the item. 2) Select the number of the partition you want using the keypad. 0: entire HDD (*1, *2) 1: image storage area 2: general-purpose file (user settings data, log data, PDL spool data) storage area 3: PDL-related file storage area 4: firmware storage area (*1, *2) 5: MEAP area 6: address book area (*1)  *1: cannot be initialized using HD-CLEAR. *2: can be initialized using the SST.	1
HD-CHECK	Use it to check and recover the partition you have selected using CHK-TYPE. procedure 1) Select the item. 2) Press the OK key. 3) See the result. (1: OK; 2: NG (hardware); 3: NG (software) (recovery sector/substitute sector also indicated))	1
HD-CLEAR	Use it to initialize the partition you have selected using CHK-TYPE. Procedure 1) Select the item. 2) Press the OK key.	1

COPIER > FUNCTION > SYSTEM		
Sub-item	Description	Level
DEBUG-1	Specify the type of logs to be saved and the timing to save them in HDD. Setting value: 0 to 3 (Default: 0) MEMO: -This mode is not used in regular service. (This mode is used to analyze causes of troubles.) -Follow an instruction of Quality Support Div. when using this mode.  Setting range: 0: Save PLOG at the timing when Reboot/Exception is detected. 1: Save PLOG at the timing when Reboot/Exception/Ecode is detected. 2: Save SUBLOG at the timing when Reboot/Exception/Ecode is detected. 3: Save SUBLOG in overwriting mode at the timing when Reboot/Exception/Ecode is detected. Factory setting value: 0	2
DEBUG-2	Print out logs saved in HDD. Print out PLOG data which is saved when "0" or "1" is specified for COPIER>FUNCTION>SYSTEM>DEBUG-1. [Remarks] SUBLOG data saved when "2" or "3" is specified for COPIER>FUNCTION>SYSTEM>DEBUG-1 is not printed out.  Number of printouts: Approximately 20 printouts in A4 size	2

## 17.5.2 FEEDER

### 17.5.2.1 FEEDER List

iR5065 / iR 5055 / iR5075 / iR5075N / iR5065N / iR5055N

T-17-50

COPIER > FEEDER > FUNCTION		
Sub-item	Description	Level
SENS-INT	Use it to adjust the sensitivity of individual sensors of the ADF. Be sure to clean the sensor area before executing the item. Procedure 1) Select the item, and press the OK key. 2) See that the execution ends automatically.	1
MTR-CHK	Use it to check the ADF motor on its own. Procedure 1) Press MTR-CHK to highlight. 2) Type in the appropriate motor number using the keypad. 3) Press the OK key. 4) Press MTR-on to start the check. Motor Number 0: pickup motor 1: feed motor Adjustment range: 0 to 4	1
TRY-A4	Use it to execute automatic adjustment of paper width detection reference point 1 of the ADF original pickup tray. (A4)	1
TRY-A5R	Use it to execute automatic adjustment of paper width detection reference point 2 of the ADF original pickup tray. (A5R)	1
TRY-LTR	Use it to execute automatic adjustment of paper width detection reference point 1 of the ADF original pickup tray. (LTR)	1
TRY-LTRR	Use it to execute automatic adjustment of paper width detection reference point 2 of the ADF original pickup tray. (LTRR)	1
FEED-CHK	Use it to check paper movement in the ADF on its own. Procedure 1) Press FEED-CHK to highlight. 2) Type in the appropriate paper feed mode using the keypad. 3) Press the OK key. 4) Press FEED-on to check the operation. Paper Feed Mode Number 0: simplex pickup delivery operation 1: duplex pickup delivery operation 2: simplex pickup delivery operation (w/ stamp) 3: duplex pickup delivery operation (w/ stamp)	1
CL-CHK	Use it to check the ADF clutch on its own. Procedure 1) Press CL-CHK to highlight. 2) Type in the appropriate clutch number. 3) Press the OK key. 4) Press CL-on to check the operation. Clutch Number 0: pickup clutch	1



COPIER > FEEDER > FUNCTION		
Sub-item	Description	Level
CL-ON	Use it to start the operation of the clutch. Procedure 1) Press CL-on and then the OK key to start the operation of the clutch. 2) Press the OK key once again to stop the operation. (The operation will stop automatically in about 2 sec; however, the indication will not change to 'STOP' unless you press the OK key.)	1
FAN-CHK	Use it to check the ADF cooling fan on its own. Procedure 1) Press FAN-CHK to highlight. 2) Type in the fan number using the keypad. 3) Press the OK key. 4) Press FAN -on to check the operation. Fan Number 0, 1: cooling fan Adjustment range: 0 to 2	1
FAN-ON	Use it to start fan operation. Procedure 1) Press FN-on and then the OK key to start the operation of the fan. 2) Press the OK key to stop the operation. (The fan will stop automatically in about 5 sec; however, the indication will not be 'STOP' unless the OK key is pressed.)	1
SL-CHK	Use it to check the ADF solenoid on its own. Procedure 1) Press SL-CHK to highlight. 2) Type in the solenoid number using the keypad. 3) Press the OK key. 4) Press SL-on to check the operation. Solenoid Number 0: locking solenoid 1: stamp solenoid	1
SL-ON	Use it to start the operation of the solenoid. Procedure 1) Press SL to highlight and then the OK key to start the operation of the motor. 2) Press the OK key once again to stop the operation. (The operation will stop automatically in about 5 sec; however, the indication will not be 'STOP' unless the OK key is pressed once again.)	1
MTR-ON	Use it to start the operation of the motor. Procedure 1) Press MTR-on to highlight and then the OK key to start the operation of the motor. 2) Press the OK key once again to stop the operation. (The operation will stop automatically in about 5 sec; however, the indication will not be 'STOP' unless the OK key is pressed.)	1
ROLL-CLN	ADF Roller Cleaning Mode Execute the mode so that the motor will rotate the roller. Force lint-free paper moistened with alcohol against the roller to clean it. Procedure 1) Press ROLL-CLN to highlight. 2) While the roller is rotating, force lint-free paper moistened with alcohol against the roller to clean. 3) Select ROLL-CLN to highlight and press the OK key so that the roller will stop.	1
FEED-ON	Use it to check the movement of paper in the ADF on its own. Procedure 1) Press FEED-on and then the OK key so that paper movement will start according to the operation mode selected using FEED-CHK.	1

## 17.6 OPTION (Machine Settings Mode)

### 17.6.1 COPIER

#### 17.6.1.1 COPIER List

iR5065 / iR 5055 / iR5075 / iR5075N / iR5065N / iR5055N

<BODY>

T-17-51

COPIER > OPTION > BODY		
Sub-item	Description	Level
PO-CNT	Use it to turn on and off the potential control mechanisms. setting: 0: off; 1: on (default)	1

COPIER > OPTION > BODY		
Sub-item	Description	Level
<b>MODEL-SZ</b>	Use it to switchover the default magnification ratios and ADF original size detection. 0: AB (6R5E) 1: inch (5R4E) 2: A (3R3E) 3: AB/inch (6R5E)	1
<b>FIX-TEMP</b>	Use it to select down sequence mode. 0: normal 1: standard + 10 deg C (default) 2: standard - 5 deg C	1
<b>FUZZY</b>	Use it to turn on and off fuzzy control and to set the environment. 0: enable fuzzy control (default) 1: fix to low humidity environment mode (current level lower than standard) 2: fix to normal temperature/humidity mode 3: fix to high humidity mode (current level higher than standard)	1
<b>CONFIG</b>	Use it to select multiple firmware items stored on the hard disk and switchover country, language, machine type, and paper size configuration. Procedure XXYYZZ XX: country (JP); YY: language (ja); ZZ (00): machine type; AA (00): paper size configuration. The indications will be in keeping with the following: COPIER>DISPLAY>USER>LANGUAGE. (The notations in parentheses indicate defaults. The country and language notations are for indication only.) 1) Select <CONFIG>. 2) Select the appropriate item to highlight, and press the +/- key. 3) See that each press on the +/- key changes the selections in sequence. 4) When you have made all selections, press the OK key. 5) Turn off and then on the main power switch.	1
<b>TR_SP_C1</b>	Use it to change the transfer/separation output settings when the right deck is used as the source of paper by way of providing a remedial measure. Setting 0: normal (default); 1: separation fault; 2: double transfer; 3: transfer fault	1
<b>TR_SP_C2</b>	Use it to change the transfer/separation output setting when the left deck is used as the source of paper by way of providing a remedial measure. Settings 0: normal (default); 1: separation fault; 2: double transfer; 3: transfer fault	1
<b>TR_SP_C3</b>	Use it to change the transfer/separation output setting when the cassette 3 is used as the source of paper by way of providing a remedial measure. Settings 0: normal (default); 1: separation fault; 2: double transfer; 3: transfer fault	1
<b>TR_SP_C4</b>	Use it to change the transfer/separation output setting when the cassette 4 is used as the source of paper by way of providing a remedial measure. Settings 0: normal (default); 1: separation fault; 2: double transfer; 3: transfer fault	1
<b>TR_SP_MF</b>	Use it to change the transfer/separation output setting when the manual feed tray is used as the source of paper by way of providing a remedial measure. Settings 0: normal (default); 1: separation fault; 2: double transfer; 3: transfer fault	1
<b>TR_SP_DK</b>	Use it to change the transfer/separation output setting when the side paper deck is used as the source of paper by way of providing a remedial measure. Settings 0: normal (default); 1: separation fault; 2: double transfer; 3: transfer fault	1
<b>W/SCNR</b>	Use it to indicate the presence/absence of a reader unit. 0: reader unit absent (printer model) 1: reader unit present (default) When the presence of a reader unit is detected, the machine will automatically set it to '1'.	1
<b>DFDST-L1</b>	Use it to adjust the dust detection level for the ADF (sheet-to-sheet correction). A higher setting will cause the machine to be more sensitive to finer particles of dust. setting: 0 to 225 (Setting the item to '0' will disable the dust detection mechanism.)	1
<b>DFDST-L2</b>	Use it to adjust the dust detection level for the ADF (post-job detection). A higher setting will cause the machine to detect finer particles of dust. setting: 0 to 255 (Setting the item to '0' will disable the dust detection mechanism.)	1
<b>ENVP-INT</b>	Use it to set the interval at which a log is collected for the machine inside temperature/humidity and fixing temperature. COPIER>FUNCTION>MIS-P>ENV-PRT and COPIER>DISPLAY>ENVRNT setting 0 to 480 (default: 60; in min)	1

COPIER > OPTION > BODY		
Sub-item	Description	Level
<b>BASE-SW</b>	Use it to switch from MEAP-full model to base model. setting 0: off (base model) 1: on (full model)	1
<b>SC-L-CNT</b>	Use it to change the threshold level of the paper size (large/small) for the scan counter. setting 0: count B4 as small size (default) 1: count B4 as large size	1
<b>DHON-TM</b>	Use it to set the timing at which drum heater goes on in sleep mode (with reference to clock time). setting: 0 to 24 (default: 0; in hr)	1
<b>DHON-IVL</b>	Use it to set the timing at which the drum heater goes on in sleep mode (with reference to time after a shift to sleep mode). setting: 0, 15 to 1440 (default: 0; in min)	1
<b>DHOF-TM</b>	Use it to set the timing at which the drum heater goes off in sleep mode (with reference to clock time). setting: 0 to 24 (default: 01; in hr)	1
<b>DHOF-IVL</b>	Use it to set the timing at which the drum heater goes off in sleep mode (with reference to time after a shift to sleep mode). setting: 0, 15 to 1440 (default: 0; in min)	1
<b>CBLTINVL</b>	Use it to change the number of times the fixing web solenoid goes on. Make use of it when image faults occur as the result of soiling on the pressure roller. Setting 0: normal (default) 1: twice normal	1
<b>CCD-LUT</b>	Usage setting for the CCD gain correction data Use this item to correct the image deterioration (difference in density at center seam of image) due to aging. Set enabling/disabling data usage corrected with one of the followings: COPIER > FUNCTION > CCD > LUT-ADJ, or LUT-ADJ2. Setting value: 0: not use [default] 1: use (LUT-ADJ correction data) [not available with this machine] 2: use (LUT-ADJ2 correction data)	1
<b>ABC-MODE</b>	Switching the background processing of document (switching digital ABC setting) Setting value: -1: not switch the background density (setting for photo document and document with complex modeling) 0: default 1 to 3: bigger the value is set, lighter the background density is.	1
<b>SJOB-CL</b>	Set whether or not to permit cancellation of the scanning job when a user performs logout. Cancel the operating scanning job when a user performs logout. [Remarks] - "Scanning job" means a job for which scanning operation is completed, and the operation cannot be canceled when the scanning operation is being executed. - Cancellation performed by this mode is saved in the log in the same manner as cancellation performed by a user.  Setting range: 0: Cancellation prohibited 1: Cancellation permitted Factory setting value: 0	1
<b>IFX-CHIG</b>	Set the number of characters to ignore the email message received by IFAX. When the number of characters in the email message received by IFAX is less than the specified number of characters, the message is ignored and is not printed or transferred. When a number other than "0" is specified for the number of characters and the email message disappeared, and also when no TIFF file exists, a blank page with header and footer is printed and transferred. * A kanji character is recognized as a two-byte character. A control code such as CR is also included in the number of characters.  Setting range: 0 to 999 (Unit: number of characters) 0: Do not ignore the email message. Factory setting value: 0	1
<b>BOX-BKUP</b>	For restore control of the BOX backup function.	1

COPIER > OPTION > BODY		
Sub-item	Description	Level
<b>SCANTYPE</b>	<p>Switch the type of reader. This is a service mode used to change the default reader to the optional reader. Use this mode to change the CIS reader to CCD reader.</p> <p>Setting range: 0: default reader 1: Optional reader Factory setting value: 0</p>	1
<b>GR-ADJ-L</b>	<p>Specify the gain setting level for linearity of Red color on the backside. Specify the gain setting level to adjust linearity of the image on the backside against the image on the front side.</p>	1
<b>RAG-CONT</b>	<p>Set the level of fixing smear control mode. 0: No smear 1: Small level of smear 2: Middle level of smear 3: Large level of smear</p>	1
<b>FAXADCHK</b>	<p>Setting the number of times for checking FAX address entry (This is provided for Mizuho Bank.) Specify "N times" for setting the number of times to check FAX address entry. Setting range 0-9 (Default: 2) Perform checking of address entry for multiple times to prevent a mistake in FAX address entry. Actual number of times for checking FAX address entry can be specified. [Factory setting value / Value after execution of RAM clear: 2]</p> <p>Only supports iR5075/5065/5055 Series V2. (BODY No. CHL XXXX, CHM XXXX, CHN XXXX, CHP XXXX, CHQ XXXX, CHU XXXX, CHV XXXX, CHW XXXX, CHZ XXXX, CJA XXXX, CJD XXXX, CJK XXXX, CJP XXXX, CJQ XXXX, CJR XXXX, CJU XXXX, CJZ XXXX, CKA XXXX, CKC XXXX, CKD XXXX, CKE XXXX)</p>	1
<b>OR-ADJ-L</b>	<p>Specify the offset setting level for linearity of Red color on the backside. Specify the offset setting level to adjust linearity of the image on the backside against the image on the front side. Setting value: -5 to 5 (default: 0)</p>	1
<b>ABC-MD2</b>	<p>Adjust the level of base density correction level for reading the backside. Setting value: -1 to 3 (default: 0)</p>	1
<b>MXSPDSEL</b>	<p>To set the skew correction (the idle rotation setting) for different paper width mixed in the original tray. When the skew movement found, perform the idle rotation (additional 2 rotations) in the DF path to increase the paper loop counts of the registration roller; this will correct the skew movement. Setting: 0: w/ idle rotation [default] 1: w/o idle rotation</p>	1
<b>WOLTRANS</b>	<p>Protocol setting for sleep recovery Determine protocols for sleep recovery in accordance with the WOL (Wake On LAN) trans value. 1: wsd&amp;snmp 2: wsd&amp;cpea 3: cpca&amp;snmp [Factory settings and after RAM clear: 1]</p> <p>Reception of specific network packet is one of the conditions that a device recovers from the sleep. As the number of network protocols a device supports has been increased, the type of network packet that triggers sleep recovery has been changed, and a newer network protocol performs the sleep recovery. In an environment where a device is actually used; however, it is possible that the conventional network protocols instead of newer ones are used. Therefore, the type of network packet that triggers sleep recovery should be selectable in accordance with the environment in which the device is used.</p> <p>Only supports iR5075/5065/5055 Series V2. (BODY No. CHL XXXX, CHM XXXX, CHN XXXX, CHP XXXX, CHQ XXXX, CHU XXXX, CHV XXXX, CHW XXXX, CHZ XXXX, CJA XXXX, CJD XXXX, CJK XXXX, CJP XXXX, CJQ XXXX, CJR XXXX, CJU XXXX, CJZ XXXX, CKA XXXX, CKC XXXX, CKD XXXX, CKE XXXX)</p>	1
<b>DWT-SYNC</b>	<p>Scanner printer synchronization control due to the power control at sleep recovery The power has been increased (approximately 40W) due to changing to the 1-path duplexing reader. Therefore, it will be possible that the specified current exceeds with the reservation copy operation when recovering from the sleep. At present, once the scanner starts up, the machine cannot be activated within 30 sec because power of the machine is controlled. In order to startup the machine within 30 sec, set a mode that disables the reservation copy operation (not activating the scanner).</p> <p>Setting range 0: Normal setting 1: Not accept the reservation copy operation during sleep recovery</p> <p>Factory default/default: 0</p> <p>Use this mode when switching the modes: the mode that recovers the machine within 30 sec but not accepts the reservation copy operation, and the mode that accepts the reservation copy operation during sleep recovery.</p> <p>Only supports iR5075/5065/5055 Series V2. (BODY No. CHL XXXX, CHM XXXX, CHN XXXX, CHP XXXX, CHQ XXXX, CHU XXXX, CHV XXXX, CHW XXXX, CHZ XXXX, CJA XXXX, CJD XXXX, CJK XXXX, CJP XXXX, CJQ XXXX, CJR XXXX, CJU XXXX, CJZ XXXX, CKA XXXX, CKC XXXX, CKD XXXX, CKE XXXX)</p>	1

COPIER > OPTION > BODY		
Sub-item	Description	Level
<b>TCPDLACK</b>	<p>Enabled/disabled switch for Delayed Ack function Turning the switch to 0 disables the delayed Ack function of TCP. Setting range 0 to 1 [Value at factory shipping/default: 1]</p> <p>In the case that Delayed Ack causes deteriorated performance of network data transferring in the 10M environment and so on, disable Delayed Ack.</p> <p>Only supports iR5075/5065/5055 Series V2. (BODY No. CHL XXXX, CHM XXXX, CHN XXXX, CHP XXXX, CHQ XXXX, CHU XXXX, CHV XXXX, CHW XXXX, CHZ XXXX, CJA XXXX, CJD XXXX, CJE XXXX, CJK XXXX, CJP XXXX, CJK XXXX, CJR XXXX, CJU XXXX, CJZ XXXX, CKA XXXX, CKC XXXX, CKD XXXX, CKE XXXX)</p>	1
<b>PO-CNTMD</b>	<p>Use it to select the number of times the potential control mechanism goes on. 0: once at power-on 1: once at power-on and, in addition, 10 and 60 min thereafter (simplified potential control mode) 2: once at power-on and, in addition, 10 and 60 min thereafter (normal potential control mode; default)</p>	2
<b>W-CLN-P</b>	<p>Use it to set the interval at which the primary charging wire is automatically cleaned. setting: every 100 to 2000 (sheets; default at 2000)</p>	2
<b>IDL-MODE</b>	<p>Use it to select idle rotation mode for the developing assembly. 0: fix to low humidity mode (off) 1: environment control (default) 2: fix to normal temperature/humidity mode (idle rotation for 120 sec) 3: fix to high humidity mode (idle rotation for 300 sec) 4: power save mode</p>	2
<b>FSPD-S1</b>	<p>Use it to select fixing enhancement mode. 0: normal (default) 1: fixing enhancement mode 2: not used</p>	2
<b>TSPLY-SW</b>	<p>Use it to switch over toner supply sequence. 0: environment control (default) 1: fix to low humidity mode (on for 1.4 sec, off for 1 sec) 2: fix to normal temperature/humidity mode (on for 1.5 sec, off for 1 sec) 3: fix to high humidity mode (on for 3 sec, off for 2 sec)</p>	2
<b>SCANSLCT</b>	<p>Use it to enable/disable the function used to compute the scan area from the selected paper size. setting 0: off (determine scan area by original detection) 1: on (determine scan area by paper size)</p>	2
<b>OHP-TEMP</b>	<p>Use it to switch over control temperature for transparency mode. setting 0: normal (default); 1: -5 deg C; 2: -10 deg C; 3: -15 deg C; 4: -20 deg C</p>	2
<b>SENS-CNF</b>	<p>Use it to set the arrangement of original sensors. setting 0: AB (default) 1: inch</p>	2
<b>RAW-DATA</b>	<p>Use it to specify how received data should be printed. If a received image has a fault, use this mode to find out if the fault is in the data or in image processing. setting 0: normal operation (default) 1: print as is</p>	2
<b>SHARP</b>	<p>Use it to change the level of sharpness (median value). setting: 1 to 5</p>	2
<b>LAPC-SW</b>	<p>Use it to switch over laser APC correction. 0: execute initial rotation APC if left alone for 10 min 1: execute initial rotation APC if left alone for 60 min (default) 2: execute initial rotation if left alone for 120 min 3: disable initial rotation APC only 4: disable</p>	2
<b>FDW-DLV</b>	<p>Use it to select face-up delivery or face-down delivery when the count is set to multiple. setting 0: normal (for a single original, face-up for all; default) 1: for a single original, face-up delivery if the count is set to '1'; otherwise, face-down</p>	2
<b>COTDPC-D</b>	<p>This item is for use at the factory.</p>	2
<b>EVL-VDT</b>	<p>Use it to switch over drum target potential to suit the environment of the site. setting: 0 to 6 (default: 1)</p>	2
<b>RMT-LANG</b>	<p>Use it to change the language for the remote UI to be used through the Web browser. Select the particular language using the + and - keys.</p>	2

COPIER > OPTION > BODY		
Sub-item	Description	Level
<b>HI-HUME</b>	Use it to change the developing bias frequency. If a separation fault occurs in a high humidity environment, set it to '1'. setting 0: 2700 Hz (default); 1: 200 Hz	2
<b>IFAX-LIM</b>	Use it to limit the number of output lines if an excess volume of data is received through i-fax. setting: 0 to 999 (default: 500) 0: no limit	2
<b>DF-BLINE</b>	Use it to execute a remedial measure in response to black lines caused by dust on the platen roller when the ADF is use (stream reading mode). setting 0: disable (default) 1: enable	2
<b>DRM-H-SW</b>	Use it to enable/disable the nighttime drum heater. 0: enable drum heater 1: turn on/off drum heater in keeping with environment (default) 2: disable drum heater	2
<b>SMTPTXPN</b>	Use it to change the SMTP transmission port number. setting: 0 to 65535	2
<b>SMTPRXPN</b>	Use it to change the SMTP reception port number. setting: 0 to 65535	2
<b>POP3PN</b>	Use it to change the POP reception port number. setting: 0 to 65535	2
<b>RUI-DSP</b>	Use it to enable/disable a remote IU function (designed for the Disabilities Act). setting 0: do not show Copier screen on remote UI (default) 1: show Copier screen	2
<b>ORG-LGL</b>	Use it to set a special paper size that the ADF cannot recognize (applicable to LGL communicated by the ADF). setting 0: LGL (default) 1: FOOLSCAP 2: A-FOOLSCAP 3: FOLIO 4: G-LEGAL 5: OFFICIO 6: E-OFFICIO 7: A-OFFICIO 8: B-OFFICIO 9: A-LEGAL 10: M-OFFICIO	2
<b>ORG-LTR</b>	Use it to set a special paper size that the ADF cannot recognize (applicable to LTR communicated by the ADF). setting 0: LTR (default) 1: G-LTR 2: A-LTR 3: EXECUTIVE	2
<b>ORG-LTRR</b>	Use it to set a special paper size that the ADF cannot recognize (applicable to LTR-R communicated by the ADF). setting 0: LTR-R (default) 1: G-LTR-R 2: A-LTR-R 3: EXECUTIVE-R  Only supports iR5075/5065/5055 Series V1.	2
<b>ORG-B5</b>	Select a special paper size that the ADF cannot recognize (applicable to B5 communicated by the ADF). setting 0: B5 (default) 1: K-LEGAL	2
<b>UI-BOX</b>	Use it to enable/disable the display of the box screen on the control panel. setting 0: do not display 1: display (default) 2: do not display (however, permit storage of PDF job in box)	2
<b>UI-SEND</b>	Use it to enable/disable display of the transmission screen on the control panel. setting 0: do not display 1: display (default)	2
<b>UI-FAX</b>	Use it to enable/disable display of the fax screen on the control panel. setting 0: do not display 1: display (default)	2

COPIER > OPTION > BODY		
Sub-item	Description	Level
NW-SPEED	Use it to select the appropriate data transmission speed when a connection is made to a service network. setting 0: auto (default) 1: 100Base-Tx 2: 10Base-T	2
STS-PORT	Use it to enable/disable the port for TOT asynchronous status communications. Use it to enable/disable the port for asynchronous status communications when FTUIF-over-TCP/IP is in use. setting 0: disable (off; default) 1: enable (on)	2
CMD-PORT	Use it to enable/disable the port for TOT synchronous command communications. setting 0: disable (off; default) 1: enable (on)	2
MODELSZ2	Use it to enable/disable platen board original size detection (for global support; AB/inch mix). setting 0: disable global detection (default) 1: enable global detection	2
SZDT-SW	Use it to enable/disable switchover of CCD size detection and photo size detection for platen board original size detection. setting 0: disable photo size detection 1: enable photo size detection	2
NS-CMD5	Use it to limit the use of CRAM-MD5 authentication for SMTP authentication. setting 0: as determined by SMTP server (default) 1: do not use	2
NS-GSAPI	Use it to limit the use of GSSAPI authentication for restrictive SMTP authentication as part of GSSAPI authentication of SMTP authentication. setting 0: as determined by SMTP server (default) 1: do not use	2
NS-NTLM	Use it to limit the use of NTLM authentication for SMTP authentication. setting 0: as determined by SMTP server (default) 1: do not use	2
NS-PLNWS	Use it to limit the use of PLAIN, LOGIN authentication, which is plain-text authentication of SMTP authentication (however, only where PLAIN, LOGIN authentication restrictive communication packets are encrypted). setting 0: as determined by SMTP server (default) 1: do not use	2
NS-PLN	Use it to limit the use of PLAIN, LOGIN authentication, which is plain-text authentication of SMTP authentication (however, only where PLAIN, LOGIN authentication restrictive communication packets are not encrypted). setting 0: as determined by SMTP server (default) 1: do not use	2
NS-LGN	Use it to limit the use of LOGIN authentication for restrictive SMTP authentication of LOGIN authentication. setting 0: as determined by SMTP server (default) 1: do not use	2
MEAP-PN	Use it to change the HTTP port number of a MEAP application. setting: 0 to 65535 (default: 8000)	2
SVMD-ENT	Use it to see how to start service mode: setting 0: User Mode key -> 2 and 8 keys at the same time -> User Mode key (default) 1: User Mode key -> 4 and 9 keys at the same time -> User Mode key	2
SSH-SW	Use it to enable/disable the SSH server function. Setting 0: off (default) 1: on	2
RMT-LGIN	Use it to turning the SSH server function ON or OFF. Setting 0: off (default) 1: on	2
RE-PKEY	Use it to enable/disable regeneration of the SSH server key. setting 0: off (default) 1: on	2
U-NAME	Use it to set user names permitting connection to the SSH server. setting 8 characters max. (alphanumeric)	2

COPIER > OPTION > BODY		
Sub-item	Description	Level
U-PASWD	Use it to set user passwords permitting connection to the SSH server. setting 8 characters max. (alphanumeric)	2
DA-PORT	Use it to enable/disable the port for TOT asynchronous status communication. setting 0: close (default) 1: open (w/ DA installed)	2
DA-CNCT	Use it to set the DA. setting 0: off (default) 1: on	2
CHNG-STG	Use it to set the TOT status connection port number. setting 1 to 65535 (default: 20010)	2
CHNG-CMD	Use it to set the TOT command connection port number. setting 1 to 65535 (default: 20000)	2
MEAP-DSP	Use it to enable/disable a shift from the MEAP to native screen. setting 0: off (shift to native seen; default) 1: on (do not shift to native screen)	2
ANIM-SW	Use it to enable/disable display of the Error/Jam screen with a MEAP application in operation. setting 0: off (display warning screen; default) 1: on (do not display warning screen)	2
MEAP-SSL	Use it to set the HTTPS port for MEAP. setting 0 to 65535 (default: 8443)	2
STNBY-TM	Use it to switch over the standby shift time. setting 0: normal (default) 1: increase standby shift time until possibility of image distortion is absent	2
KSIZE-SW	Use it to enable/disable support of K paper. setting 0: do not support K paper (default) 1: support K paper procedure 1) Set '0' in this service mode. 2) Set '0' for the following: COPIER > OPTION > BODY > MODEL-SZ. 3) Perform the shut-down sequence, and turn off and then on the main power.	2
POST-DWN	A countermeasure mode to prevent smudges from appearing on the lead edge of an image (caused by pre-transfer upper guide) in the HH environment  Decrease the post high pressure output value from 280uA to 70uA only in the HH environment, as an individual countermeasure, in order to prevent smudges from appearing on the lead edge of an image caused by the pre-transfer upper guide. 0: Normal (default) 1: Countermeasure mode (A post high pressure value is automatically changed when an HH environment is detected by the environment sensor.)	2
IMP-MISS	Set OFF/ON for detection of "unmatched" error in the number of printouts. Setting value: 0: OFF [default] 1: ON	2
UI-PRINT	Control the display of a print job screen on the control panel. Use this mode to set whether or not to display a print job screen on the control panel. This mode is available for a user who does not want to display a print job screen on the control panel. Setting range: 0: Do not display the screen. 1: Display the screen.[default]	2
WUEV-SW	Set whether or not to make a sleep notification. Set whether or not to make a sleep notification to the DS application on the network when the copying machine main unit switched its operation to or recovered from sleep operation. Setting range: 0, 1 (0: Make a sleep notification. 1: Do not make a sleep notification.) Factory setting value: 0	2
WUEV-INT	Set the interval for a sleep notification. Set the interval for a sleep notification when "0" is set to WUEV-SW. Setting range: 0 to 65535 (Unit: second) Factory setting value: 600	2
WUEV-POT	Set the port number for the destination of a sleep notification. Set the port number for the destination of a sleep notification when "0" is set to WUEV-SW. Setting range: 0 to 65535 Factory setting value: 11427	2



COPIER > OPTION > BODY		
Sub-item	Description	Level
WUEV-RTR	Set the range of a sleep notification. Set the number of routers used to make a sleep notification when "0" is set to WUEV-SW. Setting range: 1 to 255 Factory setting value: 3	2
SJB-UNW	Switch the number of secure print jobs to be accumulated (scheduled number of jobs). Set "50" or "90" for the upper limit in the number of secure print jobs to be accumulated (scheduled number of jobs). Setting range: 0: 50 1: 90 Factory setting value: 0	2
UI-RSCAN	Control the display of a remote scanning screen on the control panel. Set whether or not to display a remote scanning screen on the control panel. This mode is available for a user who does not want to display the screen on the control panel. Setting range: 0: Do not display the screen. 1: Display the screen. Factory setting value: 1	2
UI-EPRNT	Control the display of an extended printing screen (EFI printing screen) on the control panel. Set whether or not to display an extended printing screen (EFI printing screen) on the control panel. This mode is available for a user who does not want to display the screen on the control panel. [Additional Information] In this screen, the conventional UI-EXT was divided into UI-RSCAN and UI-EPRNT so that each control can be performed separately. Setting range: 0: Do not display the screen. 1: Display the screen. Factory setting value: 1	2
UI-WEB	Control the display of a Web browser screen on the control panel. Set whether or not to display a Web browser screen on the control panel. This mode is available for a user who does not want to display the screen on the control panel. Setting range: 0: Do not display the screen. 1: Display the screen. Factory setting value: 1	2
WEBV-SW	Set whether or not to use the WEBDAV function. When 1 (ON) is set to this mode, the WEBDAV function is unavailable. (WEBDAV related information disappears from the following items. - User mode -> Setting of destination list specifications -> Registration of destinations -> File -> "WEBDAV" in the protocol - User mode -> "Use the chunk split transmission for WEBDAV transmission" in the setting of specifications for transmission [Reference] The WEBDAV function is installed in the main unit as standards, but there are cases when this function is not used in order to reduce the memory usage. Setting range: 0: Use the WEBDAV function. 1: Do not use the WEBDAV function. Factory setting value: 0  When changing into '1', it takes 1 to 2 minutes before the display of WEBDAV is off. After that, return to user mode, check to see that the display of WEBDAV in the above user mode is off and then turn off the power. If turning off the power before the display of WEBDAV is off, the display of WEBDAV is not off by turning on the power again.	2
CARD-RNG	Set the number of available cards. Set the number of available cards used for card reader. Setting range: 1 to 1000 Factory setting value: 1000	2
WUEN-LIV	Set the activation period after a sleep notification is made from the network. Set the period until when the copying machine main unit is placed in the sleep mode next time after activated in the sleep mode from the network without jobs entered. Setting range: 10 to 600 (Unit: second) Factory setting value: 15	2
MAILYEAR	Enter the year/month/date in the subject and file name of an email. (Specifications for Santander Bank in Mexico) Automatically add the year/month/date, time, and allocation number at the end of characters specified for the subject and file name of an email. Setting range: 0: Do not add the year/month/date. 1: Add the year/month/date.	2
SEND-AUT	Switch the setting of user authentication to use SEND function. When setting the switch of this mode to ON (1), a guest button is displayed in the login screen for MEAP, with which user authentication for SEND function is executed. (Only authentication for SEND function can be executed.) If you do not want to use SEND function, press this button so that you can perform login without using an ID and password. [Remarks] When you perform login using the guest button, the setting in this mode does not function. Setting range: 0 (Do not display the guest button.) / 1 (Display the guest button.) Factory setting value: 0	2

COPIER > OPTION > BODY		
Sub-item	Description	Level
<b>DHCP-12</b>	Set whether or not to validate the DHCP-Option 12 request. When the DHCP-12 switch is set to ON, an inquiry about a host name (Option 12) is made by using the DHCP-Option 55. *DHCP (Dynamic Host Configuration Protocol) Setting range: 0: OFF, 1: ON Factory setting value: 1	2
<b>DHCP-81</b>	Set whether or not to validate the DHCP-Option 81 request. When the DHCP-81 switch is set to ON and the dynamic DNS setting is set to ON in the user mode, dynamic change of an IP address by DHCP Option 81 is validated. Setting range: 0: OFF, 1: ON Factory setting value: 1	2
<b>PT3-INEX</b>	Enable switch for paper brand Type 3 import/export To enable the paper brand Type 3 information to be handled by the following functions: - Import/export using remote UI - Distribution of equipment information - Import/export from iWEMC 0: Not enabled 1: Enabled (Default: 0)  Only supports iR5075/5065/5055 Series V2. (BODY No. CHL XXXX, CHM XXXX, CHN XXXX, CHP XXXX, CHQ XXXX, CHU XXXX, CHV XXXX, CHW XXXX, CHZ XXXX, CJA XXXX, CJD XXXX, CJK XXXX, CJP XXXX, CJQ XXXX, CJR XXXX, CJU XXXX, CJZ XXXX, CKA XXXX, CKC XXXX, CKD XXXX, CKE XXXX)	2
<b>USB-RCNT</b>	Set whether or not to perform automatic connection when disconnecting the USB device. (USB RECONNECT) Setting range: 0: Do not perform automatic connection. 1: Perform automatic connection. Factory setting value: 0	2
<b>UI-COPY</b>	Make a setting to switch the display in the copy screen in the control panel. This mode is available for a user who does not want to display a print job screen on the control panel. Setting range: 0: Hide the copy screen. 1: Do not hide the copy screen.[default]	2
<b>MEAP-PRI</b>	Changing the task priority of MEAP The task priority of MEAP increased when this mode is on. 0: OFF 1: ON Default: 1 Use this mode when increasing the MEAP performance.  - Enable to logout even during the process of PDL job. - Display the VxWorks task list from the Console menu, and check the task priority of JVM.  Only supports iR5075/5065/5055 Series V2. (BODY No. CHL XXXX, CHM XXXX, CHN XXXX, CHP XXXX, CHQ XXXX, CHU XXXX, CHV XXXX, CHW XXXX, CHZ XXXX, CJA XXXX, CJD XXXX, CJK XXXX, CJP XXXX, CJQ XXXX, CJR XXXX, CJU XXXX, CJZ XXXX, CKA XXXX, CKC XXXX, CKD XXXX, CKE XXXX)	2
<b>PDLEVCT1</b>	PDL continuous job event decimation To increase the speed of the PDL continuous jobs, install a decimation function for the events to be sent to PDL-PIPIT on the CPCA. The UI display has some mismatch regarding event processing, therefore it shall be allowed for the service technician to turn off the Event Decimation function with Service Switch. This item displays the CPCA event to be decimated and the Status. Setting range 0: No event decimation 1: Decimates job status change/job list change. Status of interaction/executing/complete are excluded. 2: Decimates job status change/job list change. Status of interaction is excluded. [Value of factory shipping/default: 0]  Use when there occurs a complaint of the UI display.  Only supports iR5075/5065/5055 Series V2. (BODY No. CHL XXXX, CHM XXXX, CHN XXXX, CHP XXXX, CHQ XXXX, CHU XXXX, CHV XXXX, CHW XXXX, CHZ XXXX, CJA XXXX, CJD XXXX, CJK XXXX, CJP XXXX, CJQ XXXX, CJR XXXX, CJU XXXX, CJZ XXXX, CKA XXXX, CKC XXXX, CKD XXXX, CKE XXXX)	2
<b>TMP-SHT</b>	Changing the IH shutter switching temperature By increasing the shutter switching temperature for A4R / B5R / LTR-R / LGL (paper width: 170 to 240[mm]), improve the fixability when using thick papers.  Setting values 0: Normal setting (default) 1: Increase the shutter switching temperature by +5 to +10 deg C 2: Increase the shutter switching temperature by +10 to +20 deg C  Improve the fixability for the customers who mainly use A4R / B5R / LTR-R / LGL (paper width: 170 to 240[mm]) thick papers. * It requires extra attention when using thin papers because they may get wrinkled.  Only supports iR5075/5065/5055 Series V2. (BODY No. CHL XXXX, CHM XXXX, CHN XXXX, CHP XXXX, CHQ XXXX, CHU XXXX, CHV XXXX, CHW XXXX, CHZ XXXX, CJA XXXX, CJD XXXX, CJK XXXX, CJP XXXX, CJQ XXXX, CJR XXXX, CJU XXXX, CJZ XXXX, CKA XXXX, CKC XXXX, CKD XXXX, CKE XXXX)	2
<b>PP-LWRT</b>	Not used	2

&lt;USER&gt;

T-17-52

COPIER > OPTION > USER		
Sub-item	Description	Level
<b>COPY-LIM</b>	Use it to put an upper limit to the number of copies. setting: 1 to 9999 (default: 9999)	1
<b>SLEEP</b>	Use it to enable/disable the sleep function. setting 0: off 1: on (default)	1
<b>WEB-DISP</b>	Use it to enable/disable the fixing web length warning message. setting 0: off (do not display) 1: on (display; default) If set to '0', the message will only be on the service mode screen.	1
<b>W-TONER</b>	Use it to enable/disable the collecting toner case full message. setting 0: off (do not display) 1: on (display; default) If set to '0', the message will be only on the service mode screen.	1
<b>COUNTER1</b>	Use it to set soft counter 1 of the user mode screen. 101: total 1 (fixed)	1
<b>COUNTER2</b>	Use it to set soft counter 2 of the user mode screen. setting: 0 to 999	1
<b>COUNTER3</b>	Use it to set soft counter 3 of the user mode screen. setting: 0 to 999	1
<b>COUNTER4</b>	Use it to set soft counter 4 of the user mode screen. setting: 0 to 999	1
<b>COUNTER5</b>	Use it to set soft counter 5 of the user mode screen. setting: 0 to 999	1
<b>COUNTER6</b>	Use it to set soft counter 6 of the user mode screen. setting: 0 to 999	1
<b>CONTROL</b>	Not used	1
<b>B4-L-CNT</b>	Use it to specify where B4 should be counted as large or small size for soft counters 1 through 6. 0: count as small size (default) 1: count as large size	1
<b>COPY-JOB</b>	Use it to enable/disable copy job reservation with a card reader/coin vendor in use. setting 0: enable copy job reservation (default) 1: disable copy job reservation	1
<b>PR-PSESW</b>	Use it to enable/disable the print pause function switch. setting 0: disable print pause function (default) 1: enable print pause function (display print output stop/resume button on user screen)	1
<b>IDPRN-SW</b>	Use it to switch over count increment jobs for the group control counter. 0: for PRINT, increment the following: box print, report print, SEND local print, PDL print (default) 1: for PRINT, increment the following: report print, SEND local print, PDL print	1
<b>CNT-SW</b>	Use it to switch over display of charge counter default items. setting 0: default total 1 (101; default) 1: default total 2 (102), copy total 2 (202), total A total 2 (127) 2: default total 1 (101), total small (104), total large (103), scan total 1 (501)	1
<b>TAB-ACC</b>	Use it to enable/disable automatic switchover of cassettes for tab (index) paper. setting 0: do not change over between tab sheets (default) 1: change over between tab sheets	1
<b>REMPNL</b>	Use it to enable/disable the remote panel function. 0: off (default) 1: on	1
<b>BCNT-AST</b>	Use it to switch over job types for the count of the box prints with ASSIST in use. setting 0: count as PDL job (default) 1: count as copy job	1
<b>DOC-REM</b>	Use it to enable/disable the Remove Original message. setting 0: do not indicate (default) 1: indicate	1

COPIER > OPTION > USER		
Sub-item	Description	Level
<b>FROM-OF</b>	Set whether or not to delete a "from" address for email transmission. Setting value: 0: Do not delete a "from" address. (default) 1: Delete a "from" address.	1
<b>FILE-OF</b>	Set whether or not to prohibit email transmission to the file address. Prohibit transmission to the file address by prohibiting input of the file address from the address book. Setting value: 0: Do not prohibit transmission. (default) 1: Prohibit transmission. If a file address has been already registered, the address can be used even after this mode is set to "1". Therefore, delete the address manually.	1
<b>MAIL-OF</b>	Set whether or not to prohibit transmission to the email address. Prohibit transmission to the email address by prohibiting input of the email address from the address book. Setting value: 0: Do not prohibit transmission. (default) 1: Prohibit transmission. If an email address has been already registered, the address can be used even after this mode is set to "1". Therefore, delete the address manually.	1
<b>IFAX-OF</b>	Set whether or not to prohibit transmission to the IFAX address. Prohibit transmission to the IFAX address by prohibiting input of the IFAX address from the address book. Setting value: 0: Do not prohibit transmission. (default) 1: Prohibit transmission. If an IFAX address has been already registered, the address can be used even after this mode is set to "1". Therefore, delete the address manually.	1
<b>LDAP-DEF</b>	Switch the default value of the LDAP server search condition. Change the default condition for the attribute specified to search detailed information of the LDAP server. Setting value: 0: "Name" (default) 1: "Email" 2: "FAX" 3: "Organization" 4: "Organization unit" 5: User setting 1 6: User setting 2	1
<b>HDCR-DSW</b>	Set whether or not to display the menu of "ON/OFF of complete HDD deletion" in the user mode. User mode > System administration settings > Complete HDD deletion Setting value: 0: Do not display the menu. 1: Display the menu. Factory setting value: 0	1
<b>RVSW-DSP</b>	Display/nondisplay of the switch for 'Reversal Reading' at duplexing print from DADF 0: 'Reversal Reading' switch displayed (default) 1: 'Reversal Reading' switch not displayed  Only supports iR5075/5065/5055 Series V2. (BODY No. CHL XXXX, CHM XXXX, CHN XXXX, CHP XXXX, CHQ XXXX, CHU XXXX, CHV XXXX, CHW XXXX, CHZ XXXX, CJA XXXX, CJD XXXX, CJJ XXXX, CJK XXXX, CJP XXXX, CJK XXXX, CJR XXXX, CJU XXXX, CJZ XXXX, CKA XXXX, CKC XXXX, CKD XXXX, CKE XXXX)	1
<b>SIZE-DET</b>	Use it to enable/disable original size detection. 0: disable original size detection 1: enable original size detection	2
<b>DATE-DSP</b>	Use it to switch over data indication format: setting. 0: 'YY MM/DD 1: DD/MM 'YY 2: MM/DD/YY	2
<b>MB-CCV</b>	Use it to limit the users of the control cards for mail boxes. setting 0: do not limit (default) 1: limit	2
<b>TRY-STP</b>	Use it to switch over operation when the finisher tray becomes full. setting 0: normal (suspend operation when finisher tray becomes full; default) 1: suspend in relation to height detection 2: do not suspend	2
<b>MF-LG-ST</b>	Use it to set the Extra Length key. setting 0: normal (default) 1: indicate Extra Length key on supported mode screens	2
<b>CNT-DISP</b>	Use it to enable/disable indication of a serial number in response to a press on the Counter Check key. setting 0: display serial number (default) 1: do not display serial number	2

COPIER > OPTION > USER		
Sub-item	Description	Level
PH-D-SEL	Select the number of lines for printing in photo mode. 0: 141 lines (default) 1: 134 lines	2
OP-SZ-DT	Use it to enable/disable original size detection for book mode. setting 0: off (require input of size on control panel; default) 1: on (use auto original size detection)	2
NW-SCAN	Use it to permit/not permit the network scan function. setting 0: do to permit network scan function (default) 1: permit network scan function  Caution: For the Japanese model, the value cannot be changed. For a non-Japanese model, PSPCL is fixed to '1'; the value may be changed on other models.	2
HDCR-DSP	Use it to set how HDD full deletion mode may operate. 1: using 0s, delete once (default) 2: using random data, delete once 3: using random data, delete 3 times	2
JOB-INVL	Use it to set the interval of jobs for an interrupt. setting 0: standard (at time of interrupt copy, continuously output next jobs; default) 1: output next job only after delivering last sheet of interrupt copy 2: output next job only after delivering last sheet of all jobs	2
PCL-COPY	Use it to set PCL command COPIES Meru/Pintubo/Hood compatibility. 0: use page-based control according to COPIES command value specified for each page (default) 1: Meru/Pinatubo/Hood compatibility mode 2 to 6535: reserved	2
PRJOB-CP	Use it to set the CCV count pulse generation for reception and report output. setting 0: do not generate count pulse (default) 1: generate count pulse	2
DPT-ID-7	Use it to select the 7-character input method for group ID registration and authentication. setting 0: normal (default) 1: use 7-character input	2
RUI-RJT	Use it to enable/disable connection of the HTTP port at 3 failed attempts at authentication by the RUI. setting 0: make invalid (default) 1: keep valid	2
CTM-S06	Use it to specify whether a password should be removed from the export file (file transmission address). setting 0: do not remove password from export file (default) 1: remove password from export file	2
FREG-SW	Use it to enable/disable display of the free area of the MEAP counter (SEND). setting 0: do not display (default) 1: display	2
IFAX-SZL	Use it to limit transmission size for i-fax transmission. setting 0: keep transmission size limit valid (using server/not using server) 1: keep transmission size limit invalid (only when not using server; default)	2
IFAX-PGD	Use it to enable/disable page-based division transmission (only when the transmission data size upper limit is exceeded). setting 0: do not permit page-based division transmission in i-fax simple mode (default) 1: enable page-based division transmission in i-fax simple mode	2
MEAPSAFE	Use it to enable/disable switchover to safe mode for MEAP. 0: off (default) 1: on (safe mode)	2
AFN-PSWD	Use it to limit access to user mode. setting 0: off (shift to user mode screen without prompting for password; default) 1: on (shift to user mode after password match)	2
PTJAM-RC	Use it to enable/disable PDL jam recovery. setting 0: off (disable recovery) 1: on (enable recovery; default)	2

COPIER > OPTION > USER		
Sub-item	Description	Level
<b>SLP-SLCT</b>	Use it enable/disable use of an existing network-based application. setting 0: do not use (default) 1: use  When set to '1', no shift takes place to sleep mode 3.	2
<b>PS-MODE</b>	Use it to set PS compatibility mode. setting 0: not compatible (default) 1: offer PS type 3 halftone command compatibility (dither reverse) 2: compatible with priority on resolution 3: reserved 4: compatible for EFI landscape/portrait mix 5 to 65535: reserved	2
<b>CNCT-RLZ</b>	Use it to enable/disable the use of the connection serialization function. setting 0: off (disable connection serialization function; default) 1: on (enable connection serialization function)	2
<b>INS-C/S</b>	Expand the inserter function. (Only for a finisher inserter) Setting value: 0: Front cover only (default) 1: Multiple inserters of "front cover + inserted cover" MEMO: - This mode is only available for a finisher inserter. (A perfect binder inserter always supports multiple inserters of "front cover + inserted cover".) - This setting is validated for both copying and printing operation.	2
<b>PDL-NCSW</b>	Set the card management mode for print jobs. Control PDL print jobs using a New Card.  - Conventional operation A PDL print job was received by the machine and printing was performed, regardless of whether or not a New Card was inserted. (Job entry was controlled by the driver on the host side.) - Operation after change When this mode is set to "0", the machine operates in the same manner as the conventional operation. When this mode is set to "1" and when a card is not inserted and the section ID does not match the card ID, printing is not performed. When this mode is set to "1" and when the card ID does not match the section ID of the job after a card is inserted, printing is performed.  Setting range: 0: A PDL print job is received by the machine and printing is performed regardless of whether or not a New Card is inserted. [Factory setting value / Value after RAM clear] 1: When a card is not inserted and the section ID does not match the card ID, printing is not performed. Factory setting value: 0	2
<b>DOM-ADD</b>	Set whether or not to supplement the destination domain for email transmission. Perform transmission with an address in which the address entered for email transmission and the domain specified in the user mode (ex. @xxxx.co.jp) are combined. Setting value: 0: Do not supplement the domain. (default) 1: Supplement the domain. <To send email to "aaaa@xxxx.co.jp"> 1) Specify "xxxx.co.jp" for the domain in the user mode, and specify "1" for this mode. 2) If "aaaa" is entered for email transmission, the address is supplemented as "aaaa@xxx.co.jp".	2
<b>CLR-TIM</b>	Set the timing of complete deletion of processing data. Select the timing to execute complete deletion using the security kit. When complete deletion is executed, performance of job processing may decrease depending on the data. This occurs because processed page data is deleted during job processing and much load is applied to the processing to access the CPU or HDD. When this processing is performed after job processing is completed, job processing capability can be improved. Setting range: 0, 1 (0: Delete data during job processing. 1: Delete data after job processing is completed.) Factory setting value: 0	2
<b>FREE-DSP</b>	Charging/non-charging indication switch When a vendor does not have a hardware switch that changes charging/non-charging indication, a software switch is needed. If such is a case, this mode can be used whether to display the software switch. 0: not display (default) 1: display  Only supports iR5075/5065/5055 Series V2. (BODY No. CHL XXXX, CHM XXXX, CHN XXXX, CHP XXXX, CHQ XXXX, CHU XXXX, CHV XXXX, CHW XXXX, CHZ XXXX, CJA XXXX, CJD XXXX, CJK XXXX, CJP XXXX, CJQ XXXX, CJR XXXX, CJU XXXX, CJZ XXXX, CKA XXXX, CKC XXXX, CKD XXXX, CKE XXXX)	2

COPIER > OPTION > USER		
Sub-item	Description	Level
SNMP-COA	<p>SNMP access restriction switch for internal community name (administrative privilege) Restrict the SNMP access regarding the internally obtained community name (administrative privilege). Setting range 0: OFF 1: ON (Read only) 2: ON (Read/Write available) [default]</p> <p>Usually the SNMP community name can be set using the following item; [Additional Functions]&gt;[System Settings]&gt;[Network Settings]&gt;[SNMP Settings]. There is an internal community name (administrative privilege) in addition to the community name that is set in the above item, and it is used at the time of access using the Canon utility software such as NetSpot. In the case that the SNMP access using an internal community name needs to be restricted in view of security, set this item to '0' or '1'.</p> <p>Only supports iR5075/5065/5055 Series V2. (BODY No. CHL XXXX, CHM XXXX, CHN XXXX, CHP XXXX, CHQ XXXX, CHU XXXX, CHV XXXX, CHW XXXX, CHZ XXXX, CJA XXXX, CJD XXXX, CJI XXXX, CJK XXXX, CJP XXXX, CJQ XXXX, CJR XXXX, CJU XXXX, CJZ XXXX, CKA XXXX, CKC XXXX, CKD XXXX, CKE XXXX)</p>	2
SNMP-COU	<p>SNMP access restriction switch for internal community name (user privilege) Restrict the SNMP access regarding the internally obtained community name (user privilege). Setting range 0: OFF 1: ON (Read only) 2: ON (Read/Write available) [default]</p> <p>Usually the SNMP community name can be set using the following item; [Additional Functions]&gt;[System Settings]&gt;[Network Settings]&gt;[SNMP Settings]. There is an internal community name (user privilege) in addition to the community name that is set in the above item, and it is used at the time of access using the Canon utility software such as NetSpot. In the case that the SNMP access using an internal community name needs to be restricted in view of security, set this item to '0' or '1'.</p> <p>Only supports iR5075/5065/5055 Series V2. (BODY No. CHL XXXX, CHM XXXX, CHN XXXX, CHP XXXX, CHQ XXXX, CHU XXXX, CHV XXXX, CHW XXXX, CHZ XXXX, CJA XXXX, CJD XXXX, CJI XXXX, CJK XXXX, CJP XXXX, CJQ XXXX, CJR XXXX, CJU XXXX, CJZ XXXX, CKA XXXX, CKC XXXX, CKD XXXX, CKE XXXX)</p>	2

## Soft Counter Specifications

100s: total

200s: copy (as needed, add 001 and up)

300s: print

400s: copy + print

500s: scan

600s: box print

700s: reception print

800s: report print

900s: transmission

&lt;Guide to Symbols&gt;

Yes: counter used in the machine.

large size: paper larger than B4.

small size: paper that is B4 or smaller.

numbers 1 and 2 under Description indicate the count for large size paper.

(The machine may be set so that it will count B4 and larger paper as a large size paper in service mode: COPIER&gt;OPTION&gt;USER&gt;B4-L-CNT).

total A: total excluding local copy + remote copy.

total B: total excluding local copy + remote copy + box print.

copy: local copy + remote copy.

copy A: local copy + remote copy + box print.

print: PDL print + report print + box print.

print A: PDL print + report print.

scan: black-and-white scan + color scan

T-17-53

COPIER > COUNTER		
No.	Description	Level
101	total 1	Yes
102	total 2	Yes
103	total (large)	Yes
104	total (small)	Yes
105	total (full color 1)	
106	total (full color 2)	
108	total (black-and-white 1)	Yes
109	total (black-and-white 2)	Yes
110	total (mono color; large)	
111	total (mono color; small)	
112	total (back-and-white; large)	Yes
113	total (black-and-white; small)	Yes
114	total 1 (duplex)	Yes
115	total 2 (duplex)	Yes
116	large (duplex)	Yes
117	small (duplex)	Yes
118	total (mono color 1)	
119	total (mono color 2)	
120	total (full color; large)	
121	total (full color; small)	

COPIER > COUNTER		
No.	Description	Level
122	total (full color + mono color; large)	
123	total (full color + mono color; small)	
124	total (full color + mono color 2)	
125	total (full color + mono color 1)	
126	total A1	Yes
127	total A2	Yes
128	total A (large)	Yes
129	total A (small)	Yes
130	total A (full color 1)	
131	total A (full color 2)	
132	total A (black-and-white 1)	Yes
133	total A (black-and-white 2)	Yes
134	total A (mono color; large)	
135	total A (mono color; small)	
136	total A (black-and-white; large)	Yes
137	total A black-and-white; small)	Yes
138	total A1 (duplex)	
139	total A2 (duplex)	
140	large A (duplex)	
141	small A (duplex)	
142	total A (mono color 1)	
143	total A (mono color 2)	
144	total A (full color; large)	
145	total A (full color; small)	
146	total A (full color + mono color; large)	
147	total A (full color + mono color; small)	
148	total A (full color + mono color 2)	
149	total A (full color + mono color 1)	
150	total B1	Yes
151	total B2	Yes
152	total B (large)	Yes
153	total B (small)	Yes
154	total B (full color 1)	
155	total B (full color 2)	
156	total B (black-and-white 1)	Yes
157	total B (black-and-white 2)	Yes
158	total B (mono color; large)	
159	total B (mono color ; small)	
160	total B (black-and-white; large)	Yes
161	total B (black-and-white; small)	Yes
162	total B1 (duplex)	
163	total B2 (duplex)	
164	large B (duplex)	
165	small B (duplex)	
166	total B (mono color 1)	
167	total B (mono color 2)	
168	total B (full color; large)	
169	total B (full color; small)	
170	total B (full color + mono color; large)	
171	total B (full color + mono color; small)	
172	total B (full color + mono color 2)	
173	total B (full color + mono color 1)	
201	copy (total 1)	Yes
202	copy (total 2)	Yes
203	copy (large)	Yes
204	copy (small)	Yes
205	copy A (total 1)	Yes
206	copy A (total 2)	Yes
207	copy A (large)	Yes
208	copy A (small)	Yes
209	local copy (total 1)	Yes
210	local copy (total 2)	Yes
211	local copy (large)	Yes
212	local copy (small)	Yes
213	remote copy (total 1)	Yes



COPIER > COUNTER		
No.	Description	Level
214	remote copy (total 2)	Yes
215	remote copy (large)	Yes
216	remote copy (small)	Yes
217	copy (full color 1)	
218	copy (full color 2)	
219	copy (mono color 1)	
220	copy (mono color 2)	
221	copy (black-and-white 1)	Yes
222	copy (black-and-white 2)	Yes
223	copy (full color; large)	
224	copy (full color; small)	
225	copy (mono color; large)	
226	copy (mono color; small)	
227	copy (black-and-white; large)	Yes
228	copy (black-and-white; small)	Yes
229	copy (full color + mono color; large)	
230	copy (full color + mono color; small)	
231	copy (full color + mono color/2)	
232	copy (full color + mono color/1)	
233	copy (full color; large; duplex)	
234	copy (full color; small; duplex)	
235	copy (mono color; large; duplex)	
236	copy (mono color; small; duplex)	
237	copy (black-and-white; large; duplex)	
238	copy (black-and-white; small; duplex)	
245	copy A (full color 1)	
246	copy A (full color 2)	
247	copy A (mono color 1)	
248	copy A (mono color 2)	
249	copy A (black-and-white 1)	Yes
250	copy A (black-and-white 2)	Yes
251	copy A (full color; large)	
252	copy A (full color; small)	
253	copy A (mono color; large)	
254	copy A (mono color; small)	
255	copy A (black-and-white; large)	Yes
256	copy A (black-and-white; small)	Yes
257	copy A (full color + mono color; large)	
258	copy A (full color + mono color; small)	
259	copy A (full color + mono color 2)	
260	copy A (full color + mono color 1)	
261	copy A (full color; large; duplex)	
262	copy A (full color; small; duplex)	
263	copy A (mono color; large; duplex)	
264	copy A (mono color; small; duplex)	
265	copy A (black-and-white; large; duplex)	
266	copy A (black-and-white; small; duplex)	
273	local copy (full color 1)	
274	local copy (full color 2)	
275	local copy (mono color 1)	
276	local copy (mono color 2)	
277	local copy (black-and-white 1)	Yes
278	local copy (black-and-white 2)	Yes
279	local copy (full color; large)	
280	local copy (full color; small)	
281	local copy (mono color; large)	
282	local copy (mono color; small)	
283	local copy (black-and-white; large)	Yes
284	local copy (black-and-white; small)	Yes
285	local copy (full color + mono color; large)	
286	local copy (full color + mono color; small)	
287	local copy (full color + mono color 2)	
288	local copy (full color + mono color 1)	
289	local copy (full color; large; duplex)	
290	local copy (full color; small; duplex)	

COPIER > COUNTER		
No.	Description	Level
291	local copy (mono color; large; duplex)	
292	local copy (mono color; small; duplex)	
293	local copy (black-and-white; large; duplex)	
294	local copy (black-and-white; small; duplex)	
002	remote copy (full color 1)	
003	remote copy (full color 2)	
004	remote copy (mono color 1)	
005	remote copy (mono color 2)	
006	remote copy (black-and-white 1)	Yes
007	remote copy (black-and-white 2)	Yes
008	remote copy (full color; large)	
009	remote copy (full color; small)	
010	remote copy (mono color; large)	
011	remote copy (mono color; small)	
012	remote copy (black-and-white; large)	Yes
013	remote copy (black-and-white; small)	Yes
014	remote copy (full color + mono color; large)	
015	remote copy (full color + mono color; small)	
016	remote copy (full color + mono color 2)	
017	remote copy (full color + mono color 1)	
018	remote copy (full color; large; duplex)	
019	remote copy (full color; small; duplex)	
020	remote copy (mono color; large; duplex)	
021	remote copy (mono color; small; duplex)	
022	remote copy (black-and-white; large; duplex)	
023	remote copy (black-and-white; small; duplex)	
301	print (total 1)	Yes
302	print (total 2)	Yes
303	print (large)	Yes
304	print (small)	Yes
305	print A (total 1)	Yes
306	print A (total 2)	Yes
307	print A (large)	Yes
308	print A (small)	Yes
309	print (full color 1)	
310	print (full color 2)	
311	print (mono color 1)	
312	print (mono color 2)	
313	print (black-and-white 1)	Yes
314	print (black-and-white 2)	Yes
315	print (full color; large)	
316	print (full color; small)	
317	print (mono color; large)	
318	print (mono color; small)	
319	print (black-and-white; large)	Yes
320	print (black-and-white; small)	Yes
321	print (full color + mono color; large)	
322	print (full color + mono color; small)	
323	print (full color + mono color/2)	
324	print (full color + mono color/1)	
325	print (full color; large; duplex)	
326	print (full color; small; duplex)	
327	print (mono color; large; duplex)	
328	print (mono color; small; duplex)	
329	print (black-and-white; large; duplex)	
330	print (black-and-white; small; duplex)	
331	PDL print (total 1)	Yes
332	PDL print (total 2)	Yes
333	PDL print (large)	Yes
334	PDL print (small)	Yes
335	PDL print (full color 1)	
336	PDL print (full color 2)	
339	PDL print (black-and-white 1)	Yes
340	PDL print (black-and-white 2)	Yes
341	PDL print (full color; large)	

COPIER > COUNTER		
No.	Description	Level
342	PDL print (full color; small)	
345	PDL print (black-and-white; large)	Yes
346	PDL print (black-and-white;small)	Yes
351	PDL print (full color; large; duplex)	
352	PDL print (full color; small; duplex)	
355	PDL print (black-and-white; large; duplex)	
356	PDL print (black-and-white; small; duplex)	
401	copy + print (full color; large)	
402	copy + print (full color; small)	
403	copy + print (black-and-white; large)	
404	copy + print (black-and-white; small)	
405	copy + print (black-and-white 2)	
406	copy + print (black-and-white 1)	
407	copy + print (full color + mono color; large)	
408	copy + print (full color + mono color; small)	
409	copy + print (full color + mono color/2)	
410	copy + print (full color + mono color/1)	
411	copy + print (large)	
412	copy + print (small)	
413	copy + print (2)	
414	copy + print (1)	
415	copy + print (mono color; large)	
416	copy + print (mono color; small)	
417	copy + print (full color; large; duplex)	
418	copy + print (full color; small; duplex)	
419	copy + print (mono color; large; duplex)	
420	copy + print (mono color; small; duplex)	
421	copy + print (black-and-white; large; duplex)	
422	copy + print (black-and-white; small; duplex)	
501	scan (total 1)	Yes
502	scan (total 2)	Yes
503	scan (large)	Yes
504	scan (small)	Yes
505	black-and-white scan (total 1)	Yes
506	black-and-white scan (total 1)	Yes
507	black-and-white scan (total 2)	Yes
508	black-and-white scan (large)	Yes
509	black-and-white scan (small)	
510	color scan (total 1)	
511	color scan (total 2)	
512	color scan (large)	
601	color scan (small)	Yes
602	box print (total 1)	Yes
603	box print (total 2)	Yes
604	box print (large)	Yes
605	box print (small)	
606	box print (full color 1)	
607	box print (full color 2)	
608	box print (mono color 1)	
609	box print (black-and-white 1)	Yes
610	box print (black-and-white 2)	Yes
611	box print (full color; large)	
612	box print (full color; small)	
613	box print (mono color; large)	
614	box print (mono color; small)	
615	box print (black-and-white; large)	Yes
616	box print (black-and-white; small)	Yes
617	box print (full color + mono color; large)	
618	box print (full color + mono color; small)	
619	box print (full color + mono color 2)	
620	box print (full color + mono color 1)	
621	box print (full color; large; duplex)	
622	box print (full color; small; duplex)	
623	box print (mono color; large; duplex)	
624	box print (mono color; small; duplex)	

COPIER > COUNTER		
No.	Description	Level
625	box print (black-and-white; large; duplex)	
626	box print (black-and-white; small; duplex)	
701	reception print (total 1)	Yes
702	reception print (total 2)	Yes
703	reception print (large)	Yes
704	reception print (small)	Yes
705	reception print (full color 1)	
706	reception print (full color 2)	
707	reception print (grayscale 1)	
708	reception print (grayscale 2)	
709	reception print (black-and-white 1)	Yes
710	reception print (black-and-white 2)	Yes
711	reception print (full color; large)	
712	reception print (full color; small)	
713	reception print (grayscale; large)	
714	reception print (grayscale; small)	
715	reception print (black-and-white; large)	Yes
716	reception print (black-and-white; small)	Yes
717	reception print (full color + grayscale; large)	
718	reception print (full color + grayscale; small)	
719	reception print (full color + grayscale 2)	
720	reception print (full color + grayscale 1)	
721	reception print (full color; large; duplex)	
722	reception print (full color; small; duplex)	
723	reception print (grayscale; large; duplex)	
724	reception print (grayscale; small; duplex)	
725	reception print (black-and-white; large; duplex)	
726	reception print (black-and-white; small; duplex)	
801	report print (total 1)	Yes
802	report print (total 2)	Yes
803	report print (large)	Yes
804	report print (small)	Yes
805	report print (full color 1)	
806	report print (full color 2)	
807	report print (grayscale 1)	
808	report print (grayscale 2)	
809	report print (black-and-white 1)	Yes
810	report print (black-and-white 2)	Yes
811	report print (full color; large)	
812	report print (full color; small)	
813	report print (grayscale; large)	
814	report print (grayscale; small)	
815	report print (black-and-white; large)	Yes
816	report print (full color + grayscale; large)	Yes
817	report print (full color + grayscale; small)	
818	report print (full color + grayscale; small)	
819	report print (full color + grayscale 2)	
820	report print (full color; large; duplex)	
821	report print (full color; large; duplex)	
822	report print (full color; small; duplex)	
823	report print (grayscale; large; duplex)	
824	report print (grayscale; small; duplex)	
825	report print (black-and-white; large; duplex)	
826	report print (black-and-white; small; duplex)	
901	copy scan total 1 (color)	
902	copy scan total 1 (black-and-white)	
903	copy scan total 2 (color)	
904	copy scan total 2 (black-and-white)	
905	copy scan total 3 (color)	
906	copy scan total 3 (black-and-white)	
907	copy scan total 4 (color)	
908	copy scan total 4 (black-and-white)	
909	local copy scan (color)	
910	local copy scan (black-and-white)	

COPIER > COUNTER		
No.	Description	Level
911	remote copy scan (color)	
912	remote copy scan (black-and-white)	
913	transmission scan total 1 (color)	
914	transmission scan total 1 (black-and-white)	
915	transmission scan total 2 (color)	
916	transmission scan total 2 (black-and-white)	Yes
917	transmission scan total 3 (color)	
918	transmission scan total 3 (black-and-white)	Yes
919	transmission scan total 4 (color)	
920	transmission scan total 4 (black-and-white)	
921	transmission scan total 5 (color)	
922	transmission scan total 5 (black-and-white)	Yes
929	transmissions scan total 6 (color)	
930	transmission scan total; 6 (black-and-white)	Yes
931	transmission scan total 7 (color)	
932	transmission scan total 7 (black-and-white)	
933	transmission scan total 8 (color)	
934	transmission scan total 8 (black-and-white)	
935	universal transmission scan total (color)	
936	universal transmission scan total (black-and-white)	
937	box scan (color)	
938	box scan (black-and-white)	
939	remote scan (color)	
940	remote scan (black-and-white)	Yes
941	transmission scan/fax (color)	
942	transmission scan/fax (black-and-white)	
943	transmission scan/i-fax (color)	
944	transmission scan/i-fax (black-and-white)	
945	transmission scan/e-mail (color)	
946	transmission scan/e-mail (black-and-white)	
947	transmission scan/FTP (color)	
948	transmission scan/FTP (black-and-white)	
949	transmission scan/SMB (color)	
950	transmission scan/SMB (black-and-white)	
951	transmission scan/IPX (color)	
952	transmission scan/IPX (black-and-white)	
953	transmission scan/database (black-and-white)	
954	transmission scan/database (color)	
955	transmission scan/local print (color)	
956	transmission scan/local print (black-and-white)	
957	transmission scan/box (color)	
958	transmission scan/box (black-and-white)	

&lt;CST&gt;

T-17-54

COPIER > OPTION > CST		
Sub-item	Description	Level
<b>P-SZ-C1</b>	Use it to set the paper size (right deck). setting: 6: A4 (default); 15: B5; 18: LTR	1
<b>P-SZ-C2</b>	Use it to set the paper size (left deck). setting: 6: A4 (default); 15: B5; 18: LTR	1
<b>U1-NAMEto U4-NAME</b>	Use it to enable/disable display of a paper name when a size from a specific paper size group (U1 to U4) is detected. setting 0: on the touch panel, indicate U1, U2, U3, U4 (default) 1: indicate paper name selected in service mode: CST-U1, U2, U3, U4	2

COPIER > OPTION > CST		
Sub-item	Description	Level
<b>CST-U1/U2/U3/U4</b>	Use it to select paper names used in paper size groups. By setting any of the following special paper sizes for U1, U2, U3, and U4, these paper sizes may be recognized as special size papers for the universal cassette in question. setting 24: Foolscap (CST-U2; default) 25: Australian Foolscap 26: Oficio 27: Ecuadorian Oficio 28: Bolivian Oficio 29: Argentine Letter (U4; default) 30: Argentine Letter-R 31: Government Letter (U1; default) 32: Government Letter (U1; default) 32: Government Letter-R 34: Government Legal (U3; default) 35: Folio 36: Argentine Oficio 37: Mexico Oficio 38: Executive	2

&lt;ACC&gt;

T-17-55

COPIER > OPTION > ACC		
Sub-item	Description	Level
<b>COIN</b>	Coin vendor switching This selects whether to establish the coin vendor control mode. Settings 0: Coin vendor not used (control cards can be used; not charged) 1: Coin vendor (charged) 2: Remote area counter (charged) 3: Charged by DA 4: Charged by iR [Factory setting/value after clearing RAM: 0] Note: When the setting has been changed to "3" (DA charges), the values of the following items will also be changed. [Service mode] - COPIER>OPTION>USER>CONTROL:1 - COPIER>OPTION>USER>AFN-PSWD:1 - COPIER>OPTION>BODY>UI-BOX:0 - COPIER>OPTION>BODY>UI-SEND:0 - COPIER>OPTION>BODY>UI-FAX:0 - COPIER>OPTION>BODY>UI-EXT:0 - COPIER>OPTION>BODY>DA-CNCT:1 [User mode > system control settings] - Expansion unit settings > expansion unit function priority: ON - Network settings > email > I fax > SMTP reception: OFF - Network settings > email > I fax > POP3 reception: OFF - Network settings > SMB settings > use of SMB printing: 0 - Network settings > TCP/IP settings > use of IPP printing: 0 - Network settings > TCP/IP settings > IP address range setting > printing enable address ON/OFF: ON Network settings > TCP/IP settings > use of FTP printing: OFF  Only supports iR5075/5065/5055 Series V2. (BODY No. CHL XXXX, CHM XXXX, CHN XXXX, CHP XXXX, CHQ XXXX, CHU XXXX, CHV XXXX, CHW XXXX, CHZ XXXX, CJA XXXX, CJD XXXX, CJE XXXX, CJK XXXX, CJP XXXX, CJK XXXX, CJR XXXX, CJU XXXX, CJZ XXXX, CKA XXXX, CKC XXXX, CKD XXXX, CKE XXXX)	1
<b>DK-P</b>	Use it to set the size of paper used in the Side Paper Deck.(for the Side Paper Deck AD1) setting 0: A4 (default) 1: B5 2: LTR	1
<b>CCV2CT</b>	Use it to enable/disable large 2 count control. 0: off (disable 2-count control; default) 1: on (enable 2-count control; count pulse width/pulse width, 100 msec) 2: on (enable 2-count control; count pulse width/pulse width, 30 msec)	1
<b>CCV-LSZ</b>	Use it to set a threshold for small/large size identification used in large 2 count mode. setting: 0 to 458 (default: 364; in mm)	1
<b>PD-SIZE</b>	Setting size of the Side Paper Deck AE1 (displayed only the Side Paper Deck AE1 is mounted) Normal size can be set with the user mode, and special size can be set with the service mode. Setting Range: 0 to 37 [default: 0] The value 0 or 22 to 37 can be set with the service mode. If the setting value is 0 to 21, the value 1 to 21 can be input with the user mode.	1

COPIER > OPTION > ACC		
Sub-item	Description	Level
MIN-PRC	<p>Coin manager minimum value setting This determines the minimum value handled by the coin manager which is connected. For instance, the service technician inputs "10" if the minimum value supported by the Japanese yen coin manager is 10 yen. This item takes effect only when 4 is set for ACC&gt;COIN. Additional note When a number from 1 to 4 (Euros, pounds, Swiss francs, dollars) is set for COPIER&gt;OPTION&gt;ACC&gt;UNIT-PRC, a fractional monetary unit can be input. For instance, an input of "50" signifies 50 cents (\$0.50). Setting range: 0 to 9999 [Factory setting/value after clearing RAM: 10]</p> <p>Only supports iR5075/5065/5055 Series V2. (BODY No. CHL XXXX, CHM XXXX, CHN XXXX, CHP XXXX, CHQ XXXX, CHU XXXX, CHV XXXX, CHW XXXX, CHZ XXXX, CJA XXXX, CJD XXXX, CJJ XXXX, CJK XXXX, CJP XXXX, CJQ XXXX, CJR XXXX, CJU XXXX, CJZ XXXX, CKA XXXX, CKC XXXX, CKD XXXX, CKE XXXX)</p>	1
MAX-PRC	<p>Coin manager maximum value setting This determines the maximum value handled by the coin manager which is connected. An error screen is displayed if a value lower than the smallest unit is input when inputting the charge amount using initial settings/registration. For instance, the service technician inputs "8900" if the maximum value supported by the Japanese yen coin manager is 8900 yen. This item takes effect only when 4 is set for ACC&gt;COIN. Additional note When a number from 1 to 4 (Euros, pounds, Swiss francs, dollars) is set for COPIER&gt;OPTION&gt;ACC&gt;UNIT-PRC, a fractional monetary unit can be input. For instance, an input of "50" signifies 50 cents (\$0.50). Setting range: 0 to 9999 [Factory setting/value after clearing RAM: 0]</p> <p>Only supports iR5075/5065/5055 Series V2. (BODY No. CHL XXXX, CHM XXXX, CHN XXXX, CHP XXXX, CHQ XXXX, CHU XXXX, CHV XXXX, CHW XXXX, CHZ XXXX, CJA XXXX, CJD XXXX, CJJ XXXX, CJK XXXX, CJP XXXX, CJQ XXXX, CJR XXXX, CJU XXXX, CJZ XXXX, CKA XXXX, CKC XXXX, CKD XXXX, CKE XXXX)</p>	1
CC-SPSW	<p>Use it to set control card I/F support. 0: do not support (default) 1: support</p>	2
UNIT-PRC	<p>Unit price setting for coin vendors Sets unit price for coin vendors. Setting values 0: Yen 1: Euro 2: Pound 3: Swiss Franc 4: Dollar 5: No unit, no fractional unit. 6: No unit, with fractional unit. [Factory settings and after RAM clear: 0]</p> <p>Only supports iR5075/5065/5055 Series V2. (BODY No. CHL XXXX, CHM XXXX, CHN XXXX, CHP XXXX, CHQ XXXX, CHU XXXX, CHV XXXX, CHW XXXX, CHZ XXXX, CJA XXXX, CJD XXXX, CJJ XXXX, CJK XXXX, CJP XXXX, CJQ XXXX, CJR XXXX, CJU XXXX, CJZ XXXX, CKA XXXX, CKC XXXX, CKD XXXX, CKE XXXX)</p>	2

&lt;INT-FACE&gt;

T-17-56

COPIER > OPTION > INT-FACE		
Sub-item	Description	Level
IMG-CONT	<p>Use it to set the connection of the EFI controller. setting 0: no controller 1: EFI model (PINATUBO, Mt. Hood) 2: T/R, AHT model 3: EFI external controller present (Yukon/Pinatubo V2.0) 4: EFI external controller present (Meru V3.1)</p>	1
AP-OPT	<p>Use it to permit/not permit printing from application PrintMe built into the PS print server unit. setting 0: permit printing using unspecific ID (default) 1: permit printing using specific account 2: reject printing</p>	2
AP-ACCNT	<p>Use it to set (CPCA) group ID for printing (job) from application PrintMe built into the PS print server unit. setting 0 to 9999999 (default: 0)</p>	2
AP-CODE	<p>Use it to set the (CPCA) path for printing (job) from application PrintMe built into the PS print server unit. setting 0 to 99999999 (default: 0)</p>	2

&lt;TEMPO&gt;

COPIER > OPTION > TEMPO		
Sub-item	Description	Level
F-POT-SW	Use it to enable/disable settings in the event of a transfer fault caused by a fault in the potential sensor. - Use it as a tentative remedy until the potential sensor is replaced. settling 0: off (default); 1: on	2
F-POT-D	Use it to make settings in relation to transfer faults caused by a fault in the potential sensor. - The setting will be valid only when F-POT-SW is set to '1'. - The degree of separation current may be 0>1>2. setting 0: if user tends to use originals with low image ratio (text original) 1: if user tends to use originals with high image ratio (photo original) 2: do not use normally; however, use if double transfer occurs (dropout at about 50 mm of leading edge)	2
F-HUM-SW	Use it to enable/disable F-HUM-D settings in the event of a fault in the environment sensor. - Use it as a tentative remedy until the environment sensor is replaced. setting 0: off (default); 1: on (enable F-HUM-D setting)	2
F-HUM-D	Use it to manually set the humidity for the site of installation. - The machine assumes it as the output of the humidity sensor. - The setting will be valid only when F-HUM-SW is '1'. setting: 30 to 99 (default: 35%)	2

## &lt;LCNS-TR&gt;

COPIER > OPTION > LCNS-TR		
Sub-item	Description	Level
EX: ST-XXXX 1 ( ) {0 to 0} [1] [2] [1]: for state indication, 0: not installed (default); 1: installed [2]: for invalidation execution, 0: execute (input accepted only if '0') Procedure (invalidation of transfer) 1) Select SET-XXXX, and type in '0'; then, press the OK key. 2) See that a transfer license number (24 characters) is indicated for TR-XXXX.		
ST-SEND	Use it to display the installation state/invalidate transfer of the SEND function as part of transfer invalidation.	2
TR-SEND	Use it to obtain a transfer license key for the SEND function as part of transfer invalidation.	2
ST-ENPDF	Use it to display the installation state/to execute transfer invalidation of the SEND encryption PDF transmission function as part of transfer invalidation.	2
TR-ENPDF	Use it to obtain a transfer license key for the SEND encryption PDF transmission function as part of transfer invalidation.	2
ST-SPDF	Use it to display the installation state/to execute transfer invalidation of the SEND searchable PDF transmission function as part of transfer invalidation.	2
TR-SPDF	Use it to obtain a transfer license key for the SEND searchable PDF transmission function as part of transfer invalidation.	2
ST-EXPDF	Use it to display the installation state/to execute transfer invalidation of the PDF expansion (composite function of encryption PDF + searchable PDF) as part of transfer invalidation.	2
TR-EXPDF	Use it to obtain a transfer license key for the PDF expansion kit (composite function of encryption PDF + searchable PDF) as part of transfer invalidation.	2
ST-PDFDR	Use it to display the installation state/to execute transfer invalidation of the PDF direct transmission mechanism as part of transfer invalidation.	2
TR-PDFDR	Use it to obtain a transfer license key as part of transfer invalidation.	2
ST-SCR	Use it to display the installation sate/execute transfer invalidation of the encryption secured printing function as part of transfer invalidation.	2
TR-SCR	Use it to obtain a transfer license key for the encryption secured printing as part of transfer invalidation.	2
ST-CHSNG	Not used	2
TR-CHSNG	Not used	2
ST-BRDIM	Use it to display/execute transfer invalidation of Bar DIMM as part of transfer invalidation.	2
TR-BRDIM	Use it to obtain a transfer license key for bar DIMM as part of transfer invalidation.	2
ST-VNC	Use it to display the installation state/to execute transfer invalidation for VNC as part of transfer invalidation.	2
TR-VNC	Use it to obtain a transfer license key for VNC as part of transfer invalidation.	2



COPIER > OPTION > LCNS-TR		
Sub-item	Description	Level
ST-WEB	Use it to display the installation state/execute transfer invalidation for a WEB browser as part of transfer invalidation.	2
TR-WEB	Use it to obtain a transfer license key for a WEB browser as part of transfer invalidation.	2
ST-WTMRK	Display the installation status of the tint block printing function in transfer invalidation. / Execute transfer invalidation.	2
TR-WTMRK	Obtain a transfer license key for the tint block printing function in transfer invalidation.	2
ST-TSPDF	Display the installation status of the PDF send function with a time stamp in transfer invalidation.	2
TR-TSPDF	Obtain a transfer license key for the PDF send function with a time stamp in transfer invalidation.	2
ST-USPDF	Display the installation status of the PDF send function with a user signature in transfer invalidation.	2
TR-USPDF	Obtain a transfer license key for the PDF send function with a user signature in transfer invalidation.	2
ST-DVPDF	Display the installation status of the PDF send function with a device signature in transfer invalidation.	2
TR-DVPDF	Obtain a transfer license key for the PDF send function with a device signature in transfer invalidation.	2
ST-SCPDF	Display the installation status of the scalable PDF send function in transfer invalidation.	2
TR-SCPDF	Obtain a transfer license key for the scalable PDF send function in transfer invalidation.	2
ST-AMS	Display the installation status of ACQ in transfer invalidation.	2
TR-AMS	Obtain a transfer license key for ACQ in transfer invalidation.	2
ST-ERDS	Display the installation status of the ERDS 3rd party advanced function in transfer invalidation.	2
TR-ERDS	Obtain a transfer license key for the ERDS 3rd party advanced function in transfer invalidation.	2
ST-PS	Display the installation status of PS in transfer invalidation.	2
TR-PS	Obtain a transfer license key for PS in transfer invalidation.	2
ST-PCL	Display the installation status of PCL in transfer invalidation.	2
TR-PCL	Obtain a transfer license key for PCL in transfer invalidation.	2
ST-PSLI5	Display the installation status of PS, LIPS4, and LIPS LX in transfer invalidation.	2
TR-PSLI5	Obtain a transfer license key for PS, LIPS4, and LIPS LX in transfer invalidation.	2
ST-LIPS5	Display the installation status of LIPS LX and LIPS4 in transfer invalidation.	2
TR-LIPS5	Obtain a transfer license key for LIPS LX and LIPS4 in transfer invalidation.	2
ST-LIPS4	Display the installation status of LIPS4 in transfer invalidation.	2
TR-LIPS4	Obtain a transfer license key for LIPS4 in transfer invalidation.	2
ST-PSPCL	Display the installation status of PS and PCL in transfer invalidation.	2
TR-PSPCL	Obtain a transfer license key for PS and PCL in transfer invalidation.	2
ST-PCLUF	Display the installation status of PCL and UFR in transfer invalidation.	2
TR-PCLUF	Obtain a transfer license key for PCL and UFR in transfer invalidation.	2
ST-PSLIP	Display the installation status of PS and LIPS in transfer invalidation.	2

COPIER > OPTION > LCNS-TR		
Sub-item	Description	Level
TR-PSLIP	Obtain a transfer license key for PS and LIPS in transfer invalidation.	2
ST-PSPCU	Display the installation status of PS, PCL, and UFR in transfer invalidation.	2
TR-PSPCU	Obtain a transfer license key for PS, PCL, and UFR in transfer invalidation.	2
ST-LXUFR	Display the installation status of LIPS LX (UFR II for overseas) in transfer invalidation.	2
TR-LXUFR	Obtain a transfer license key for LIPS LX (UFR II for overseas) in transfer invalidation.	2
ST-HDCR2	Display the installation status of complete HDD deletion in transfer invalidation.	2
TR-HDCR2	Obtain a transfer license key for complete HDD deletion in transfer invalidation.	2

## 17.6.2 FEEDER

### 17.6.2.1 FEEDER List

iR5065 / iR 5055 / iR5075 / iR5075N / iR5065N / iR5055N

T-17-59

COPIER > FEEDER > OPTION		
Sub-item	Description	Level
SIZE-SW	Use it to enable detection of a mix of AB and inch originals. setting 0: ON (do not detect; default); 1: OFF (detect)	1
LS-DBL	Use it to enable/disable ADF high-speed duplex mode. setting 0: enable (execute high-speed duplex mode; normal mode; default) 1: disable (do not execute high-speed duplex mode; low-speed duplex mode)	1
STAMP-SW	Use it to indicate the presence/absence of a stamp. (If fitted, set '1' for STAMP-SW). setting 0: stamp absent 1: stamp present (default)	1

## 17.6.3 SORTER

### 17.6.3.1 SORTER List

iR5065 / iR 5055 / iR5075 / iR5075N / iR5065N / iR5055N

T-17-60

COPIER > SORTER > OPTION		
Sub-item	Description	Level
BLNK-SW	Use it to set the margin width on both sides of a crease when the saddle stitcher is in use. setting 0: normal width (5 mm) 1: extra width (10 mm; default)	1
MD-SPRTN	Use it to enable/disable accessory-independent mode in the event of a finisher error. setting 0: normal (disable accessory-independent mode; default) 1: enable (do not staple or align)	1

## 17.6.4 BOARD

### 17.6.4.1 BOARD List

iR5065 / iR 5055 / iR5075 / iR5075N / iR5065N / iR5055N

T-17-61

COPIER > BOARD > OPTION		
Sub-item	Description	Level
FONTDL	Use it to enable/disable display of the setting screen for font service when the PS kanji font downloaded is in use. setting 0: disable (do not display; default) 1: enable (display)	1

COPIER > BOARD > OPTION		
Sub-item	Description	Level
MENU-1 to 4	Use it to enable/disable display of levels 1 through 4 for the printer settings menu. setting 0: disable (do not display; default) 1: enable (display)	2

## 17.7 TEST (Test Print Mode)

### 17.7.1 COPIER

#### 17.7.1.1 COPIER List

iR5065 / iR 5055 / iR5075 / iR5075N / iR5065N / iR5055N

<PG>

T-17-62

COPIER > TEST > PG		
Sub-item	Description	Level
TYPE	Enter the type No. of the desired test print, and press the Start key to print out a test print. (Be sure to return it to '0' after printing.) 0: image from CCD (normal print) 1: grid 2: 17 gradations (error diffusion; T-BIC) 3: 17 gradations (dither screen) 4: blank 00H 5: halftone 80 H (error diffusion; T-BIC) 6: halftone 80 H (dither screen) 7: solid black FFH 8: horizontal line (space: 27 dots; line width: 4 dots) 9: horizontal line (space: 50 dots; line width: 6 dots) 10: horizontal line (space: 3 dots; line width: 2 dots) 11: halftone 60H (error diffusion; T-BIC) 12: halftone 60H (dither screen) 13: halftone 30H (error diffusion; T-BIC) 14: halftone 30H (dither screen) 15: 17 gradations (text mode) 16: 17 gradations (text/photo mode) 17: 17 gradations (print photo mode) 18: 17 gradations (film photo mode) 19: for R&D 20: 17 gradations (PDL screen: medium resolution) 21: 17 gradations (PDL screen: low resolution) 22: 17 gradations (PDL screen: high resolution) 23 to 30: for R&D	1
TXPH	Use it to switch between text mode or photo mode for test printing. setting: 0 to 4	1
PG-PICK	Use it to select the source of paper for test printing. 1: right deck 2: left deck 3: cassette 3 4: cassette 4 5-6: not used 7: side deck 8: multifeder	1
2-SIDE	Use it to select the output mode for test printing. setting 0: simplex 1: duplex (at time of shipment/upon RAM initialization: 0)	1
PG-QTY	Use it to select the output mode for test printing. Use it to set a copy count for test printing. 1 to 999 (default: 1)	1

<NETWORK>

T-17-63

COPIER > TEST > NETWORK		
Sub-item	Description	Level
PING	Use it to check the connection between the machine and a network (only if TCP/IP). Use it when checking the connection at time of installation or in the event of a network connection fault.	1

- 1) Hold down the control panel switch to start shut-down sequence. When ready, turn off the main power switch.
- 2) Connect the network cable to the machine, and turn on the main power switch.
- 3) Inform the user's system administrator that the installation of the machine is over, and ask him/her to make network settings.

- 4) Inform the system administrator that you are going to check the network connection, and find out the remote host address (i.e., the IP address of a PC terminal on the user's network).
- 5) Make the following selections in service mode: COPIER>TEST>NETWORK>PING; then, type in the IP address you obtained in step 4) When ready, press the OK key and then the Start key.
  - The indication will be 'OK' if the connection to the network is correct. (End the work.)
  - If the indication is 'NG', on the other hand, check the connection of the network cable; if the cable is normal, go to step 6). If a fault is found in the cable, correct it, and go back to step 5).
- 6) Make the following selections in service mode: COPIER>TEST>NETWORK>PING. Then, enter the local host address (i.e., IP address of the machine), and press the OK key.
  - If the indication is 'NG', suspect a fault in the IP address of the machine or of the network controller. Ask the system administrator for a check on the IP address, or replace the main controller PCB.
  - If the indication is 'OK', on the other hand, the network settings and the network controller may be assumed to be normal. If so, suspect a fault in the user's network environment; report to the system administrator for remedial work.
- 7) Make the following selections in service mode: COPIER>TEST>NETWORK>PING; then, enter the local host address (i.e., IP address of the machine), and press the OK key.
  - If the notation is 'NG', suspect a fault in the IP address of the machine or in the network controller. Contact the system administrator to obtain the correct IP address or replace the main controller PCB.
  - If the notation is 'OK', the network settings and the network controller may be assumed to be free of faults. The fault is likely to be in the user's network environment. Contact the system administrator for remedial action.

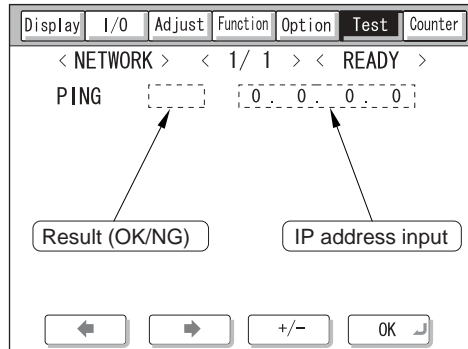

F-17-15

## 17.8 COUNTER (Counter Mode)

### 17.8.1 COPIER

#### 17.8.1.1 COPIER List

iR5065 / iR 5055 / iR5075 / iR5075N / iR5065N / iR5055N

<TOTAL>

T-17-64

COPIER > COUNTER > TOTAL		
Sub-item	Description	Level
<b>SERVICE1</b>	total counter 1 for service Increases the count when paper is discharged outside the machine. (regardless of the size of paper, i.e., large or small) after 99999999, resets to 00000000	1
<b>SERVICE2</b>	total counter 2 for service Increases the count when paper is discharge outside the machine. (in the case of large size, increases by 2; in the case of small size, increases by 1) after 99999999, resets to 00000000	1
<b>COPY</b>	total copy counter Increases the count when copying is over and the paper is discharged outside the machine. after 99999999, resets to 00000000	1
<b>PDL-PRT</b>	PDL print counter Increases the count when paper is discharged outside the machine or duplex stacking occurs to suit the charge counter in PDL print mode. in the case of a blank sheet, the count remains unchanged; for both large and small sizes, the count is increased by 1 after 99999999, resets to 00000000	1
<b>FAX-PRT</b>	fax reception print counter Increases the count when paper is discharged outside the machine or duplex stacking occurs to suit the charge counter in fax reception mode. in the case of a blank sheet, the count remains unchanged; for both large and small sizes, the count is increased by 1; the reading may be reset after 99999999, resets to 00000000	1
<b>RMT-PRT</b>	remote print counter Increases the count when paper is discharged outside the machine or duplex stacking occurs to suit the charge counter in remote print mode. in the case of a blank sheet, the count remains unchanged; for both large and small sizes, the count is increased by 1; the reading may be reset after 99999999, resets to 00000000	1

COPIER > COUNTER > TOTAL		
Sub-item	Description	Level
<b>BOX-PRT</b>	box print counter Increases the count when paper is discharged outside the machine or duplex stacking occurs to suit the charge counter in box print mode. in the case of a blank sheet, the count remains unchanged; for both large and small sizes, the count is increased by 1; the reading may be reset after 99999999, resets to 00000000	1
<b>RPT-PRT</b>	report print counter Increases the count when paper is discharged outside the machine or duplex stacking occurs to suit the charge counter in report print mode. in the case of a blank sheet, the count remains unchanged; for both large and small sizes, the count is increased by 1; the reading may be reset after 99999999, resets to 00000000	1
<b>2-SIDE</b>	duplex copy/print counter Increases the count when paper is discharged outside the machine or when duplex stacking occurs to suit the charge counter and to indicate the number of duplex copies/prints. in the case of a blank sheet, the count remains unchanged; for both large and small sizes, the count is increased by 1; the reading may be reset after 99999999, reset to 00000000	1
<b>SCAN</b>	scan counter Increases the count when an original has been read, indicating the number of originals read. for both large and small sizes, the count is increased by 1; the reading may be reset after 99999999, resets to 00000000	1

## &lt;PICKUP&gt;

T-17-65

COPIER > COUNTER > PICKUP		
Sub-item	Description	Level
<b>C1/2/3/4</b>	cassette 1/2/3/4 pickup total counter Indicates the number of sheets picked up from the cassette 1 (right deck)/2 (left deck)/3/4. after 99999999, resets to 00000000	1
<b>MF</b>	manual feeder pickup total counter Indicates the number of sheets picked up from the manual feed pickup unit. after 99999999, resets to 00000000	1
<b>DK</b>	deck pickup total counter Indicates the number of sheets picked up from the deck pickup unit. after 99999999, resets to 00000000	1
<b>2-SIDE</b>	duplex pickup total counter Indicates the number of sheets picked up for duplexing. after 99999999, resets to 00000000.	1

## &lt;FEEDER&gt;

T-17-66

COPIER > COUNTER > FEEDER		
Sub-item	Description	Level
<b>FEED</b>	ADF original pick total counter	1
<b>DFOP-CNT</b>	Indicates the number of times the ADF hinge has opened/closed. setting 0: OFF (default) 00000000 to 99999999	1

## &lt;JAM&gt;

T-17-67

COPIER > COUNTER > JAM		
Sub-item	Description	Level
<b>TOTAL</b>	total jam counter	1
<b>FEEDER</b>	feeder total jam counter	1
<b>SORTER</b>	finisher total jam counter	1
<b>2-SIDE</b>	duplexing unit jam counter	1
<b>MF</b>	manual feed pickup jam counter	1
<b>C1/2/3/4</b>	right deck/left deck/cassette 3/cassette 4 jam counter	1
<b>DK</b>	side paper deck jam counter	1

## &lt;MISC&gt;

## T-17-68

COPIER > COUNTER > MISC		
Sub-item	Description	Level
FIX-WEB	fixing web counter (Be sure to reset the counter when the fixing web has been replaced.)	1
WST-TNR	collecting toner counter (Be sure to reset the counter when collecting toner has been disposed of.)	1
ALLPW-ON	Non-all-night startup counter (Clear at replacing the power supply)  Only supports iR5075/5065/5055 Series V2. (BODY No. CHL XXXX, CHM XXXX, CHN XXXX, CHP XXXX, CHQ XXXX, CHU XXXX, CHV XXXX, CHW XXXX, CHZ XXXX, CJA XXXX, CJD XXXX, CJE XXXX, CJK XXXX, CJP XXXX, CJQ XXXX, CJR XXXX, CJU XXXX, CJZ XXXX, CKA XXXX, CKC XXXX, CKD XXXX, CKE XXXX)	1
HDD-ON	HDD startup counter (Clear at replacing the HDD)  Only supports iR5075/5065/5055 Series V2. (BODY No. CHL XXXX, CHM XXXX, CHN XXXX, CHP XXXX, CHQ XXXX, CHU XXXX, CHV XXXX, CHW XXXX, CHZ XXXX, CJA XXXX, CJD XXXX, CJE XXXX, CJK XXXX, CJP XXXX, CJQ XXXX, CJR XXXX, CJU XXXX, CJZ XXXX, CKA XXXX, CKC XXXX, CKD XXXX, CKE XXXX)	1

## &lt;PRDC-1&gt;

## T-17-69

COPIER > COUNTER > PRDC-1		
Sub-item	Description	Level
PRM-WIRE	primary charging wire counter	1
PRM-GRID	primary grid wire counter	1
PO-WIRE	pre-transfer charging wire counter	1
TR-WIRE	transfer charging wire counter	1
SP-WIRE	separation charging wire counter	1
PRM-CLN	primary charging wire cleaner counter	1
TR-CLN	transfer charging wire cleaner counter	1
PO-CLN	pre-transfer charging wire cleaner counter	1
SP-CLN	separation charging wire cleaner counter	1
TR-CLN2	transfer charging wire cleaner 2 counter	1
FIX-TH1	fixing main thermistor (THM1) counter	1
FIX-TH2	fixing sub thermistor (THM2) counter	1
OZ-FIL1	ozone filter	1
AR-FIL1	air filter 1	1
AR-FIL2	air filter 2	1

## &lt;DRBL-1&gt;

## T-17-70

COPIER > COUNTER > DRBL-1		
Sub-item	Description	Level
PRM-UNIT	primary charging assembly counter	1
PO-UNIT	pre-transfer charging assembly counter	1
PO-SCRPR	pre-transfer charging assembly scraper counter	1
T/S-UNIT	transfer/separation charging assembly counter	1
CLN-BLD	cleaner blade counter	1
SP-CLAW	cleaner separation claw counter	1
DVG-CYL	developing cylinder counter	1
DVG-ROLL	developing spacer counter	1
C3-PU-RL	cassette 3 pickup roller counter	1
C3-SP-RL	cassette 3 separation roller counter	1
C3-FD-RL	cassette 3 feed roller counter	1
C4-PU-RL	cassette 4 pickup roller counter	1
C4-SP-RL	cassette 4 separation roller counter	1
C4-FD-RL	cassette 4 feed roller counter	1
LD-PU-RL	left front deck pickup roller counter	1
LD-SP-RL	left front deck separation roller counter	1
LD-FD-RL	left front deck feed roller counter	1
RD-SP-RL	right front deck separation roller counter	1
RD-FD-RL	right front deck feed roller counter	1
RD-PU-RL	right front deck pickup roller counter	1
M-SP-RL	manual feed tray separation roller counter	1
M-FD-RL	manual feed tray feed roller counter	1
FX-UP-RL	fixing roller counter	1
FX-LW-RL	pressure roller counter	1
FX-IN-BS	fixing heat insulating bush counter	1

COPIER > COUNTER > DRBL-1		
Sub-item	Description	Level
FX-WEB	Indicates the number of times the fixing web has been taken up. If you have replaced the web, be sure to reset the reading in service mode: COPIER>COUNTER>MISC>FIX-WEB, COPIER>COUNTER>DRBL-1>FX-WEB.	1
DLV-UCLW	delivery upper separation claw counter	1
DLV-LCLW	delivery lower separation claw counter	1

&lt;DRBL-2&gt;

T-17-71

COPIER > COUNTER > DRBL-2		
Sub-item	Description	Level
DF-PU-RL	Indicates the number of sheets picked up by the ADF pickup roller. (counter reading retained by the controller PCB) for both simplex and duplex modes, the count is increased by 1 (regardless of the number of sides); also, there is no distinction between large and small sizes	1
DF-SP-PL	Indicates the number of sheets separated by the ADF separation pad. setting rage/setting item 00000000 to 99999999	1
DF-SP-PD	Indicates the number of sheets separated by the ADF separation pad. (counter reading retained by the controller PCB) for both simplex and duplex modes, the count is increase by 1 (regardless of the number of sides); also, there is no distinction between large and small sizes	1
DF-FD-RL	Indicates the number of sheets feeded by the ADF feed roller. (counter reading retained by the controller PCB) in the case of simplex mode, the count is increased by 1 for each original read; in the case of duplex mode, the count is increased by 3 for each original read (to accommodate 3 feeding sessions, i.e., face, back, and idle); there is no distinction between large and small sizes	1
LNT-TAP1	Indicates the number of sheets moving past the ADF dust-collecting tape. for both simplex and duplex modes, the count is increased by 1 for each original read (not its sides)	1
LNT-TAP2	Indicates the number of sheets moving past the ADF dust-collecting tape. for both simplex and duplex modes, the count is increased by 1 for each original read (not its sides)	1
LNT-TAP3	Indicates the number of sheets moving past the ADF dust-collecting tape. for both simplex and duplex modes, the count is increased by 1 for each original read (not its sides)	1
LNT-TAP4	Indicates the number of sheets moving past the ADF dust-collecting tape. for both simplex and duplex modes, the count is increased by 1 for each original read (not its sides)	1
LNT-TAP5	Indicates the number of sheets moving past the ADF dust-collecting tape. for both simplex and duplex modes, the count is increased by 1 for each original read (not its sides)	1
STAMP	number of times the stamp solenoid has gone on	1
PD-PU-RL	Indicates the number of sheets moving past the paper deck pickup roller. (counter reading retained by the controller PCB)	1
PD-SP-RL	Indicates the number of sheets moving past the paper deck separation roller. (counter reading retained by the controller PCB)	1
PD-FD-RL	Indicates the number of sheets moving past the controller PCB. (counter reading retained by the controller PCB)	1
SORT	Sort counter The large and small sizes are not distinguished from each other.	1
FIN-STPR	stapler (handling tray assembly)	1
SADDLE	Saddle paper transport counter The large and small sizes are not distinguished from each other.	1
SDL-STPL	Indicates the number of times the stapler (saddle assembly) has operated. (counter reading retained by the DC controller PCB)	1
PUNCH	Punching counter	1
FIN-BFFRL	Indicates the number of times the puncher has swung.	1





---

## Chapter 18 Upgrading

---



---

# Contents

18.1 Outline.....	18-1
18.1.1 Outline of Upgrading the Machine .....	18-1
18.1.2 Outline of the Service Support Tool .....	18-1
18.2 Making Preparations .....	18-4
18.2.1 Registering the System Software .....	18-4
18.2.2 Making Connections .....	18-6
18.3 Formatting the HDD .....	18-8
18.3.1 Formatting All Partitions .....	18-8
18.3.2 Formatting Selected Partitions .....	18-9
18.3.3 Formatting the Partitions.....	18-9
18.4 Downloading System Software.....	18-11
18.4.1 Downloading System.....	18-11
18.4.1.1 Outline.....	18-11
18.4.1.2 Downloading Procedure.....	18-11
18.4.2 Downloading RUI, and Language .....	18-13
18.4.2.1 Outline.....	18-13
18.4.2.2 Downloading Procedure.....	18-15
18.4.3 Downloading SDICT .....	18-16
18.4.3.1 Outline.....	18-16
18.4.3.2 Downloading Procedure.....	18-16
18.4.4 Downloading MEAPCONT.....	18-18
18.4.4.1 Outline.....	18-18
18.4.4.2 Downloading Procedure.....	18-18
18.4.5 Downloading KEY.....	18-19
18.4.5.1 Outline.....	18-19
18.4.5.2 Downloading Procedure.....	18-20
18.4.6 Downloading the TTS.....	18-21
18.4.6.1 Outline.....	18-21
18.4.6.2 Downloading Procedure.....	18-21
18.4.7 Downloading BOOT.....	18-22
18.4.7.1 Outline.....	18-22
18.4.7.2 Downloading Procedure.....	18-23
18.4.8 Downloading Dcon and Rcon.....	18-24
18.4.8.1 Outline.....	18-24
18.4.8.2 Downloading Procedure.....	18-25
18.4.9 Downloading G3 FAX.....	18-26
18.4.9.1 Outline.....	18-26
18.4.9.2 Downloading Procedure.....	18-27
18.4.10 Uploading and Downloading Backup Data .....	18-28
18.4.10.1 Outline.....	18-28
18.4.10.2 Uploading Procedure.....	18-29
18.4.10.3 Downloading Procedure.....	18-31



## 18.1 Outline

### 18.1.1 Outline of Upgrading the Machine

iR5065 / iR 5055 / iR5075 / iR5075N / iR5065N / iR5055N

The machine and its accessories may be upgraded by replacing DIMM-ROM or using the Service Support Tool (hereafter, SST) installed on a personal computer (PC).

The following table shows the various system software used in conjunction with the machine and how they may be upgraded.

T-18-1

Type	Type of system software	Method of upgrading		Remarks
		SST	ROM-DIMM replacement	
Machine				
	System (main controller)	Yes	No	The machine controller is also used to control the Super G3 Fax Board.
	Language (language mode)	Yes	No	
	RUI (remote user interface)	Yes	No	
	Boot (boot program)	Yes	Yes	
	MEAP CONT (MEAP library)	Yes	No	
	SDICT (OCR dictionary)	Yes	No	
	KEY (encryption communication key)	Yes	No	
	TTS (voice dictionary)	Yes	No	
	DCON (DC controller)	Yes	No	
	RCON (reader controller)	Yes	No	The reader controller is also used to control the ADF.
Accessory				
	Multi-FAX Board	Yes	Yes	
	Fin_A series (Finisher-AD1/Saddle Finisher-AE2)	Yes	No	A special service tool (downloader PCB: FY9-2034) is needed.
	DADF-S1	Yes Ver.3.3 or later	No	A special service tool (downloader PCB: FY9-2034) is needed.

### 18.1.2 Outline of the Service Support Tool

iR5065 / iR 5055 / iR5075 / iR5075N / iR5065N / iR5055N

The Service Support Tool (hereafter, SST) has the following functions:

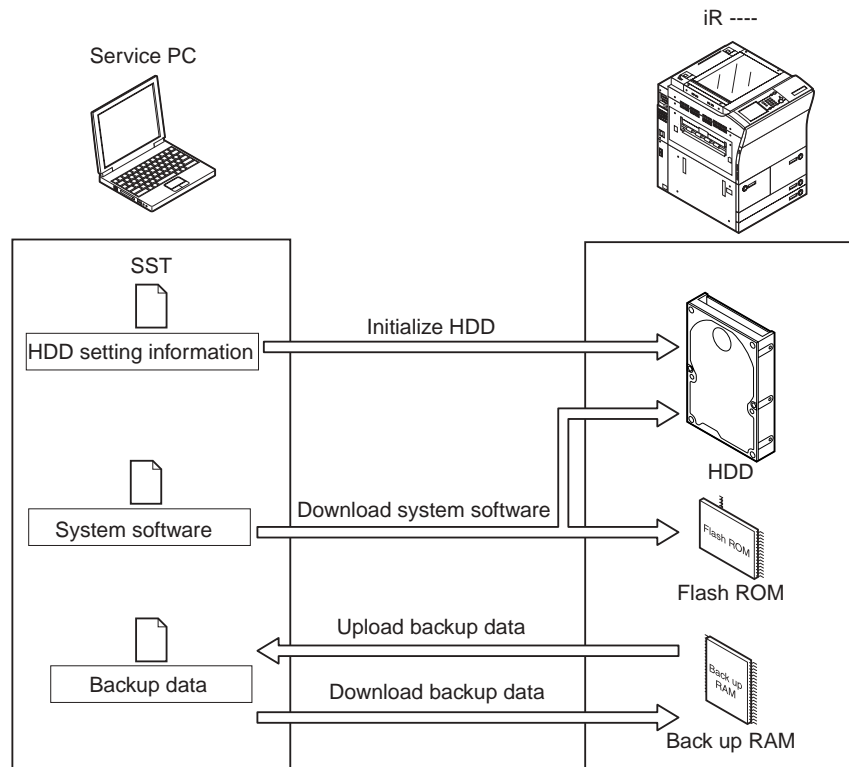

F-18-1

The machine must be in download mode when the SST is used.

The download control program comes in 2 types:

**-Normal Mode (download mode B)**

turn on the main power while holding down 1+7; then, make the following selections in service mode: COPIER>FUNCTION>SYSTEM>DOWNLOAD

**-Safe Mode(download mode A)**

turn on the main power while holding down 2+8

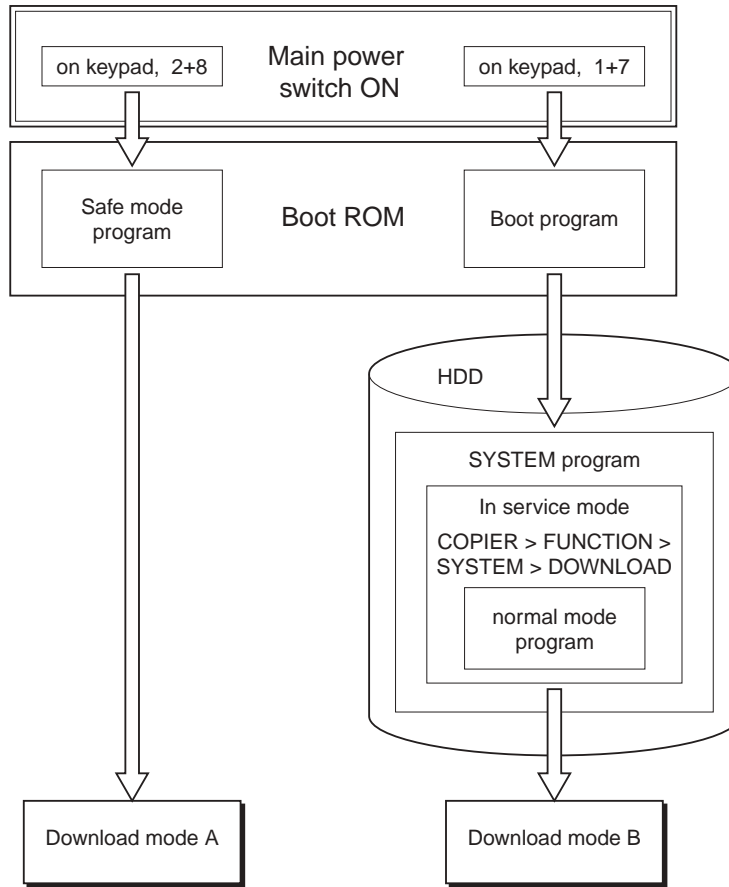

F-18-2



Use safe mode for the following:

- when you have replaced the HDD.
- when the system fails to start up normally.

The following table shows the functions that may be used in download mode with the SST in use:

T-18-2

Function	Download mode	
	Normal mode (download mode B)	Safe mode (download mode A)
Formatting the HDD	- -	Entire HDD BOOTDEV
	FSTDEV TMP_GEN TMP_PSS TMP_FAX APL_SEND APL_MEAP APL_GEN PDL_DEV FSTCDEV	- - - - - - - -

Function	Download mode	
	Normal mode (download mode B)	Safe mode (download mode A)
Downloading the system software	-System -Language -RUI -Boot -G3FAX -Dcon -Rcon -SDICT -MEAPCONT -KEY -TTS	-System -Language -RUI -Boot - -Dcon -Rcon -SDICT -MEAPCONT -KEY -TTS
Uploading/downloading backup data	-	-SramImg -Meapback

**Installing the System Software**

The system software that has been downloaded by the SST (version 3.33 or later) is saved in the temporary storage area of the HDD. You must then turn off and then on the main power switch so that the system software will be written to the system area and flash ROM when the machine starts up. When you turn off and then on the main power switch for a second time, the machine will start up using the new version of the system software.

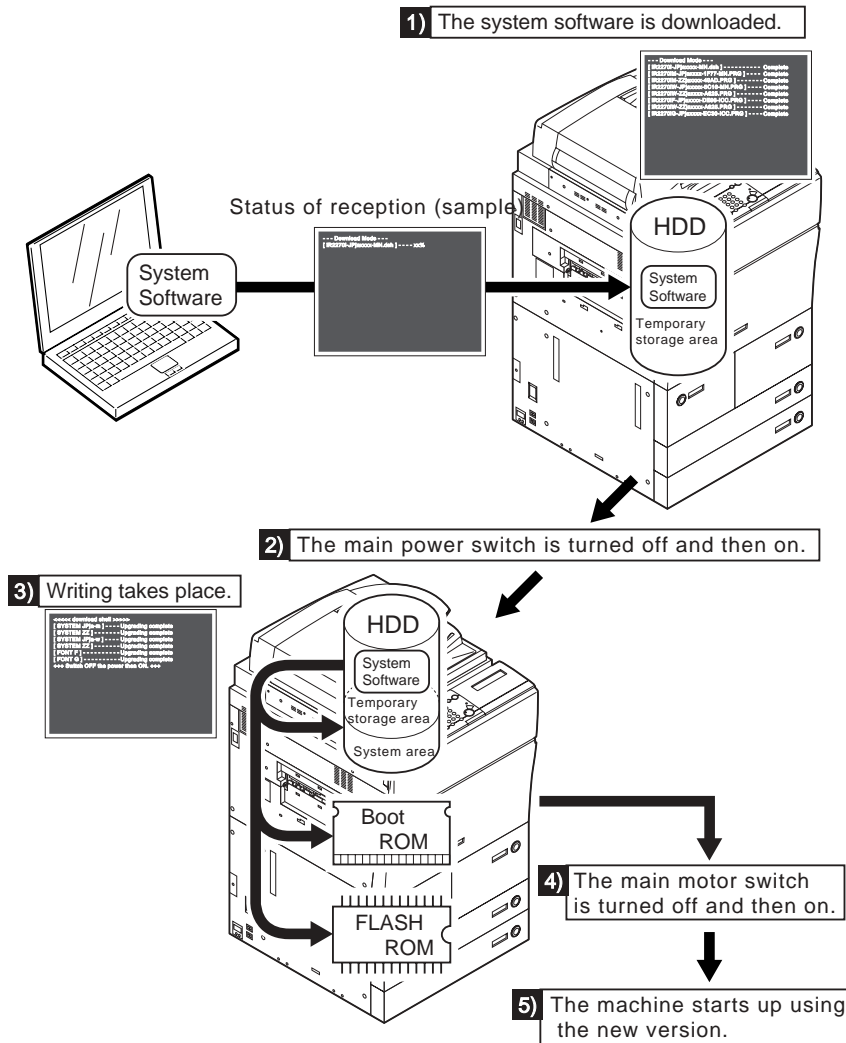

F-18-3

If a previous version of the SST is used for downloading, the system software will be written directly to the HDD, boot ROM, and flash ROM. The previous version of the SST is not enable to use for this model.

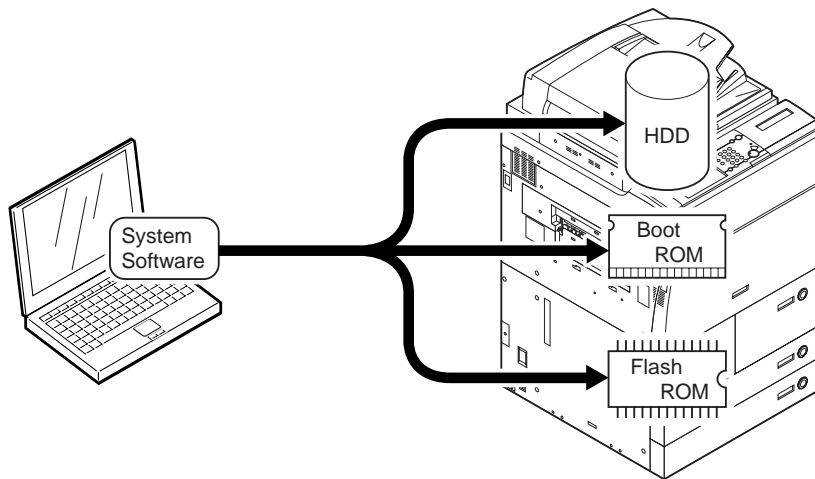

F-18-4

## 18.2 Making Preparations

### 18.2.1 Registering the System Software

iR5065 / iR 5055 / iR5075 / iR5075N / iR5065N / iR5055N

You must first register the system software found on the System CD to the SST.

[Preparatory Work]

Items to Prepare

- PC to which the SST (version 3.33 or later) has been installed
- System CD for the iR5075/5065/5055 Series

[Registering the System Software]

- 1) Start up the PC.
- 2) Set the system CD in the PC.
- 3) Start up the SST.
- 4) Click [Register System Software]

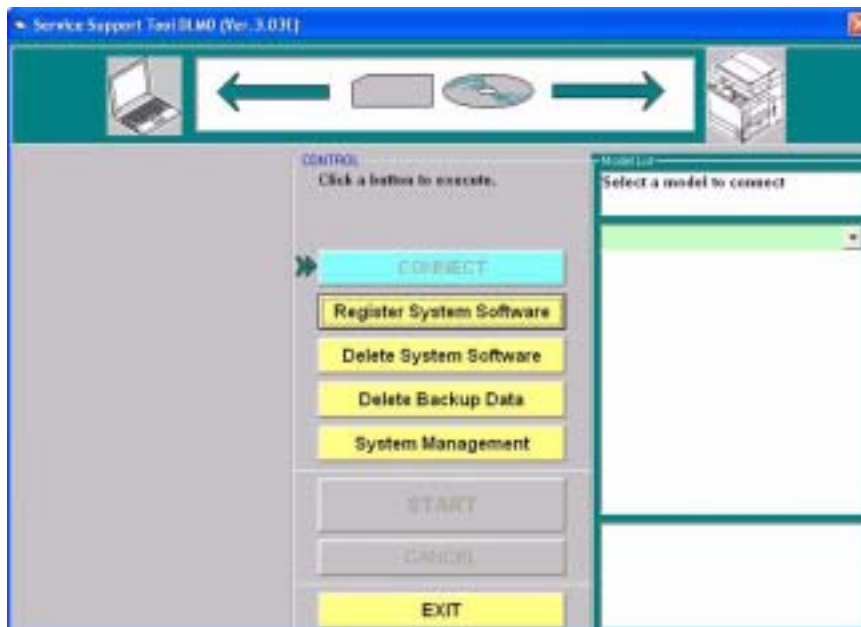

F-18-5

- 5) Select the drive in which you have set the System CD, and click [SEARCH].



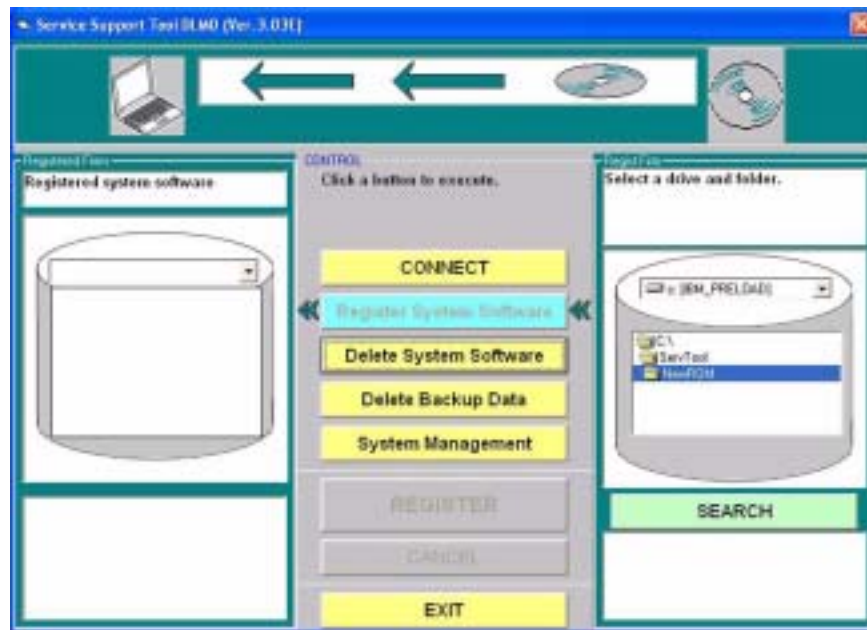

F-18-6

6) The list of system software found on the System CD appears. Remove the check from the folders and software you will not need; then, click [REGISTER].

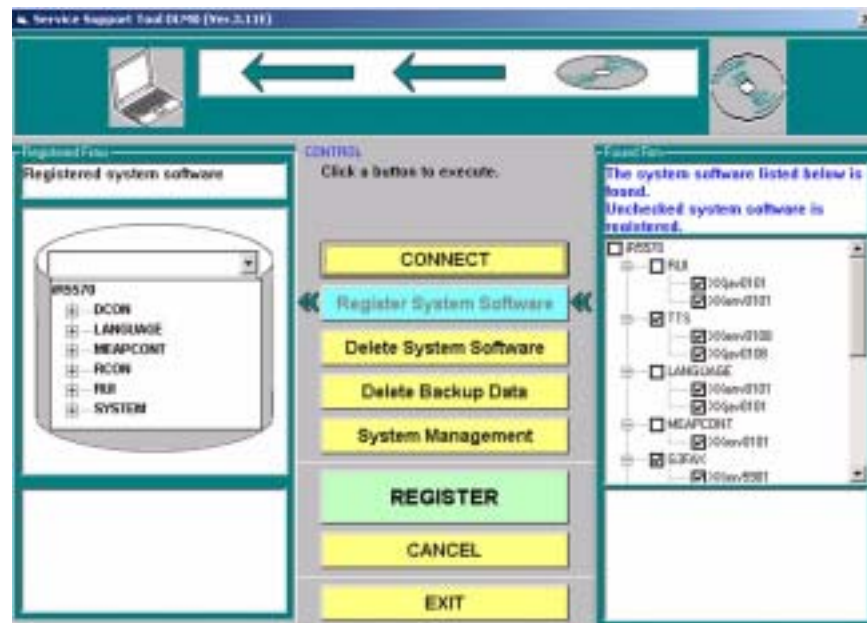

F-18-7

7) When the result of registration is indicated, click [OK].

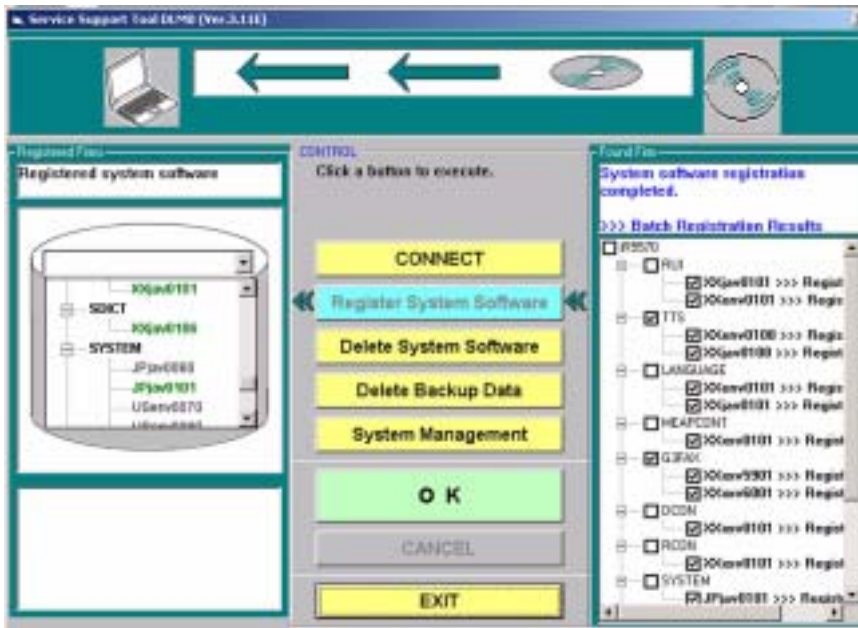

F-18-8

### 18.2.2 Making Connections

iR5065 / iR 5055 / iR5075 / iR5075N / iR5065N / iR5055N

You are now ready to connect the PC to the machine.

**[Preparatory Work]**

Items to Prepare

- PC to which the SST (version 3.33 or later) and the system software for the iR5075/5065/5055 series has been registered
- Twisted pair cross cable
- 10Base-T: Category 3 or 5
- 100Base-TX: Category 5

**[Procedure]**

- 1) Start up the PC.
- 2) Check the network settings of the PC.
  - At the command prompt, type 'IPCONFIG', and press the Return key.
  - Check to see that the network settings are as follows:  
 IP address: 172.16.1.160  
 subnet mask: 255.255.255.0  
 default gateway: any



Do not use the following IP address:

- 172.16.1.0
- 172.16.1.100
- 172.16.1.255

If the settings are not as indicated below, make the appropriate changes:

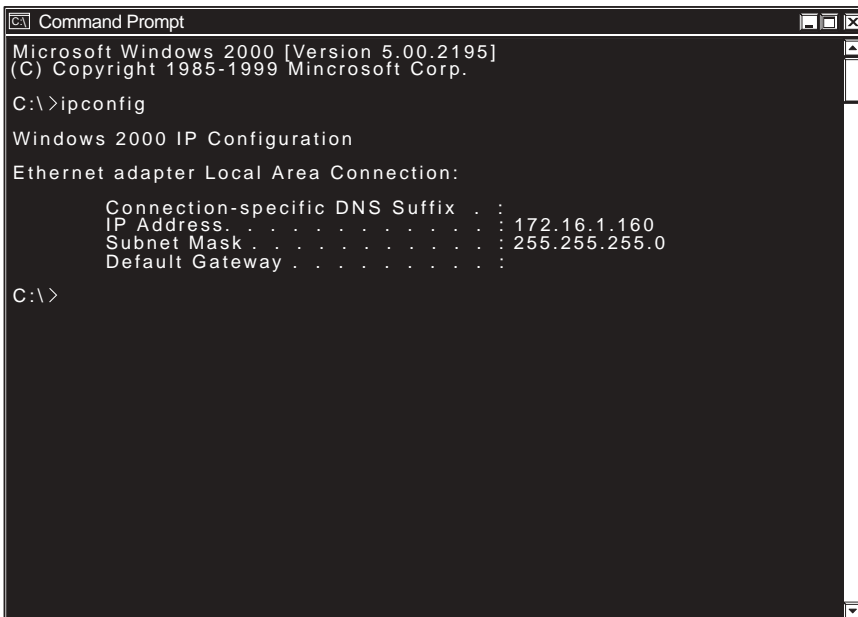

F-18-9

- 3) Check to see that the Execute/Memory lamp on the control panel is off, and turn off the main power switch.
  - 3-1) Hold down the power switch on the control panel for 3 sec or more.
  - 3-2) Follow the instructions indicated on the control panel so that the main power switch may be turned off.
  - 3-3) Turn off the main power switch.
- 4) Connect the PC to the machine using a cross cable.

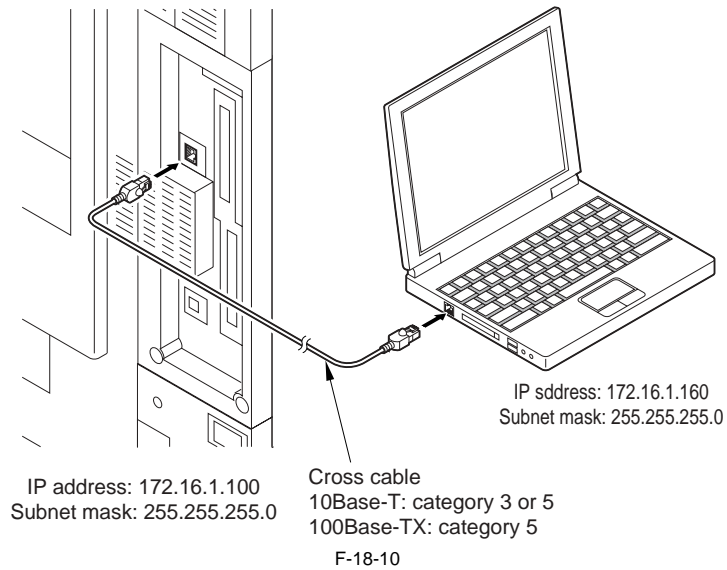

- 5) Start up the machine to suit the download mode you will be using.
  - **Normal Mode**  
Turn on the main power switch while holding down 1+7.  
When the machine has started up, make the following selections: COPIER > FUNCTION > SYSTEM > DOWNLOAD.
  - **Safe Mode**  
Turn on the main power switch while holding down 2+8.
- 6) Start up the Service Support Tool.
- 7) Select the model of the machine to connect.

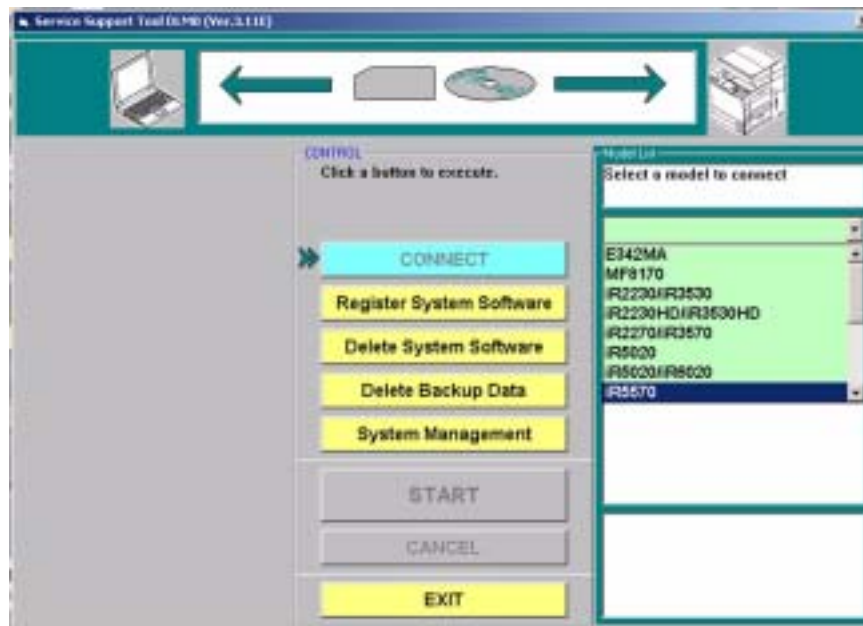

F-18-11

- 8) Click [START].



F-18-12

## 18.3 Formatting the HDD

### 18.3.1 Formatting All Partitions

iR5065 / iR 5055 / iR5075 / iR5075N / iR5065N / iR5055N

When you format all partitions of the HDD, all individual partitions will be initialized and made ready for use by the main controller. The information needed for partition settings is stored under HDFormat of the iRXXXX.

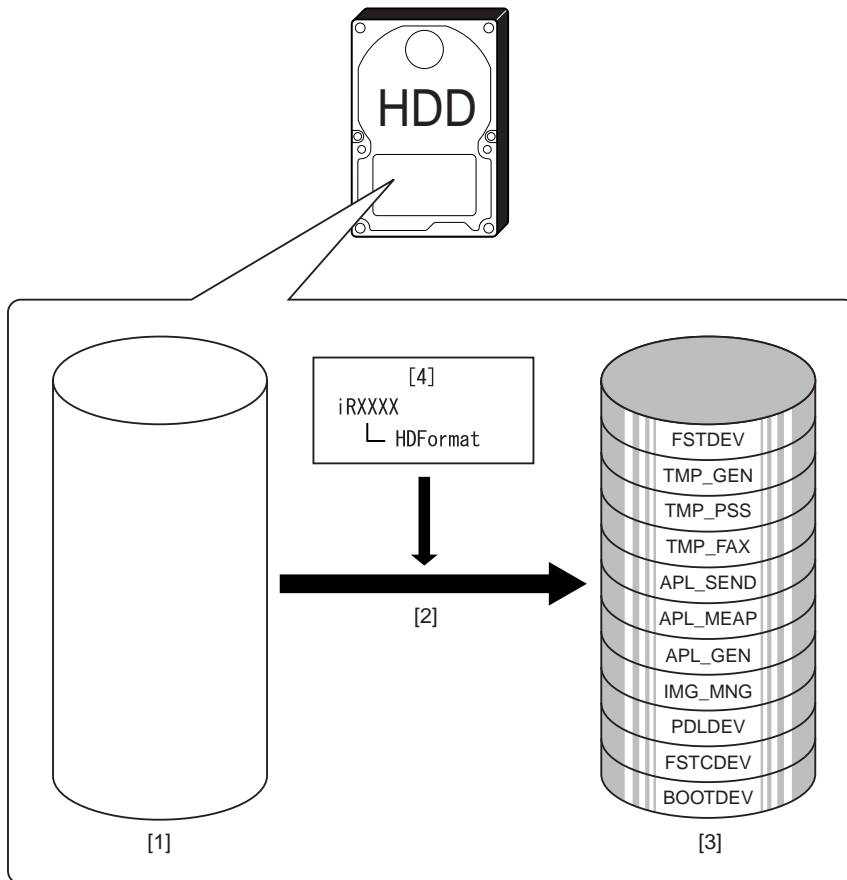

F-18-13

- [1] HDD (service part; without partition setup)
- [2] Formatting of all partitions (in safe mode only)
- [3] HDD after formatting
- [4] Partition setup information

### 18.3.2 Formatting Selected Partitions

iR5065 / iR 5055 / iR5075 / iR5075N / iR5065N / iR5055N

You can also format (initialize) only those partitions that you select.

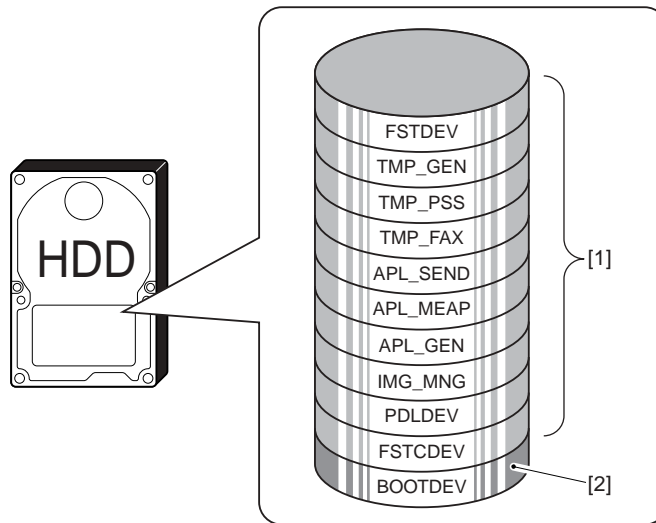

F-18-14

[1] Formatting possible in normal mode

[2] Formatting possible in safe mode (requires downloading of System and RUI after formatting)



1. Unless you have selected 'ALL', you may execute formatting without registering HDFormat.
2. An attempt to format after selecting TMP\_FAX in the absence of a fax board will cause an error.

### 18.3.3 Formatting the Partitions

iR5065 / iR 5055 / iR5075 / iR5075N / iR5065N / iR5055N

- 1) Click [Format HDD].

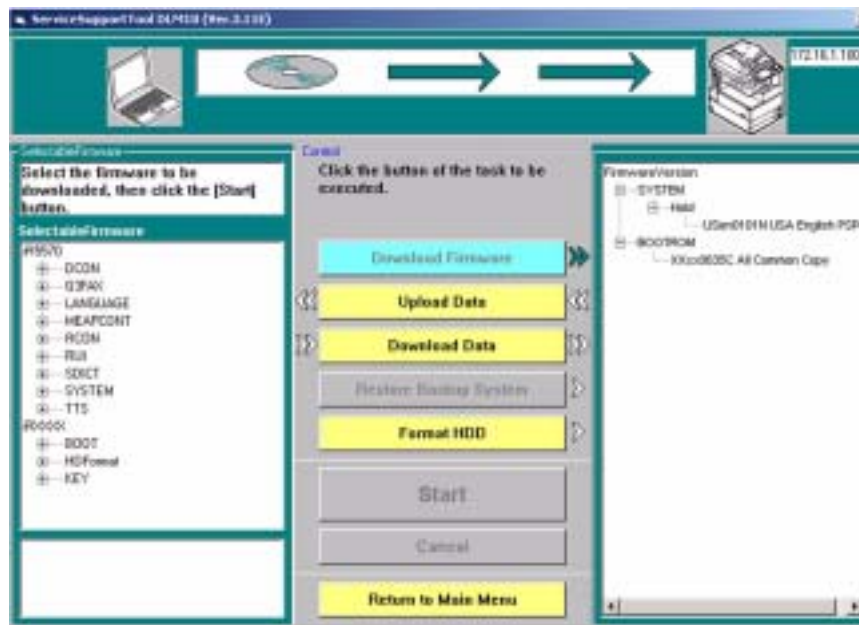

F-18-15

- 2) Select the partitions you want to format. Or, select 'ALL'.

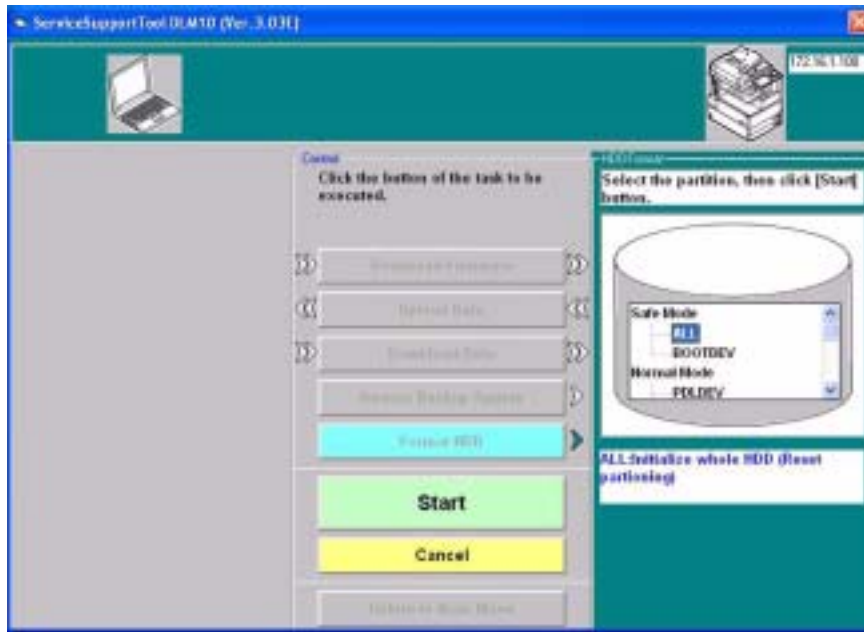

F-18-16

- 3) Click [Start].
- 4) When the Confirmation screen has appeared, click [Execute Formatting].



F-18-17

- 5) When the session has ended, click [OK].

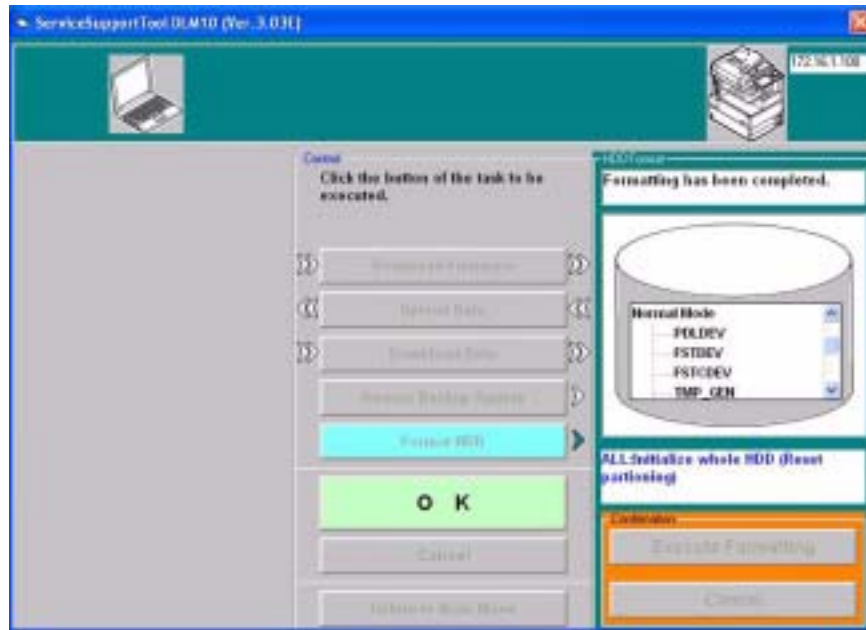

F-18-18

6) Start a download session. Or, turn off and then on the machine to end the work.



If you have formatted all partitions or formatted BOOTDEV, be sure to download System newly. (Otherwise, 'E602' will occur when you turn on the main power.)

## 18.4 Downloading System Software

### 18.4.1 Downloading System

#### 18.4.1.1 Outline

iR5065 / iR 5055 / iR5075 / iR5075N / iR5065N / iR5055N

The system software comes in 2 types (one for use inside Japan and the other, outside Japan).

Unlike previous iR controllers, however, there is only one type of system software. (Previously, one type supported NetWare while the other did not. There is now only one type for the machine supporting NetWare.)

#### 18.4.1.2 Downloading Procedure

iR5065 / iR 5055 / iR5075 / iR5075N / iR5065N / iR5055N

You can run a downloading session either in normal or safe mode.

- 1) Select the version of the system you want to download.

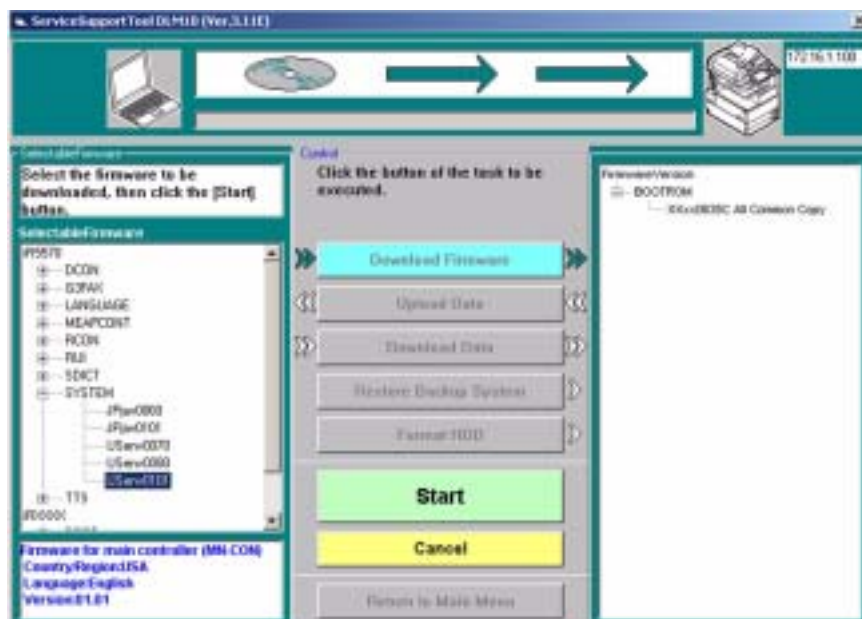

F-18-19

- 2) Click [Start].

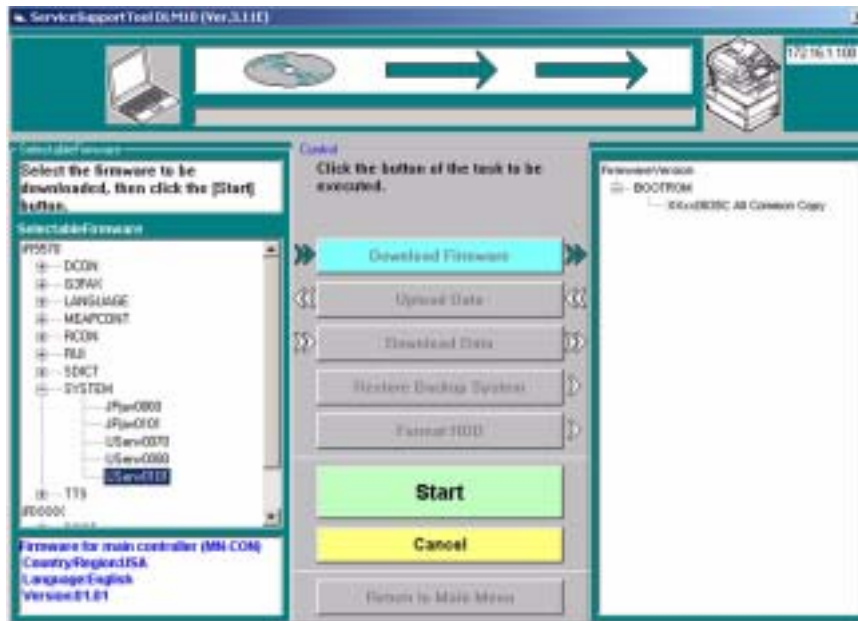

F-18-20

3) When the session has ended, click [OK].



F-18-21

4) If you want to start another downloading session, see the appropriate instructions.

5) When you are done with downloading, turn off and then on the main power.

6) See the upgrade status indicated on the control panel. When a message appears asking you to turn off and then on the switch, turn off and then on the main power.



Be sure never to turn off the power while the machine is executing a downloading session or writing downloaded software. The ongoing session will be suspended and the machine may fail to start up.





F-18-22

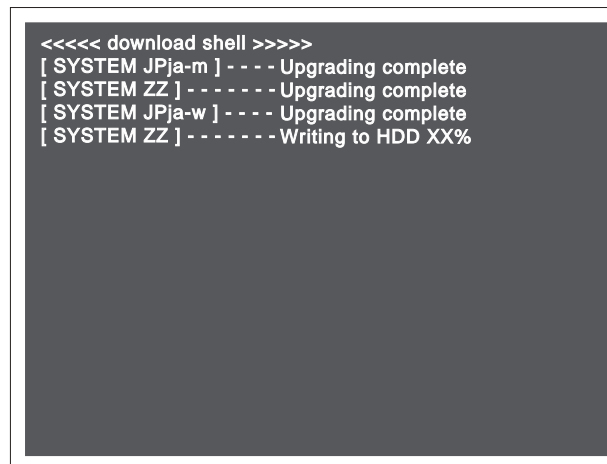

F-18-23

If the machine fails to start up, format BOOTDEV using HDFormat, and then download system software to be stored in the HDD such as System, Language, and RUI.

## 18.4.2 Downloading RUI, and Language

### 18.4.2.1 Outline

iR5065 / iR 5055 / iR5075 / iR5075N / iR5065N / iR5055N

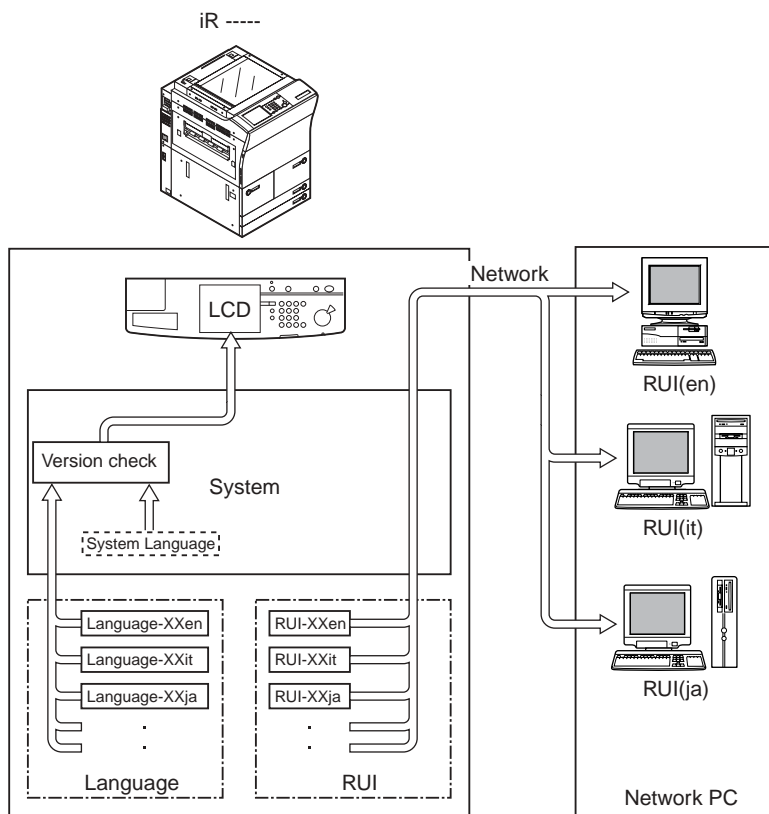

F-18-24  
T-18-3

**Control Panel LCD Display Language**

Check the version of System and Language.

1. If correct, You can switch languages by making the following selections in user mode: common settings>display language change.
2. If not correct, 'E744' will be indicated, and System Language will be used when the main power is turned off and then on.

T-18-4

**RUI Display Language**

Select using the RUI.  
You can select a different language for a different PC.

<Language Code>	<Language>
de	German
en	English
fr	French
it	Italian
ja	Japanese

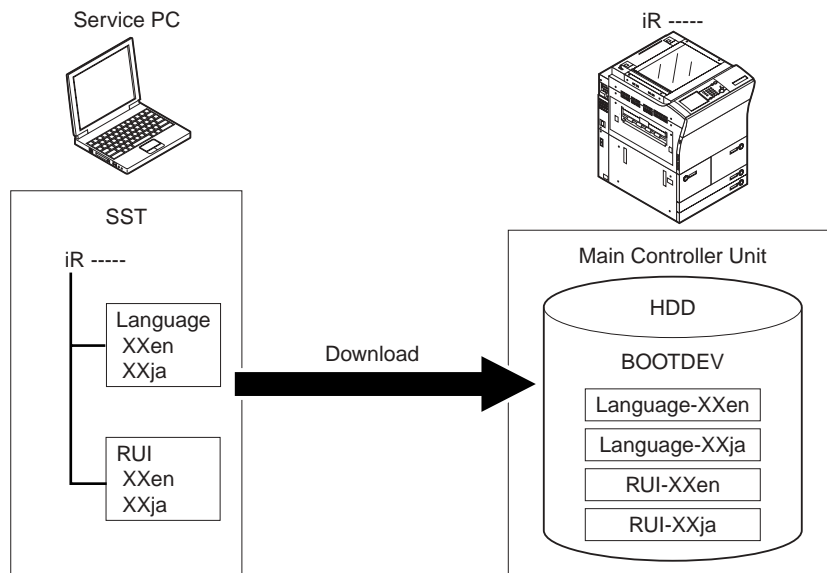

F-18-25

### 18.4.2.2 Downloading Procedure

iR5065 / iR 5055 / iR5075 / iR5075N / iR5065N / iR5055N

You can run a download session in either normal or safe mode.

[In the Case of Language]

- 1) Select the version of Language to download.

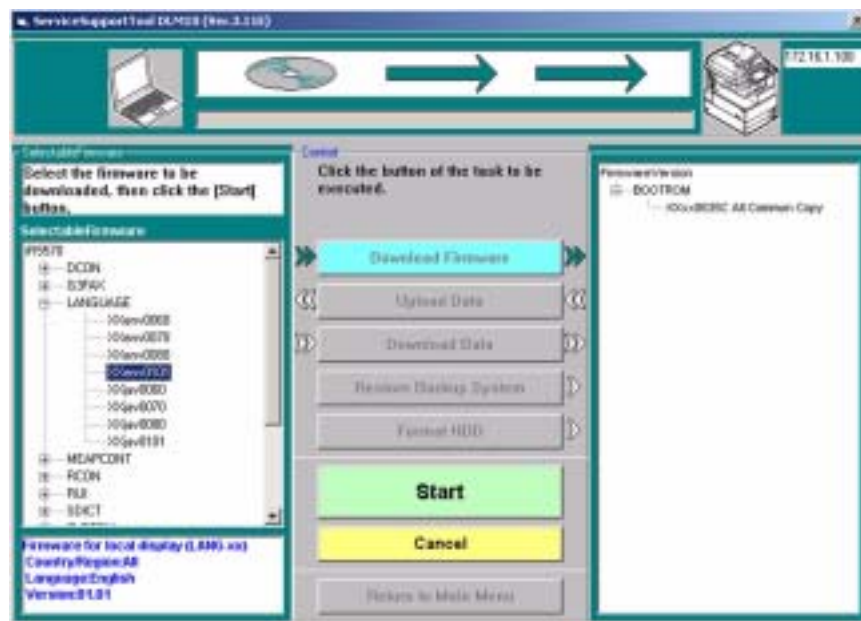

F-18-26

- 2) Click [Start].

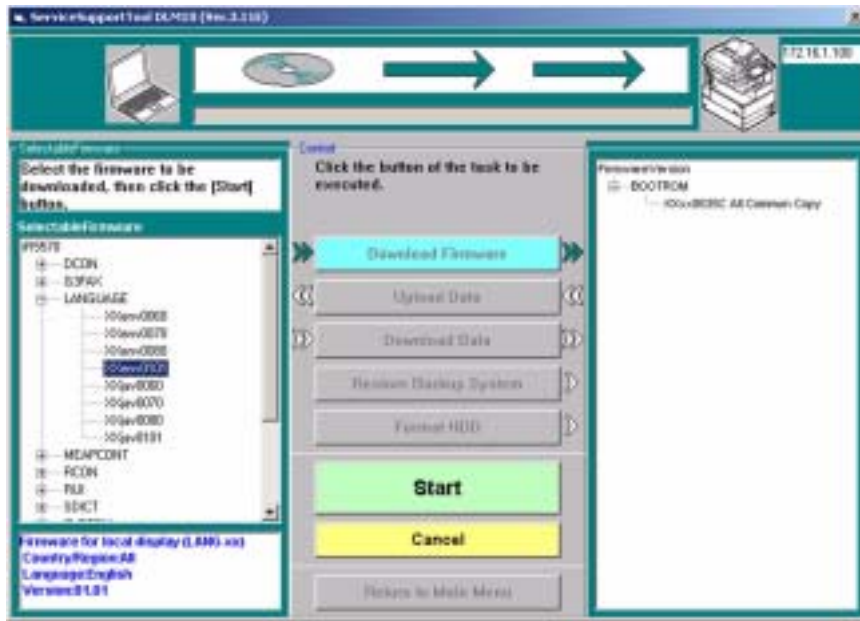

F-18-27

3) When the result of the downloading session has appeared, click [OK].

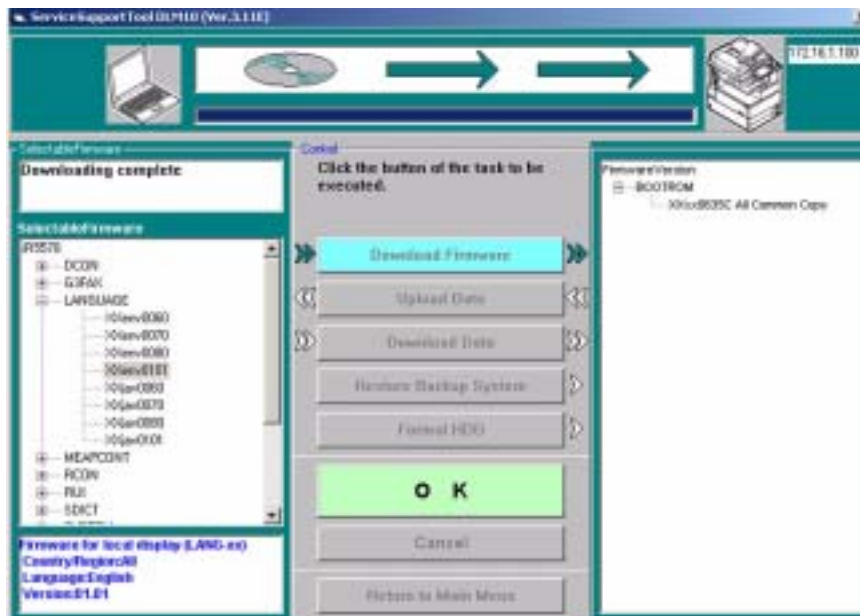

F-18-28

4) If you want another downloading session, see the appropriate instructions.

5) When you are done, turn off and then on the main power.

6) See the status of upgrading indicated on the control panel. When a message appears asking you to turn off and then on the machine, turn off and then on the main power.



Be sure never to turn off the power while the machine is executing a downloading session or writing downloaded software. Otherwise, the ongoing session will be suspended and the machine may fail to start up.  
If the machine fails to start up, format BOOTDEV using HDFORMAT, and then download system software to be stored in the HDD such as System, Language, and RUI.

### 18.4.3 Downloading SDICT

#### 18.4.3.1 Outline

iR5065 / iR 5055 / iR5075 / iR5075N / iR5065N / iR5055N

SDICT is a dictionary used when converting image data read by the reader unit into character code (OCR processing). This function is used in conjunction with the PDF Generation Expansion Kit.

#### 18.4.3.2 Downloading Procedure

iR5065 / iR 5055 / iR5075 / iR5075N / iR5065N / iR5055N

You can run a downloading session in either normal or safe mode.

- 1) Select the version of SDICT to download.

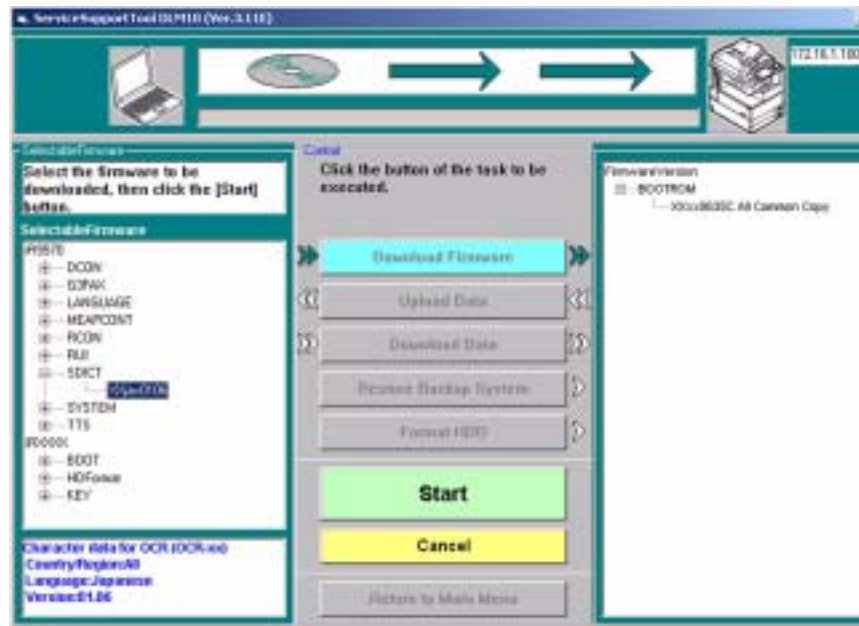

F-18-29

- 2) Click [Start].



F-18-30

- 3) When the session has ended, click [OK].



F-18-31

- 4) If you want to run another downloading session, see the appropriate instructions.
- 5) When you are done, turn off and then on the main power.
  - 6) See the status of upgrading indicated on the control panel. When a message appears asking you to turn off and then on the switch, turn off and then on the main power.

**⚠** Be sure never to turn off the machine while it is executing a downloading session or writing downloaded software. Otherwise, the ongoing session will be suspended and the machine may fail to start up. If the machine fails to start up, format BOOTDEV using HDFORMAT, and then download system software to be stored in the HDD such as System, Language, and RUI.

## 18.4.4 Downloading MEAPCONT

### 18.4.4.1 Outline

iR5065 / iR 5055 / iR5075 / iR5075N / iR5065N / iR5055N

MEAPCONT is a standard library used in conjunction with a MEAP application.

### 18.4.4.2 Downloading Procedure

iR5065 / iR 5055 / iR5075 / iR5075N / iR5065N / iR5055N

You can execute a downloading session in either normal or safe mode.

- 1) Select the version of MEAPCONT you want to download.



F-18-32

- 2) Click [Start].



F-18-33

3) When the downloading session has ended, click [OK].



F-18-34

4) If you want to run another downloading session, see the appropriate instructions.

5) When you are done, turn off and then on the main power.

6) See the status of upgrading indicated on the control panel. When a message appears asking you to turn off and then on the switch, turn off and then on the main power.



Be sure never to turn off the machine while it is executing a downloading session or writing downloaded software. Otherwise, the ongoing session will be suspended and the machine may fail to start up.

If the machine fails to start up, format BOOTDEV using HDFSFormat, and then download system software to be stored in the HDD such as System, Language, and RUI.

## 18.4.5 Downloading KEY

### 18.4.5.1 Outline

iR5065 / iR 5055 / iR5075 / iR5075N / iR5065N / iR5055N

KEY is in common among the models that have the new iR controller, and is registered under "iRXXXX" on the SST.



KEY has 2 types (XXxc and XXxp). Be sure to download both types.

### 18.4.5.2 Downloading Procedure

iR5065 / iR 5055 / iR5075 / iR5075N / iR5065N / iR5055N

You can execute a download session in either normal or safe mode.

- 1) Select the version of KEY you want to download.

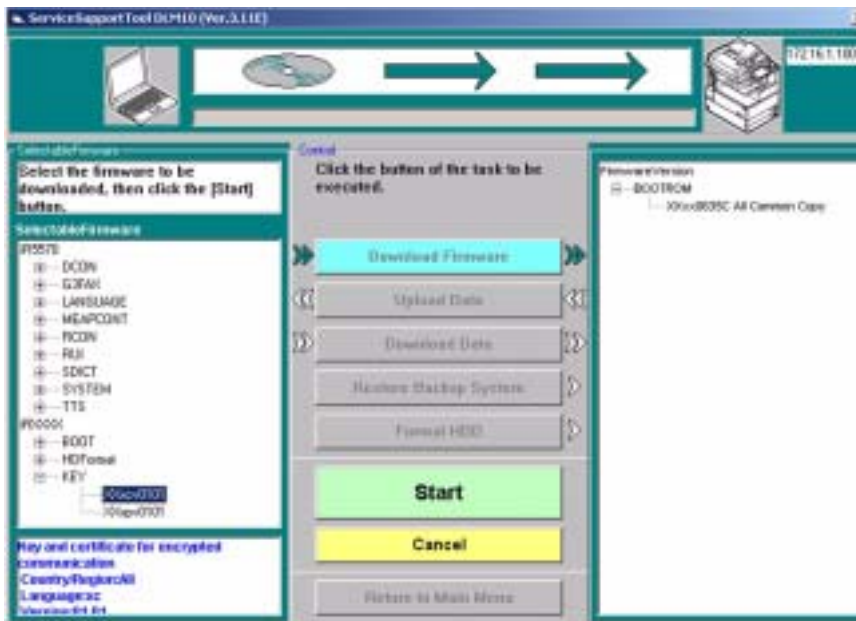

F-18-35

- 2) Click [Start].

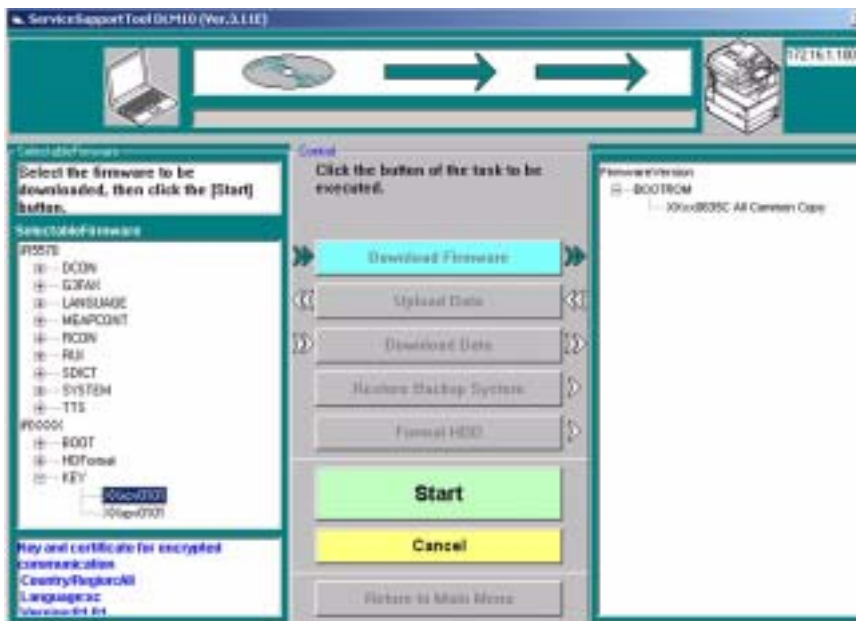

F-18-36

- 3) When the downloading session has ended, click [OK].



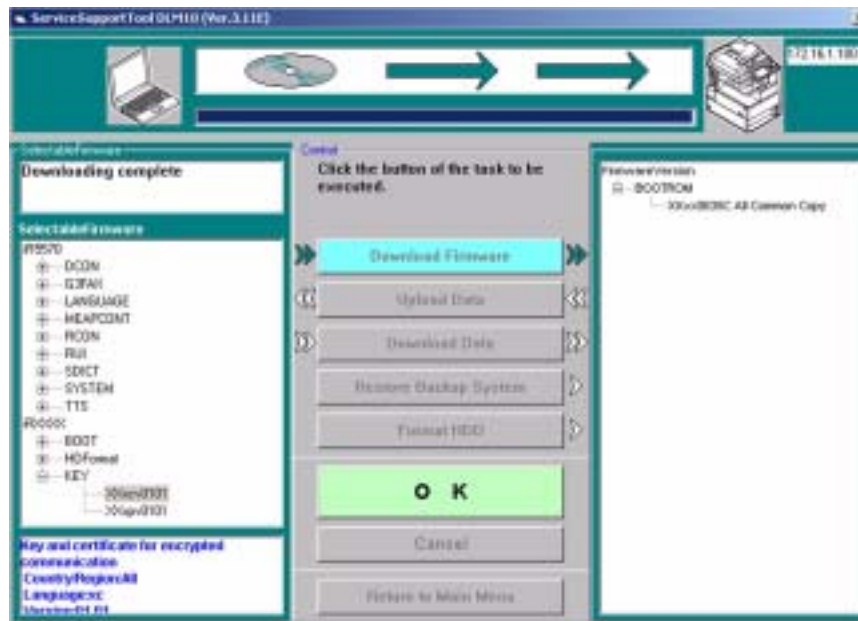

F-18-37

- 4) If you want to execute a different downloading session, see the appropriate instructions.
- 5) When you are done, turn off and then on the main power.
  - 6) See the status of upgrading indicated on the control panel of the machine. When a message appears asking you to turn off and then on the switch, turn off and then on the main power.



Be sure never to turn off the machine while it is executing a downloading session or writing downloaded system software. Otherwise, the ongoing write operation will be suspended and the machine may fail to start up. If the machine fails to start up, format BOOTDEV using HDFormat, and then download system software to be stored in the HDD such as System, Language, and RUI.

## 18.4.6 Downloading the TTS

### 18.4.6.1 Outline

iR5065 / iR 5055 / iR5075 / iR5075N / iR5065N / iR5055N

TTS is voice dictionary data when the voice guidance board is installed.

### 18.4.6.2 Downloading Procedure

iR5065 / iR 5055 / iR5075 / iR5075N / iR5065N / iR5055N

You can execute a download session in either normal or safe mode.

- 1) Select the version of TTS you want to download.

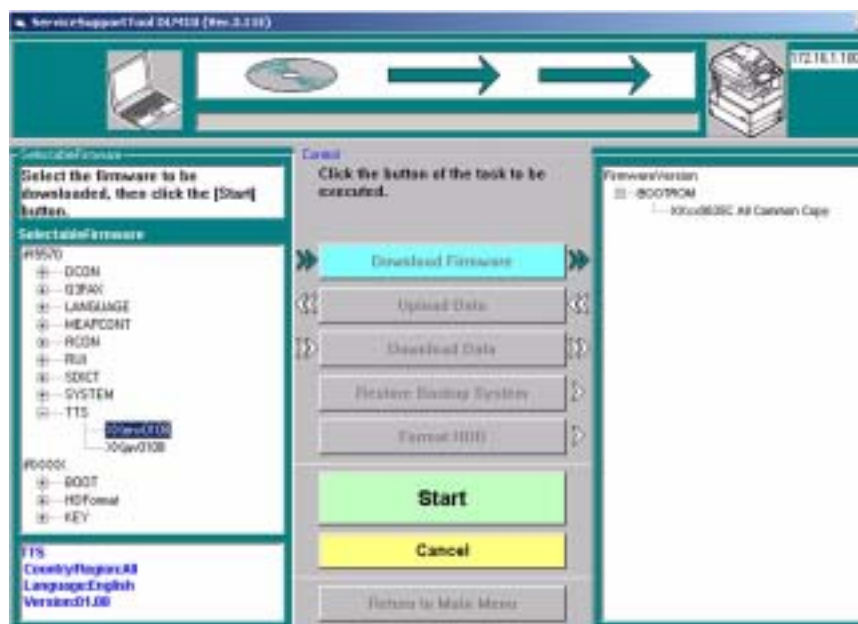

F-18-38

- 2) Click [Start].



F-18-39

3) When the downloading session has ended, click [OK].

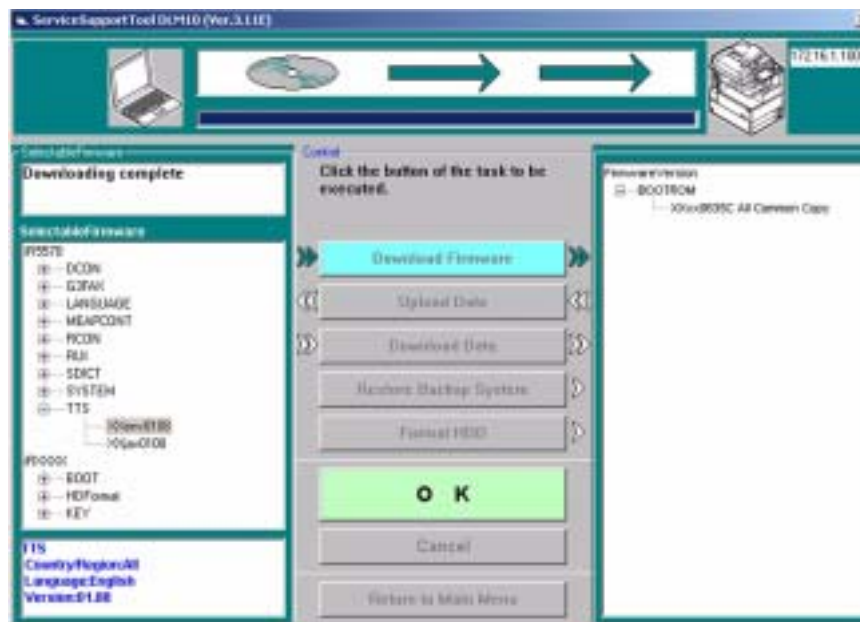

F-18-40

4) If you want to execute a different downloading session, see the appropriate instructions.

5) When you are done, turn off and then on the main power.

6) See the status of upgrading indicated on the control panel of the machine. When a message appears asking you to turn off and then on the switch, turn off and then on the main power.



Be sure never to turn off the machine while it is executing a downloading session or writing downloaded system software. Otherwise, the ongoing write operation will be suspended and the machine may fail to start up. If the machine fails to start up, format BOOTDEV using HDFORMAT, and then download system software to be stored in the HDD such as System, Language, and RUI.

## 18.4.7 Downloading BOOT

### 18.4.7.1 Outline

iR5065 / iR 5055 / iR5075 / iR5075N / iR5065N / iR5055N

Boot registered in the SST may be used in common for various types of boot ROMs. You cannot change the type of a boot ROM by means of downloading.

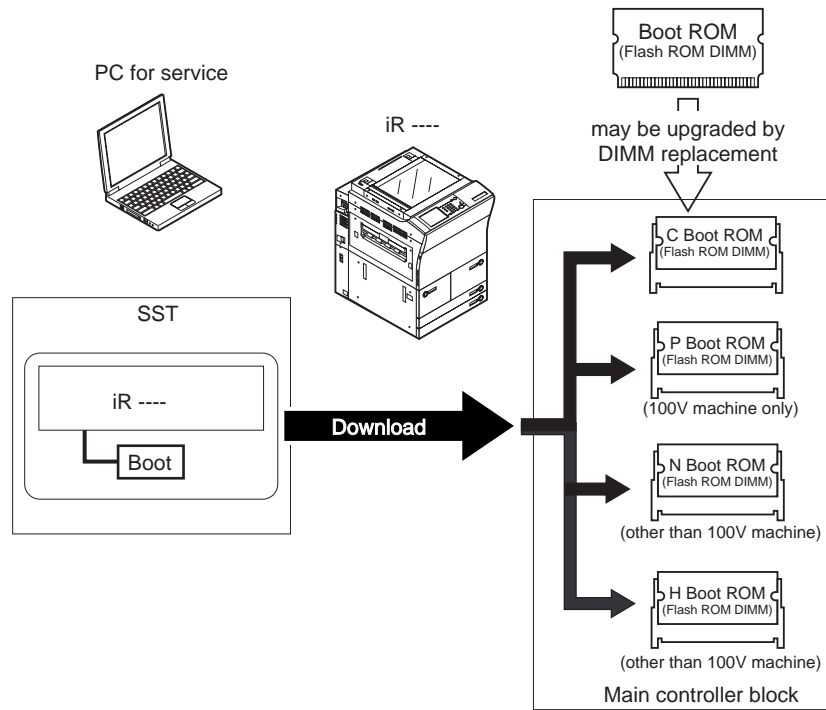

F-18-41



If a downloading session fails, you will have to replace the boot ROM.

#### 18.4.7.2 Downloading Procedure

iR5065 / iR 5055 / iR5075 / iR5075N / iR5065N / iR5055N

You can execute a downloading session in either normal or safe mode.

- 1) Select the version of BOOT to download.

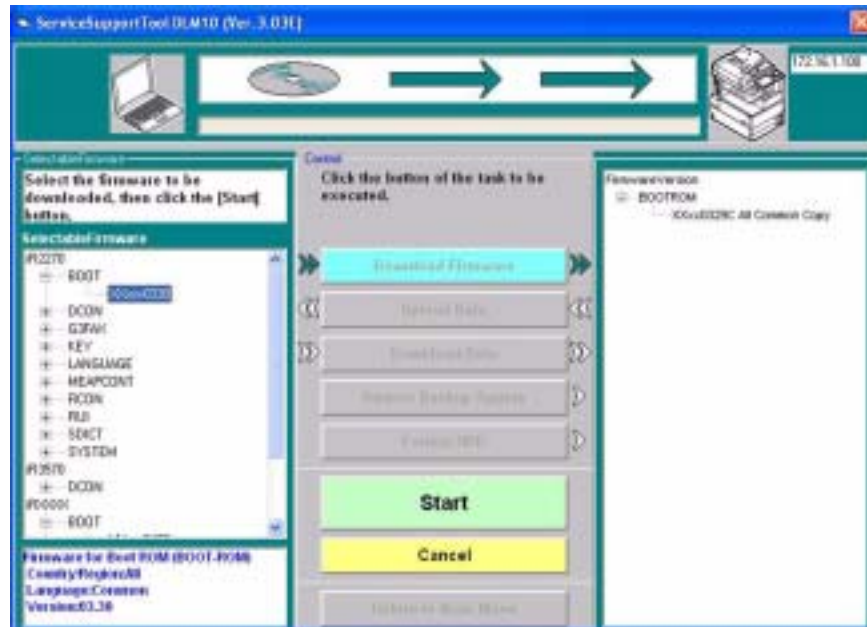

F-18-42

- 2) Click [Start].

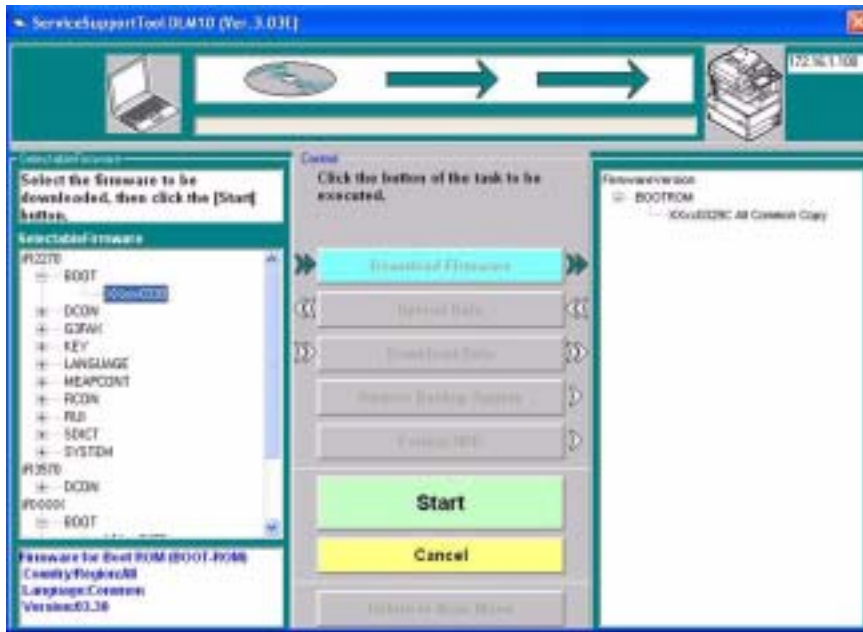

F-18-43

3) When the downloading session has ended, click [OK].



F-18-44

4) If you want to execute a different downloading session, see the appropriate instructions.

5) When you are done, turn off and then on the main power.

6) See the status of upgrading indicated on the control panel of the machine. When a message appears asking you to turn off and then on the switch, turn off and then on the main power.



Be sure never to turn off the machine while it is executing a download session or writing downloaded system software. Otherwise, the ongoing write operation will be suspended and the machine may not start up.  
If the machine fails to start up, format BOOTDEV using HDFSFormat, and then download system software to be stored in the HDD such as System, Language, and RUI.



If the machine fails to start up, be sure to replace the boot ROM.

## 18.4.8 Downloading Dcon and Rcon

### 18.4.8.1 Outline

iR5065 / iR 5055 / iR5075 / iR5075N / iR5065N / iR5055N

Dcon/Rcon is downloaded by way of the main controller unit.

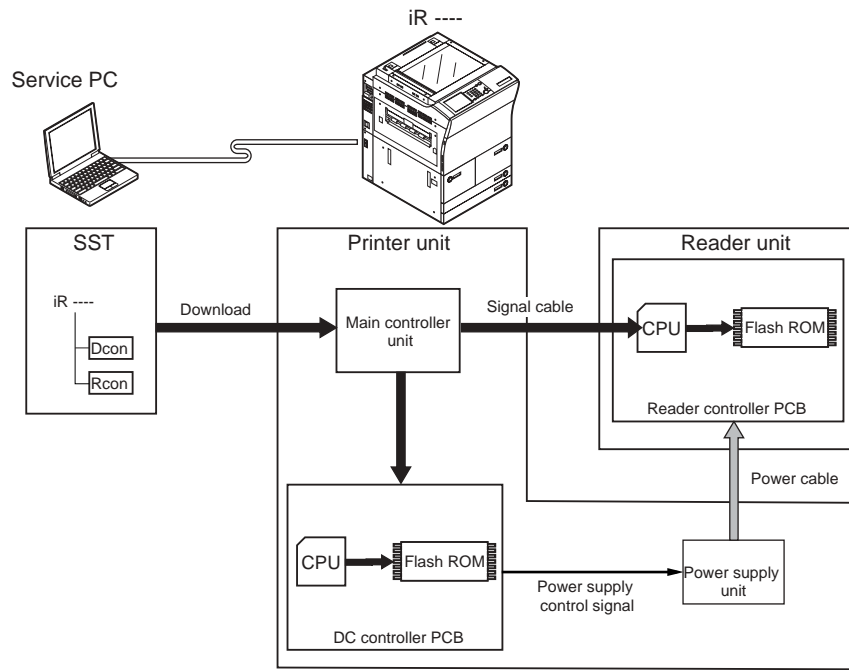

F-18-45



You will not be able to download Rcon unless the DC controller has started up normally (as, otherwise, the power supply control signal will not be valid and, as a result, the reader unit remains without power).

### 18.4.8.2 Downloading Procedure

iR5065 / iR 5055 / iR5075 / iR5075N / iR5065N / iR5055N

You can execute a downloading session in either normal or safe mode. In the case of safe mode, however, you will not be able to find out the version of Dcon/Rcon, causing all downloading to occur (overwriting of the same version and downgrading).  
[Downloading Rcon]

1) Select the version of Rcon to download.



F-18-46

2) Click [Start].



F-18-47

3) When the downloading session has ended, click [OK].



F-18-48

4) If you want to execute a different downloading session, see the appropriate instructions.

5) When the downloading session has ended, turn off and then on the machine.

6) See the status of upgrading indicated on the control panel of the machine. When a message appears asking you to turn off and then on the machine, turn off and then on the main power.



Be sure never to turn off the machine while it is executing a downloading session or writing downloaded system software. Otherwise, the machine may not be able to start up.  
If the machine fails to start up, format BOOTDEV using HDFORMAT, and then download system software to be stored in the HDD such as System, Language, and RUI.

### 18.4.9 Downloading G3 FAX

#### 18.4.9.1 Outline

iR5065 / iR 5055 / iR5075 / iR5075N / iR5065N / iR5055N

The Multi Fax Board-D1 (2-line) comes with a control CPU and its system software, which is downloaded by way of the main controller unit.

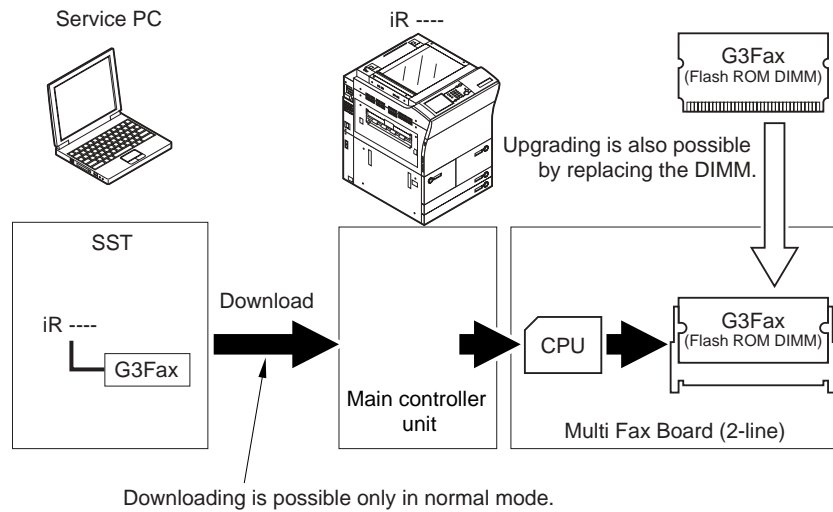

F-18-49



If a downloading session fails, you will have to replace the flash ROM DIMM.

### 18.4.9.2 Downloading Procedure

iR5065 / iR 5055 / iR5075 / iR5075N / iR5065N / iR5055N

You will have to use normal mode for downloading.

- 1) Select the version of G3FAX you want to download.

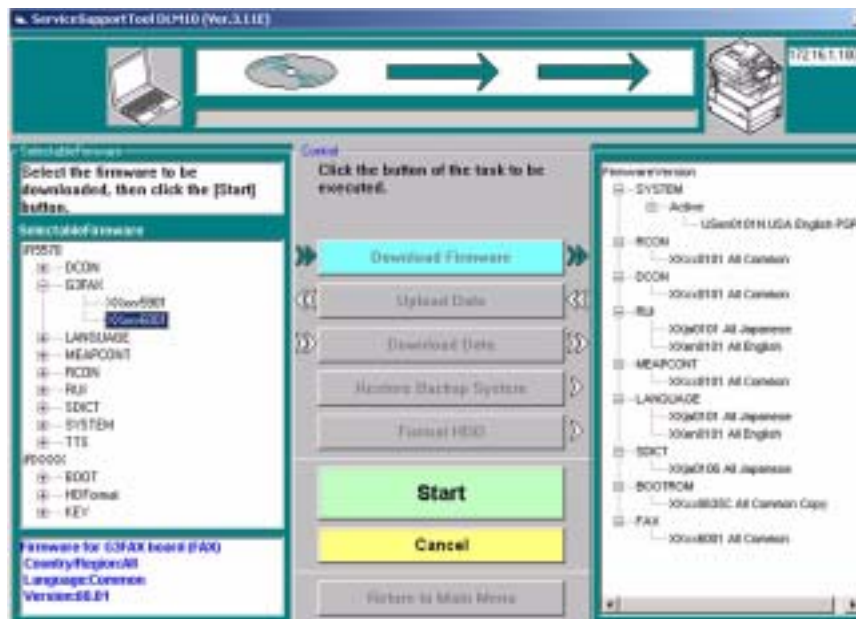

F-18-50

- 2) Click [Start].

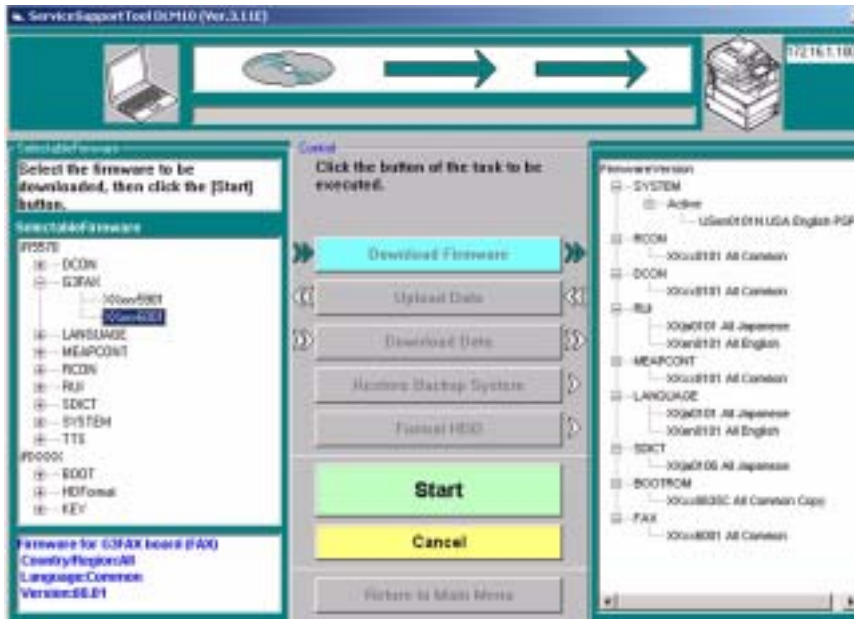

F-18-51

3) When the downloading session has ended, click [OK].

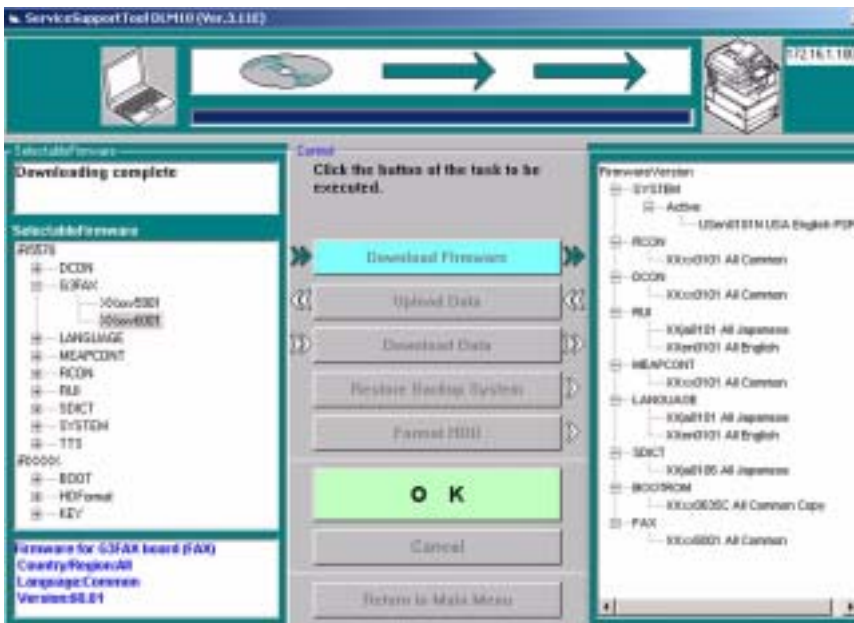

F-18-52

4) When you are done, turn off and then on the main power of the machine.

5) See the status of upgrading indicated on the control panel of the machine. When a message appears asking you to turn off and then on the machine, turn off and then on the main power.



You will not be able to download G3Fax twice in succession. (Once downloading is executed, the board will be reset, causing download mode to end.) Be sure never to turn off the machine while it is executing a downloading session or writing downloaded system software. Otherwise, the write operation (to the flash ROM DIMM of the G3 fax board) may fail, preventing board functions. In the event the board fails to function, be sure to replace the flash ROM DIMM found on the G3 fax board.

### 18.4.10 Uploading and Downloading Backup Data

#### 18.4.10.1 Outline

iR5065 / iR 5055 / iR5075 / iR5075N / iR5065N / iR5055N

SramImg is data that is stored in the SRAM of the main controller PCB, while MeapBack is a MEAP application and its data stored on the HDD.

T-18-5

Backup data	Files to select for downloading/uploading
Main controller PCB backup RAM	SramImg.bin



Backup data	Files to select for downloading/uploading
MEAP application	MeapBack.bin
for R&D	Sublog.txt



- If you are replacing the main controller PCB, you can transfer such data as parts counter readings by uploading the data before replacement and downloading it after replacement.
- If you are replacing the HDD or executing 'ALL' or 'APL\_MEP', you can temporarily set aside MEAP applications by uploading MeapBack before execution and downloading it after execution.
- Only the machine uploaded can download SramImg and MeapBack.

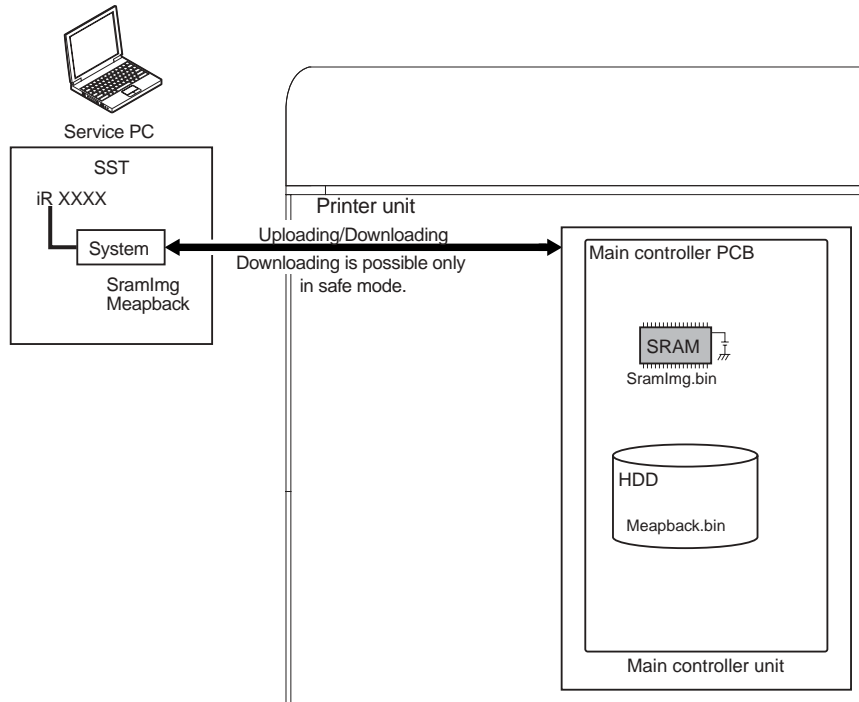

F-18-53

### 18.4.10.2 Uploading Procedure

iR5065 / iR 5055 / iR5075 / iR5075N / iR5065N / iR5055N

Use safe mode for uploading.

- 1) Select [Upload Data].

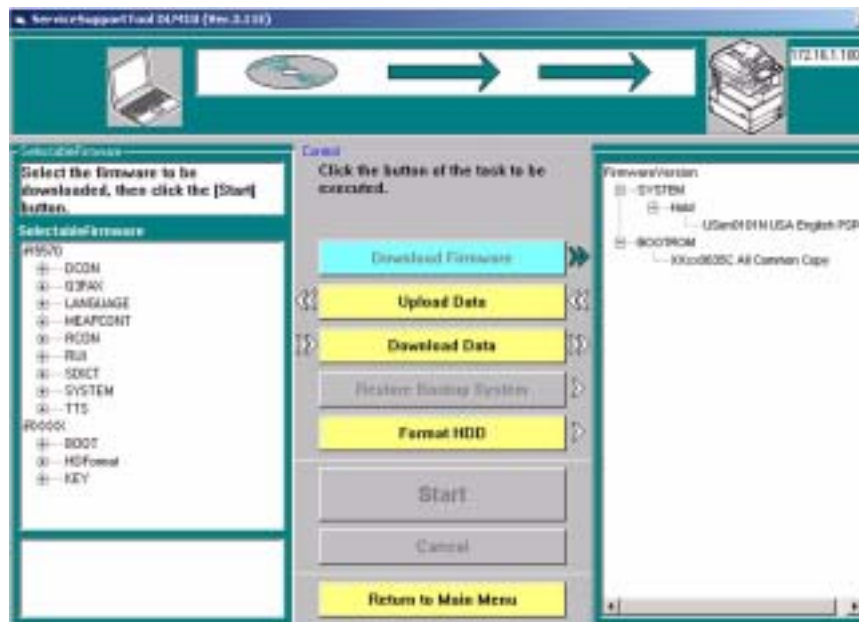

F-18-54

2) Select the data you want to back up.

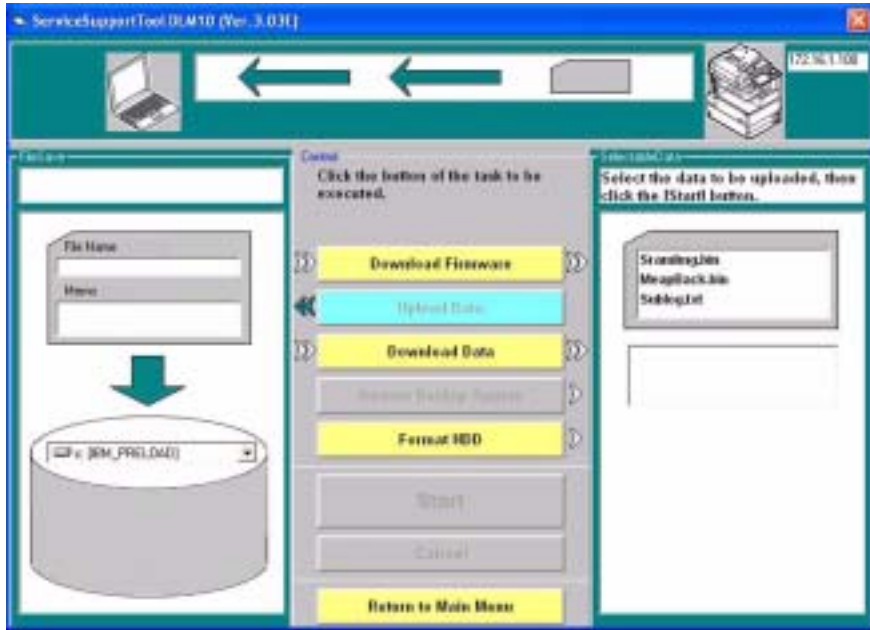

F-18-55

3) Click [Start].

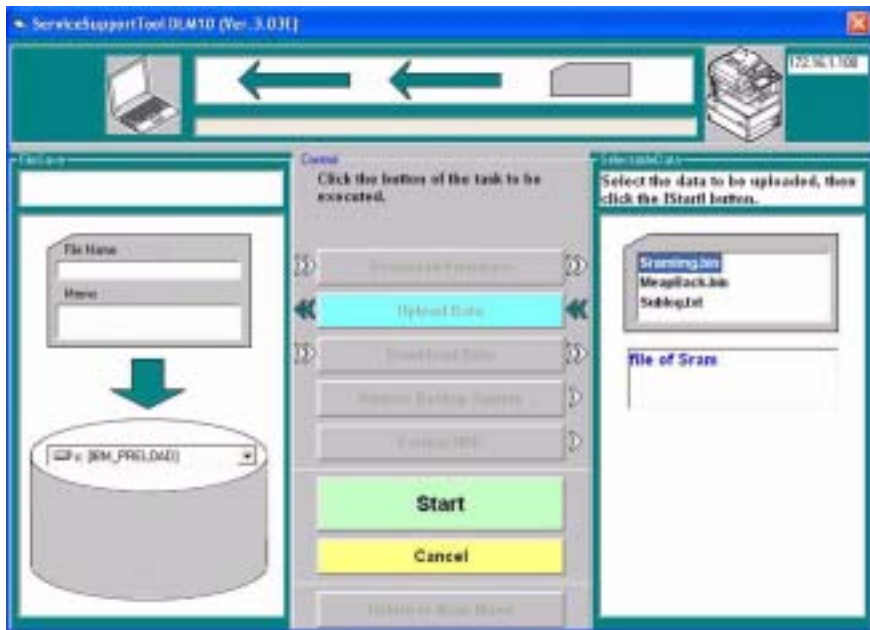

F-18-56

4) Enter a name of the file to be saved, and fill out a memo as needed. Then, click the save button.

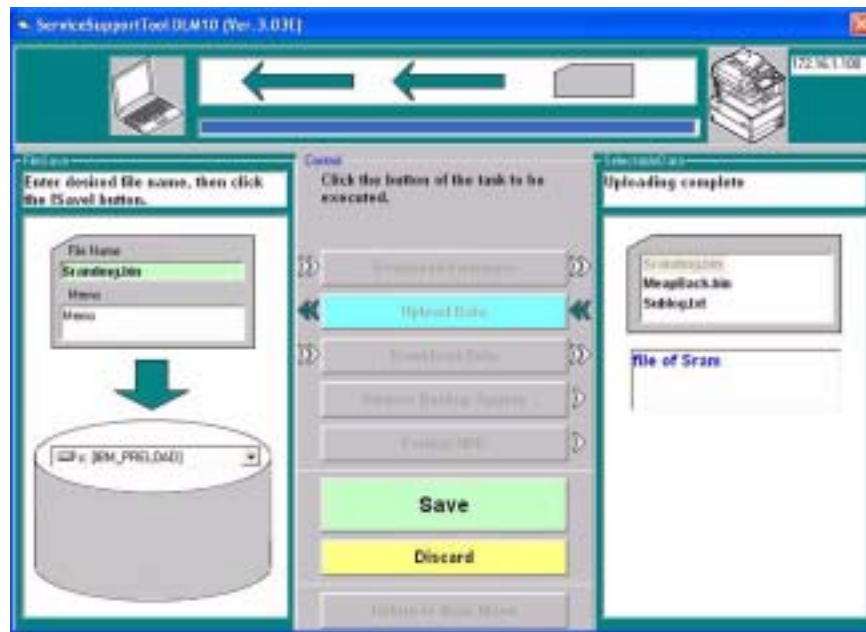

F-18-57

5) Click [OK].

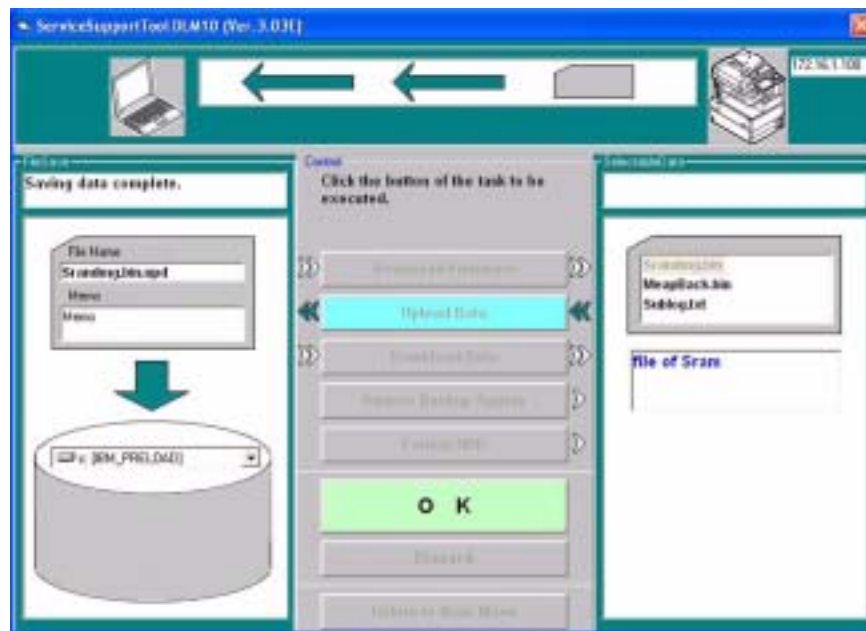

F-18-58

### 18.4.10.3 Downloading Procedure

iR5065 / iR 5055 / iR5075 / iR5075N / iR5065N / iR5055N

Use safe mode for downloading.

- 1) Select [Download Data].

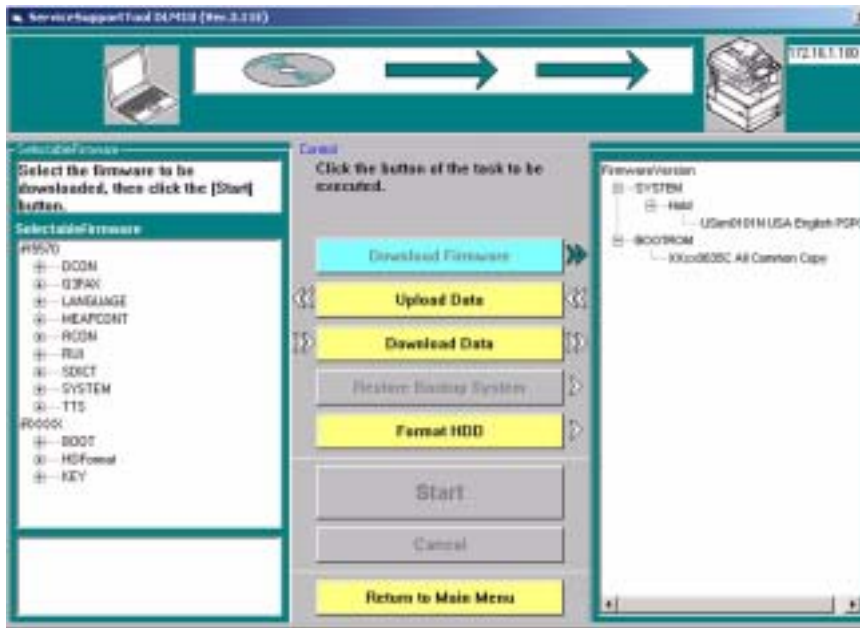

F-18-59

2) Select the data to download.

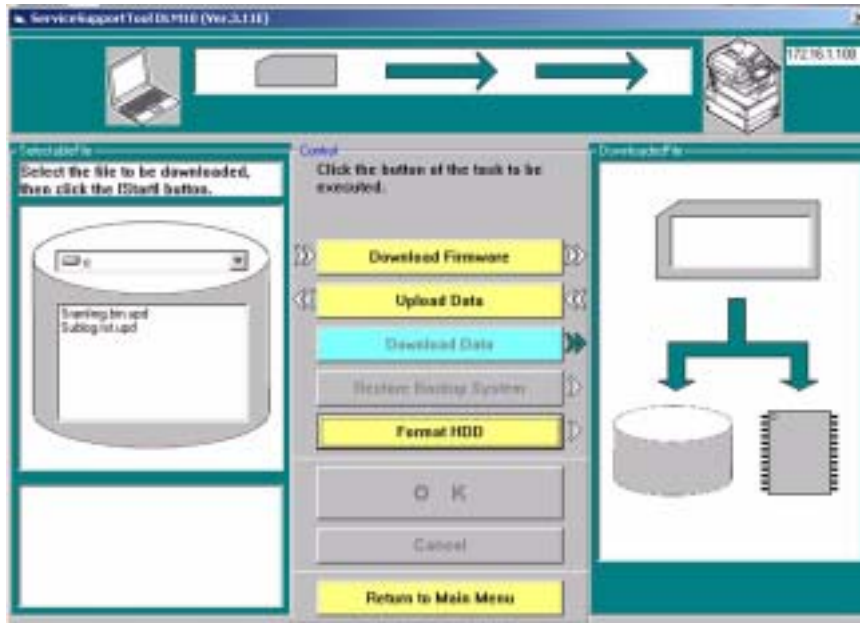

F-18-60

3) Click [Start].

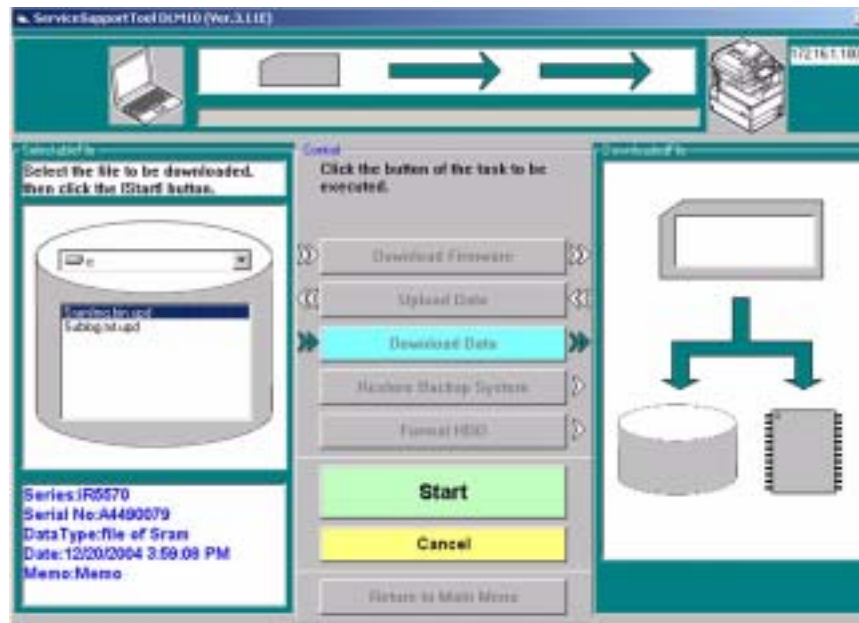

F-18-61

4) Click [OK].

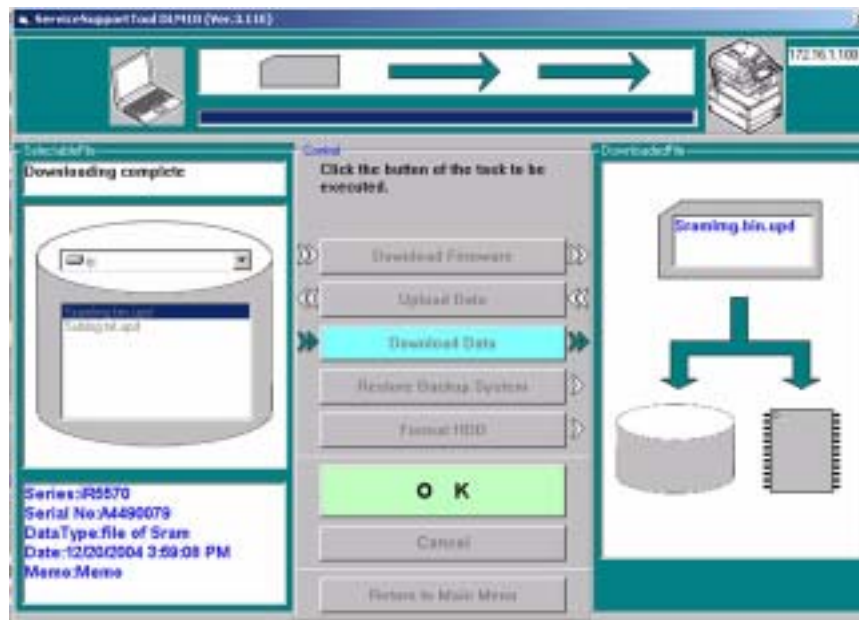

F-18-62

5) When you are done with downloading, turn off and then on the main power.

6) See the status of upgrading indicated on the control panel of the machine. When a message appears asking you to turn off and then on the switch, turn off and then on the main power.



Be sure not to turn off the machine while it is executing a downloading session or writing downloaded system software. The write operation will be suspended, and the machine may fail to start up.  
If the machine fails to start up, format BOOTDEV using HDFSFormat, and then download system software to be stored in the HDD such as System, Language, and RUI.



---

## Chapter 19 Service Tools

---





# Contents

19.1 Service Tools.....	19-1
19.1.1 List of Special Tools .....	19-1
19.1.2 List of Solvents/Oils .....	19-2



## 19.1 Service Tools

### 19.1.1 List of Special Tools

iR5065 / iR 5055 / iR5075 / iR5075N / iR5065N / iR5055N

The following special tools will be needed in addition to the standard tools set:

T-19-1

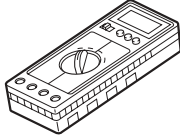
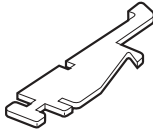
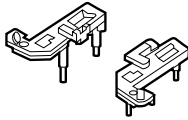
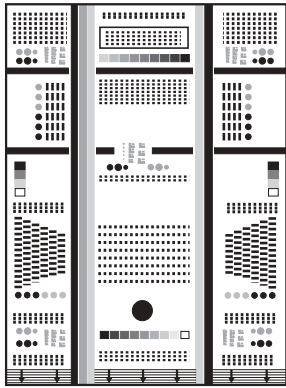
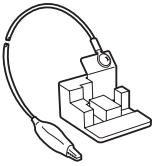
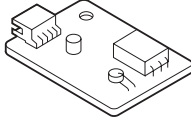
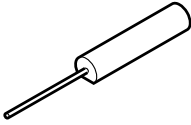
No.	Name	Toll No.	Shape	Rank	Remarks
1	Digital multimeter	FY9-2002		A	Used when making electrical checks.
2	Door switch	TKN-0093		A	
3	Mirror positioning tool (front, rear)	FY9-3009		B	Used when positioning the No. 1/No. 2 mirror.
4	NA-3 Test Sheet	FY9-9196		A	Used when adjusting/checking images.
5	Potential sensor electrode	FY9-3012		B	Used to make zero-level checks on potential sensors.
6	Environment sensor checking sensor	FY9-3014		B	Used to check the environment sensor.
7	Tester extension pin	FY9-3038		A	Used when making electrical checks.

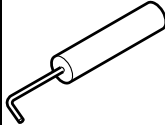
No.	Name	Toll No.	Shape	Rank	Remarks
8	Tester extension pin (L-shaped)	FY9-3039		A	Used when making electrical checks.

T-19-2

Rank:

A: each service person is expected to carry one.

B: each group of five persons is expected to carry one.

C: each workshop is expected to carry one.

### 19.1.2 List of Solvents/Oils

iR5065 / iR 5055 / iR5075 / iR5075N / iR5065N / iR5055N

T-19-3

No.	Name	Uses	Composition	Remarks
1	Alcohol	Cleaning: e.g., glass, plastic, rubber parts; external covers.	Fluoride family hydrocarbon, alcohol, surface activating agent, water	- Do not bring near fire. - Procure locally. - Substitute: IPA (isopropyl alcohol)
2	Solvent	Cleaning: metal part; oil, toner.	fluoride family hydrocarbon, chlorine family hydrocarbon, alcohol.	- Do not bring near fire. - Procure locally.
3	Heat resisting grease	Lubrication: fixing drive parts	Mineral family lithium soap, molybdenum disulfide,	Tool No.: CK-0427 (500 g/can)
4	Lubricant		Mineral oil (paraffin family)	Tool No.: CK-0524 (100 cc)
5	Lubricant	Lubrication: drive parts, friction parts	Silicone oil	Tool No.: CK-0551 (20 g)
6	Drum cleaning powder	Cleaning: photosensitive drum	Cerium oxide	Tool No.: CK-0429
7	Lubricant	Lubrication: scanner rail	Silicone oil	Tool No.: FY9-6011 (50 cc)
8	Conducting grease	Lubrication: drum heater contact	Ether, polytetra fluoroethylene	Tool No.: FY9-6008 (10 g)

Feb 29 2008

**Canon**