

Model Z-C2
Machine Codes: D191/D193
Field Service Manual

November 2013

Important Safety Notices

Responsibilities of the Customer Engineer

Customer Engineer

Maintenance shall be done only by trained customer engineers who have completed service training for the machine and all optional devices designed for use with the machine.

Reference Material for Maintenance

- Maintenance shall be done using the special tools and procedures prescribed for maintenance of the machine described in the reference materials (service manuals, technical bulletins, operating instructions, and safety guidelines for customer engineers).
- In regard to other safety issues not described in this document, all customer engineers shall strictly obey procedures and recommendations described the "CE Safety Guide".
- Use only consumable supplies and replacement parts designed for use of the machine.

Before Installation, Maintenance

Shipping and Moving the Machine

CAUTION

- Work carefully when lifting or moving the machine. If the machine is heavy, two or more customer engineers may be required to prevent injuries (muscle strains, spinal injuries, etc.) or damage to the machine if it is dropped or tipped over.
- Personnel moving or working around the machine should always wear proper clothing and footwear. Never wear loose fitting clothing or accessories (neckties, loose sweaters, bracelets, etc.) or casual footwear (slippers, sandals, etc.) when lifting or moving the machine.
- Always unplug the power cord from the power source before you move the product. Before you move the product, arrange the power cord so it will not fall under the product.

Power

WARNING

- Always disconnect the power plug before doing any maintenance procedure. After switching off the machine, power is still supplied to the main machine and other devices. To prevent electrical

shock, switch the machine off, wait for a few seconds, then unplug the machine from the power source.

- Before you do any checks or adjustments after turning the machine off, work carefully to avoid injury. After removing covers or opening the machine to do checks or adjustments, never touch electrical components or moving parts (gears, timing belts, etc.).
- After turning the machine on with any cover removed, keep your hands away from electrical components and moving parts. Never touch the cover of the fusing unit, gears, timing belts, etc.

Installation, Disassembly, and Adjustments

CAUTION

- After installation, maintenance, or adjustment, always check the operation of the machine to make sure that it is operating normally. This ensures that all shipping materials, protective materials, wires and tags, metal brackets, etc., removed for installation, have been removed and that no tools remain inside the machine. This also ensures that all release interlock switches have been restored to normal operation.
- Never use your fingers to check moving parts causing spurious noise. Never use your fingers to lubricate moving parts while the machine is operating.

Special Tools

CAUTION

- Use only standard tools approved for machine maintenance.
- For special adjustments, use only the special tools and lubricants described in the service manual. Using tools incorrectly, or using tools that could damage parts, could damage the machine or cause injuries.

During Maintenance

General

CAUTION

- Before you begin a maintenance procedure: 1) Switch the machine off, 2) Disconnect the power plug from the power source, 3) Allow the machine to cool for at least 10 minutes.
- Avoid touching the components inside the machine that are labeled as hot surfaces.

Safety Devices

WARNING

- Never remove any safety device unless it requires replacement. Always replace safety devices immediately.
- Never do any procedure that defeats the function of any safety device. Modification or removal of a safety device (fuse, switch, etc.) could lead to a fire and personal injury. Always test the operation of the machine to ensure that it is operating normally and safely after removal and replacement of any safety device.
- For replacements use only the correct fuses or circuit breakers rated for use with the machine. Using replacement devices not designed for use with the machine could lead to a fire and personal injuries.

Organic Cleaners

CAUTION

- During preventive maintenance, never use any organic cleaners (alcohol, etc.) other than those described in the service manual.
- Make sure the room is well ventilated before using any organic cleaner. Use organic solvents in small amounts to avoid breathing the fumes and becoming nauseous.
- Switch the machine off, unplug it, and allow it to cool before doing preventive maintenance. To avoid fire or explosion, never use an organic cleaner near any part that generates heat.
- Wash your hands thoroughly after cleaning parts with an organic cleaner to contamination of food, drinks, etc. which could cause illness.
- Clean the floor completely after accidental spillage of silicone oil or other materials to prevent slippery surfaces that could cause accidents leading to hand or leg injuries. Use "My Ace" Silicone Oil Remover (or dry rags) to soak up spills. For more details, please refer to Technical Bulletin "Silicone Oil Removal" (A024-50).

Lithium Batteries

WARNING

- Always replace a lithium battery on a PCB with the same type of battery prescribed for use on that board. Replacing a lithium battery with any type other than the one prescribed for use on the board could lead to an explosion or damage to the PCB.
- Never discard used batteries by mixing them with other trash. Remove them from the work site and dispose of them in accordance with local laws and regulations regarding the disposal of such items.

Power Plug and Power Cord

WARNING

- Before serving the machine (especially when responding to a service call), always make sure that the power plug has been inserted completely into the power source. A partially inserted plug could lead to heat generation (due to a power surge caused by high resistance) and cause a fire or other problems.
- Always check the power plug and make sure that it is free of dust and lint. Clean it if necessary. A dirty plug can generate heat which could cause a fire.
- Inspect the length of the power cord for cuts or other damage. Replace the power cord if necessary. A frayed or otherwise damaged power cord can cause a short circuit which could lead to a fire or personal injury from electrical shock.
- Check the length of the power cord between the machine and power supply. Make sure the power cord is not coiled or wrapped around any object such as a table leg. Coiling the power cord can cause excessive heat to build up and could cause a fire.
- Make sure that the area around the power source is free of obstacles so the power cord can be removed quickly in case of an emergency.
- Make sure that the power cord is grounded (earthed) at the power source with the ground wire on the plug.
- Connect the power cord directly into the power source. Never use an extension cord.
- When you disconnect the power plug from the power source, always pull on the plug, not the cable.

After Installation, Servicing

Disposal of Used Items

WARNING

- Never incinerate used toner or toner cartridges.
- Toner or toner cartridges thrown into a fire can ignite or explode and cause serious injury. At the work site always carefully wrap used toner and toner cartridges with plastic bags to avoid spillage before disposal or removal.

CAUTION

- Always dispose of used items (developer, toner, toner cartridges, OPC drums, etc.) in accordance with the local laws and regulations regarding the disposal of such items.

-
- To protect the environment, never dispose of this product or any kind of waste from consumables at a household waste collection point. Dispose of these items at one of our dealers or at an authorized collection site.
 - Return used selenium drums to the service center for handling in accordance with company policy regarding the recycling or disposal of such items.

Points to Confirm with Operators

At the end of installation or a service call, instruct the user about use of the machine. Emphasize the following points.

- Show operators how to remove jammed paper and troubleshoot other minor problems by following the procedures described in the operating instructions.
- Point out the parts inside the machine that they should never touch or attempt to remove.
- Confirm that operators know how to store and dispose of consumables.
- Make sure that all operators have access to an operating instruction manual for the machine.
- Confirm that operators have read and understand all the safety instructions described in the operating instructions.
- Demonstrate how to turn off the power and disconnect the power plug (by pulling the plug, not the cord) if any of the following events occur: 1) something has spilled into the product, 2) service or repair of the product is necessary, 3) the product cover has been damaged.
- Caution operators about removing paper fasteners around the machine. They should never allow paper clips, staples, or any other small metallic objects to fall into the machine.

Special Safety Instructions for Toner

Accidental Physical Exposure

CAUTION

- Work carefully when removing paper jams or replacing toner bottles or cartridges to avoid spilling toner on clothing or the hands.
- If toner is inhaled, immediately gargle with large amounts of cold water and move to a well ventilated location. If there are signs of irritation or other problems, seek medical attention.
- If toner gets on the skin, wash immediately with soap and cold running water.
- If toner gets into the eyes, flush the eyes with cold running water or eye wash. If there are signs of irritation or other problems, seek medical attention.
- If toner is swallowed, drink a large amount of cold water to dilute the ingested toner. If there are signs of any problem, seek medical attention.

-
- If toner spills on clothing, wash the affected area immediately with soap and cold water. Never use hot water! Hot water can cause toner to set and permanently stain fabric.

Handling and Storing Toner

WARNING

- Toner, used toner, and developer are extremely flammable.
- Never store toner, developer, toner cartridges, or toner bottles (including empty toner bottles or cartridges) in a location where they will be exposed to high temperature or an open flame.

CAUTION

- Always store toner and developer supplies such as toner and developer packages, cartridges, and bottles (including used toner and empty bottles and cartridges) out of the reach of children.
- Always store fresh toner supplies or empty bottles or cartridges in a cool, dry location that is not exposed to direct sunlight.

Toner Disposal

WARNING

- Never attempt to incinerate toner, used toner, or empty toner containers (bottles or cartridges). Burning toner can explode and scatter, causing serious burns.
- Always wrap used toner and empty toner bottles and cartridges in plastic bags to avoid spillage. Follow the local laws and regulations regarding the disposal of such items.
- Dispose of used toner and toner cartridges at one of our dealers or at an authorized collection site. Always dispose of used toner cartridges and toner bottles in accordance with the local laws and regulations regarding the disposal of such items.

Safety Instructions for this Machine

Prevention of Physical Injury

1. Before disassembling or assembling parts of the machine and peripherals, make sure that the machine and peripheral power cords are unplugged.
2. The plug should be near the machine and easily accessible.
3. Note that some components of the machine and the paper tray unit are supplied with electrical voltage even if the main power switch is turned off.
4. If any adjustment or operation check has to be made with exterior covers off or open while the main switch is turned on, keep hands away from electrified or mechanically driven components.

-
5. If the [Start] key is pressed before the machine completes the warm-up period (the [Start] key starts blinking red and green), keep hands away from the mechanical and the electrical components as the machine starts making copies as soon as the warm-up period is completed.
 6. The inside and the metal parts of the fusing unit become extremely hot while the machine is operating. Be careful to avoid touching those components with your bare hands.
 7. To prevent a fire or explosion, keep the machine away from flammable liquids, gases, and aerosols.
 8. When a thick book or three-dimensional original is placed on the exposure glass and the ARDF cover is lowered, the back side of the ARDF rises up to accommodate the original. Therefore, when closing the ARDF, please be sure to keep your hands away from the hinges at the back of the ARDF.

Health Safety Conditions

1. Never operate the machine without the ozone filters installed.
2. Always replace the ozone filters with the specified types at the proper intervals.
3. Toner and developer are non-toxic, but if you get either of them in your eyes by accident, it may cause temporary eye discomfort. Try to remove with eye drops or flush with water as first aid. If unsuccessful, get medical attention.

Observance of Electrical Safety Standards

1. The machine and its peripherals must be installed and maintained by a customer service representative who has completed the training course on those models.
2. The NVRAM on the system control board has a lithium battery which can explode if replaced incorrectly. Replace the NVRAM only with an identical one. The manufacturer recommends replacing the entire NVRAM. Do not recharge or burn this battery. Used NVRAM must be handled in accordance with local regulations.

Safety and Ecological Notes for Disposal

1. Do not incinerate toner bottles or used toner. Toner dust may ignite suddenly when exposed to an open flame.
2. Dispose of used toner, developer, and organic photoconductors in accordance with local regulations. (These are non-toxic supplies.)
3. Dispose of replaced parts in accordance with local regulations.
4. When keeping used lithium batteries in order to dispose of them later, do not put more than 100 batteries per sealed box. Storing larger numbers or not sealing them apart may lead to chemical reactions and heat build-up.

⚠ CAUTION

- The danger of explosion exists if a battery of this type is incorrectly replaced.
- Replace only with the same or an equivalent type recommended by the manufacturer. Discard used batteries in accordance with the manufacturer's instructions.

Laser Safety

The Center for Devices and Radiological Health (CDRH) prohibits the repair of laser-based optical units in the field. The optical housing unit can only be repaired in a factory or at a location with the requisite equipment. The laser subsystem is replaceable in the field by a qualified Customer Engineer. The laser chassis is not repairable in the field. Customer engineers are therefore directed to return all chassis and laser subsystems to the factory or service depot when replacement of the optical subsystem is required.

⚠ WARNING

- Use of controls, or adjustment, or performance of procedures other than those specified in this manual may result in hazardous radiation exposure.

⚠ WARNING







- **WARNING:** Turn off the main switch before attempting any of the procedures in the Laser Optics Housing Unit section. Laser beams can seriously damage your eyes.
- **CAUTION MARKING:**



m022i500

Symbols, Abbreviations and Trademarks

This manual uses several symbols and abbreviations. The meaning of those symbols and abbreviations are as follows:

	See or Refer to
	Clip ring
	Screw
	Connector
	Clamp
	E-ring
SEF	Short Edge Feed
LEF	Long Edge Feed

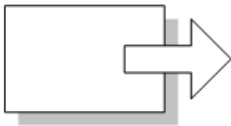

Short Edge Feed (SEF)

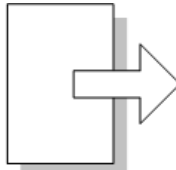

Long Edge Feed (LEF)

m022v701

Trademarks

Adobe, Acrobat, PostScript, PostScript 3, and Reader are either registered trademarks or trademarks of Adobe Systems Incorporated in the United States and/or other countries.

The Bluetooth® word mark and logos are registered trademarks owned by Bluetooth SIG, Inc. and any use of such marks by Ricoh Company, Ltd. is under license.

Microsoft and Windows are either registered trademarks or trademarks of Microsoft Corp. in the United States and/or other countries.

The SD and SD logo are trademarks of SD-3C, LLC.

Other product names used herein are for identification purposes only and might be trademarks of their respective companies. We disclaim any and all rights to those marks.

Microsoft product screen shots reprinted with permission from Microsoft Corporation.

TABLE OF CONTENTS

Important Safety Notices.....	1
Responsibilities of the Customer Engineer.....	1
Customer Engineer.....	1
Reference Material for Maintenance.....	1
Before Installation, Maintenance.....	1
Shipping and Moving the Machine.....	1
Power.....	1
Installation, Disassembly, and Adjustments.....	2
Special Tools.....	2
During Maintenance.....	2
General.....	2
Safety Devices.....	3
Organic Cleaners.....	3
Lithium Batteries.....	3
Power Plug and Power Cord.....	4
After Installation, Servicing.....	4
Disposal of Used Items.....	4
Points to Confirm with Operators.....	5
Special Safety Instructions for Toner.....	5
Accidental Physical Exposure.....	5
Handling and Storing Toner.....	6
Toner Disposal.....	6
Safety Instructions for this Machine.....	6
Prevention of Physical Injury.....	6
Health Safety Conditions.....	7
Observance of Electrical Safety Standards.....	7
Safety and Ecological Notes for Disposal.....	7
Laser Safety.....	8
Symbols, Abbreviations and Trademarks.....	9
Trademarks.....	9
1. Product Information	
Specifications.....	31
Guidance for Those Familiar with Predecessor Products.....	32

Basic Machine Configuration.....	32
New General Features.....	32
Options.....	33
Machine Options.....	33
Controller Options.....	33
Fax Options.....	34
Other.....	34
Machine Exterior.....	35
Decal.....	35
Operation Panel.....	35
Right Rear Corner Cover.....	36
Controller Board Faceplate Layout.....	37
SD Card Storage Location.....	38
Main Power Switch.....	38
ADF.....	40
Boards.....	42
IPU (Rear).....	42
Scanner Unit IDB.....	43
Controller Board.....	43
Controller Fan.....	44
SDB Eliminated.....	45
HDD Unit (Standard).....	45
HDD Unit (Option).....	46
External Appearance.....	47
Machine Configuration.....	48
Machine Configuration.....	48
Main machine.....	48
Options.....	48
Overview.....	50
Component Layout.....	50
Paper Path.....	51
Standard model (Basic).....	51
Standard model (Full option).....	52

Finisher model (Basic).....	53
Finisher model (Full option).....	54
Drive Layout.....	55
2. Installation	
Installation Requirements.....	57
Environment.....	57
Machine Level.....	58
Machine Space Requirements.....	58
Machine Dimensions.....	59
Power Requirements.....	59
Optional Unit Combinations.....	61
Machine Options.....	61
Controller Options.....	62
Fax Options.....	62
Other Options.....	62
Copier Installation.....	64
Installation Flow Chart.....	64
Basic model.....	64
Finisher model.....	64
Accessory Check.....	65
Installation Procedure.....	66
Tapes, Retainers and Toner Bottles.....	67
Paper Tray.....	75
Decals.....	75
Left Tray Setting for D193.....	76
Initialize the Developer.....	76
Settings Relevant to the Service Contract.....	77
Settings for @Remote Service.....	78
Security Function Installation.....	81
Data Overwrite Security.....	82
HDD Encryption.....	84
When the data overwrite security and encryption functions cause a problem.....	90
Moving the Machine.....	93

Transporting the Machine.....	93
Main Frame.....	93
Paper Feed Unit (M368).....	94
Component Check.....	94
Installation Procedure.....	94
For installing the paper feed unit (M368) only.....	95
For installing with the paper feed unit (M367).....	97
Paper Feed Unit (M367).....	103
Component Check.....	103
Installation Procedure.....	103
For installing the paper feed unit (M367) only.....	104
For installing with the paper feed unit (M368).....	106
Side Tray (M369).....	111
Component Check.....	111
Installation Procedure.....	111
1-Bin Tray Unit (M370).....	116
Component Check.....	116
Installation Procedure.....	116
Enhanced Security HDD Option Type M10 (D792-09).....	123
Accessory Check.....	123
Installation.....	123
After Installing the HDD.....	129
Optional Counter Interface Unit (B870).....	132
Installation Procedure.....	132
Copy Data Security Unit (D640).....	134
Accessories.....	134
Installation.....	134
User Tool Setting.....	135
Tray Heater (Mainframe).....	136
Installation Procedure.....	136
Tray Heater (Optional Unit).....	137
Component Check.....	137
Installation Procedure.....	137

For Installing the Tray Heater in M367.....	138
For Installing the Tray Heater in M368.....	145
Smart Operation Panel Type M10 (D190).....	150
Accessories.....	150
Before Installation.....	151
Installation.....	151
Firmware Update, Initial SP Settings.....	151
Removing Standard Operation Panel and Hinge.....	153
Smart Operation Panel Installation.....	157
Power On.....	164
Controller Options.....	166
Overview.....	166
SD Card Appli Move.....	167
Overview.....	167
Move Exec.....	168
Undo Exec.....	169
File Format Converter Type E (D377-04).....	170
Accessories.....	170
Installation.....	170
IEEE 802.11 Interface Unit Type O (M417).....	172
Accessories.....	172
Installation.....	172
Browser Unit Type M10 (D792-03, -04).....	174
Installation Procedure.....	174
Do the following steps if the customer is using the Ricoh JavaScript connected to a Web application developed by Operius/RiDP.....	175
Browser/EXJS Firmware Update Procedure.....	175
EXJS Firmware Un-install Procedure.....	177
IC Card Reader.....	178
Bluetooth Interface Unit Type D (D566).....	180
Accessories.....	180
Installation.....	181
Camera Direct Print Card Type M10 (D792-07).....	181

Installation.....	182
XPS Direct Print Option Type M10 (D792-08).....	182
Installation.....	183
SD card for NetWare printing Type M10 (D792-06).....	183
Accessories.....	183
Installation.....	184
OCR Unit Type M2 (D166-25, -26).....	184
What is Searchable PDF?.....	184
Accessories.....	185
Installation.....	185
Restoration.....	186
When the original SD card exists.....	187
If Original SD Card is Lost.....	187
DataOverwriteSecurity Unit Type H (D377-22).....	187
Overview.....	187
Component List.....	187
Installation Procedure.....	188
Check All Connections.....	188
3. Preventive Maintenance	
Maintenance Tables.....	189
PM Parts Settings.....	190
Before Removing the Old PM Parts.....	190
After installing the new PM parts.....	191
Preparation before operation check.....	191
Operation check.....	192
4. Replacement and Adjustment	
Notes on the Main Power Switch.....	193
Push Switch.....	193
Characteristics of the Push Switch (DC Switch).....	193
Shutdown Method.....	194
Forced Shutdown.....	194
Beforehand.....	196
Special Tools.....	197

Image Adjustment.....	198
Scanning.....	198
Scanner sub-scan magnification.....	198
Scanner leading edge and side-to-side registration.....	199
ARDF.....	199
ARDF side-to-side, leading edge registration and trailing edge.....	199
ARDF sub-scan magnification.....	200
Registration.....	200
Image Area.....	200
Leading Edge.....	200
Side to Side.....	201
Adjustment Standard.....	201
Paper Registration Standard.....	201
Adjustment Procedure.....	201
Erase Margin Adjustment.....	202
Color Registration.....	202
Line Position Adjustment.....	202
Printer Gamma Correction.....	203
Copy Mode.....	203
Printer Mode.....	207
Exterior Covers.....	209
Front Door.....	209
Toner Collection Bottle.....	210
Left Cover.....	211
Rear Lower Cover.....	212
Rear Cover.....	213
Dust Filter.....	213
Exhaust Filter.....	214
Right Rear Cover.....	214
Operation Panel.....	215
LCD Board.....	217
Operation Panel Interface Board.....	219
LCD Unit.....	220

Operation Panel Main Board.....	221
Operation Panel Sub Board.....	221
Operation Panel Keys.....	222
Touch Panel Position Adjustment.....	223
Paper Exit Tray.....	224
Inner Right Cover.....	226
Basic model.....	226
Finisher model.....	228
Inner Right Lower Cover.....	229
Right Upper Cover.....	231
Scanner Unit.....	232
Exposure Glass.....	232
ARDF Exposure Glass.....	234
LED Board.....	236
Scanner Motor.....	238
Sensor Board Unit (SBU).....	239
When reassembling.....	240
IDB.....	240
Scanner HP Sensor.....	242
Cover Sensor.....	243
Front Scanner Wire.....	244
Reinstalling the Front Scanner Wire.....	246
Rear Scanner Wire.....	250
Reinstalling the Rear Scanner Wire.....	251
Laser Optics.....	253
Caution Decal Location.....	253
Laser Unit.....	253
Preparing the new laser unit.....	254
Before removing the old laser unit.....	254
Recovery procedure for no replacement preparation of laser unit.....	255
Removing the laser unit.....	255
After installing a new laser unit.....	258
Ventilation Fan.....	259

When installing the ventilation fan.....	260
Image Creation.....	261
PCDU (Photo Conductor and Development Unit).....	261
When installing a new PCDU.....	262
PCU and Development Unit.....	266
When Reinstalling the PCDU.....	269
Toner Supply Motor.....	270
Toner Collection Motor.....	271
Waste Toner Bottle Full Sensor.....	273
Waste Toner Bottle Set Sensor.....	274
RFID CPU Board.....	274
RFID Board.....	275
Toner Supply Fan.....	275
When installing the toner supply fan.....	276
Image Transfer.....	277
ITB (Image Transfer Belt) Unit.....	277
Image Transfer Belt, ITB Cleaning Unit.....	279
When Installing the Image Transfer Belt.....	285
ITB Encoder.....	286
ITB Contact Motor.....	290
ITB Contact Sensor.....	291
ID Sensor Board.....	293
After installing a new ID sensor board.....	295
Paper Transfer.....	296
PTR (Paper Transfer Roller) Unit.....	296
When Installing the PTR Unit.....	297
PTR Contact Motor.....	297
PTR Contact Sensor.....	300
Temperature and Humidity Sensor.....	301
Drive Unit.....	303
Gear Unit.....	303
Drum Motor: CMY.....	308
Development Motor: CMY.....	309

ITB Unit/ Drum: K/ Development: K Motor.....	310
Development Clutch: K.....	311
Fusing/Paper Exit Motor.....	311
Motors with Bracket.....	312
Registration Motor.....	314
Duplex/ By-pass Motor.....	314
Paper Feed Motor.....	315
Vertical Transport Motor.....	316
Drum Phase Sensor: CMY.....	318
Drum Phase Sensor: K.....	319
Inverter Motor.....	320
Drive Unit Fan.....	321
When installing the drive unit fan.....	321
Fusing.....	322
Fusing Unit Maintenance Parts.....	322
Fusing Unit.....	322
When installing the fusing unit.....	323
Cleaning Unit.....	323
Oil Supply Roller.....	324
Cleaning Roller.....	325
Plain Shaft Bearing.....	325
Pressure Roller Fusing Lamp.....	326
Pressure Roller.....	329
When Reinstalling the Pressure Roller.....	330
Heating Roller Fusing Lamp.....	331
Fusing Belt.....	336
Fusing, Heating and Tension Roller.....	338
When Reinstalling the Fusing Roller.....	338
Heating Roller Thermostat.....	339
Heating Roller Thermistor.....	340
Pressure Roller Thermistor.....	341
Pressure Roller Thermostat.....	342
Thermopile.....	342

Fusing Front Fan.....	343
When installing the fusing front fan.....	344
Fusing Rear Fan.....	344
When installing the fusing rear fan.....	346
Paper Feed.....	347
Separation Roller.....	347
Paper Feed Unit.....	347
Pick-up and Paper Feed Rollers.....	349
Registration Sensor.....	350
Vertical Transport Sensor.....	351
Paper Lift Sensor.....	352
Paper End Sensor.....	353
Paper Feed Sensor.....	354
Tray Lift Motor.....	355
Paper Size Switch.....	356
Cleaning the Paper Dust Container.....	356
Paper Exit.....	358
Paper Exit Unit.....	358
Basic model.....	358
Finisher model.....	360
Paper Exit Sensor.....	362
Paper Overflow Sensor.....	362
Fusing Exit Sensor.....	363
Basic model.....	363
Finisher model.....	364
Duplex Unit.....	366
Duplex Unit.....	366
By-pass Tray Unit.....	367
Duplex Entrance Sensor.....	369
Duplex Exit Sensor.....	370
Inverter Sensor.....	371
Fusing Entrance Sensor.....	373
By-Pass Paper Size Sensor.....	373

When reinstalling the by-pass paper size sensor.....	374
By-pass Paper End Sensor.....	375
By-pass Pick-up Roller	375
By-pass Feed and Separation Roller.....	376
HVPS: D.....	377
ARDF.....	379
ARDF.....	379
When installing the Platen Sheet.....	383
ARDF Rear Cover.....	384
ARDF Front Cover and Original Tray.....	384
Original Feed Unit.....	385
Pick-Up Roller.....	386
Feed Roller.....	387
Friction Pad.....	388
ARDF Drive Board.....	389
Original Set Sensor and ARDF Top Cover Sensor.....	389
Feed Motor.....	392
Feed Clutch.....	393
Transport Motor.....	393
Registration Sensor.....	395
Inverter Sensor.....	396
Cooling Fan.....	398
When installing the cooling fan.....	399
Internal Finisher.....	400
Internal Finisher.....	400
Output Tray Unit.....	402
Stapler Unit.....	402
Gathering Roller Motor.....	403
Paper Exit Motor.....	404
Shift Roller Motor.....	405
Transport Motor.....	406
Tray Lift Motor.....	406
Jogger Motor.....	408

Exit Guide Plate Motor.....	411
Shift Roller HP Sensor.....	411
Gathering Roller HP Sensor.....	412
Jogger Fence HP Sensor.....	413
Entrance Sensor.....	415
Paper Exit Sensor.....	415
Paper Sensor.....	417
Staple Tray Paper Sensor.....	417
Tray Lower Limit Sensor.....	418
Main Board.....	419
When reinstalling the main board.....	420
Electrical Components.....	421
Boards.....	421
Controller Box Cover.....	422
Controller Box.....	423
Opening the controller box.....	423
Removing the controller box.....	425
HDD.....	426
When installing a new HDD unit.....	429
Disposal of HDD Units.....	430
Reinstallation.....	430
Controller Board.....	430
Installing a New Controller Board.....	434
BCU.....	436
When installing the new BCU.....	436
Removing the BCU with bracket.....	437
NVRAM/EEPROM Replacement Procedure.....	438
SMC Report.....	439
EEPROM on the BCU.....	439
NVRAM on the Controller.....	440
IPU.....	443
PSU Box.....	443
Opening the PSU box.....	443

Removing the PSU box.....	444
PSU.....	445
HVPS: T1T2 Board.....	446
HVPS: CB Board.....	446

5. System Maintenance

Service Program Mode.....	449
SP Tables.....	449
Enabling and Disabling Service Program Mode.....	449
Entering SP Mode.....	449
Exiting SP Mode.....	449
Types of SP Modes.....	449
SP Mode Button Summary.....	450
Switching Between SP Mode and Copy Mode for Test Printing.....	450
Selecting the Program Number.....	450
Exiting Service Mode.....	451
Service Mode Lock/Unlock.....	451
Remarks.....	452
Display on the Control Panel Screen.....	452
Others.....	453
System SP1-xxx: 1.....	454
SP1-XXX (Feed).....	454
System SP1-xxx: 2.....	468
SP1-XXX (Feed).....	468
System SP2-xxx: 1.....	479
SP2-XXX (Drum).....	479
System SP2-xxx: 2.....	497
SP2-XXX (Drum).....	497
System SP2-xxx: 3.....	516
SP2-XXX (Drum).....	516
System SP2-xxx: 4.....	536
SP2-XXX (Drum).....	536
System SP2-xxx: 5.....	557
SP2-XXX (Drum).....	557

System SP2-xxx: 6.....	570
SP2-XXX (Drum).....	570
System SP3-xxx: 1.....	578
SP3-XXX (Process).....	578
System SP3-xxx: 2.....	591
SP3-XXX (Process).....	591
System SP4-xxx.....	605
SP4-XXX (Scanner).....	605
System SP5-xxx: 1.....	615
SP5-XXX (Mode).....	615
System SP5-xxx: 2.....	638
SP5-XXX (Mode).....	638
System SP5-xxx: 3.....	653
SP5-XXX (Mode).....	653
System SP5-xxx: 4.....	674
SP5-XXX (Mode).....	674
System SP6-xxx.....	699
SP6-XXX (Peripherals).....	699
System SP7-xxx: 1.....	702
SP7-XXX (Data Log).....	702
System SP7-xxx: 2.....	713
SP7-XXX (Data Log).....	713
System SP7-xxx: 3.....	725
SP7-XXX (Data Log).....	725
System SP8-xxx: 1.....	739
SP8-xxx: Data Log2.....	739
System SP8-xxx: 2.....	755
SP8-xxx: Data Log2.....	755
System SP8-xxx: 3.....	772
SP8-xxx: Data Log2.....	772
Input and Output Check.....	790
Input Check Table.....	790
Printer.....	790

Table 1: Paper Size Switch (Tray 1).....	793
Table 2: Paper Size Switch (Tray 2).....	794
Table 3: Paper Size Switch (Tray 3 and 4).....	794
ARDF.....	795
Internal Finisher.....	795
Output Check Table.....	796
Copier.....	796
ARDF.....	802
Internal Finisher.....	802
Printer Service Mode.....	803
SP1-XXX (Service Mode).....	803
Scanner Service Mode.....	813
SP1-xxx (System and Others).....	813
SP2-XXX (Scanning-image quality).....	816
Firmware Update.....	818
Type of Firmware.....	818
Before You Begin.....	819
Updating Firmware.....	820
Preparation.....	820
Updating Procedure.....	820
Error Messages.....	821
Firmware Update Error.....	822
Recovery after Power Loss.....	822
Browser Unit Update Procedure.....	822
Handling Firmware Update Errors.....	823
Error Message Table.....	823
SFU (Smart Firmware Update).....	825
Overview.....	825
SFU Procedure.....	826
How to Set a Reservation.....	828
Checking the reserved and received package information.....	830
Update the Package Firmware via SD Card.....	832
Updating JavaVM.....	834

Creating an SD Card for Updating.....	834
Updating Procedure.....	834
List of Error Messages.....	835
Installing Another Language.....	837
Reboot/System Setting Reset.....	840
Software Reset.....	840
System Settings and Copy Setting Reset.....	840
System Setting Reset.....	840
Copier Setting Reset.....	841
Controller Self-Diagnostics.....	842
Overview.....	842
Downloading Stamp Data.....	844
NVRAM Data Upload/Download.....	845
Uploading Content of NVRAM to an SD card.....	845
Downloading an SD Card to NVRAM.....	845
Address Book Upload/Download.....	847
Information List.....	847
Download.....	847
Upload.....	848
Capturing the Debug Logs.....	849
Overview.....	849
Types of debug logs that can be saved.....	849
Operation Log Security.....	850
Retrieving Debug Logs.....	851
Procedure for Retrieving the Debug Log.....	851
Card Save Function.....	853
Overview.....	853
Card Save:.....	853
Procedure.....	853
Error Messages.....	856
Test Pattern Printing.....	857
6. Troubleshooting	
SC Tables.....	859

Service Call Conditions.....	859
Summary.....	859
SC Code Classification.....	860
Service Call 1xx.....	862
SC1xx: Scanning.....	862
Service Call 2xx.....	867
SC 2xx: Exposure.....	867
Service Call 3xx.....	873
SC3xx: Image Processing – 1.....	873
SC3xx: Image Processing – 2.....	874
Service Call 4xx.....	877
SC4xx: Image Processing - 3.....	877
Service Call 5xx.....	882
SC5xx: Paper Feed and Fusing.....	882
Service Call 6xx.....	895
SC6xx: Device Communication.....	895
Service Call 7xx.....	907
SC7xx: Peripherals.....	907
Service Call 8xx.....	911
SC8xx: Overall System.....	911
Service Call 9xx.....	931
SC9xx: Miscellaneous.....	931
Process Control Error Conditions.....	938
Developer Initialization Result.....	938
Process Control Self-Check Result.....	939
Vsg Adjustment Result.....	941
Line Position Adjustment Result.....	941
Troubleshooting Guide.....	943
Line Position Adjustment.....	943
Test.....	943
Countermeasure list for color registration errors.....	943
Problem at Regular Intervals.....	949
Blank Print.....	951

All-black Print.....	951
Missing CMY Color.....	952
Light Print.....	952
Repeated Spots or Lines on Prints.....	952
Dark Vertical Line on Prints.....	953
White Horizontal Lines or Bands.....	954
Missing Parts of Images.....	954
Dirty Background.....	954
Partial CMY Color Dots.....	955
Dark Irregular Streaks on Prints.....	955
CMY Color Irregular Streaks.....	955
Ghosting.....	955
Unfused or Partially Fused Prints.....	956
Image Skew.....	956
Background Stain.....	957
No Printing on Paper Edge.....	957
Image not centered when it should be.....	957
Light Density (SC360, SC361, SC362, SC363).....	958
Symptom.....	958
Possible Causes.....	959
Necessary Actions.....	960
PCDU Installation (SC312, SC313, SC314, SC315).....	962
Symptom.....	962
Possible Causes.....	962
Necessary Actions.....	962
Jam Detection.....	967
Paper Jam Display.....	967
Jam Codes and Display Codes.....	967
Paper Size Code.....	971
Electrical Component Defects.....	972
Sensors.....	972
Blown Fuse Conditions.....	977
Power Supply Unit.....	977

Scanner Test Mode.....	978
SBU Test Mode.....	978

7. Energy Saving

Energy Save.....	979
Energy Saver Modes.....	979
Timer Settings.....	979
Return to Stand-by Mode.....	980
Recommendation.....	980
Paper Save.....	981
Effectiveness of Duplex/Combine Function.....	981
1. Duplex:.....	981
2. Combine mode:.....	981
3. Duplex + Combine:.....	981
How to calculate the paper reduction ratio	982

1. Product Information

Specifications

1

See "Appendices" for the following information:

- Specifications
- Supported Paper Sizes
- Software Accessories
- Optional Equipment

Guidance for Those Familiar with Predecessor Products

1

Basic Machine Configuration

The previous series featured four models, two "standard" machines without the internal finisher (30 ppm and 40 ppm) and two "finisher" machines with the internal finisher (30 ppm and 40 ppm).

Previous Models

M022	C1a Std. 30 ppm	No internal finisher
M026	C1b Std. 40 ppm	No internal finisher
M024	C1a Fin. 30 ppm	Standard internal finisher
M028	C1b Fin. 40 ppm	Standard internal finisher

The new series features only two models, one "standard" machine without the internal finisher, and one "finisher" machine with the internal finisher.

New Models

D191	C2b Std. 40 ppm	No internal finisher
D193	C2b Fin. 40 ppm	Standard internal finisher

The two machines in the new series are both 40 ppm. The 30 ppm models have been discarded for the new series.

New General Features

Here is a brief summary of some new features of the new machine.

- **GW+ Controller.** This is an advanced controller for high end A4 color MFP machines. GW+ is embedded and can offer the same solutions as other Ricoh products.
- **Power Consumption.** Power consumption in low power mode is reduced from 2.5 W to 1.0 W (about 40% down).
- **Recovery Time from Low Power Mode.** The operator can use the operation panel within 4 sec. after low power mode recovery, and copying can start within 5.5 sec.
- **Silent Mode.** This machine is the first Ricoh product to support silent mode. After setting the machine for Silent Mode, print jobs will start automatically with less noise. Documents can be printed quietly

in libraries, meeting areas, etc. where people do not want to be disturbed by the noise of machine operation. Standard productivity is 40 ppm; however, in Silent Mode priority is given to less noise and consequently productivity lowers to 15 ppm.

- **Operation Panel.** The standard 9-inch operator panel can be replaced with an optional Smart Operation Panel. The Smart Operation Panel allows you to register frequently used functions, customize the Home screen, manage machine status and jobs, browse Web pages on the operation panel, send scan files to email, and so on.

Options

Machine Options

These hardware options are the same for the previous and new models.

No.	M022/M026, M024/M028	D191/D193
1	1-Bin Tray Unit BN1000 (M370): M022/M026 only	Same: D191 only
2	Side Tray Type C400 (M369)	Same
3	Paper Feed Unit PB1000 (M367)	Same
4	Paper Feed Unit PB1010 (M368)	Same

Controller Options

There are some differences in the controller options available for the previous and new models.

No.	M022/M026, M024/M028	D191/D193
1	Bluetooth Interface Unit Type D (D566)	Same
2	Browser Unit (D430)	Browser Unit Type M10 (D792-03, -04)
3	--- (PictBridge standard)	Camera Direct Print Card Type M10 (D792-07)
4	File Format Converter Type E (D377-04)	Same
5	Gigabit Ethernet Type B (D377-21)	Discontinued
6	IEEE 802.11a/g Interface Unit Type J (D377-01)	IEEE 802.11 Interface Unit Type O (M417-06)

No.	M022/M026, M024/M028	D191/D193
7	---	DataOverwriteSecurity Unit Type H (D377-22)
8	---	OCR Unit Type M2 (D166)
9	---	SD Card for NetWare Printing Type M10 (D792-06)
10	---	XPS Direct Print Option Type M10 (D792-08)

↓ Note

- Data Overwrite Security function (Data Overwrite Security Unit Type H D377) is built into the controller board but not enabled before shipping. It must be enabled with SP5-878-001. (SP5-878-001 Data Overwrite Security > [EXECUTE])
- Hard disk encryption (HDD Encryption Unit Type A D377) is built into the controller board but not enabled before shipping. It must be enabled with SP5-878-002. (SP5-878-002 HDD Encryption > [EXECUTE])

Fax Options

The name of the fax unit has changed, but there is no change in the fax installation procedures.

No.	M022/M026, M024/M028	D191/D193
1	Fax Option Type C400 (D483)	Fax Option Type M10 (D791-01, -02)
2	---	Fax Connection Unit Type M10 (D791-04)
3	Memory Unit Type B 32 MB (G578)	Same

Other

There are some differences in the extra options for the previous and new models.

No.	M022/M026, M024/M028	D191/D193
1	---	Enhanced Security HDD Option Type M10 (D792-09)
2	---	Smart Operation Panel Type M10 (D190)
3	Optional Counter Interface Unit Type A (B870)	Same

No.	M022/M026, M024/M028	D191/D193
4	Copy Data Security Unit Type F (B829)	Copy Data Security Unit Type G (D640)

↓ Note

- Items 1 and 2 are new options for D191/D193.
- The type of the Copy Data security Unit has changed but the installation procedure is the same.

Machine Exterior

Decal

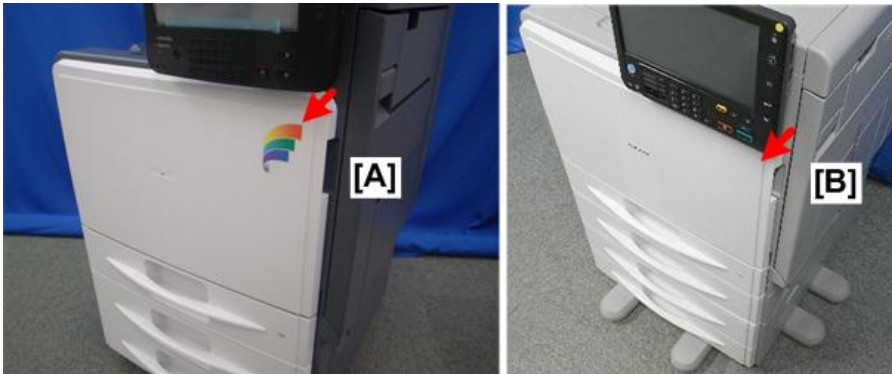

d191b9009

The decal on the front door of the previous machine [A] has been removed from the door of the new machine [B].

Operation Panel

There are some differences in the operation panels for the previous and new models.

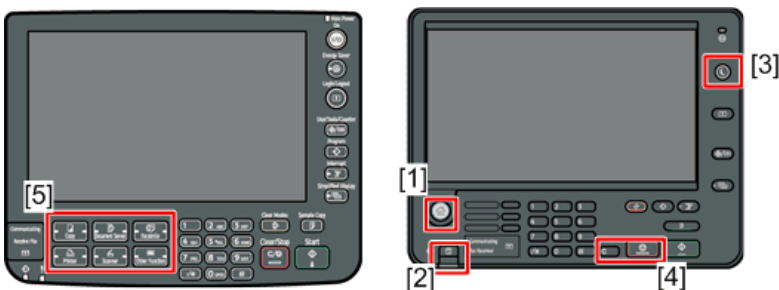

d191z5010

No.	M022/M026, M024/M028	D191/D193
1	---	[Home] key Press to display the [Home] screen.
2	---	[Check Status] key Press to check the machine's system status, operational status of each function, and current jobs. You can also display the job history and the machine's maintenance information.
3	---	[Energy Saver] key Press to switch to and from Low Power mode or Sleep mode. When the machine is in Low Power mode, the [Energy Saver] key is lit. In Sleep mode, the [Energy Saver] key flashes slowly.
4	[Stop/Clear] key	[Stop/Clear] key is divided into two keys: [Clear] and [Stop].
5	Function keys at default	No function keys by default

Right Rear Corner Cover

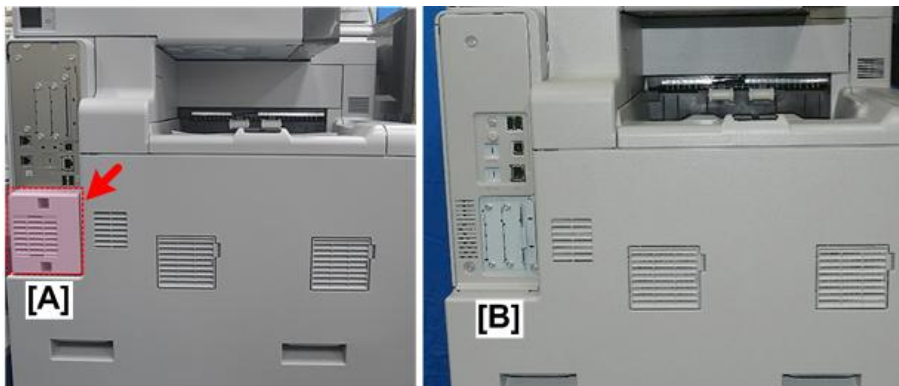

d191b9005

The small cover at the left rear corner of the previous machine [A] has been eliminated on the new machine [B].

Controller Board Faceplate Layout

The new machine has a new controller board. The slots of the controller board have been rearranged.

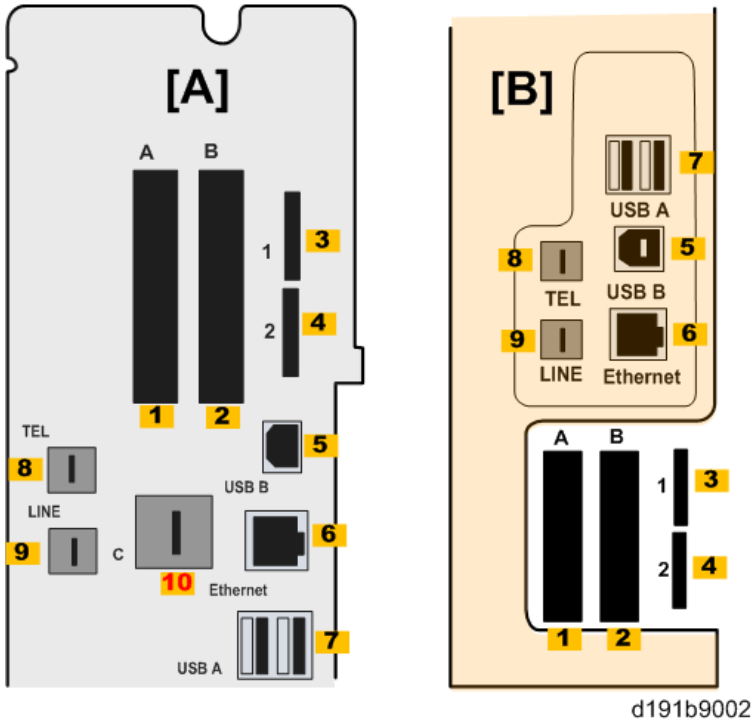

Layout [A] is the previous machine, and layout [B] is the new machine.

No.	Name	For
1	Slot A	Wireless LAN
2	Slot B	File Format Converter
3	SD Card Slot 1	Application Slot
4	SD Card Slot 2	Service Slot
5	USB B	USB 2.0 I/F cable
6	Ethernet	Network Connection
7	USB A	Bluetooth
		Digital Camera
8	TEL	Telephone Cord (for Fax)

No.	Name	For
9	LINE	For Fax
10	C	Gigabit Ethernet (previous machine only)

SD Card Storage Location



d191b9003

The SD cards were stored in cover [A] at the left rear corner of the previous machine but this cover has been eliminated. The SD cards can be stored behind the controller faceplate cover [B] of the new machine. Slots are provided for the storage of three SD cards.

Main Power Switch

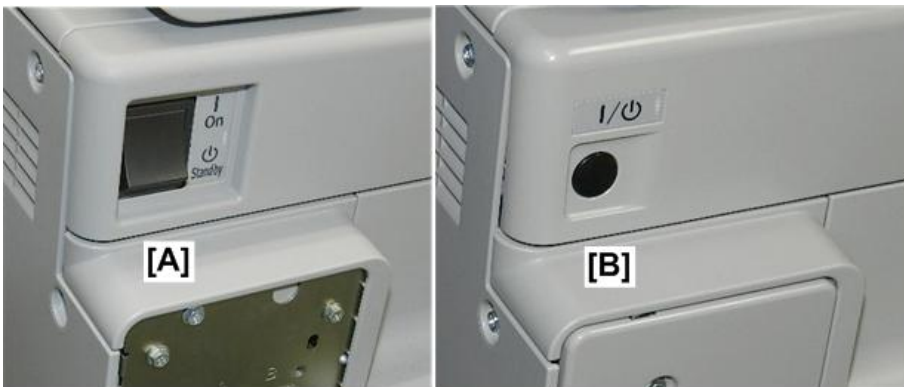

d191b9011

The square flip switch [A] of the previous machine has been replaced with a round push-switch [B] on the new machine. The power switch is at the same location (rear left corner). There is no power switch on the operation panel of the new models.



d191b0075

1. Press the power switch on the left rear corner of the machine.
2. After the "Please Wait" message goes off, touch [Copier] on the operation panel display.
3. When you are ready to turn the machine off, press the power switch. A message is displayed.

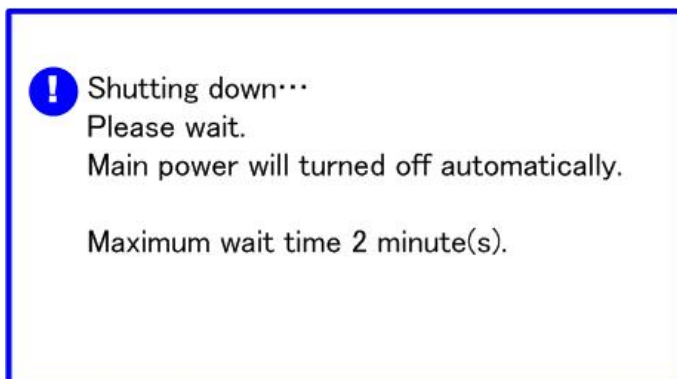

d191b0074

Note

- This gives the hard disk drive enough time to stop rotating and to shut down safely before the machine loses power.
4. Wait for the machine to go off automatically. When the operation panel display goes off, the machine is off.

★ Important

- **There is no power switch on the operation panel.**
5. Before servicing the machine, disconnect the power cord and allow the machine to sit idle for a few minutes.

CAUTION

- To avoid personal injury, always wait a few minutes for hot components inside the machine to cool before removing the covers.
- Allowing the machine to remain off before servicing also allows residual voltage on the boards to disperse.

For details about the main power switch, see “Notes on the Main Power Switch” (page 193).

ADF

The ADF of the previous and new machines is the same basic design. However, the base hinges of the ADF have been improved to increase their durability, and rubber pads have been added to reduce noise.

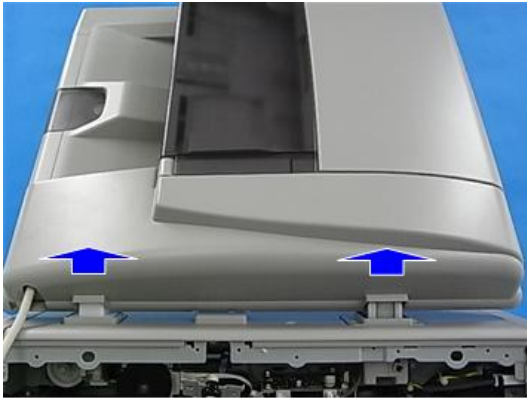

d191b9020

The ADF of the previous machine could be removed with the removal of one hinge screw (left hinge).

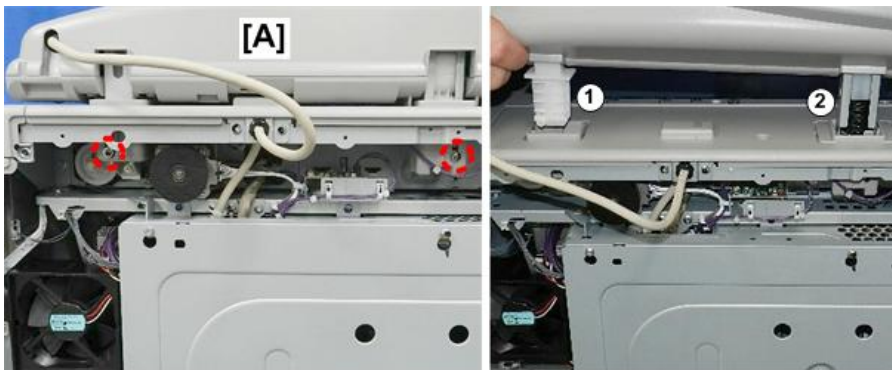

d191b9012

However, removal of ADF [A] of the requires the removal of two screws, one fastened to the right hinge ① and one fastened to the left hinge ②.

Small rubber pads have been added at three locations to reduce the noise when opening and closing the feed cover and original tray of the ADF.

Feed Cover

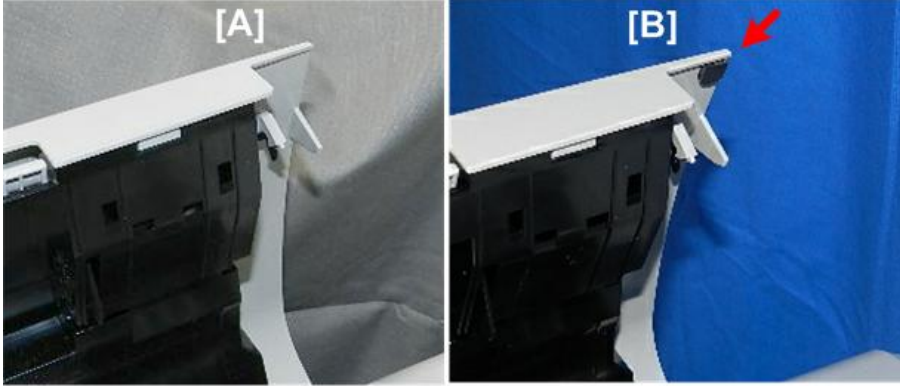

d191b9013

No pad on the feed cover [A] of the previous models, and a rubber pad on the feed cover [B] of the new models.

Transparent Cover

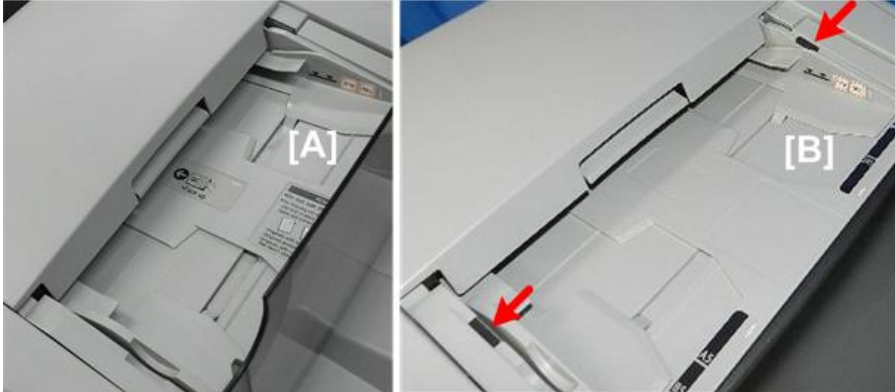

d191b9014

No pads under the transparent cover of the previous models [A], and two rubber pads added on the new models [B].

Original Tray

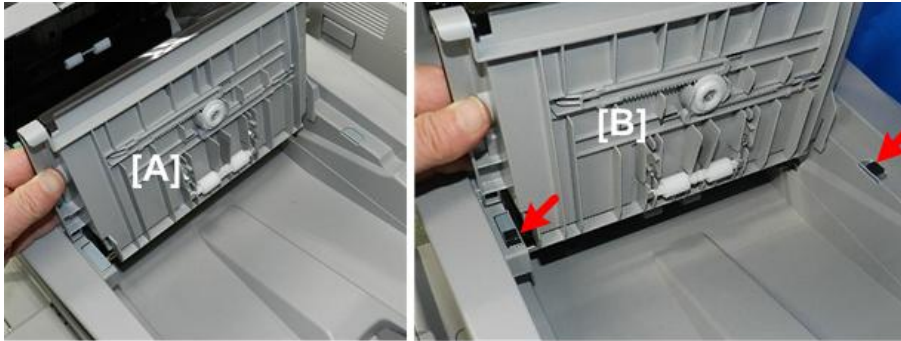

d191b9015

No pads under the original table of the previous models [A], and two rubber pads added on the new models [B].

Boards

IPU (Rear)



d191b9016

There are some slight changes in the routing of cables and wires at the upper right corner of the IPU. The clutter of the previous models [A] has been corrected in the new models [B].

①	The I/F cable was shortened and clamped.
②	The ground wire was also shortened and clamped.
③	The I/F cable was shortened and connectors shape of were changed.

Scanner Unit IDB

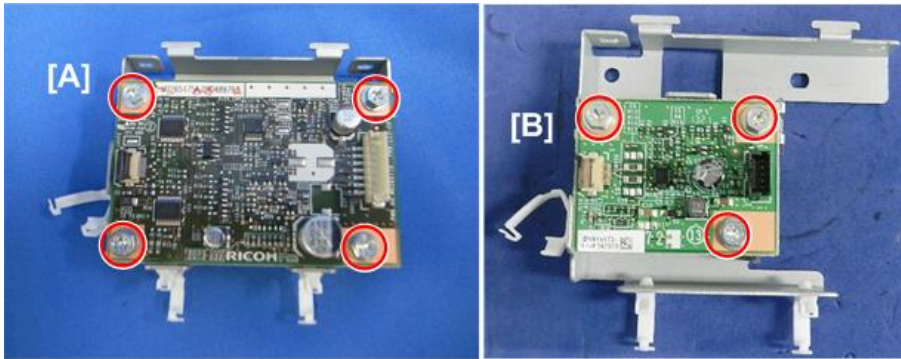

d191b9004

The LED-DB of the previous machine [A] has been replaced with a new one (IDB) [B]. The previous LED-DB is fastened to the bracket with four screws and the new one (IDB) is fastened with only three screws. The shape of the bracket has also changed.

Controller Board

The new models have a new controller board.

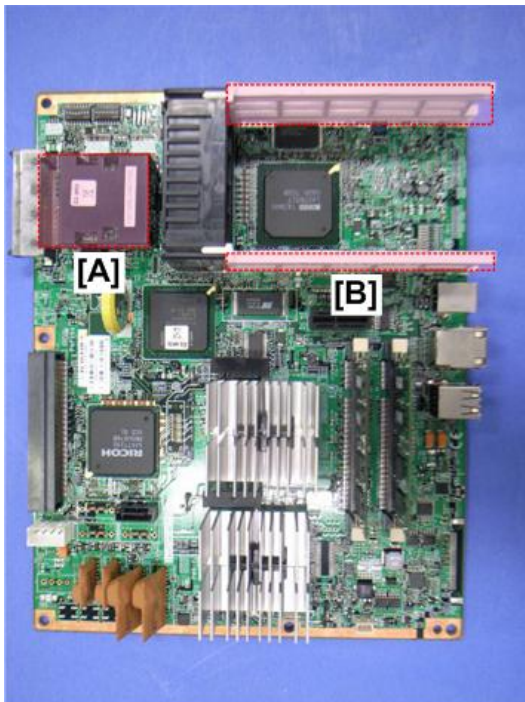

d191b9017

The single NVRAM [A] on the controller board of the previous models is located at the upper left corner, and the option board racks [B] are mounted high on the right.

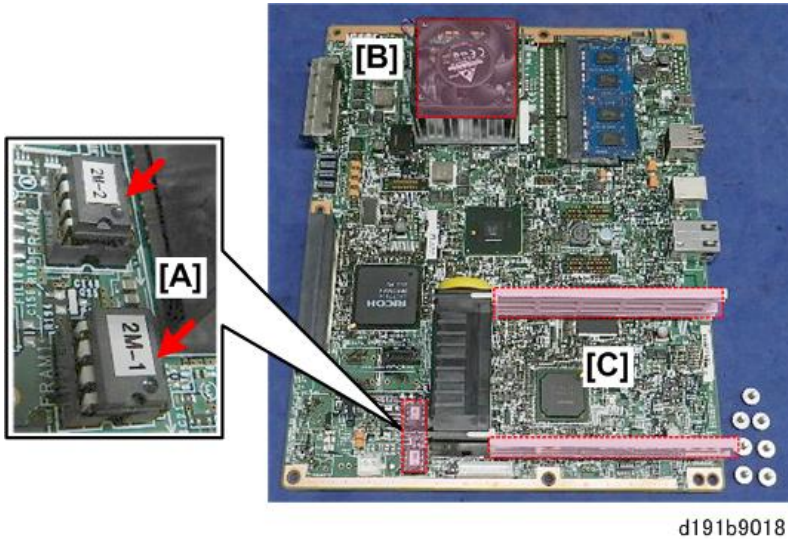

The dual NVRAMs [A] on the controller board of the new models are located at the lower left corner. The new controller board has an on-board cooling fan [B]. The option board racks [C] are mounted low on the right.

Controller Fan

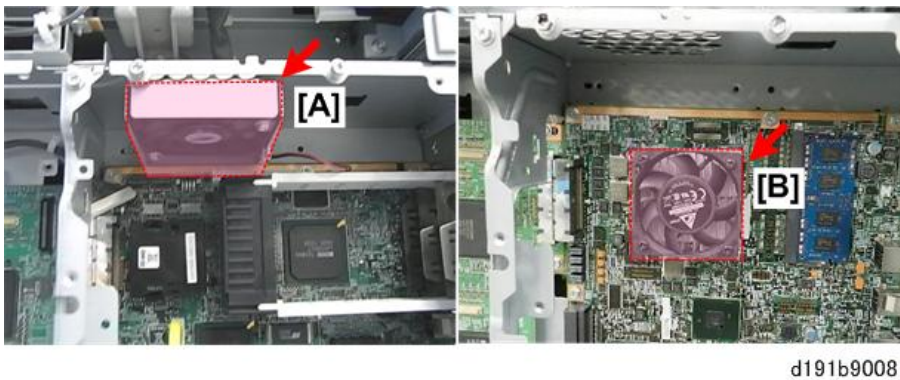

The controller fan [A] of the previous models has been eliminated and replaced by the cooling fan [B] mounted directly on the new controller board.

SDB Eliminated

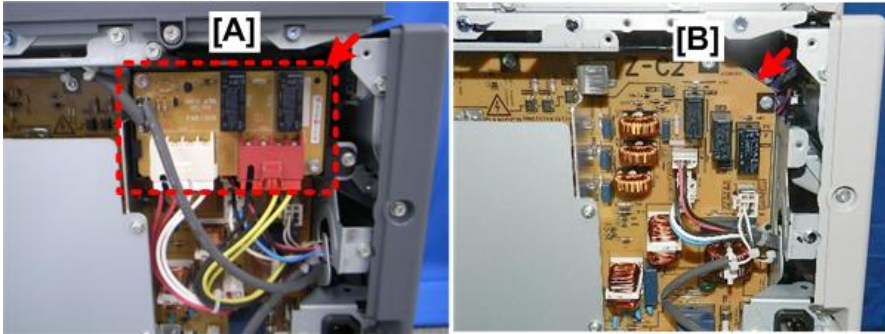

d191b9007

The SDB (Shutdown Board) [A] of the previous models has been eliminated. The function of the SDB is built into the PSU [B].

HDD Unit (Standard)



d191b9019

The standard HDD unit [A] of the previous models is larger than the HDD unit [B] of the new models. Also, the shapes of the mounting brackets are different. The capacity of the HDD is 160GB for the previous models and 320 GB for the new models.

HDD Unit (Option)



d191b9010

A new HDD option is available for D191/D193. This HDD unit is a self-encrypting drive that prevents security breaches.

★ Important

- If this option is used, the standard HDD unit in the machine must be removed and replaced with this optional HDD unit.
- The system administrator can consolidate the drive through a network. An Authentication Code is required in the Administrator Settings.
- Once this option is installed, if the HDD unit is removed from the machine and connected to an unauthorized host system, the encryption keys and data are instantly invalidated.
- This new "wipe technology" meets Federal Information Processing Standards (FIPS 14-2), developed by the National Institute of Standards and Technology (NIST) for Federal computer systems and approved by the US Secretary of Commerce.

Machine Configuration

1

Machine Configuration

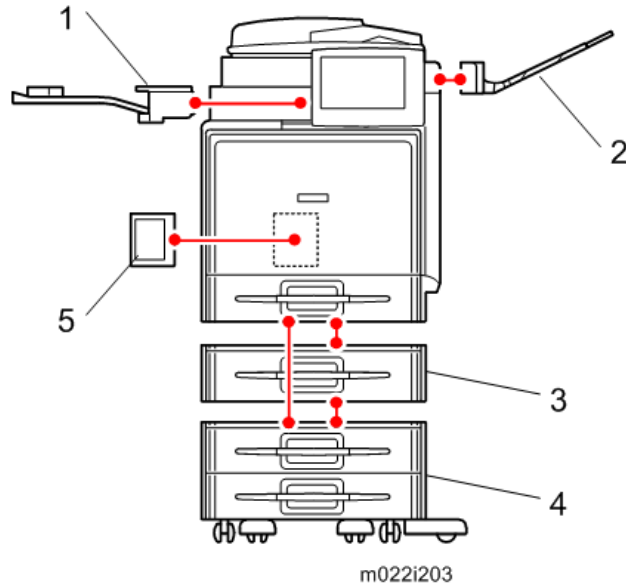

Main machine

Item	Machine Code	Remarks
Main Unit	D191/D193	C2b Std. 40 ppm C2b Fin. 40 ppm

Options

	Item	Machine Code	Remarks
1	1 Bin Tray BN1000	M370	-
2	Side Tray Type C400	M369	-
3	Paper Feed Unit PB1000	M367	-
4	Paper Feed Unit PB1010	M368	-

5	Fax Option Type M10	D791-01 NA D791-02 EU	-
-	Memory Unit Type B 32MB	G578-17	SAF memory requires the Fax Option.
-	Browser Unit Type M10	D792-03 NA D792-04 EU	SD card Slot 2
-	IEEE 802.11 Interface Unit Type O	M417-06	I/F slot A
	File Format Converter Type E	D377-04	I/F slot B
	Copy Data Security Unit Type G	D640-41	-
	Optional Counter Interface Unit Type A	B870-11	-

Overview

1

Component Layout

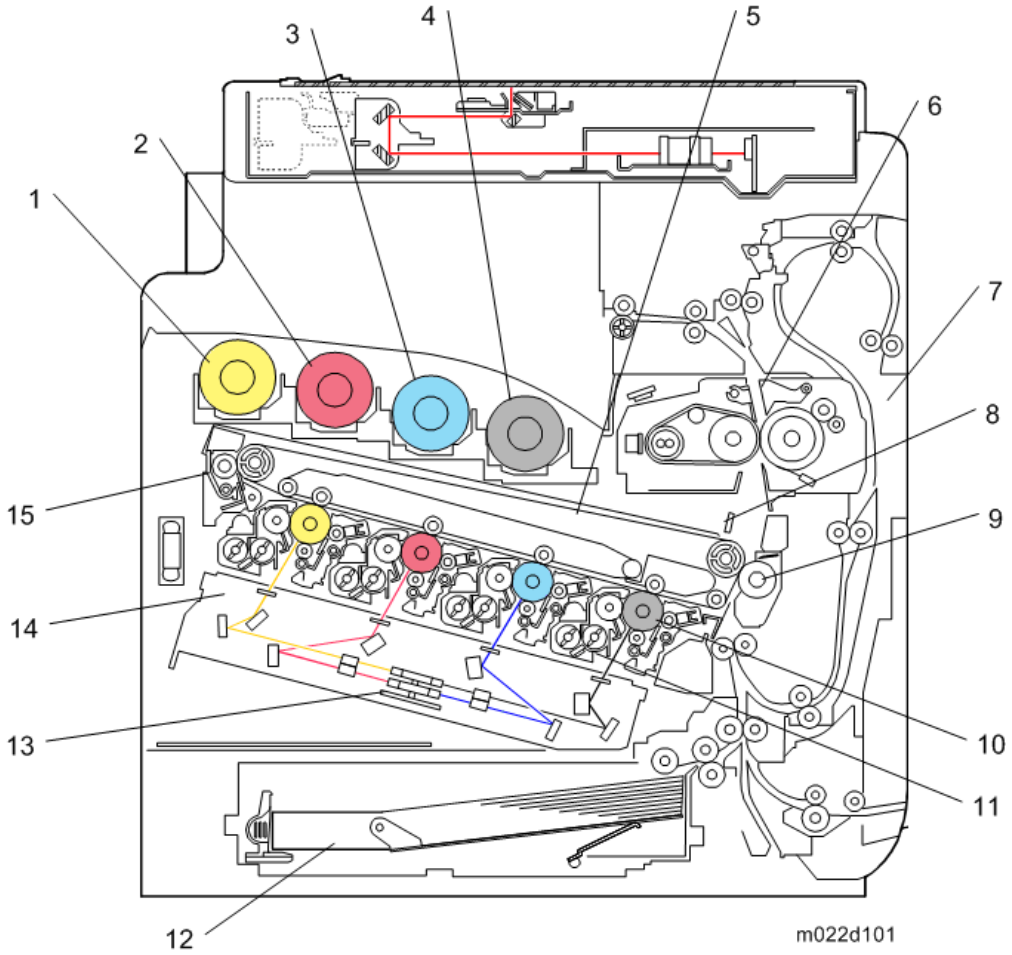

<ul style="list-style-type: none"> 1. Toner Bottle [Y] 2. Toner Bottle [M] 3. Toner Bottle [C] 4. Toner Bottle [K] 5. Image Transfer Belt Unit 6. Fusing Unit 7. Duplex Unit 8. ID Sensor 	<ul style="list-style-type: none"> 9. Paper Transfer roller 10. PCU (Photo Conductor Unit) 11. Development Unit 12. Standard Paper Feed Tray (Tray 1) 13. Polygon Mirror Motor 14. LDU 15. Image Transfer Belt Cleaning Unit
---	---

Paper Path

Standard model (Basic)

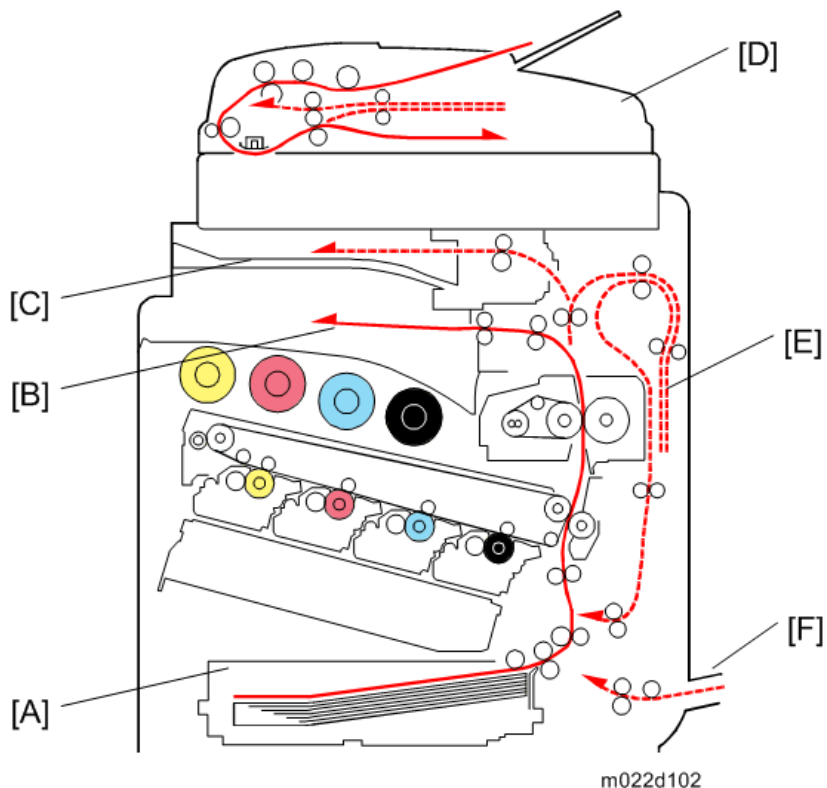

[A]: Standard Paper Feed Tray (Tray 1)

[B]: Standard Paper Exit Tray

[C]: 1 Bin Tray

[D]: ARDF

[E]: Duplex Unit

[F]: By-pass Tray

1

Standard model (Full option)

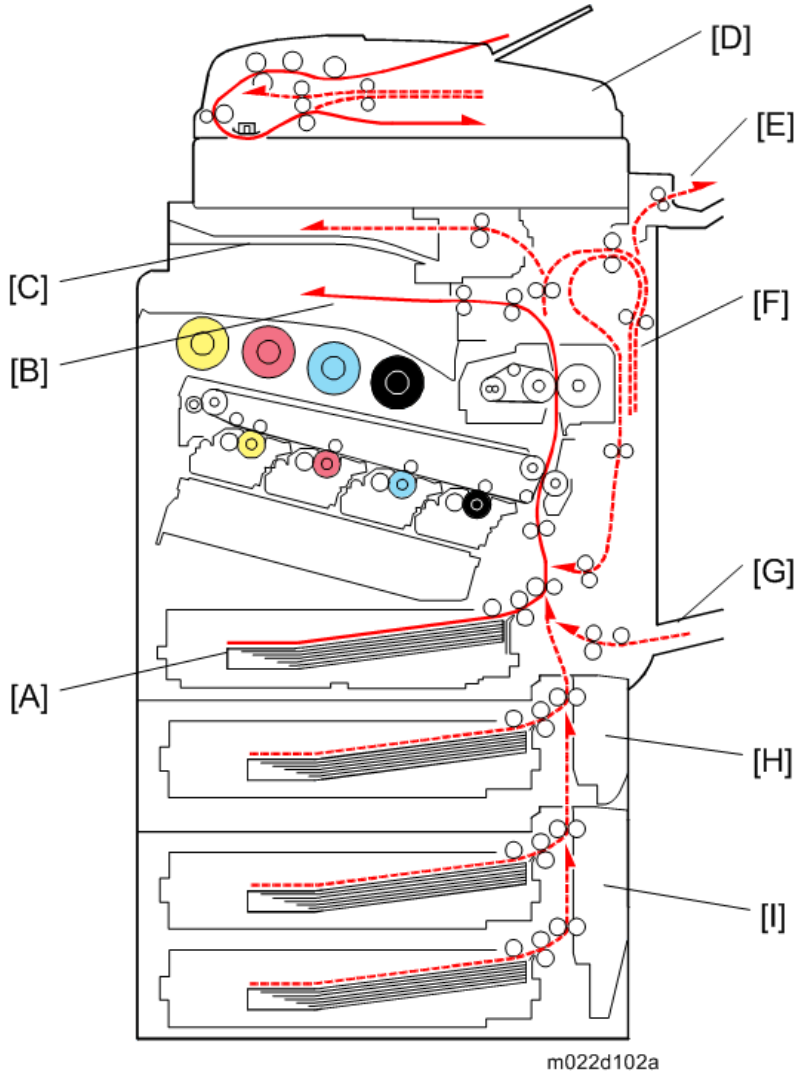

[A]: Standard Paper Feed Tray (Tray 1)

[B]: Standard Paper Exit Tray

[C]: 1 Bin Tray

[D]: ARDF

- [E]: Side Tray
- [F]: Duplex Unit
- [G]: By-pass Tray
- [H]: One Tray Paper Feed Unit (Option)
- [I]: Two Tray Paper Feed Unit (Option)

Finisher model (Basic)

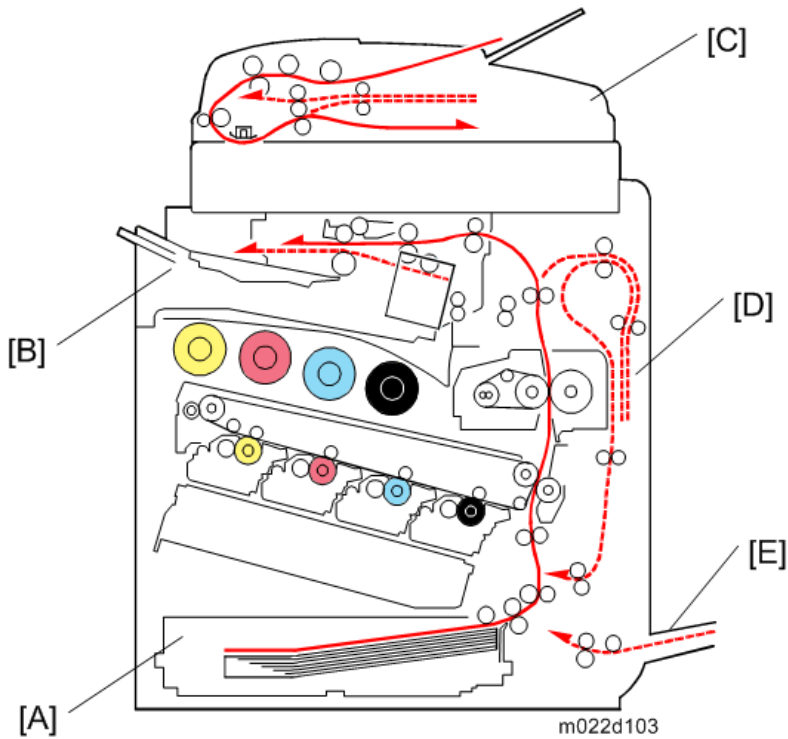

- [A]: Standard Paper Feed Tray (Tray 1)
- [B]: Internal Finisher
- [C]: ARDF
- [D]: Duplex Unit
- [E]: By-pass Tray

Finisher model (Full option)

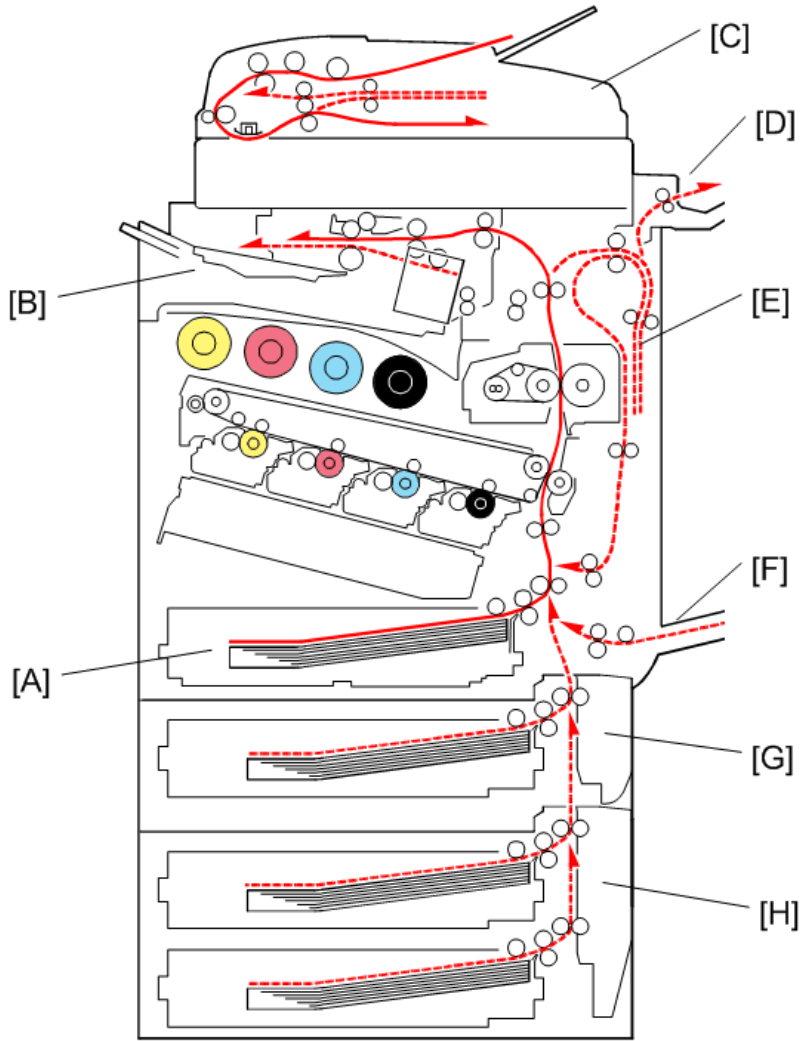

m022d103a

[A]: Standard Paper Feed Tray (Tray 1)

[B]: Internal Finisher

[C]: ARDF

[D]: Side Tray

[E]: Duplex Unit

[F]: By-pass Tray

[G]: One Tray Paper Feed Unit (Option)

[H]: Two Tray Paper Feed Unit (Option)

Drive Layout

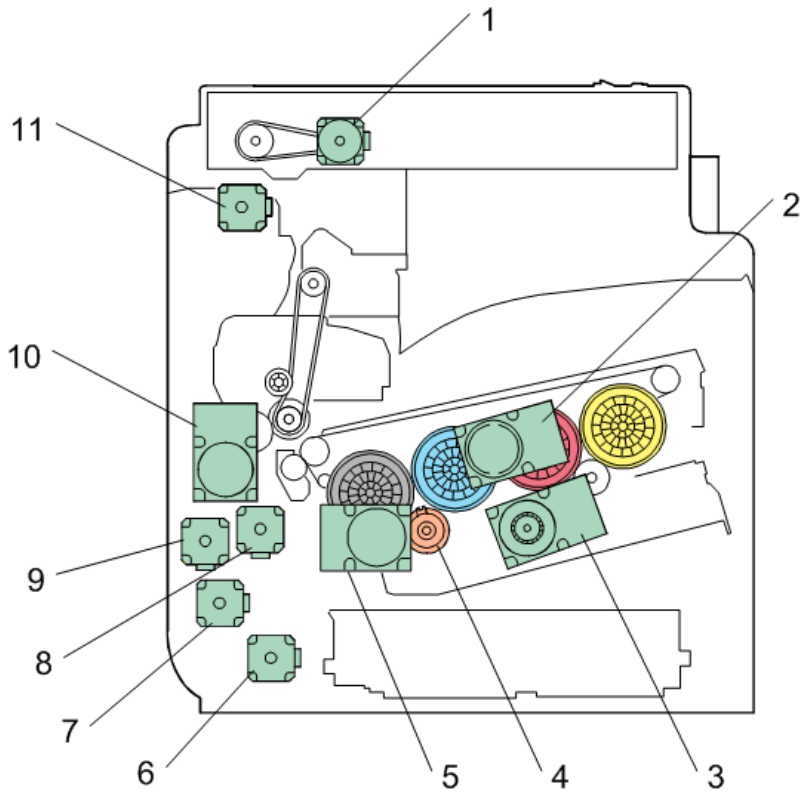

m022v103

1. Scanner Motor:
Drives the scanner unit.
2. Drum Motor: CMY:
This controls the OPCs for cyan, magenta, and yellow.
3. Development Motor: CMY:
This controls the color development units (cyan/ magenta/ yellow).
4. Development Clutch: K:
This controls the drive power to the development unit-K.
5. ITB Unit/ Drum: K/ Development: K Motor:
This controls the black OPC, development unit for black, and ITB unit.
6. Paper Feed Motor:
This controls the paper feed mechanisms (tray 1).
7. Vertical Transport Motor:

This controls the vertical transport roller.

8. Registration Motor:

This controls the registration rollers.

9. Duplex/ By-pass Motor:

This controls the duplex entrance, relay, exit, by-pass and separation rollers.

10. Fusing/ Paper Exit Motor:

This controls the fusing unit and paper exit rollers.

11. Inverter Motor:

This controls the inverter roller.

2. Installation

Installation Requirements

Environment

2

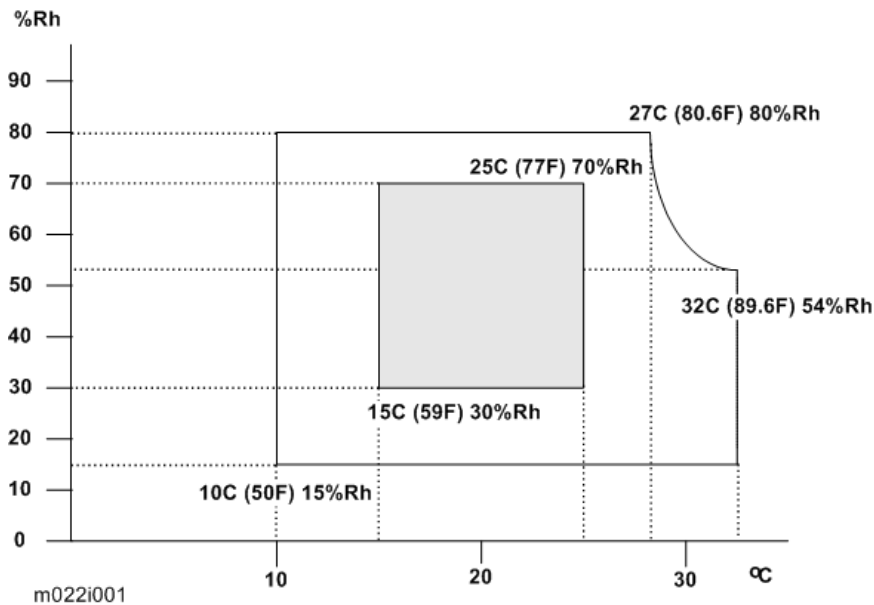

1. Temperature Range: 10°C to 32°C (50°F to 89.6°F)
2. Humidity Range: 15% to 80% RH
3. Ambient Illumination: Less than 1500 lux (do not expose to direct sunlight)
4. Ventilation: 3 times/hr/person or more
5. Do not let the machine get exposed to the following:
 - 1) Cool air from an air conditioner
 - 2) Heat from a heater
6. Do not install the machine in areas that are exposed to corrosive gas.
7. Install the machine at locations lower than 2,000 m (6,500 ft.) above sea level.
8. Install the machine on a strong, level base. (Inclination on any side must be no more than 5 mm.)
9. Do not install the machine in areas that get strong vibrations.

Machine Level

Front to back: Within 5 mm (0.2")

Right to left: Within 5 mm (0.2")

2

Machine Space Requirements

CAUTION

- This machine, which uses high voltage power sources, can generate ozone gas. High ozone density is harmful to human health. Therefore, the machine must be installed in a well-ventilated room.

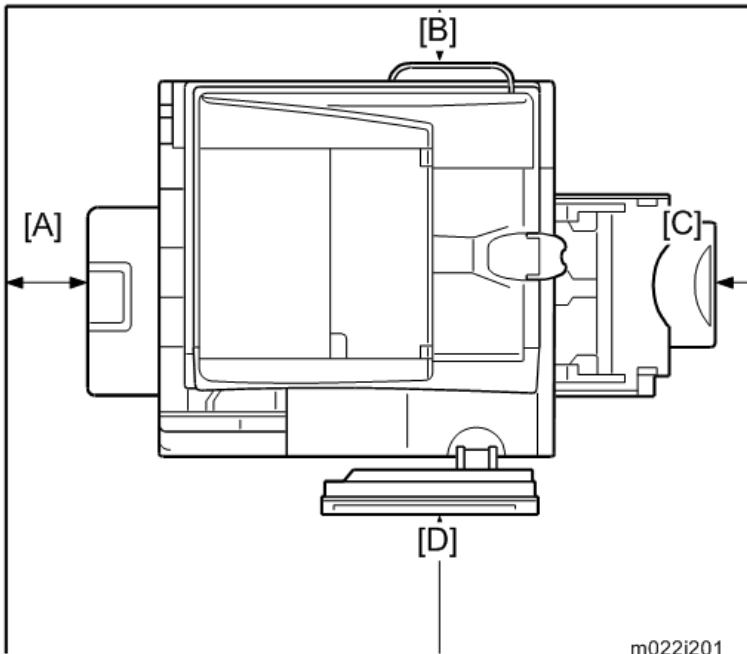

m022i201

A: Over 100 mm (3.9")

B: Over 100 mm (3.9")

C: Over 315 mm (12.4")

D: Over 400 mm (15.7")

Put the machine near the power source with the clearance shown above.

Machine Dimensions

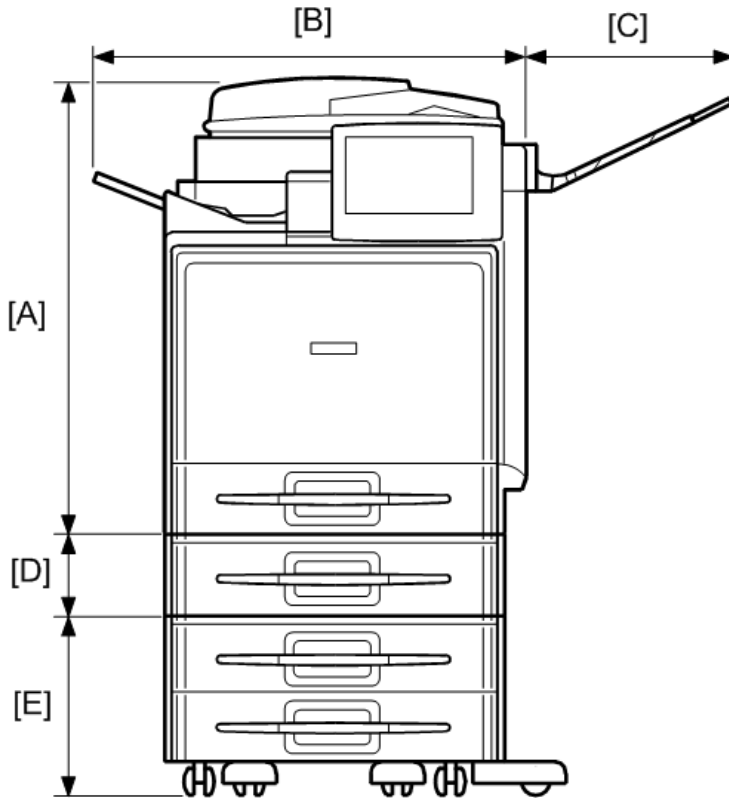

m022i202

[A]: 710 mm

[B]: 580 mm

[C]: 315 mm

[D]: 120 mm

[E]: 270 mm

Power Requirements

⚠ CAUTION

- Insert the plug firmly in the outlet.
- Do not use an outlet extension plug or cord.
- Ground the machine.

1. Input voltage level:

- 120 to 127 V, 60 Hz: More than 12 A
- 220 V to 240 V, 50 Hz/60 Hz: More than 8 A

2. Permissible voltage fluctuation:

NA: 108 V (120 V-10%) - 138 V (127 V+8.66 %)

EU/AA: 198 V (220 V-10%) - 264 V (240 V+10 %)

3. Do not put things on the power cord.

Optional Unit Combinations

Machine Options

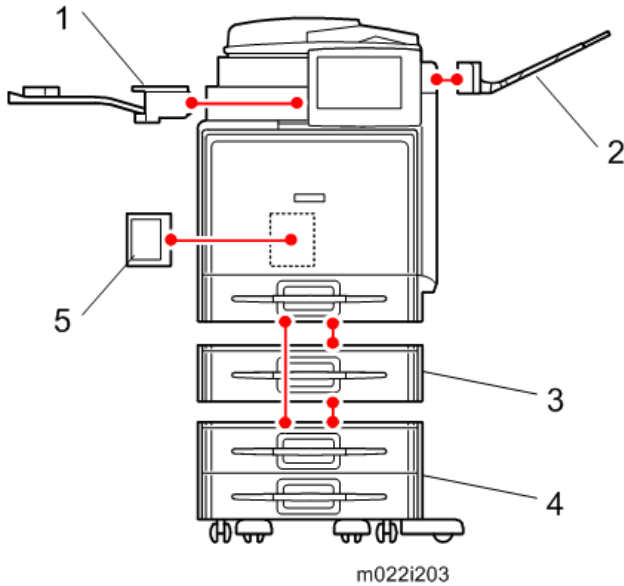

2

No.	Options		Remarks
	D191	D193	
1	1 Bin Tray BN1000	-	-
2	Side Tray Type C400		-
3	Paper Feed Unit PB1000		-
4	Paper Feed Unit PB1010		-
5	Fax Option Type M10		-
6	Enhanced Security HDD Option Type M10		-
7	Smart Operation Panel Type M10		-

Controller Options

No.	Options		Remarks
	D191	D193	
1	IEEE 802.11 Interface Unit Type O		I/F slot A
2	File Format Converter Type E		I/F slot B
3	Bluetooth Interface Unit Type D		USB A
4	DataOverwriteSecurity Unit Type H		SD card slot 1
5	Browser Unit Type M10		SD card slot 1
6	OCR Unit Type M2		SD card slot 2 (during installation only)
7	Camera Direct Print Card Type M10		SD card slot 1
8	SD card for NetWare printing Type M10		SD card slot 1
9	XPS Direct Print Option Type M10		SD card slot 1

Fax Options

No.	Options		Remarks
	D191	D193	
1	Fax Option Type M10		-
2	Memory Unit Type B 32MB		-
3	Fax Connection Unit Type M10		-

Other Options

No.	Options		Remarks
	D191	D193	
1	Copy Data Security Unit Type G		-

2	Optional Counter Interface Unit Type A	-
---	--	---

Copier Installation

Installation Flow Chart

2

Basic model

This flow chart shows the best procedure for installation.

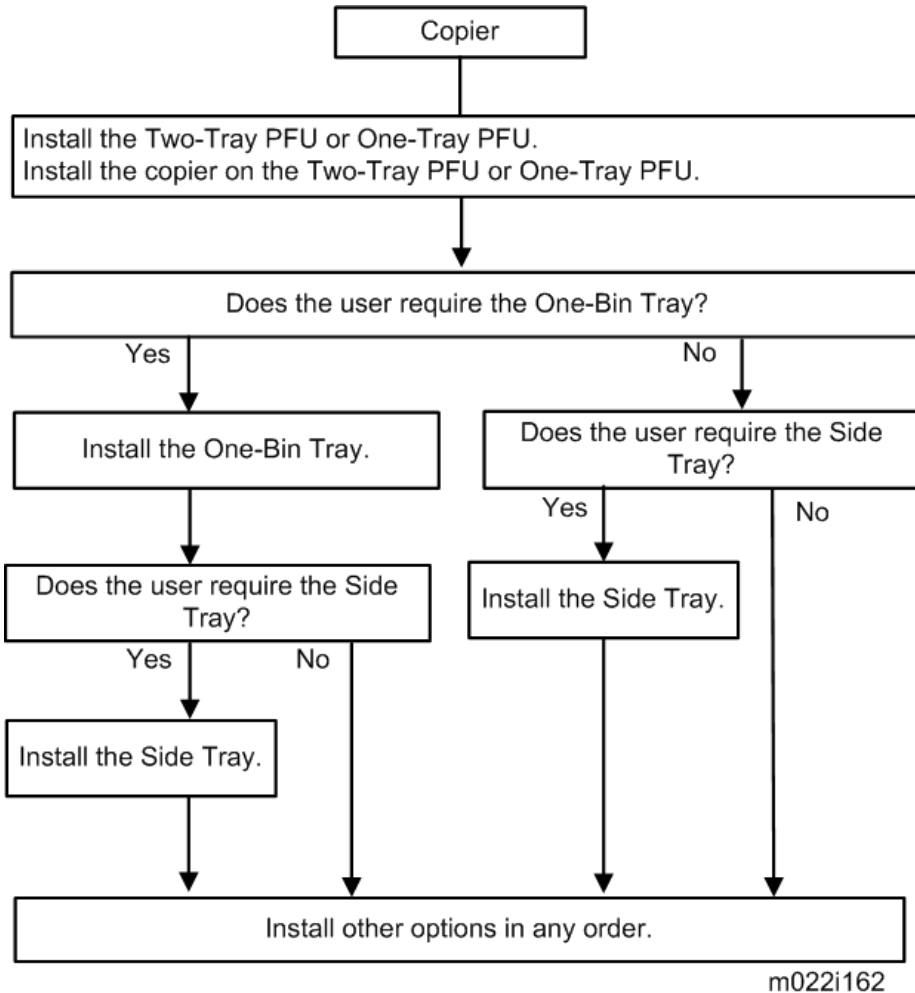

Finisher model

This flow chart shows the best procedure for installation.

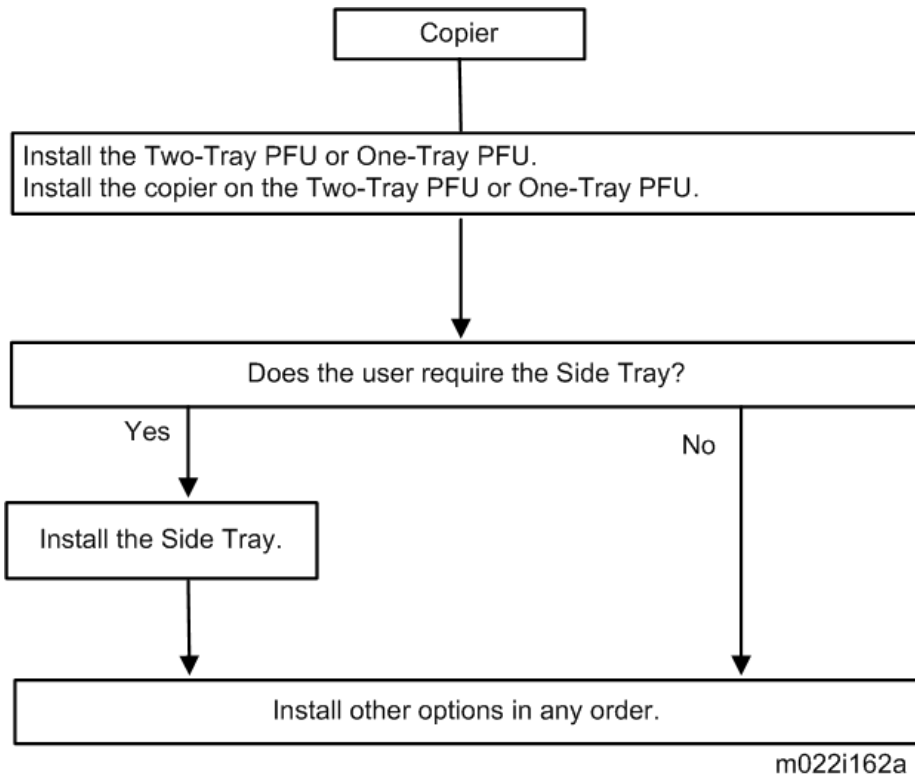

Accessory Check

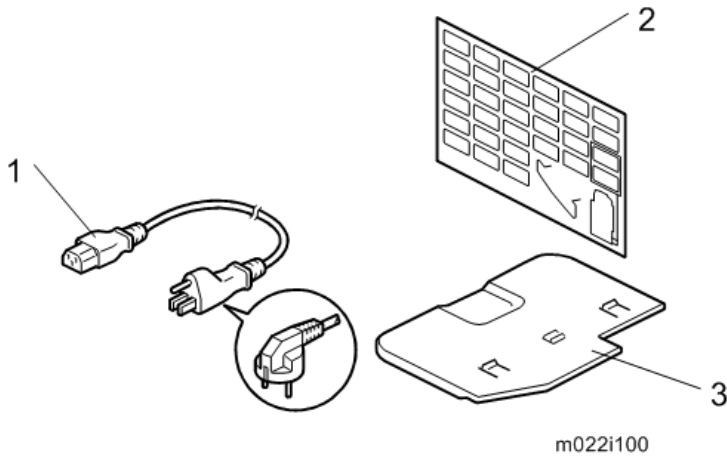

Check the quantity and condition of these accessories.

For D191

No.	Description	Q'ty
1	Power Supply Cord	1
2	Decal - Paper Size	1
-	Emblem Decal	1

For D193

No.	Description	Q'ty
1	Power Supply Cord	1
2	Decal - Paper Size	1
3	Left tray	1
-	Emblem Decal	1

Installation Procedure

Put the machine on the paper tray unit first if you install an optional paper feed unit at the same time. Then install the machine and other options.

Note

- Keep the shipping retainers after you install the machine. You may need them in the future if you transport the machine to another location.



d191b0001

The arrangement of tape and shipping materials is basically the same for both models. However, the shape and size of the cushion under the ADF on the left are slightly different. Both are easily removed.

Tapes, Retainers and Toner Bottles

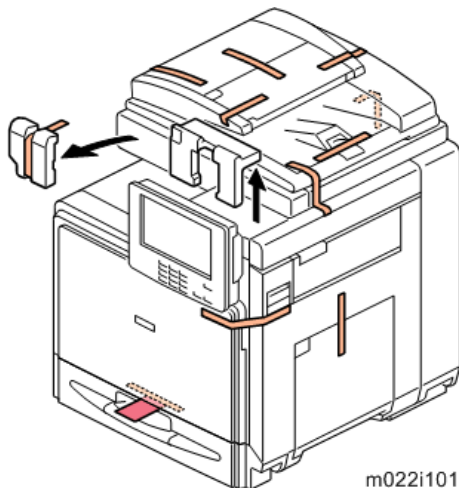

m022i101

1. Remove the tapes and the retainers on the machine.

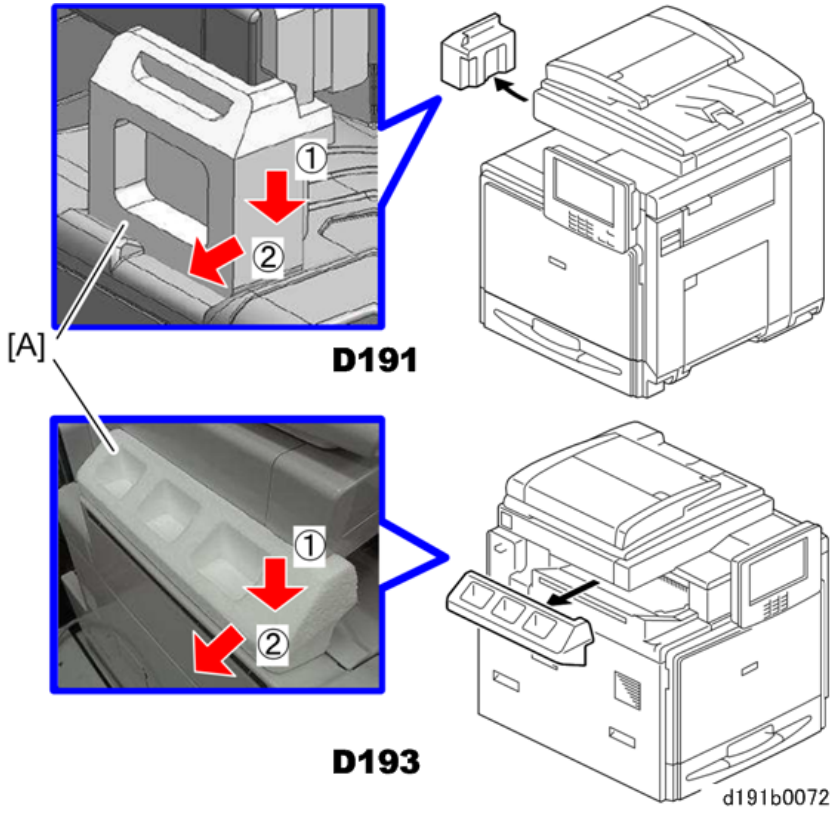

2. Push the retainer [A] down, and then pull it to the left.



d191b0004

3. Peel the film from the transparent cover of the ADF.



d191b0006

4. Remove the decal bag from the ADF and save it.
5. Remove all the tapes and material from the ADF.



d191b0002

6. Remove the tape and film [A] from the operation panel screen.
7. Remove the shipping cushion [B] from behind the operation panel.

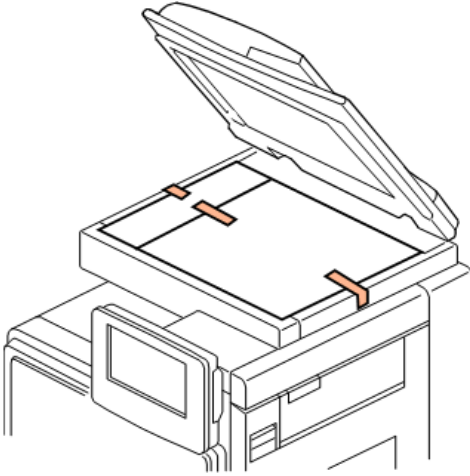

m022i102a

8. Open the ADF, and then remove all the retainers.

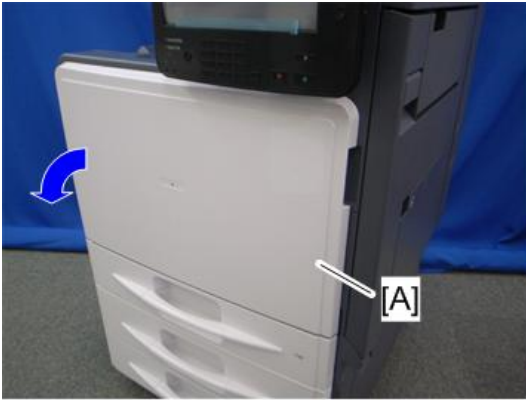

d191b0010

9. Open the front door [A].

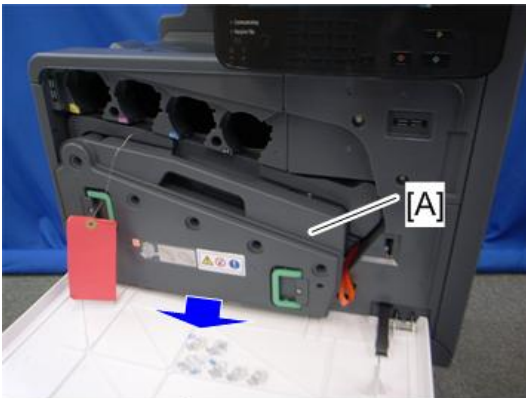

m022i504

10. Remove the waste toner bottle [A].



2

11. Remove the long screw.

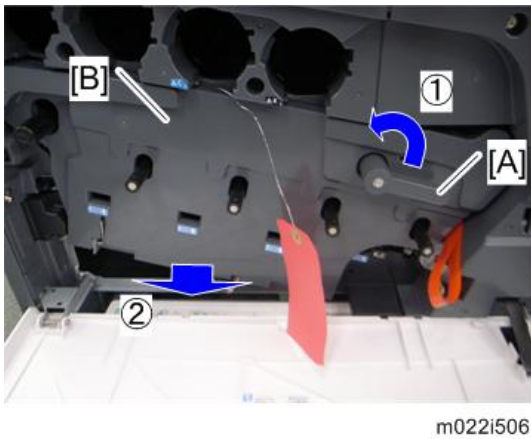

12. Turn the lock lever [A] counterclockwise, and then open the drum securing plate [B].

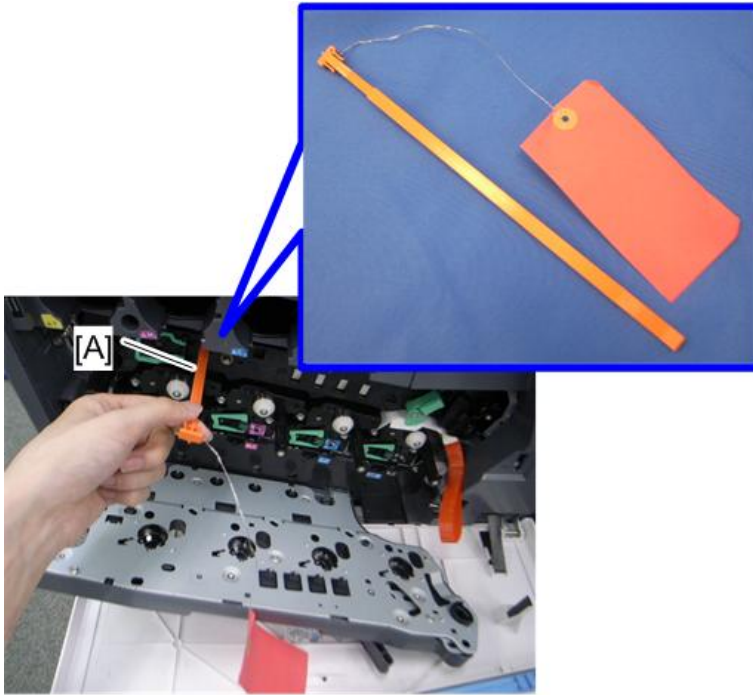

m022i507

13. Pull out the securing pin [A].

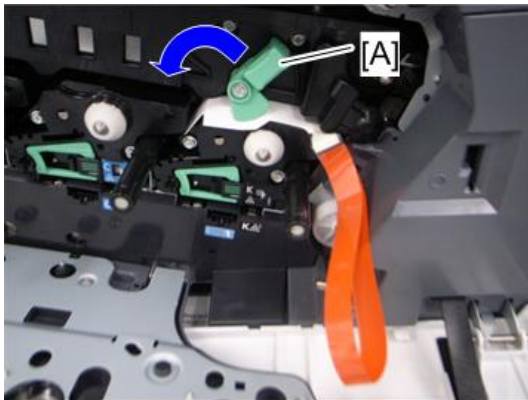

m022i509

14. Turn the ITB lock lever [A] counterclockwise.

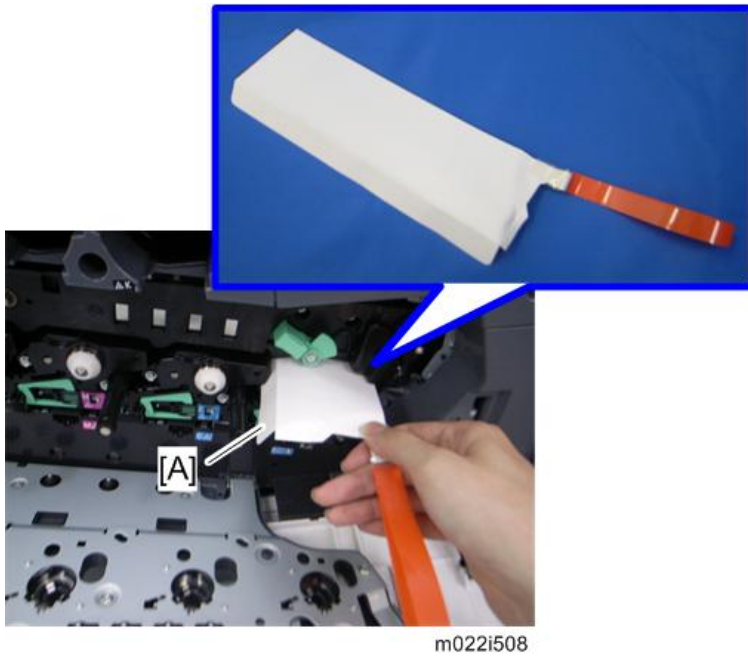

m022i508

15. Pull out the sheet of paper [A].

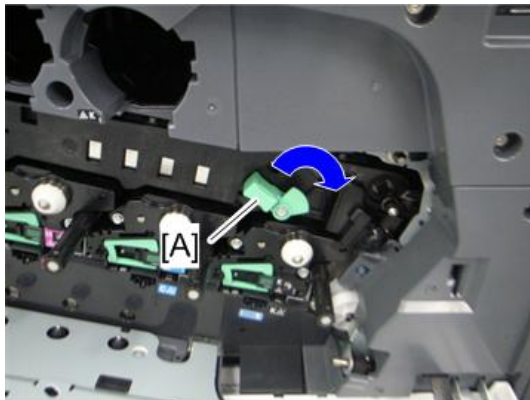

m022i510

16. Turn the ITB lock lever [A] clockwise.
17. Close the drum securing plate (🔩 x 1).
18. Attach the waste toner bottle.

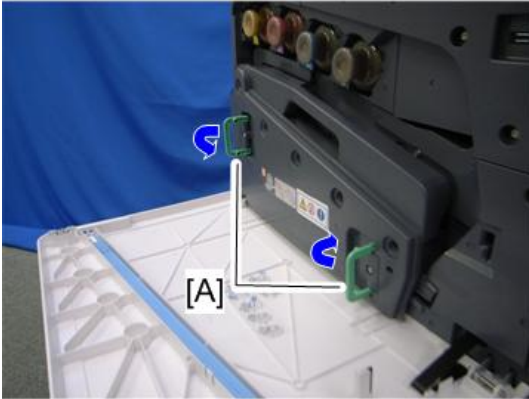

m022r503c

19. Close the handles [A].

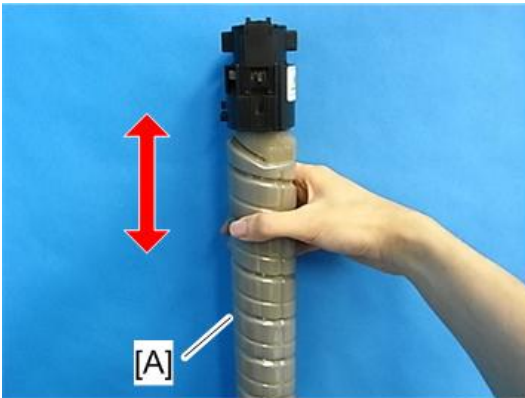

m022i511

20. Shake each toner bottle [A] five or six times.



m022i513

21. Install each toner bottle [A] in the machine.

22. Close the front door.

23. Connect the power cord to the machine.

Paper Tray

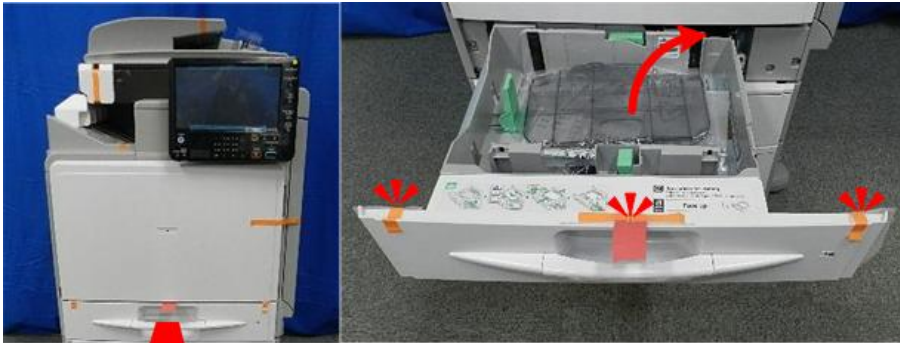

d191b0003

1. Pull out the paper tray.
2. Remove all tape and the tag from the front cover, and then remove the accessories inside the tray (power cord, decals, etc.)
3. Adjust the side guides and end guide for the size of the paper.

↓ Note

- Pull out the tray completely so you can adjust the side guides.
- Be sure to push down the green lock at the back of the tray to lock the guides in place.

Decals



d191b0061

1. Remove decals from the bag that you removed from the top of the ADF.



d191b0060

2. Attach the emblem decal [A] to the front door of the machine, if the emblem decal is not attached.
3. Attach the correct paper tray number and size decals to the paper trays.

Note

- Paper tray number and size decals are also used for the optional paper tray. Keep these decals for use with these optional units.

Left Tray Setting for D193

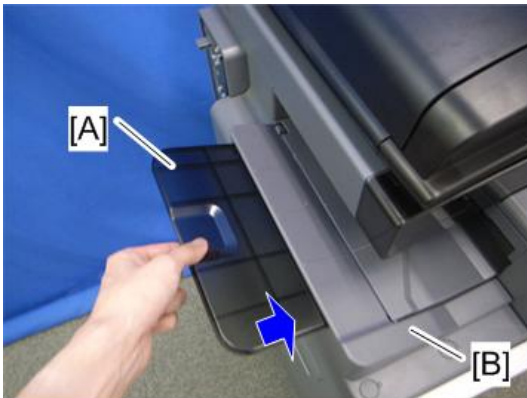

m022i514

For the finisher version of the machine (D193), set the left tray [A] in the internal finisher [B].

Initialize the Developer

1. Plug in the machine.

2. Make sure that the platen or ARDF is closed and the main power is turned off.
3. Turn the main power switch on. The machine automatically starts the initialization procedure. The LED turns blue when this procedure has finished.
4. Make copies of image samples (text, photo, and text/photo modes).
5. Do the Automatic Color Calibration process (ACC) for each mode (Copy mode, Printer 600 x 600 dpi, Printer 900 x 600 dpi, Printer 1800 x 600 dpi, and Printer 1200 x 1200 dpi) as follows:
 - 1) Print the ACC test pattern (User tools > Maintenance > Printer Function > Execute > Print).
 - 2) Put the printout on the exposure glass.
 - 3) Put 10 sheets of white paper on top of the test chart.
 - 4) Close the ARDF or the platen cover.
 - 5) Press "Scan" on the LCD panel. The machine starts the ACC.
6. Check that the sample image has been copied normally.
7. Do the user's color registration procedure (press Color Registration on the display panel).

Settings Relevant to the Service Contract

Change the necessary settings for the following SP modes if the customer has made a service contract.

↓ Note

- You must select one of the counter methods (developments/prints) in accordance with the contract (SP5045-001).

Counting method		
SP No.	Function	Default
SP5-045-001	Specifies if the counting method used in meter charge mode is based on developments or prints. NOTE: You can set this one time only. You cannot change the setting after you have set it for the first time.	"0": Developments
Service Tel. No. Setting		
SP No.	Function	Default
SP5-812-001 through 004	5812-002 programs the service station fax number. The number is printed on the counter list when the meter charge mode is selected. This lets the user fax the counter data to the service station.	-

Settings for @Remote Service

Note

- Prepare and check the following check points before you visit the customer site. For details, ask the @Remote key person.

Check points before making @Remote settings

1. The setting of SP5816-201 in the mainframe must be "0".
2. Print the SMC with SP5990-002 and then check if a device ID2 (SP5811-003) must be correctly programmed.
 - 6 spaces must be put between the 3-digit prefix and the following 8-digit number (e.g. xxx____xxx).
xxx____xxxxxxxx).
 - ID2 (SP5811-003) and the serial number (SP5811-001) must be the same (e.g. ID2: A01____23456789 = serial No. A0123456789)
3. The following settings must be correctly programmed.
 - Proxy server IP address (SP5816-063)
 - Proxy server Port number (SP5816-064)
 - Proxy User ID (SP5816-065)
 - Proxy Password (SP5816-066)

4. Get a Request Number

Execute the @Remote Settings

1. Enter the SP mode.
2. Input the Request number which you have obtained from @Remote Center GUI, and then enter [OK] with **SP5816-202**.
3. Confirm the Request number, and then click [EXECUTE] with **SP5816-203**.
4. Check the confirmation result with **SP5816-204**.

Value	Meaning	Solution/ Workaround
0	Succeeded	-
1	Request number error	Check the request number again.
3	Communication error (proxy enabled)	Check the network condition.
4	Communication error (proxy disabled)	Check the network condition.
5	Proxy error (Illegal user name or password)	Check Proxy user name and password.

Value	Meaning	Solution/ Workaround
6	Communication error	Check the network condition.
8	Other error	See "SP5816-208 Error Codes" below this.
9	Request number confirmation executing	Processing... Please wait.

5. Make sure that the screen displays the Location Information with **SP5816-205** only when it has been input at the Center GUI.
6. Click [EXECUTE] to execute the registration with **SP5816-206**.
7. Check the registration result with **SP5816-207**.

Value	Meaning	Solution/ Workaround
0	Succeeded	-
1	Request number error	Check the request number again.
2	Already registered	Check the registration status.
3	Communication error (proxy enabled)	Check the network condition.
4	Communication error (proxy disabled)	Check the network condition.
5	Proxy error (Illegal user name or password)	Check Proxy user name and password.
8	Other error	See "SP5816-208 Error Codes" below this.
9	Request number confirmation executing	Processing... Please wait.

8. Exit the SP mode.

SP5816-208 Error Codes

Cause	Code	Meaning	Solution/ Workaround
Operation Error, Incorrect Setting	-12002	Inquiry, registration attempted without acquiring Request No.	Obtain a Request Number before attempting the Inquiry or Registration.
	-12003	Attempted registration without execution of a confirmation and no previous registration.	Perform Confirmation before attempting the Registration.
	-12004	Attempted setting with illegal entries for certification and ID2.	Check ID2 of the mainframe.
	-12005	@Remote communication is prohibited. The device has an Embedded RC gate-related problem.	Make sure that "Remote Service" in User Tools is set to "Do not prohibit".
	-12006	A confirmation request was made after the confirmation had been already completed.	Execute registration.
	-12007	The request number used at registration was different from the one used at confirmation.	Check Request No.
	-12008	Update certification failed because mainframe was in use.	Check the mainframe condition. If the mainframe is in use, try again later.

Cause	Code	Meaning	Solution/ Workaround
Error Caused by Response from GW URL	-2385	Other error	
	-2387	Not supported at the Service Center	
	-2389	Database out of service	
	-2390	Program out of service	
	-2391	Two registrations for the same mainframe	Check the registration condition of the mainframe
	-2392	Parameter error	
	-2393	External RCG not managed	
	-2394	Mainframe not managed	
	-2395	Box ID for external RCG is illegal.	
	-2396	Mainframe ID for external RCG is illegal.	
	-2397	Incorrect ID2 format	Check the ID2 of the mainframe.
	-2398	Incorrect request number format	Check the Request No.

Security Function Installation

★ Important

- If the "Enhanced Security HDD Option Type M10" is installed at the same time of the main machine's installation, do not execute these settings described below. When the "Enhanced Security HDD Option Type M10" and security functions (Data Overwrite Security and HDD Encryption Unit) are activated in the same machine, the function of the "Enhanced Security HDD Option" is not guaranteed.

The machine contains the Security functions (Data Overwrite Security and HDD Encryption Unit) built into the controller board.

If you are installing a new machine, it is recommended to activate the Data Overwrite Security and HDD Encryption unit by selecting "Format All Data" from "System Settings" on the operation panel.

Note

- This method is recommended because there is no user data on the hard drive yet (Address Book data, image data, etc.).

If the customer wishes to activate the Data Overwrite Security and HDD Encryption unit on a machine that is already running, it is recommended to activate the unit by selecting "All Data" from "System Settings" on the operation panel.

Important

- **Selecting "All Data" will preserve the data that has already been saved to the hard drive. (If "Format All Data" is selected, all user data saved to the hard drive up to that point will be erased).**

Immediately after encryption is enabled, the encryption setting process will take several minutes to complete before you can begin using the machine.

Note

- If encryption is enabled after data has been stored on the disk, or of the encryption key is changed, this process can take up to three and a half hours or more.

The machine cannot be operated while data is being encrypted.

Once the encryption process begins, it cannot be stopped.

Make sure that the machine's main power is not turned off while the encryption process is in progress.

If the machine's main power is turned off while the encryption process is in progress, the hard disk will be damaged and all data on it will be unusable.

Print the encryption key and keep the encryption key (which is printed as a paper sheet).

Keep the encryption key in a safe place. If the encryption key is lost and is needed, the controller board, hard disk and NVRAM must all be replaced at the same time.

Note

- "NVRAM" mentioned in here means the NVRAM on the Controller Board.
- "NVRAM" or EEPROM on the BCU has nothing to do with this.

Please use the following procedure when the Data Overwrite Security and HDD Encryption is reinstalled.

Data Overwrite Security

Before You Begin the Procedure

1. Make sure that the following settings (1) to (3) are not at their factory default values.
 - (1) Supervisor login password
 - (2) Administrator login name
 - (3) Administrator login password

If any of these settings is at a factory default value, tell the customer these settings must be changed before you do the installation procedure.

2. Make sure that "Admin. Authentication" is on.

[System Settings] -> [Administrator Tools] -> [Administrator Authentication Management] -> [Admin. Authentication]

If this setting is off, tell the customer this setting must be on before you do the installation procedure.

3. Make sure that "Administrator Tools" is enabled (selected).

[System Settings] -> [Administrator Tools] -> [Administrator Authentication Management] -> [Available Settings]

If this setting is disabled (not selected), tell the customer this setting must be enabled (selected) before you do the installation procedure.



2

Installation Procedure

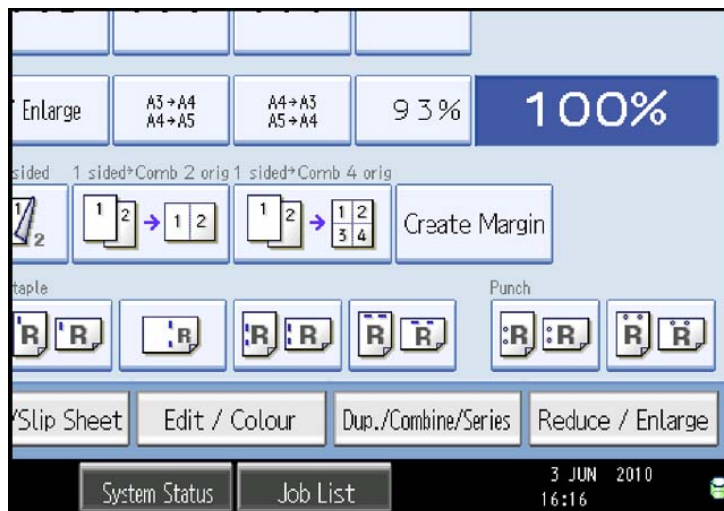
1. Connect the network cable if it needs to be connected.
2. Turn on the main power switch.
3. Go into the SP mode and push "EXECUTE" in SP5-878-001.
4. Exit the SP mode and turn off the operation switch. Then turn off the main power switch.
5. Turn on the machine power.
6. Do SP5-990-005 (SP print mode Diagnostic Report).
7. Go into the User Tools mode, and select [System Settings] [Administrator Tools] [Auto Erase Memory Setting] [On].
8. Exit the User Tools mode.



d1420091

	Icon [1]	This icon is lit when there is temporary data to be overwritten, and blinks during overwriting.
	Icon [2]	This icon is lit when there is no temporary data to be overwritten.

9. Check the display and make sure that the overwrite erase icon appears.
10. Check the overwrite erase icon.

The icon [1] is lit when there is temporary data to be overwritten, and blinks during overwriting.

The icon [2] is lit when there is no temporary data to be overwritten.

HDD Encryption

Before You Begin the Procedure:

1. Make sure that the following settings (1) to (3) are not at the factory default settings.

(1) Supervisor login password

(2) Administrator login name

(3) Administrator login password

These settings must be set up by the customer before the HDD Encryption unit can be installed.

2. Confirm that "Admin. Authentication" is on: [User tools/Counter] key -> [System Settings] -> [Administrator Tools] -> [Administrator Authentication Management] -> [Admin. Authentication] -> [On]

If this setting is off, tell the customer that this setting must be on before you can do the installation procedure.

3. Confirm that "Administrator Tools" is selected and enabled.

[User tools/Counter] key -> [System Settings] -> [Administrator Tools] -> [Administrator Authentication Management] -> [Available Settings]

"Available Settings" is not displayed until step 2 is done.

If this setting is not selected, tell the customer that this setting must be selected before you can do the installation procedure.

Installation Procedure:

1. Turn on the main power switch, and then enter the SP mode.
2. Select SP5878-002, and then press "Execute" on the LCD.
3. Exit the SP mode after "Completed" is displayed on the LCD.

4. Turn off the main power switch.

Enable Encryption Setting:

1. Press the [User tools/Counter] key.
2. Press [System Settings].
3. Press [Administrator Tools].
4. Press [Machine Data Encryption Settings]. If this item is not visible, press [Next] to display more settings.
5. Press [Encrypt].

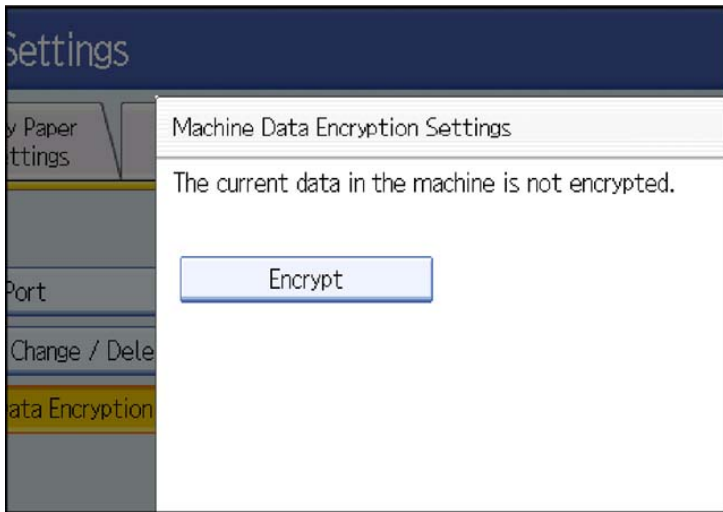

d1420092

6. Select the data to be carried over to the hard disk and not be reset.
To carry all of the data over to the hard disk, select [All Data].
To carry over only the machine settings data, select [File System Data Only].
To reset all of the data, select [Format All Data].

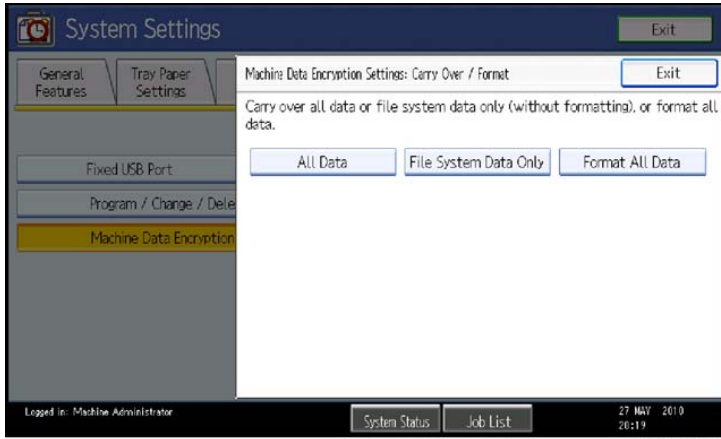

d1420093

- 7. The following message will be displayed. Press the [Start] key to print the encryption key for safe keeping.



d1420094

- 8. Press [Exit] to remove the following message.

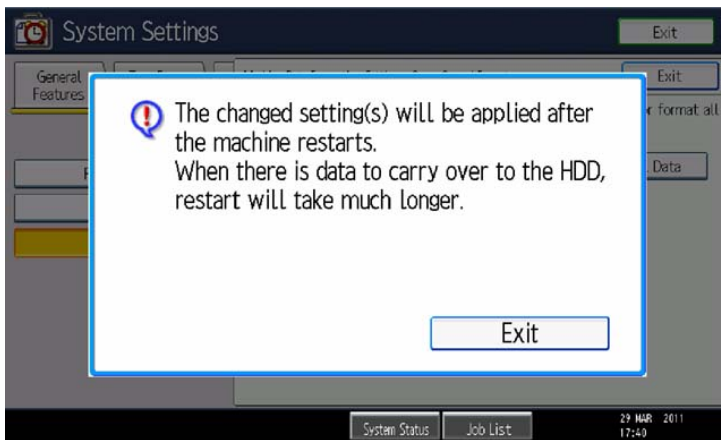

d1420095

9. Press [Exit] again.
10. Press the [User Tools/Counter] key.

★ Important

- After step 10, the initial operation display appears as below. However, HDD data encryption has not been completed at this moment. Step 11 and step 12 should be performed in order to encrypt the HDD data.

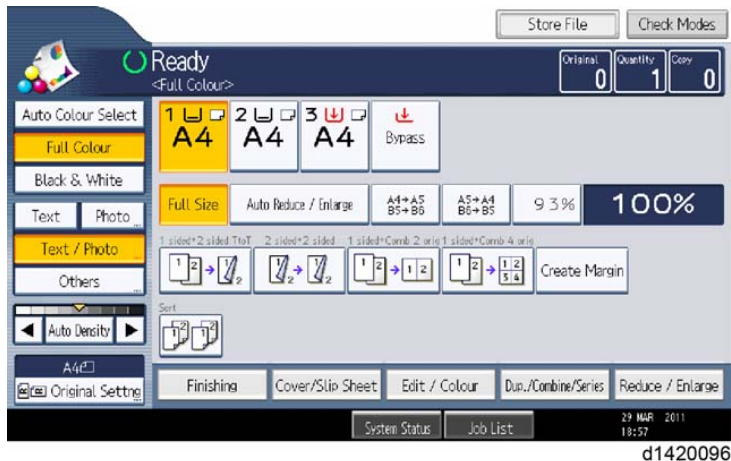

11. Turn the main power switch off and on.
12. "Memory Conversion complete. Turn the main power switch off" is displayed as below. Then turn the main power switch off and on.

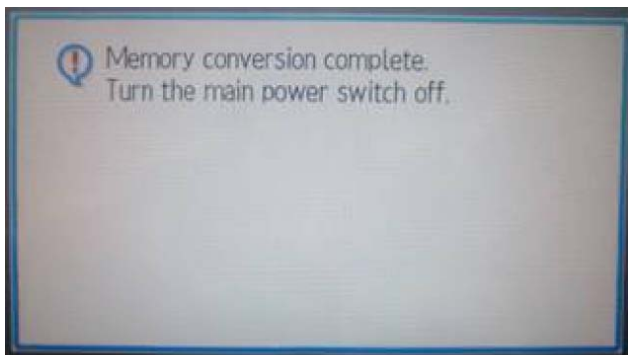

13. Then initial operation display appears again. After this step, HDD data encryption has already been completed.

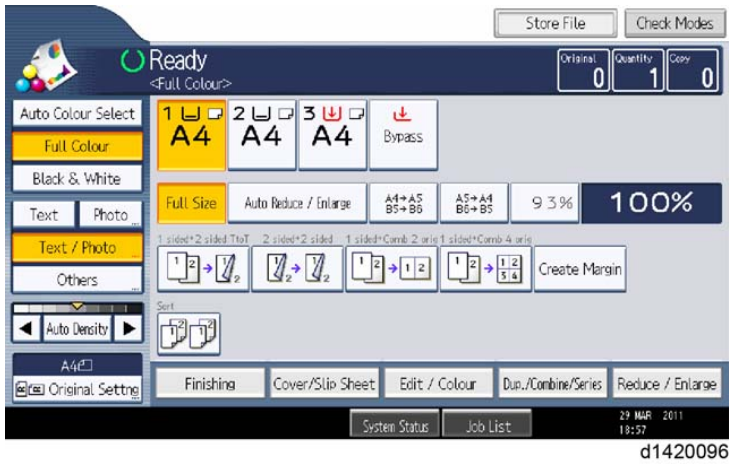

Check the Encryption Settings

1. Press the [User tools/Counter] key
2. Press [System Settings].
3. Press [Administrator Tools].

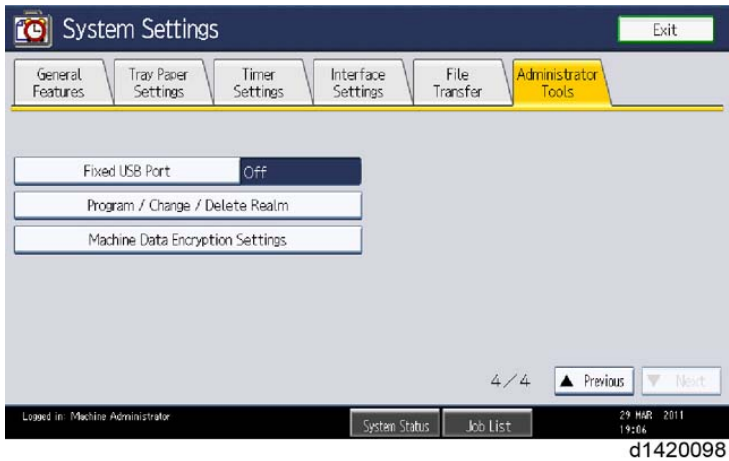

4. Press [Machine Data Encryption Settings].

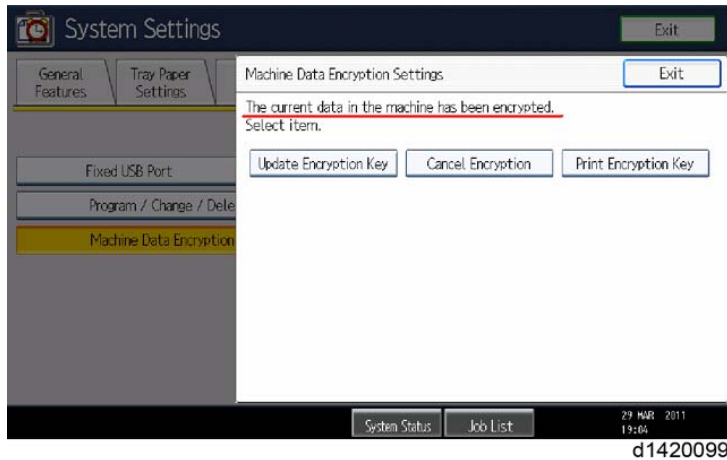

5. Please confirm whether the encryption has been completed or not on this display.

Print the encryption key

Use the following procedure to print the key again if it has been lost or misplaced.

1. Press the [User tools/Counter] key.
2. Press [System Settings].
3. Press [Administrator Tools].
4. Press [Machine Data Encryption Settings].
If this item is not visible, press [Next] to display more settings.
5. Press [Print Encryption Key].

Encryption key sample

Machine Data Encryption Key

This is an encryption key which allows you to protect confidential data stored in the machine.
 It is essential that the safekeeping and destruction of this encryption key be under your direct responsibility.
 Data saved and programmed on the machine (documents, image data, setting values, address book contents etc.) can be encrypted/decrypted with this encryption key.
 If this machine breaks down, saved and programmed data in the machine can only be restored by entering this encryption key.
 (Please note that it may not be possible to restore data in certain machine breakdown cases.)
 This machine data encryption key will remain valid as long as the encryption is not cancelled or the encryption key is not changed.
 After changing or cancelling the encryption key, please shred this document to destroy confidential data.

Output Date/Time:September 03,2010 08:55:25 AM
 Machine Type:Aficio MP C400SR
 Machine ID:S7500717004
 Machine Data Encryption Key:
6pFIFFGH#EBiYkPafBJz6YE\$wYXk

d1420100

The encryption key is printed out as a sheet of paper like the example shown above.
 Please instruct the customer to keep it in a safe place.

When the data overwrite security and encryption functions cause a problem

This section explains troubleshooting for the following symptoms:

- SC 861 to 865 (defective HDD)
- Any SC that indicates a defective controller board
- "Please wait" remains on the display

Test the machine using this flow chart, to determine which parts are causing the problem:

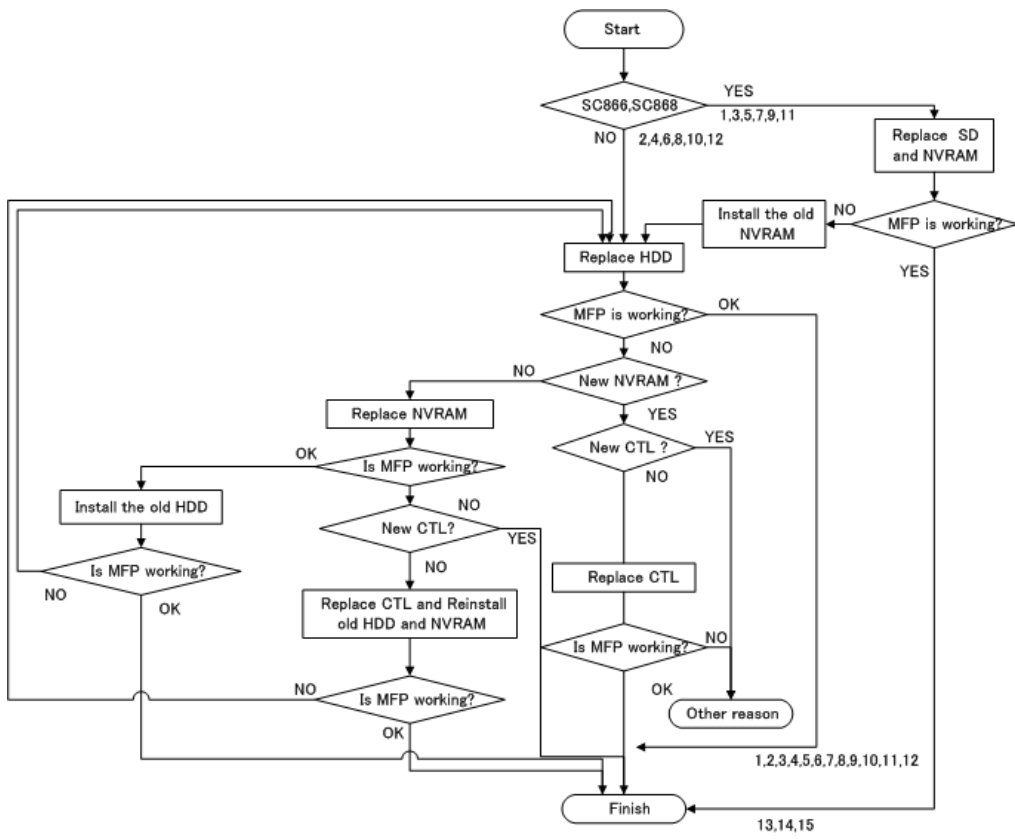

m022i542

The following table shows what to do in each case:

For example, if only the controller and HDD were found to be defective, then it is case 4 in the table below.

Encryption OFF:

CTL	HDD	NVRAM	Action	No
X	X	X	Replace CTL/ HDD/ / NVRAM	1
X	X	X	Replace CTL/ HDD/ NVRAM	2
X	X	(X)	Replace CTL/ HDD/ NVRAM	3
X	X	O	Replace CTL/ HDD	4
X	O	X	Replace CTL/ NVRAM	5
X	O	X	Replace CTL/ NVRAM	6
X	O	(X)	Replace CTL/ NVRAM	7

X	O	O	Replace CTL	8
O	X	X	Replace CTL/ NVRAM	9
O	X	X	Replace CTL/ NVRAM	10
O	X	(X)	Replace CTL/ NVRAM	11
O	X	O	Replace HDD	12
O	O	X	Replace NVRAM	13
O	O	X	Replace NVRAM	14
O	O	(X)	Replace NVRAM	15

Encryption ON:

CTL	HDD	NVRAM	Action	No
X	X	X	Replace CTL/ HDD/ NVRAM	1
X	X	X	Replace CTL/ HDD/ NVRAM	2
X	X	(X)	Replace CTL/ HDD/ NVRAM	3
X	O	O	Replace CTL/ HDD	4
X	O	X	Replace CTL/ NVRAM, then the HDD is automatically formatted	5
X	O	X	Replace CTL/ NVRAM, then the HDD is automatically formatted	6
X	O	(X)	Replace CTL, then restore the old encryption key, then replace NVRAM.	7
X	X	O	Replace CTL, then restore the old encryption key.	8
O	X	X	Replace HDD/ NVRAM	9
O	X	X	Replace HDD/ NVRAM	10
O	X	(X)	Replace HDD/ NVRAM	11
O	X	O	Replace HDD	12
O	O	X	Replace NVRAM	13

○	○	X	Replace NVRAM	14
○	○	(X)	Replace NVRAM	15

○: Not defective parts

X: Defective parts, must replace

(X): Not defective parts but must be replaced

If the controller board is replaced, the NVRAM must be replaced.

If the NVRAM is replaced, the controller board must be replaced.

Moving the Machine

This section shows you how to manually move the machine. See the section "Transporting the Machine" if you have to pack the machine and move it a longer distance.

- Remove all trays from the optional paper feed unit.

Transporting the Machine

Main Frame

1. Do SP 4806-001 to move the scanner carriage from the home position. This prevents dust from falling into the machine during transportation.
2. Make sure there is no paper left in the paper trays. Then fix down the bottom plates with a sheet of paper and tape.
3. Do one of the following:
 - Attach shipping tape to the covers and doors.
 - Shrink-wrap the machine tightly.

↓ Note

- After you move the machine, Make sure you do the "Forced Line Position Adjustment" as follows. This optimizes color registration.
- Do the "Forced Line Position Adj. Mode c" (SP2-111-3).
- Then do the "Forced Line Position Adj. Mode a" (SP2-111-1).
To check if SP 2-111-1 was successful, watch the screen during the process. A message is displayed at the end. Also, you can check the result with SP 2-194-10 to -12.
- Make sure that the side fences in the trays are correctly positioned to prevent color registration errors.

Paper Feed Unit (M368)

Component Check

Check the quantity and condition of the accessories against the following list.

No.	Description	Q'ty
1	Screw (M3 x 6)	6
2	Screw (M4 x 10)	2
3	Spring washer screw	1
4	Securing bracket	2
5	Caster stand	6
6	Stand cover	6

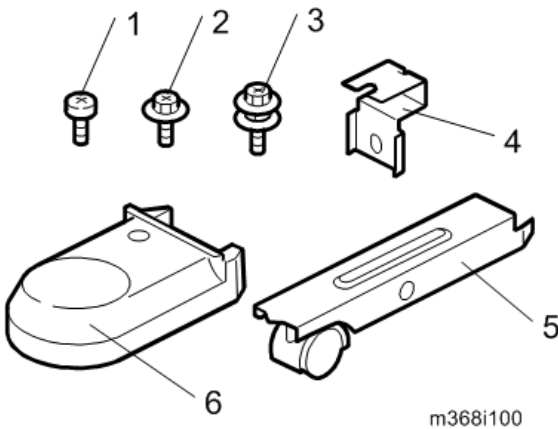

Installation Procedure

⚠ CAUTION

- Unplug the machine power cord before starting the following procedure.
- The handles of the main machine for lifting must be inserted inside the machine and locked, unless these handles are used for the installation or relocation of the main machine.
- You need two or more persons to lift the copier. The copier is highly unstable when lifted by one person, and may cause human injury or property damage.

For installing the paper feed unit (M368) only

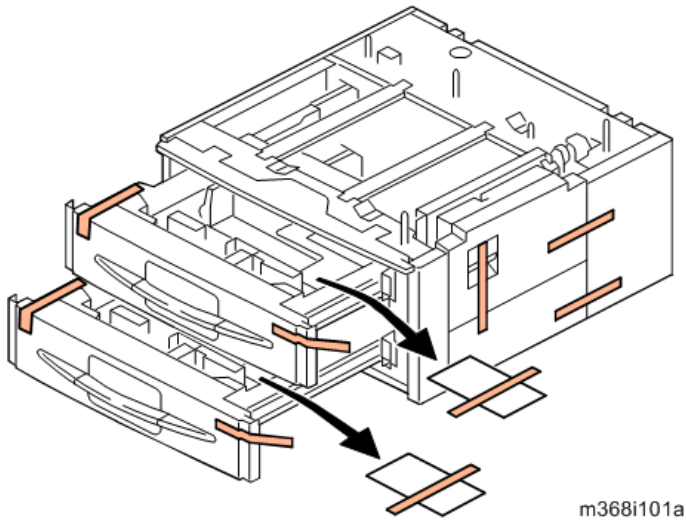

1. Remove all tapes on the paper feed unit.
2. Remove the paper tray and remove all tapes and padding.
3. Lift the copier and install it on the paper feed unit.

Note

- Hold the handle and grips of the machine when you lift and move the machine.

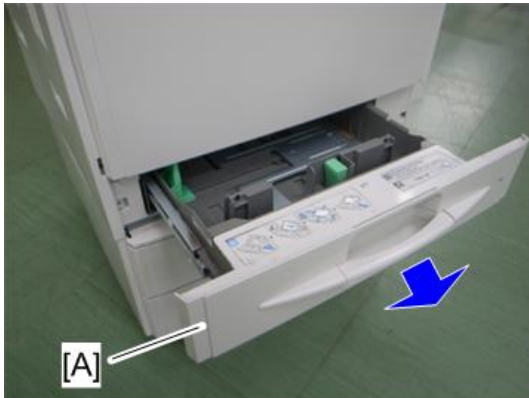

4. Remove the paper tray [A] of the machine.



5. Attach a screw (spring washer screw), using a securing bracket [A] to tighten the screw.

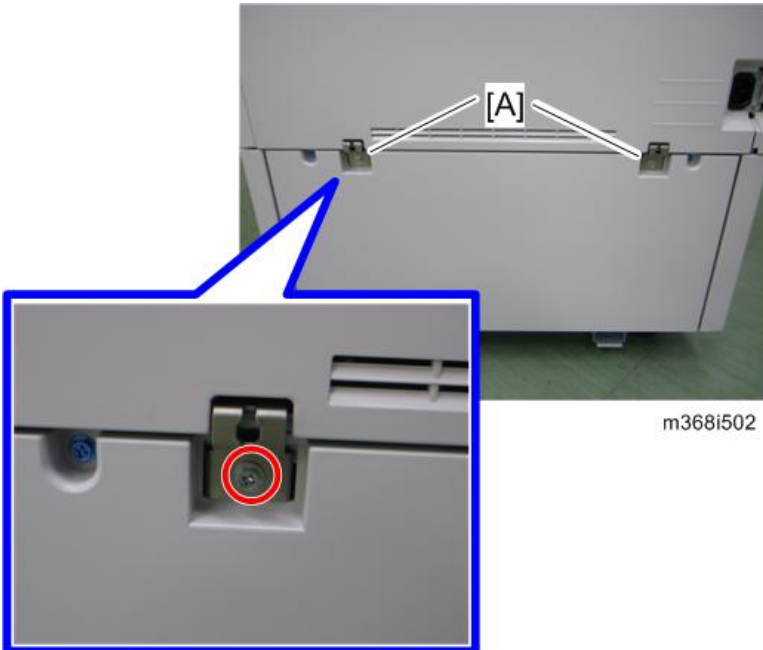

6. Attach a securing bracket [A] to each side of the paper tray unit, as shown (🔩 x 1: M4 x 10 each).

7. Reinstall the paper tray.

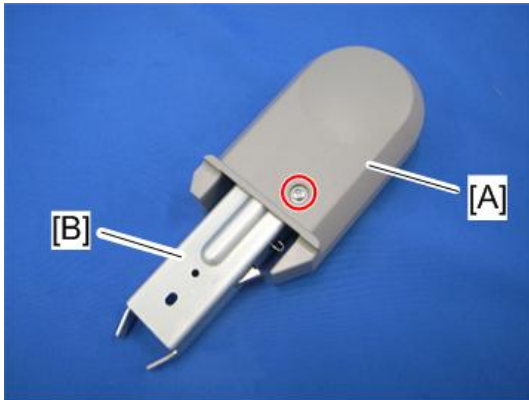

m368i504

8. Attach the stand covers [A] to the caster stands [B].

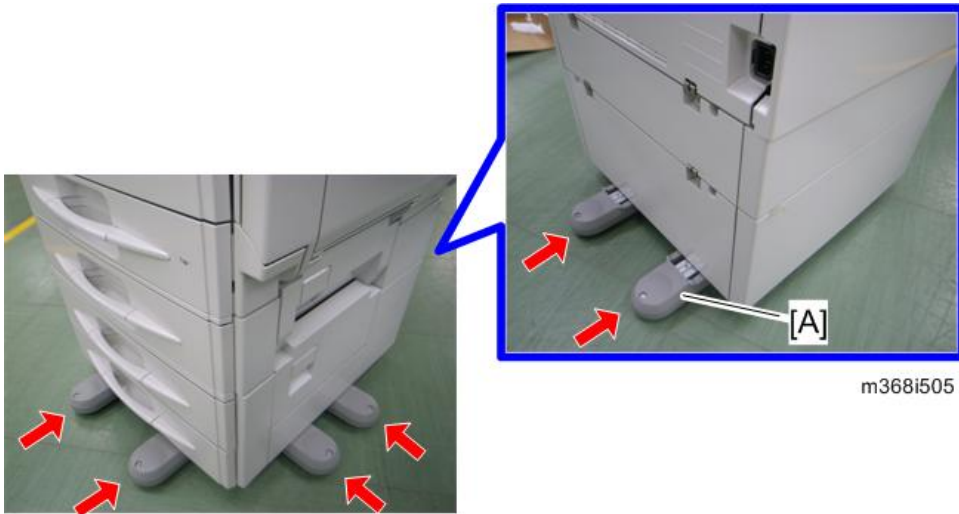

m368i505

9. Attach the caster stands [A].
10. Load paper into the paper feed unit.
11. Turn on the main power switch of the machine.
12. Adjust the registration for each tray (see page 198).
 - For tray 2, use SP1002-003
 - For tray 3, use SP1002-004
13. Check the paper feed unit operation and copy quality.

For installing with the paper feed unit (M367)

1. Remove the strips of tape.

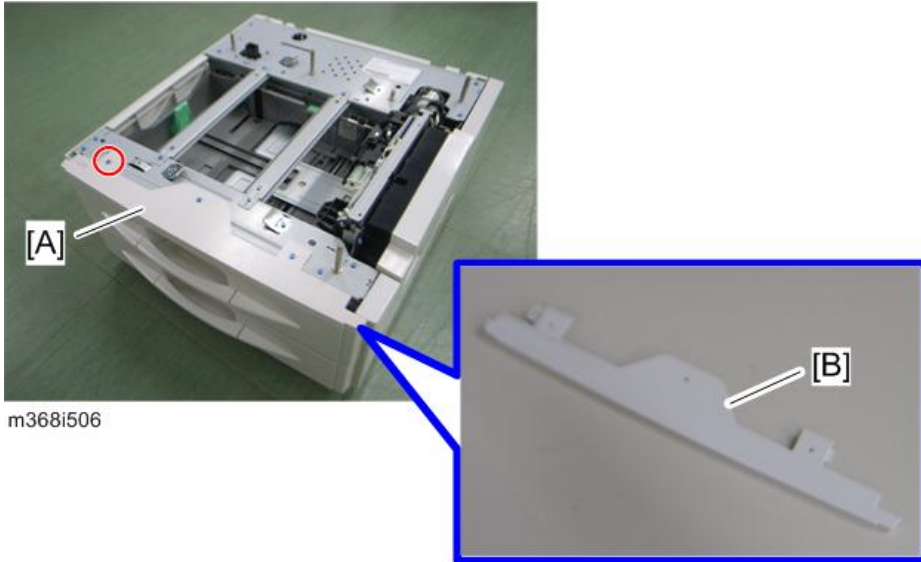

m368i506

2. Replace the upper front cover [A] with another cover [B] (provided with the M367) (1 x 1).

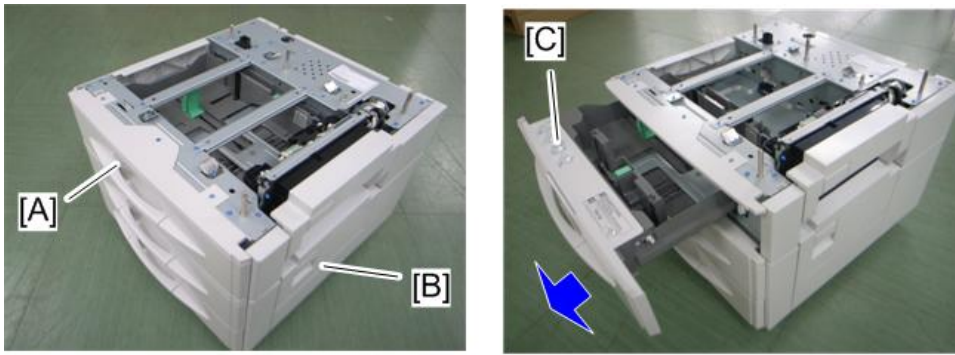

m367i505

3. Lift the M367 [A] and install it on the M368 [B].

4. Remove the paper tray [C] (for M367).

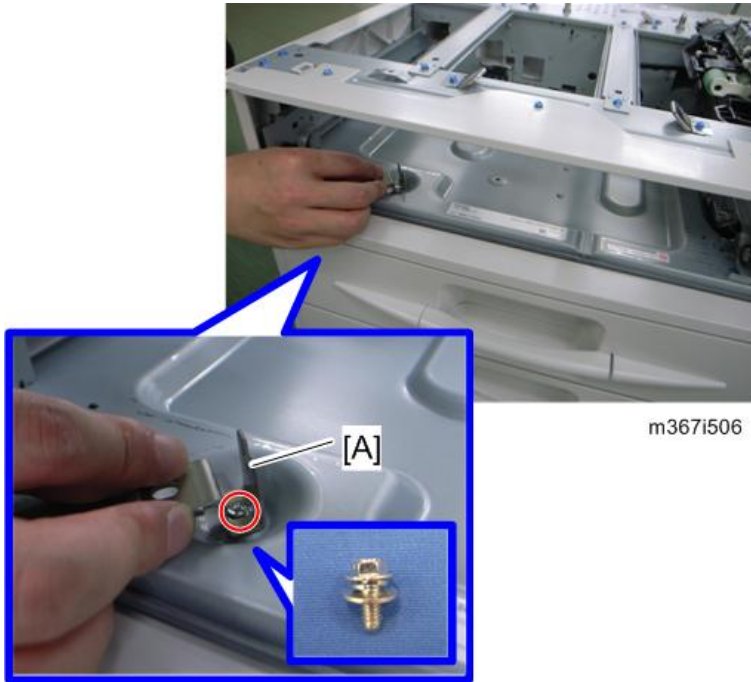

5. Attach a screw (spring washer screw), using a securing bracket [A] to tighten the screw.

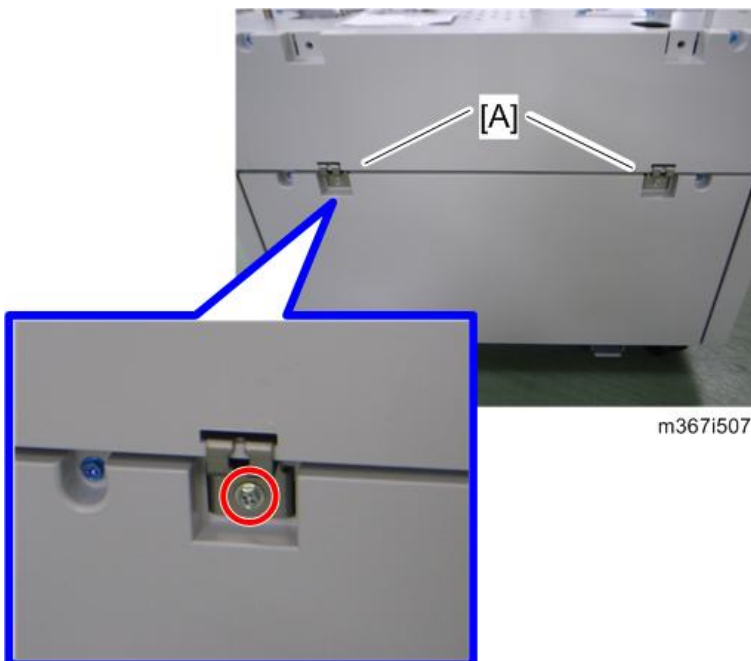

6. Attach a securing bracket [A] to each side of the paper tray unit, as shown (x 1: M4 x 10 each).
7. Reinstall the paper tray.
8. Lift the copier and install it on the paper feed unit.

Note

- Hold the handle and grips of the machine when you lift and move the machine.

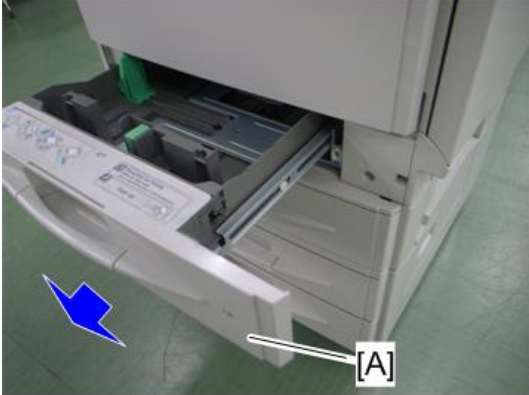

m367i508

9. Remove the paper tray [A] of the machine.



m367i509

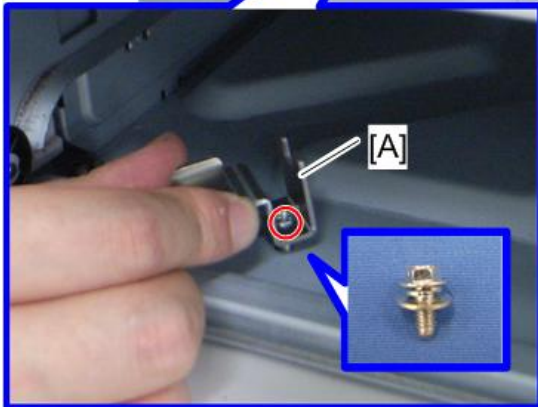

10. Attach a screw (spring washer screw), using a securing bracket [A] to tighten the screw.

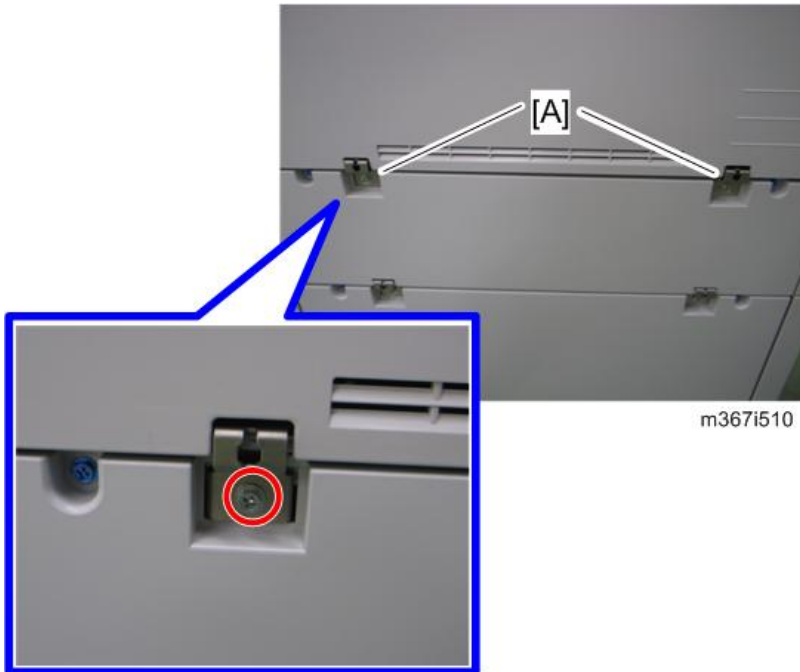

11. Attach a securing bracket [A] to each side of the paper tray unit, as shown (x 1: M4 x 10 each).
12. Reinstall the paper tray.

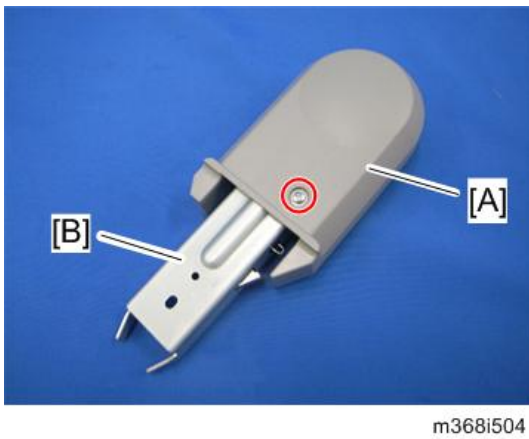

13. Attach the stand covers [A] to the caster stands [B].

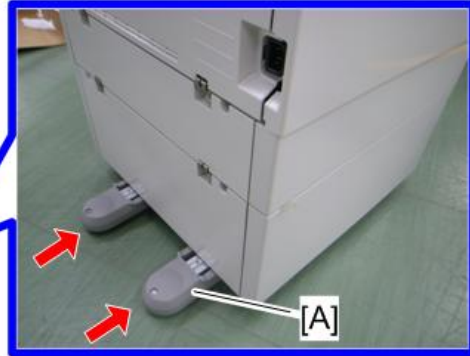

m368i505

14. Attach the caster stands [A].
15. Load paper into the paper feed unit.
16. Turn on the main power switch of the machine.
17. Adjust the registration for each tray (see page 198).
 - For tray 2, use SP1002-003
 - For tray 3, use SP1002-004
 - For tray 4, use SP1002-005
18. Check the paper feed unit operation and copy quality.

Paper Feed Unit (M367)

Component Check

Check the quantity and condition of the accessories against the following list.

No.	Description	Q'ty
1	Upper front cover	1
2	Screw (M4 x 10)	2
3	Spring washer screw	1
4	Securing bracket	2

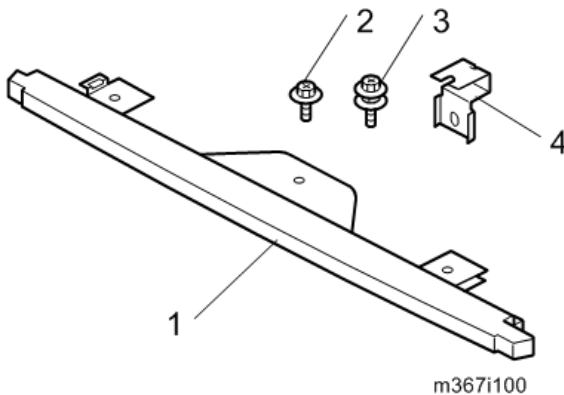

Installation Procedure

⚠ CAUTION

- Turn off the main switch of the copier and unplug the power cord before you start the installation procedure.
- You need two or more persons to lift the copier. The copier is highly unstable when lifted by one person, and may cause human injury or property damage.
- Do not lift the copier with the paper feed unit installed. The handle and grips may be damaged.

For installing the paper feed unit (M367) only

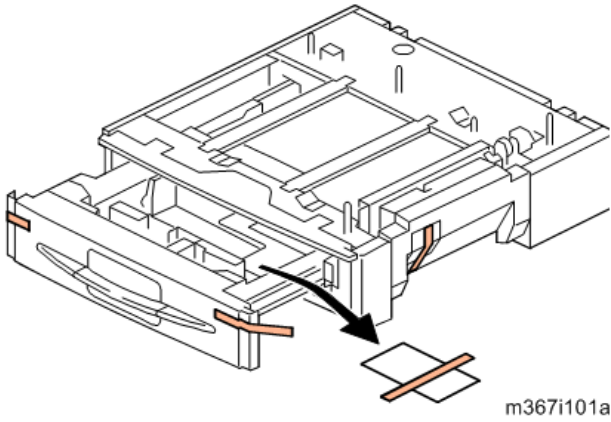

1. Remove all tapes on the paper feed unit.
2. Remove the paper tray and remove all tapes and padding.
3. Lift the copier and install it on the paper feed unit.

Note

- Hold the handle and grips of the machine when you lift and move the machine.

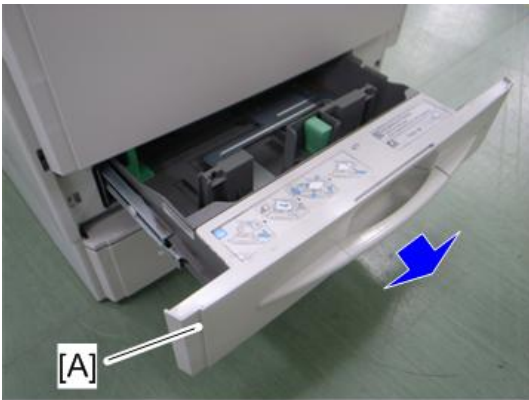

4. Remove the paper tray [A] of the machine.



5. Attach a screw (spring washer screw), using a securing bracket [A] to tighten the screw.

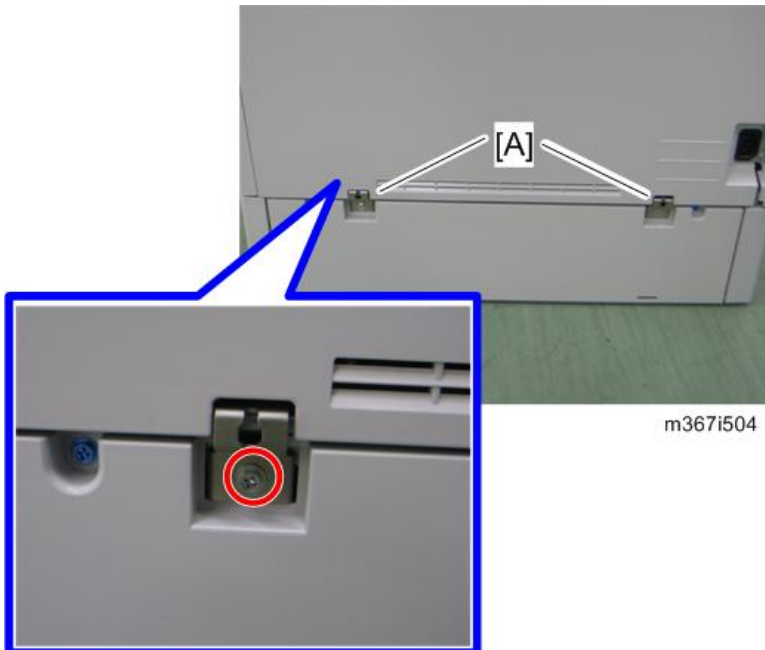

6. Attach a securing bracket [A] to each side of the paper tray unit, as shown (🔩 x 1: M4 x 10 each).
7. Reinstall the paper tray.

8. Load paper into the paper feed unit.
9. Turn on the main power switch of the machine.
10. Adjust the registration for each tray (☞ page 198).
 - Use SP1002-003
11. Check the paper feed unit operation and copy quality.

For installing with the paper feed unit (M368)

1. Remove the strips of tape.

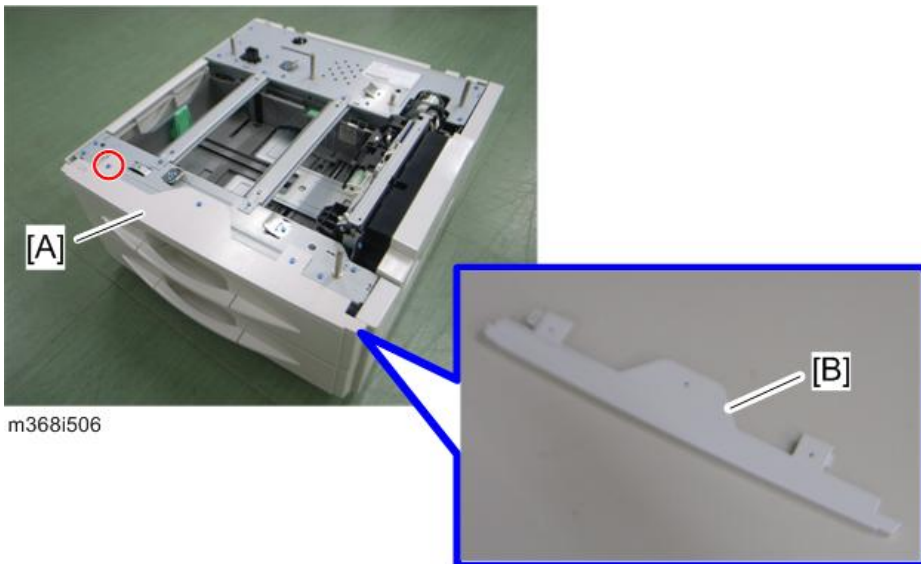

2. Replace the upper front cover [A] with another cover [B] (provided with the M368) (☞ x 1).

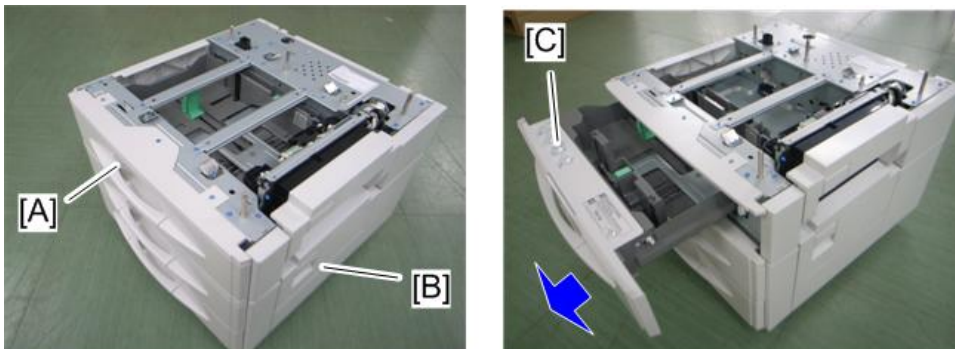

3. Lift the M367 [A] and install it on the M368 [B].
4. Remove the paper tray [C] (for M367).

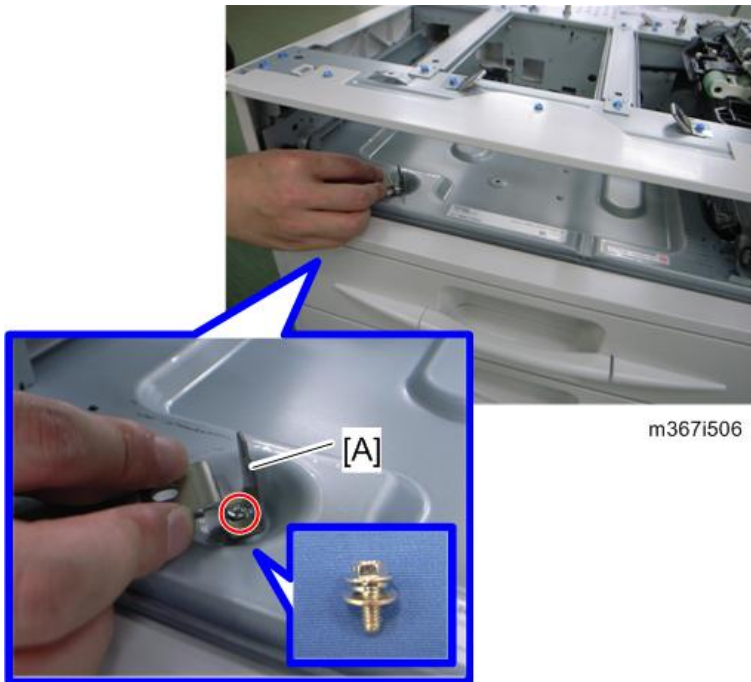

5. Attach a screw (spring washer screw), using a securing bracket [A] to tighten the screw.

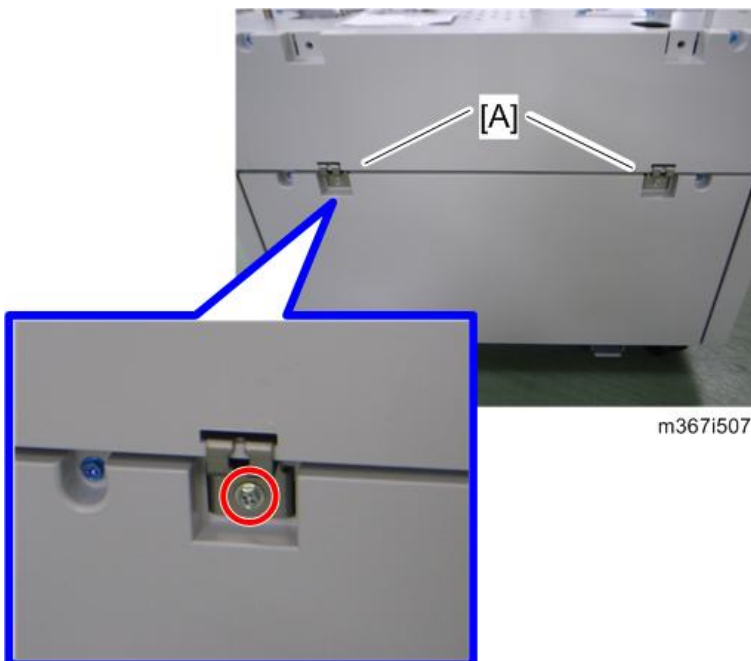

6. Attach a securing bracket [A] to each side of the paper tray unit, as shown (🔩 x 1: M4 x 10 each).
7. Reinstall the paper tray.
8. Lift the copier and install it on the paper feed unit.

Note

- Hold the handle and grips of the machine when you lift and move the machine.

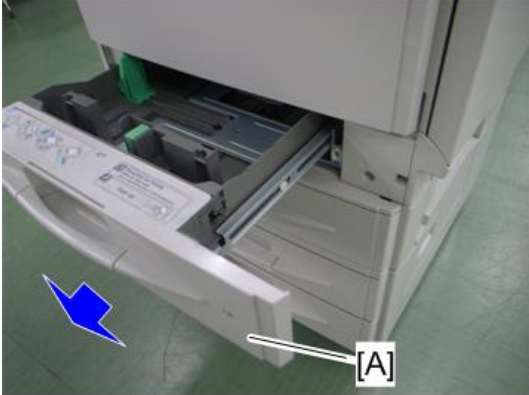

m367i508

9. Remove the paper tray [A] of the machine.



m367i509

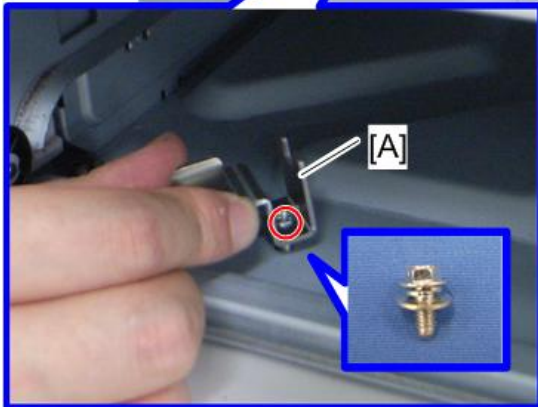

10. Attach a screw (spring washer screw), using a securing bracket [A] to tighten the screw.

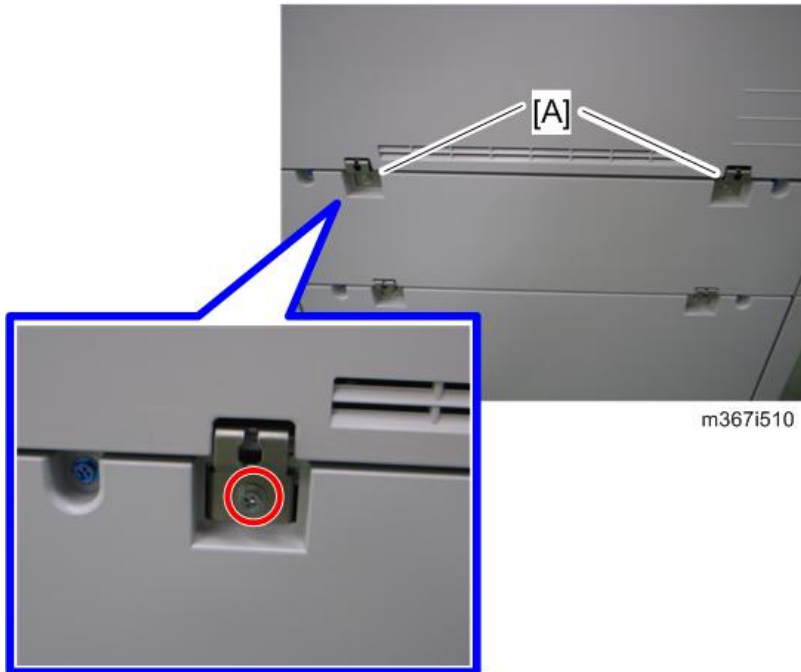

11. Attach a securing bracket [A] to each side of the paper tray unit, as shown (x 1: M4 x 10 each).
12. Reinstall the paper tray.

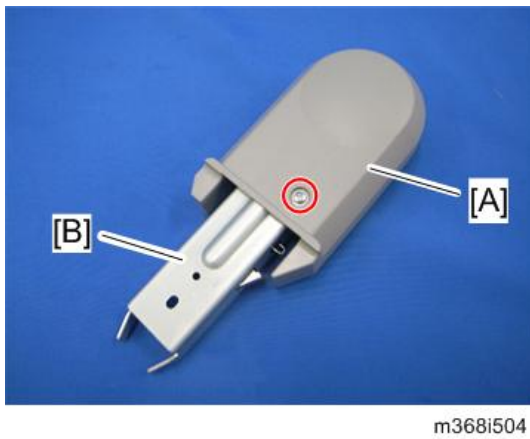

13. Attach the stand covers [A] to the caster stands [B].

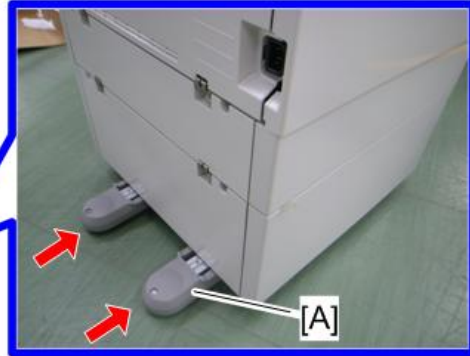

m368i505

14. Attach the caster stands [A].
15. Load paper into the paper feed unit.
16. Turn on the main power switch of the machine.
17. Adjust the registration for each tray (see page 198).
 - For tray 2, use SP1002-003
 - For tray 3, use SP1002-004
 - For tray 4, use SP1002-005
18. Check the paper feed unit operation and copy quality.

Side Tray (M369)

Component Check

Check the quantity and condition of the components against the following list.

No.	Description	Q'ty
1.	Side Tray Paper Exit Unit	1
2.	Side Tray	1
3.	Inner Cover	1
4.	Screw: M4x8	2
5.	Cap	2

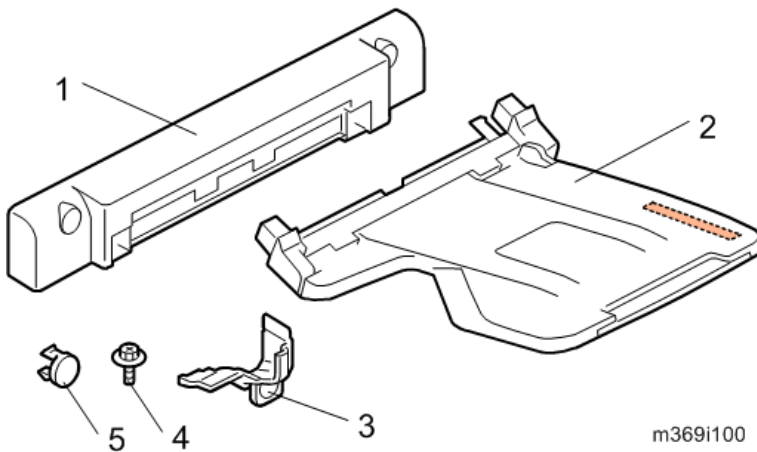

Installation Procedure

⚠ CAUTION

- Unplug the copier power cord before starting the following procedure.

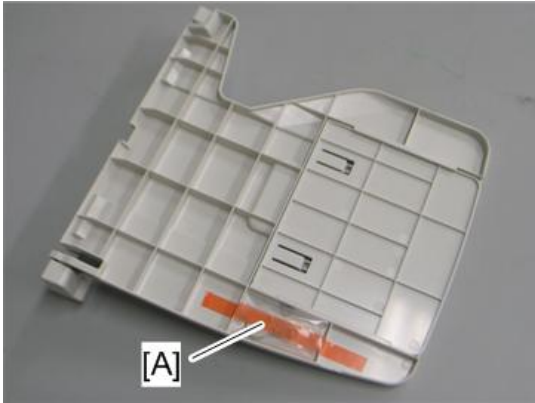

m369i501

1. Remove the tape [A] on the side tray.

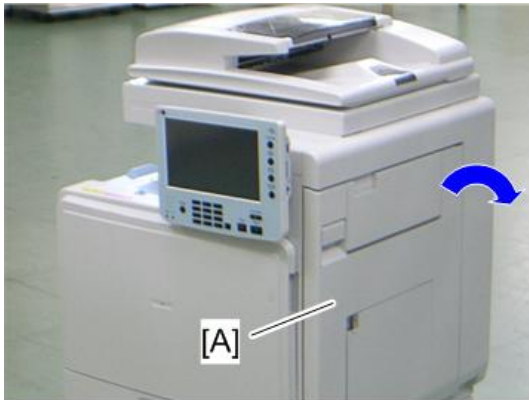

m369i507

2. Open the duplex unit [A].

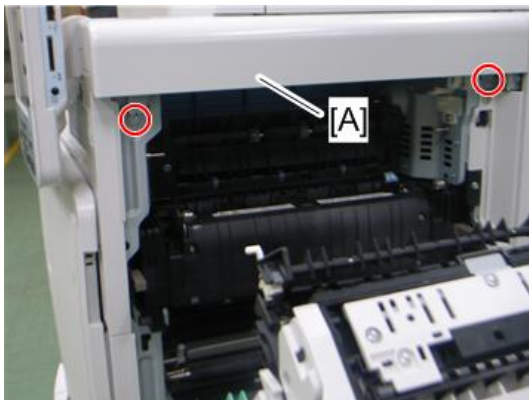

m369i503

3. Remove the right upper cover [A] (⚙️ x 2).

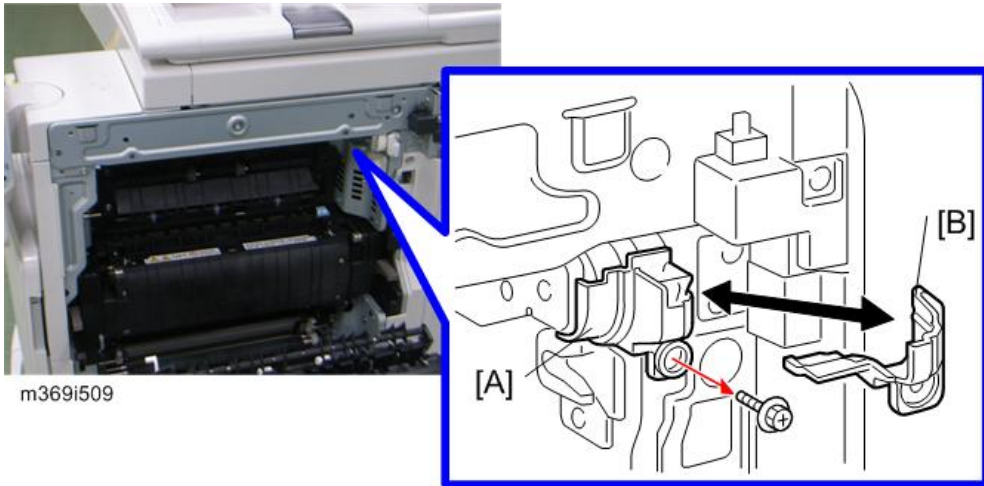

m369i509

4. Right upper inner cover [A] (🔩 x 1).
5. Attach the right upper inner cover [B] (provided with M369) (🔩 x 1: removed in step 4).

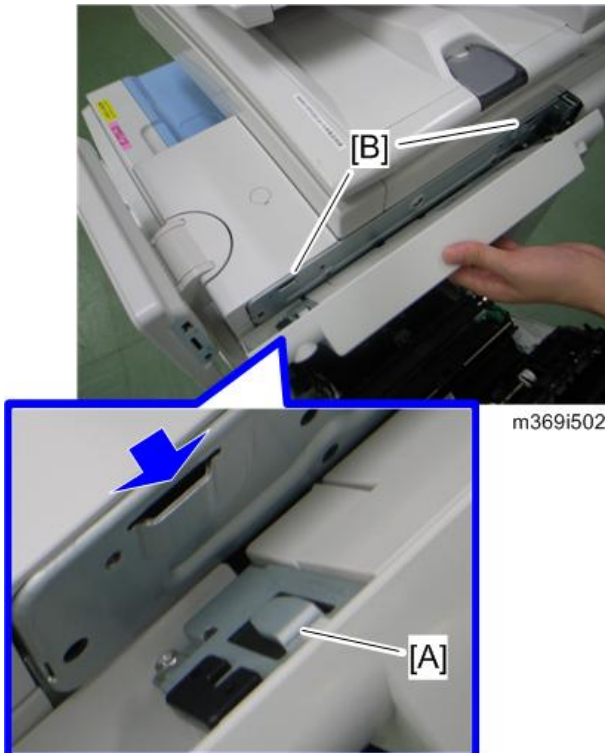

m369i502

6. Set the two hooks [A] into the holes [B] in the machine.

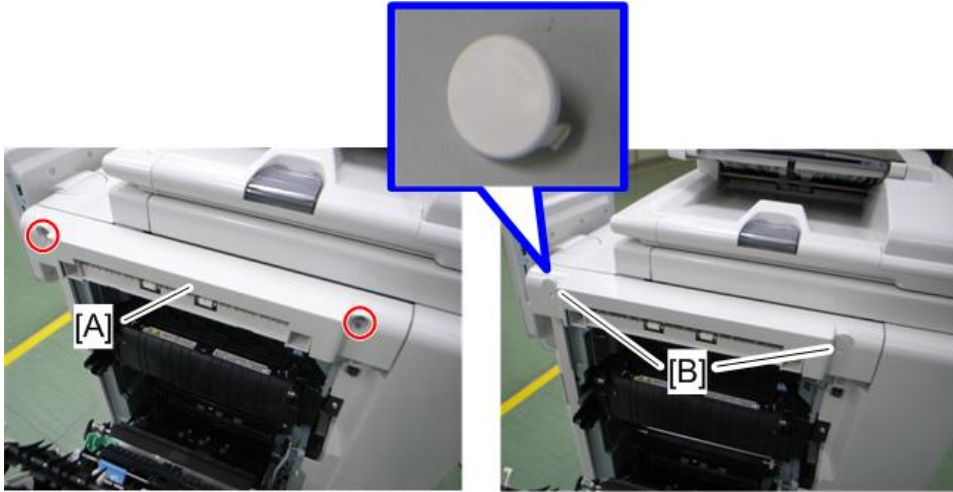

m369i504

- 7. Install the side tray paper exit unit [A] (1 x 2).
- 8. Attach the two caps [B].

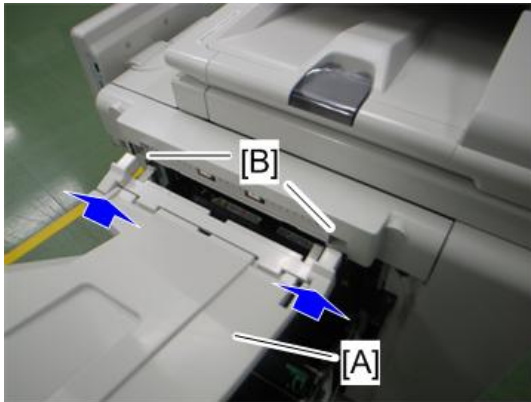

m369i505

- 9. Set the two tabs of the side tray [A] into the holes [B] in the machine.



m369i506

10. Close the duplex unit [A].
11. Turn on the main power switch of the machine.
12. Check the side tray operation.

1-Bin Tray Unit (M370)

Component Check

Check the quantity and condition of the components against the following list.

No.	Description	Q'ty
1	Tray	1
2	1-Bin Tray Unit	1
3	Bracket	1
4	Bind Screw (M3 x 6)	1
5	Screw (M3 x 8)	2
6	Harness clamp	3

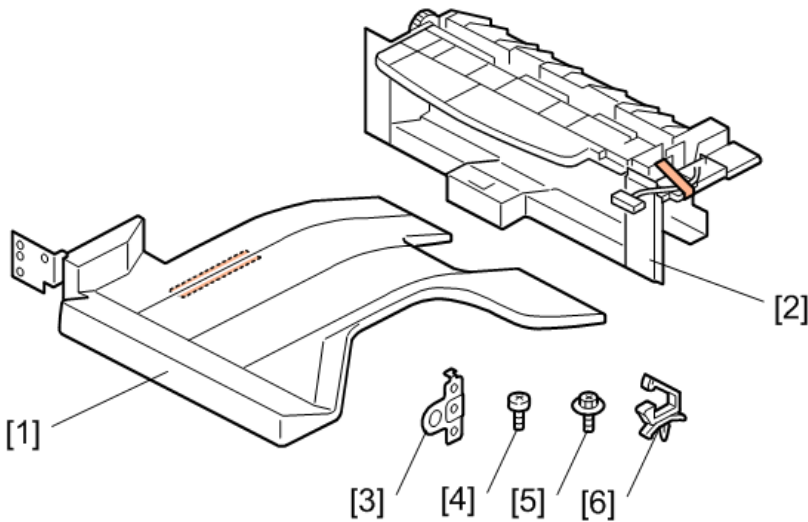

m370i100

Installation Procedure

⚠ CAUTION

- Unplug the copier power cord before starting the following procedure.

1. Remove all tapes.

2. Left cover (page 211)

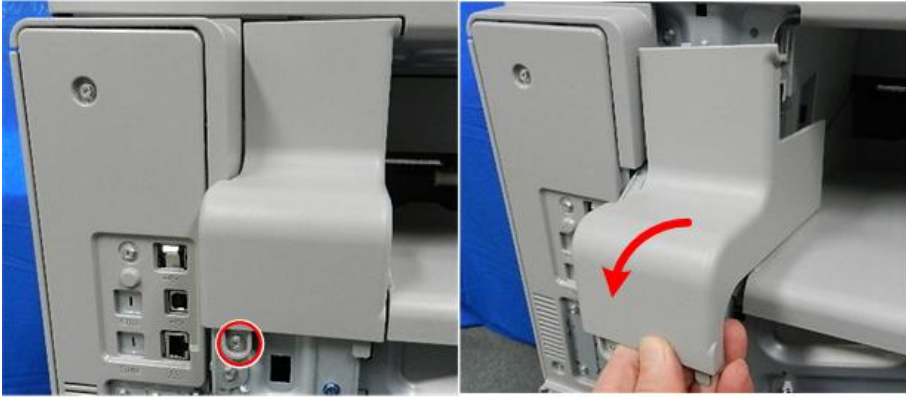

d191b0024

2

3. Left upper cover (x 1)



m370i503

4. Attach the three harness clamps.

5. Inner rear left cover [A] (x 1)

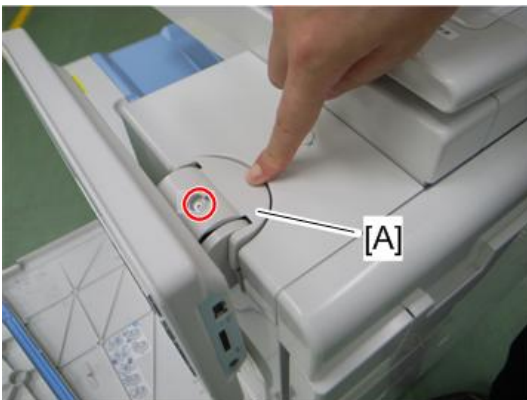

m370i504

6. Operation panel arm cover [A]

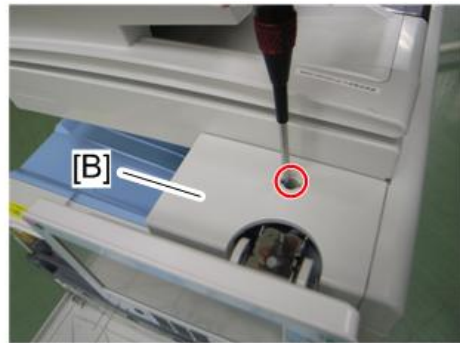
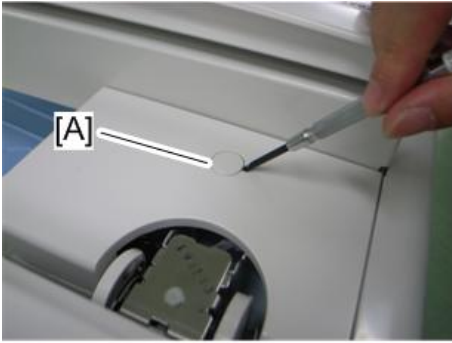

m370i505

- 7. Upper front cover cap [A]
- 8. Upper front cover [B] (⚙️ x 1)
- 9. Open the duplex unit.

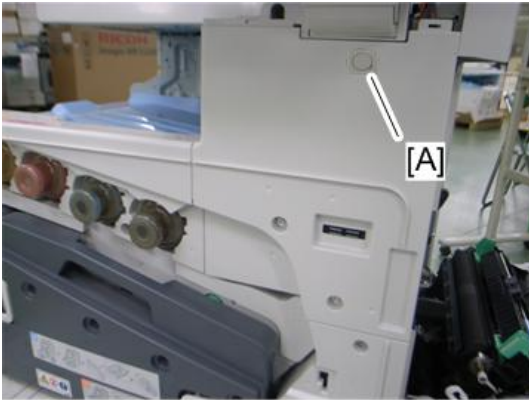

m370i506a

- 10. Inner right cover cap [A]

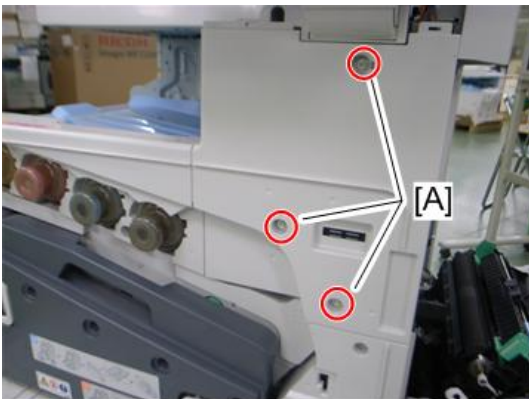

m370i506

- 11. Inner right cover [A] (⚙️ x 3)

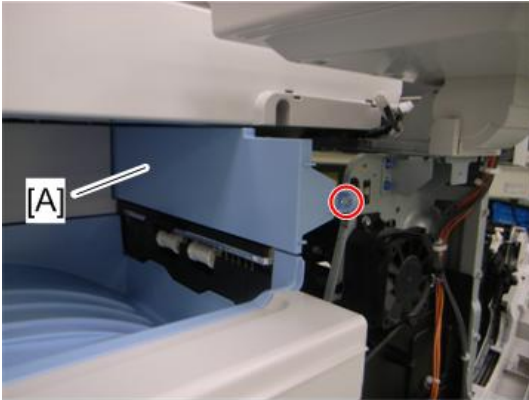

m370i507

- 12. Paper exit cover [A] (🔩 x 1)

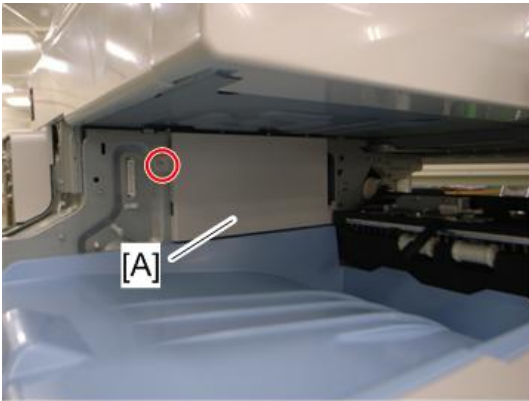

m370i508

- 13. Inner rear right cover [A] (🔩 x 1)



m370i509

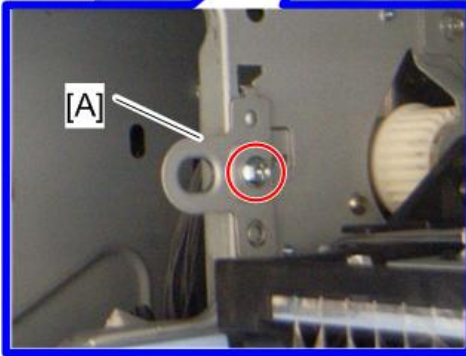

14. Attach the bracket [A] (⚙ x 1: M3x8).

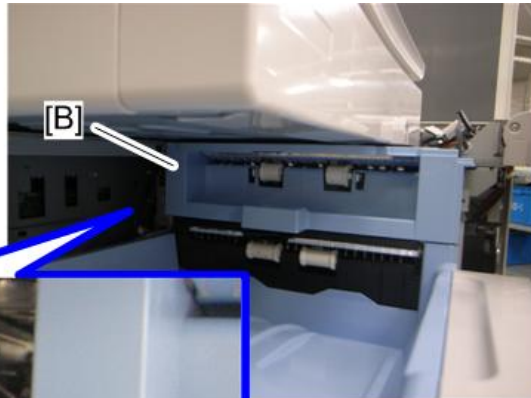

m370i510

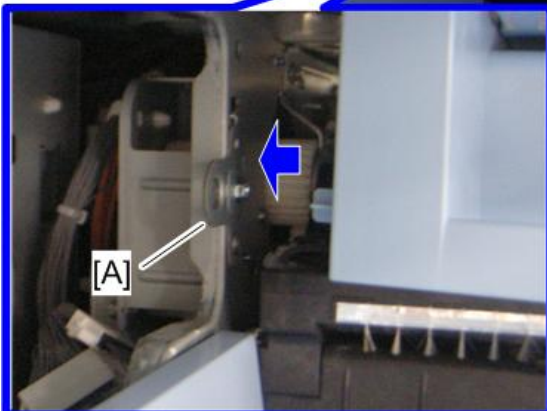

15. Set the shaft of the 1-bin tray unit [B] into the hole in the bracket [A].

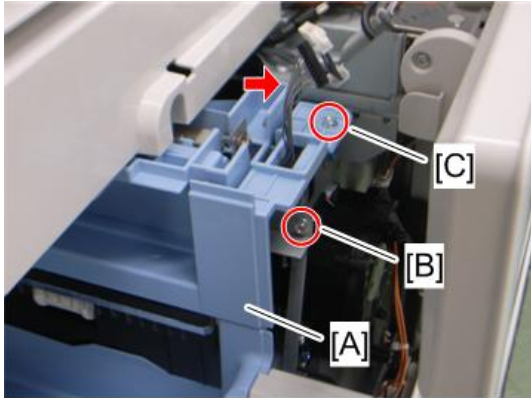

m370i511

16. Install the 1-bin tray unit [A] (2: screw [B]: removed in step 12, screw [C]:M3x8, 1).

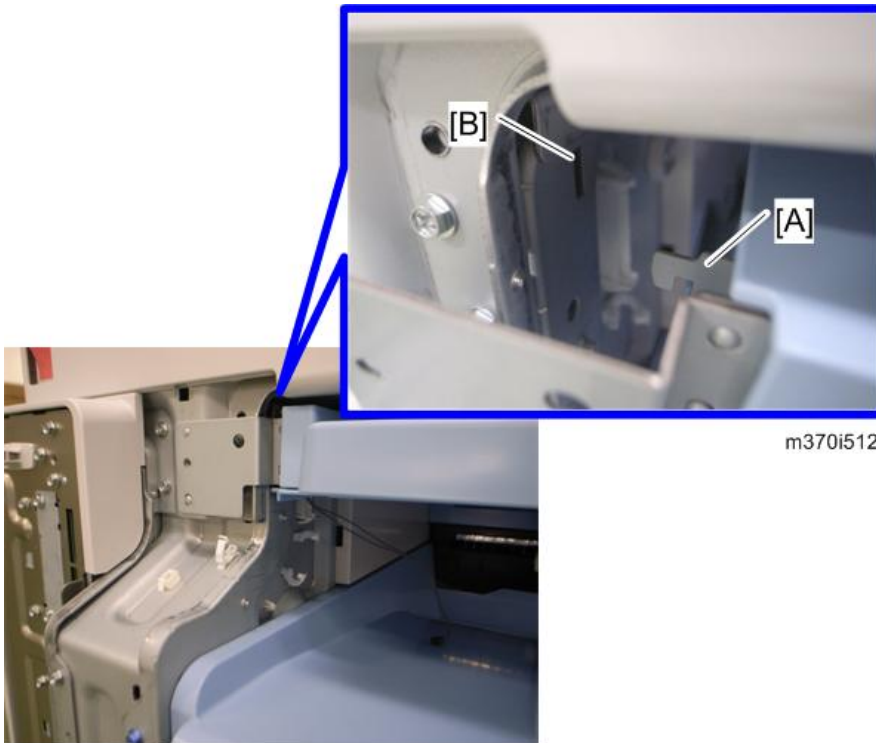

m370i512

17. Set the hook [A] of the 1-bin tray into the hole [B] in the machine.

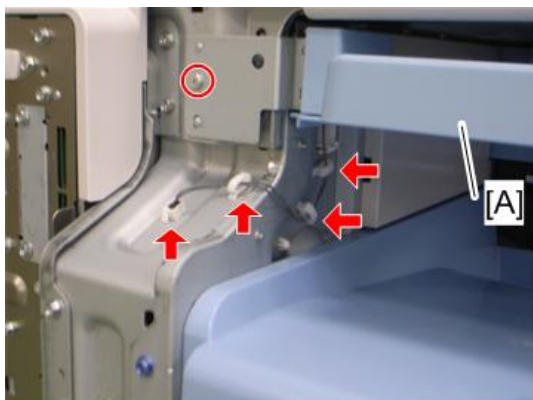

m370i513

18. Install the 1-bin tray [A] (🔩 x 1: bind screw: M3x6, 📏 x 1, 📏 x 3).
19. Reassemble the machine.
20. Turn on the main power switch of the machine, and check the 1-bin tray unit operation.

Enhanced Security HDD Option Type M10 (D792-09)

Accessory Check

2

No.	Description	Q'ty
1	Enhanced Security HDD	1



d191b0076

Installation

1. Rear cover (📄 page 213)
2. Controller box cover (📄 page 422)



d191b0016

3. The standard HDD unit is located at the left rear corner of the machine.

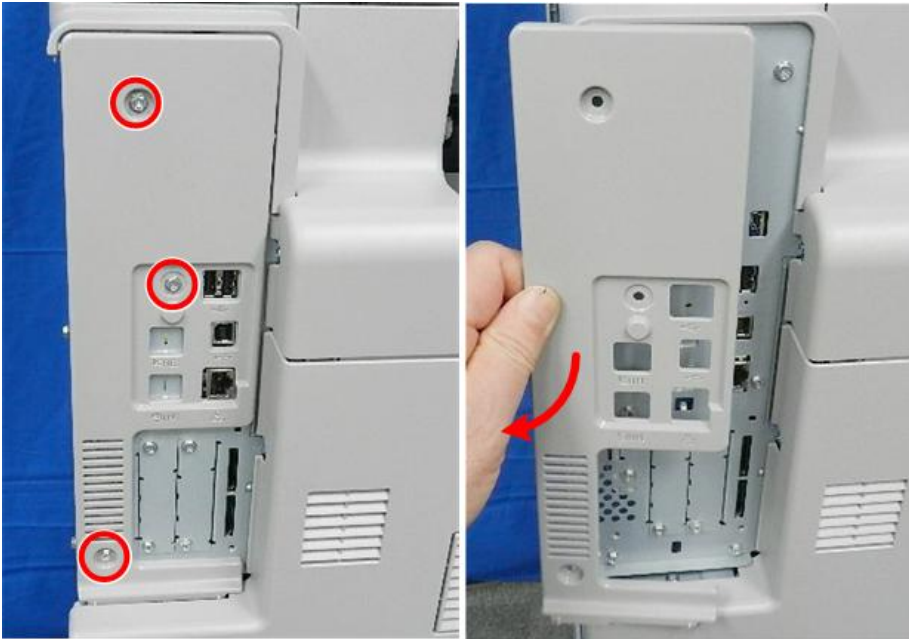

d191b0051

4. Remove the controller box faceplate (🔧x3).



d191b0017

5. Disconnect the edge of the standard HDD unit bracket (🔧 x2).



d191b0018

6. Disconnect the other edge of the bracket (🔧 x2).



d191b0019

7. Pull the bracket away slightly, disconnect the standard HDD unit, and then remove it (with HDD attached) (🔧 x2).

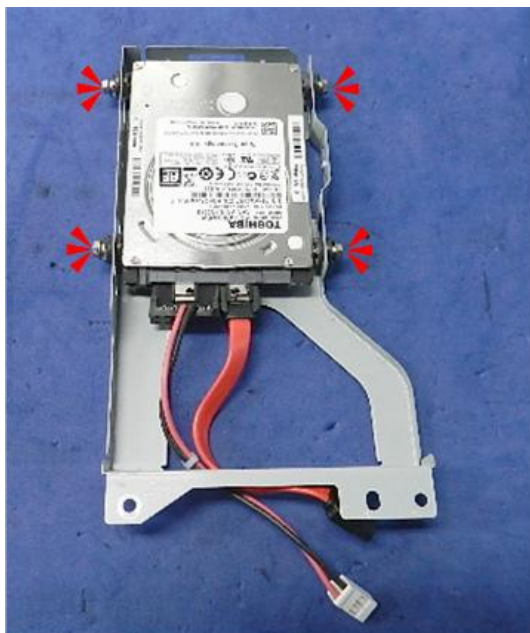

d191b0020



d191b0084

8. Disconnect the standard HDD (🔧x4).



d191b0021

9. Separate the standard HDD from the bracket.



d191b0077

10. Disconnect the cables from the standard HDD (x2).

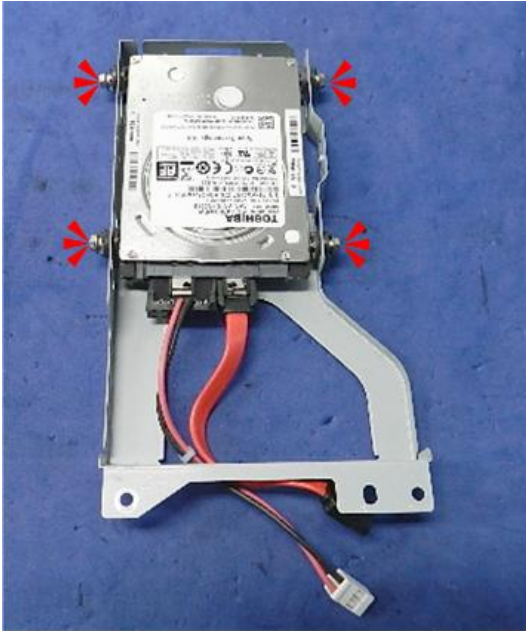

d191b0020

13. Fasten the HDD to the bracket (🔩x4).



d191b0080

14. Mount the HDD bracket (🔩x2, 🛠️x4).
 15. Re-assemble the machine covers.

After Installing the HDD

1. Connect the power cord and turn the machine on. A message prompts you to format the hard disk.



d191b0081

2. Touch [Format].

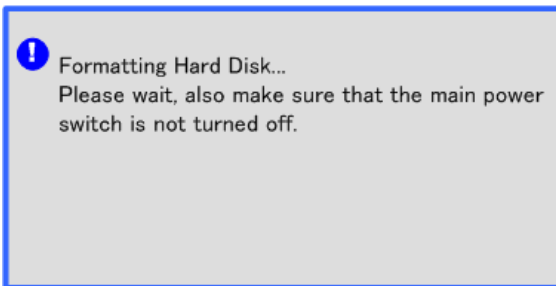

d191b0082

3. Wait for the machine to finish formatting the hard disk.

★ Important

- Do not touch the power switch while the hard disk format is in progress. Wait for the machine to tell you that the formatting is finished.

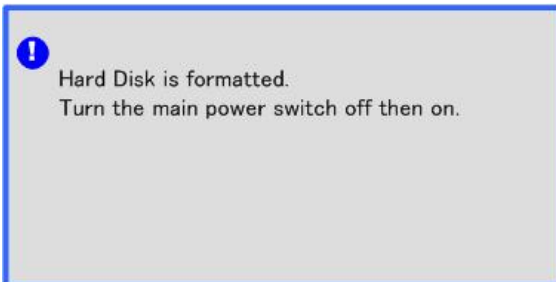

d191b0083

4. Cycle the machine off/on after the message tells you formatting is finished.
5. Enter the SP mode.
6. Do **SP5-853-001** to copy the preset stamp data from the firmware to the hard disk. Follow the instructions on the screen. This will require three or four minutes.
7. Do **SP5-846-040** to copy the address book to the hard disk from the controller board.
8. Do **SP5-846-041** to let the user get access to the address book.
9. Cycle the machine off/on.

10. Ask an administrator to register an HDD authentication code in the machine.

 **Important**

- **If the HDD Authentication Code is not registered, the function of the enhanced security HDD is not activated.**

Optional Counter Interface Unit (B870)

Installation Procedure

2

1. Rear cover (🔗 page 213)
2. Controller box cover (🔗 page 422)

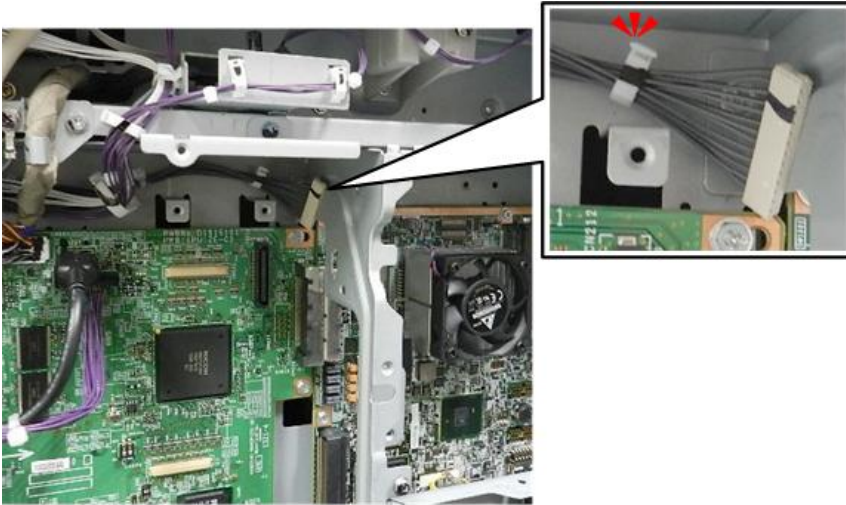

d191b0025

3. Release the harness (🔗 x1).

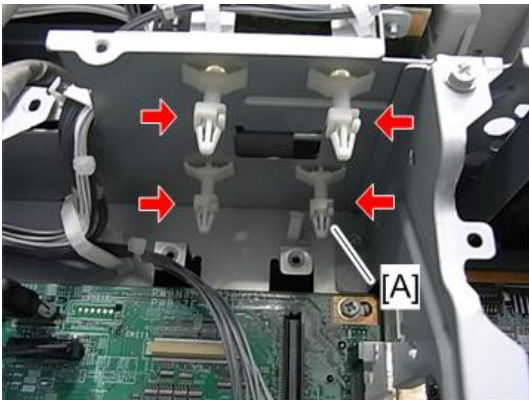

m022i525

4. Install the four studs [A] in the controller box.

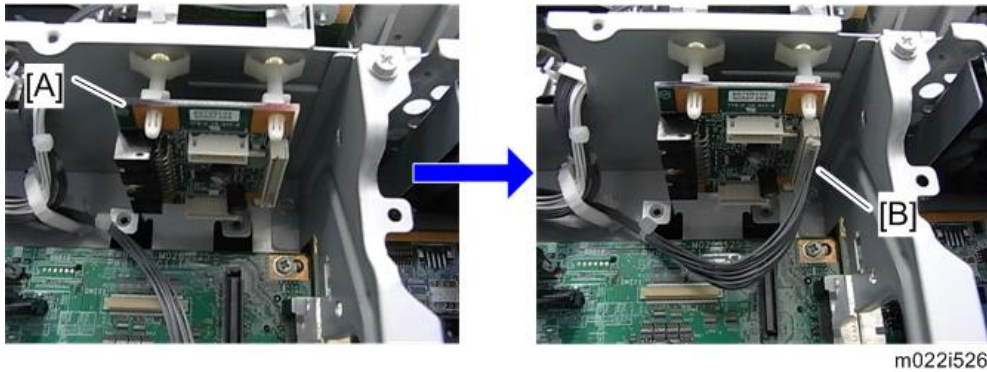

5. Install the key counter interface board [A] on the four studs.
6. Connect the harness [B] to the key counter interface board [A].
7. Connect the harness from the counter device to CN4 on the key counter interface board.

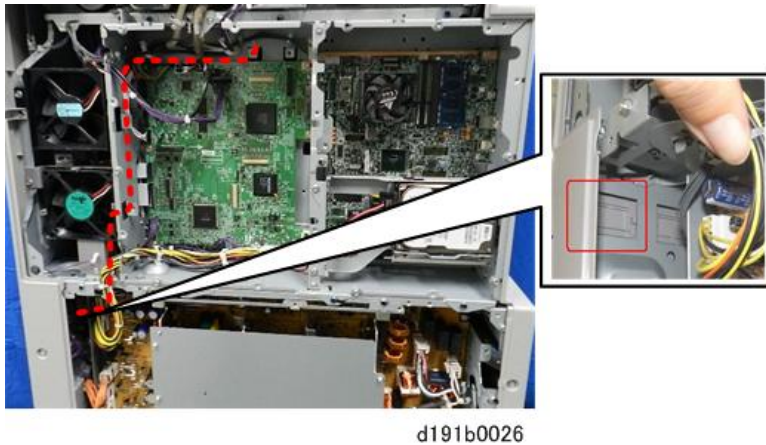

8. Route the harness.

Note

- Remove the cover [A], and route the harness as shown above.

9. Reassemble the machine.

Note

- Remove the optional counter interface unit when opening or removing the controller box.

Copy Data Security Unit (D640)

Accessories

No.	Description	Qty
1	Copy Data Security Board	1
2	Screws M3x8	2

Note

- Some accessories in the kit are not used for this machine.

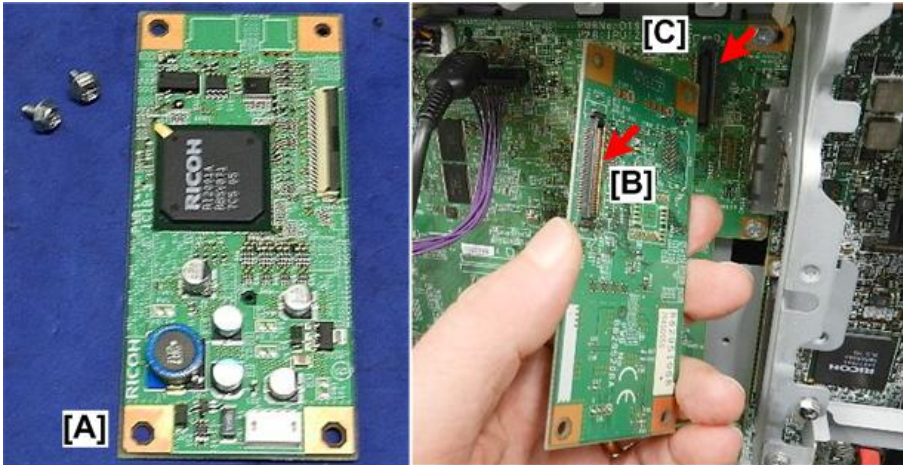

d191b0027

The copy data security option is a small board [A] with a socket connector on its underside [B] that fits into a receptacle [C] on the IPU.

Installation

CAUTION

- Unplug the main machine power cord before you do the following procedure.
- Rear cover (page 213)
 - Controller box cover (page 422)



d191b0028

3. Align the holes of the board [A] with the holes on the bracket, and then push gently on the front of the board so it connects to the IPU.
4. Make sure that the board [B] is flat, and then fasten it to the bracket (⚙️x2).

User Tool Setting

1. Plug in and turn on the main power switch.
2. Press [User Tools] and then select: System Settings > Administrator Tools > Copy Data Security Option > On
3. Exit User Tools.
4. Check the operation.
 - The machine will issue SC165-00 if the machine is powered on with the
 - Copy Data Security Unit Board removed and the "Data Security for Copying" feature set to "ON".
 - The machine will issue SC165-00 if the machine is powered on with a defective Copy Data Security Unit Board and the "Data Security for Copying" feature set to "OFF".
 - If you remove this option from the machine, first set the setting to "OFF" with the User Tools before removing this board. If you forget to do this, the "Data Security for Copying" feature cannot appear in the User Tool settings, and SC165-00 will appear every time the machine is switched on. The machine cannot be used.
 - Go into User Tools and make sure that the machine can recognize the option.

Tray Heater (Mainframe)

Installation Procedure

Note

- This heater is supplied as a spare part.

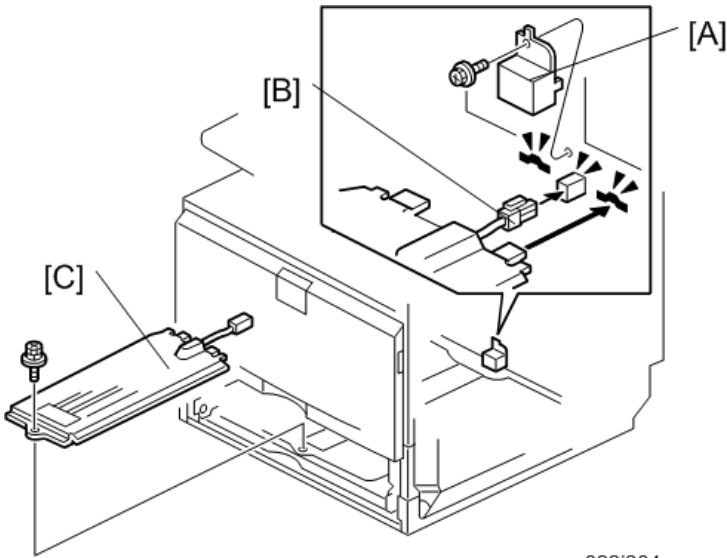

1. Remove tray 1 from the machine.
2. Remove the connector cover [A] (⚙ x 1).
3. Connect the connector [B] of the heater to the connector of the main machine.
4. Install the heater [C] inside the machine (⚙ x 1).
5. Reassemble the machine.

Tray Heater (Optional Unit)

Component Check

Check the quantity and condition of the accessories against the following list.

No.	Description	Q'ty
1	Tray heater	1
2	Harness 1	1
3	Harness 2	1
4	Screw (M4 x 10)	1
5	Clamp 1	3
6	Clamp 2	1

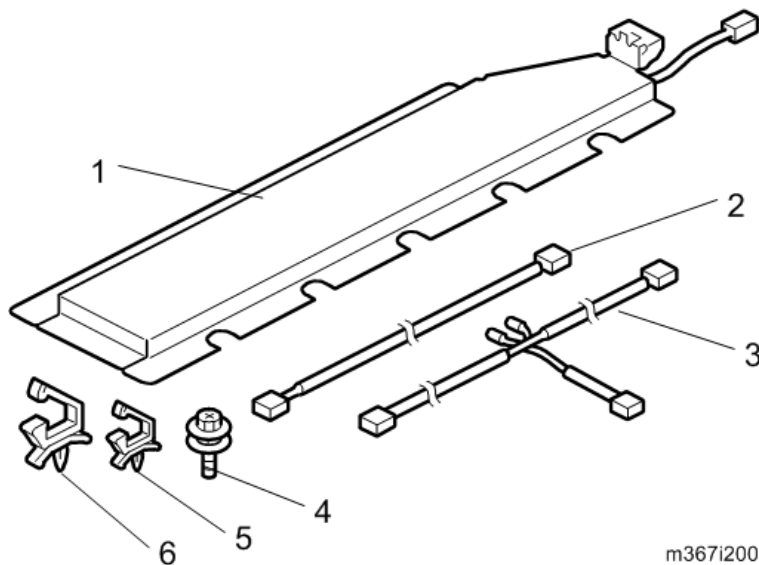

m367i200

Installation Procedure

⚠ CAUTION

- Unplug the machine power cord before starting the following procedure.
- Do the following procedure not to damage any harnesses.

- Check that harnesses are not damaged or pinched after installation.

For Installing the Tray Heater in M367

2

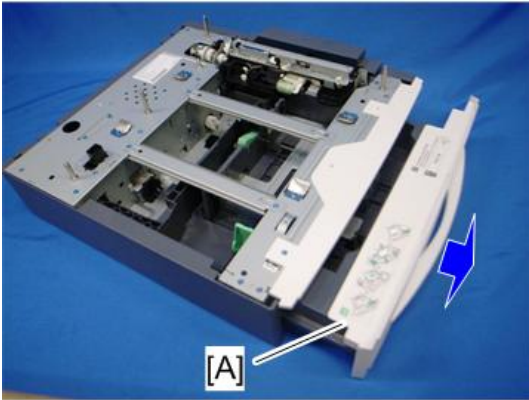

m367i512

1. Pull out the tray [A] in the optional paper tray.

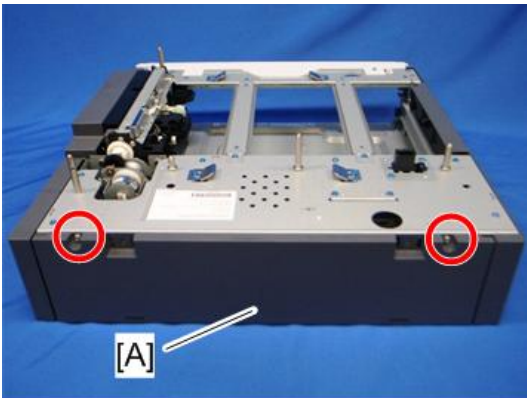

m367i513

2. Rear cover [A] (🔩 x 2)

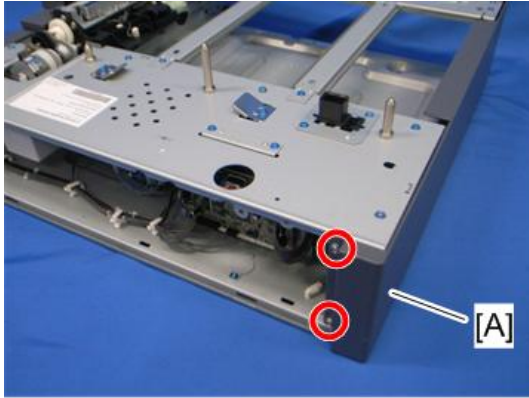

m367i514

3. Left cover [A] (⚙ x 2)

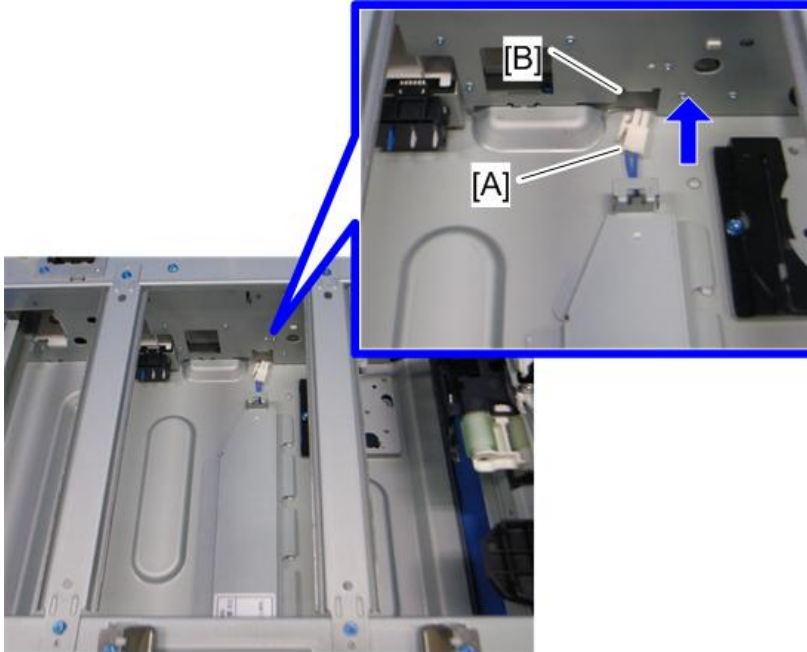

m367i515

4. Pass the heater harness [A] through the square hole [B].

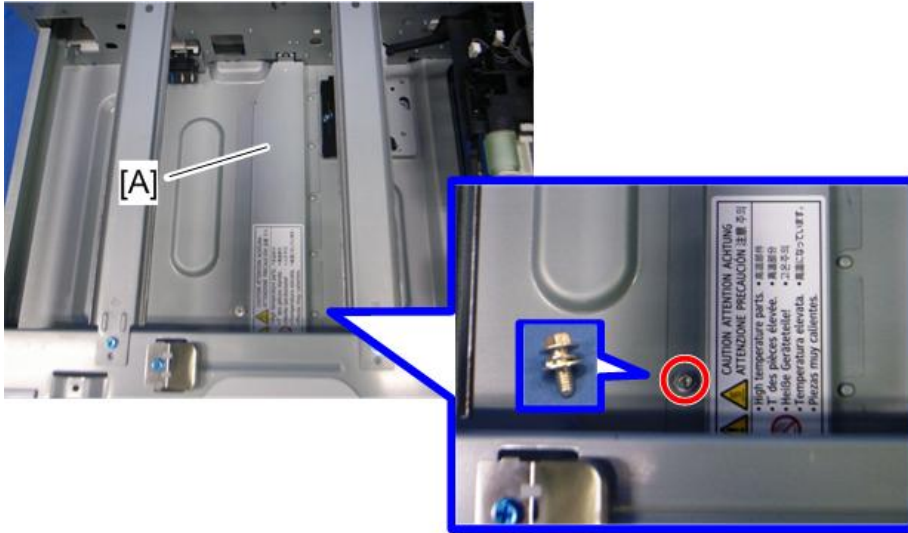

m367i516

5. Install the tray heater [A] in the paper feed unit (🔩 x 1).

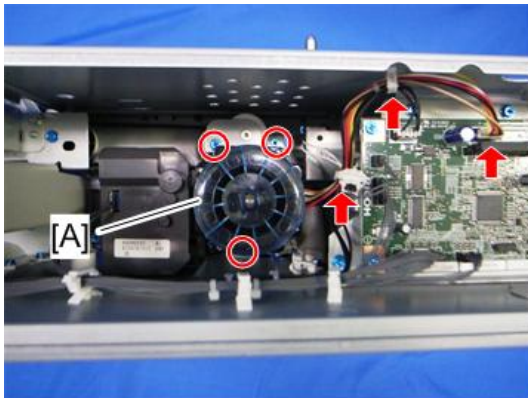

m367i517

6. Paper feed motor bracket [A] (🔩 x 3, 📏 x 1, 📏 x 2)

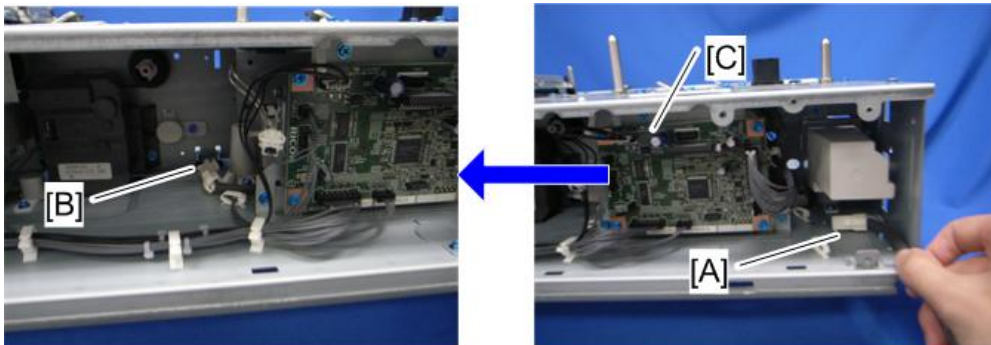

m367i518

7. Connect the relay harness (harness 2) [A] to the heater harness [B].

Note

- Pass the relay harness (harness 2) [A] behind the drive board [C] as shown above.

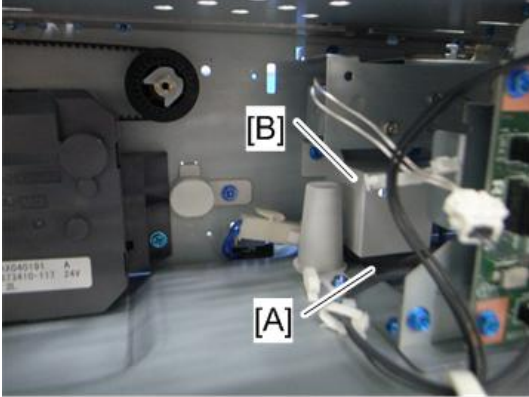

m367i519

8. Locate the relay harness (harness 2) [A] under the inner cover [B] as shown above.

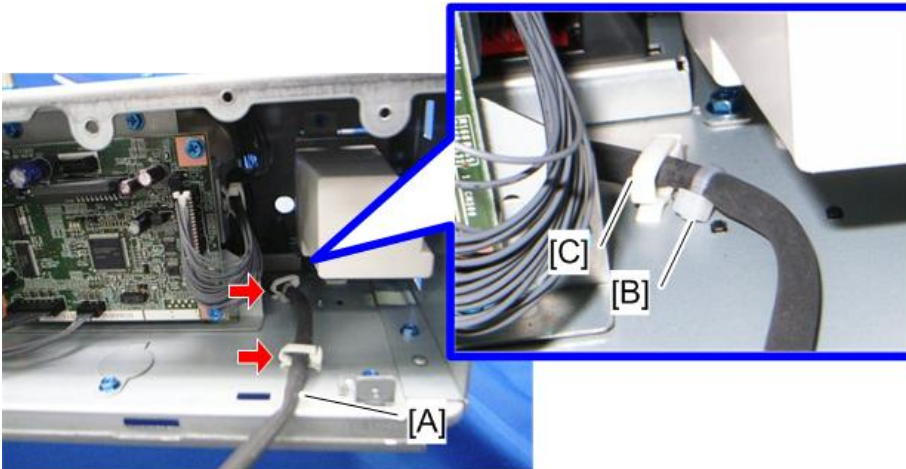

m367i520

9. Clamp the relay harness (harness 2) [A] (2 x 2)

Note

- Make sure that the binding [B] is in front of the clamp [C] as shown above.

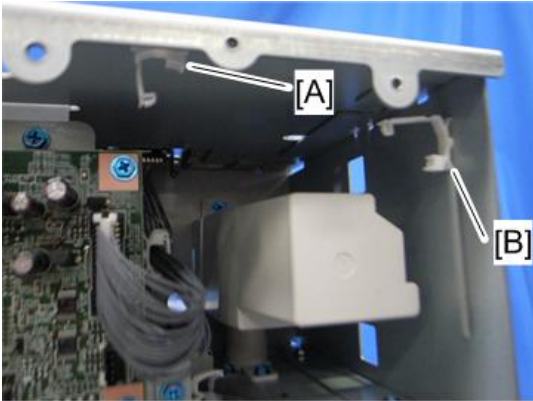

m367i521

10. Attach the clamp 1 [A] and the clamp 2 [B].

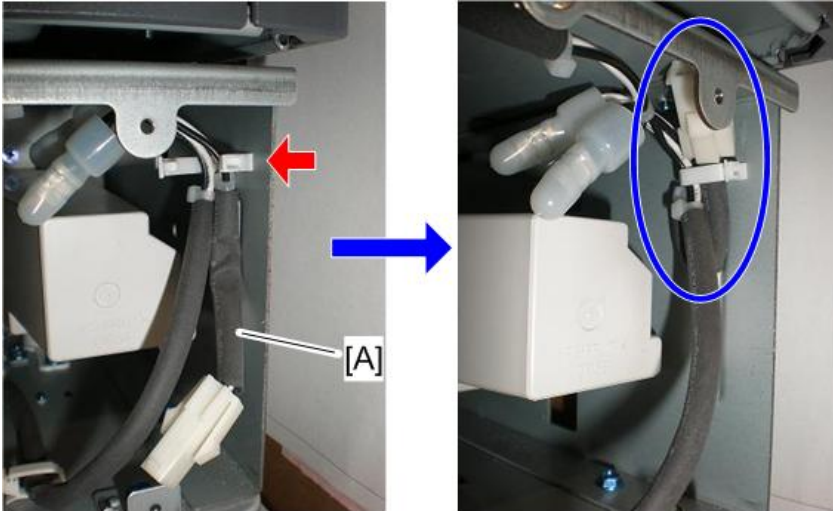

m367i522

11. If you do not install M368, fold the relay harness (harness 2) [A], and then clamp it as shown above.

Go to step 12 if you install M368 below M367. If not, go to step 13.

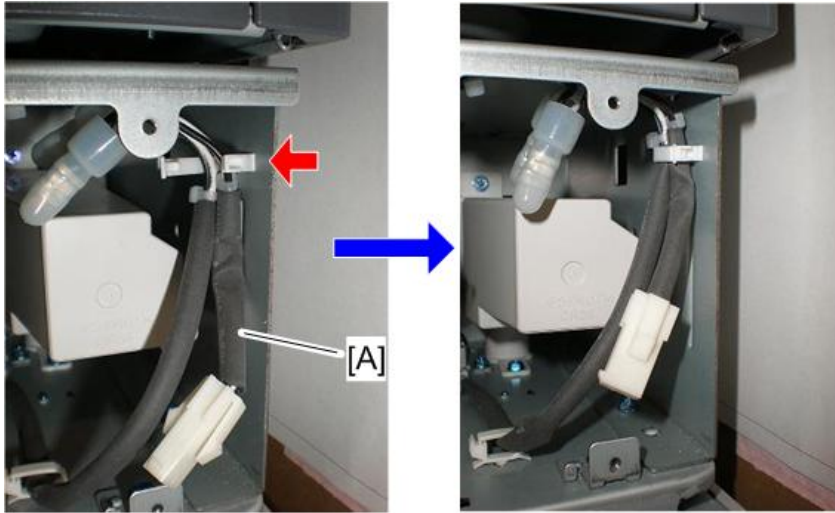

m367i523

12. Clamp the relay harness (harness 2) [A].



m367i524

13. Clamp the relay harness (harness 2) [A].
14. Remove the rear lower cover of the machine (⚙ x 3).

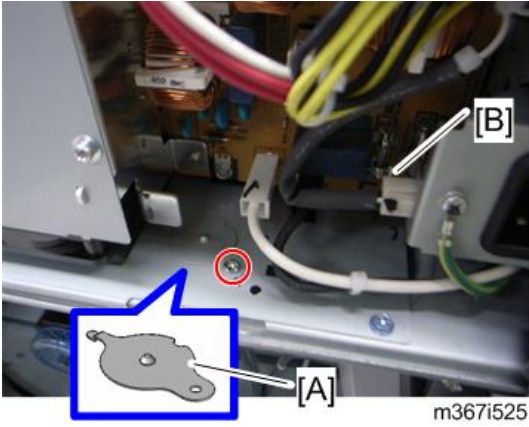

15. Remove the harness cover bracket [A] (1 x 1)

16. Remove the connector [B] of the machine.

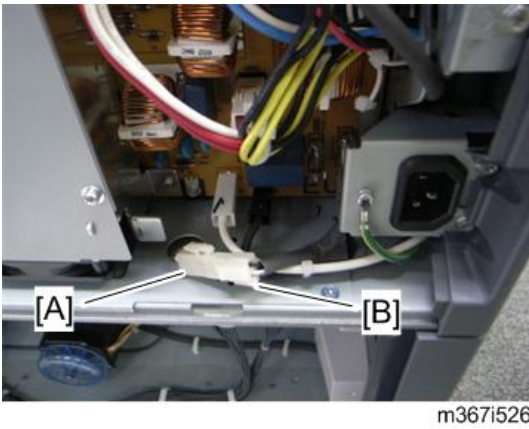

17. Connect the harness [A] to the connector [B] of the machine.

18. Reassemble the machine.

For Installing the Tray Heater in M368



m368i509

1. Pull out the trays [A] in the optional paper tray.

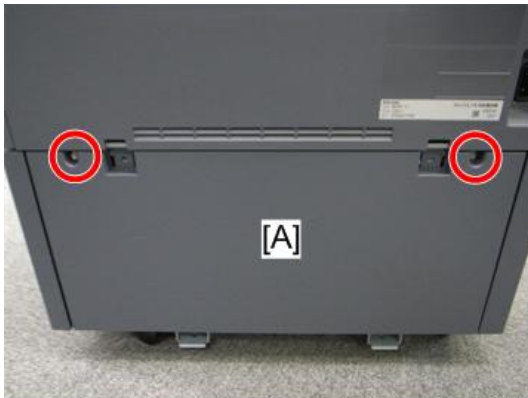

m368i510

2. Rear cover [A] (🔩 x 2)

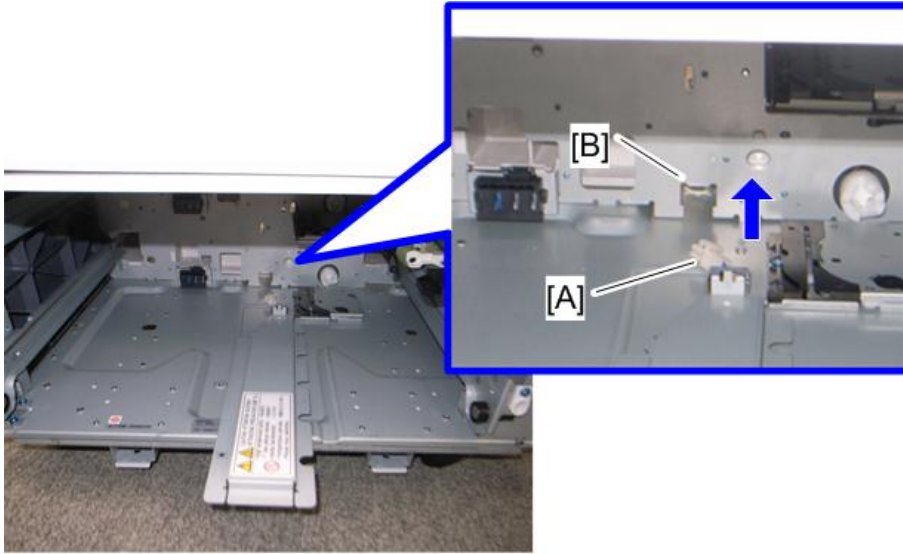

m368i511

3. Pass the heater harness [A] through the square hole [B].

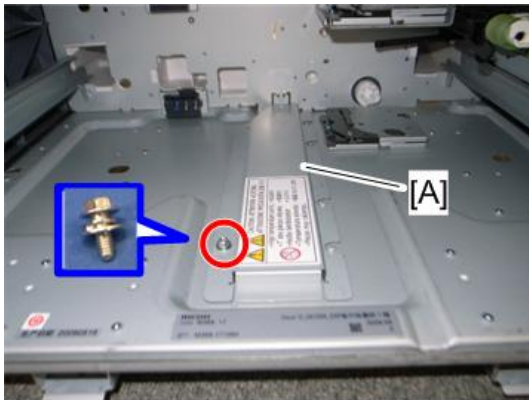

m368i512

4. Install the tray heater [A] in the paper feed unit (⚙ x 1).

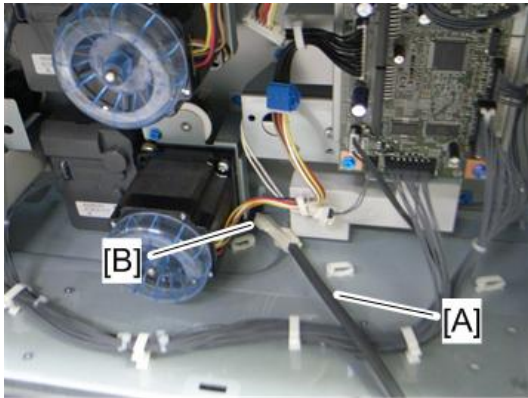

m368i513

5. Connect the relay harness (harness 1) [A] to the heater harness [B].

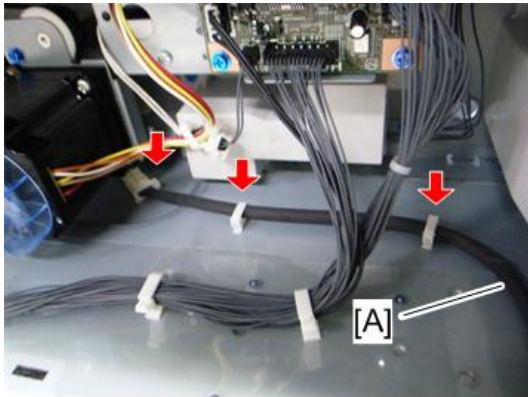

m368i514

6. Clamp the relay harness (harness 1) [A] (🔧 x 3).

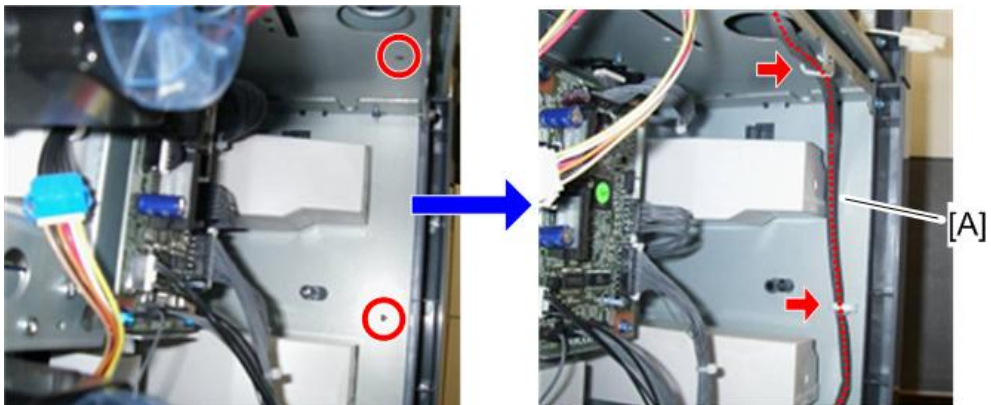

m368i515

7. Remove the rear lower cover of the machine (🔧 x 3).
8. Attach the two clamps (clamp 1), and then clamp the relay harness (harness 1) [A] (🔧 x 2).

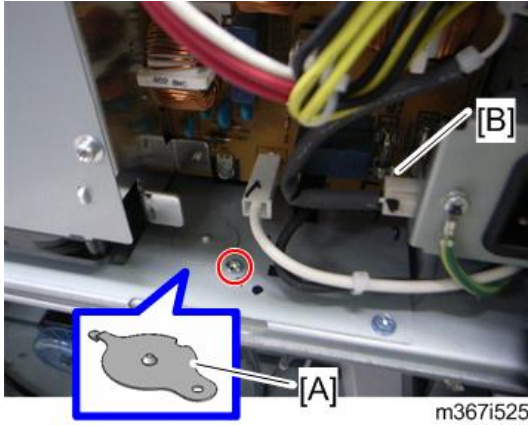

9. Remove the harness cover bracket [A] of the machine.

10. Remove the connector [B] of the machine.

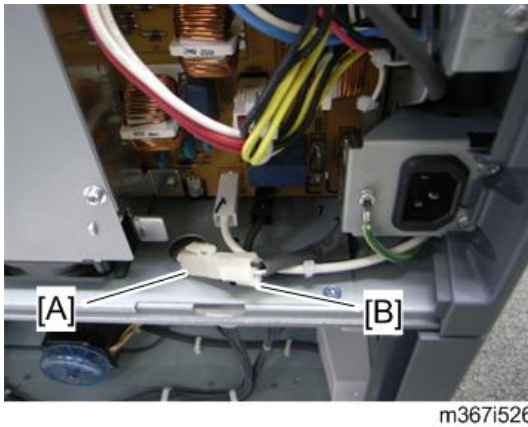

11. Connect the harness [A] to the connector [B] of the machine.



12. Make sure that the harness (harness 1) [A] is placed securely as shown above.

13. Reassemble the machine.

Smart Operation Panel Type M10 (D190)

⚠ WARNING

- Always replace a lithium battery on a PCB with the same type of battery prescribed for use on that board. Replacing a lithium battery with any type other than the one prescribed for use on the board could lead to an explosion or damage to the PCB.
- Never discard used batteries by mixing them with other trash. Remove them from the work site and dispose of them in accordance with local laws and regulations regarding the disposal of such items.

Accessories

Check the items to make sure that you have all the accessories shown below.

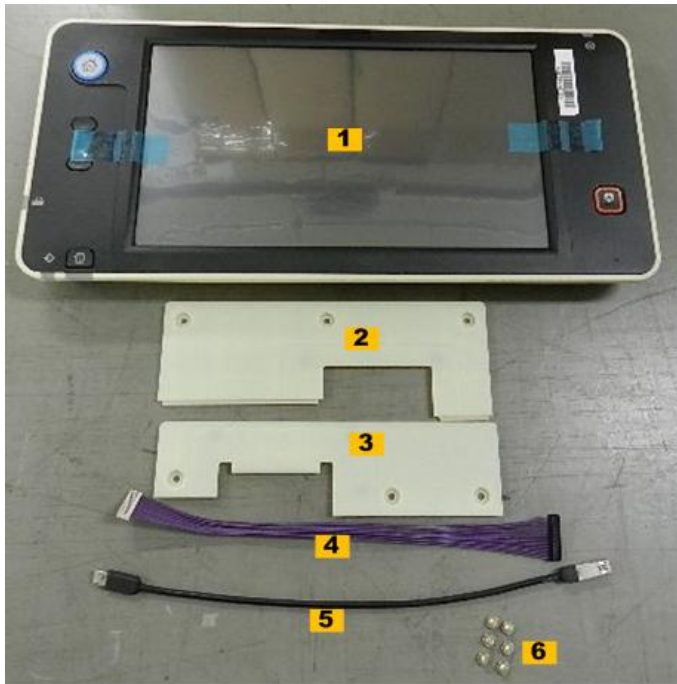

d190b0001

No.	Description	Q'ty
1	Smart Operation Panel	1
2	Operation Panel Rear Bottom Cover	1
3	Operation Panel Rear Top Cover	1

No.	Description	Q'ty
4	I/F Harness	1
5	USB Cable	1
6	Screws	6

Before Installation

Prepare an SD card which contains the system copy firmware and package firmware of the Smart Operation Panel Type M10 for the D191/D193.

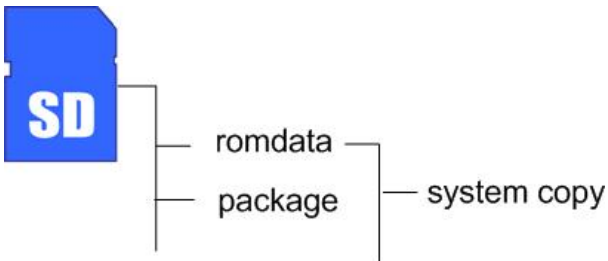

d191z5003

Installation

Firmware Update, Initial SP Settings



d190b0002

1. Remove the SD card slot cover (1x1).

2. Insert the Smart Operation Panel SD card in SD Card Slot 2.
3. Turn the machine on.

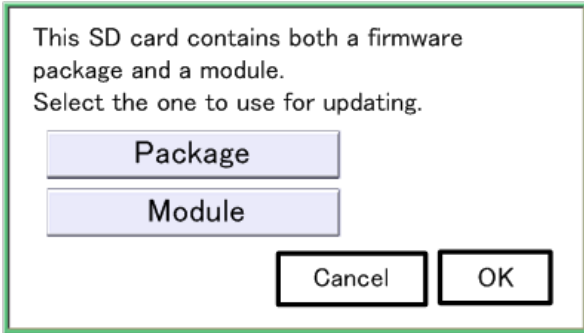

d176f2128

4. The selection screen shown above is displayed.
5. Press "Module" button, and then press "OK" button.
6. Select the system copy firmware of the smart operation panel type M10 for the D191/D193 first.
7. Follow the instructions on the screen to complete the firmware update.
8. "Update is Done" or a similar message appears on the operation panel after completing the firmware update.
9. Switch machine off and on.

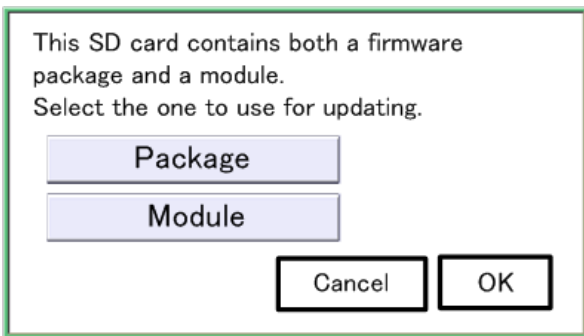

d176f2128

10. The selection screen shown above is displayed again.
11. Press "Package" button, and then press "OK" button.

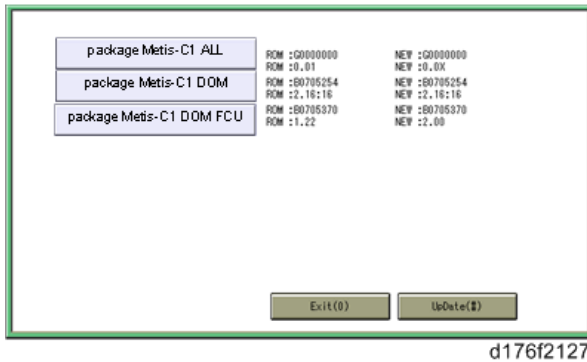

12. Select the target package firmware of the smart operation panel type M10 for the D191/D193.
13. Follow the instructions on the screen to complete the firmware update.
14. Switch machine off when you see the "Update is Done" message or follow the procedure that is displayed on the operation panel.
15. Press in the SD card to release it, and then remove it from the slot 2.
16. Switch the machine on.
17. Enter the SP mode.
18. Set System SP **SP5-748-101** Bit 0 to "1"
19. Set System SP **SP5-748-201** to "1"
20. Close the SP mode.
21. Switch the machine off and unplug the machine from its power source.

Removing Standard Operation Panel and Hinge

⚠ CAUTION

- Before you do this installation procedure, make sure that the machine is switched off and disconnected from its power source.

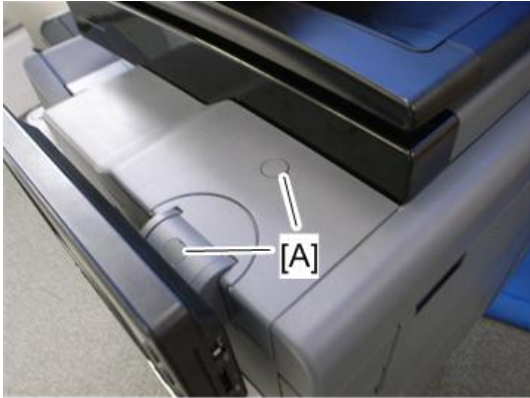

d190b0003

1. Remove caps [A].

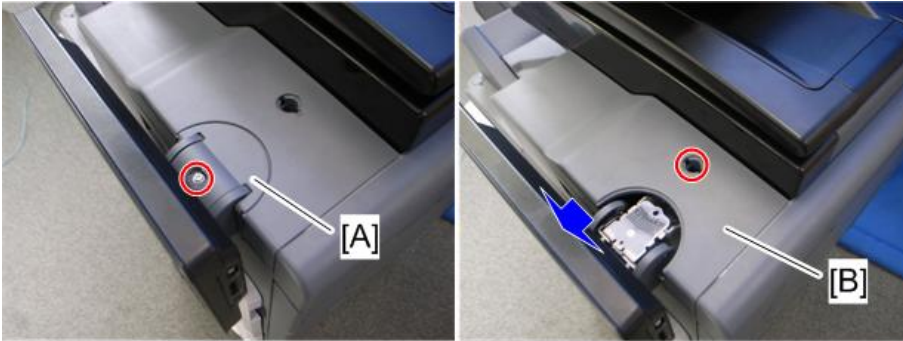

d190b0004

2. Remove cover [A] (🔧x1).
3. Remove cover [B] (🔧x1).

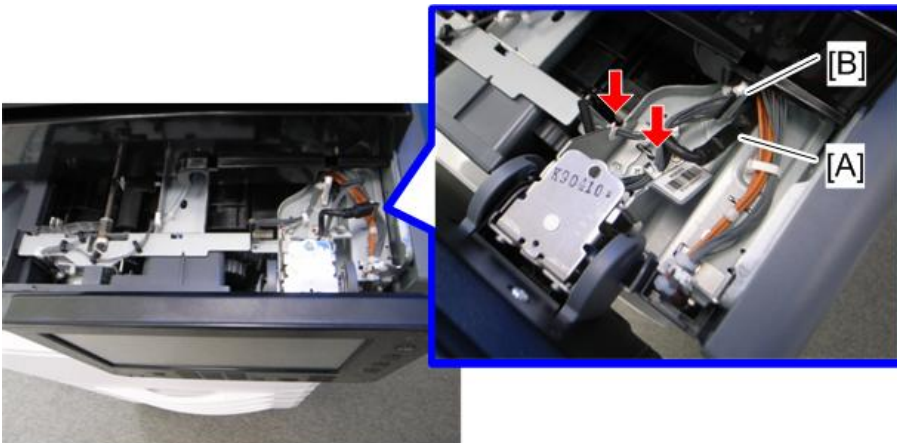

d190b0005

4. Disconnect USB cable [A] and I/F harness [B] (🔧x2, 🔧x2).

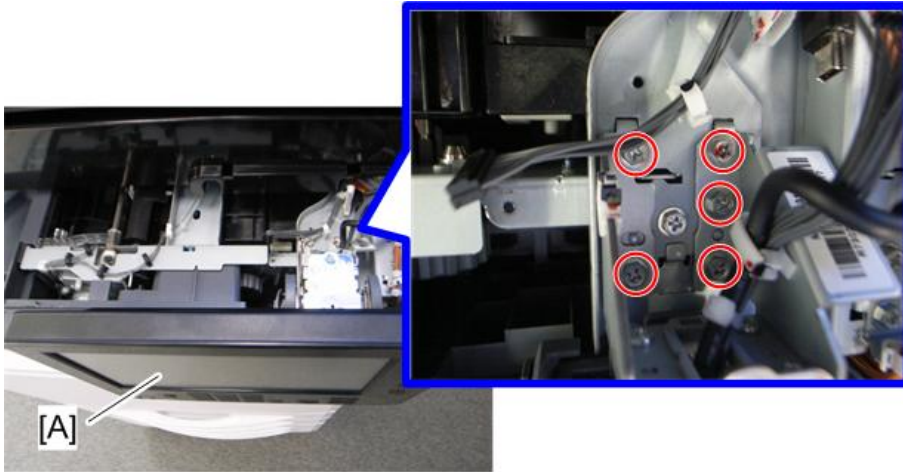

d190b0006

5. Disconnect base of operation panel [A] (⚙️x5).

Note

- Save these screws. You will need these screws to install the Smart Operation Panel.



d190b0007

6. Remove the standard operation panel.
7. Lay the operation face down on a flat clean surface.

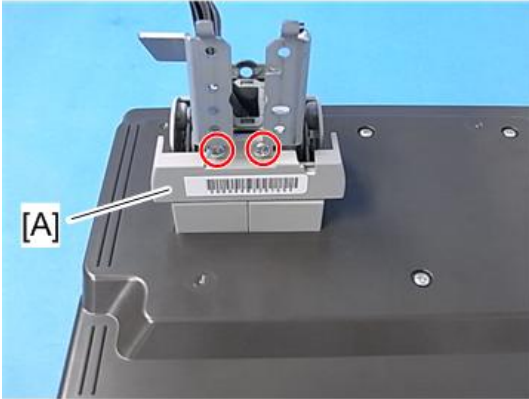

d190b0008

8. Disconnect operation panel hinge bracket cover [A] (⚙️ x2).

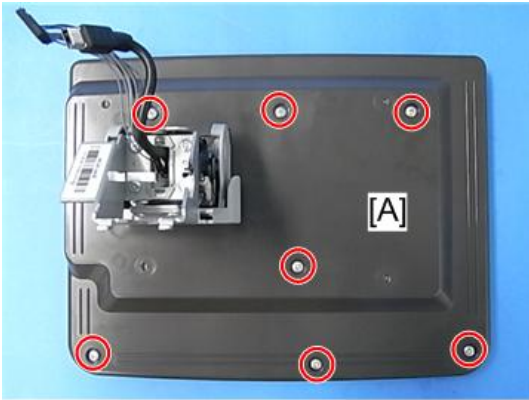

d190b0009

9. Remove rear cover [A] (⚙️ x7)

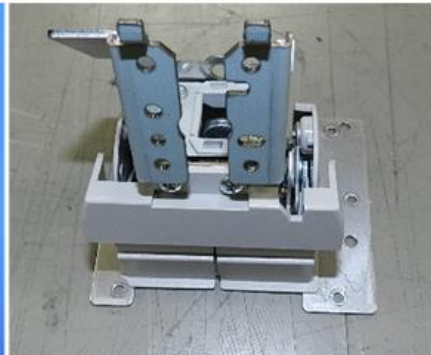
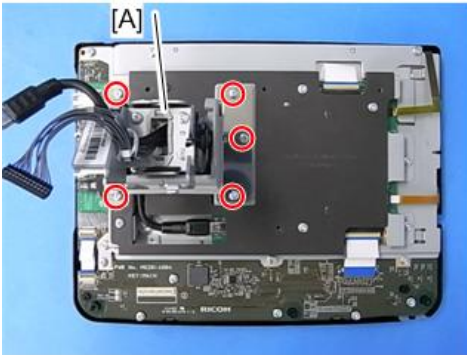

d190b0010

10. Remove hinge bracket (⚙️ x5).

Note

- Save these screws. You will need them to attach the hinge to the back of the Smart Operation Panel.

Smart Operation Panel Installation

2

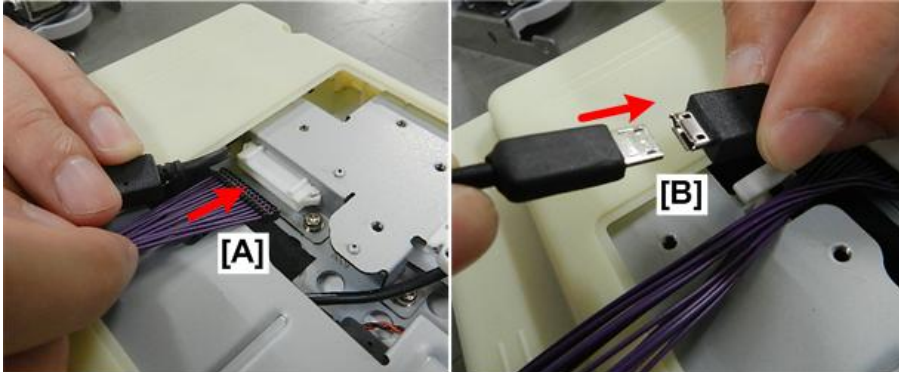

d190b0011

1. Lay the Smart Operation Panel face down on a flat clean surface.
2. Connect I/F harness [A] to the back of the operation panel (1 x1).
3. Connect USB cable [B] to the back of the operation panel (1 x1).

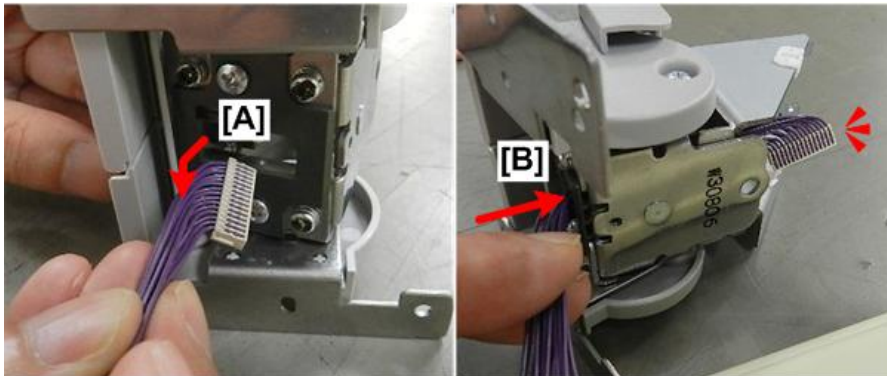

d190b0012

4. Bend the head of I/F harness connector [A] slightly, and then pass it [B] through the hinge bracket.

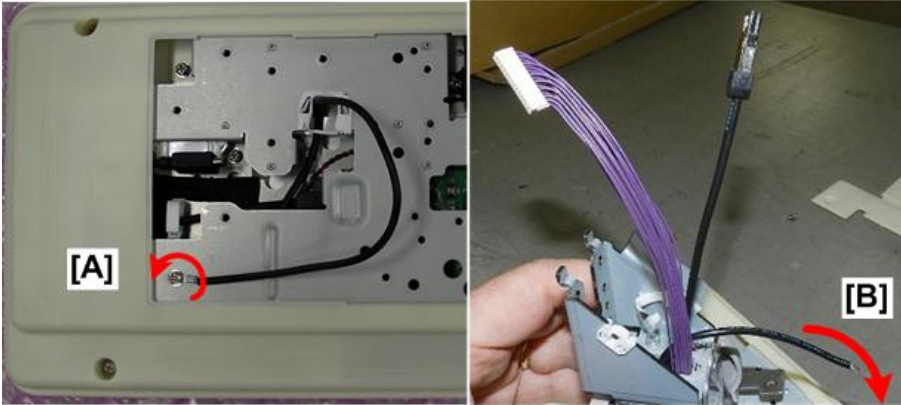

d190b0014

5. Disconnect ground wire [A] from the back of the operation panel (⚠x1).
6. Pass the ground wire [B] through the base hinge.

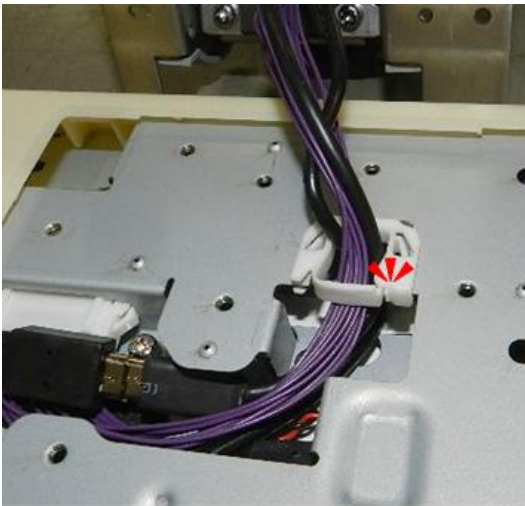

d190b0015

7. On the back of the operation panel close the clamp around I/F harness, USB cable, and ground wire (⚠x1).

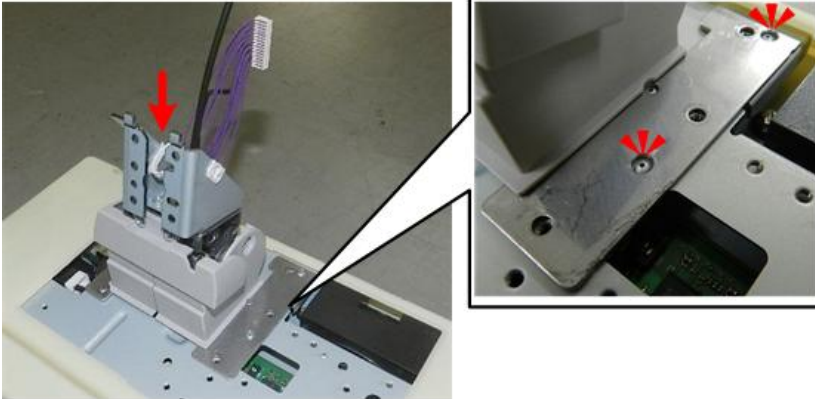

d190b0016

8. Set the hinge bracket on the back of the operation panel with the bosses aligned with the holes of the left bracket plate.

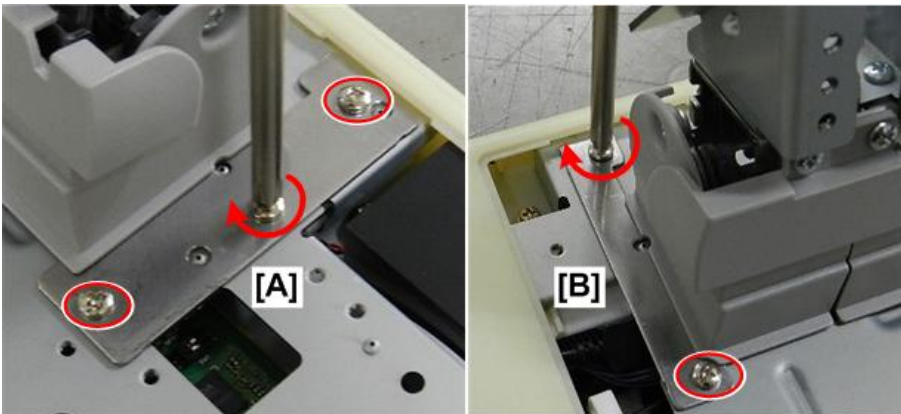

d190b0017

9. Fasten the left side of the bracket [A] (⚙️x3).
 10. Fasten the right side of the bracket [B] (⚙️x2).

Note

- Use the screws that you saved when you removed with the standard operation panel hinge bracket.

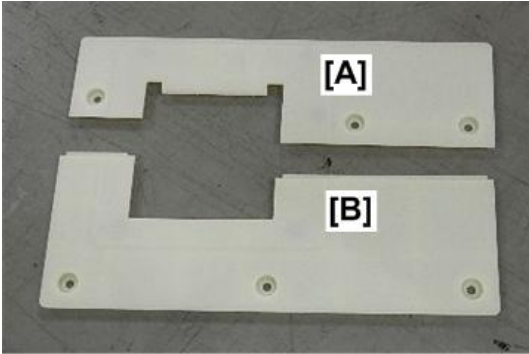

d190b0018

11. There are two rear covers:

[A] Top cover

[B] Bottom cover

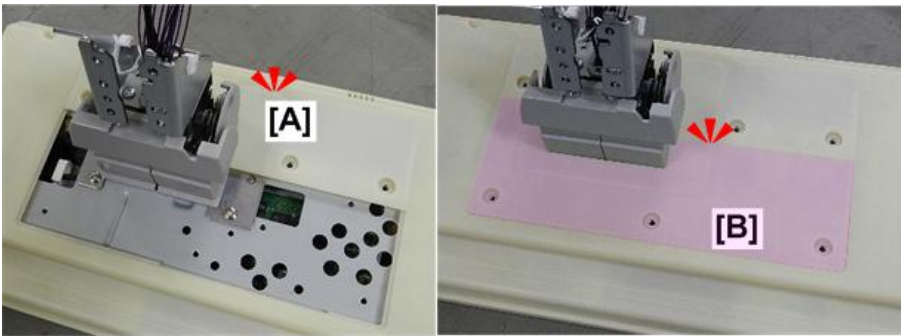

d190b0019

12. Set the top cover [A], and then set the bottom cover [B].

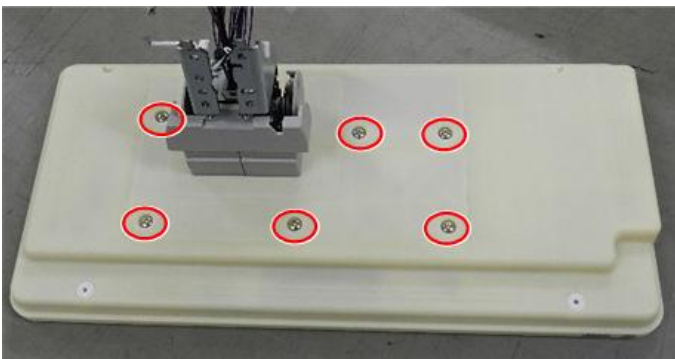

d190b0020

13. Fasten the covers (6 x6). (Use the accessory screws provided.)



d190b0021

14. Remove the screw near the center of the operation panel base plate in the machine. Save this screw to attach the ground wire in the next step.

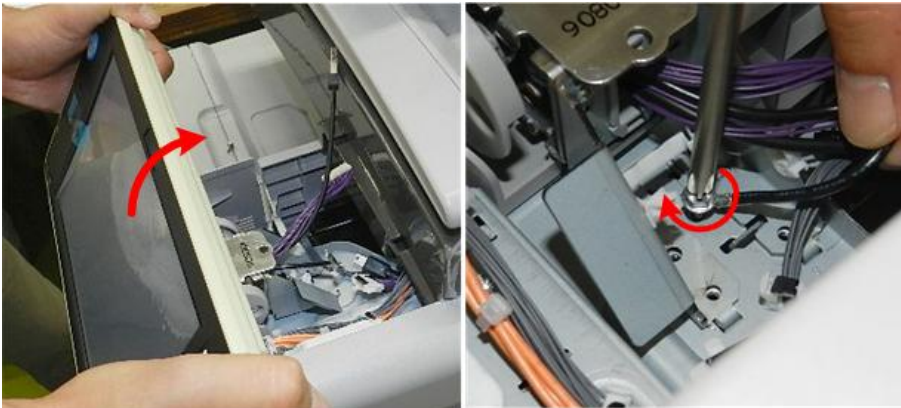

d190b0022

15. Set the operation panel in the machine.
16. Use the removed screw to attach the ground wire.
17. Use the screws removed with the standard operation panel hinge bracket to attach the operation panel.

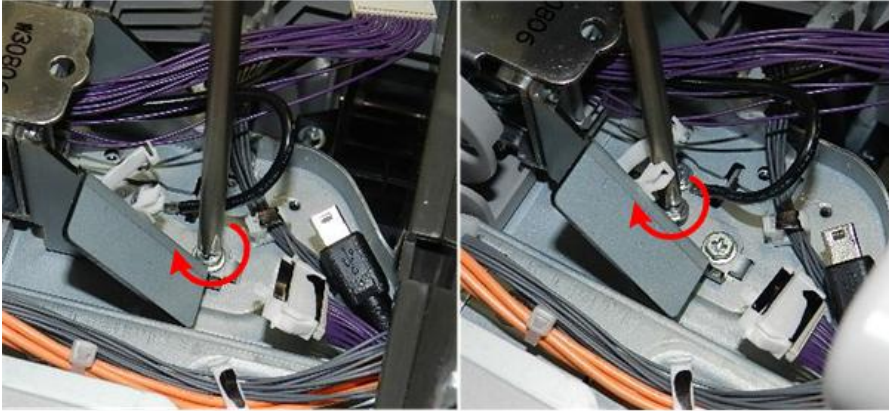

d190b0023

18. Right screws (ϕ x2).

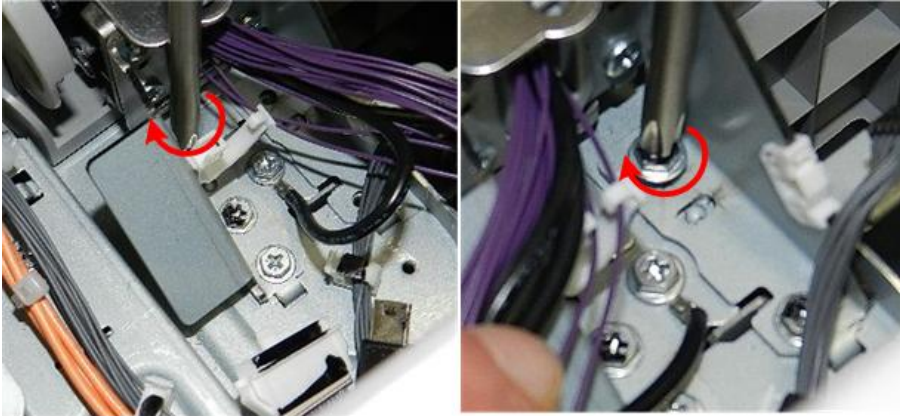

d190b0024

19. Front screws (ϕ x2).

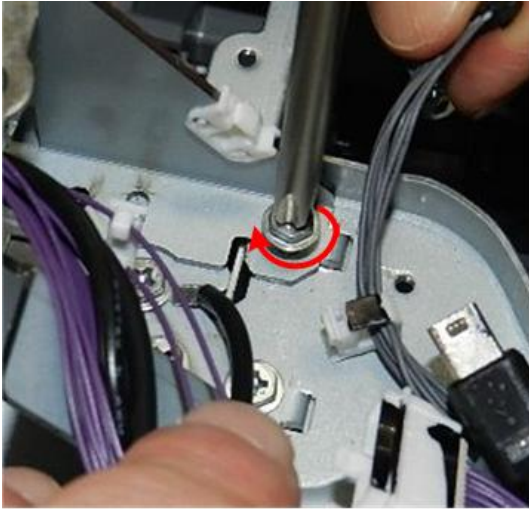

d190b0025

20. Left screw (🔩x1).

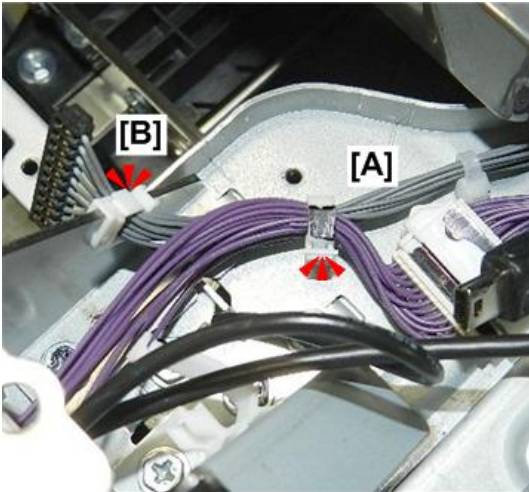

d190b0026

21. Clamp operation panel the two harnesses [A] (🔧x1).
22. Clamp open harness [B] (🔧x1).

⬇️ **Note**

- Harness [B] is not connected to anything for this installation but it must be clamped as shown above.

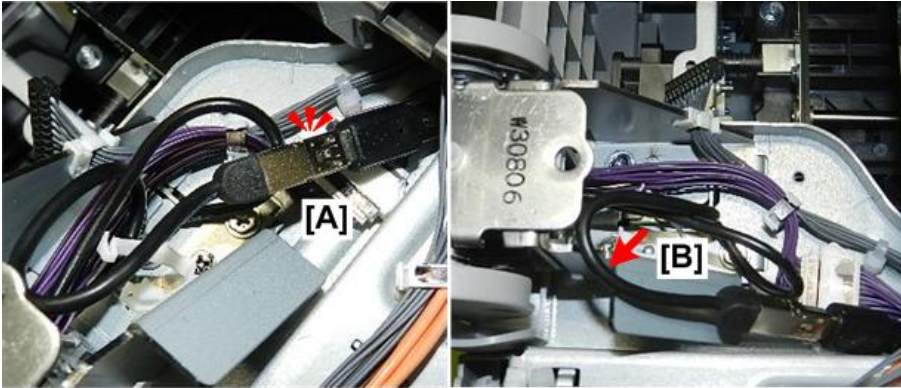

d190b0027

- 23. Connect USB cable [A].
- 24. Arrange the USB cable at [B] so it is flat.



d190b0028

- 25. Re-attach the covers and caps (🔩x2).

Power On



d190b0029

1. Turn the machine on. The machine will ask you to wait while it changes the settings. This may require a few minutes to complete.
2. When the machine tells you the setting changes are finished, touch [OK].



d190b0030

3. Enter the SP mode,.
4. Set System SP **SP5-752-001** Bit 0 to "1".
5. Set Scanner SP **SP1-041-001** Bit 0 to "1"
6. If the fax option is installed, set Fax SP **SP3-301-001** Bit 0 to "1"
7. Cycle the machine off/on. This completes the installation.

Controller Options

Overview

2

This machine has I/F card slots for optional I/F connections and SD card slot applications. After you install an option, check that the machine can recognize it (see “Check All Connections” at the end of this section).

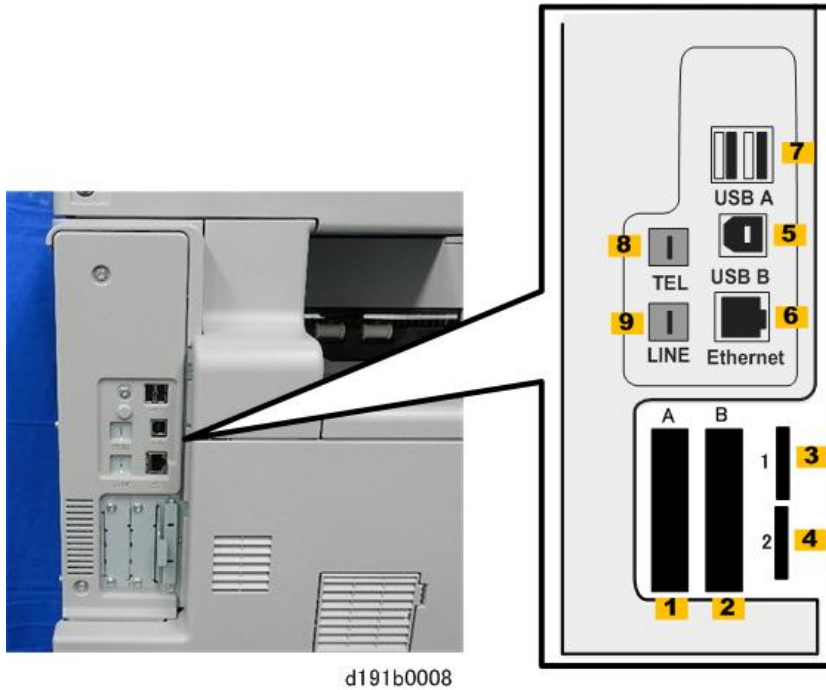

d191b0008

No.	Item	For
1	Slot A	<ul style="list-style-type: none"> File Format Converter Type E (D377-04)
2	Slot B	<ul style="list-style-type: none"> IEEE 802.11 Interface Unit Type O (M417)
3	Slot 1	SD card applications, and installation of: <ul style="list-style-type: none"> Browser Unit Type M10 (D792-03, -04) SD card for NetWare Printing Type M10 (D792-06) XPS Direct Print Option Type M10 (D792-08) Camera Direct Print Card Type M10 (D792-07) DataOverwriteSecurity Unit Type H (D377-22)

No.	Item	For
4	Slot 2	Service slot (firmware update), and installation of: <ul style="list-style-type: none"> OCR Unit Type M2 (D166-25, -26)
5	USB B	<ul style="list-style-type: none"> USB 2.0
6	Ethernet	Network connection
7	USB A	<ul style="list-style-type: none"> Bluetooth Interface Unit Type D (D566)
8	TEL	Fax
9	LINE	Fax

★ Important

- The Bluetooth Interface Unit (USB slot 1/2) and the Wireless LAN (Slot B) are exclusive. Only one can be installed.

⚠ WARNING

- Always turn the machine off and unplug the main machine power cord before you do any procedure in this section.

SD Card Appli Move

Overview

The service program “SD Card Appli Move” (SP5-873) lets you copy application programs from one SD card to another SD card.

Make sure that the target SD card has enough space.

1. Insert the target SD card in Slot 1 (upper).
2. Insert SD card in Slot 2 (lower).
3. Enter SP5873 “SD Card Appli Move”.
4. Then move the application from the SD Card in Slot 2 (lower) to the SD Card in Slot 1 (upper).

↓ Note

- Do steps 1-2 again if you want to move another application program.
5. Exit the SP mode.

Be very careful when you do the SD Card Appli Move procedure:

- The data necessary for authentication is transferred with the application program from an SD card to another SD card. Authentication fails if you try to use the SD card after you copy the application program from one card to another card.
- Do not use the SD card if it has been used before for other purposes. Normal operation is not guaranteed when such an SD card is used.



d191b0009

- Remove the controller faceplate cover (🔩 x 3).
- After you move an application from the original card to to another SD card, attach the original card to the back of the cover and then re-attach it.

Note

- The original cards should be stored because they are the only proof that the user is licensed to use the application program. You may need to check an SD card and its data to solve a problem in the future.

Move Exec

The menu "Move Exec" (SP5-873-001) lets you copy application programs from the original SD card to another SD card.

★ Important

- **Do not turn ON the write protect switch of the system SD card or application SD card on the machine. If the write protect switch is ON, a download error (e.g. Error Code 44) occurs during a firmware upgrade or application merge.**
1. Turn the main switch off.
 2. Make sure that an SD card is in SD Card Slot 1. The application program is copied to this SD card.
 3. Insert the SD card with the application program in SD Card Slot 2. The application program is copied from this SD card.
 4. Turn the main switch on.
 5. Start the SP mode.
 6. Select SP5-873-001 "Move Exec."
 7. Follow the messages shown on the operation panel.
 8. Turn the main switch off.
 9. Remove the SD card from SD Card Slot 2.
 10. Turn the main switch on.
 11. Check that the application programs run normally.

Undo Exec

"Undo Exec" (SP5-873-002) lets you copy back application programs from an SD card to the original SD card. You can use this program when, for example, you have mistakenly copied some programs by using Move Exec (SP5-873-001).

★ Important

- **Do not turn ON the write protect switch of the system SD card or application SD card on the machine. If the write protect switch is ON, a download error (e.g. Error Code 44) occurs during a firmware upgrade or application merge.**
1. Turn the main switch off.
 2. Insert the original SD card in SD Card Slot 2. The application program is copied back into this card.
 3. Insert the SD card with the application program in SD Card Slot 1. The application program is copied back from this SD card.
 4. Turn the main switch on.
 5. Start the SP mode.
 6. Select SP5-873-002 "Undo Exec."
 7. Follow the messages shown on the operation panel.
 8. Turn the main switch off.

9. Remove the SD card from SD Card Slot 2.

Note

- This step assumes that the application programs in the SD card are used by the machine.

10. Turn the main switch on.

11. Check that the application programs run normally.

12. Make sure that the machine can recognize the option (see 'Check All Connections' at the end of this section).

File Format Converter Type E (D377-04)

Accessories

Check the quantity and condition of the accessories in the box against the following list.

No.	Description	Qty
1	File Format Converter PCB	1

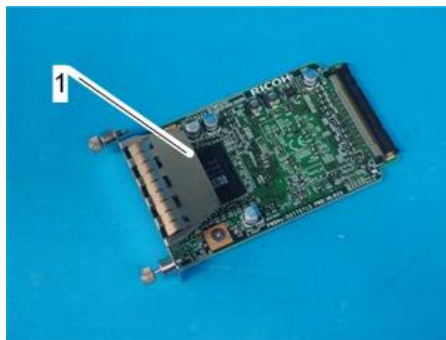

d191z5004

Installation

CAUTION

- Unplug the main machine power cord before you do the following procedure.



d191b0031

1. Remove the slot A cover [A] (x 2).



d191z5005

2. Slide the board in, and then tighten the screws with your fingers.

★ Important

- To avoid twisting or warping the board in its rails or at the connection point, do not tighten the knob screws with a screwdriver.

3. Plug in and turn on the main power switch.
4. Check or set the following SP codes with the values shown below.

SP No.	Title	Setting
SP5-836-001	Capture Function (0:Off 1:On)	"1"
SP5-836-002	Panel Setting	"0"

5. Check the operation.
6. Make sure that the machine can recognize the option (see 'Check All Connections' at the end of this section).

IEEE 802.11 Interface Unit Type O (M417)

2

Accessories

Check the quantity and condition of the accessories in the box against the following list and diagram.

No	Description	Q'ty
1	IEEE802.11a/b/g/n Board (Wireless LAN)	1

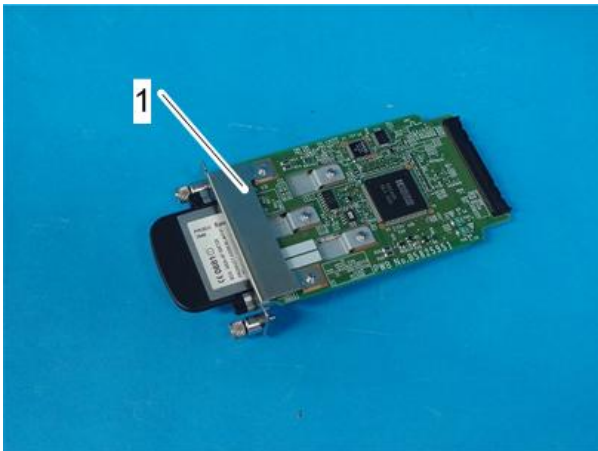

d191z5006

Installation

CAUTION

- Unplug the main machine power cord before you do the following procedure.

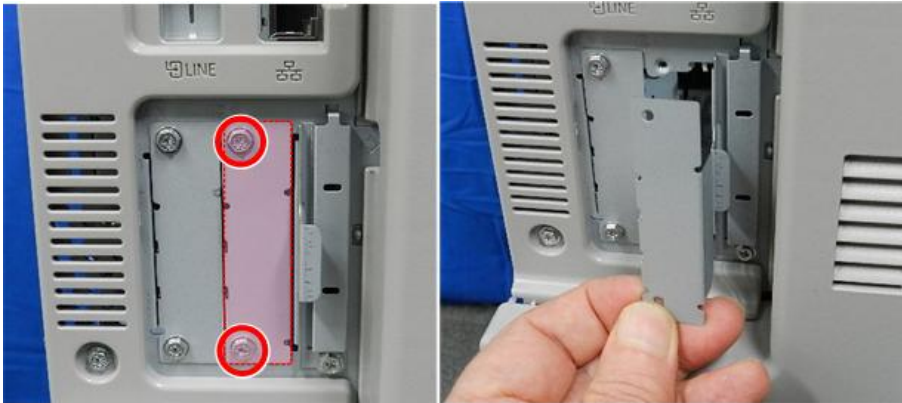

d191b0029

1. Remove the cover of Slot B (⚙ x 2).



d191z5007

2. Insert the Wireless LAN board into Slot B.
3. Tighten the screws with your fingers.

★ Important

- To avoid twisting or warping the board in its rails or at the connection point, do not tighten the knob screws with a screwdriver.
4. Make sure that the machine can recognize the option (see 'Check All Connections' at the end of this section).
 5. Configure the settings of the Wireless LAN referring to the Instruction Sheet provided in the option box.

Browser Unit Type M10 (D792-03, -04)

Installation Procedure

CAUTION

- Unplug the main machine power cord before you do the following procedure.

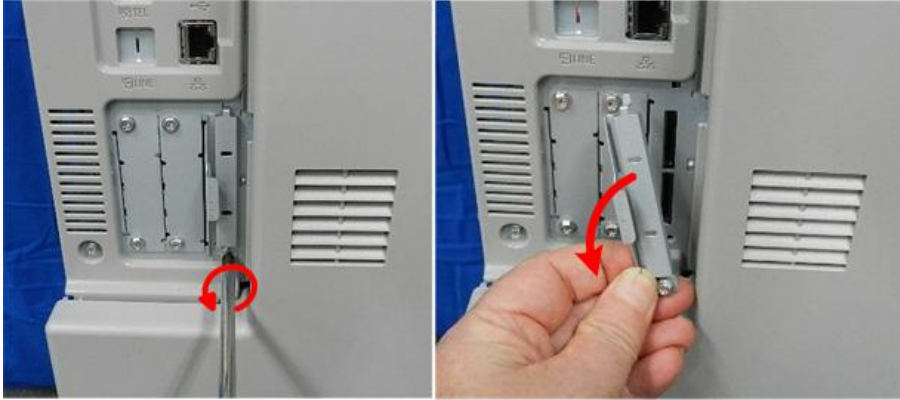

d191b0007

- ~~1. Enter the SP mode, and then check if the setting of SP5-880-001 is~~ [RTB 50](#)
2. Remove the SD card slot cover (x1).
3. Turn the SD-card label face to the rear of the machine. Then push it slowly into slot 2 until you hear a click.
4. Plug in and turn on the main power switch.
5. Push the "User Tools" key.
 - If an administrator setting is registered for the machine, step 4 and 5 are required. Otherwise, skip to step 6.
6. Push the "Login/ Logout" key.
7. Login with the administrator user name and password.
8. Touch "Extended Feature Settings" twice on the LCD.
9. Touch "Install" on the LCD.
10. Touch "SD Card".
11. Touch the "Browser" line.
12. Under "Install to" touch "Machine HDD" and touch "Next".
13. When you see "Ready to Install", check the information on the screen to confirm your previous selection.
14. Touch "OK". You will see "Installing the extended feature... Please wait.", and then "Completed".

15. Touch "Exit" to go back to the setting screen.
16. Touch "Change Allocation".
17. Touch the "Browser" line.
18. Press the hard key that you want to use for the Browser Unit. As a default, this function is assigned to the "Other Functions" key (the bottom key of the function keys).
19. Touch "OK".
20. Touch "Exit" twice to go back to the copy screen.
21. Turn off the main power switch.
22. Install the key for "Browser Unit" to the place where you want.
23. Remove the SD card from slot 2.
24. Attach the slot cover (🔑 x 1).
25. Keep the SD card in the place (see "SD Card Appli Move" in section of "Installation") after you install the application program from the card to HDD. This is because: The SD card can be the only proof that the user is licensed to use the application program. You may need to check the SD card and its data to solve a problem in the future.

Do the following steps if the customer is using the Ricoh JavaScript connected to a Web application developed by Operius/RiDP.

1. Turn the main switch ON.
2. Press the "User Tools/Counter" key.
3. On the touch panel, touch "Browser Features".
4. Touch "JavaScript".
5. Change the Extended JavaScript setting to "Active".

Browser/EXJS Firmware Update Procedure

Note

- The firmware configuration of the Browser Unit Type M10 has been changed to enhance browsing.
 - The Browser Unit Type M10 consists of the Browser firmware and EXJS firmware. The EXJS firmware is equivalent to the existing browser firmware. Therefore, it is possible to update the EXJS firmware using the same procedure as that of SDK application firmware.
1. Turn the main switch ON.
 2. Press the "User Tools/Counter" key.
 3. On the touch panel, touch "Extended Feature Settings".

4. Touch "Extended Feature Settings" in the Extended Feature Settings Menu.
5. Disable "Extended JS" in the Startup Settings tab.
6. Turn the main switch OFF.

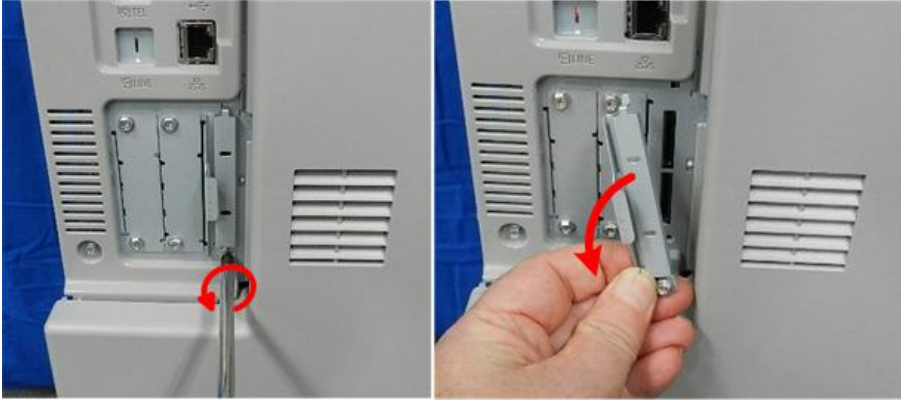

d191b0007

7. Remove the SD-card slot cover from the SD Card slots (🔑 x 1).
8. Insert the SD card for Browser firmware update into SD slot 2 (lower) with its label face towards the front of the machine. Then push it slowly into SD slot 2 (lower) until you hear a click.

↓ **Note**

- Make sure that only the Browser firmware is on this SD card; do not copy the EXJS firmware.

9. Turn the main switch ON.
10. After the Update screen is displayed, select the "Browser".
11. Touch "Update (#)".
12. After the "Update Done" message appears on the screen, turn the main power switch OFF.
13. Remove the SD card from the lower slot.

Do the following steps if you are updating the Extended JavaScript (EXJS).

14. Insert the SD card for EXJS firmware update into SD slot 2 (lower) with its label face towards the front of the machine. Then push it slowly into SD slot 2 (lower) until you hear a click.

↓ **Note**

- Make sure that only the EXJS firmware is on this SD card; do not copy the Browser firmware.

15. Turn the main switch ON.
16. Press the "User Tools/Counter" key.
17. On the touch panel, touch "Extended Feature Settings".
18. Touch "Extended Feature Settings" in the Extended Feature Settings Menu.
19. Change the status of "Extended JS" to "Ending" in the Startup Settings tab.

20. Turn the main switch OFF.
21. Insert the SD card containing the Extended JS firmware into the lower slot.
22. Turn the main switch ON.
23. Press the "User Tools/Counter" key.
24. On the touch panel, push "Extended Feature Settings".
25. Touch "Extended Feature Settings" in the Extended Feature Settings Menu.
26. Touch the "Install" tab.
27. Touch "SD card", then select "Extended JS" from the list of Extended Features.
28. Select "Machine HDD" as the "Install to" destination, then touch "Next".
29. Check the Extended Features information on the "Ready to Install" screen, then press "OK".
30. After "The following extended feature has already been installed. Are you sure you want to overwrite it?" is displayed, press "Yes".
31. Change the status of Extended JS to "waiting" in the Startup Settings tab.
32. Turn the main switch OFF.
33. Remove the SD card from slot 2 (lower slot) and attach the SD-card slot cover.
34. Turn the main switch ON.
35. Press the "User Tools/Counter" key.
36. On the touch panel, touch "Extended Feature Settings".
37. Touch "Extended Feature Settings" in the Extended Feature Settings Menu.
38. Make sure that the "Extended JS" has been updated to the latest version in the Startup Settings tab.

Note

- If you are not updating the EXJS Firmware, attach the SD-card slot cover after step 13.

EXJS Firmware Un-install Procedure

1. Turn the main switch ON.
2. Press the "User Tools/Counter" key.
3. Login with an administrator user name and password.
4. On the touch panel, touch "Extended Feature Settings".
5. Touch "Extended Feature Settings" in the Extended Feature Settings Menu.
6. Touch "Uninstall".
7. Touch "Extended JS", and then touch "Yes" after "Are you sure you want to uninstall the following extended feature?" is displayed.

↓ **Note**

- "Uninstalling the extended feature... Please wait" is then displayed on the touch screen.

8. After "Completed" is displayed, turn the main power switch OFF.

↓ **Note**

- The Browser firmware is un-installed from the machine when the Browser SD card is removed.

IC Card Reader

1. ARDF rear cover (see page 384)

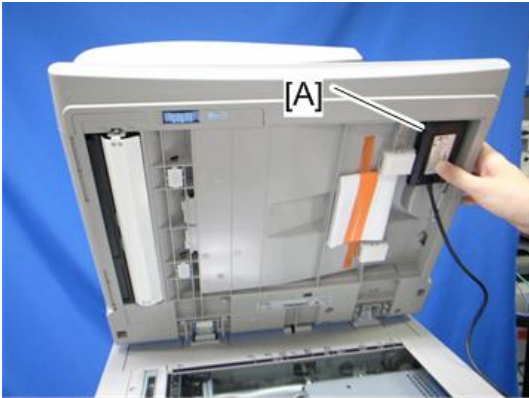

m022i136a

2. Attach the IC card reader [A].

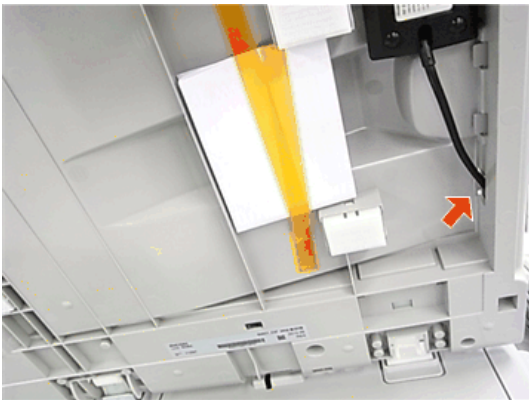

m022i544

3. Release the hook, and then put the cable outside.

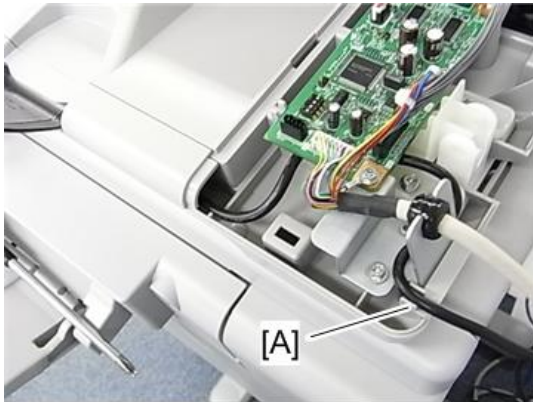

m022i545

4. Route the cable [A] as shown above.

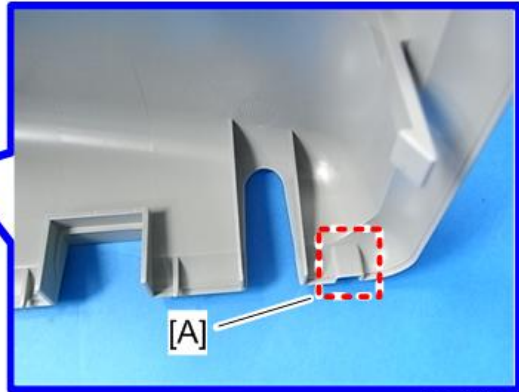
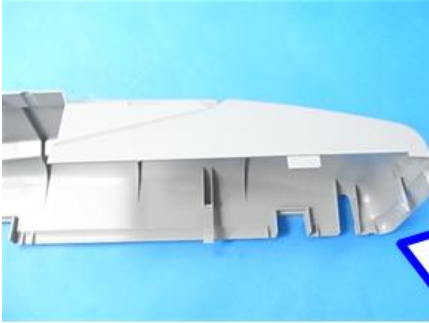

m022i546

5. Remove the part [A] of the ARDF rear cover with nippers or a similar tool.
6. Reassemble the machine.



7. Attach the location decal to the front-right on the ARDF.

Bluetooth Interface Unit Type D (D566)

Accessories

Check the quantity and condition of the accessories in the box against the following list and diagram.

No.	Description	Qty
1	Bluetooth Interface	1
2	CD-ROM 1	1

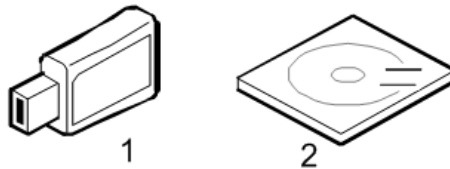

d191b0064

Installation

⚠ WARNING

- Unplug the main machine power cord before you do the following procedure.
- Turn off the power of the main unit when connecting the Bluetooth unit. Do not attach or remove the Bluetooth unit while the power of the main unit is turned on.

⚠ CAUTION

- To prevent damage to the controller box, always work carefully.
- Never put your hand or a tool into the box when you remove the controller box or install an option.
- To prevent damage to the circuits on the boards, always touch a metal surface to discharge static charge from your hands before you handle a board.

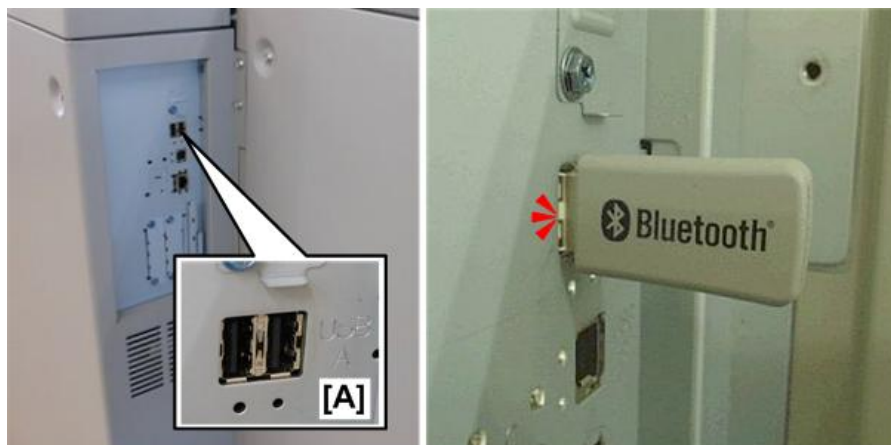

d191b0065

1. Insert the Bluetooth unit into either USB Host Interface socket [A].
2. Make sure that the machine recognizes the option:
[User Tools] > Printer Features > List/Test Print > Configuration Page

Camera Direct Print Card Type M10 (D792-07)

Check the quantity and condition of the accessories in the box against the following list and diagram.

No.	Description	Qty
1	Camera Direct Print SD Card	1
2	Decal	1

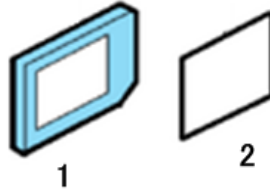

d191b0066

Installation

Unplug the main machine power cord before you do the following procedure.

1. Remove the SD card slot cover (1 x 1).
2. Slowly, insert the Camera Direct Print SD card in Slot 1 with its label face towards the front of the machine.
3. Turn on the machine.
4. Make sure that the machine recognizes the option:
[User Tools] > Printer Features > List/Test Print > Configuration Page

XPS Direct Print Option Type M10 (D792-08)

Check the quantity and condition of the accessories in the box against the following list and diagram.

No.	Description	Qty
1	XPS Direct Print SD Card	1
2	Decal	1

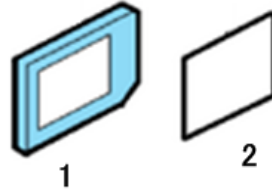

d191b0066

2

Installation

Unplug the main machine power cord before you do the following procedure.

1. Remove the SD card slot cover (1 x 1).
2. Slowly, insert the XPS SD card in Slot 1 with its label face towards the front of the machine.
 - Perform the SD Card Appli Move if necessary. (See "SD Card Appli Move" at the end of this section.)
3. Turn on the machine.
4. Make sure that the machine recognizes the option:
[User Tools] > Printer Features > List/Test Print > Configuration Page

SD card for NetWare printing Type M10 (D792-06)

Accessories

Check the quantity and condition of the accessories in the box against the following list.

No.	Description	Qty
1	Netware SD Card	1



d191b0067

Installation

WARNING

- Unplug the main machine power cord before you do the following procedure.
- 1. Remove the SD card slot cover (1 x1).
- 2. Insert the SD card for NetWare printing Slot 1 with its label facing the front of the machine.
 - Perform SD Card Appli Move if necessary. (See “SD Card Appli Move” at the end of this section.)
- 3. Turn on the machine
- 4. Make sure that the machine can recognize the option:
[User Tools] > Printer Features > List/Test Print > Configuration

OCR Unit Type M2 (D166-25, -26)

What is Searchable PDF?

Searchable PDF embeds the text information in the scanned document without processing the data on a computer.

- If this option is installed:
 1. You can search the text in the scanned document.
 2. You can add extra text to the file name.
 3. The orientation of the originals is detected, and the document is automatically rotated.
- The OCR unit is provided on an SD card. By installing the SD card on the main machine, a function key is added to the operation panel. The OCR application does not need to be installed on the computer.
- After OCR installation, you can specify the settings of the searchable PDF function.

- The machine embeds the text information of the scanned document after scanning the originals (after the originals are ejected from the ADF). Therefore, you can remove the originals from the exposure glass or ADF.
- You can use other applications such as copy and printer while the machine embeds the text information of the scanned document.

Accessories

2

Check the quantity and condition of the accessories in the box against the following list.

No.	Description	Qty
1	OCR SD Card	1

Installation

WARNING

- Unplug the main machine power cord before you do the following procedure.
1. Remove the SD card slot cover (1 x 1).
 2. Insert the OCR SD card in Slot 2 with its label facing the front of the machine.
 3. Turn on the machine.
 4. Go into the SP mode and do SP5-878-004.
 - This records the content of the SD card in NVRAM
 - The machine ID of the main machine is recorded on the SD card.
 5. When the display tells you that the execution is completed, touch [Exit].
 - If the machine returns the “Failed” alert, check if the SD card to determine if it has already been used.
 - Turn off the machine and then Steps 1 to 5 again.
 6. Cycle the machine off/on.
 7. Go in the SP mode and do SP5-878-004 (Option Setup: OCR) and then press [EXECUTE]. The OCR dictionary is copied to the HDD from the SD card.
 - In the first execution, the SD card and the machine are linked.
 - In the second execution, the OCR dictionary is copied onto the HDD.
 8. Turn off the machine, and then remove the SD card.

Important

- **Store the SC card behind the cover of the controller faceplate. You will need the original SD card in case the HDD unit ever fails.**

9. Turn on the main power switch.

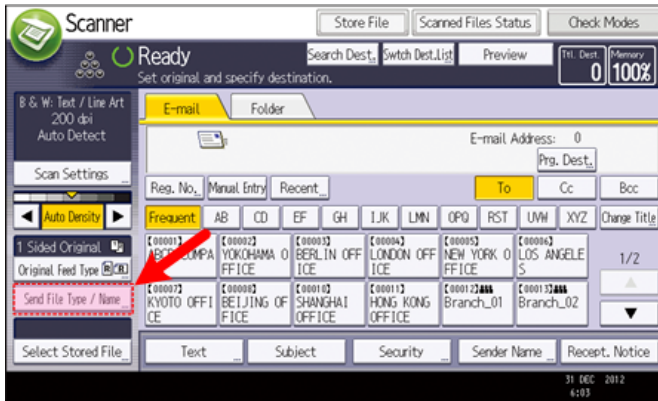

d191b0068

10. On the "Scanner" screen touch [Send File Type / Name].

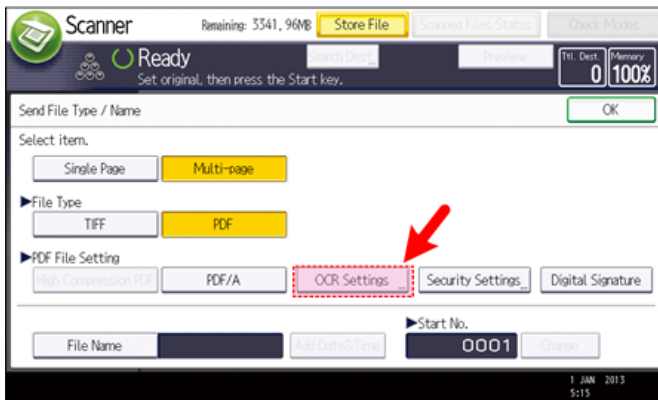

d191b0069

11. Check to see if [OCR Settings] is displayed on the [Send File Type / Name] screen.

- The searchable PDF function can be switched on/off on the [OCR Settings] screen after installing the OCR unit.
- If you want to use the searchable PDF function, select [On] for [OCR Settings]. (Default: [Off])

Restoration

After installation of the OCR Unit:

- The searchable PDF function is saved on the HDD and the SD card ID is saved in NVRAM.
- After replacement of either the HDD unit or the NVRAM, OCR Unit Type M2 must be installed again.

When the original SD card exists

- **If you replace the HDD.**

Re-install the OCR Unit Type M2 from the original SD card.

- **If you replace the NVRAM.**

If you upload / download the NVRAM data, re-install the OCR Unit Type M2 from the original SD card. If you do not upload / download the NVRAM data, order a new SD card (service part) of the OCR Unit Type M2. Then re-install the OCR Unit Type M2 from the new SD card.

- **When you replace the HDD and NVRAM at the same time.**

Re-install the OCR Unit Type M2 from the original SD card.

If Original SD Card is Lost

- Order a new SD card (service part) of the OCR Unit Type M2, and then re-install from the new SD card.
- When you re-install the OCR Unit Type M2, do the same procedure as the original installation procedure.

DataOverwriteSecurity Unit Type H (D377-22)

Overview

This option should be installed only for the customer who requires the **CC certified Data Overwrite Security function**.

The function of this option is completely the same as the Data Overwrite Security in Security Functions, which is standard on this machine. (Security Function Installation)

Component List

Check the quantity and condition of the accessories in the box against the following list.

No.	Description	Q'ty
1.	SD Card	1

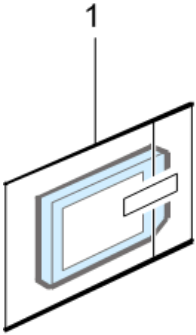

d1351921

Installation Procedure

1. Remove the SD-card slot cover [A] from the SD Card slots (🔧 x 1).
2. Insert the SD card (DataOverwriteSecurity Unit) in SD slot 1 (upper) [A] with its label face towards the front of the machine. Then push it slowly into SD slot 1 (upper) until you hear a click.
3. Install the application using SP5-878-001.

Check All Connections

1. Plug in the power cord. Then turn on the main switch.
2. Enter the printer user mode. Then print the configuration page.
User Tools > Printer Settings > List Test Print > Config. Page

All installed options are shown in the "System Reference" column.

3. Preventive Maintenance

Maintenance Tables

See "Appendices" for the following information:

- Maintenance Tables

PM Parts Settings

Before Removing the Old PM Parts

1. Enter the SP mode.
2. Output the SMC logging data with SP5-990-004.
3. Set the following SPs to "1" before you turn the power off. Then, the machine will reset the PM counters automatically. In the case of developer, the developer initialization will also be done automatically.
4. Exit the SP mode.

3

Item	SP
Development unit	Black: 3902-001 Cyan: 3902-002 Magenta: 3902-003 Yellow: 3902-004
PCU	Black: 3902-009 Cyan: 3902-0010 Magenta: 3902-011 Yellow: 3902-012
Fusing unit	3902-014
Fusing roller	3902-015
Fusing belt	3902-016
Image Transfer Belt Unit	3902-013
Image Transfer Belt Cleaning Unit	3902-017
Paper Transfer Roller Unit	3902-018
Waste Toner Bottle (if not full or near-full)	3902-020
ADF Pickup Roller	3902-206
ADF Feed Roller	3902-207
ADF Friction Pad	3902-208

For the following units, there is a new unit detection mechanism. It is not necessary to reset PM counters.

- PCDU
- Image Transfer Belt Unit
- Fusing unit
- Waste Toner Bottle (if full or near full)

After installing the new PM parts

3

1. Turn on the main power switch.
2. Output the SMC logging data with SP5-990-004 and check the counter values.
3. Make sure that the PM counters for the replaced units are "0" with SP7-803. If the PM counter for a unit was not reset, then reset that counter with SP 7-804.
4. Make sure that the exchange counter counts up with SP7-853.
5. Make sure that the counters for the previous units (SP7-906) on the new SMC logging data list (from step 2 above) are equal to the counters (SP7-803) for these units on the previous SMC logging data list (the list that was output in the "Before removing the old parts" section).
6. Make sure that the unit replacement date is updated with SP7-950.

Preparation before operation check

1. Clean the exposure glasses (for DF and book scanning).
2. Enter the user tools mode.
3. Do the "Automatic Color Calibration(ACC)" for the copier mode & printer mode as follows:
 - Print the ACC test pattern (User Tools > Maintenance > ACC > Start).
 - Put the printout on the exposure glass.
 - Put 10 sheets of white paper on the test chart. This ensures the precise ACC adjustment.
 - Close the ARDF or the platen cover.
 - Press "Start Scanning" on the LCD. Then, the machine starts the ACC.
4. Exit the User Tools mode, and then enter the SP mode.
5. Do the "Forced line position adjustment" as follows.
 - First do SP2-111-3 (Mode c).
 - Then do SP2-111-1 (Mode a).
 - To check if SP 2-111-1 was successful, watch the screen during the process. A message is displayed at the end. Also, you can check the result with SP 2-194-10 to -12.
6. Exit the SP mode.

Operation check

Check if the sample image has been copied normally.

4. Replacement and Adjustment

Notes on the Main Power Switch

Push Switch

The main power button of this machine has been changed to a push-button switch (push button) from the conventional rocker switch. The push switch has characteristics and specifications different from the rocker switch. Care must be taken when replacing and adjusting parts.

Characteristics of the Push Switch (DC Switch)

Power is supplied to the machine even when the main power switch is turned OFF.

The push switch in this machine uses DC (direct current). Therefore, if the AC power cord is connected to an electrical outlet, power is supplied to the controller board, the operation unit and other modules even when the main power is turned OFF. When replacing the controller board and the operation unit in this state, not only these boards, it will damage other electrical components.

So, when performing maintenance work such as replacing parts, in addition to turning off the main power with the push switch, always unplug the AC power cord.

When you disconnect the power cord from the AC wall outlet, inside the machine there is still residual charge.

When you disconnect the power cord from the AC wall outlet, inside the machine for a while there is still residual charge. Therefore, if you remove boards in this state, it can cause a blown fuse or memory failure.

- How to remove the residual charge inside the machine

After you unplug the power cord from the AC wall outlet, in order to remove the residual charge from inside the machine, be sure to press the main power switch. Thus, the charge remaining in the machine is released, and it is possible to remove boards.

When you reconnect the AC power cord into an AC wall outlet, the machine will start automatically.

In order to remove the residual charge, push the main power switch while you disconnect the AC power cord. At that time, the power ON flag inside the machine is set. Therefore, after you finish work on the machine and reconnect the power cord to the AC, even if you do not press the main power switch, the machine will start automatically and the moving parts will begin to move. When working on moving parts, be careful that fingers or clothes do not get caught.

Note

- Automatic restart deals with cases when you accidentally unplugged the AC power cord or unexpected power outages. By keeping the power flag ON, after the resumption of power, the machine will start up automatically.

In rare cases, when you reconnect the AC power cord to a power outlet, the machine does not start automatically. In this case, the machine has not failed. The cause is due to the timing of releasing the residual charge. If you press the main power switch while the residual charge was already released, the power ON flag will not be set. At this time, start the machine manually by pressing the main power switch.

Shutdown Method

4



d191b0075

1. Press the main power switch on the machine.
2. The shutdown message is displayed. Wait for 2 minutes for the machine to shut down.

Note

- After the shutdown process completes, the main power is turned off automatically.

CAUTION

- Before you remove any covers allow the machine to sit for a few minutes so the residual charge on boards can dissipate.

Forced Shutdown

In case normal shutdown does not complete for some reason, the machine has a forced shutdown function.

To make a forced shutdown, press and hold the main power switch for 6 seconds.

In general, do not use the forced shutdown.

 **Important**

- **Forced shutdown may damage the hard disk and memory, and can cause damage to the machine. Use a forced shutdown only if it is unavoidable.**

Beforehand

CAUTION

- Before installing options, please do the following:
- If there is a fax unit in the machine, print out all messages stored in the memory, the lists of user-programmed items, and the system parameter list.
- If there are printer jobs in the machine, print out all jobs in the printer buffer.
- Turn off the main switch and disconnect the power cord, the telephone line, and the network cable.

Important

- **Always touch a grounded surface to discharge static electricity from your hands before you handle SD cards, printed circuit boards, or memory boards.**

Note

- Before you start to remove components from the machine, turn off the main power switch, check that the shutdown process has finished, then unplug the machine.
- After the main power switch of the machine has been turned off, the PSU keeps the power supply to the controller until the HDD unit has been shutdown safely.

Special Tools

Part Number	Description	Q'ty
B645 5010	SD Card (128MB)	1
B645 5020	SD Card (1GB)	1
C401 9503	20X Magnification Scope	1
A257 9300	Grease Barrierta – S552R	1
5203 9502	Silicone Grease G-501	1
D015 9500	G104 Yellow Toner	1
A184 9501	Optics Adjustment Tool (2 pcs/set)	1
A092 9503	C4 Color Test Chart	1

↓ Note

- A PC (Personal Computer) is required for creating the Encryption key file to the controller board (encryption function) when replacing the controller board for a model in which HDD encryption has been enabled.

Image Adjustment

Scanning

Check the printing registration/side-to-side adjustment and the blank margin adjustment before you do the following scanner adjustments.

Note

- Use C-4 test chart to do the following adjustments.

4

Scanner sub-scan magnification

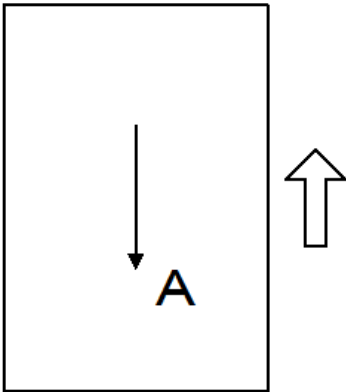

A: Sub-scan magnification

1. Put the test chart on the exposure glass. Then make a copy from one of the feed stations.
2. Check the magnification ratio. Adjust with SP4-008 if necessary.
Standard: $\pm 1.0\%$.

Scanner leading edge and side-to-side registration

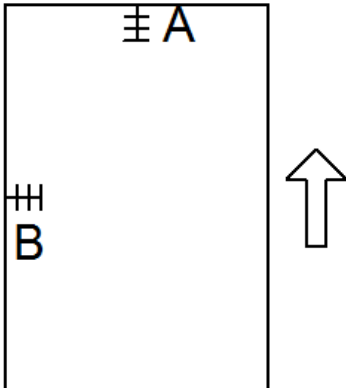

4

A: Leading Edge Registration

1. Put the test chart on the exposure glass. Then make a copy from one of the feed stations.
2. Check the leading edge and side-to-side registration. Adjust the following SP modes if necessary.
Standard: $0 \pm 2\text{mm}$ for the leading edge registration, $0 \pm 2.5\text{mm}$ for the side-to-side registration.

	SP mode
Leading Edge Registration	SP4-010-001
Side-to-Side Registration	SP4-011-001

ARDF

ARDF side-to-side, leading edge registration and trailing edge

Use A4/LT paper to make a temporary test chart as shown above.

1. Put the temporary test chart on the ARDF. Then make a copy from one of the feed stations.
2. Check the registration. Check the leading edge and side-to-side registration. Adjust the following SP modes if necessary.

Standard: $4.2 \pm 2\text{ mm}$ for the leading edge registration, $2 \pm 1\text{ mm}$ for the side-to-side registration.
Use the following SP modes to adjust if necessary.

SP Code	What It Does	Adjustment Range
SP6-006-001	Side-to-Side Regist: 1st	$\pm 3.0\text{ mm}$
SP6-006-003	Leading Edge Registration	$\pm 5.0\text{ mm}$

SP Code	What It Does	Adjustment Range
SP6-006-006	Buckle: Duplex 2nd	± 5 mm
SP6-006-007	Rear Edge Erase (Trailing Edge)	± 5 mm

ARDF sub-scan magnification

- Put the temporary test chart on the ARDF. Then make a copy from one of the feed stations.
- Check the magnification ratio. Adjust with SP6-017-001 if necessary.
 - Standard: ±5.0%
 - Reduction mode: ±1.0%
 - Enlargement mode: ±1.0%

4

Registration

Image Area

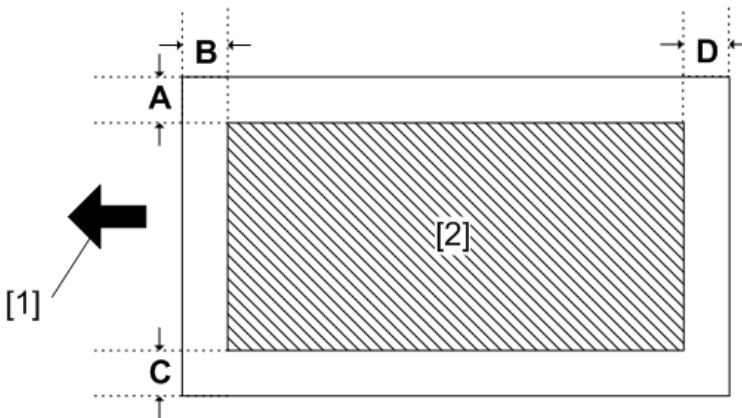

- [1]: Feed direction, [2]: Image area

A = C = 2.0 mm, B = D = 4.2 mm

Make sure that the registration is adjusted within the adjustment standard range as shown below.

Leading Edge

Adjusts the leading edge registration for each paper type and process line speed.

Side to Side

Adjusts the side-to-side registration for each paper feed station. Use SP mode (SP1-002) to adjust the side-to-side registration for the optional paper feed unit and duplex unit.

Adjustment Standard

- Leading edge (sub-scan direction): 4.2 ± 1.5 mm
- Trailing edge (sub-scan direction): 4.2 ± 2.7 mm
- Side to side (main-scan direction): 2 ± 1.5 mm

Paper Registration Standard



The registration in both main- and sub-scan directions can change within the following tolerance.

- Sub-scan direction: 0 ± 2 mm
- Main-scan direction: 0 ± 2 mm

Adjustment Procedure

1. Enter SP2-109-003.
2. Print out the test pattern (14: 1-dot trimming pattern) with SP2-109-003.

Note

- Registration can change slightly as shown on the previous page. Print some pages of the 1-dot trimming pattern for step 3 and 4. Then average the leading edge and side-to-side registration values, and adjust each SP mode.
3. Do the leading edge registration adjustment.
 - 1) Check the leading edge registration and adjust it with SP1-001.
 - 2) Select the adjustment conditions (paper type and process line speed).
 - 3) Input the value. Then press the  key.
 - 4) Generate a trim pattern to check the leading edge adjustment.
 4. Do the side-to-side registration adjustment.
 - 1) Check the side-to-side registration and adjust it with SP1-002.
 - 2) Select the adjustment conditions (paper feed station).
 - 3) Input the value. Then press the  key.
 - 4) Generate a trim pattern to check the leading edge adjustment.

Erase Margin Adjustment

Note

- Adjust the erase margin C and D only if the registration (main scan and sub scan) cannot be adjusted within the standard values. Do the registration adjustment after adjusting the erase margin C and D, and then adjust the erase margin A and B.

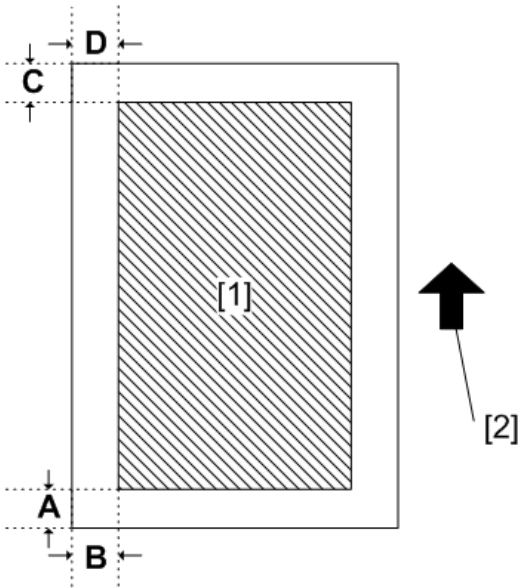

- [1]: Image area, [2]: Feed direction

- Enter SP2-109-003.
- Print out the test pattern (14: 1-dot trimming pattern) with SP2-109-003.
- Check the erase margin A and B. Adjust them with SP2-103-001 to -004 if necessary.
 - Leading edge: 0.0 to 9.9 mm (default: 4.2 mm)
 - Side-to-side: 0.0 to 9.9 mm (default: 2.0 mm)
 - Trailing edge: 0.0 to 9.9 mm (default: 4.2 mm)

Color Registration

Line Position Adjustment

The automatic line position adjustment usually is done for a specified condition to get the best color prints.

Do the following if color registration shifts:

- Do "Auto Color Registration" as follows to do the forced line position adjustment.

1. First do SP2-1111-3.
2. Then do SP2-1111-1.

To check if SP 2-1111-1 was successful, watch the screen during the process. A message is displayed at the end. Also, you can check the result with SP 2-194-10 to -12.

- You should also do the line position adjustment at these times:
 - After you transport or move the machine (you should do the forced line position adjustment if you install the machine at the user location.) if the machine is pre-installed at the workshop and moved to the user location,
 - When you open the drum positioning plate
 - When you remove or replace the motors, clutches, and/or gears related to the drum/development/transfer sections
 - When you remove or replace the image transfer belt, image transfer belt unit or laser optical housing unit

Printer Gamma Correction

↓ Note

- The ACC is usually sufficient to adjust the color balance to get the best print output. You only need the printer gamma correction to fine-tune to meet user requirements.

Use SP modes if you want to modify the printer gamma curve created with ACC. You can adjust the gamma data for the following:

- Highlight
- Middle
- Shadow areas
- IDmax.

The adjustable range is from 0 to 30 (31 steps).

Copy Mode

- KCMY Color Balance Adjustment -

The adjustment uses only "Offset" values.

↓ Note

- Never change "Option" values (default value is 0).

Highlight (Low ID)	Levels 2 through 5 in the C4 chart 10-level scale
--------------------	---

Middle (Middle ID)	Levels 3 through 7 in the C4 chart 10-level scale
Shadow (High ID)	Levels 6 through 9 in the C4 chart 10-level scale
ID max	Level 10 in the C4 chart 10-level scale (affects the entire image density.)
Offset	The higher the number in the range associated with the low ID, middle ID, high ID, and ID max, the greater the density.

There are four adjustable modes (can be adjusted with SP4-918-009):

- Copy Photo mode
- Copy Letter mode
- Copy Letter (Single Color) mode
- Copy Photo (Single Color) mode

4

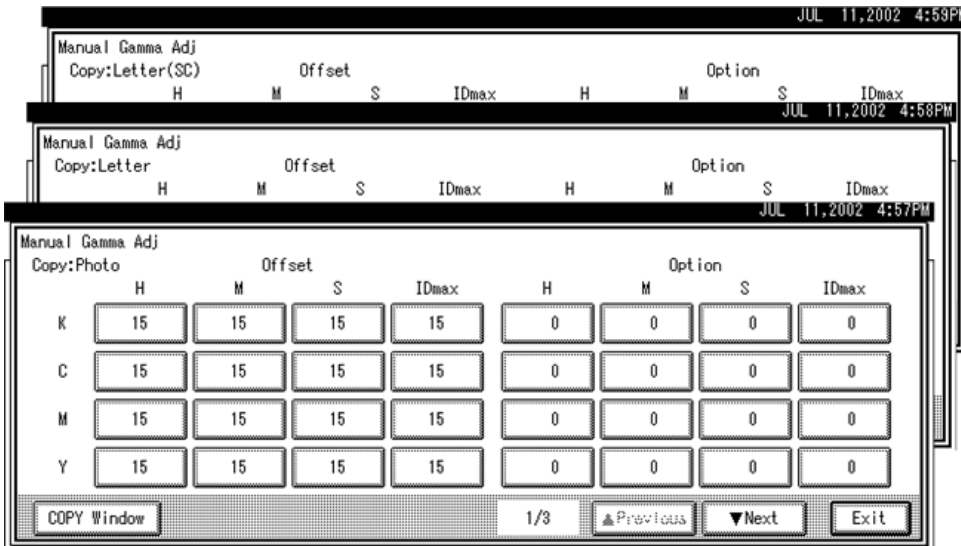

- Adjustment Procedure -

1. Copy the C-4 chart in the mode that you want to adjust.
2. Enter the SP mode.
3. Select "System SP."
4. Select SP4-918-009.
5. Adjust the offset values until the copy quality conforms to the standard (see the table below).

Note

- 1. Never change "Option" value (default value is "0").
- 2. Adjust the density in this order: "ID Max", "Middle", "Shadow", "Highlight".

- Photo Mode, Full Color -

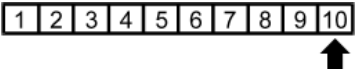
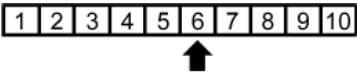
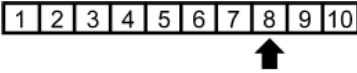
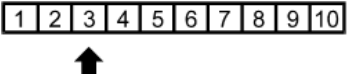
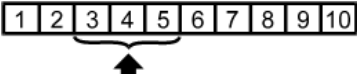
	Item to Adjust	Level on the C-4 chart	Adjustment Standard
1	ID max: (K, C, M, and Y)		Adjust the offset value so that the density of level 10 matches that of level 10 on the C-4 chart.
2	Middle (Middle ID) (K, C, M, and Y)		Adjust the offset value so that the density of level 6 matches that of level 6 on the C-4 chart.
3	Shadow (High ID) (K, C, M, and Y)		Adjust the offset value so that the density of level 8 matches that of level 8 on the C-4 chart.
4	Highlight (Low ID) (K, C, M, and Y)		Adjust the offset value so that dirty background does not show on the copy and the density of level 3 is slightly lighter than that of level 3 on the C-4 chart.
5	K Highlight (Low ID) (C, M, and Y) <on the full color copy>		Adjust the offset value so that the color balance of black scale levels 3 through 5 in the copy is seen as gray (no C, M, or Y should be visible). If the black scale contains C, M, or Y, do steps 1 to 4 again.

4

- Photo Mode, Single Color -

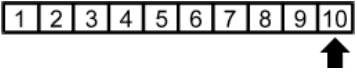
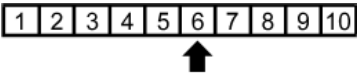
	Item to Adjust	Level on the C-4 chart	Adjustment Standard
1	ID max: (K)		Adjust the offset value so that the density of level 10 matches that of level 10 on the C-4 chart.
2	Middle (Middle ID) (K)		Adjust the offset value so that the density of level 6 matches that of level 6 on the C-4 chart.

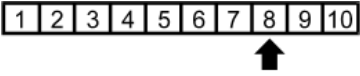
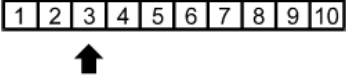
3	Shadow (High ID) (K)		Adjust the offset value so that the density of level 8 matches that of level 8 on the C-4 chart.
4	Highlight (Low ID) (K)		Adjust the offset value so that dirty background does not show on the copy and the density of level 3 is slightly lighter than that of level 3 on the C-4 chart.

- Text (Letter) Mode, Full Color -

4

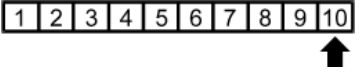
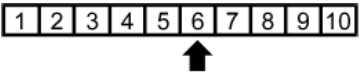
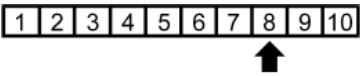
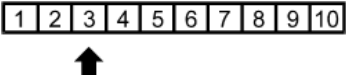
	Item to Adjust	Level on the C-4 chart (K)	Adjustment Standard
1	ID max: (K, C, M, and Y)		Adjust the offset value so that the density of level 10 matches that of level 10 on the C-4 chart.
2	Middle (Middle ID) (K, C, M, and Y)		Adjust the offset value so that the density of level 6 matches that of level 6 on the C-4 chart.
3	Shadow (High ID) (K, C, M, and Y)		Adjust the offset value so that the density of level 8 matches that of level 8 on the C-4 chart.
4	Highlight (Low ID) (K, C, M, and Y)		Adjust the offset value so that dirty background does not show on the copy and the density of level 3 is slightly lighter than that of level 3 on the C-4 chart.

- Text (Letter) Mode, Single Color -

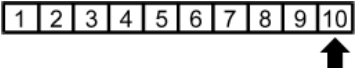
	Item to Adjust	Level on the C-4 chart (K)	Adjustment Standard
1	ID max: (K)		Adjust the offset value so that the density of level 10 matches that of level 10 on the C-4 chart.

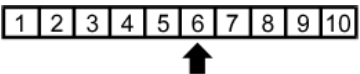
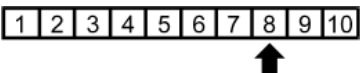
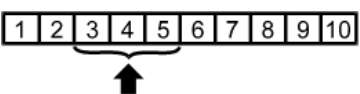
2	Middle (Middle ID) (K)		Adjust the offset value so that the density of level 6 matches that of level 6 on the C-4 chart.
3	Shadow (High ID) (K)		Adjust the offset value so that the density of level 8 matches that of level 8 on the C-4 chart.
4	Highlight (Low ID) (K)		Adjust the offset value so that dirty background does not show on the copy and the density of level 3 is slightly lighter than that of level 3 on the C-4 chart.

↓ Note

- Text parts of the test pattern cannot be printed clearly after you adjust "shadow" as shown above. At this time, check if the 5 line/mm pattern at each corner is printed clearly. If it is not, adjust the offset value of "shadow" again until it is.

Printer Mode

There are six adjustable modes (select these modes with printer SP1-102-001):

- 1200 x 1200 photo mode
- 1200 x 1200 text mode
- 2400 x 600 photo mode
- 2400 x 600 text mode
- 1800 x 600 photo mode
- 1800 x 600 text mode
- 600 x 600 photo mode
- 600 x 600 text mode

	K	C	M	Y
Highlight	SP1-104-1	SP1-104-21	SP1-104-41	SP1-104-61
Shadow	SP1-104-2	SP1-104-22	SP1-104-42	SP1-104-62
Middle	SP1-104-3	SP1-104-23	SP1-104-43	SP1-104-63
IDmax	SP1-104-4	SP1-104-24	SP1-104-44	SP1-104-64

- Adjustment Procedure -

1. Do ACC for the printer mode.
2. Turn the main power off and on.
3. Enter SP mode.
4. Select "Printer SP".
5. Select SP1-102-001. Then select the necessary print mode to adjust.
6. Choose SP1-103-1 to print out a tone control test sheet if you want to examine the image quality for these settings.
7. Adjust the color density with SP1-104. Compare the tone control test sheet with the C4 test chart.

 **Note**

- Adjust the density in this order: "ID Max", "Shadow", "Middle", "Highlight".

8. Use SP1-105-001 to keep the adjusted settings.

Exterior Covers

Front Door

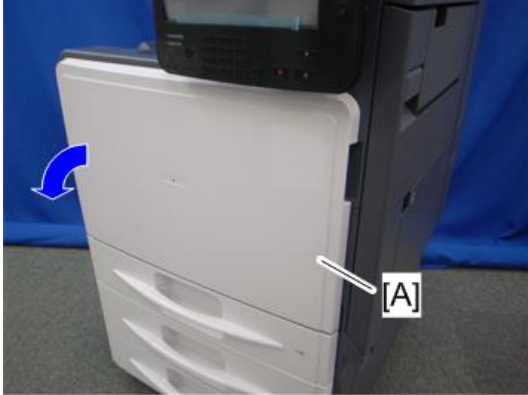

d191b0010

1. Open the front door [A].
2. Toner collection bottle (see page 210)

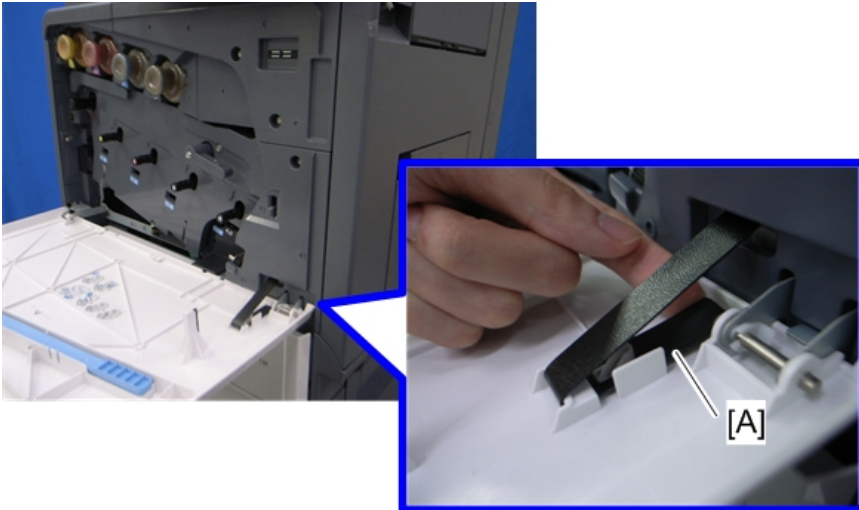

m022r508

3. Release the belt [A].

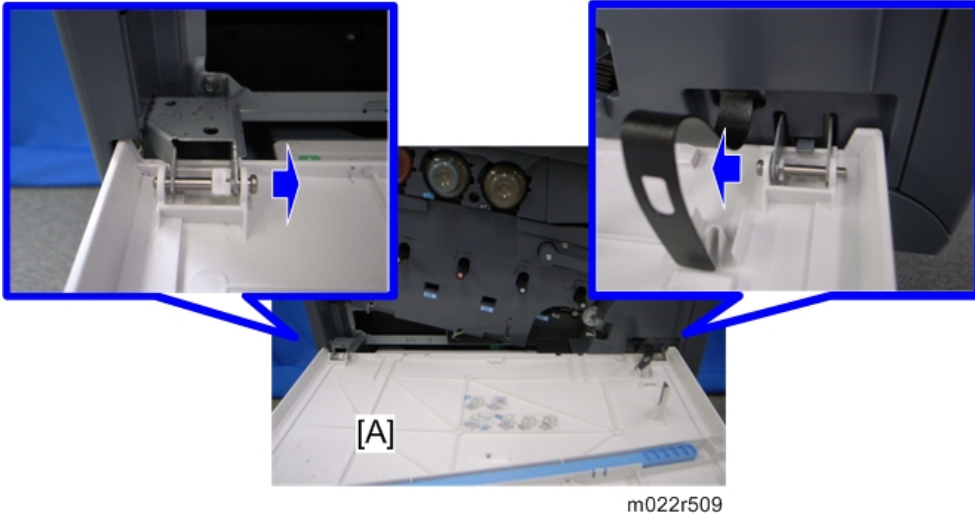

4

4. Front door [A] (⌀ x 2, pin x 2)

Toner Collection Bottle

If you replace a bottle, then you must reset the PM counter for this unit. To do this, set SP-3902-020 to 001 before you start to work on the machine.

1. Open the front door.

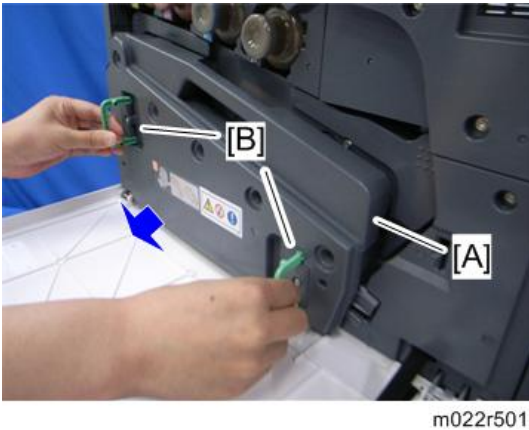

2. Pull out the toner collection bottle [A] while holding the handles [B].

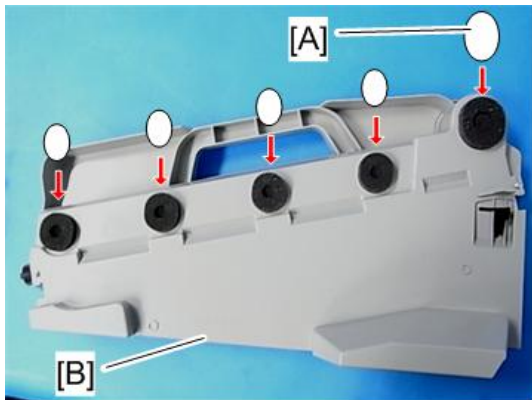

m022r500a

3. Attach the seals (provided with the new toner collection bottle) [A] to the five sponge pads. This closes the toner bottle.
4. Remove the toner collection bottle [B].
5. Put the toner collection bottle [B] into the supplied plastic bag to prevent toner from leaking out of the bottle, and then seal the bag.

4

Left Cover



d191b0022

1. At the rear [A] disconnect the rear edge of the left cover (⚙ x1).
2. At the front [B] open the paper tray.



d191b0023

4

3. Disconnect the front edge of the cover and remove it (⚙️ x 1).

Rear Lower Cover

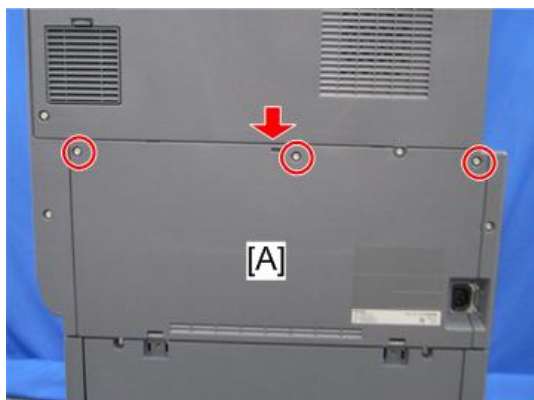

m022r504

1. Rear lower cover [A] (⚙️ x 3, hook x 1)

Rear Cover



d791b0001

1. Rear cover [A] (⚙️ x 5, hooks)

4

Dust Filter

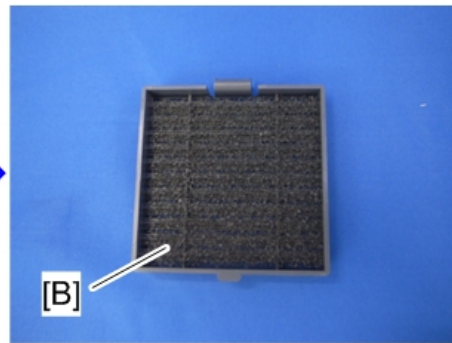
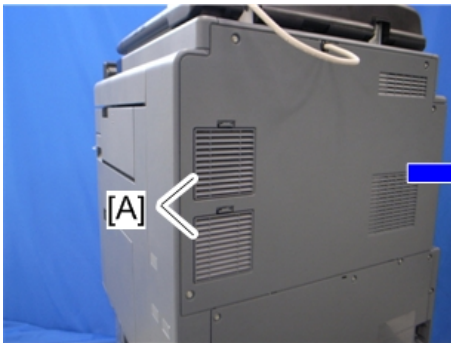

m022r511

1. Dust filter covers [A]
2. Dust filter [B]

Exhaust Filter

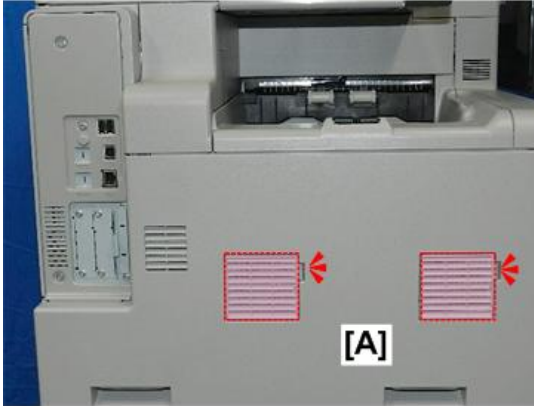

d191b0011

1. Exhaust filters [A]

Right Rear Cover

1. Rear lower cover (page 212)
2. Rear cover (page 213)
3. Open the duplex unit.

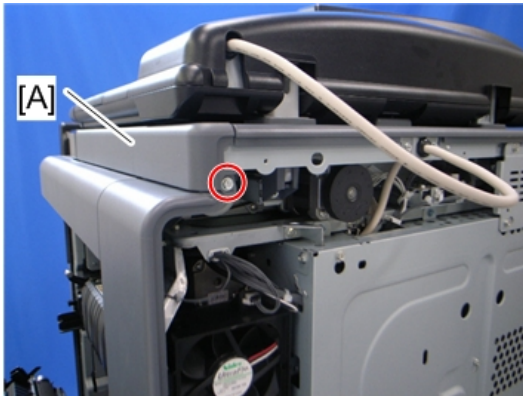

m022r513

4. Release the scanner right cover [A] (x 1)

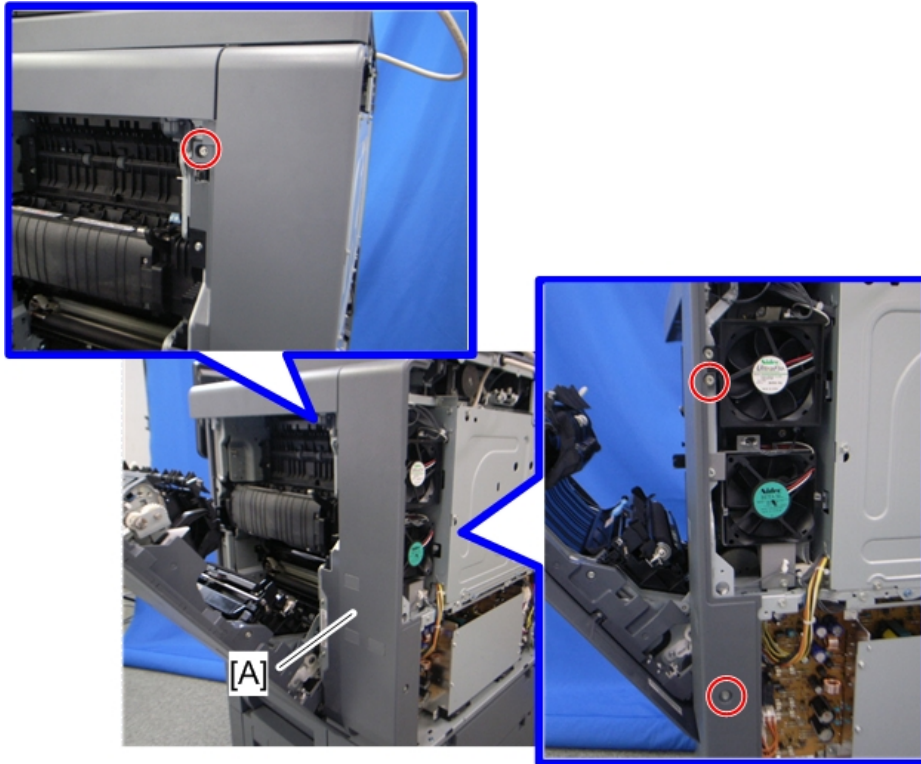

m022r514

5. Right rear cover [A] (⚙️ x 3)

Operation Panel

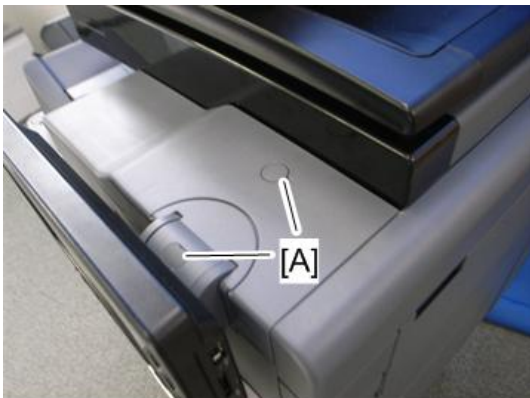

m022r515

1. Remove the two cover caps [A].

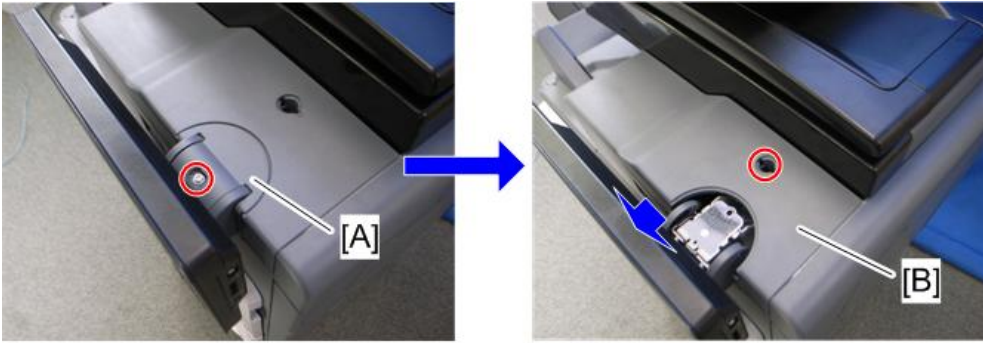

m022r516

4

2. Operation panel arm cover [A] (🔩 x 1)
3. Upper front cover [B] (🔩 x 1)

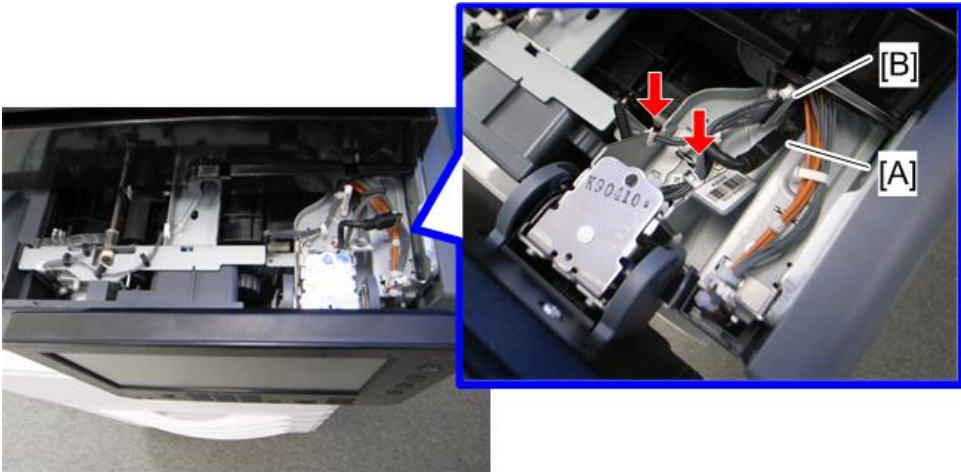

m022r517

4. Disconnect the USB cable [A] and the harness [B] (🔪 x 2).

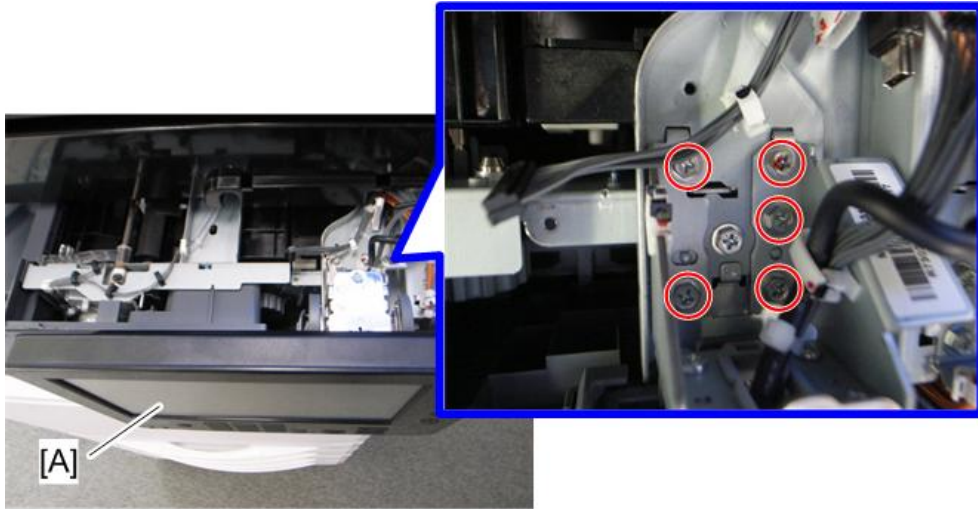

m022r518

5. Operation panel [A] (🔩 x 5)

LCD Board

1. Operation panel (🔩 page 215)

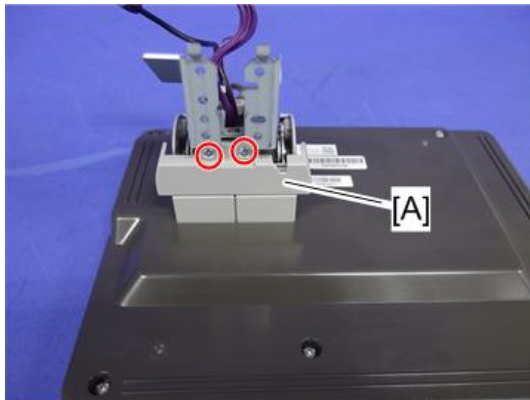

d191z5028

2. Operation panel arm holder [A] (🔩 x 2)

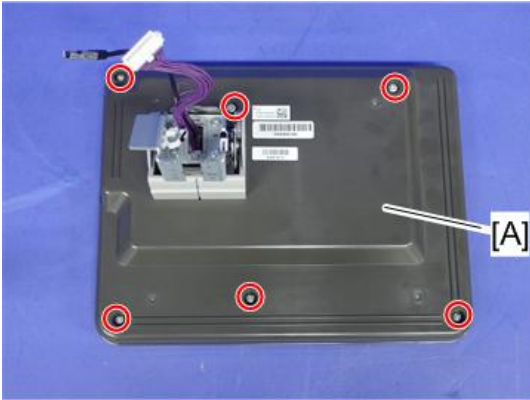

d191z5029

4

3. Operation panel rear cover [A] (⚙️ x 6)

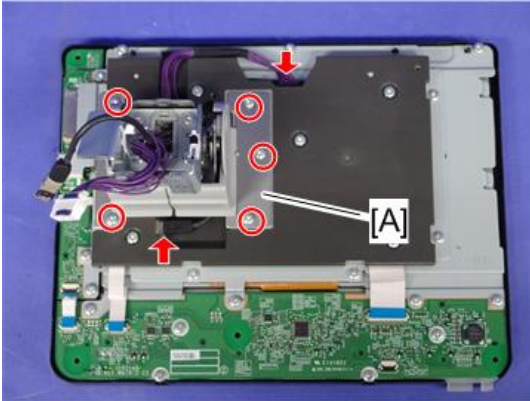

d191z5030

4. Operation panel arm unit [A] (⚙️ x 5, 📏 x 1, USB x 1)

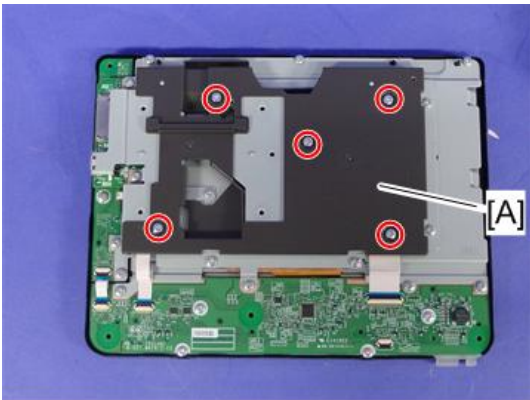

d191z5031

5. LCD board cover [A] (⚙️ x 5)

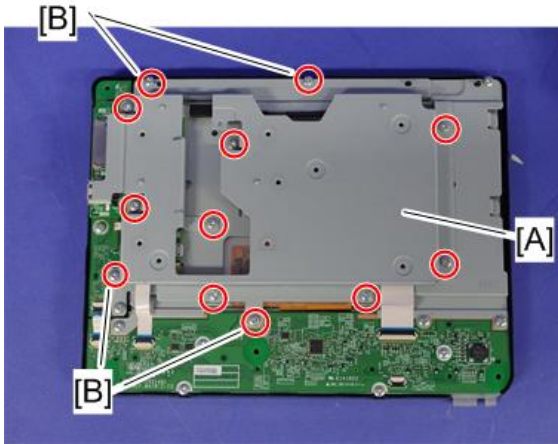

d191z5032

6. LCD board bracket [A] (🔩 x 8, M3x10 tapping screw [B] x 4)

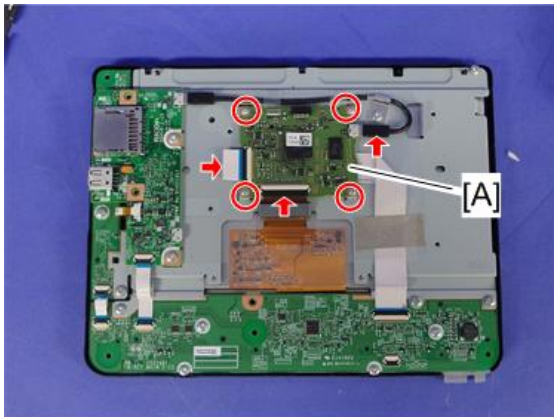

d191z5033

7. LCD board [A] (🔩 x 4, 📏 x 2, USB x1)

Operation Panel Interface Board

1. LCD board bracket (🔩 page 217 "LCD Board")



d191z5034

4

2. Operation panel interface board [A] (🔩 x 2, 📦 x 2)

LCD Unit

1. LCD board bracket (📦 page 217 "LCD Board")

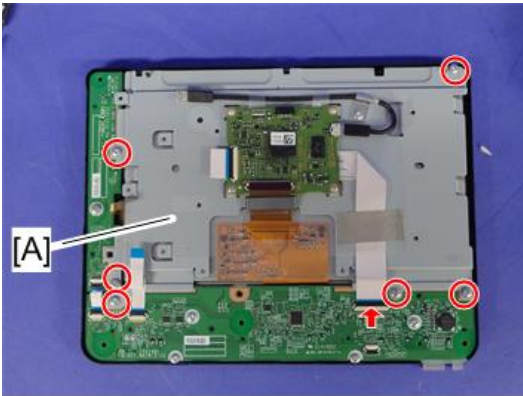

d191z5035

2. LCD bracket [A] (M3x10 🔩 x 6)



d191z5036

3. LCD unit [A]

Operation Panel Main Board

1. LCD bracket (see page 220 "LCD Unit")

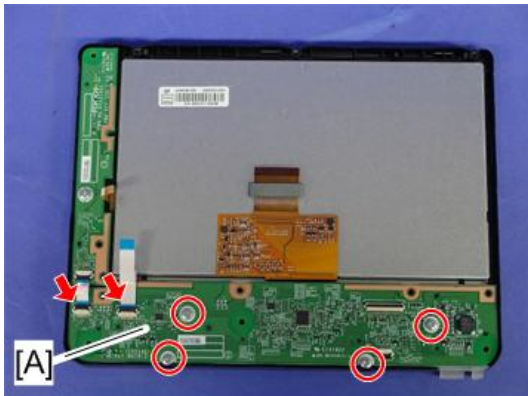

d191z5037

2. Operation panel main board [A] (M3x10  x 4,  x 2)

Operation Panel Sub Board

1. LCD bracket (see page 220 "LCD Unit")

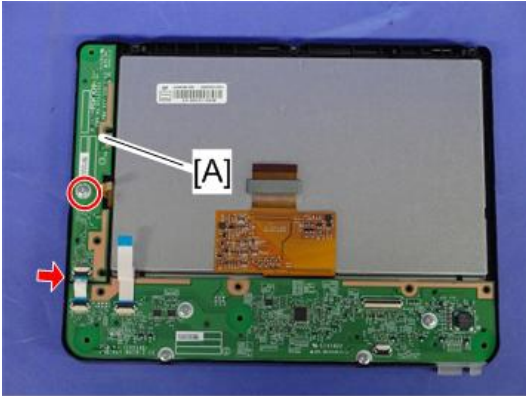



d191z5038

4

2. Operation panel sub board [A] (M3x10  x 1,  x 1)

Operation Panel Keys

1. Operation panel main board ( page 221)
2. Operation panel sub board ( page 221)

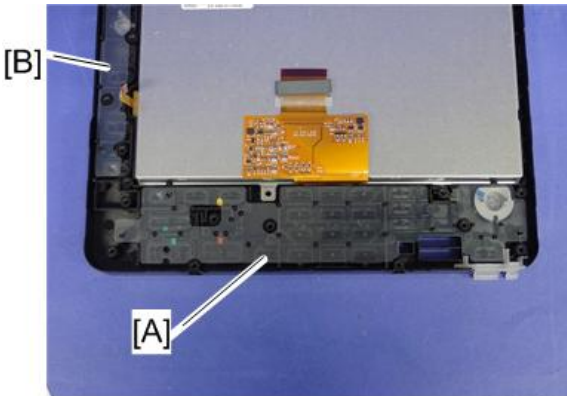

d191z5039

3. Main board sheet [A] and sub board sheet [B]

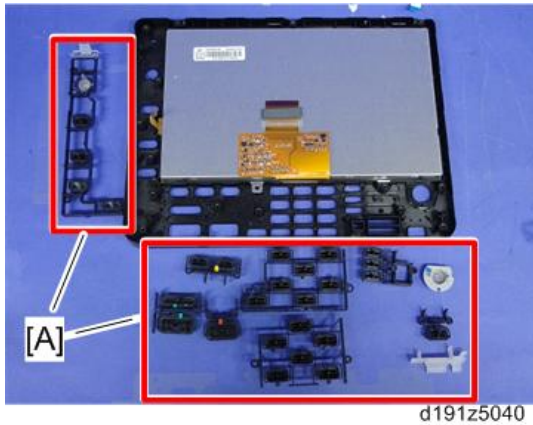

4. Operation panel keys [A]

4

Touch Panel Position Adjustment

↓ Note

- It is necessary to calibrate the touch panel at the following times:
- When you replace the operation panel.
- When you replace the controller board.
- When the touch panel detection function does not operate correctly

Do not use items [2] to [9] on the Self-Diagnostic Menu. These items are for design use only.

1. Press , press "1" "9" "9" "3" key, press "Clear/Stop" key 5 times to open the Self-Diagnostics menu.

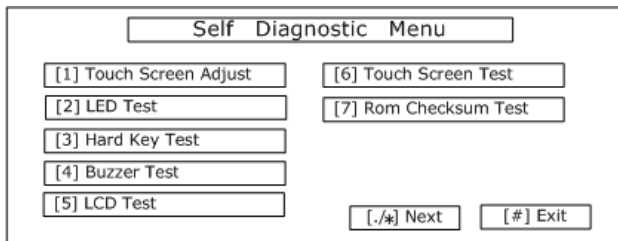

2. On the touch screen press "Touch Screen Adjust" (or press "1" key).
3. Use a pointed (not sharp) tool to press the upper left mark .

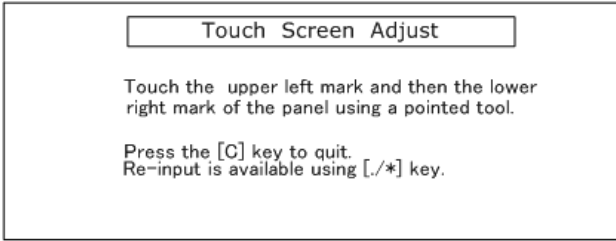

b178r549

4. Press the lower right mark when "o" shows.
5. Press [#] OK on the screen (or press Ⓢ) when you are finished.
6. Touch [#] Exit on the screen to close the Self-Diagnostic menu. Save the calibration settings.

4

Paper Exit Tray

Basic model only

1. Left cover (🔧 page 211)



d191b0024

2. Remove the left upper cover (🔧 x1).

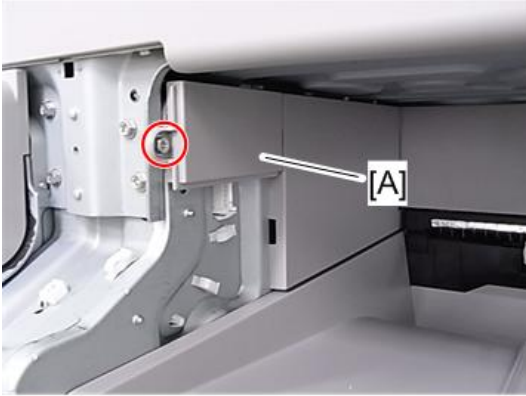

m022r868

3. Inner rear left cover [A] (🔩 x 1)

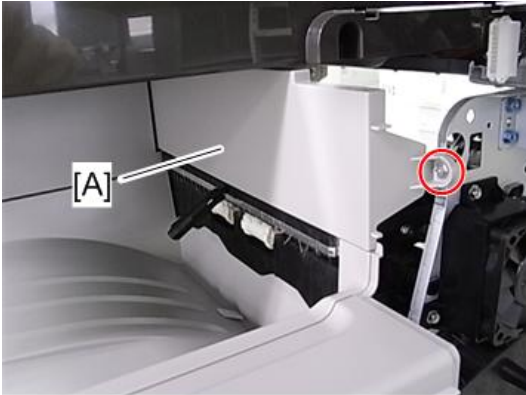

m022r869

4. Paper exit cover [A] (🔩 x 1)

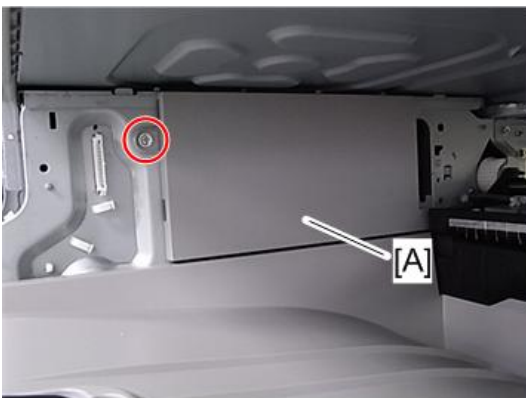

m022r870

5. Inner rear right cover [A] (🔩 x 1)

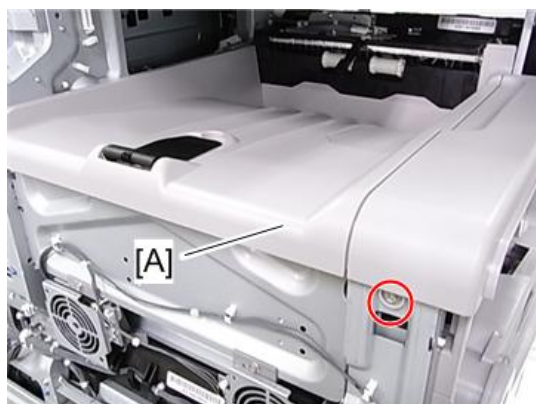

m022r871

4

6. Paper exit tray [A] (🔩 x 1)

Inner Right Cover

Basic model

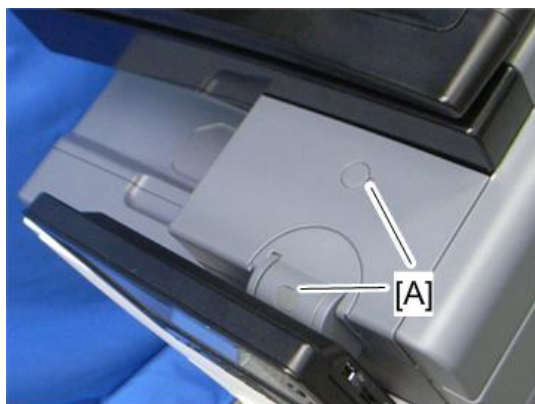

m022r515a

1. Remove the two cover caps [A].

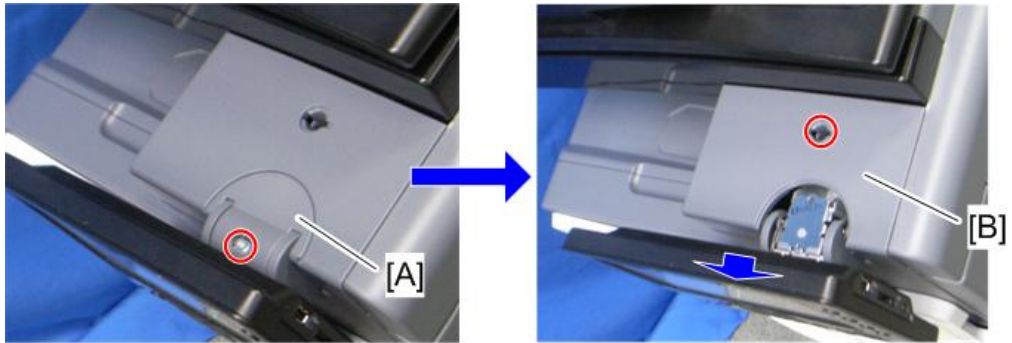

m022r516a

2. Operation panel arm cover [A] (1 x 1)
3. Upper front cover [B] (1 x 1)
4. Open the duplex unit.
5. Open the front door.

4



m022r837a

6. Remove the cover cap [A].



m022r838a

- 7. Inner right cover [A] (🔩 x 3)

Finisher model

4

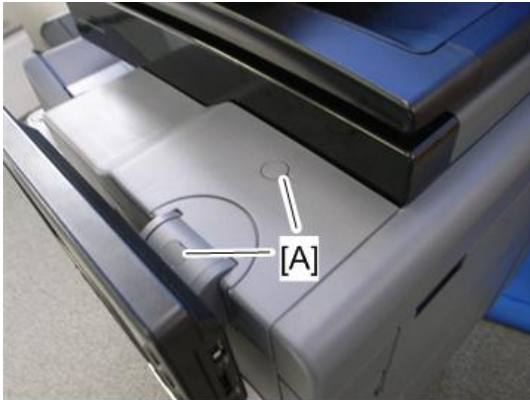

m022r515

- 1. Remove the two cover caps [A].

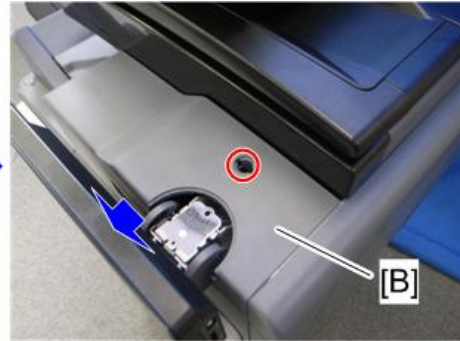
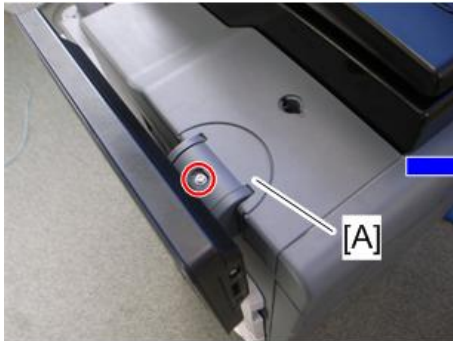

m022r516

- 2. Operation panel arm cover [A] (🔩 x 1)
- 3. Upper front cover [B] (🔩 x 1)
- 4. Open the duplex unit.
- 5. Open the front door.

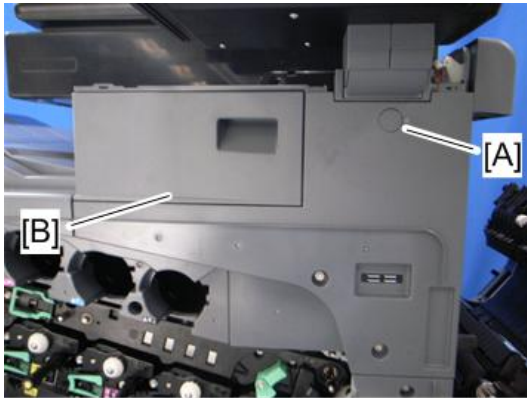

m022r837

6. Remove the cover cap [A].
7. Open the cover [B].

4



m022r838

8. Inner right cover [A] (🔩 x 4)

Inner Right Lower Cover

1. Pull out the paper tray.
2. Toner collection bottle (📄 page 210)
3. Front door (📄 page 209)
4. Open the duplex unit.

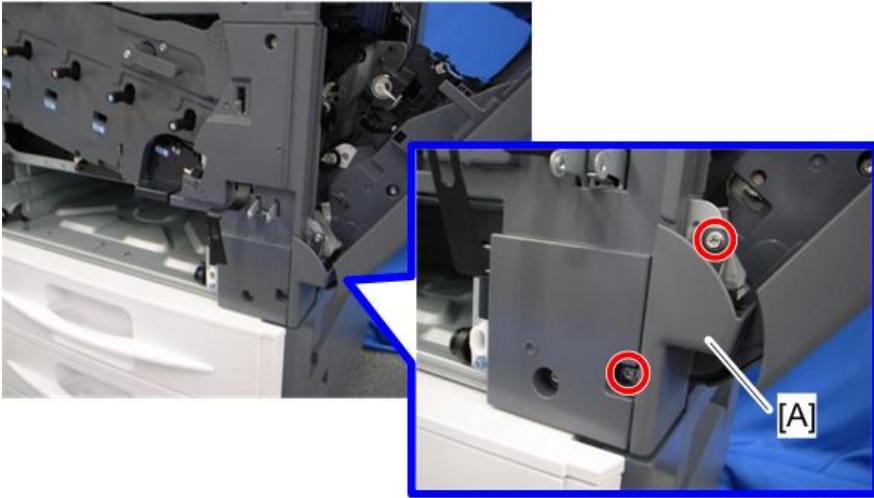

m022r581

5. Right front lower cover [A] (2 x 2)

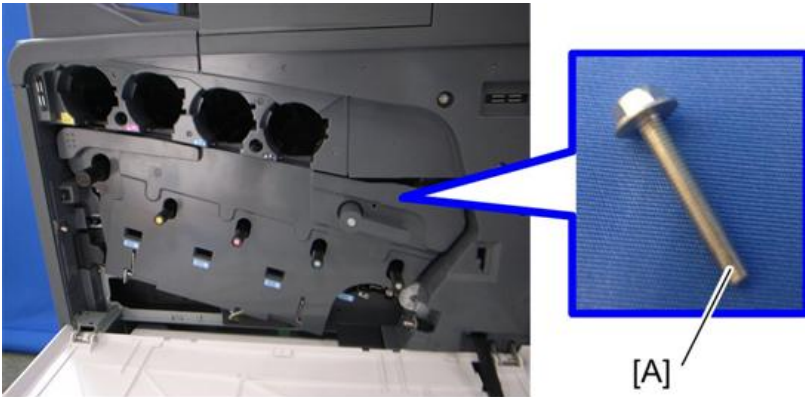

m022r834

6. Remove the long screw [A].

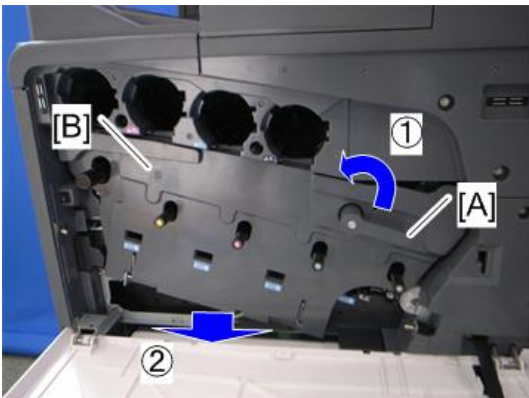

m022i506a

- Turn the lock lever [A] counterclockwise, and then open the drum securing plate [B].

Note

- Make sure that the lock lever [A] is at home position when reassembling.

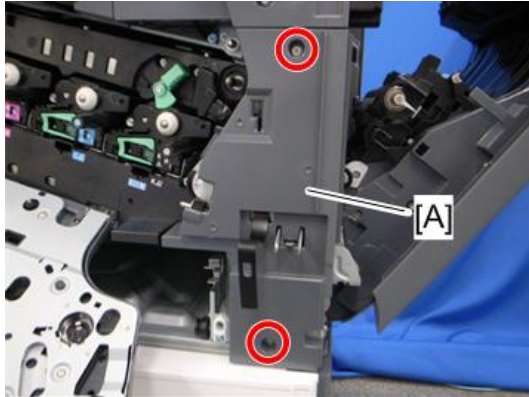

m022r582

- Inner right lower cover [A] (⚙️ x 2)

Right Upper Cover

- Open the duplex unit.

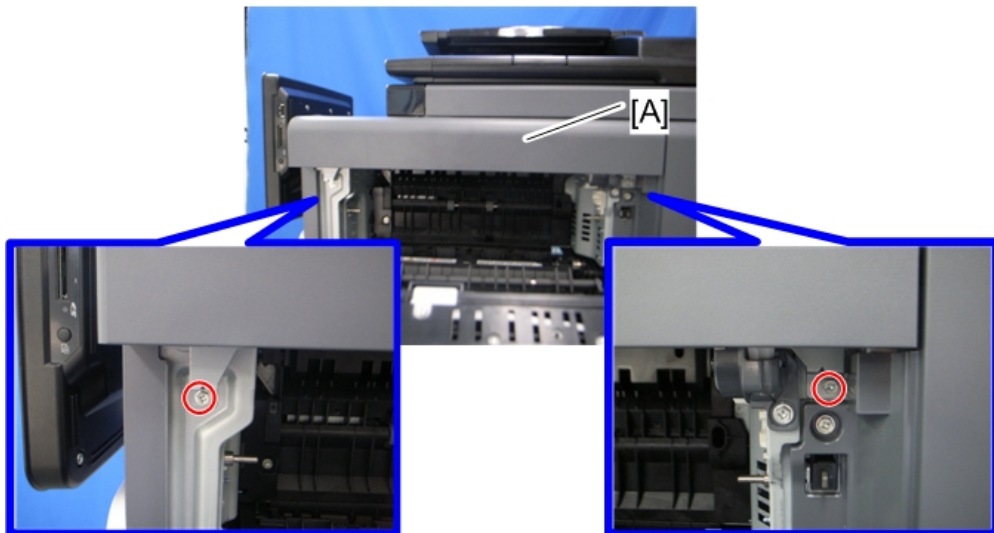

m022r512

- Right upper cover [A] (⚙️ x 2)

Scanner Unit

Exposure Glass

1. Rear cover (🔗 page 213)
2. Upper front cover (🔗 page 215)
3. Open the ARDF.

4

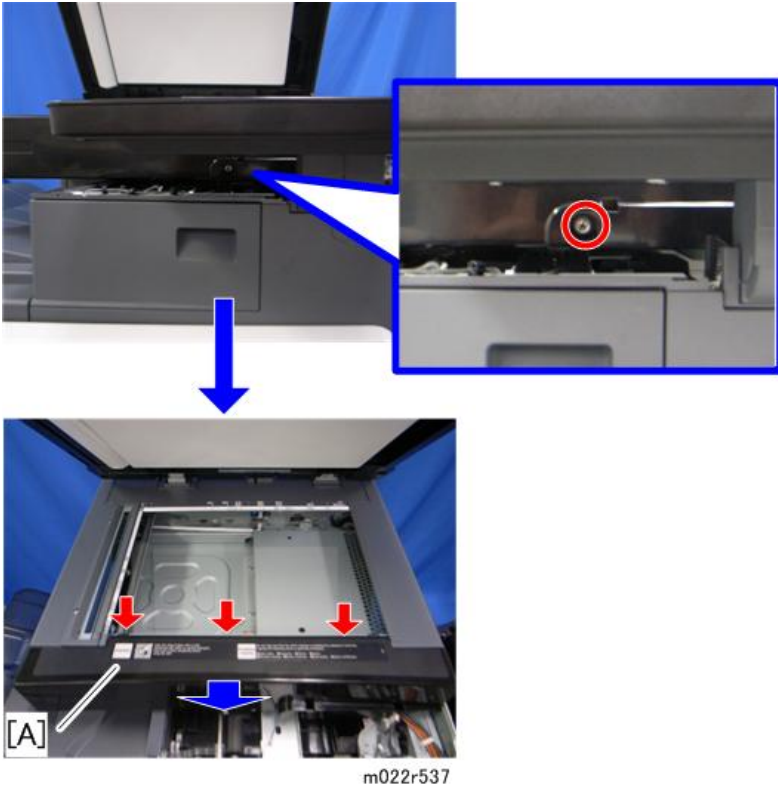

4. Scanner front cover [A] (🔗 x 1, hooks)

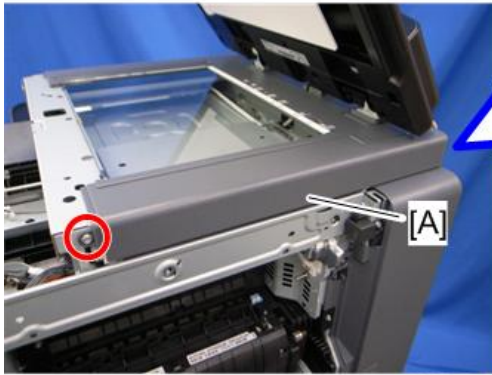

m022r538

5. Scanner right cover [A] (2 x 2)

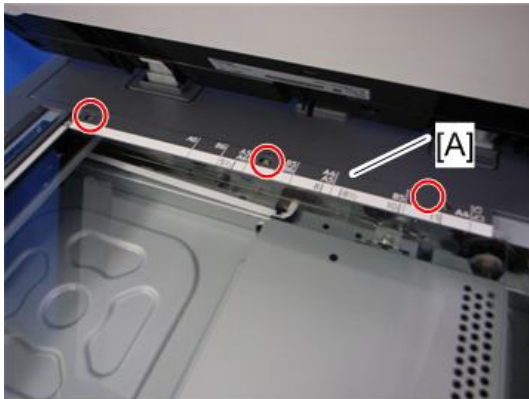

m022r539

6. Rear scale [A]

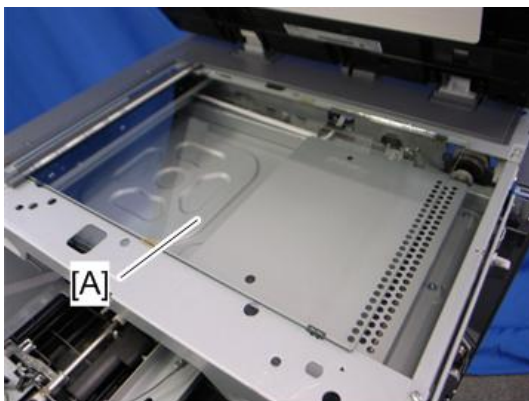

m022r540

7. Exposure glass [A]

ARDF Exposure Glass

1. ARDF (🔒 page 379)



m022r549

2. Scanner rear cover [A] (🔑 x 1).
3. Exposure glass (🔒 page 232)

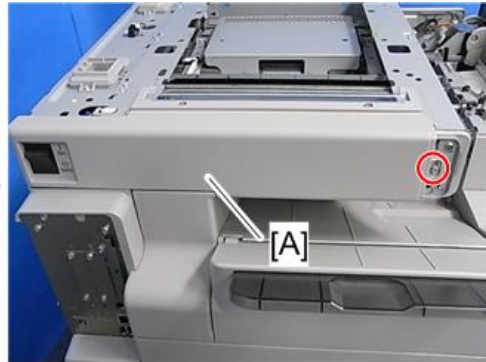

m022r922

4. Scanner left cover (🔑 x 2)

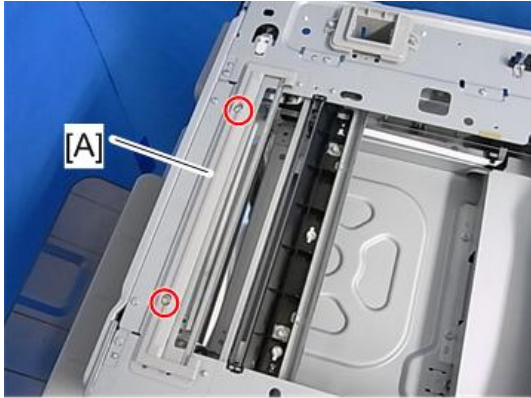

m022r921

5. ARDF exposure glass cover [A] (⚙ x 2)

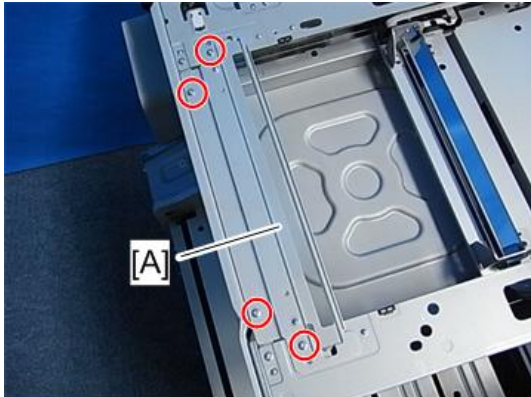

m022r887

6. ARDF exposure glass [A] with bracket (⚙ x 4).

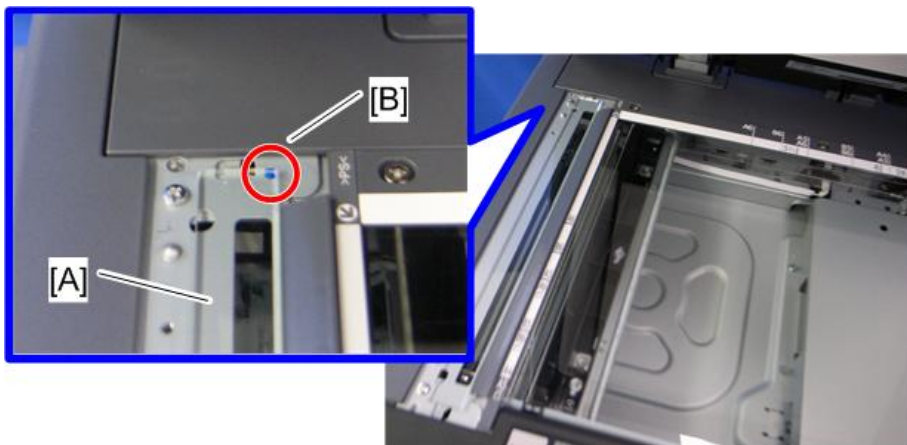

m022r542

Note

- Position the blue marker [B] at the rear-right corner when you reattach the ARDF exposure glass [A].

LED Board

Note

- Do not touch the new LED board directly by hand. Grease spots will cause poor scanning quality.
1. ARDF (page 379)
 2. Scanner rear cover (page 234 "ARDF Exposure Glass")
 3. Exposure glass (page 232)

4

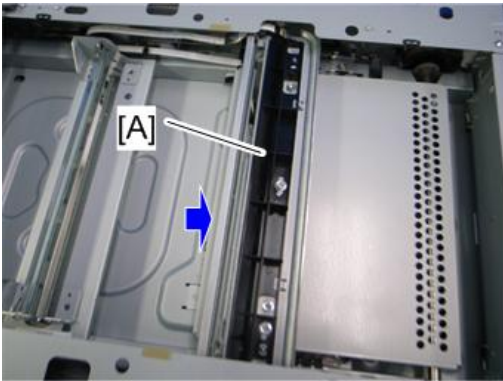

m022r559

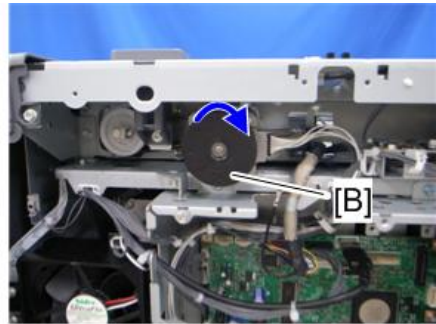

4. Move the 1st scanner carriage [A] to the right side by rotating the scanner motor [B] clockwise.

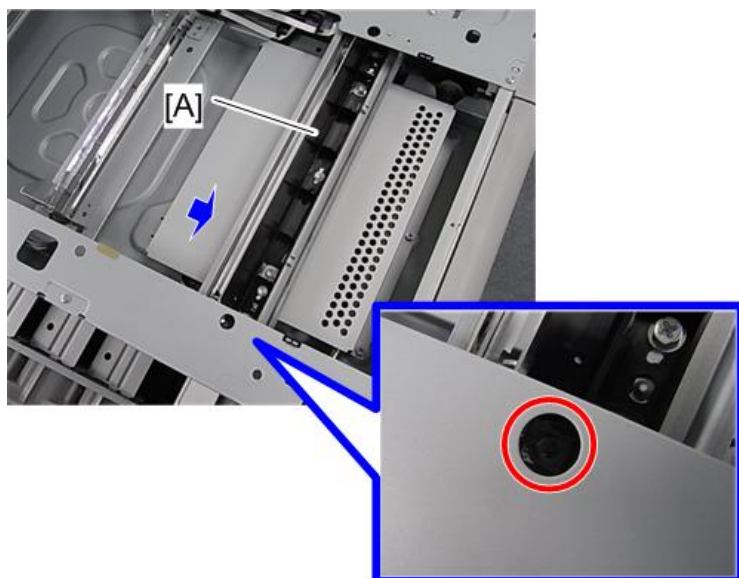

m022r561

5. Move the 1st scanner carriage [A] to the right side by rotating the scanner motor clockwise, and then remove the screw at the front side.

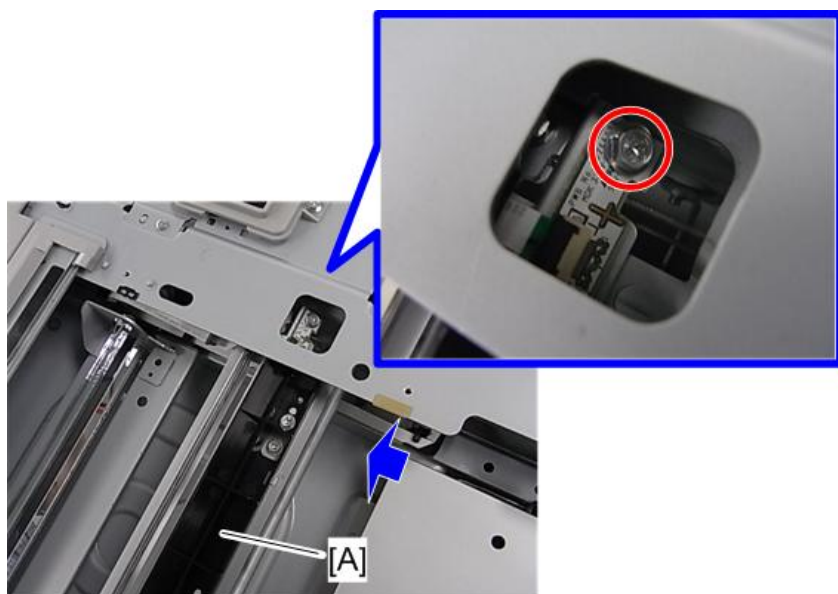

m022r562

6. Move the 1st scanner carriage [A] to the left side by rotating the scanner motor counterclockwise, and then remove the screw at the rear side.

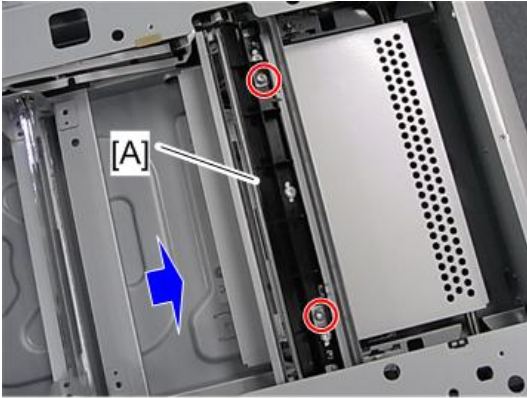

m022r563

4

7. Move the 1st scanner carriage [A] to the right side by rotating the scanner motor clockwise.

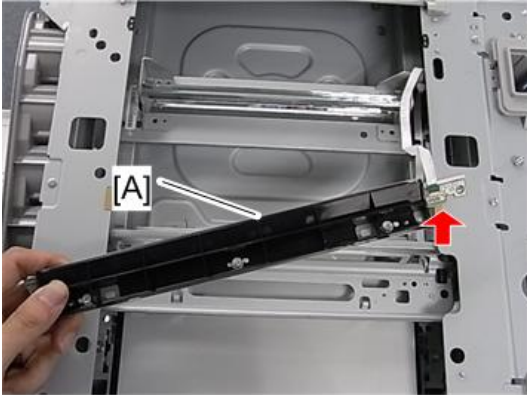

m022r833

8. LED board [A] ( x 1)

Scanner Motor

1. Rear cover ( page 213)

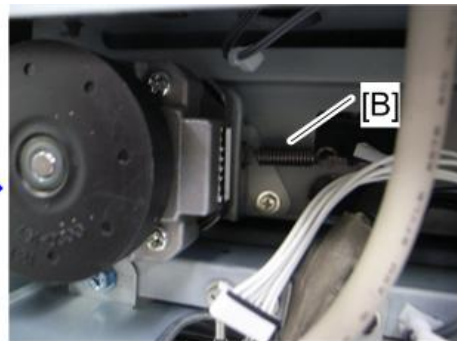
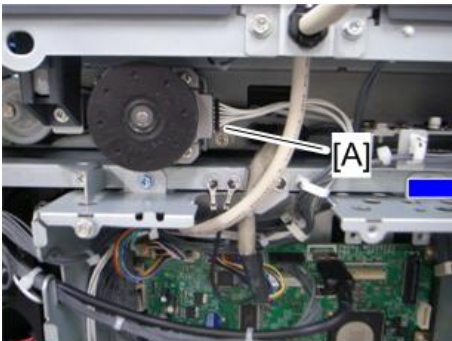

m022r543

2. Disconnect the harness [A] and remove the spring [B].

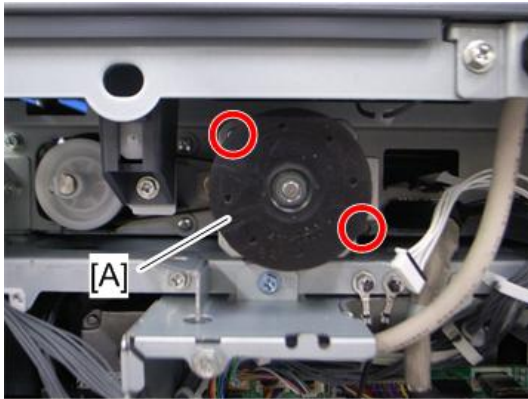

m022r544

3. Scanner motor assembly [A] (⚙ x 2, timing belt x 1)

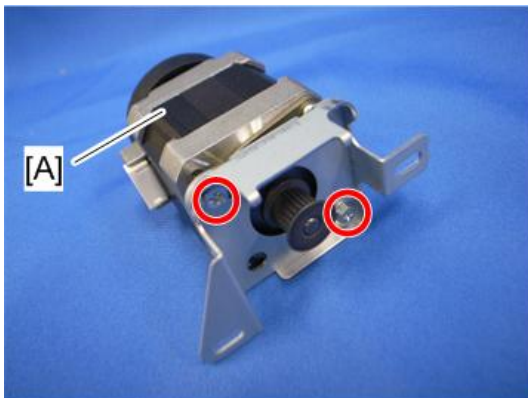

m022r545

4. Scanner motor [A] (⚙ x 2)

↓ Note

- Do the scanner image adjustment after replacing the scanner motor (see "Image Adjustment")

Sensor Board Unit (SBU)

1. Exposure glass (🖨 page 232)

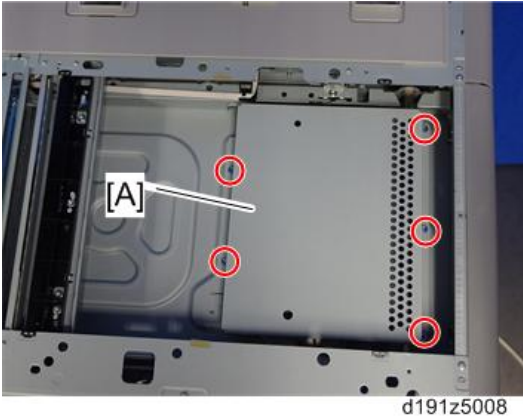

4

2. Bracket [A] (🔩 x 5)

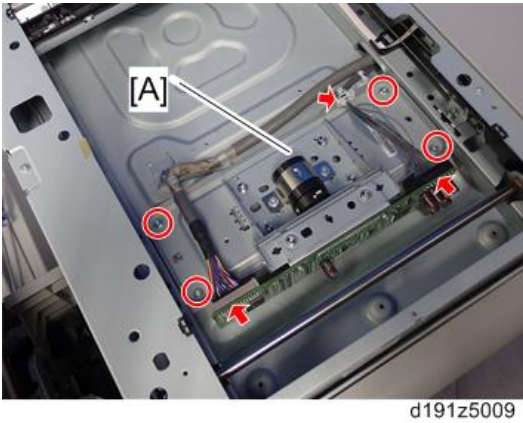

3. Sensor board unit [A] (🔩 x 4, ground screw x 1, 📡 x 2)

When reassembling

Adjust the following SP modes after you replace the sensor board unit:

- SP4-008 (Sub Scan Mag): See "Image Adjustment: Scanning" (📖 page 198).
- SP4-010 (Sub Mag Reg.): See "Image Adjustment: Scanning" (📖 page 198).
- SP4-011 (Main Scan Reg): See "Image Adjustment: Scanning" (📖 page 198).
- SP4-688 (DF: Density Adjustment): Use this to adjust the density level if the ID of outputs made in the DF and Platen mode is different.

IDB

1. Rear lower cover (📖 page 212)
2. Rear cover (📖 page 213)



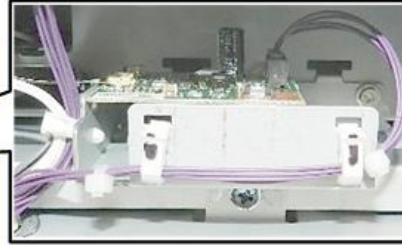

d191b0012

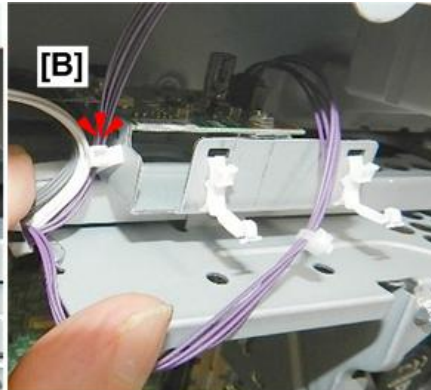
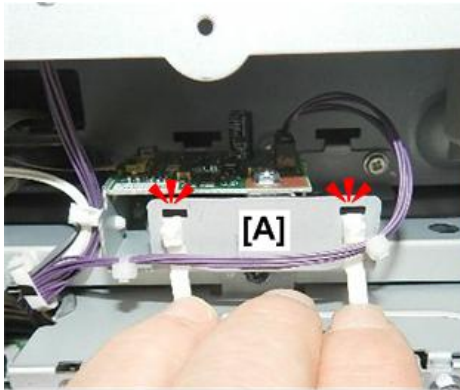

3. The IDB is located above the IPU.



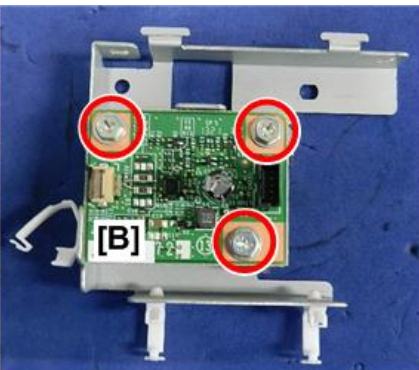
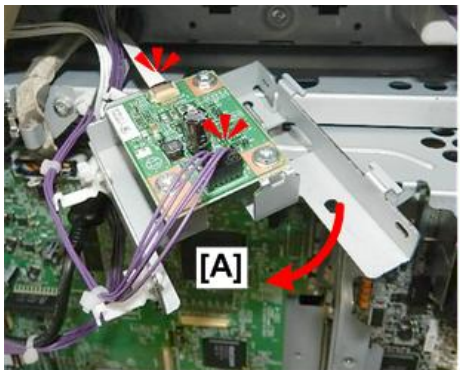

d191b0013

4. Free the harness at the front [A] ( x2).
5. Free the harnesses at the corner [B] ( x1).



d191b0014

6. Slowly, pull the bracket [A] out partially, and then disconnect the boards ( x1,  x1).
7. Separate the board [B] from the bracket ( x3).

Scanner HP Sensor

1. ARDF (page 379)
2. Scanner rear cover (page 234)

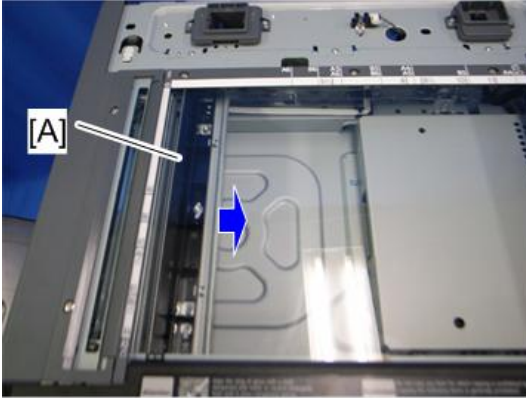

m022r551

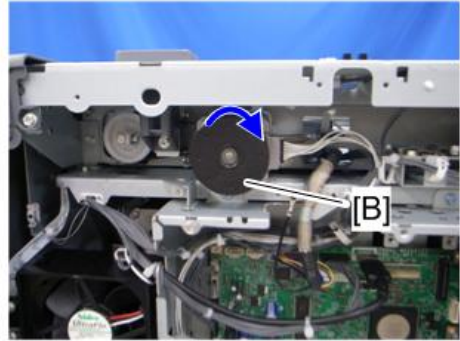

3. Move the 1st scanner carriage [A] to the right side by rotating the scanner motor [B] clockwise.

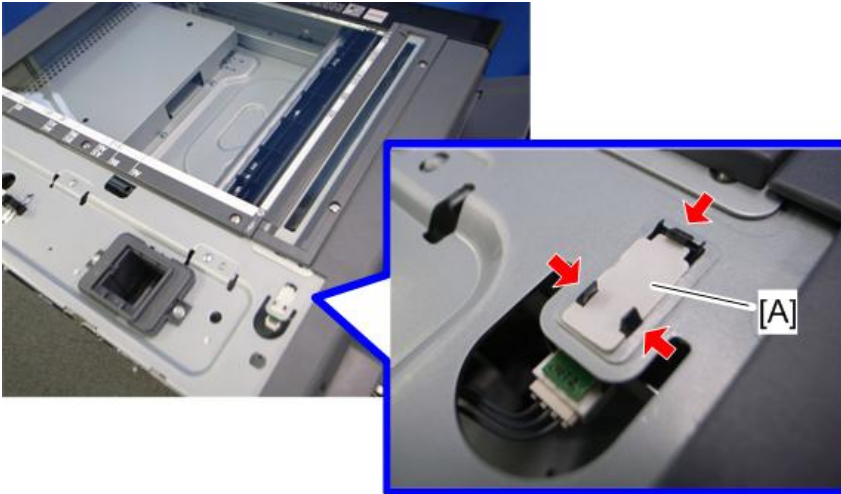

m022r552

4. Remove the mylar [A].
5. Release the three hooks.

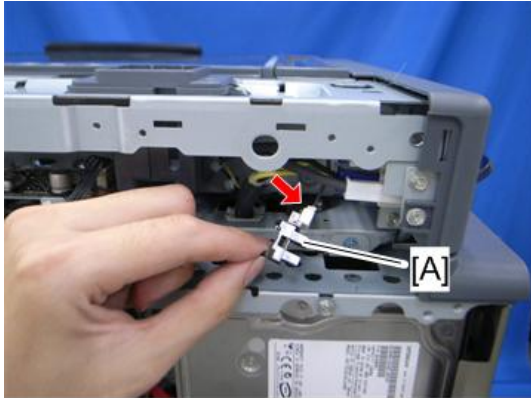

m022r553

6. Scanner HP sensor [A] (📎 x 1).

4

Cover Sensor

1. ARDF (📎 page 379)
2. Scanner rear cover (📎 page 234)

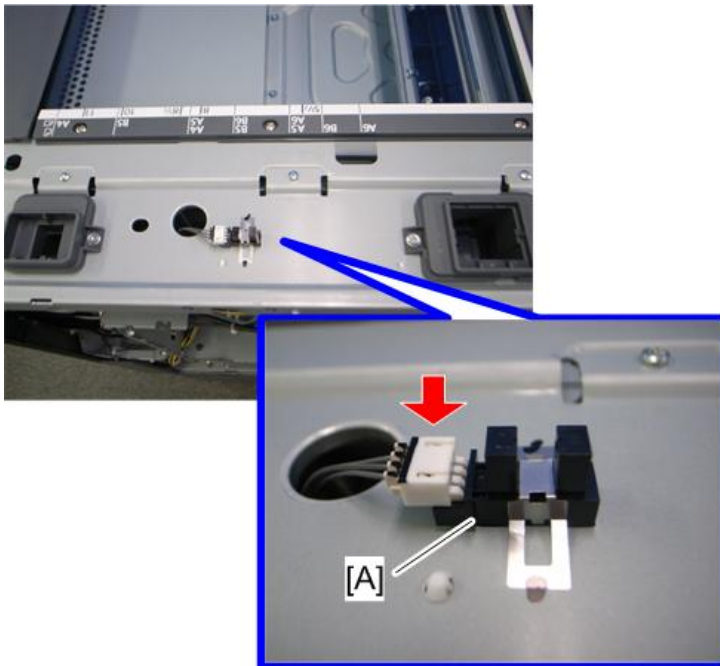

m022r550

3. Cover sensor [A] (📎 x 1, hooks)

Front Scanner Wire

1. ARDF (🔒 page 379)
2. Scanner front cover (🔒 page 234)
3. Scanner right cover (🔒 page 232)
4. Scanner left cover (🔒 page 234)

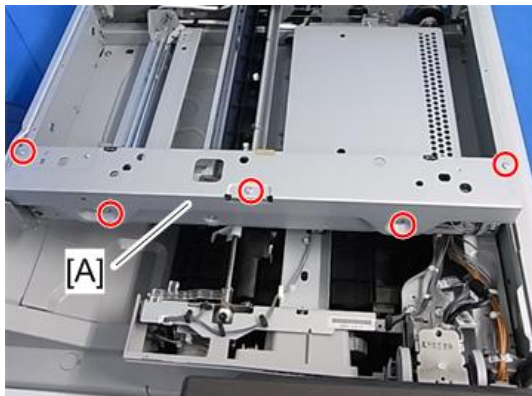

m022r917

5. Scanner front frame [A] (🔩 x 5)

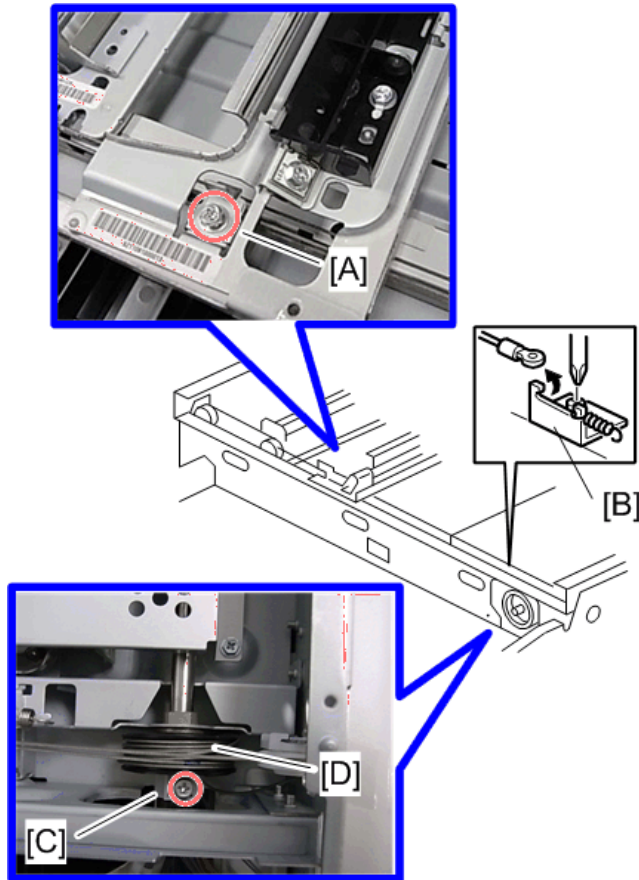

m022r911

6. Front scanner wire holder [A] (🔩 x 1)
7. Front scanner wire bracket [B] (🔩 x 1)
8. Front scanner wire, white clip [C] and scanner drive pulley [D] (🔩 x 1)

Reinstalling the Front Scanner Wire

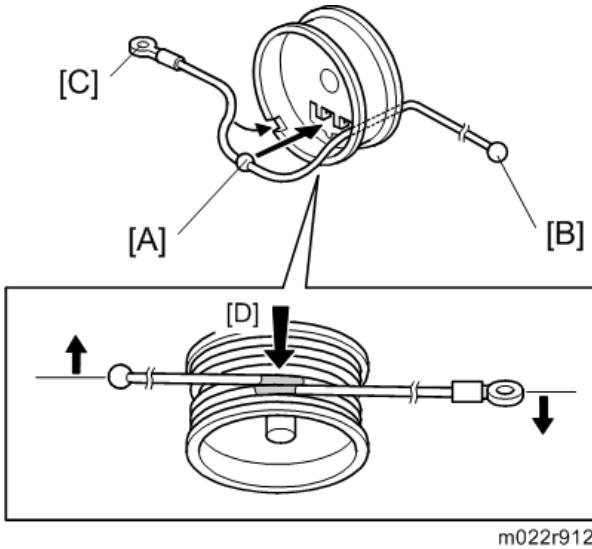

1. Position the center ball [A] in the middle of the forked holder.
2. Pass the right end (with the ball) [B] through the square hole. Pass the left end (with the ring) [C] through the notch.
3. Wind the right end counterclockwise (shown from the machine's front). Wind the left end clockwise.

Note

- The two blue marks [D] come together when you have done this. Stick the wire to the pulley with tape. This lets you easily handle the assembly at the time of installation.

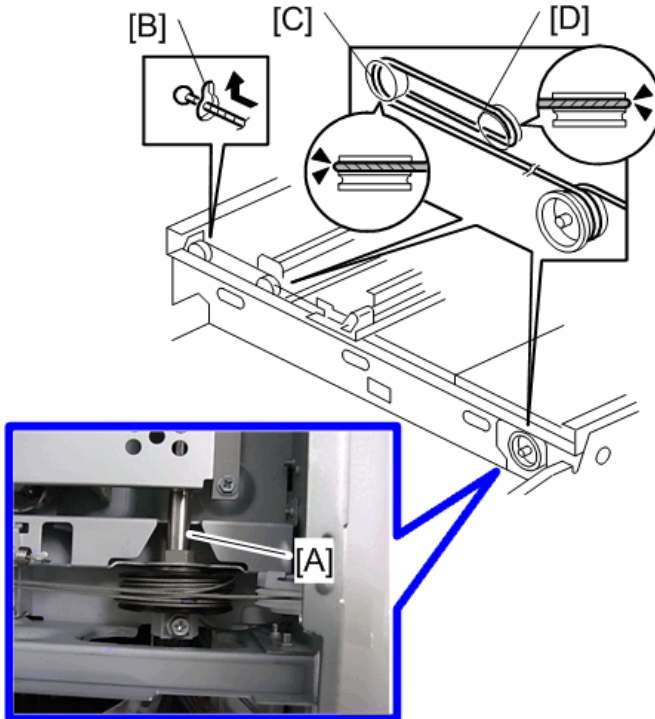

m022r913

4. Install the drive pulley on the shaft [A].

Note

- Do not attach the pulley to the shaft with the screw at this time.

5. Insert the left end into the slit [B]. The end should go via the rear track of the left pulley [C] and the rear track of the movable pulley [D].

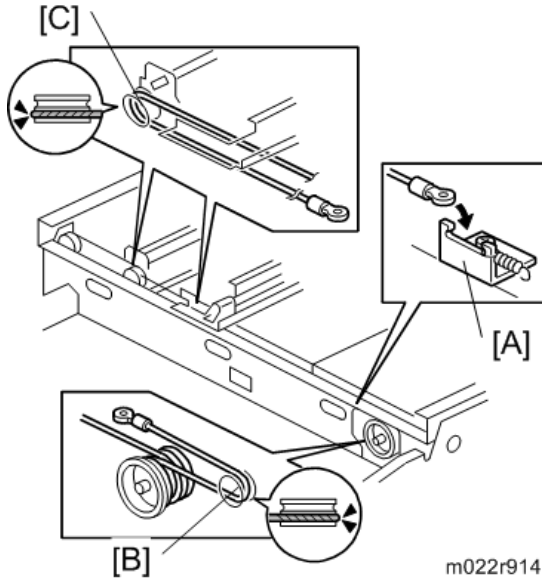

m022r914

4

6. Hook the right end onto the front scanner wire bracket [A]. The end should go via the front track of the right pulley [B] and the front track of the movable pulley [C].

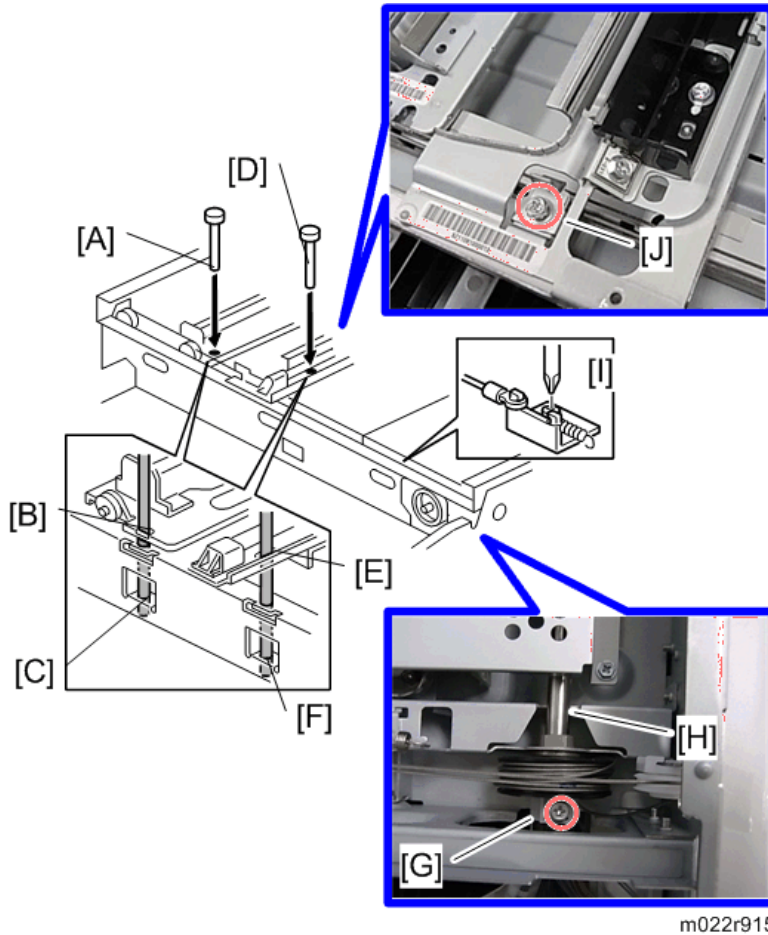

7. Remove the tape from the drive pulley.
8. Insert a scanner-positioning pin [A] through the 2 nd carriage hole [B] and the left holes [C] in the front rail. Insert another scanner positioning pin [D] through the 1 st carriage hole [E] and the right holes in the front rail [F].
9. Insert two more scanner positioning pins through the holes in the rear rail.
10. Install the white clip [G] and drive pulley to the shaft [H] (1 x 1).
11. Screw the scanner wire bracket to the front rail [I].
12. Screw the scanner wire holder [J].
13. Pull out the positioning pins.

Note

- Make sure the 1st and 2nd carriages move smoothly after you remove the positioning pins. Do steps 8 through 13 again if they do not.

Rear Scanner Wire

1. ARDF (☞ page 379)
2. Scanner rear cover (☞ page 234)
3. Scanner front cover (☞ page 232)
4. Scanner right cover (☞ page 232)
5. Scanner left cover (☞ page 234)

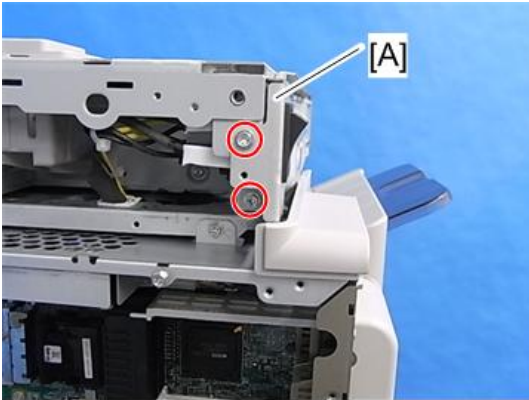

m022r918

6. Main power switch bracket [A] (☞ x 2)

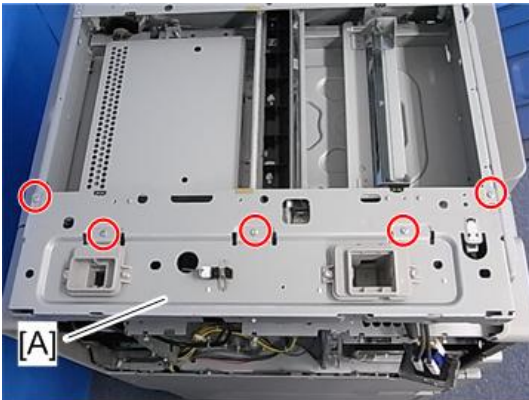

m022r919

7. Scanner rear frame [A] (☞ x 5)

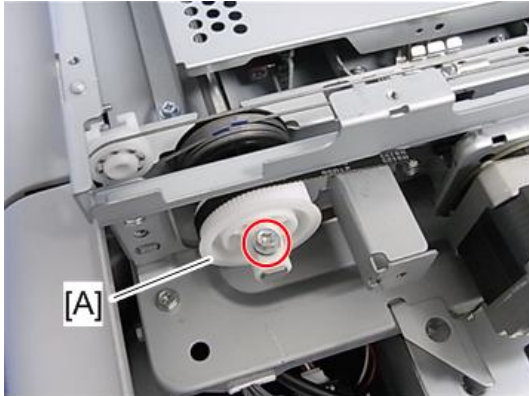

m022r920

8. White pulley [A] (1 x 1)
9. Follow steps 6 through 8 in the "Front Scanner Wire" Section. You can remove the rear scanner wire with the same manner for replacing the front scanner wire.

4

Reinstalling the Rear Scanner Wire

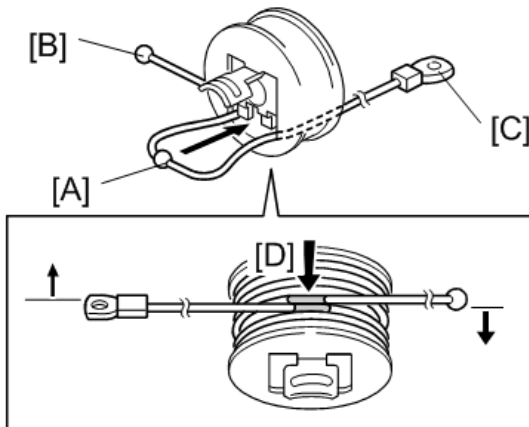

m022r916

1. Position the center ball [A] in the middle of the forked holder.
2. Pass the left end (with the ball) [B] through the drive pulley notch. Pass the right end (with the ring) [C] through the drive pulley hole.
3. Wind the left end [B] clockwise (shown from the machine's front). Wind the right end [C] counterclockwise.

↓ Note

- The two blue marks [D] come together when you do this. Attach the wire to the pulley with tape. This lets you easily handle the assembly at the time of installation.
4. Install the drive pulley on the shaft.

↓ **Note**

- Do not attach the pulley on the shaft with the screw at this time.

5. Install the wire.

↓ **Note**

- The winding of the wire on the three pulleys at the rear of the scanner should be the same as the winding on the three pulleys at the front. This must show as a mirror image.

Example: At the front of the machine, the side of the drive pulley with the three windings must face the front of the machine. At the rear of the machine, it must face the rear.

6. Do steps 7 through 13 again in the "Front Scanner Wire" Section.

Laser Optics

⚠️ WARNING

- Turn off the main power switch and unplug the machine before beginning any of the procedures in this section. Laser beams can cause serious eye injury.

Caution Decal Location

Caution decal is attached as shown below.



m022r507a

⚠️ WARNING

- Be sure to turn off the main power switch and disconnect the power plug from the power outlet before beginning any disassembly or adjustment of the laser unit. This machine uses a class IIIb laser beam with a wavelength of 653 - 665 nm and an output of 15 mW. The laser can cause serious eye injury.

Laser Unit

⚠️ CAUTION

- Before installing a new laser unit, remove the polygon motor holder bracket and the tag from the new unit.

↓ Note

- A new laser optics housing unit has a bracket to protect the LD units. When you install the new unit, do not remove the bracket until near the end of the installation procedure (the correct time is stated in the manual).
- This bracket protects a capacitor on the unit. If the bracket is removed too early, you could break the capacitor on the corner of the main frame when you install the new unit.

Preparing the new laser unit

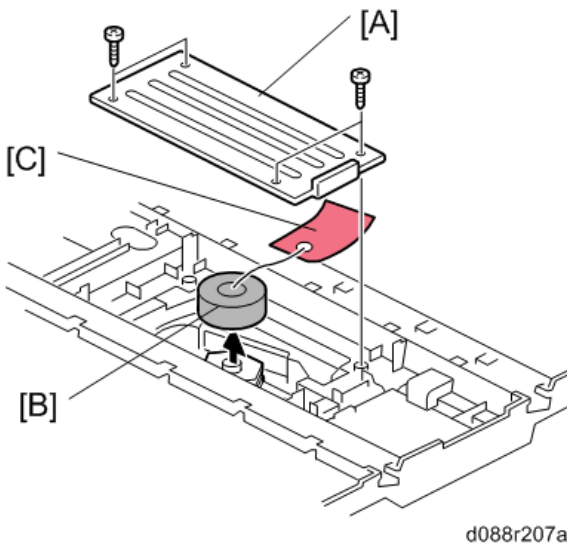

1. Polygon motor cover [A] of the laser unit (4 x 4)
2. Sponge padding [B]
3. Tag [C]
4. Reinstall the polygon motor cover [A].

Before removing the old laser unit

Do the following settings before removing the laser unit. These are adjustments for skew adjustment motors in the laser unit, main scan start position, and laser diode power.

1. Plug in and turn on the main power switch of the machine.
2. Enter the SP mode.
3. Execute SP2-220-001 to clear the mirror positioning motor setting for Cyan.
4. Execute SP2-220-002 to clear the mirror positioning motor setting for Magenta.
5. Execute SP2-220-003 to clear the mirror positioning motor setting for Yellow.

6. Execute SP2-180-004 for clearing main scan start position adjustment setting.
7. Execute SP2-153-001 for clearing LD power.
8. Exit the SP mode.
9. Turn off the main power switch and disconnect the power cord of the copier.

Recovery procedure for no replacement preparation of laser unit

If you did not do the procedure in "Before removing the old laser unit" before removing the laser unit, you must do the following.

1. Turn off the main power switch and disconnect the power cord of the copier.
2. Left cover (page 211)

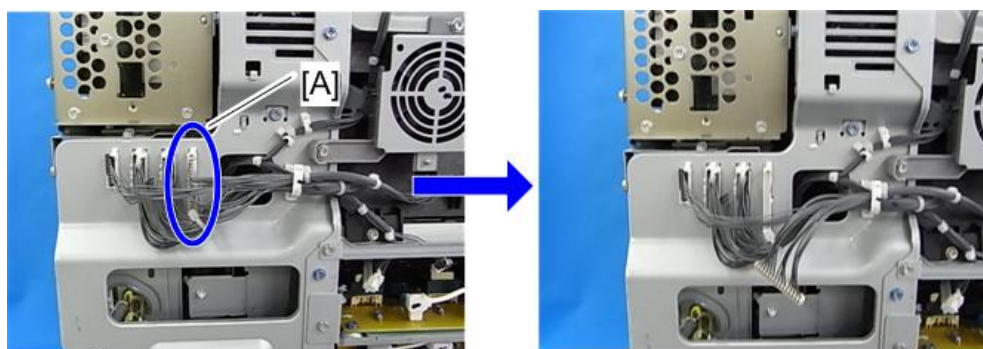

m022r890

3. Disconnect the harness [A] of the skew correction motor.
4. Do steps 1 to 9 of "Before removing the old laser unit".
5. Connect the harness [A] and reassemble the machine.
6. Plug in and turn on the main power switch.

Removing the laser unit

1. Left cover (page 211)

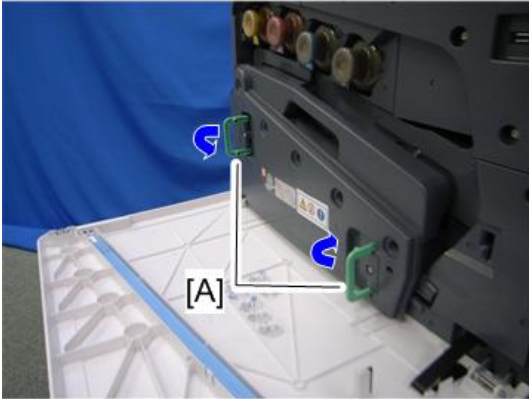

m022r503b

4

2. Ventilation fan base: rear [A] and ventilation fan base: front [B] (🔩 x 2, 📏 x 1 each)

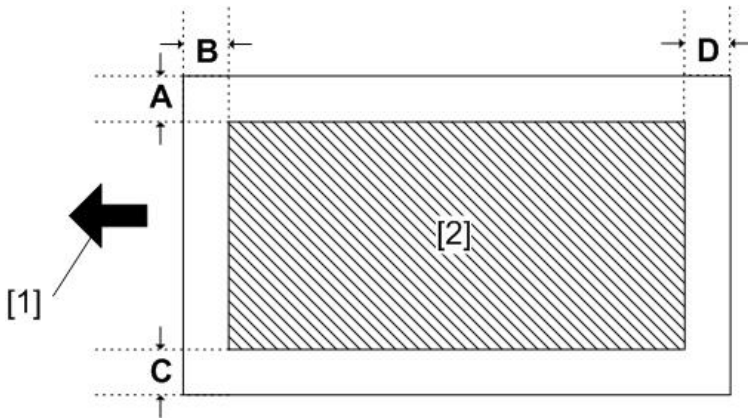

3. Left side stay [A] (🔩 x 2)

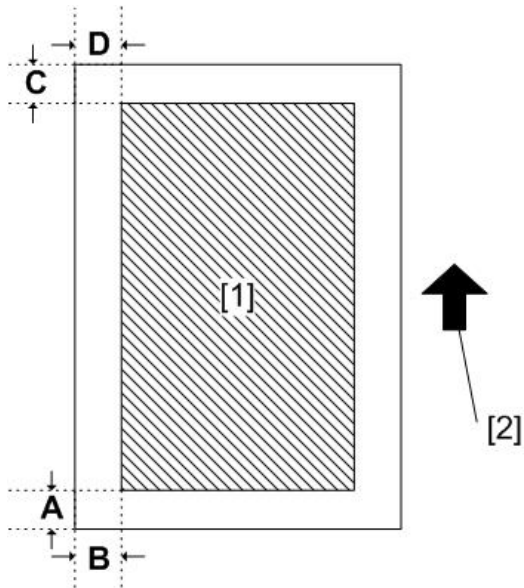

4. Disconnect the five harnesses and remove the two screws.

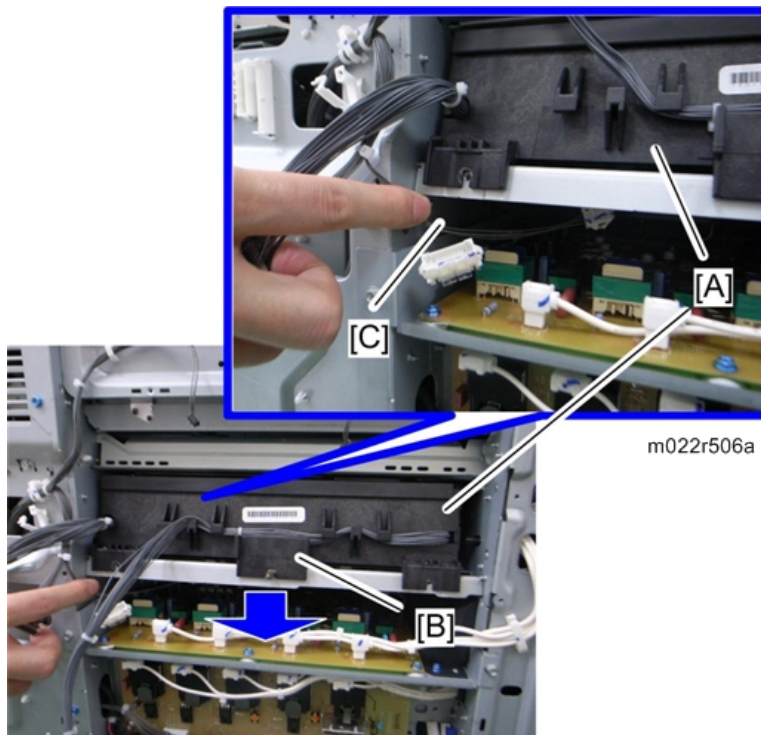

5. Pull out the laser unit [A] while holding the plate [B].

Note

- Hold the harness [C] of the laser unit to one side when pulling out the laser unit.

After installing a new laser unit

Do the following adjustment after installing the new laser unit.

1. Plug in and turn on the main power switch.
2. Check that the settings of SP2-119-001, -002 and -003 are "0". If these settings are not "0", execute "Recovery procedure for no replacement preparation of laser unit" described above.

★ Important

- If this step is not correctly done, an image problem may occur on printouts.

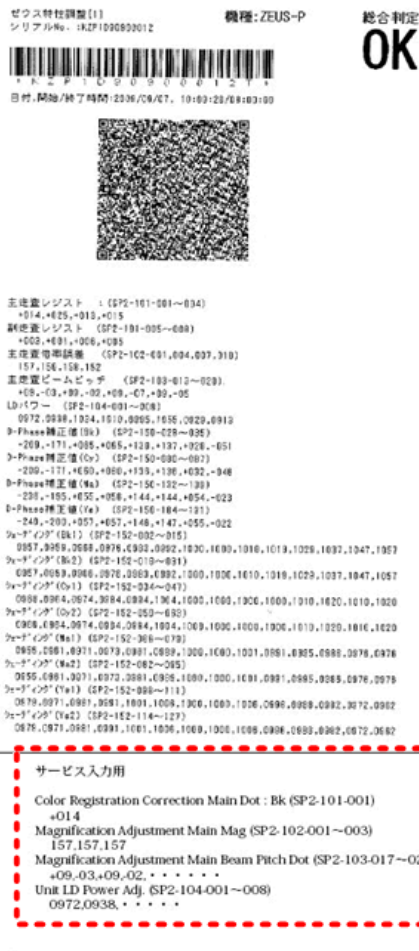

m022r883

3. Input the SP settings on the sheet provided with a new laser unit.
 - SP2-101-001: Color Registration Adjustment for Black
 - SP2-102-013, 015, 017, 019: Magnification Adjustment Main Beam Pitch Dot for each color

- SP2-102-014, 016, 018, 020: Magnification Adjustment Main Beam Pitch Subdot for each color
- SP2-102-001: Main Magnification for Black and Standard line speed
- SP2-102-002: Main Magnification for Black and Medium line speed
- SP2-102-003: Main Magnification for Black and Low line speed
- SP2-104-001 to -008: :LD Initial Power Adjustment for each color

↓ Note

- The printed values [A] are different for each laser unit.
 - If the SP settings shown above are not input correctly, it may cause color registration errors.
4. Print the test pattern (14: 1-dot trimming pattern in the SP2-109-003).
 5. Check that the left and right trim margin is within 4 ± 1 mm. If not, change the standard value for the main scan magnification adjustment.
 6. Select "0" with SP2-109-003 after printing the "1-dot trimming pattern.
 7. Do the line position adjustment.
 - First do SP2-111-003.
 - Then do SP2-111-001.
 - To check if SP 2-111-001 was successful, watch the screen during the process. A message is displayed at the end. Also, you can check the result with SP 2-194-010 to -012.
 8. Exit the SP mode.

Ventilation Fan

1. Left cover (page 211)

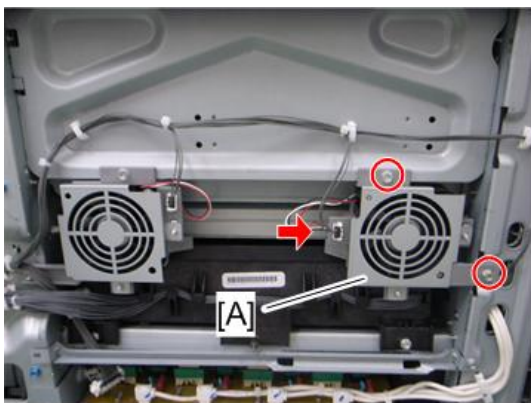

m022r845

2. Ventilation fan base [A] (🔧 x 2, 📦 x 1)

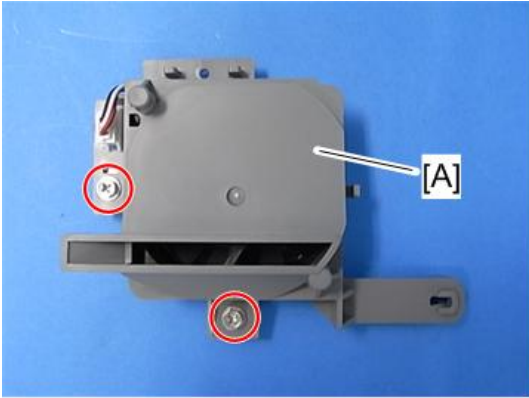

m022r844

4

3. Ventilation fan cover [A] (🔩 x 2)

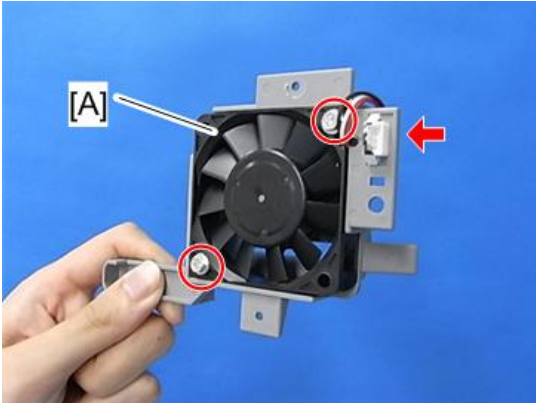

m022r846

4. Ventilation fan [A] (🔩 x 2)

When installing the ventilation fan

Make sure that the ventilation fan is installed with its decal facing the right side.

Image Creation

PCDU (Photo Conductor and Development Unit)

Note

- Do not touch the OPC drum. Do not let metal objects touch the development sleeve.
- Open the front door.
 - Toner collection bottle (see page 210)

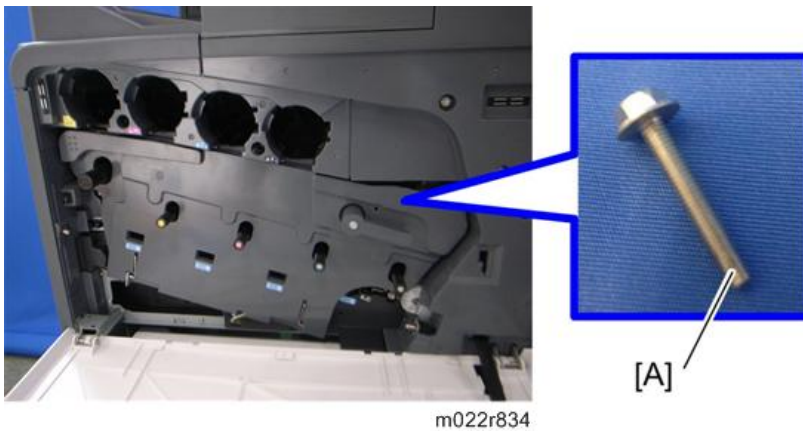

- Remove the long screw [A].

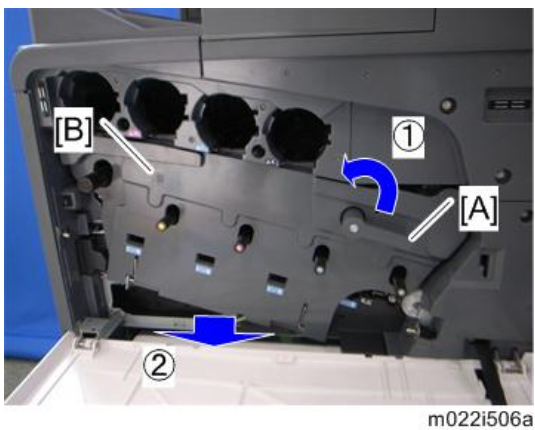

- Turn the lock lever [A] counterclockwise, and then open the drum securing plate [B].

Note

- Make sure that the lock lever [A] is at home position when reassembling.

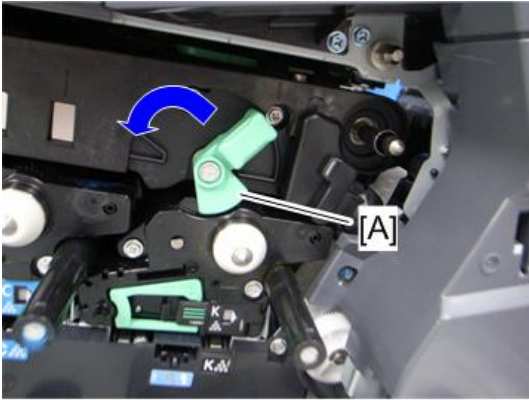

m022r565

4

5. Turn the ITB lock lever [A] counterclockwise (this step is only needed if you remove the PCDU: K).

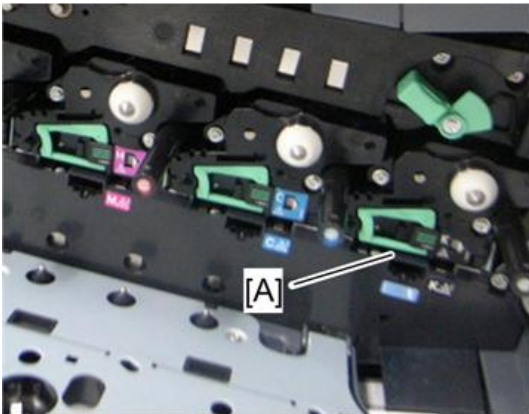

m022r839

6. PCDU [A]

When installing a new PCDU

Remove the cover on the toner inlet and pull out the tape from the new development unit before installing a new PCDU in the machine.

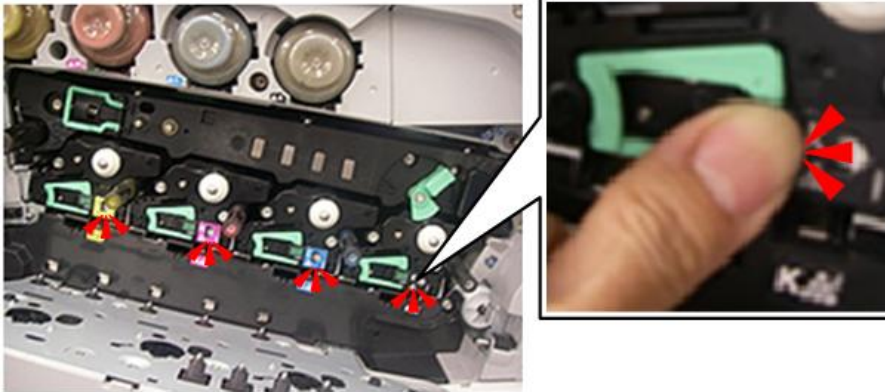

d190b0501

1. After inserting a PCDU, always push the PCDU lever in until you hear it click and lock.

4

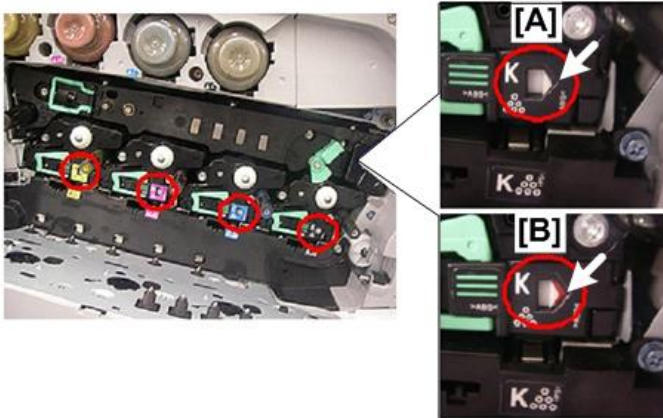

d190b0502

2. Check the five-sided window of each PCDU.

- If the area inside the window is all white [A], the unit is installed correctly.
- If you see any red color [B] inside the window, the unit is installed incorrectly.

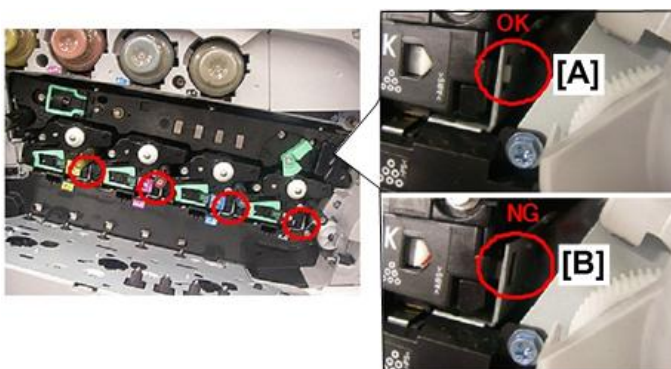

d190b0503

3. On each unit, confirm the slot and bracket alignment.

- If you see the white lock tab inside its slot [A] the unit is installed correctly.
- If you do not see the white tab inside the slot [B], the unit is installed incorrectly.



d190b0504

4. Turn the ITB lock lever clockwise to lock it.

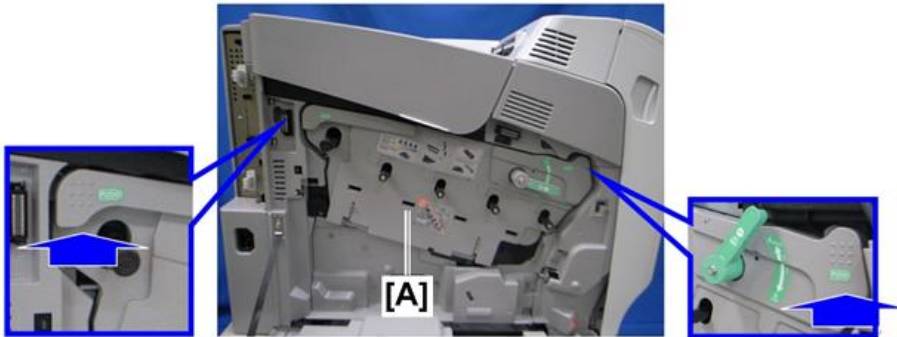

d190b0505

5. Use both hands to close the drum securing plate [A].

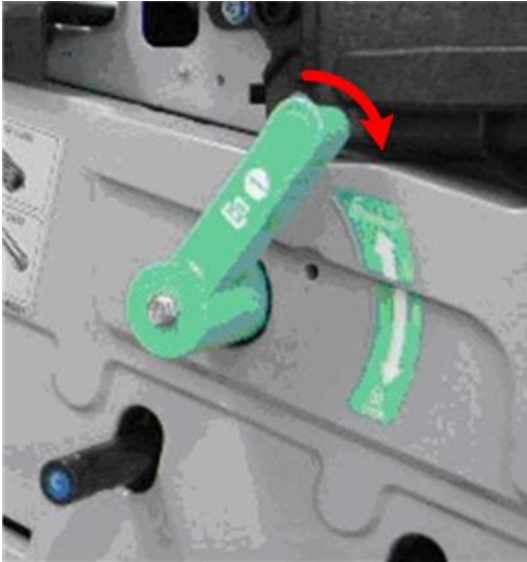

d190b0506

6. Turn the lock lever clockwise to lock it.
7. Close the front cover.

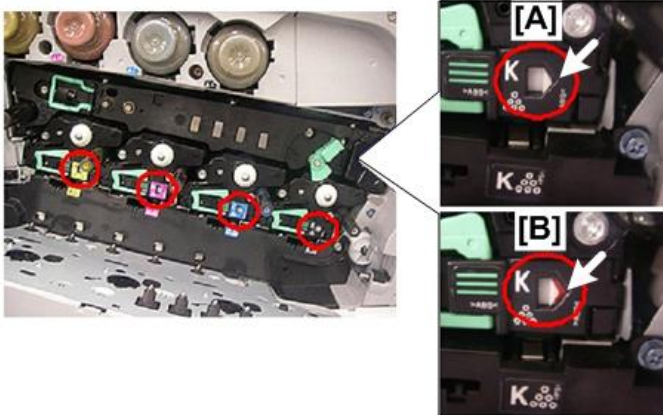

d190b0108

8. Check the five-sided window of each PCDU.
 - If the area inside the window is all white [A], the unit is installed **correctly**.
 - If you see any red color [B] inside the window, the unit is installed **incorrectly**.

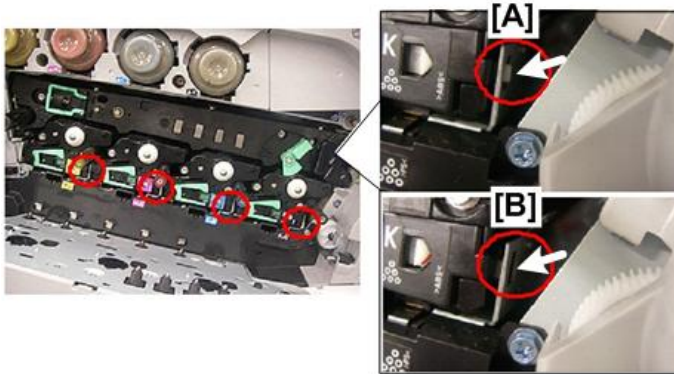

d190b0109

4

9. On each unit, confirm the slot and bracket alignment.

- If you see the white lock tab inside its slot [A] the unit is installed **correctly**.
- If you do not see the white tab inside the slot [B], the unit is installed **incorrectly**.

PCU and Development Unit

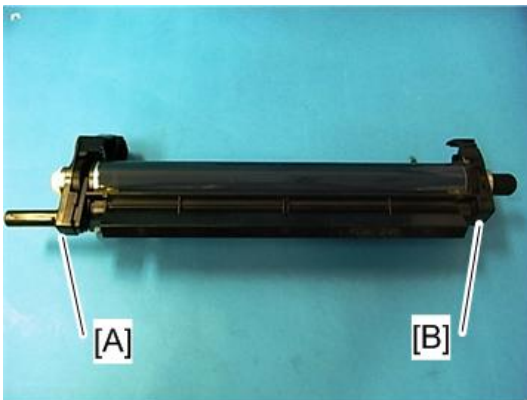

m022r881

The new PCU has front cover [A] and rear cover [B]. If you want to attach the old development unit to a new PCU, you must remove the rear cover from the new PCU first.

1. If you install a new PCU only, set SP 3902-xxx to "1".
 - Black: 3902-009
 - Cyan: 3902-010
 - Magenta: 3902-011
 - Yellow: 3902-012

Note

- If you do this, then the machine will reset the PM counter for the PCU automatically, after you turn the power on again.
2. If you install a new development unit only, set SP 3902-xxx to "1".
 - Black: 3902-001
 - Cyan: 3902-002
 - Magenta: 3902-003
 - Yellow: 3902-004

Note

- If you do this, then the machine will reset the PM counter for the development unit automatically, after you turn the power on again.
3. Turn the machine power off.
 4. PCDU (page 261)

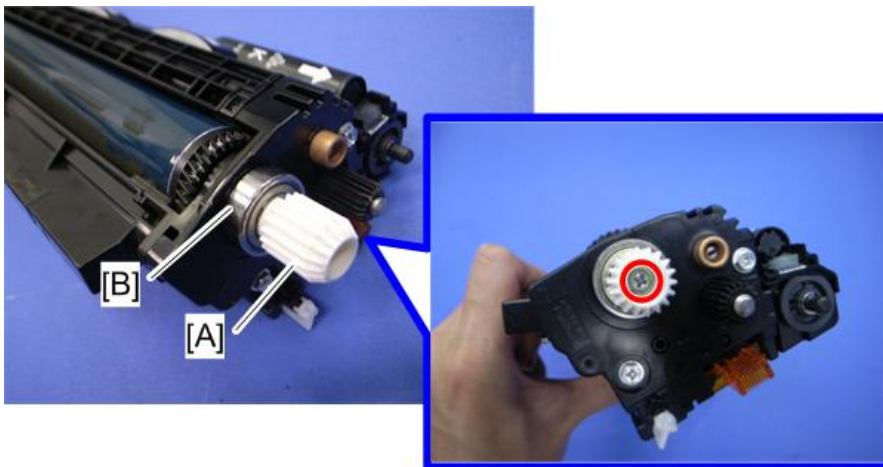

m022r554

5. Remove the gear [A] and the bearing [B].

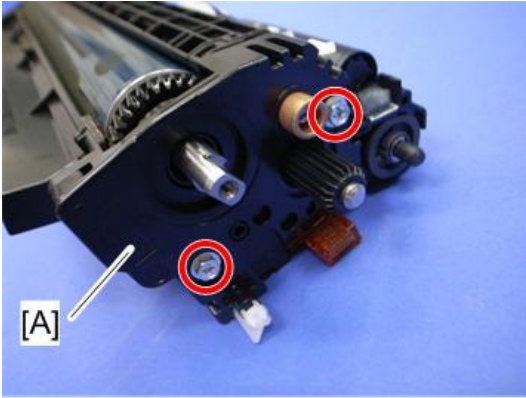

m022r555

4

6. Rear cover [A] (⚙ x 2)



m022r556

7. Remove the screw at the front side.

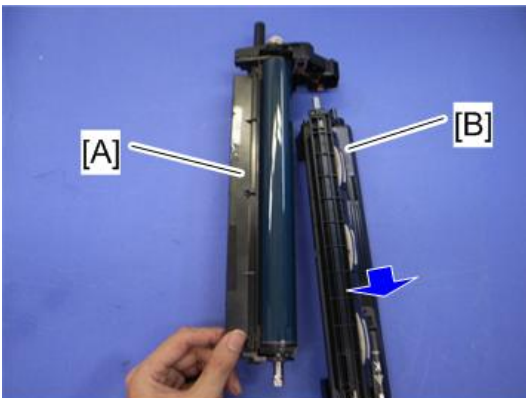

m022r557

8. PCU [A] and development unit [B]

↓ **Note**

- When the development unit is removed from the PCU, clean the entrance mylar [A] with a vacuum cleaner.

When Reinstalling the PCDU

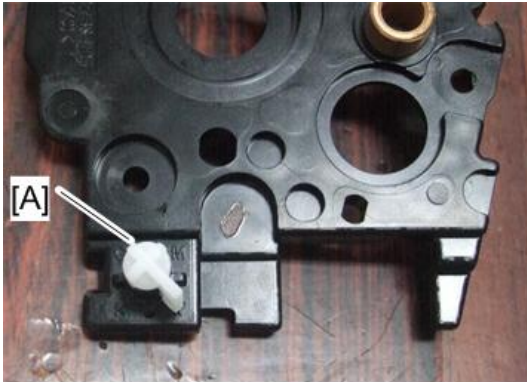

m022r891

1. When you install a new C, M, or Y PCU, make sure that the white switch [A] is at the correct position for the color. On the K PCU, the switch is already at the K position.

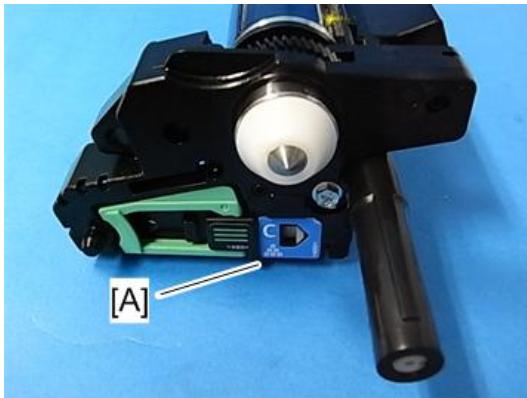

m022r892

2. When you install a new C, M, or Y PCU, attach the decal [A] to the front side of the PCU.
3. Reassemble the machine.
4. If you change the development unit, do the ACC procedure.
5. Execute the drum phase adjustment with SP1902-001 twice.
6. Do the forced line position adjustment
 - First do SP2-111-3 (Mode c).
 - Then do SP2-111-1 (Mode a).

To check if SP 2-111-1 was successful, watch the screen during the process. A message is displayed at the end.

Also, you can check the result with SP 2-194-10 to -12.

Toner Supply Motor

1. Rear cover (page 213)
2. Controller box (page 423)

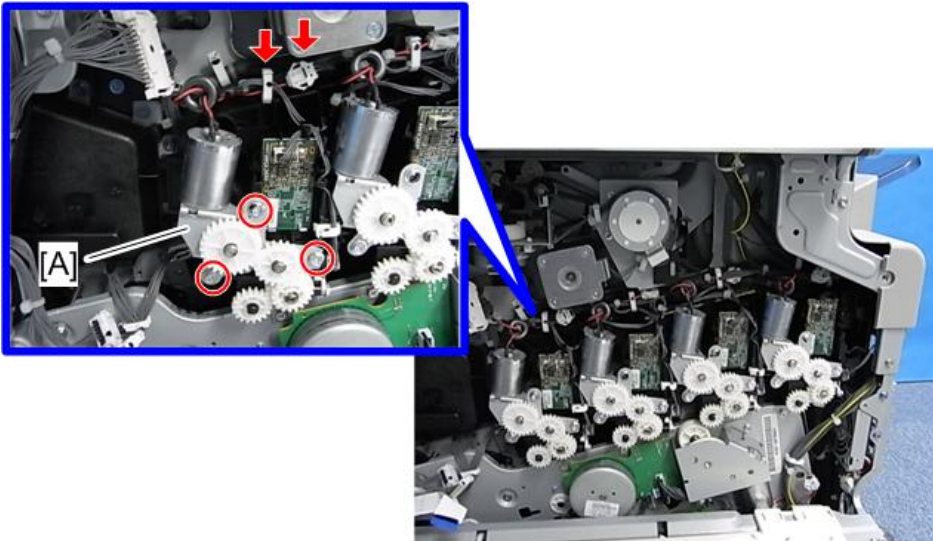

m022r774

3. Motor bracket [A] (x 3, x 1, x 1)

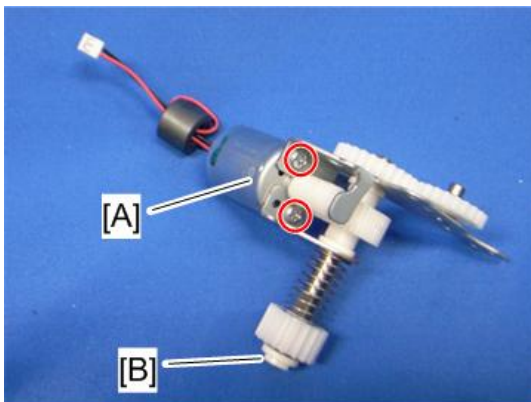

m065r775

4. Toner supply motor [A] (x 2)

Note

- If the bushing (white) [B] is removed with the toner supply motor, install it in the toner hopper frame (as shown below).

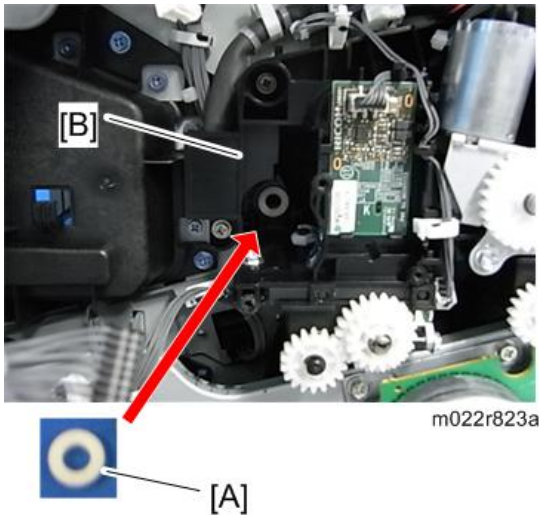
**Note**

- Make sure that the bushing (white) [A] is installed in the toner hopper frame [B].

Toner Collection Motor

1. Inner right lower cover (📄 page 229)
2. Sensor bracket (📄 page 297 "PTR Contact Motor")
3. Interlock switch bracket (📄 page 297 "PTR Contact Motor")
4. Motor bracket (📄 page 297 "PTR Contact Motor")

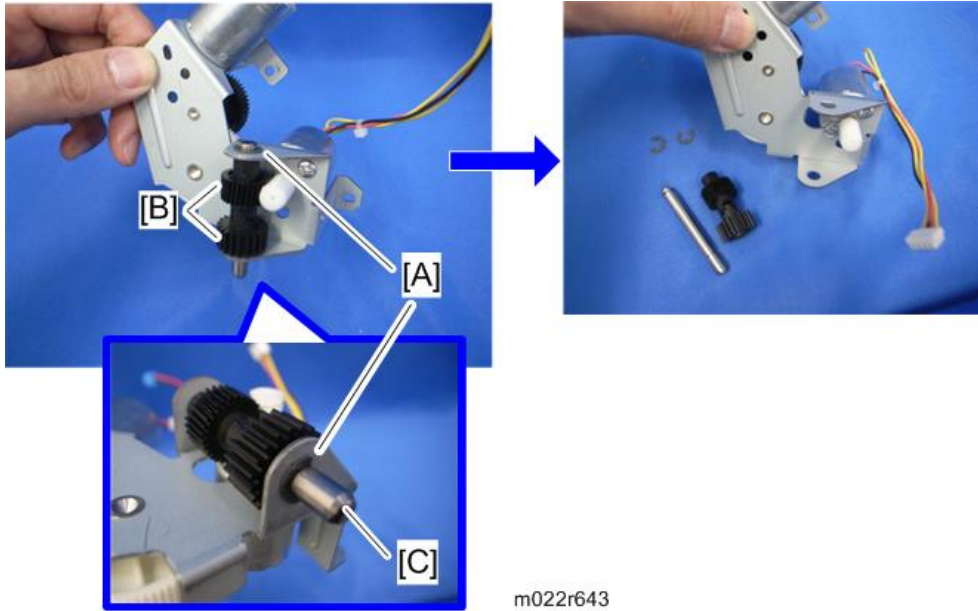

5. Remove the two E-rings [A], the two gears [B], and the shaft [C].

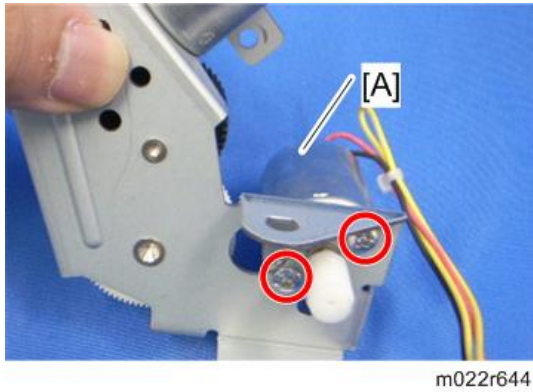

6. Toner collection motor [A] (⌀ x 2)

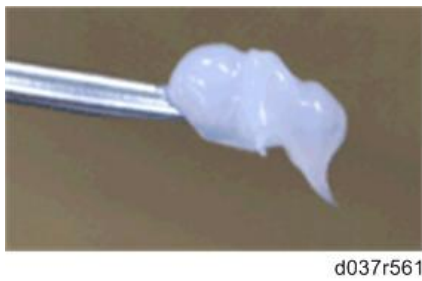

7. Apply a small amount of "Silicone Grease G501" to the gear of the motor as shown above.

Waste Toner Bottle Full Sensor

1. Left cover (page 211)
2. Open the drum securing plate (page 261).

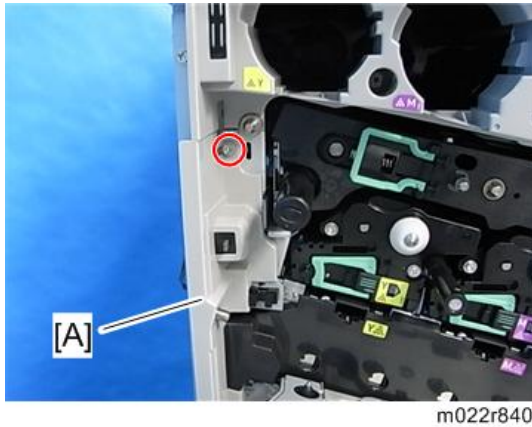

3. Inner left front cover [A] (x 1)

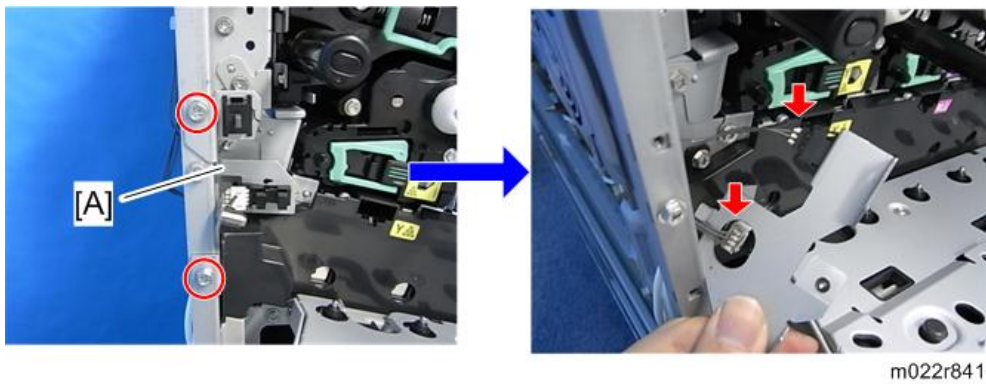

4. Sensor bracket [A] (x 2, x 2)



m022r527

4

5. Waste toner bottle full sensor [A] (hooks)

Waste Toner Bottle Set Sensor

1. Left cover (📄 page 211)
2. Open the drum securing plate (📄 page 261).
3. Sensor bracket (📄 page 273)

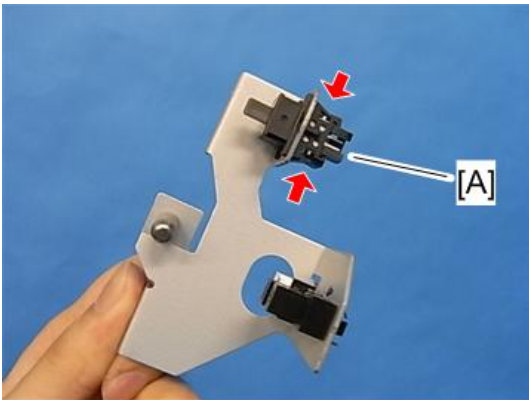

m065r528a

4. Waste toner bottle set sensor [A] (hooks)

RFID CPU Board

1. Rear cover (📄 page 213)
2. Controller box (📄 page 423)
3. Toner hopper unit (📄 page 303)

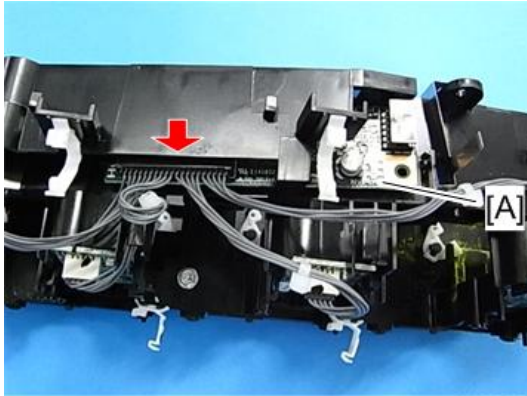

m022r893

4. RFID CPU Board [A] (☞ x 1)

4

RFID Board

1. Rear cover (☞ page 213)
2. Controller box (☞ page 423)

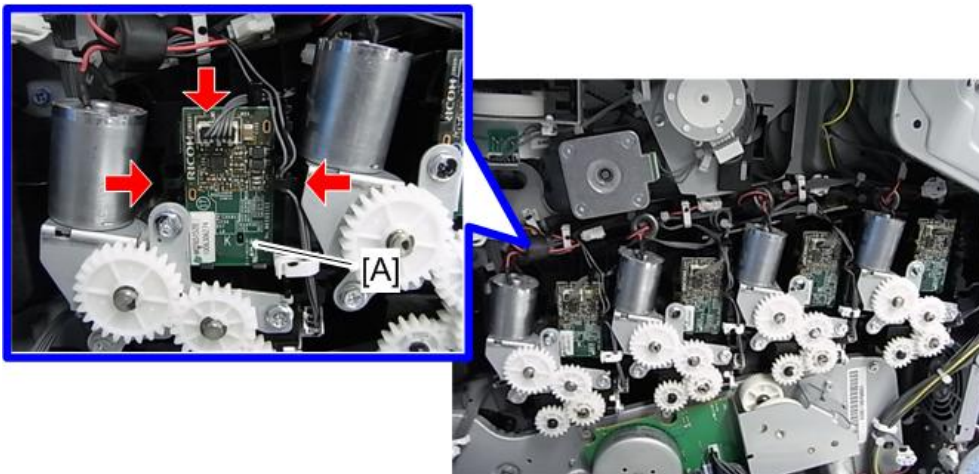

m022r738

3. RFID board [A] (☞ x 1, hooks)

Toner Supply Fan

1. Left cover (☞ page 211)
2. Rear cover (☞ page 213)
3. Open the controller box (☞ page 423).

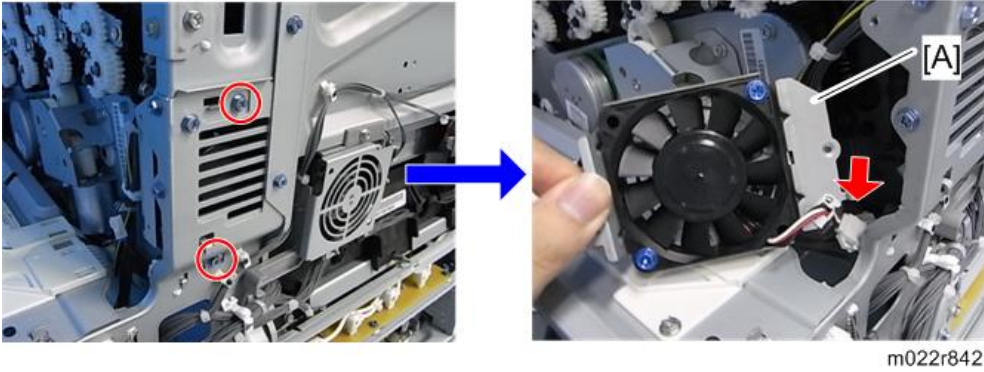

4. Toner supply fan bracket [A] (🔧 x 2, 📏 x 1)

4

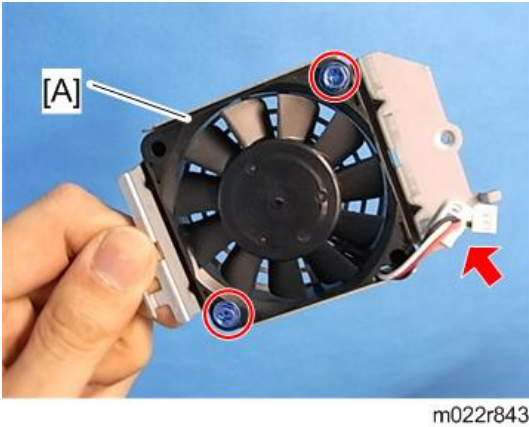

5. Toner supply fan [A] (🔧 x 2, 📏 x 1)

When installing the toner supply fan

Make sure that the toner supply fan is installed with its decal facing the right side.

Image Transfer

ITB (Image Transfer Belt) Unit

If you replace the ITB unit, then you must reset the PM counter for this unit. To do this, set SP 3902 013 to 1 before you start to work on the machine.

1. Open the front door.
2. Toner collection bottle (see page 210)

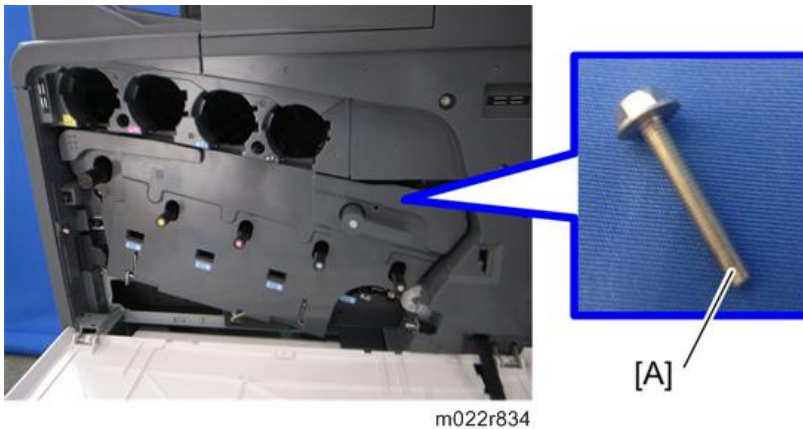

3. Remove the long screw [A].

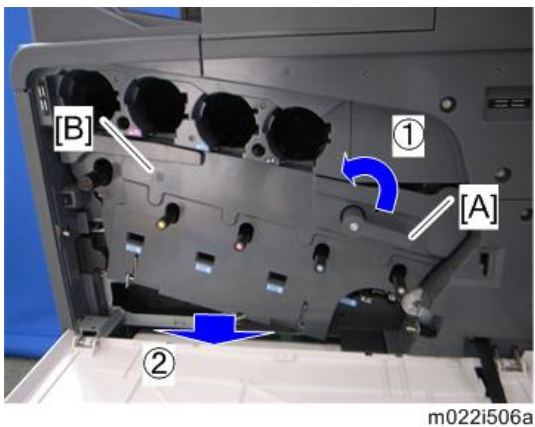

4. Turn the lock lever [A] counterclockwise, and then open the drum securing plate [B].

Note

- Make sure that the lock lever [A] is at home position when reassembling.

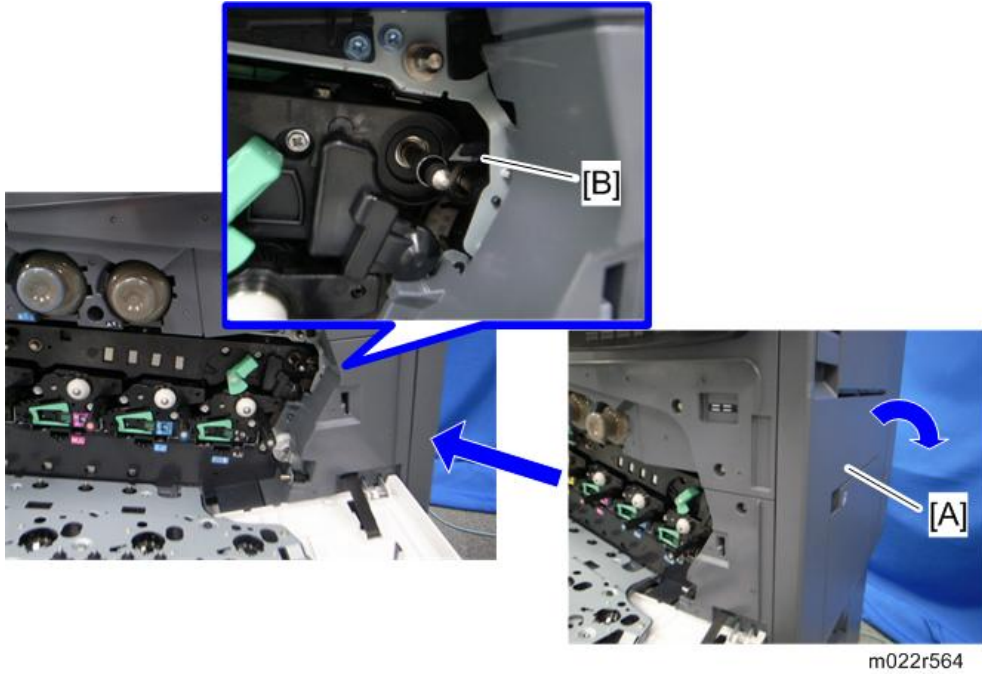

5. Open the duplex unit [A].

- If you open the duplex unit [A], this automatically releases the lock [B] for the ITB unit.

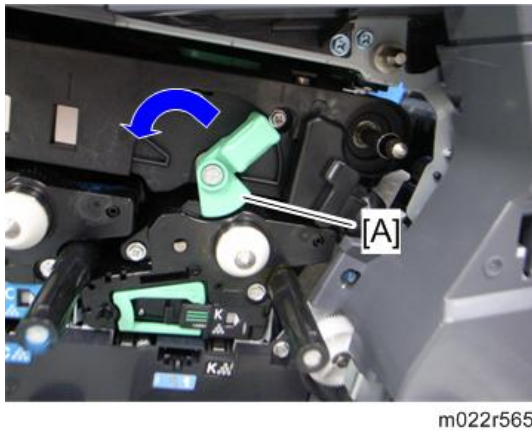

6. Unlock the ITB lock lever [A].

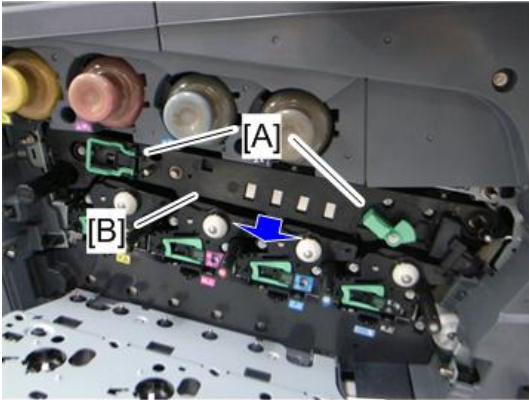

m022r566

7. Grasp the handles [A], and then pull out the ITB unit fully [B].

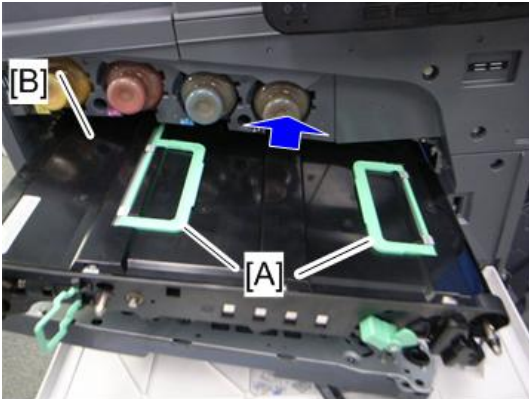

m022r567

8. Grasp the handles [A], and then lift the ITB unit [B].

★ Important

- If it takes much time to reinstall the ITB unit after removing it from the machine, close the paper transfer unit to prevent the drum units from being exposed to light.

Image Transfer Belt, ITB Cleaning Unit

If you replace the TB cleaning unit, then you must reset the PM counter for this unit. To do this, set SP 3902 017 to 1 before you start to work on the machine.

↓ Note

- Do not touch or damage the surface of the image transfer belt during servicing.

1. ITB unit (page 277)

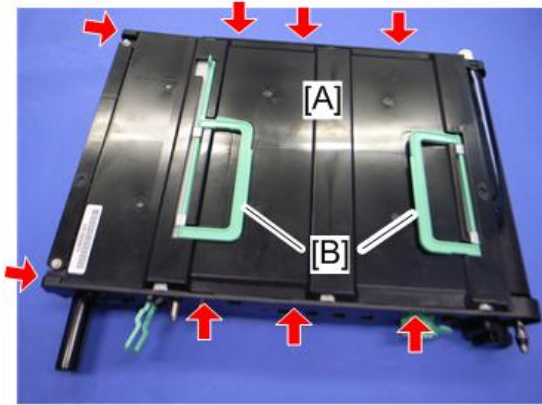

m022r569

4

2. ITB unit cover [A] and the handles [B] (8 hooks).

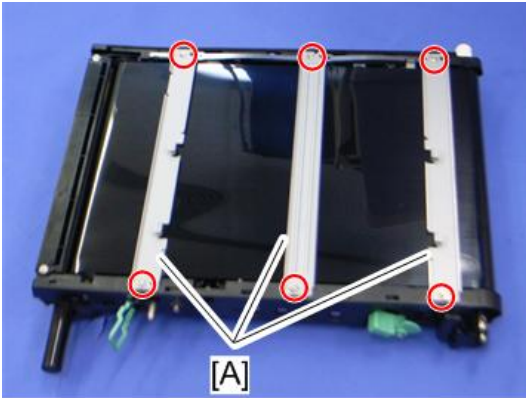

m022r568

3. Three stays [A] (⚙ x 2 each)

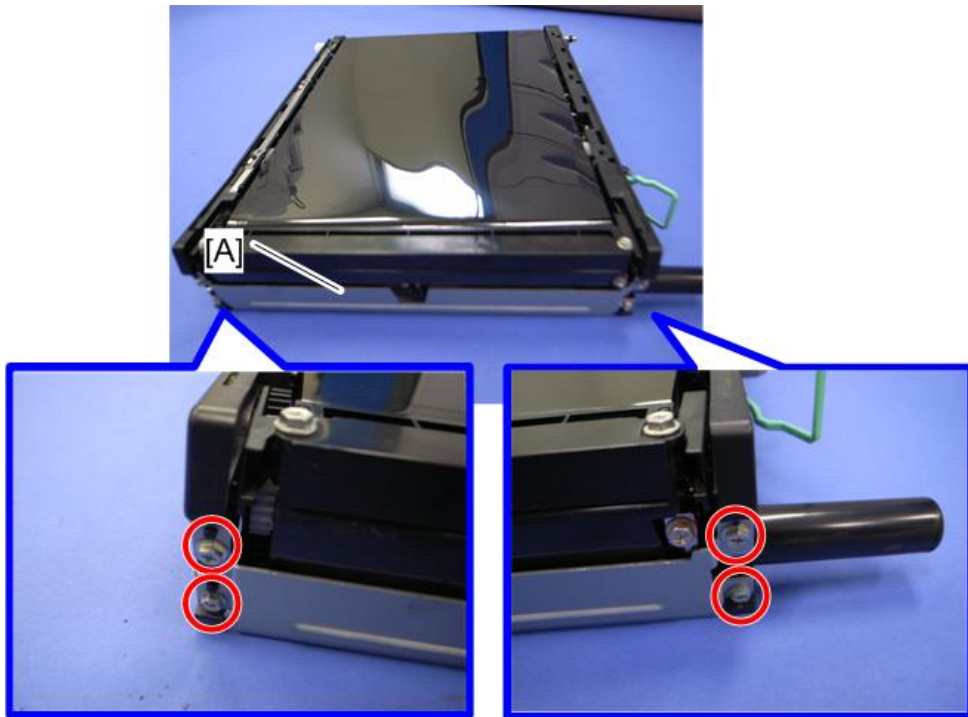

m022r570

4. The left stay [A] (🔩 x 4)



m022r572

5. Rear holder bracket [A] (🔩 x 2)

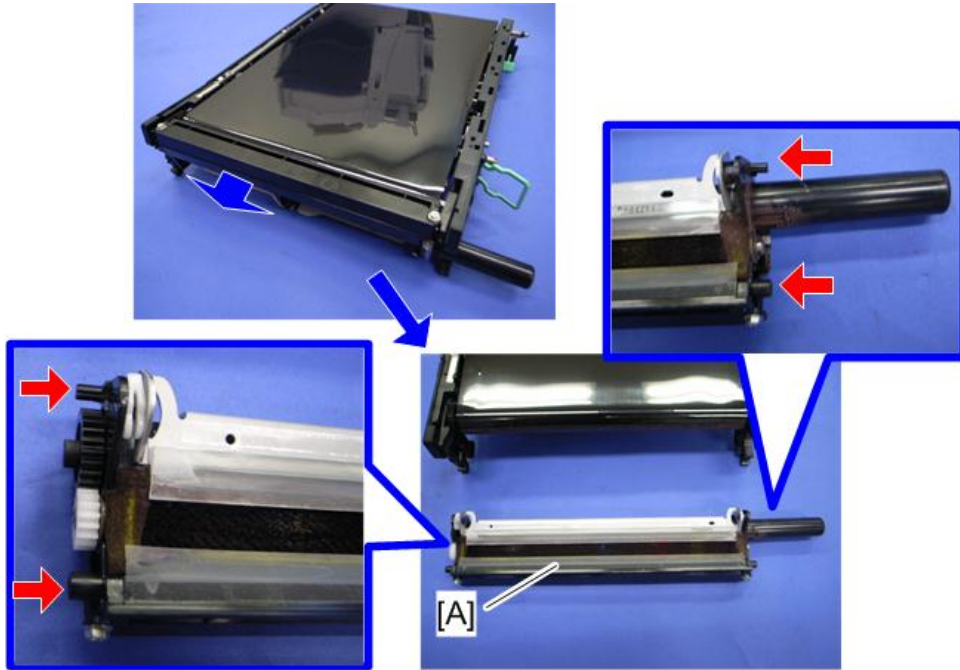

m022r571

6. ITB cleaning unit [A]

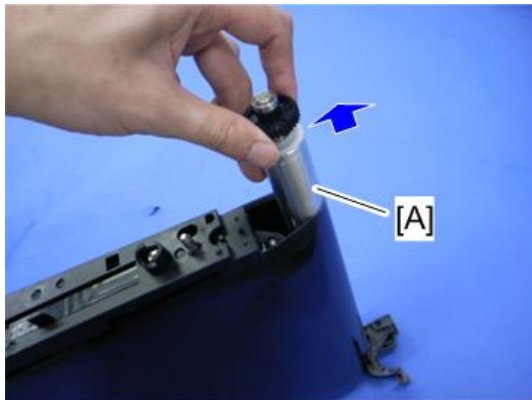

m022r574

7. Pull the tension roller [A] as shown above.

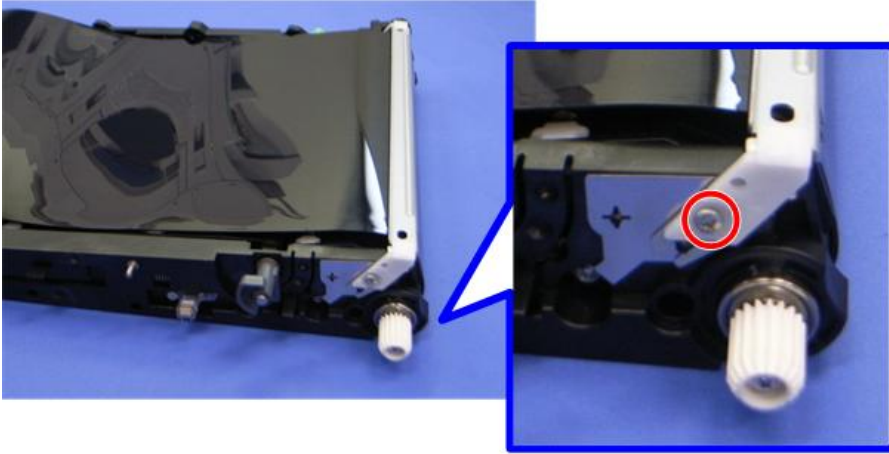

m022r575

8. Remove a screw.

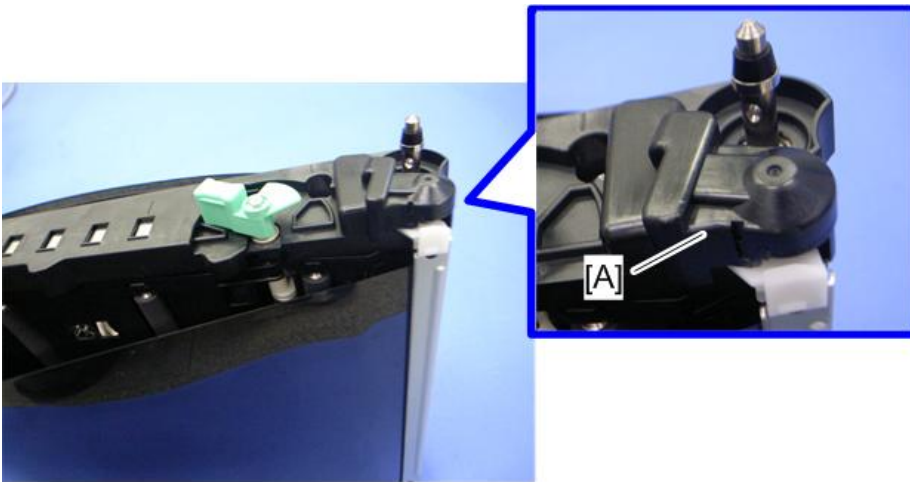

m022r576

9. Front holder bracket [A]

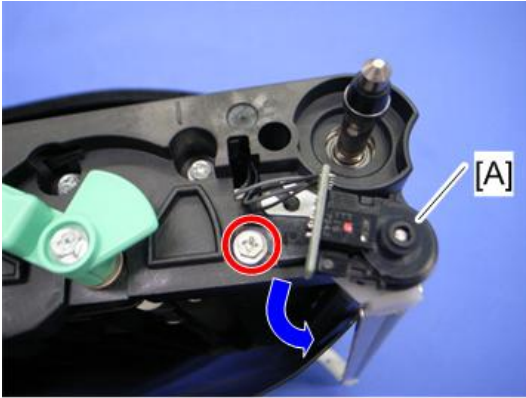

m022r577

4 10. Remove a screw, and then turn the encoder sensor [A] to the left.

Note

- When replacing the image transfer belt, work carefully to avoid damaging the encoder sensor [A].

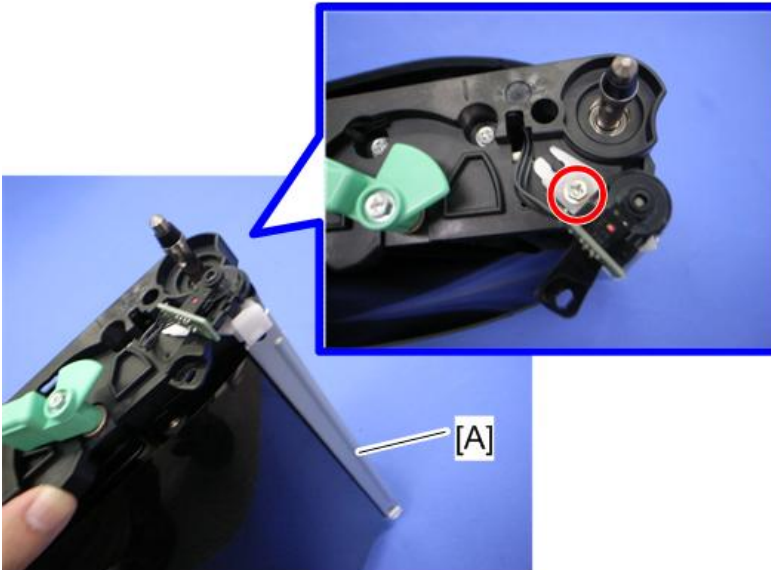

m022r578

11. The right stay [A] (🔩 x 1)

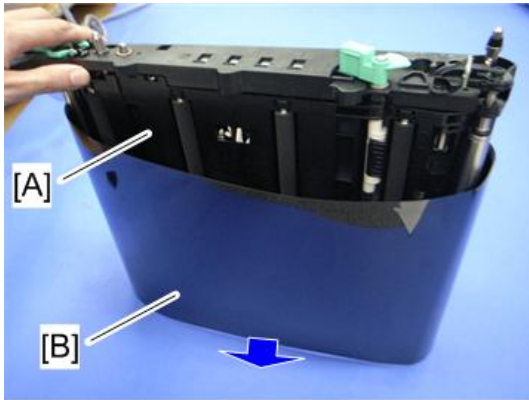

m022r579

12. Stand the ITB unit [A] as shown above.
13. Image transfer belt [B]

4

When Installing the Image Transfer Belt

- Reset the PM counter

↓ Note

- The image transfer belt does not have any directional characteristics. When installing the image transfer belt, it is not required to install the image transfer belt in a specific orientation.

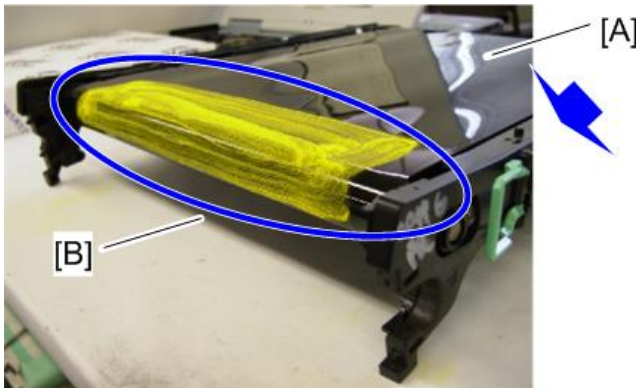

m065r800

1. Lubricate a part of the surface of the image transfer belt [A] with yellow toner, and then turn the image transfer belt to the position [B] as shown above.

↓ Note

- Be sure to use yellow toner from the d190/d193; do not use lubricant powder, developer, or waste toner.
- You can also use the provided service part: D0159500 (G104 Yellow Toner)

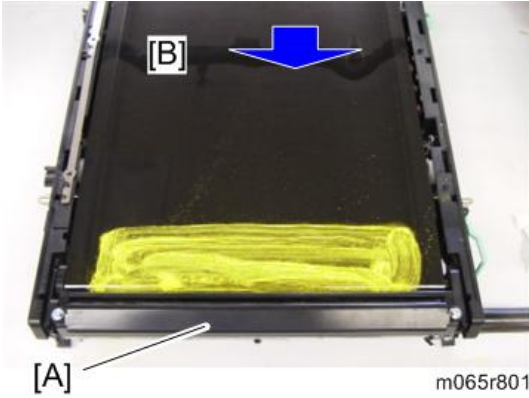

4

2. Install the ITB cleaning unit [A], and then collect the yellow toner by turning the image transfer belt [B].

ITB Encoder

1. ITB unit (see page 277)

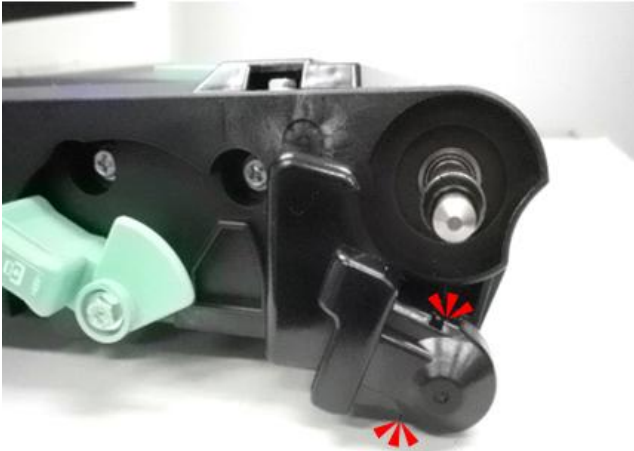

d190b0401

2. Remove the encoder cover (Hook x2).

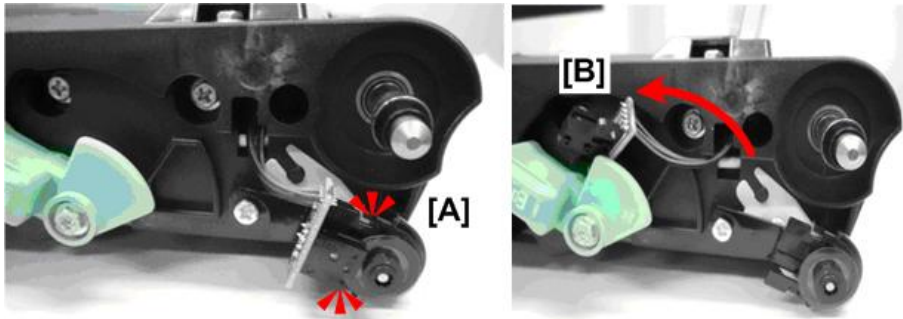

d190b0402

3. Separate encoder sensor [A] from its bracket (Hook x2).
4. Set sensor [B] on the green lever.

4

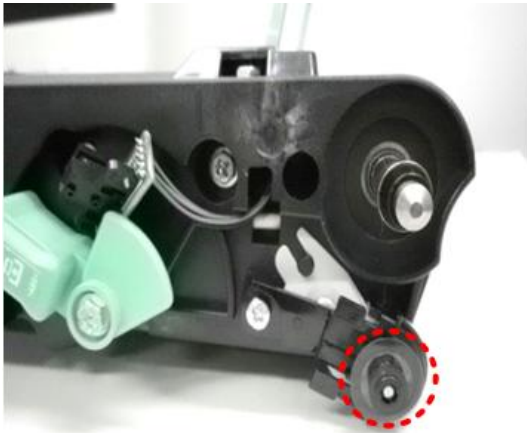

d190b0403

5. Remove the encoder collar.

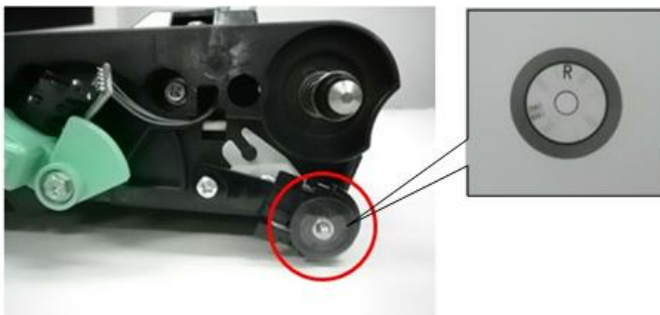

d190b0404

6. Carefully, remove the encoder disk.

★ Important

- Remove and handle the disk with care to avoid bending or scratching it.
- Lay to disk on a flat clean surface to keep the disk surface clean.

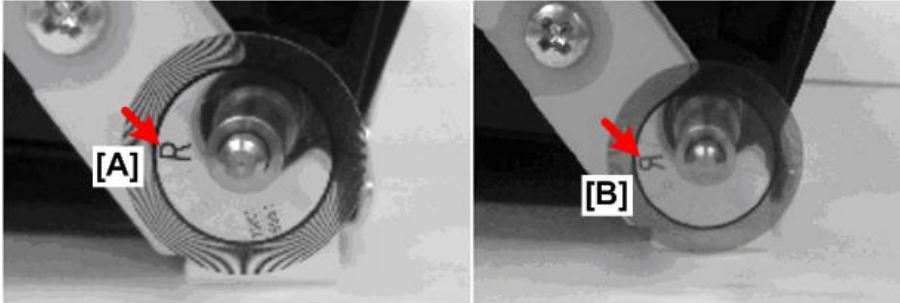

d190b0405

★ Important

- Be sure to re-attach the disk correctly. The letter "R" [A] must be clearly visible and oriented correctly, not reversed [B]. If the letter appears reversed, remove the disk, turn it over, and re-attach it so it looks like [A].

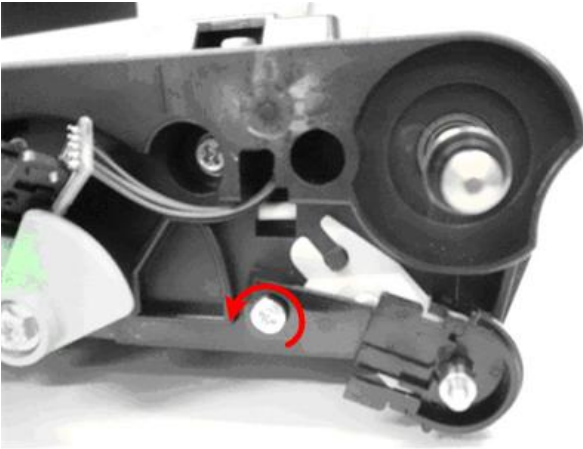

d190b0406

7. Remove the screw.

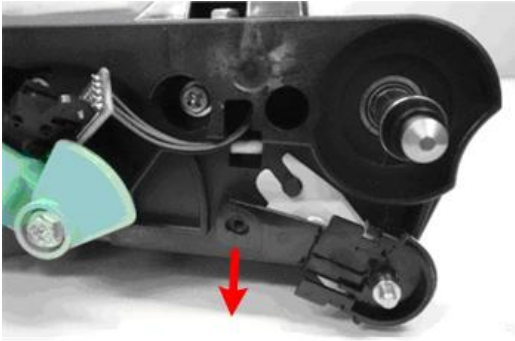

d190b0407

8. Lower and then remove the encoder holder.
9. Remove the ITB (page 279).



d190b0408

10. Loosen (do not remove) the two screws.

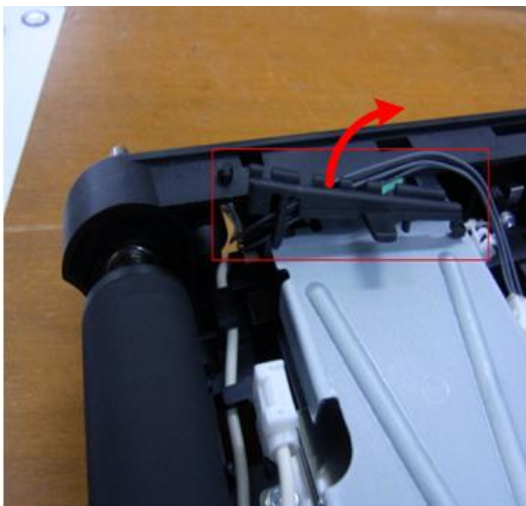

d190b0409

11. Remove the harness cover.

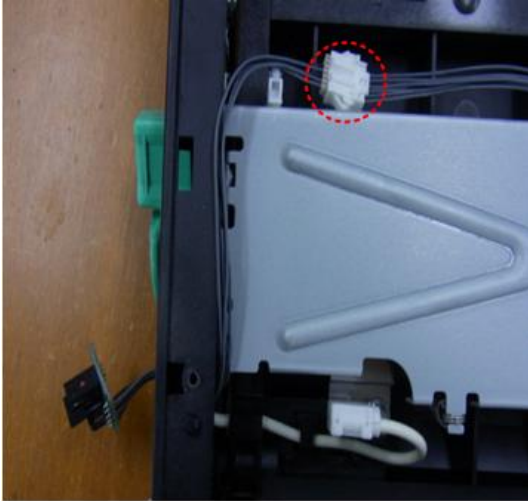

d190b0410

12. Disconnect the old sensor and remove it (🔧 x1).

★ Important

- After the ITB encoder sensor is replaced, the machine automatically resets the PM counter for the ITB unit to zero. This is the same as installing a new unit.

ITB Contact Motor

1. Rear cover (🔧 page 213)
2. Open the controller box (🔧 page 423).

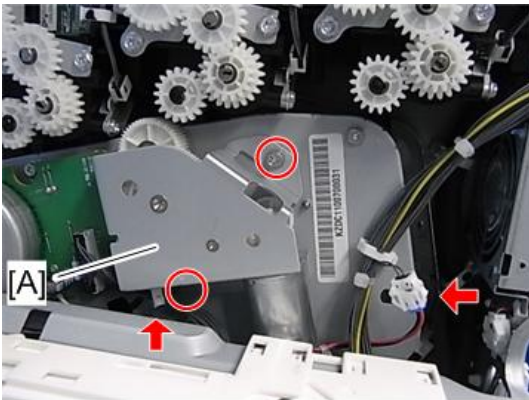

m022r558a

3. ITB contact motor unit [A] (🔧 x 2, 🛠️ x 1, 🛠️ x 1)

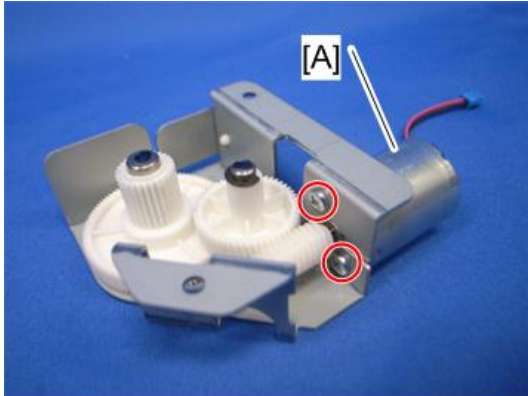

m065r773

4. ITB contact motor [A] (🔧 x 2)

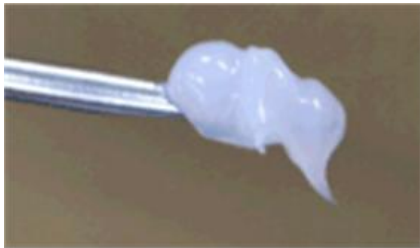

d037r561

5. Apply a small amount of "Silicone Grease G501" to the gear of the motor as shown above.

ITB Contact Sensor

1. PCDU: K (🔧 page 261)
2. Rear cover (🔧 page 213)
3. Controller box (🔧 page 423)

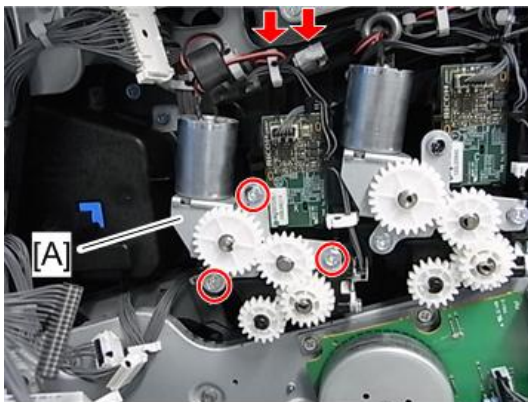

m022r739a

4. Toner supply bracket: K [A] (🔩 x 3, 📏 x 1, 🛠️ x 1)

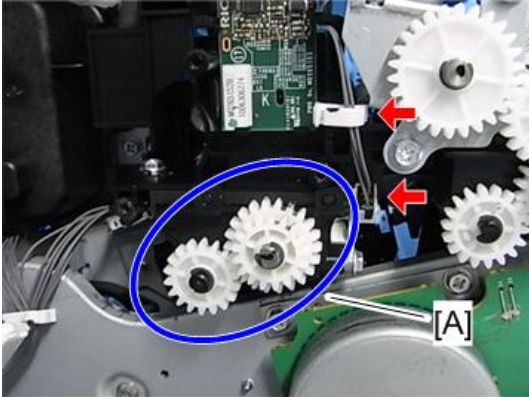

m022r740

5. Release the toner tube: K [A] by pulling out its gear assembly a short distance (📏 x 1, 🛠️ x 1).

Note

- Work carefully when releasing the toner supply tube [A] to avoid spilling toner on clothing or the hands.

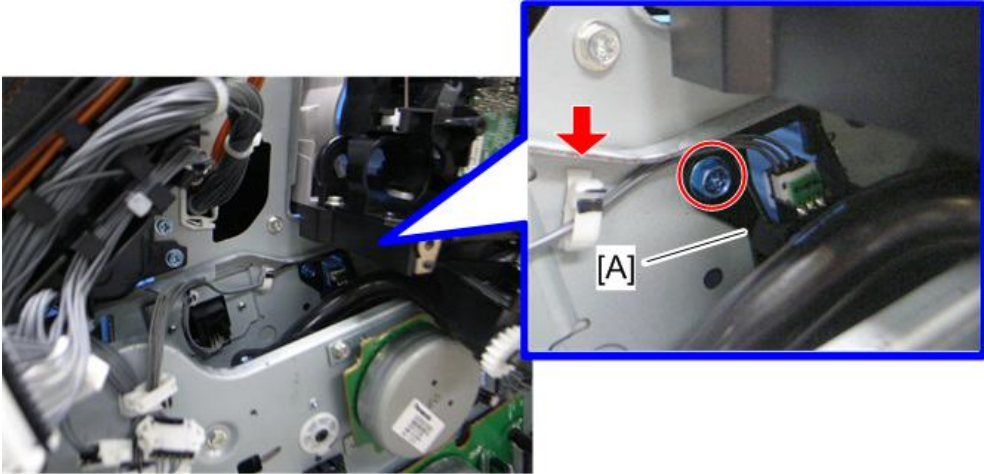

m065r741

6. Sensor holder [A] (🔩 x 1, 🛠️ x 1)

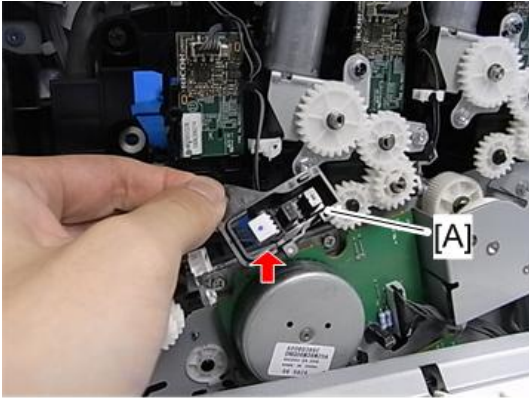

m022r742

7. ITB contact sensor [A] (🔧 x 1, hooks)

4

ID Sensor Board

1. Fusing unit (🔧 page 322)

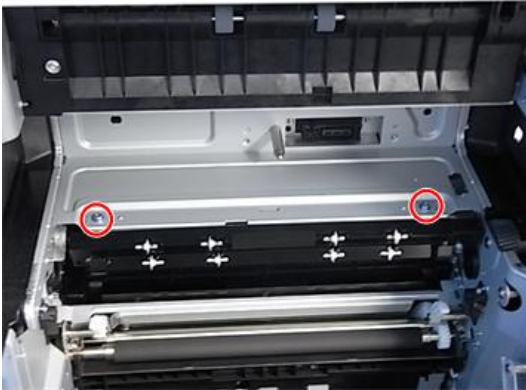

m022r545a

2. Remove the two screws.

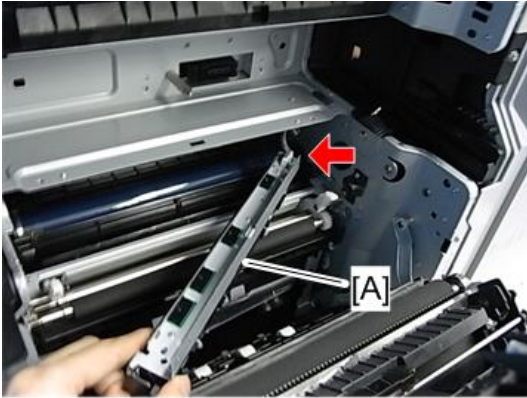

m022r546a

4

- 3. ID sensor board bracket [A] (🔩 x 1)

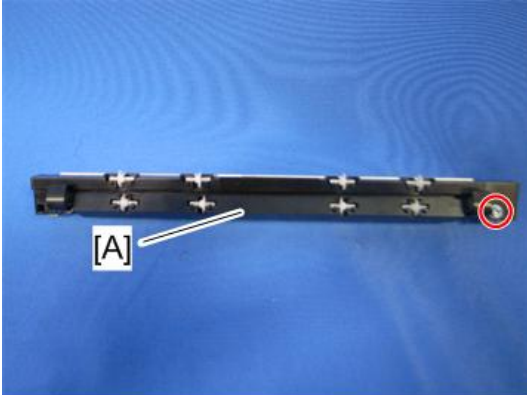

m065r547

- 4. ID sensor board cover [A] (🔩 x 1)

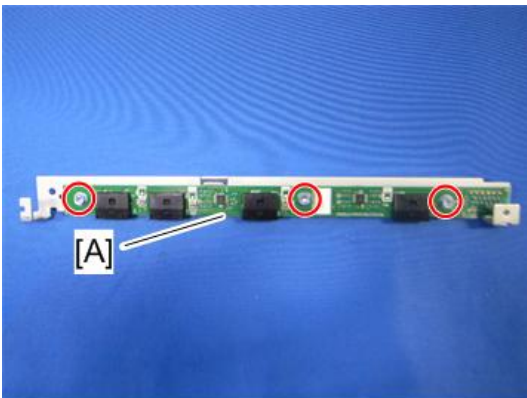

m065r548

- 5. ID sensor board [A] (🔩 x 3)

After installing a new ID sensor board

Do the following adjustment after installing a new ID sensor board.

1. Plug in and turn on the main power switch of the machine.
2. Enter the SP mode.

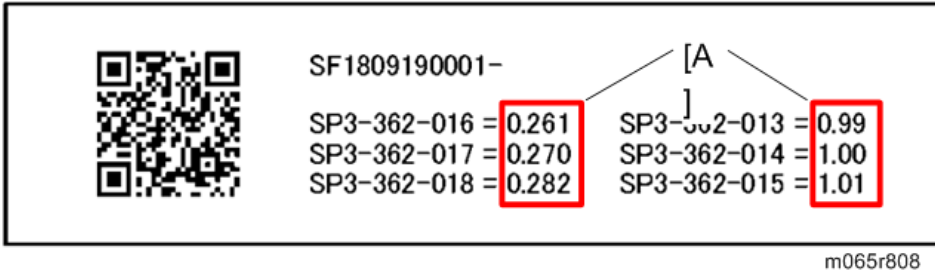

3. Input all correction coefficients [A] for the ID sensor with the SP modes referring to the barcode sheet provided with the new ID sensor board.

Note

- For example, input "0.99" with SP3-362-013.

4. Exit the SP mode.

Paper Transfer

PTR (Paper Transfer Roller) Unit

- If you install a new PTR unit, then set SP 3902-018 to "1" before you start this procedure.

Note

- If you do this, then the machine will reset the PM counter for the paper transfer unit automatically, after you turn the power on again.

1. Open the duplex unit.

4

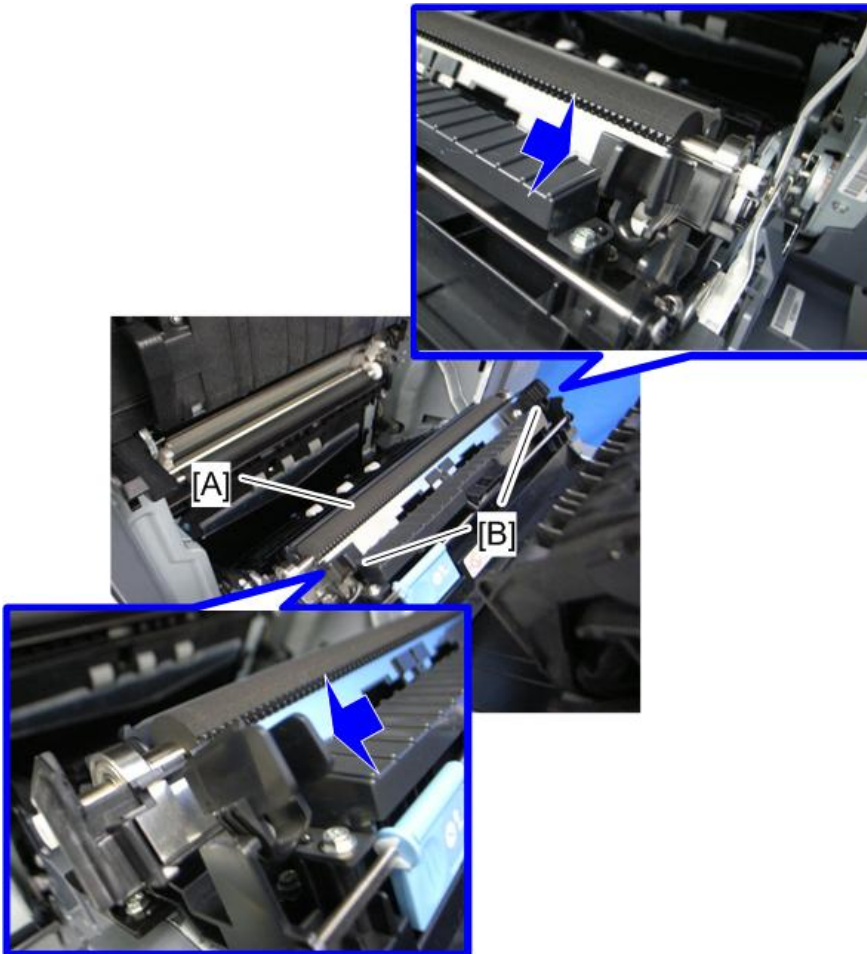

m022r580

2. Remove the PTR unit [A], releasing the two locks [B].

When Installing the PTR Unit

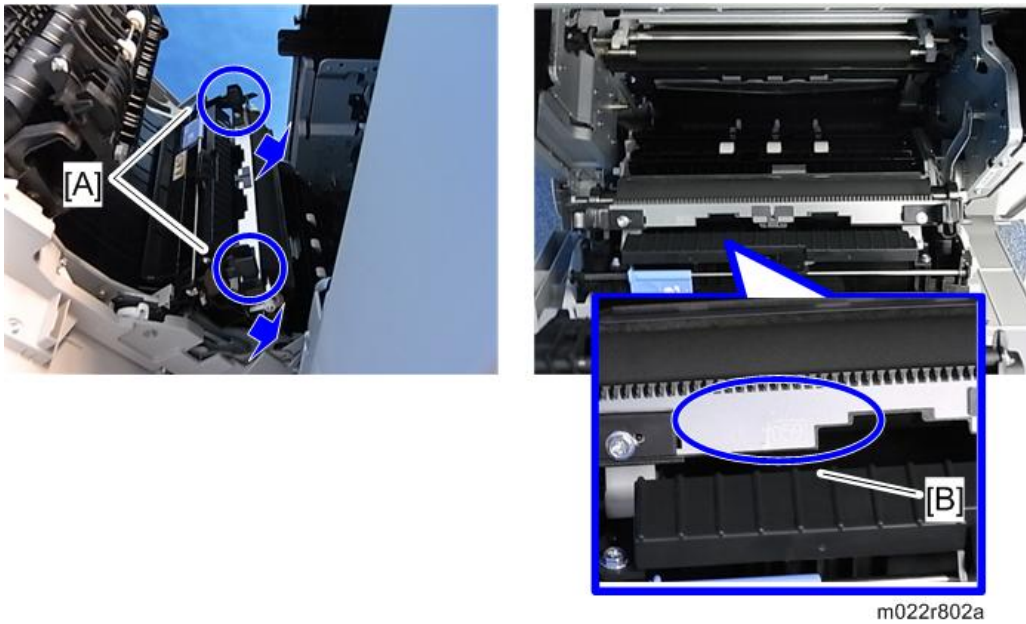

4

To install the PTR unit, pinch the two green locks [A] while you push the unit back into position.

Do not insert objects between the metal plate [B] and its black plastic base. Otherwise, the plate could be bent, and this can cause poor image quality.

PTR Contact Motor

1. Inner right lower cover (🔧 page 229)

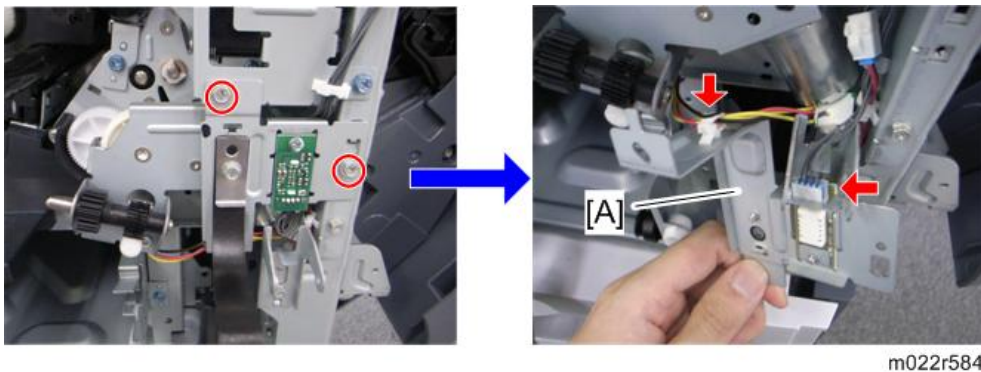

2. Sensor bracket [A] (🔧 x 2, 📏 x 1, 📏 x 1)

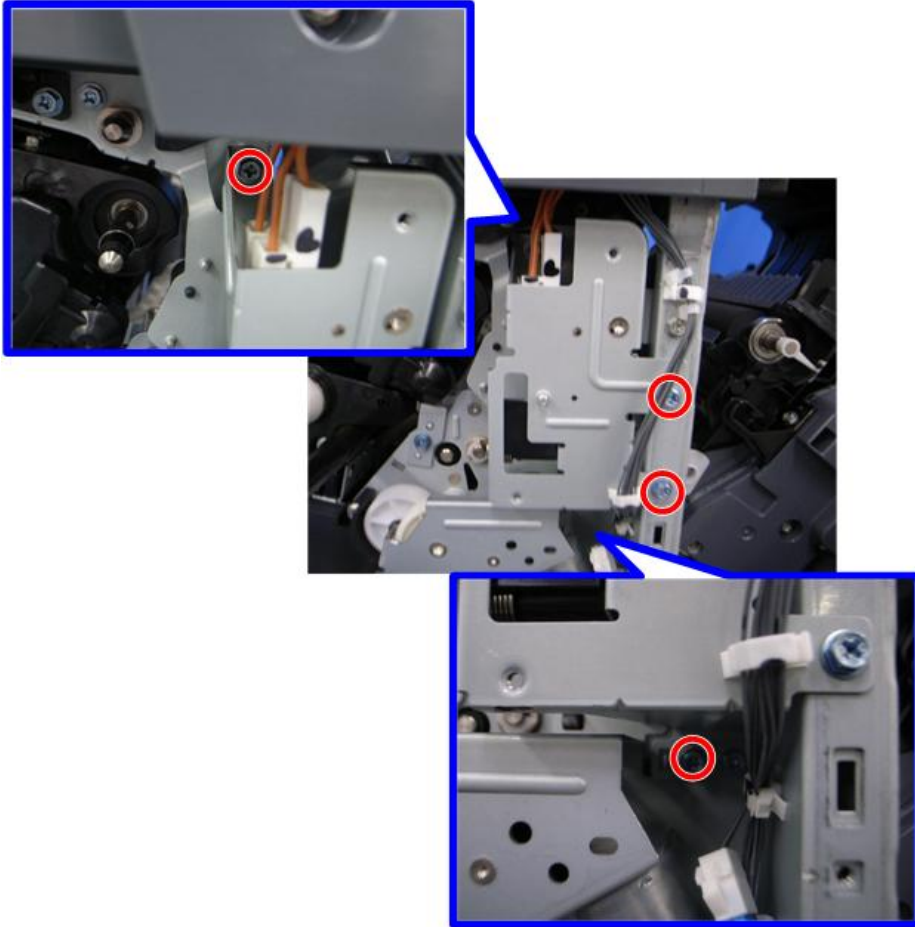

m022r585

3. Remove four screws.

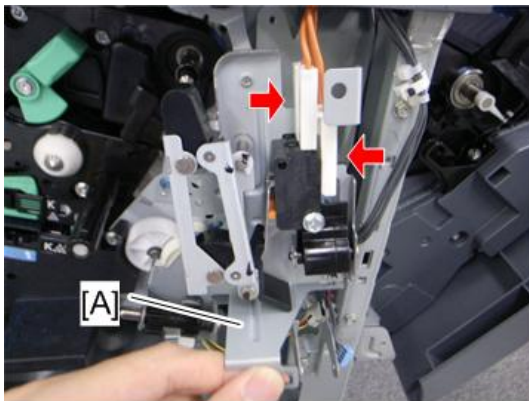

m022r586

4. Interlock switch bracket [A] (☞ x all)

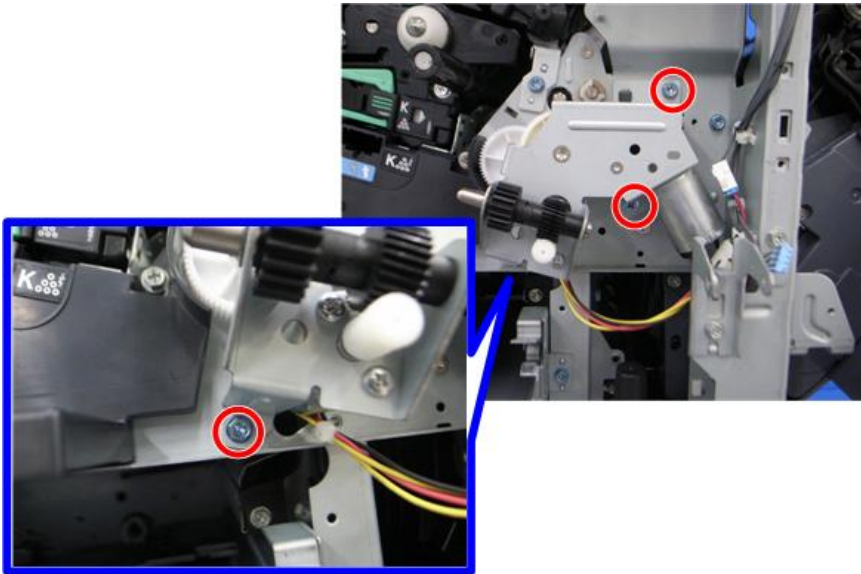

m022r587

5. Remove three screws.

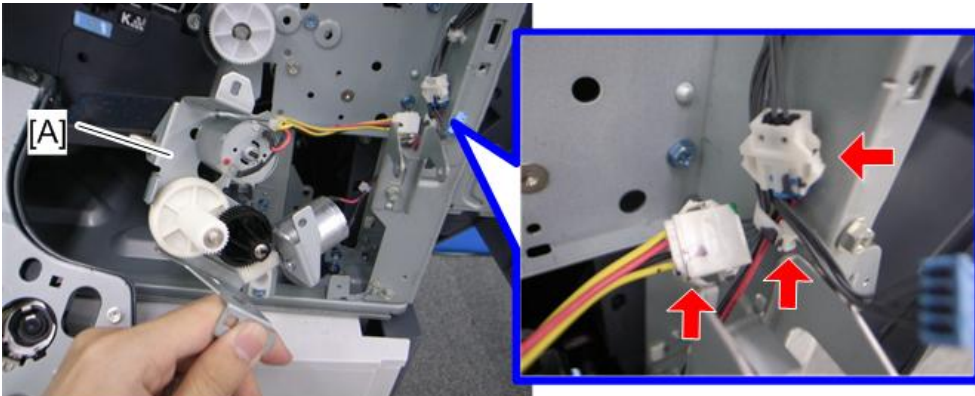

m022r588

6. Motor bracket [A] (🔧 x 1, 📦 x 2)

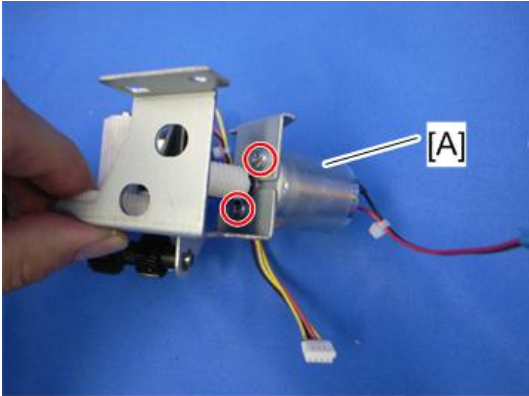

m022r589

4

7. PTR contact motor [A] (2 x 2)

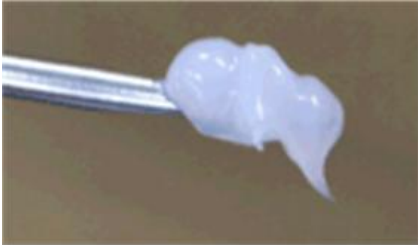

d037r561

8. Apply a small amount of "Silicone Grease G501" to the gear of the motor as shown above.

PTR Contact Sensor

1. Rear cover (see page 213)
2. Motors with bracket (see page 312)

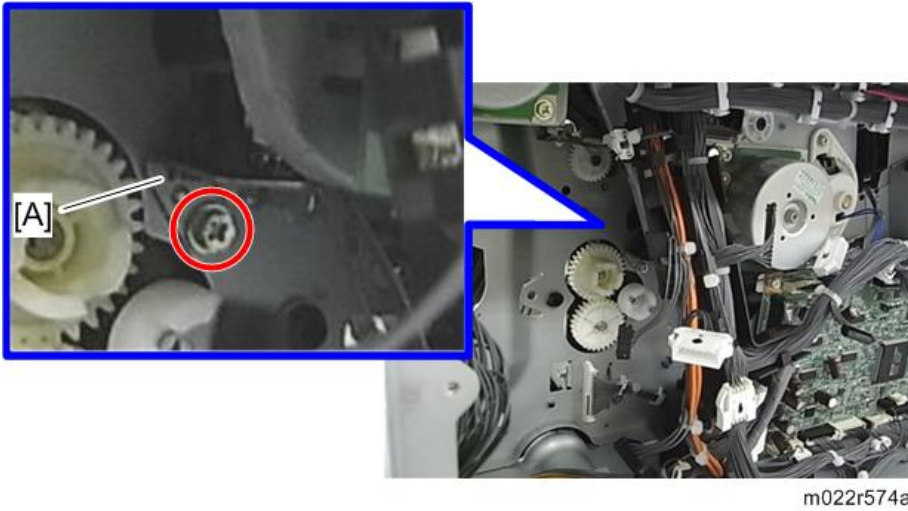

m022r574a

4

3. Sensor bracket [A] (🔩 x 1)

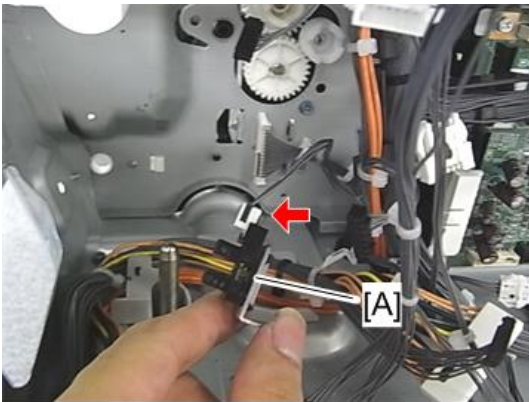

m022r575a

4. PTR contact sensor [A] (🔌 x 1, hooks)

Temperature and Humidity Sensor

1. Inner right cover (🔧 page 226)

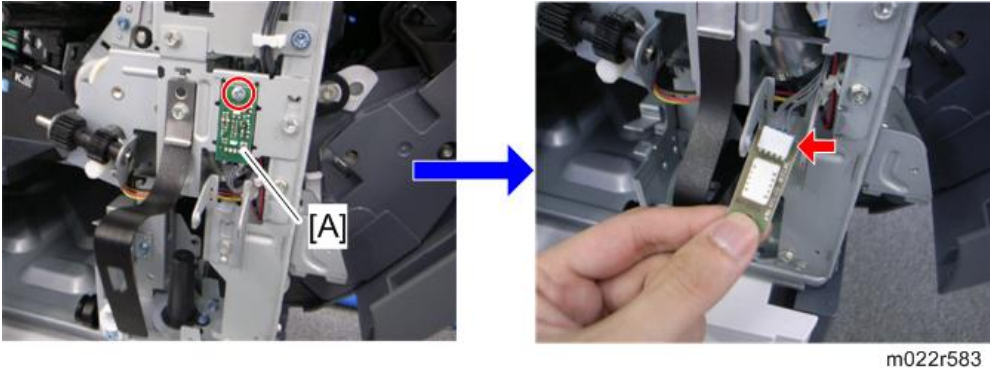

m022r583

2. Temperature and humidity sensor [A] (🔧 x 1, 📱 x 1)

Drive Unit

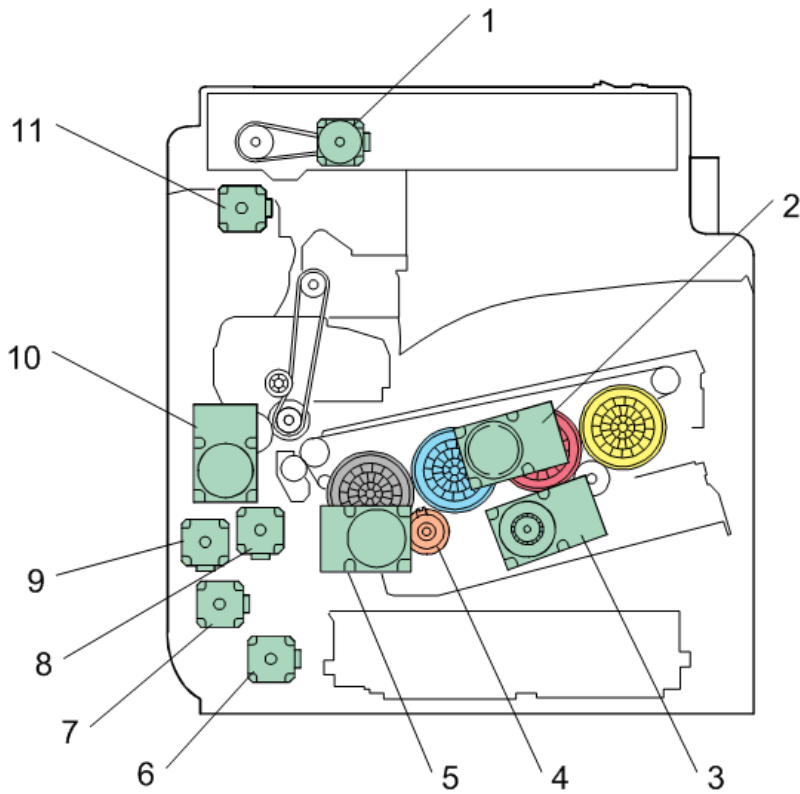

m022v103

The drawing above shows the drive unit layout.

1. Scanner motor	6. Paper feed motor
2. Drum motor: CMY	7. Vertical transport motor
3. Development motor: CMY	8. Registration motor
4. Development clutch: K	9. Duplex/ By-pass motor
5. ITB Unit/ Drum: K/ Development : K motor	10. Fusing/paper exit motor
	11. Inverter motor

Gear Unit

1. Pull out the toner bottles.
2. ITB unit (🖨️ page 277)

- 3. PCDU (page 261)
- 4. Rear lower cover (page 212)
- 5. Rear cover (page 213)
- 6. Right rear cover (page 214)
- 7. Controller box (page 423)

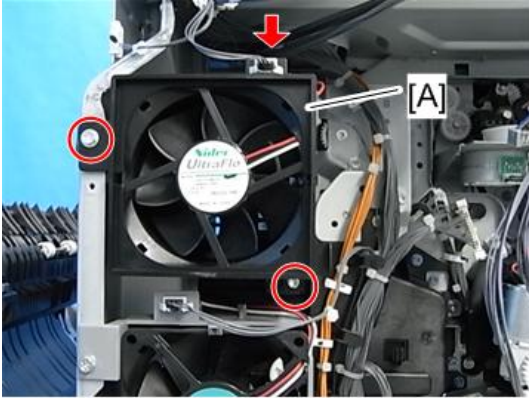

m022r847

- 8. Fusing rear fan base [A] (x 2, x 1)

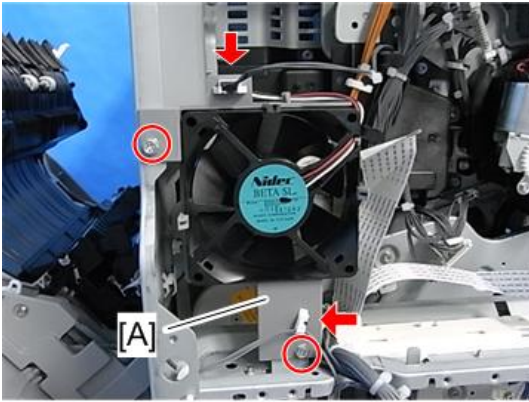

m022r848

- 9. Drive unit fan base [A] (x 2, x 1, x 1)
- 10. PSU box (page 443)

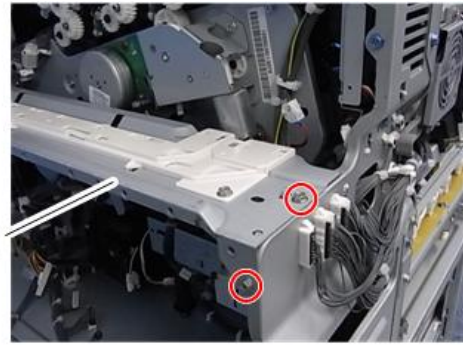
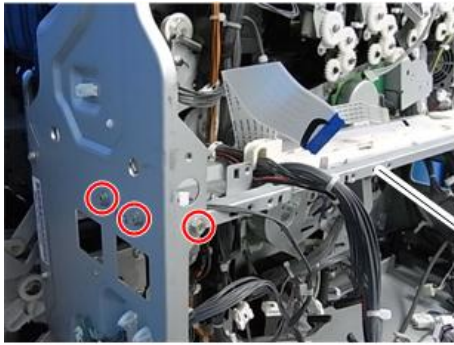

m022r849

11. Remove the five screws for stay [A].

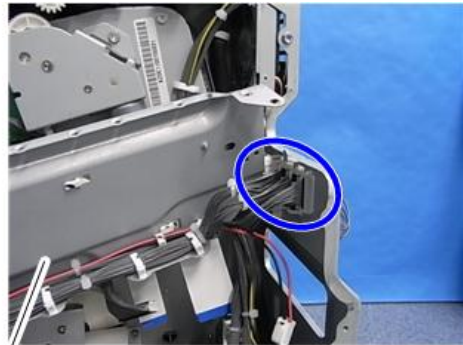
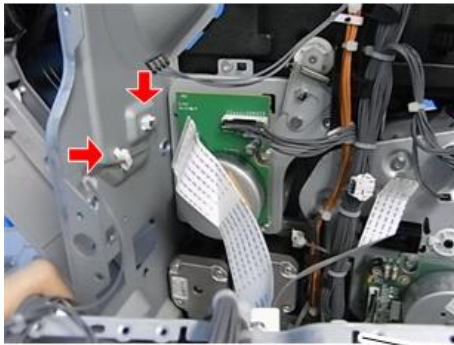

m022r850

12. Stay [A] (🔩 x 4, 🛠 x 1)

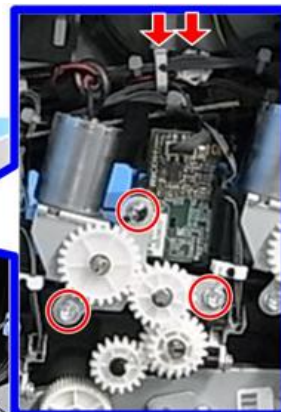
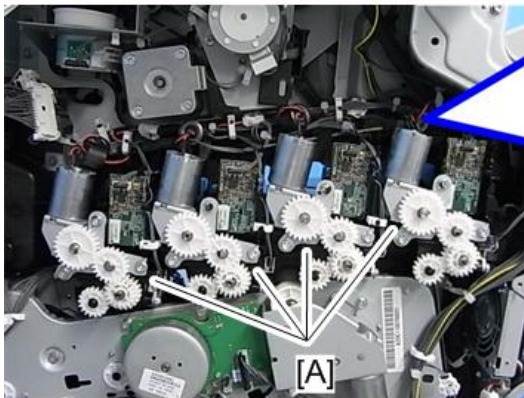

m022r851

13. Toner supply motor brackets [A] (🔩 x 3, 🛠 x 1, 🛠 x 1 each)

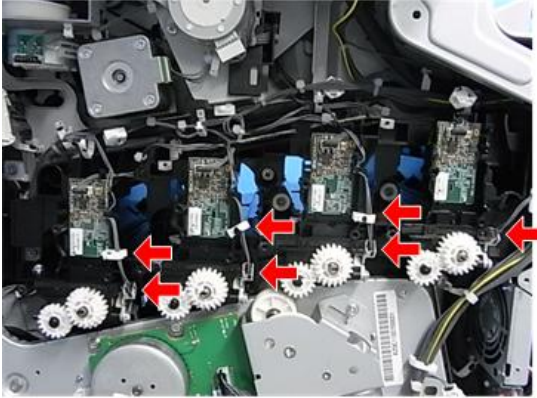

m022r852

4

14. Release the three clamps and disconnect the four connectors.

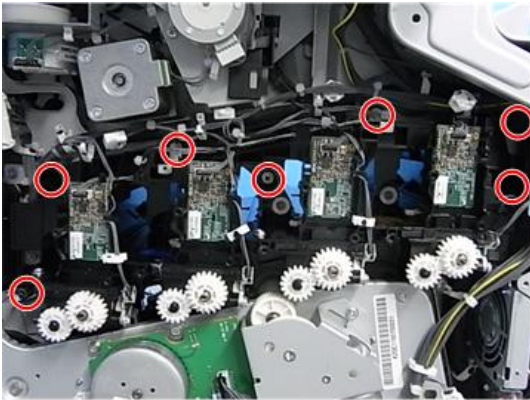

m022r854

15. Toner hopper unit (🔧 x 7, 🖨️s, 🖨️s)

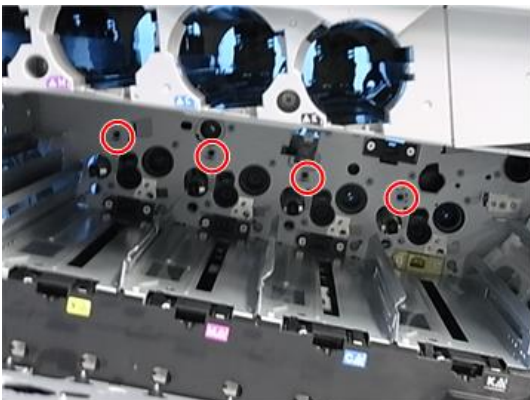

m022r853

16. Remove the four clips for the toner supply tubes.

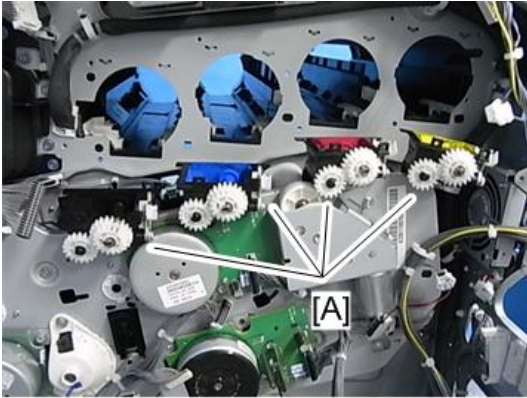

m022r855

17. Toner supply tubes [A]

⬇ Note

- Work carefully when removing the toner supply tube [A] to avoid spilling toner on clothing or the hands.

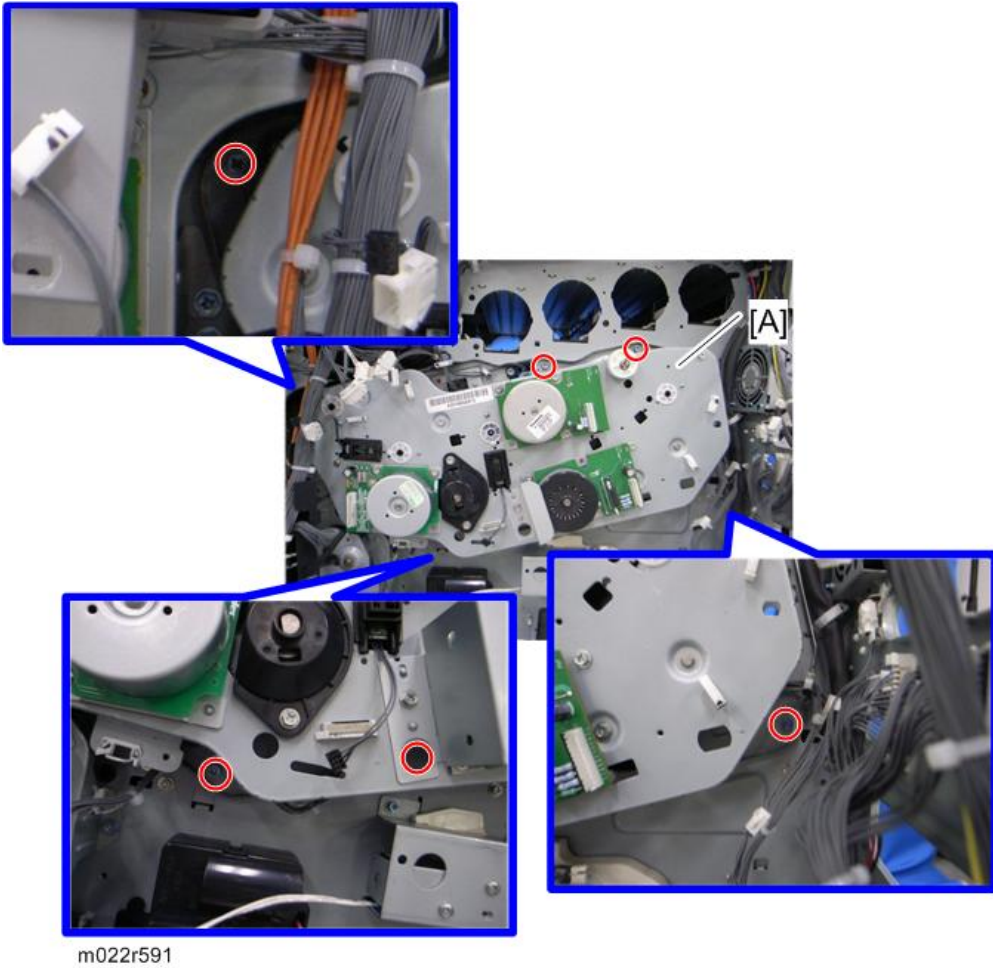

18. Gear unit [A] (🔧 x all, 🛠️ x all, 🔩 x 6)

Drum Motor: CMY

1. Rear cover (🔧 page 213)
2. Rear lower cover (🔧 page 212)
3. Right rear cover (🔧 page 214)
4. Controller box (🔧 page 423)
5. Fusing rear fan base (🔧 page 303 "Gear Unit")
6. Drive unit fan base (🔧 page 303 "Gear Unit")
7. PSU box (🔧 page 443)
8. Stay (🔧 page 303 "Gear Unit")

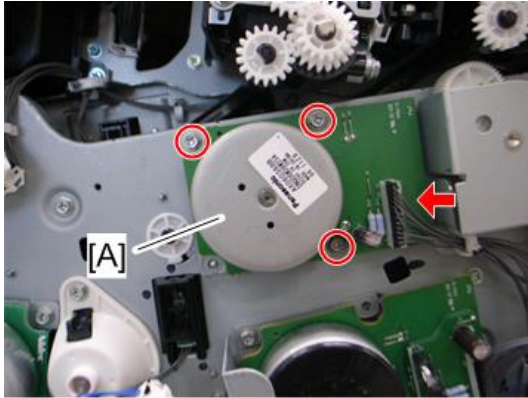

m065r512

9. Drum motor: CMY [A] (🔩 x 3, 📌 x 1)

4

Development Motor: CMY

1. Rear lower cover (📄 page 212)
2. Right rear cover (📄 page 214)
3. PSU box (📄 page 443)

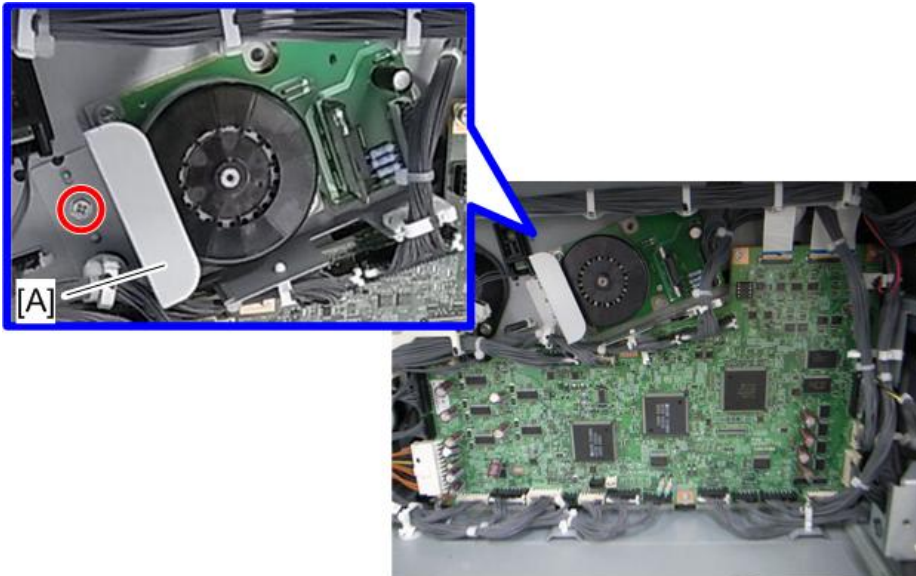

m022r592

4. Remove the bracket [A] (🔩 x 1).

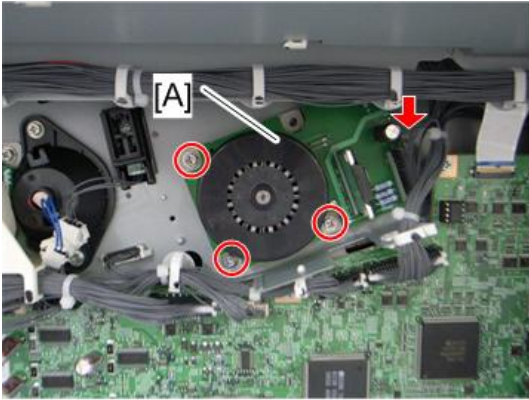

m022r593

4

- 5. Development motor: CMY [A] (🔧 x 3, 📁 x 1)

ITB Unit/ Drum: K/ Development: K Motor

- 1. Rear lower cover (📄 page 212)
- 2. Right rear cover (📄 page 214)
- 3. PSU box (📄 page 443)



m022r594

- 4. Harness guide [A] (🔧 x 1)

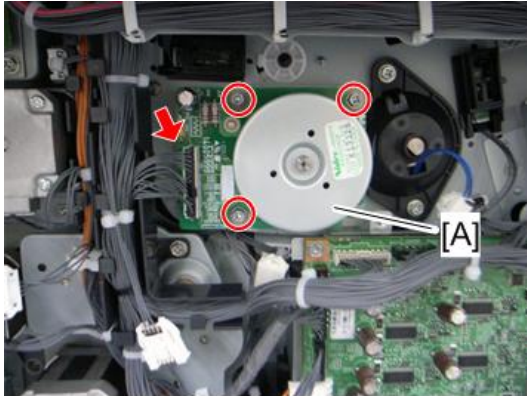

m022r595

5. ITB unit/ Drum: K/ Development :K motor [A] (⚙️ x 3, 📁 x 1)

4

Development Clutch: K

1. Rear lower cover (📄 page 212)
2. Right rear cover (📄 page 214)
3. PSU box (📄 page 443)
4. ITB unit/ Drum: K/ Development :K motor (📄 page 310)

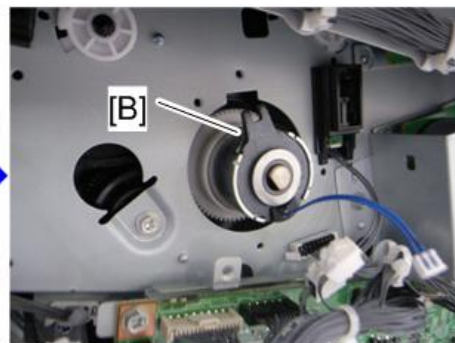
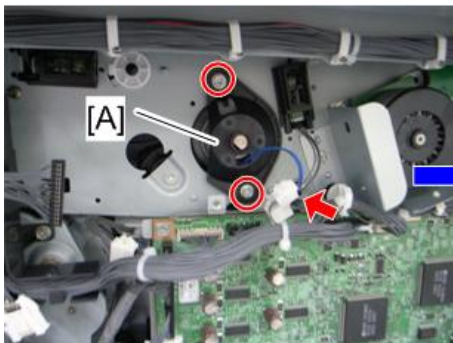

m022r596

5. Development clutch: K cover [A] (⚙️ x 2, 📁 x 1)
6. Development clutch: K [B]

Fusing/Paper Exit Motor

1. Rear cover (📄 page 213)
2. Rear lower cover (📄 page 212)
3. Right rear cover (📄 page 214)

4. PSU box (📄 page 443)
5. Drive unit fan base (📄 page 303 "Gear Unit")

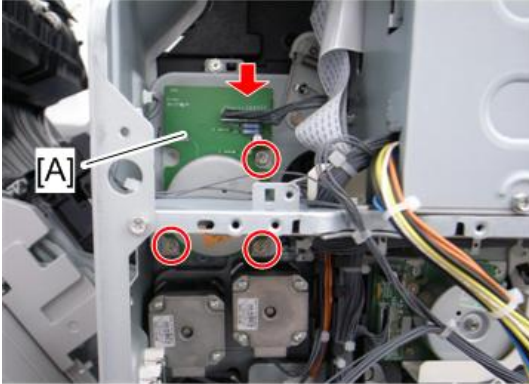

m022r784

6. Fusing/paper exit motor [A] (🔩 x 3, 📦 x 1)

Motors with Bracket

1. Rear lower cover (📄 page 212)
2. Right rear cover (📄 page 214)
3. PSU box (📄 page 443)

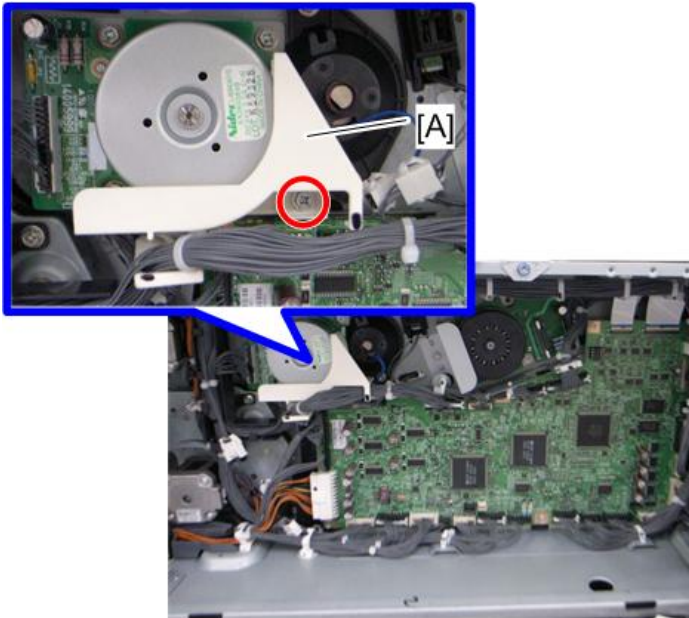

m022r597

4. Harness guide: white [A] (🔧 x 1)
5. Remove all the connectors and clamps.

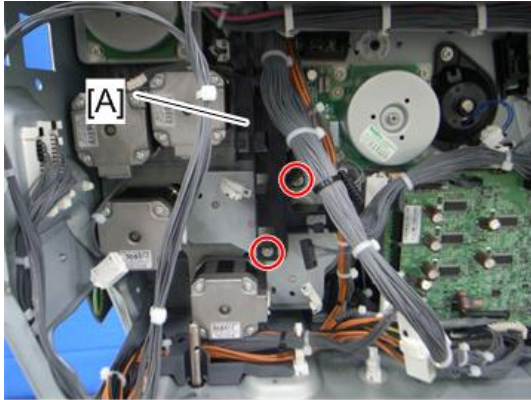

m022r598

6. Harness guide: black [A] (🔧 x 2)

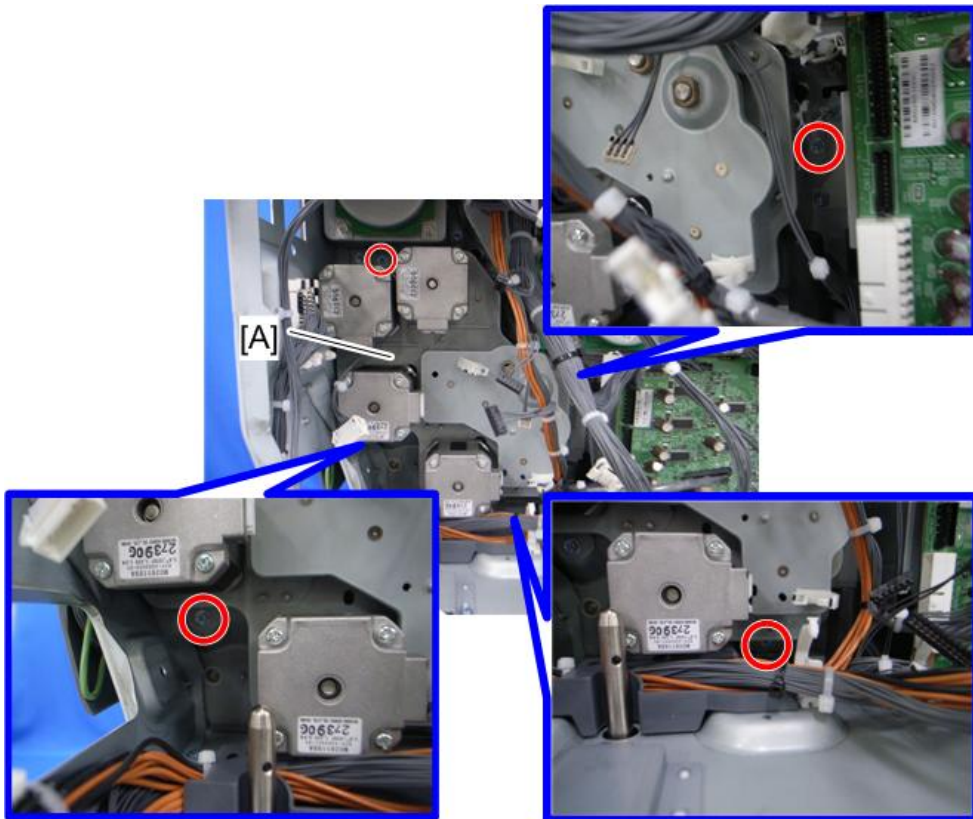

m022r599

7. Motors with bracket [A] (🔧 x 4)

Registration Motor

1. Rear lower cover (🔧 page 212)
2. PSU box (🔧 page 443)
3. Motors with bracket (🔧 page 312)

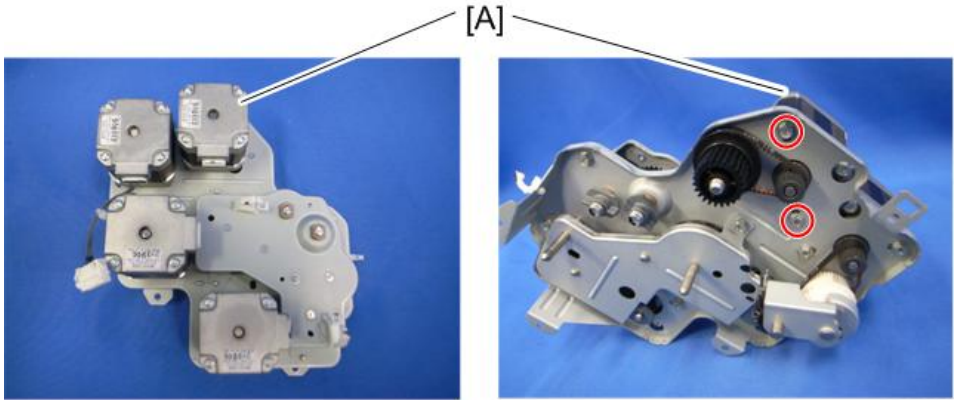

4. Registration motor [A] (🔧 x 2, timing belt x 1)

Duplex/ By-pass Motor

1. Rear lower cover (🔧 page 212)
2. PSU box (🔧 page 443)
3. Motors with bracket (🔧 page 312)

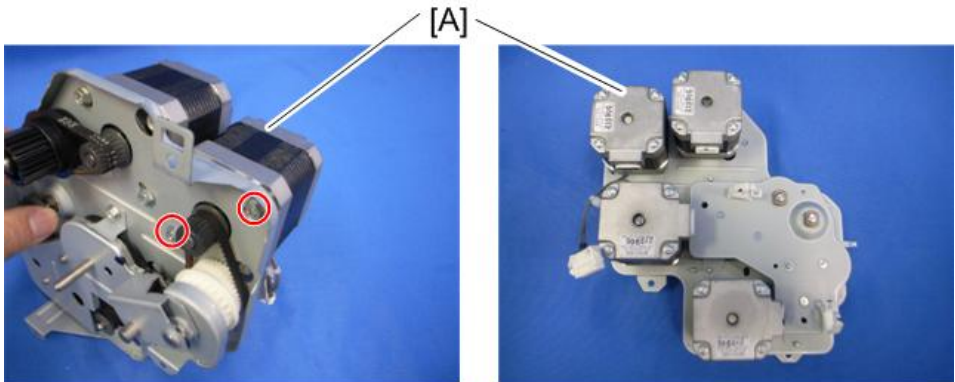

4. Duplex/ By-pass motor [A] (🔧 x 2, timing belt x 1)

Paper Feed Motor

1. Rear lower cover (🔧 page 212)
2. PSU box (🔧 page 443)
3. Motors with bracket (🔧 page 312)

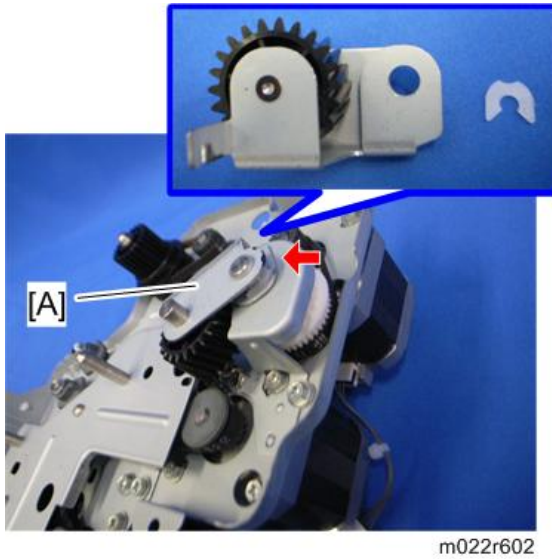

4. Gear with bracket [A] (🔧 x 1)

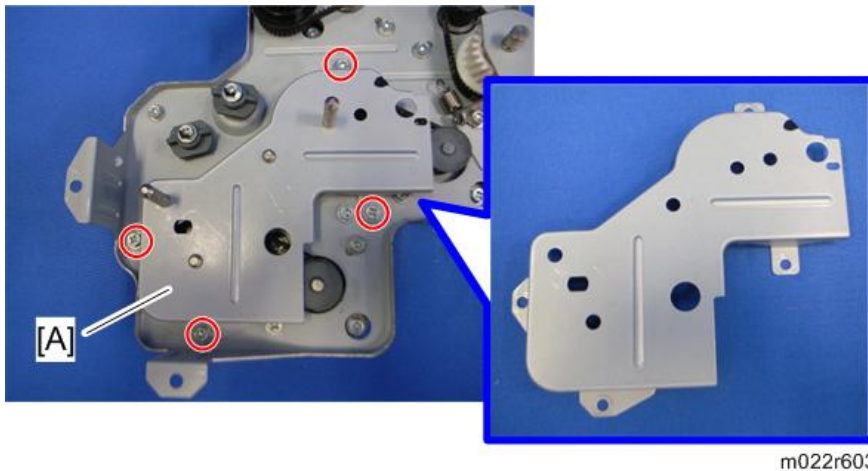

5. Bracket [A] (🔧 x 4)

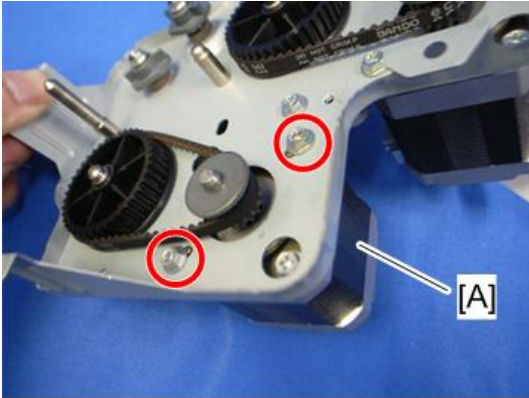

m022r604

4

6. Paper feed motor [A] (⌘ x 2, timing belt x 1)

Vertical Transport Motor

1. Rear lower cover (⌘ page 212)
2. PSU box (⌘ page 443)
3. Motors with bracket (⌘ page 312)

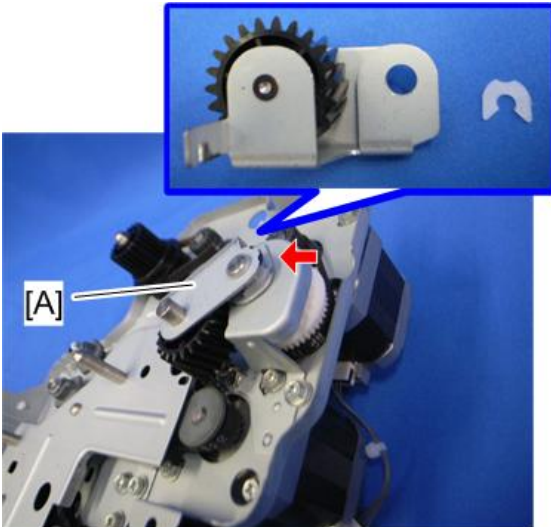

m022r602

4. Gear with bracket [A] (⌘ x 1)

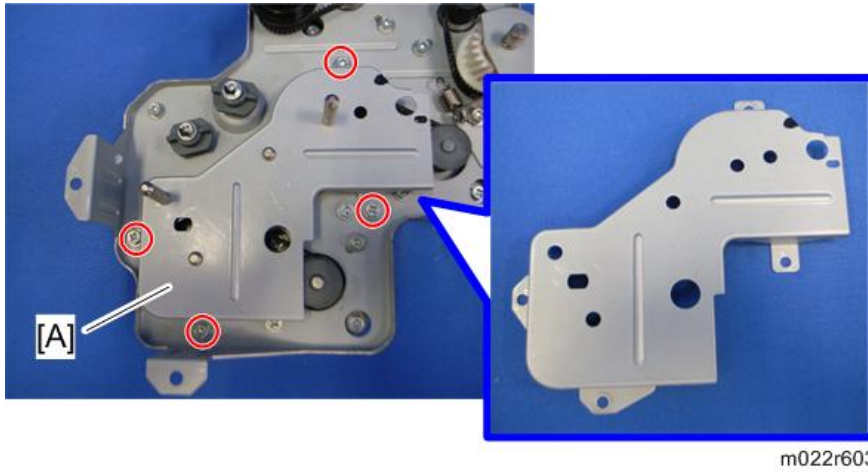

5. Bracket [A] (⌀ x 4)

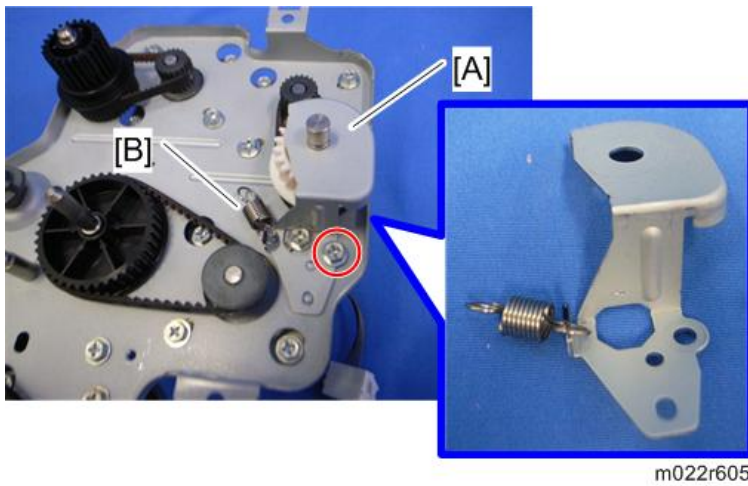

6. Remove the bracket [A] and the spring [B].

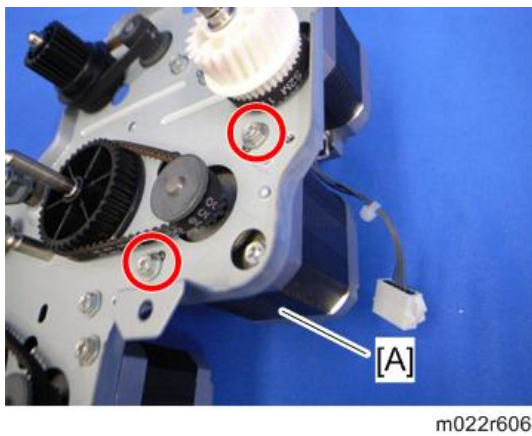

- 7. Vertical transport motor [A] (🔩 x 2)

Drum Phase Sensor: CMY

- 1. Rear cover (🔩 page 213)
- 2. Rear lower cover (🔩 page 212)
- 3. Right rear cover (🔩 page 214)
- 4. Controller box (🔩 page 423)
- 5. Fusing rear fan base (🔩 page 303 "Gear Unit")
- 6. Drive unit fan base (🔩 page 303 "Gear Unit")
- 7. PSU box (🔩 page 443)
- 8. Stay (🔩 page 303)

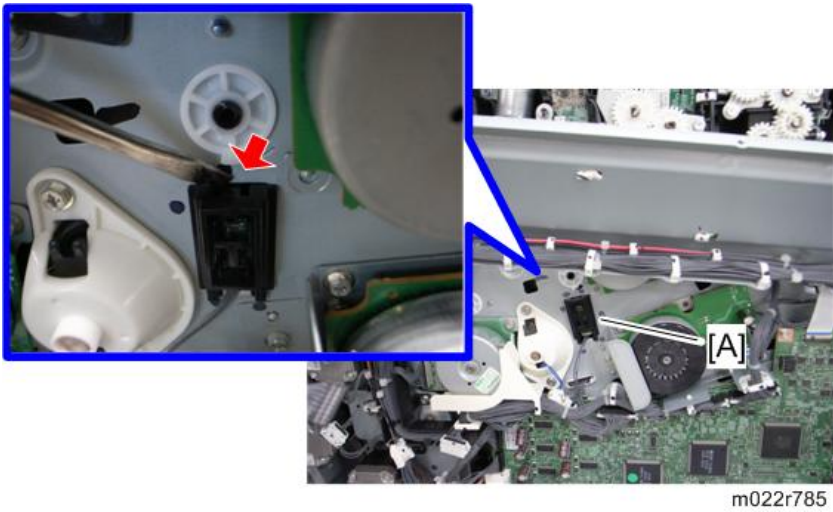

- 9. Push the hook, and then release the sensor holder [A].

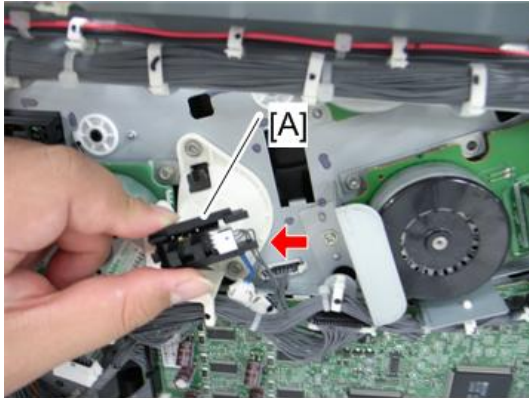

m022r786

10. Drum phase sensor: CMY [A] (☞ x 1, hooks)

4

Drum Phase Sensor: K

1. Rear cover (☞ page 213)
2. Rear lower cover (☞ page 212)
3. Right rear cover (☞ page 214)
4. Controller box (☞ page 423)
5. Fusing rear fan base (☞ page 303 "Gear Unit")
6. Drive unit fan base (☞ page 303 "Gear Unit")
7. PSU box (☞ page 443)
8. Stay (☞ page 303 "Gear Unit")

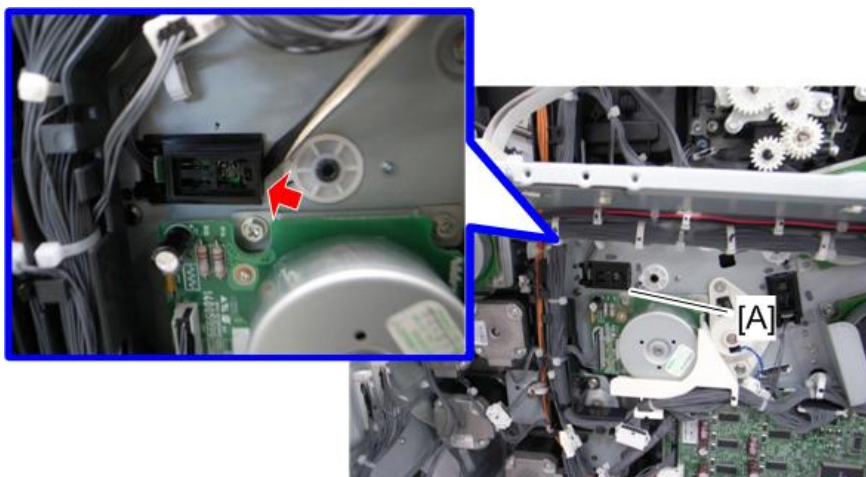

m022r787

9. Push the hook, and then release the sensor holder [A].

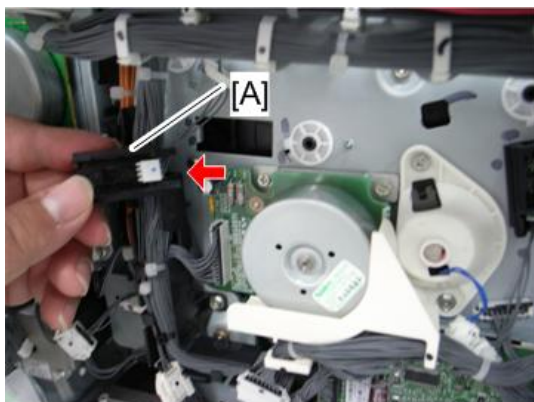

m022r788

4

10. Drum phase sensor: K [A] (🔌 x 1, hooks)

Inverter Motor

1. Rear cover (🔧 page 213)

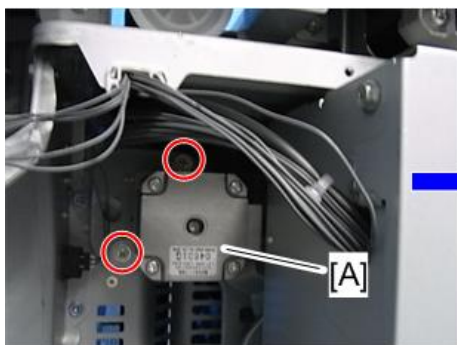

m022r861

2. Inverter motor base [A] (🔧 x 2, 📐 x 1)

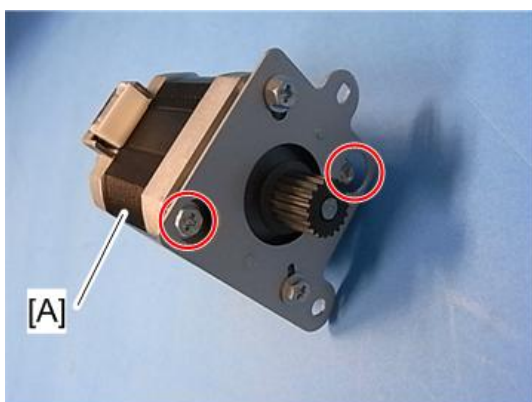

m022r862

- Inverter motor [A] (🔩 x 2)

Drive Unit Fan

- Rear cover (🔩 page 213)

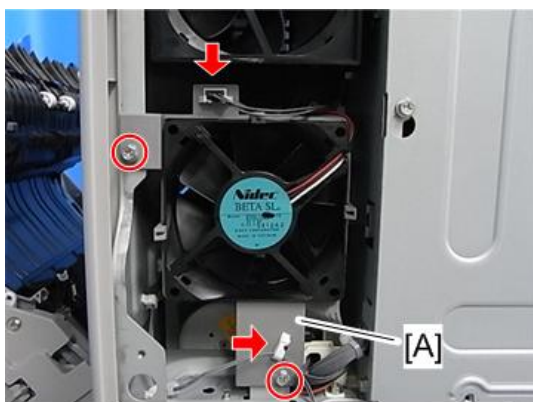

m022r859

- Drive unit fan base [A] (🔩 x 2, 📏 x 1, 📏 x 1)

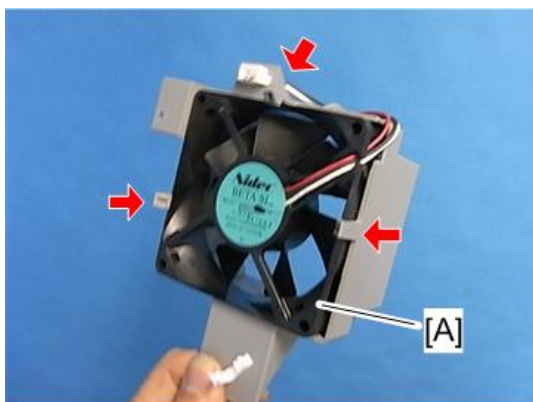

m022r860

- Drive unit fan [A] (📏 x 1, hooks)



When installing the drive unit fan

Make sure that the drive unit fan is installed with its decal facing the rear of the machine.

Fusing

Fusing Unit Maintenance Parts

In the fusing unit, there are some maintenance parts. However, these parts are defined as yield parts. Refer to the following list to check the maintenance parts.

Maintenance Parts	Replacement Procedure
Pressure Roller-Bearing	 page 329 "Pressure Roller"
Fusing Roller-Bearing	 page 336 "Fusing Belt"

4

Fusing Unit

If you replace a fusing unit, then you must reset the PM counter for this unit. To do this, set SP 3902 014 to 1 before you start to work on the machine.

CAUTION

- Turn off the main switch and wait until the fusing unit cools down before beginning any of the procedures in this section. The fusing unit can cause serious burns.

1. Open the duplex unit.

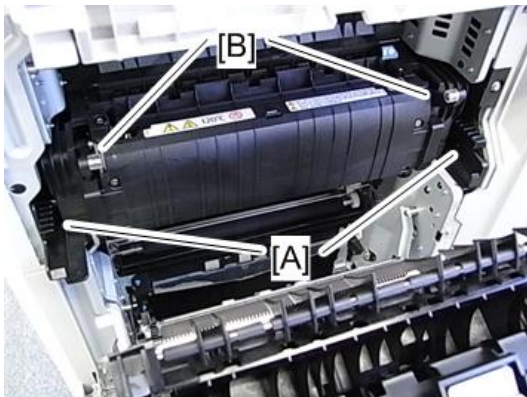

m022r878

2. Release the lock levers [A].
3. Pull out the pressure levers [B] a short distance.

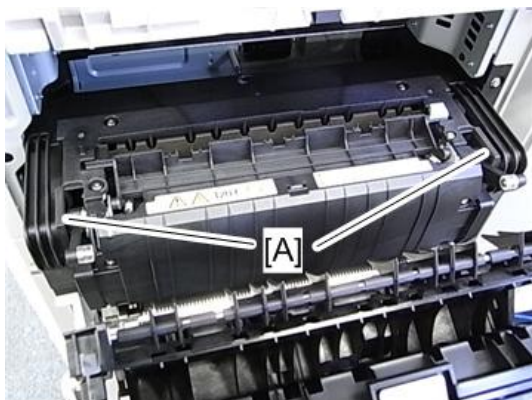

m022r879

4. Hold the fusing unit handles [A], and then pull out the fusing unit.

4

When installing the fusing unit

Make sure that the both lock levers are locked before closing the duplex unit. Otherwise, these lock levers can be broken.

Cleaning Unit

1. Fusing unit (see page 322)

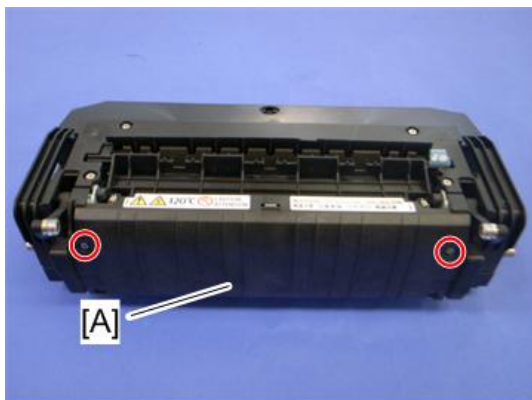

m065r667

2. Fusing front cover [A] (x 2)

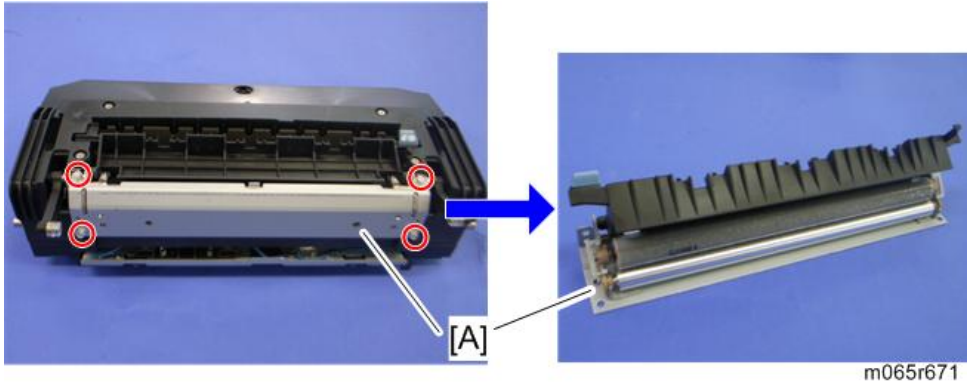

3. Cleaning unit [A] (⌀ x 4)

4

Oil Supply Roller

1. Cleaning unit (see page 323)

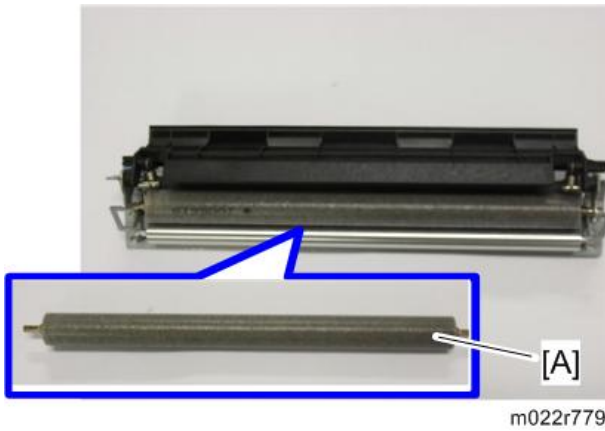

2. Oil supply roller [A]

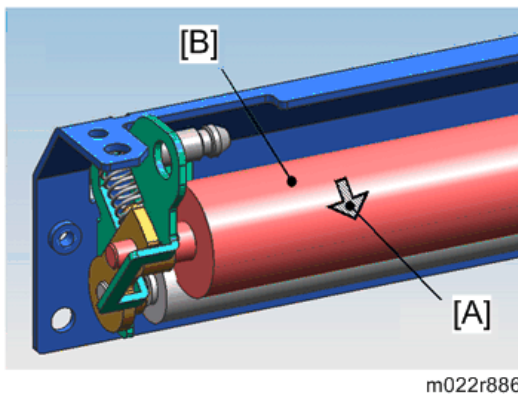

Note

- Check the arrow [A] and install the oil supply roller [B] the correct way around. If not correct, the film on the oil supply roller will come off.

Cleaning Roller

1. Cleaning unit (🔗 page 323)

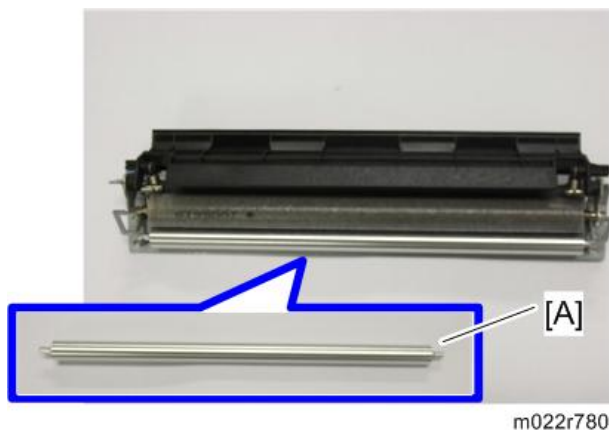

2. Cleaning roller [A]

Plain Shaft Bearing

1. Cleaning unit (🔗 page 323)

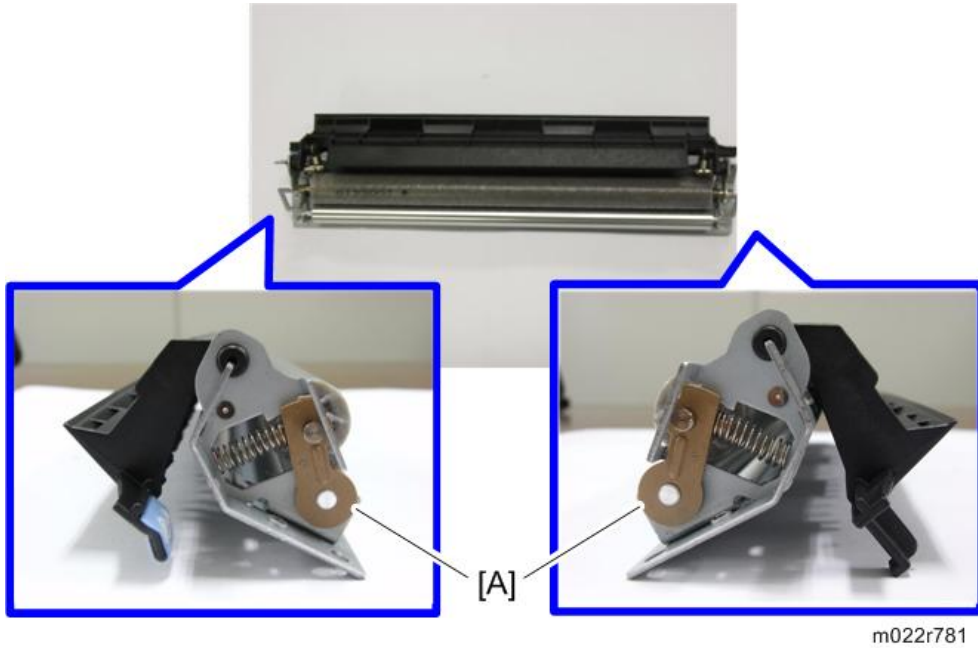

- 2. Plain shaft bearing [A]

Pressure Roller Fusing Lamp

- 1. Fusing front cover (see page 323 "Cleaning Unit")

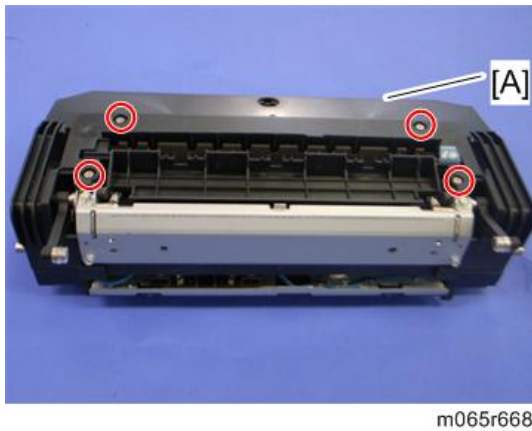

- 2. Fusing upper cover [A] (🔩 x 4)

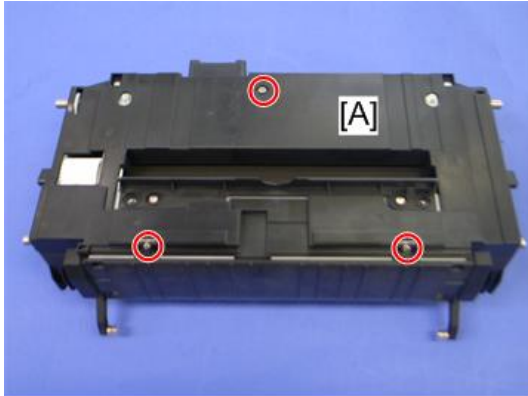

m065r665

3. Fusing lower cover [A] (🔩 x 3)
4. Cleaning unit (🧼 page 323)

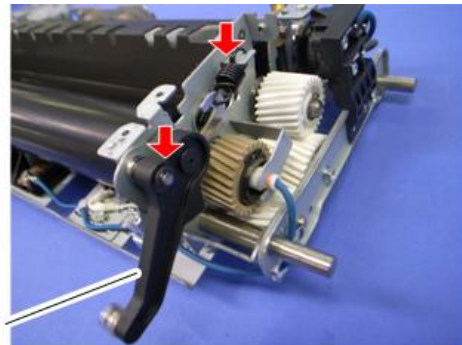
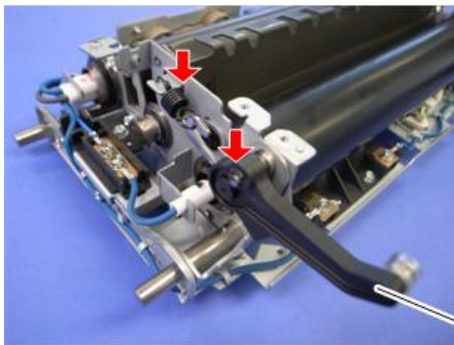

m065r674

5. Pressure levers [A] (🔩 x 1 each, spring x 1 each)

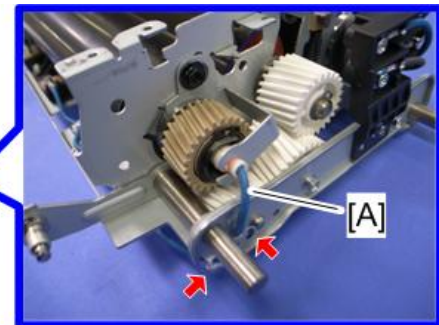
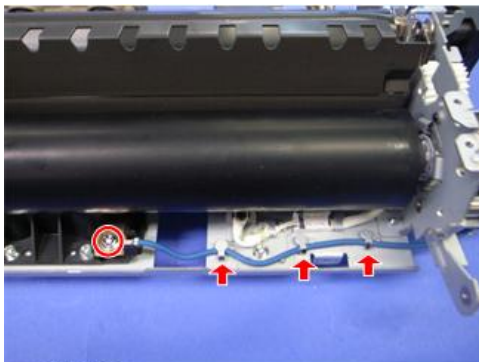

m065r675

6. Release the fusing lamp harness [A] at the right side (🔩 x 1, 🧰 x 5).

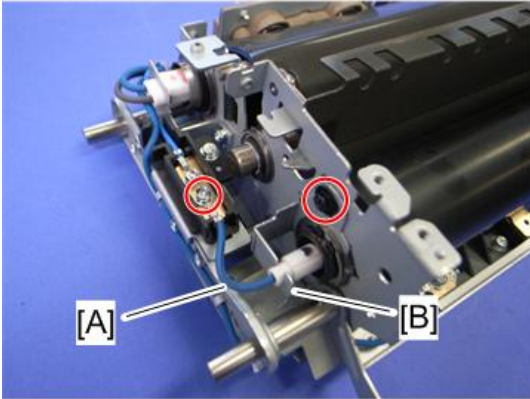

m065r677

4

- 7. Release the fusing lamp harness [A] at the left side (🔧 x 1).
- 8. Lamp holder [B] (🔧 x 1)

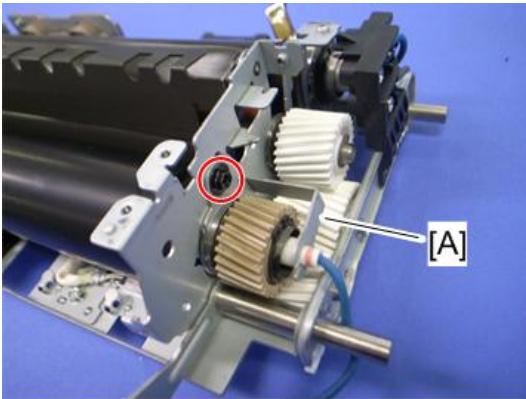

m065r676

- 9. Remove the fusing lamp holder [A] at the right side (🔧 x 1).

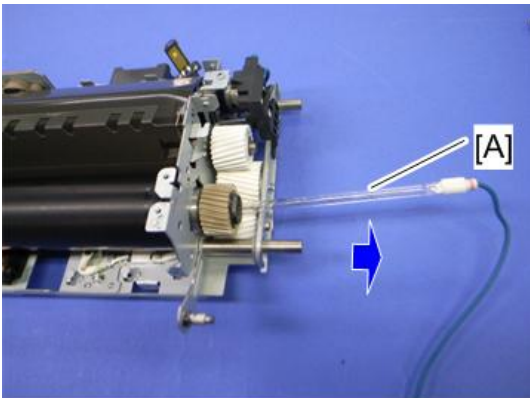

m065r678

- 10. Pressure roller fusing lamp [A]

Pressure Roller

1. Pressure roller fusing lamp (☞ page 326)

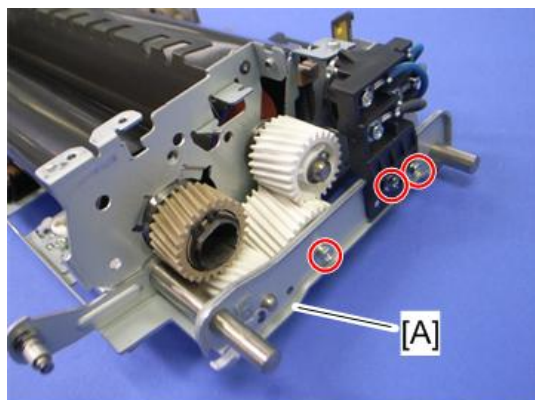

m065r747

2. Right stay [A] (☞ x 3)

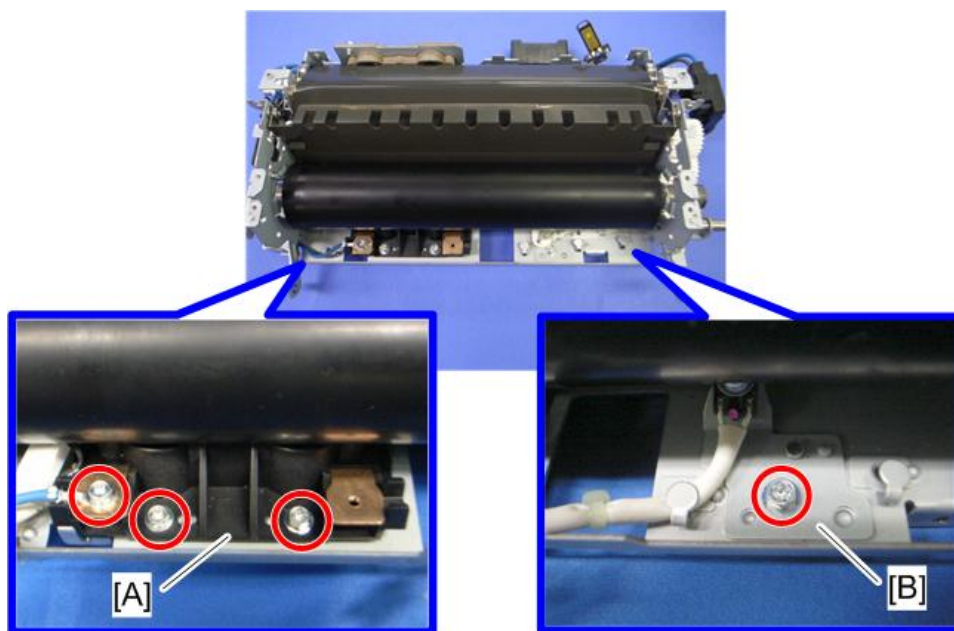

m065r820

3. Thermostat holder [A] and thermistor bracket [B] (☞ x 4)

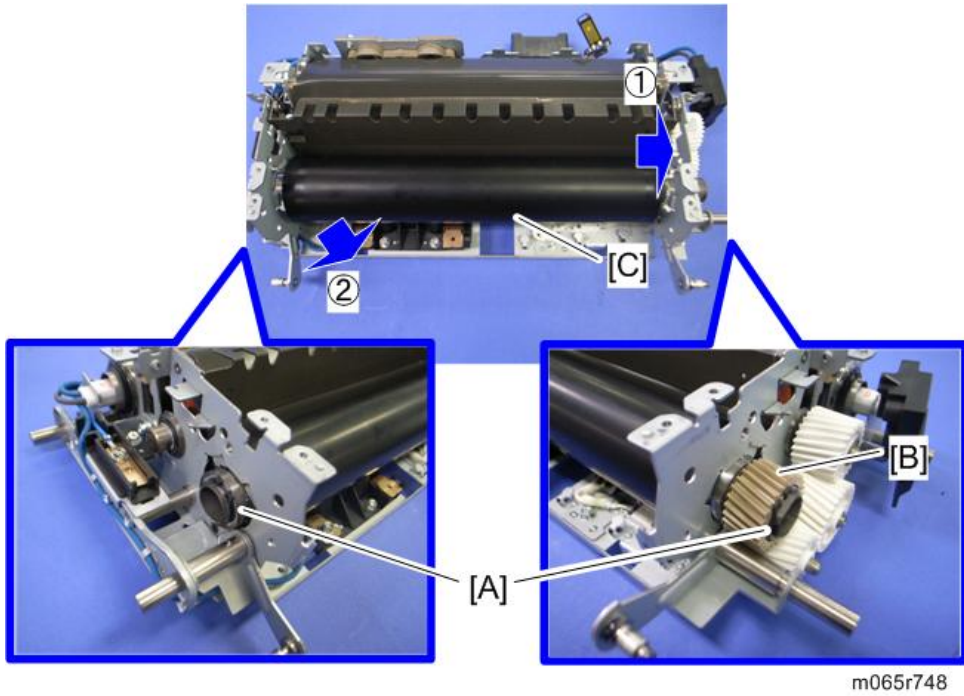

- 4. Remove the C-rings, bearings [A], and gear [B].
- 5. Pressure roller [C]

When Reinstalling the Pressure Roller

When replacing the pressure roller, you have to apply lubricant to the following places.

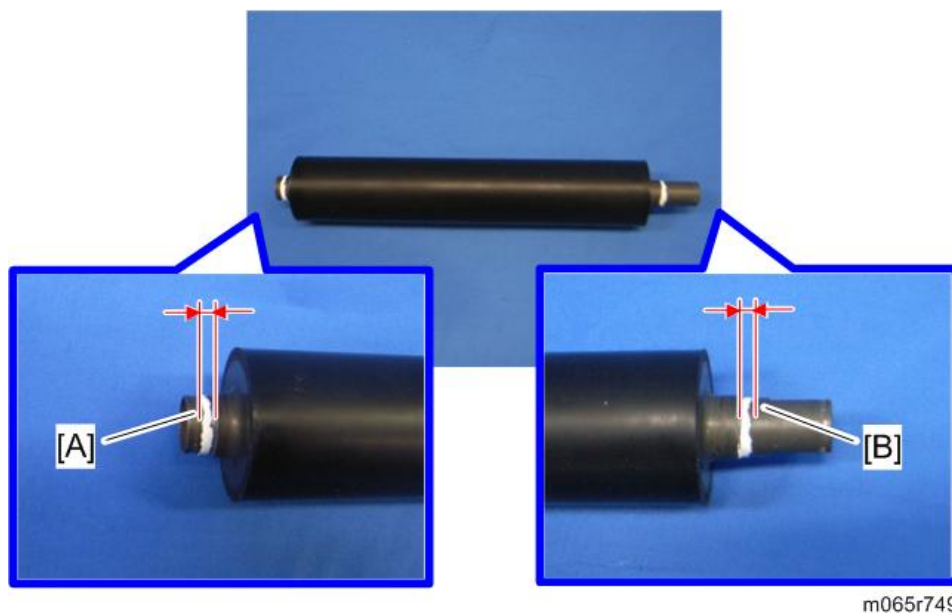

- Apply "Barrierta S552R" (0.15g to 0.25g) to the left end [A] and right end [B] of the pressure roller as shown above.

Heating Roller Fusing Lamp

1. Fusing unit (📄 page 322)
2. Fusing lower cover (📄 page 326)
3. Cleaning unit (📄 page 323)
4. Fusing upper cover (📄 page 326 "Pressure Roller Fusing Lamp")

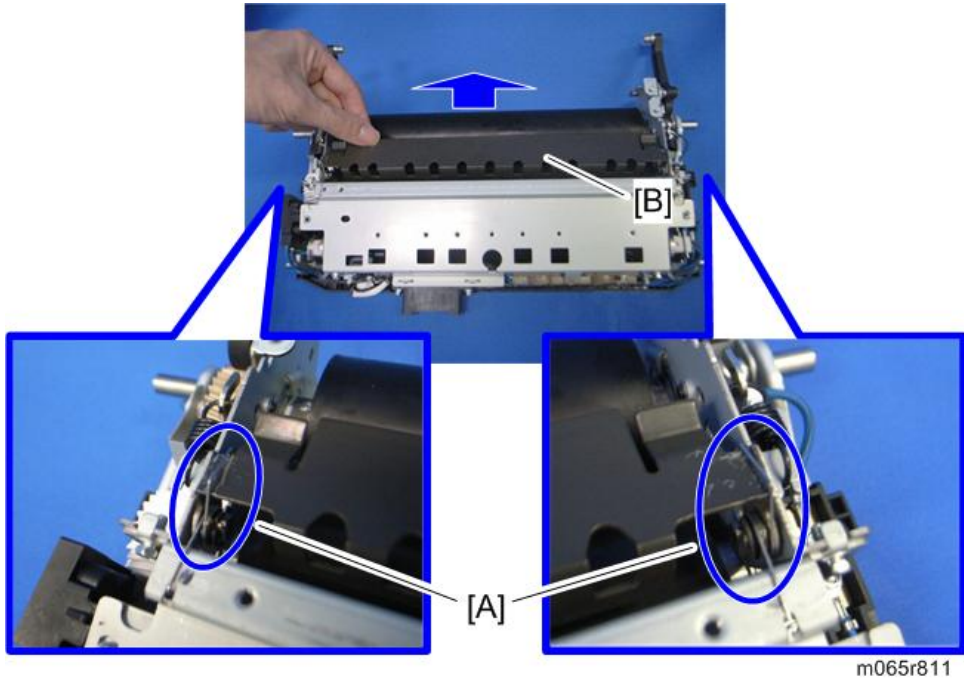

m065r811

5. Release the pins [A], and then remove the stripper plate [B].

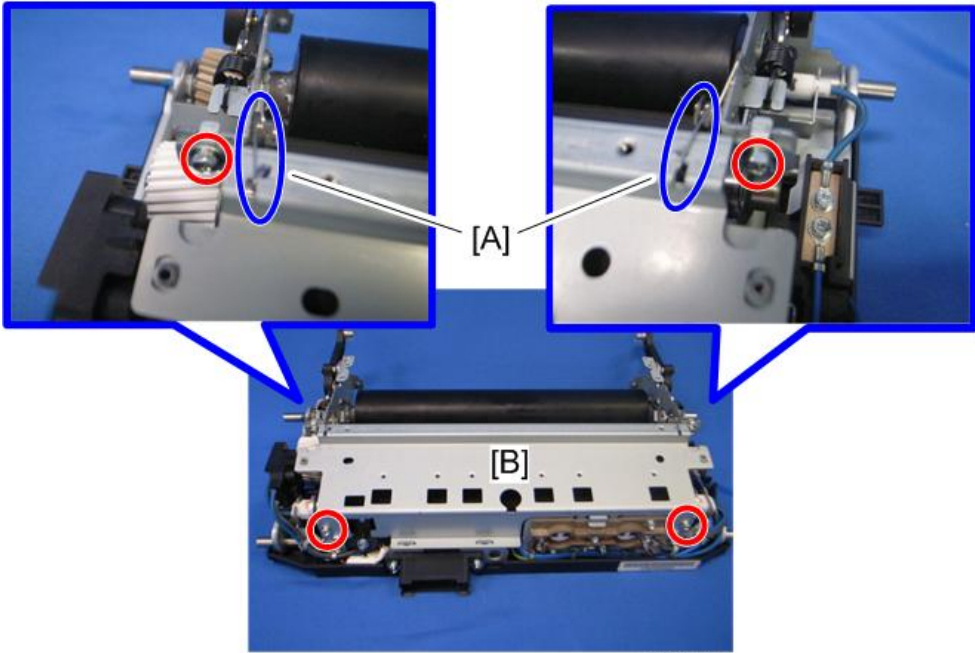

m065r812

6. Release the pins [A], and then remove the bracket [B] (⚙ x 4).

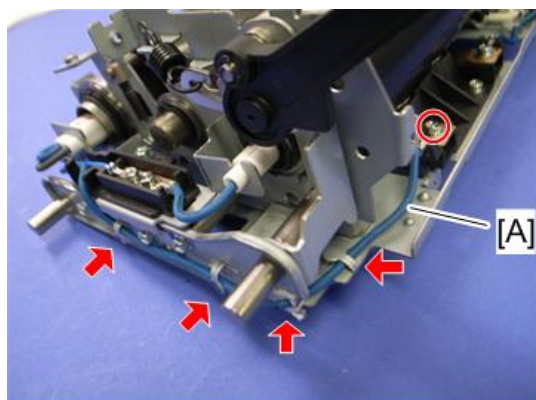

m065r681

7. Release the fusing lamp harness [A] at the left side (🔩 x 1, 🛠️ x 4).

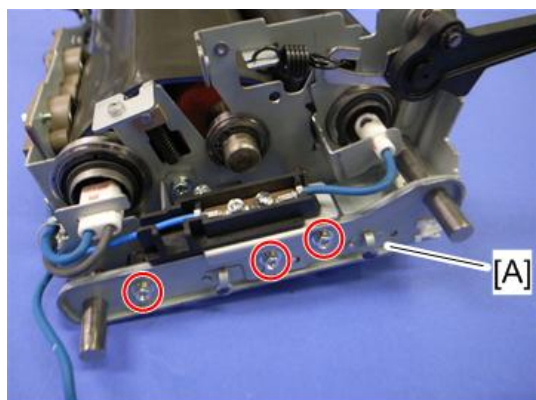

m065r682

8. Left stay [A] (🔩 x 3)

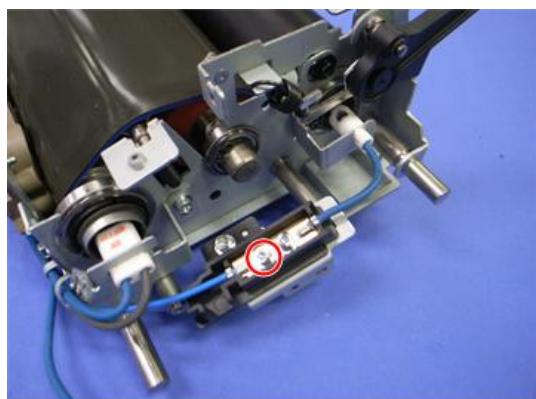

m065r683

9. Remove the screw.

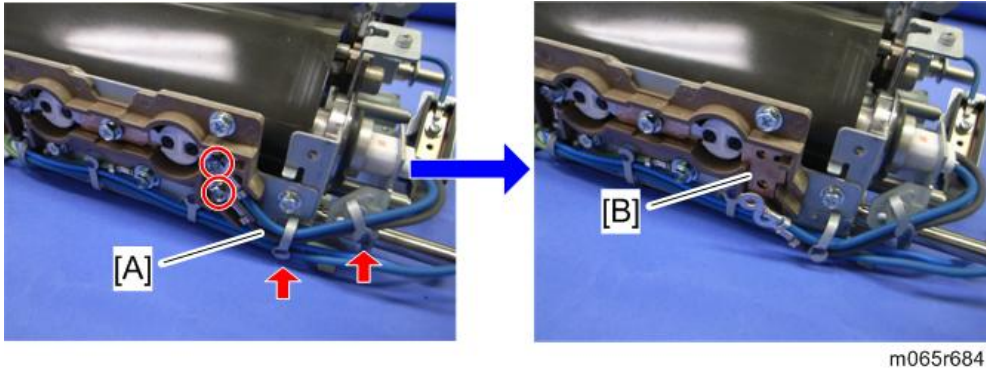

10. Release the fusing lamp harnesses [A], and then remove the plate [B] (⚙️ x 2, 🛠️ x 2).

4

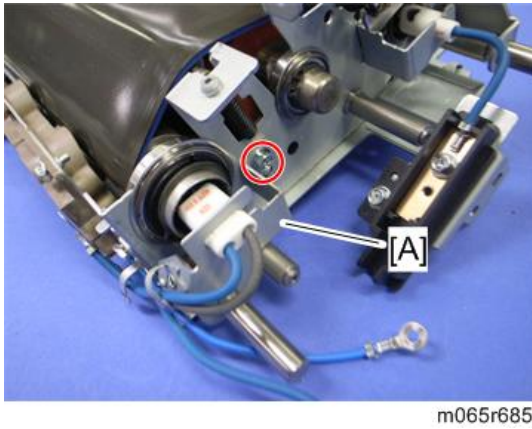

11. Remove the fusing lamp holder [A] (⚙️ x 1).

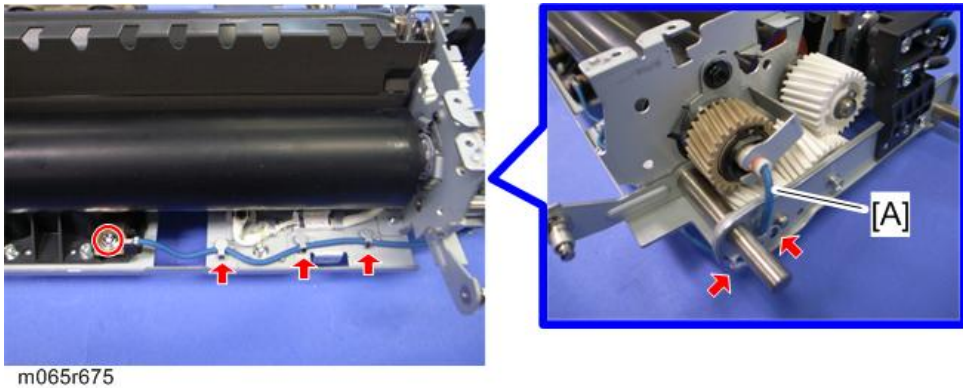

12. Release the fusing lamp harness [A] at the right side (⚙️ x 1, 🛠️ x 5).

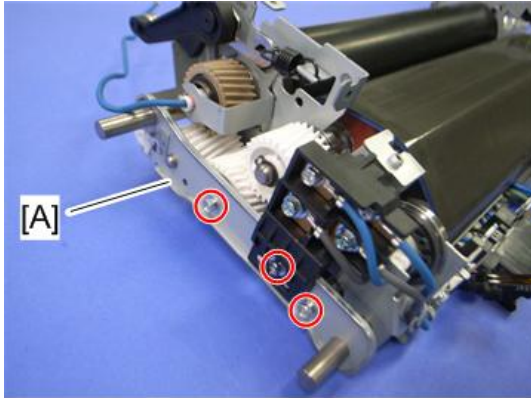

m065r686

13. Right stay [A] (🔩 x 3)

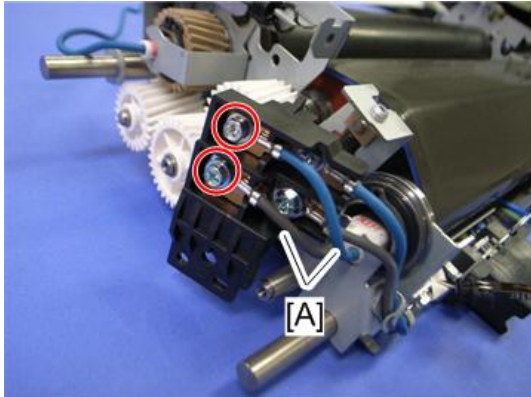

m065r687

14. Release the fusing lamp harnesses [A] (🔩 x 2).

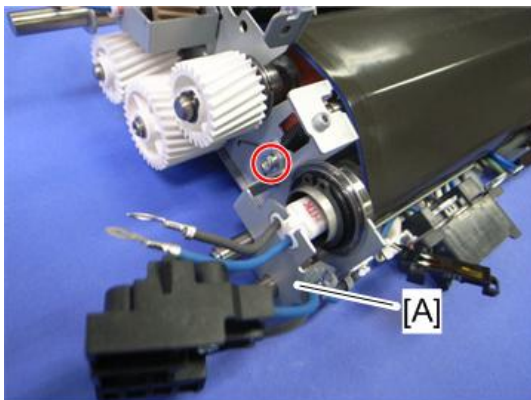

m065r688

15. Lamp holder [A] (🔩 x 1)

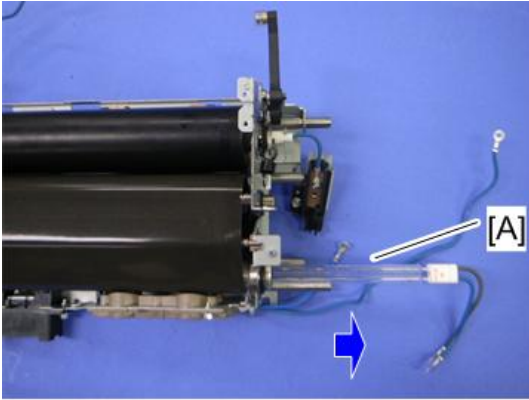

m065r689

4

16. Heating roller fusing lamp [A]

Fusing Belt

If you replace a fusing belt, then you must reset the PM counter for this unit. To do this, set SP 3902 016 to 1 before you start to work on the machine.

1. Heating roller fusing lamp (☞ page 331)

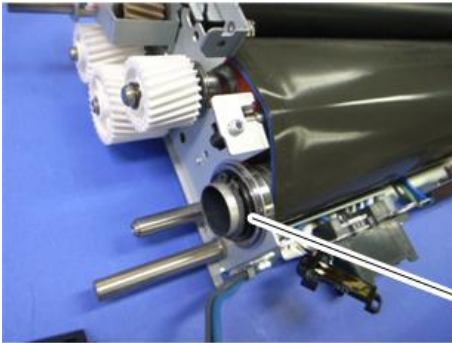

m065r750

2. C-rings and bearings [A]

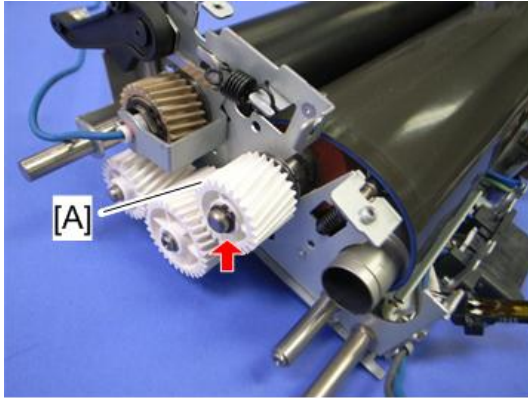

m065r751

3. Gear [A] at the left side (C-ring x 1)

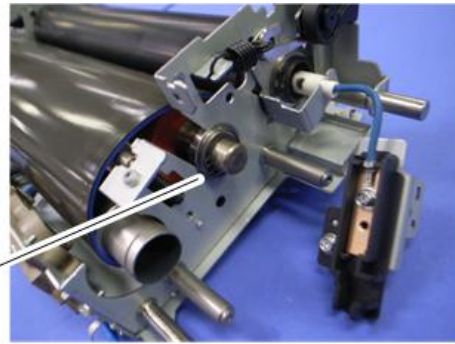
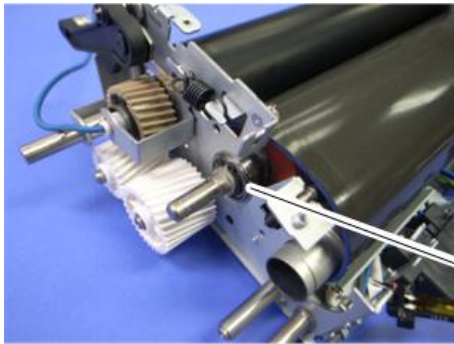

m065r752

4. C-rings and bearings [A]

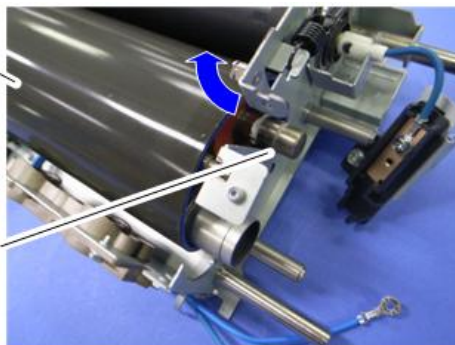
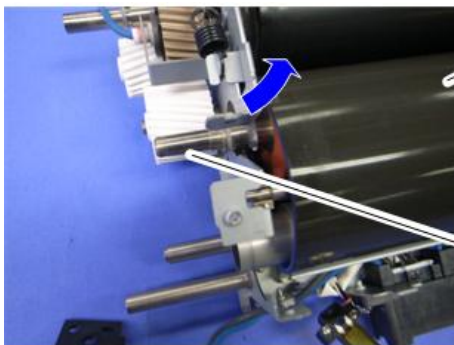

m065r753

5. Remove the fusing belt [A] with rollers, lifting the shafts [B] up.

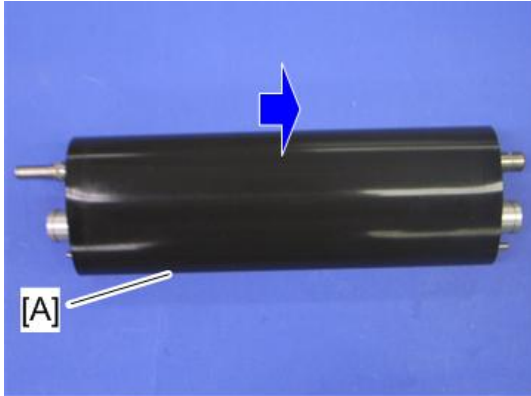

m065r754

4

6. Fusing belt [A]

Fusing, Heating and Tension Roller

If you replace a fusing roller, then you must reset the PM counter for this unit. To do this, set SP 3902 015 to 1 before you start to work on the machine.

1. Fusing belt with rollers (see page 336)

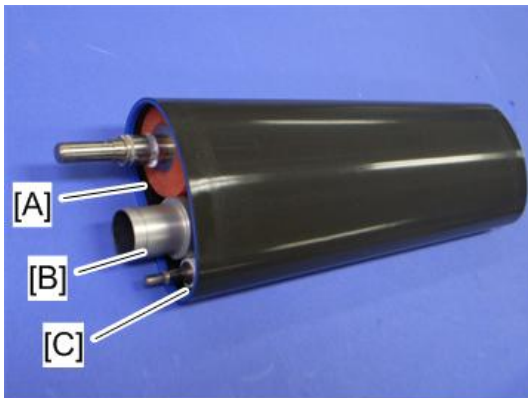

m065r756

2. Fusing roller [A], heating roller [B] and tension roller [C]

When Reinstalling the Fusing Roller

When replacing the fusing roller, you have to apply lubricant to the following places.

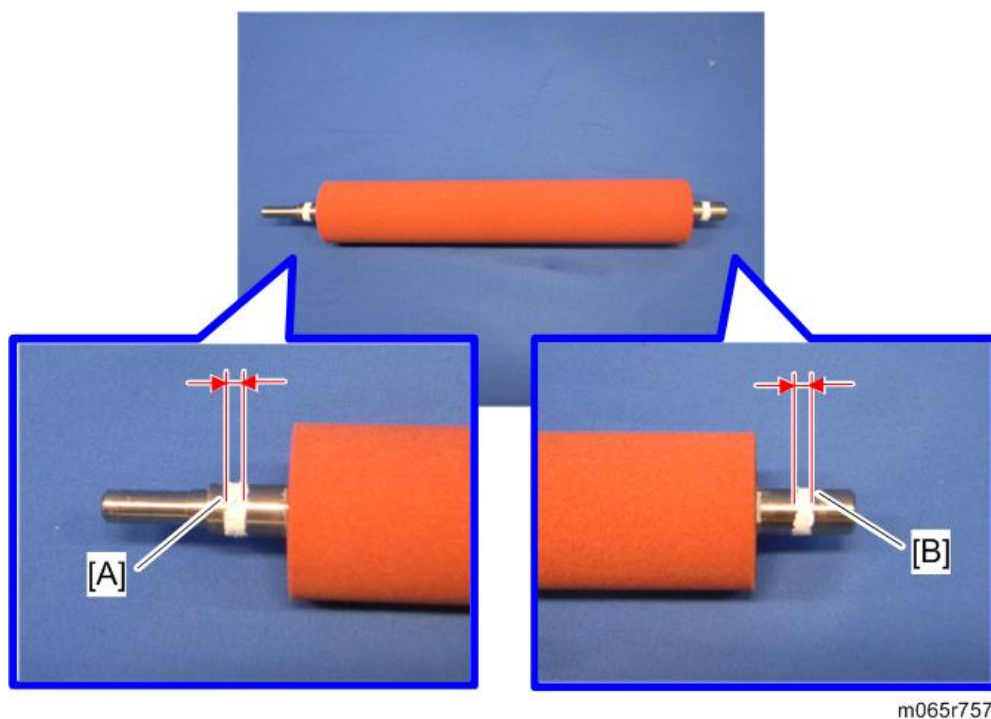

- Apply "Barrierta S552R" (0.1g to 0.2g) to the left end [A] and right end [B] of the fusing roller as shown above.

Heating Roller Thermostat

1. Fusing front cover (☛ page 323 "Cleaning Unit")
2. Fusing upper cover (☛ page 326 "Pressure Roller Fusing Lamp")

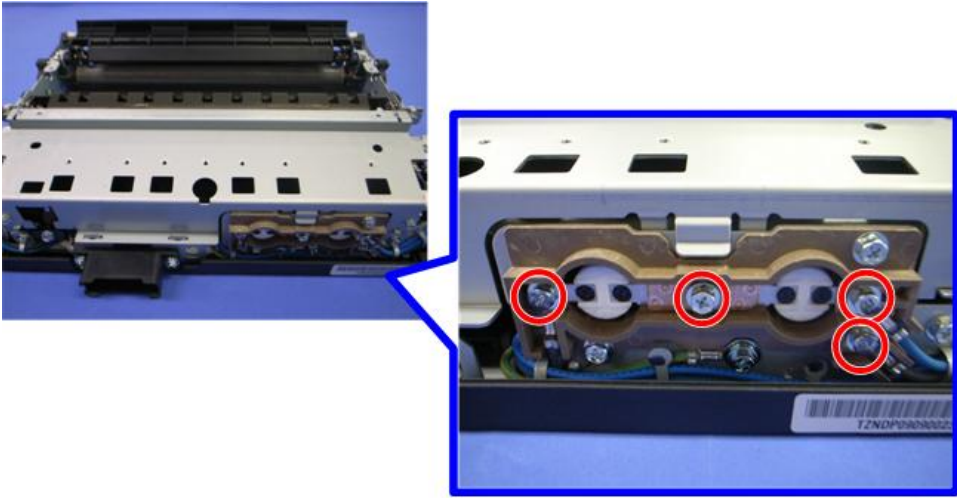

m065r669

3. Remove the four screws.

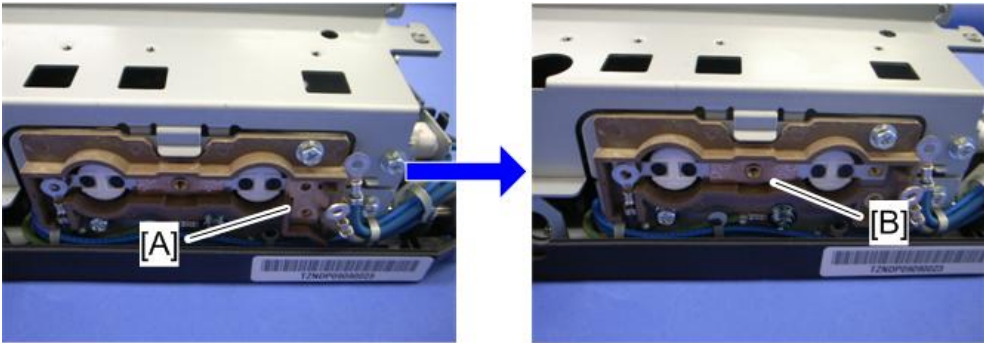

m065r670

4. Remove the plate [A], and then remove the heating roller thermostats [B].

⚠ CAUTION

- Do not re-use a thermostat that is already opened. Safety is not guaranteed if you do this.

Heating Roller Thermistor

1. Fusing front cover (📄 page 323 "Cleaning Unit")
2. Fusing upper cover (📄 page 326 "Pressure Roller Fusing Lamp")
3. Fusing lower cover (📄 page 326 "Pressure Roller Fusing Lamp")

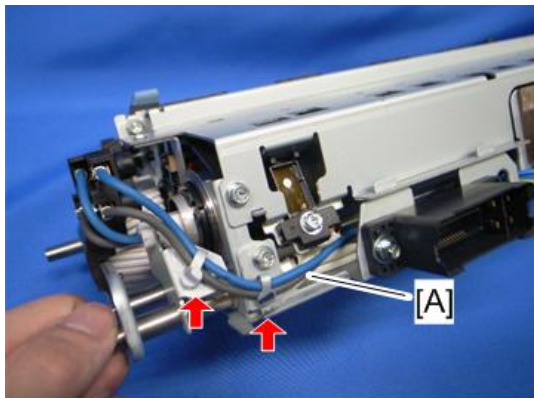

m065r803

4. Release the harness [A] (🔧 x 2).

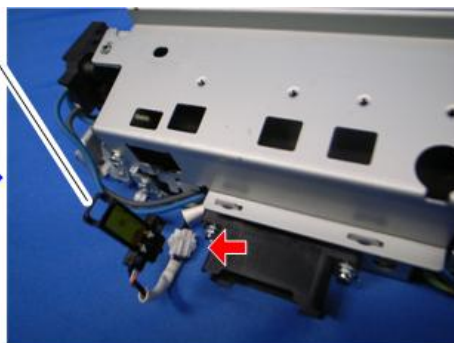
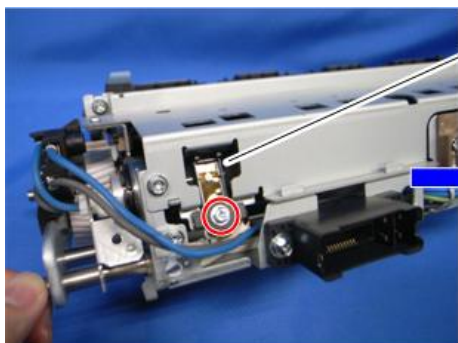

m065r804

5. Heating roller thermistor [A] (🔧 x 1, 📏 x 1)

Pressure Roller Thermistor

1. Cleaning unit (📄 page 323 "Cleaning Unit")

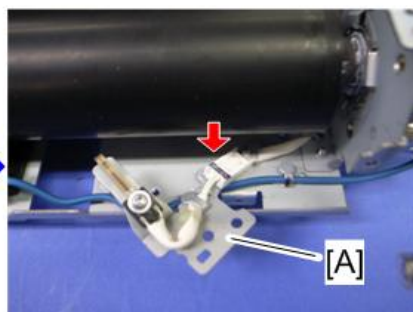
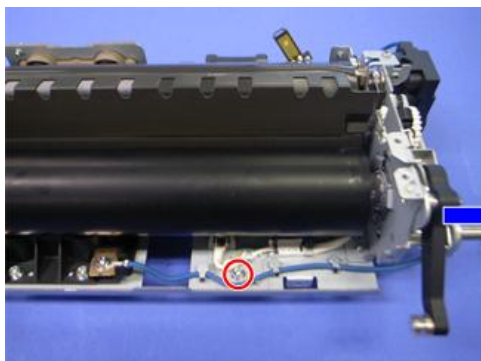

m065r672

2. Thermistor assembly [A] (🔧 x 1, 📏 x 1)

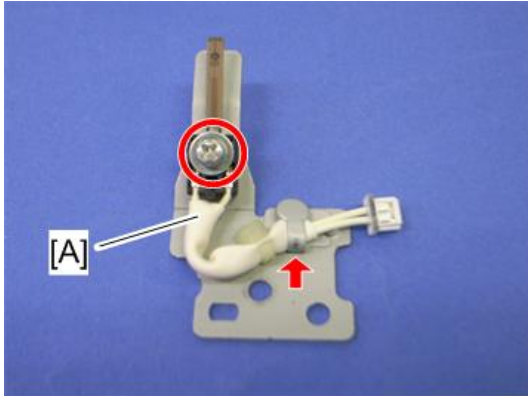

m065r673

4

3. Pressure roller thermistor [A] (🔩 x 1, 📡 x 1)

Pressure Roller Thermostat

1. Fusing lower cover (📖 page 326 "Pressure Roller Fusing Lamp")

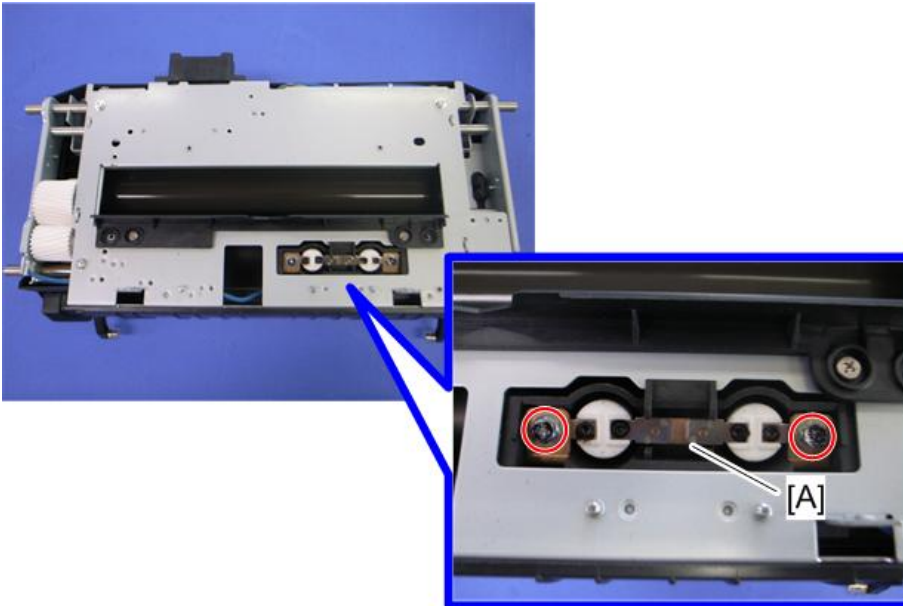

m065r666

2. Pressure roller thermostats [A] (🔩 x 2)

Thermopile

1. Paper exit unit (📖 page 358)

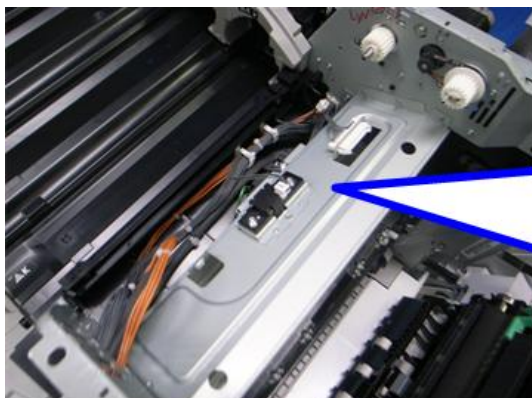

m065r549

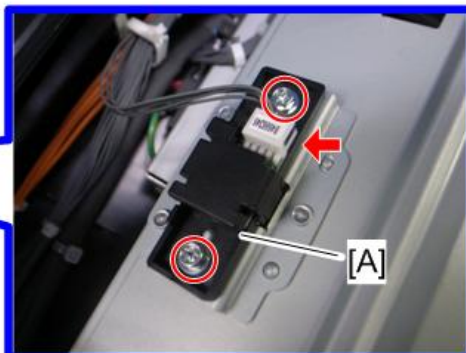

2. Thermopile base [A] (🔧 x 2, 📦 x 1)

4

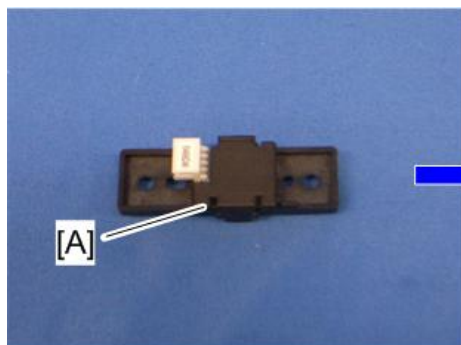

3. Thermopile cover [A] (hooks)

4. Thermopile [B]

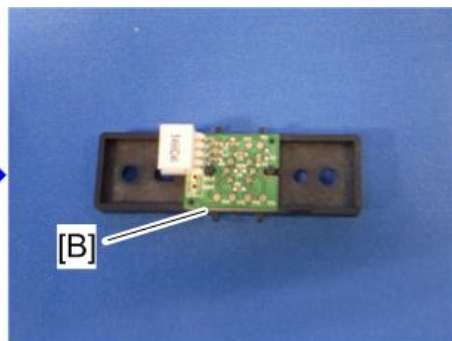

m065r550

Fusing Front Fan

1. Inner right cover (📄 page 226)

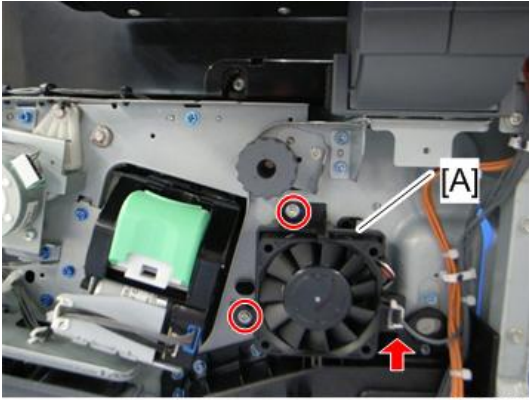

m022r835

4

2. Fusing front fan base [A] (🔩 x 2, 📏 x 1)

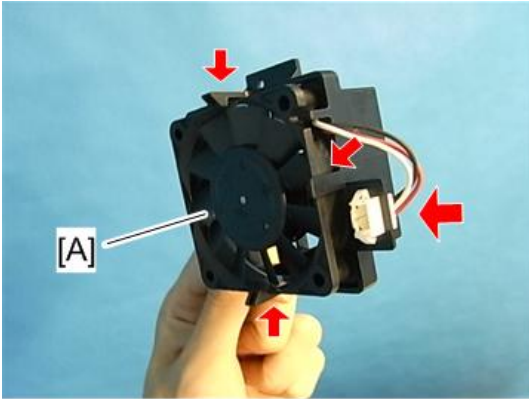

m022r836

3. Fusing front fan [A] (📏 x 1, hooks)

When installing the fusing front fan

Make sure that the fusing front fan is installed with its decal facing the rear of the machine.

Fusing Rear Fan

1. Rear cover (📄 page 213)

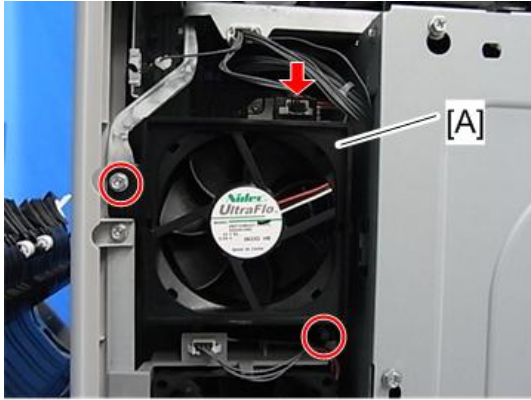

m022r856

2. Fusing rear fan base [A] (🔩 x 2, 📁 x 1)

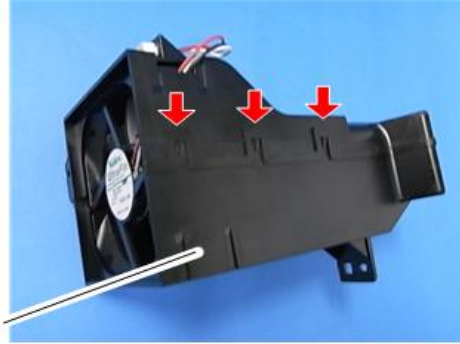
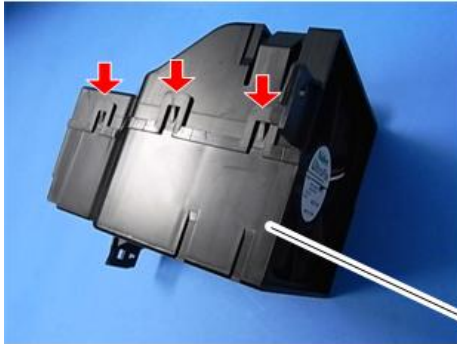

m022r857

3. Fusing rear fan cover [A] (hooks)

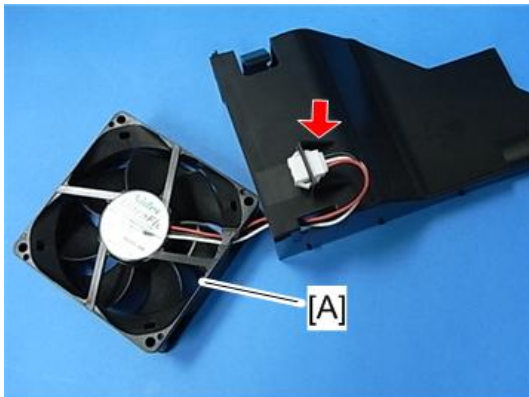

m022r858

4. Fusing rear cover [A] (📁 x 1)

When installing the fusing rear fan

Make sure that the fusing rear fan is installed with its decal facing the rear of the machine.

Paper Feed

Separation Roller

1. Pull out the paper tray.
2. Duplex unit (📄 page 366)

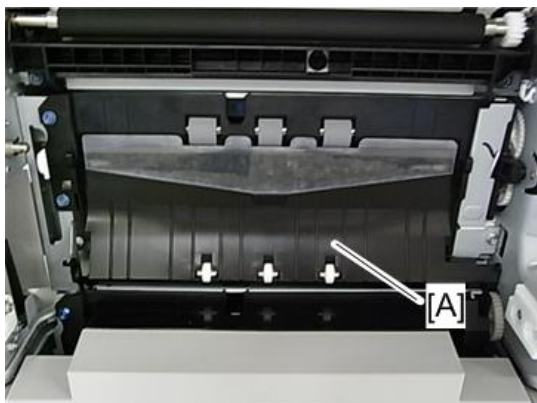

m022r654

3. Open the guide plate [A].

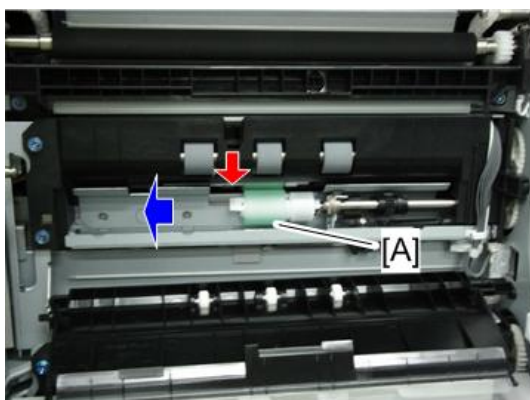

m022r655a

4. Separation roller [A] (📄 x 1).

Paper Feed Unit

1. Pull out the paper tray.
2. Duplex unit (📄 page 366)

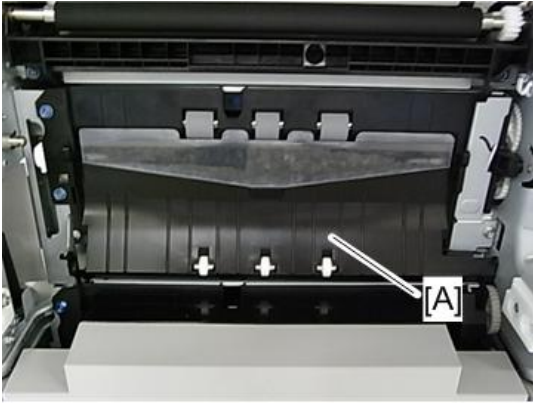

m022r654

4

3. Guide plate [A]

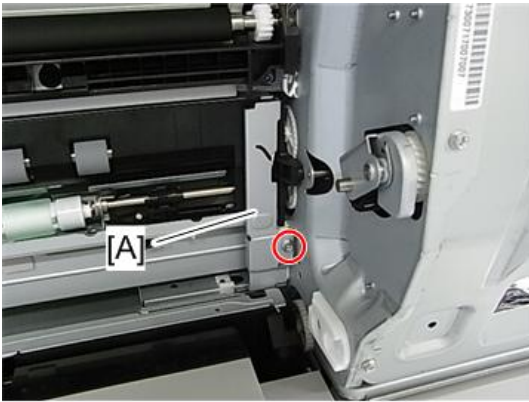

m022r894

4. Bracket [A] (⚙ x 1)

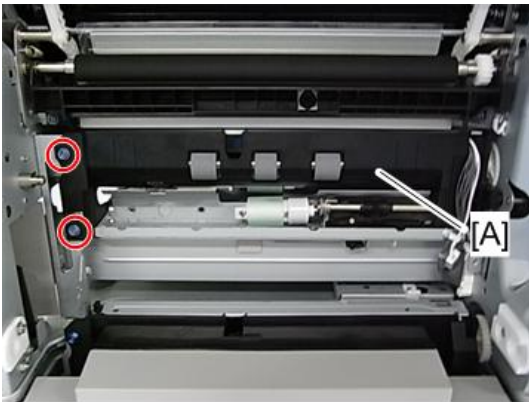

m022r655

5. Release the paper feed unit [A] (⚙ x 2).

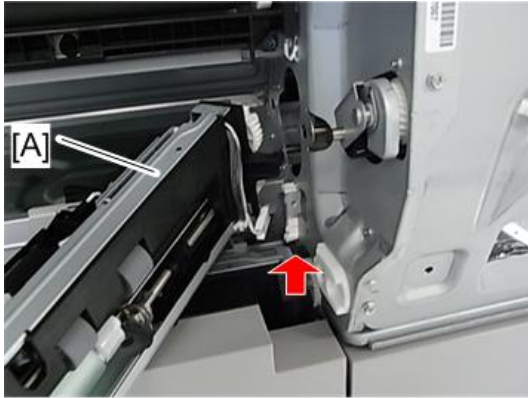

m022r651a

6. Paper feed unit [A] (📄 x 1)

4

Pick-up and Paper Feed Rollers

1. Pull out the paper tray.

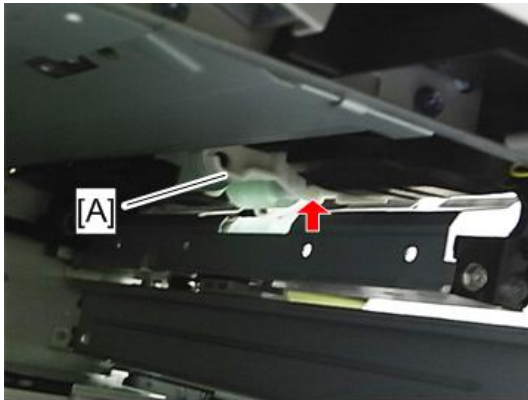

m022r614a

2. Roller holder [A] (📄 x 1)

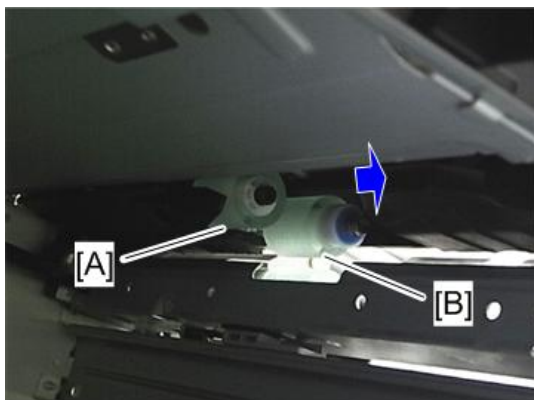

m022r615a

4

3. Pick-up roller [A]
4. Paper feed roller [B]

Registration Sensor

1. Duplex unit (see page 366)



m022r646a

2. Registration roller guide [A] (x 2)

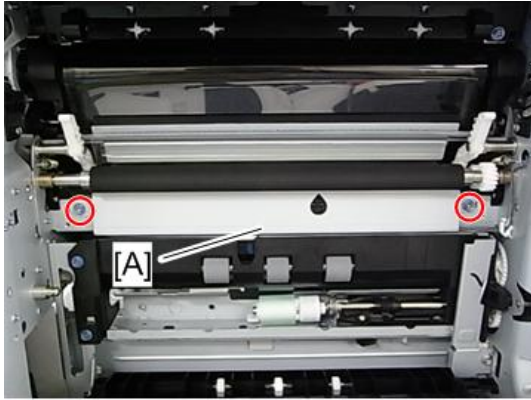

m022r647a

3. Bracket [A] (🔩 x 2)

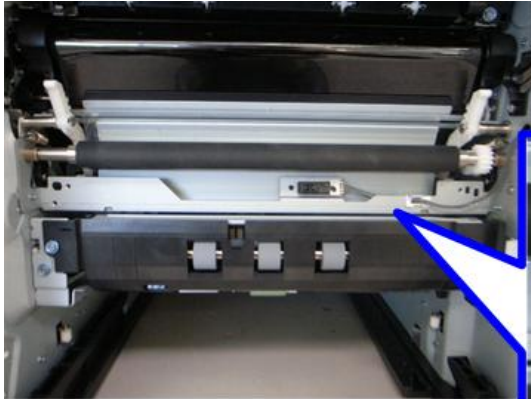

m065r648

4. Registration sensor [A] (📷 x 1, hooks)

Vertical Transport Sensor

1. Paper feed unit (📄 page 347)



m022r652a

4

2. Vertical transport sensor bracket [A] (🔩 x1, 📏 x1)

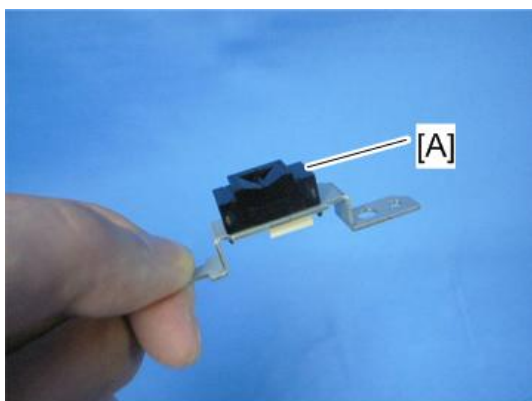

m065r653

3. Vertical transport sensor [A] (hooks)

Paper Lift Sensor

1. Paper feed unit (🔗 page 347)

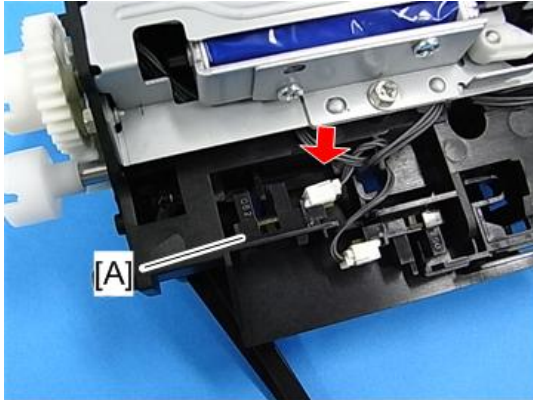

m022r659a

2. Paper lift sensor [A] (📎 x1, hooks)

4

Paper End Sensor

1. Paper feed unit (📎 page 347)

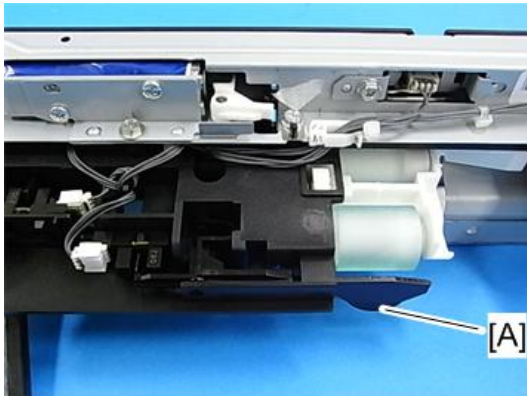

m022r660a

2. Actuator [A] (tab x 2)

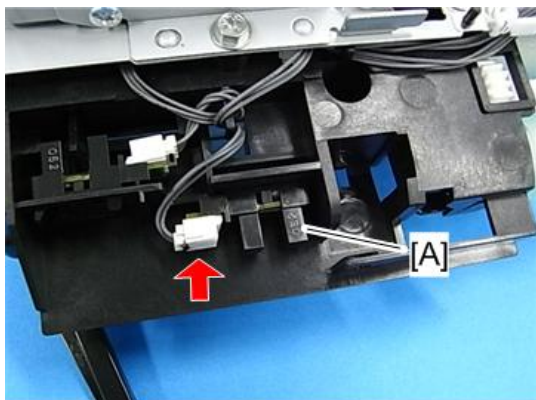

m022r661a

4

3. Paper end sensor [A] (🔌 x1, hooks)

Paper Feed Sensor

1. Paper feed unit (🔌 page 347)

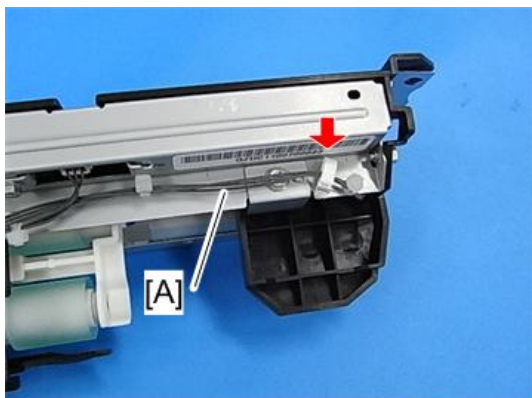

m022r662a

2. Release the harness [A] (🔌 x 1).

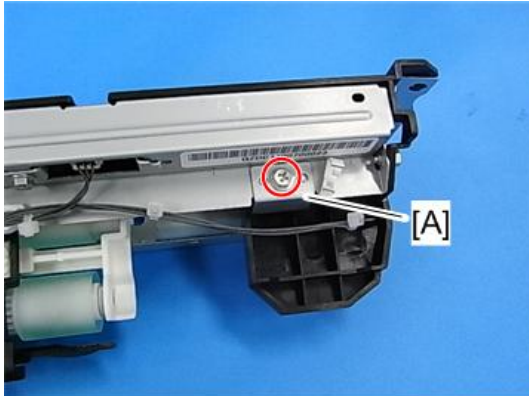

m022r663a

3. Paper feed sensor bracket [A] (🔩 x 1)

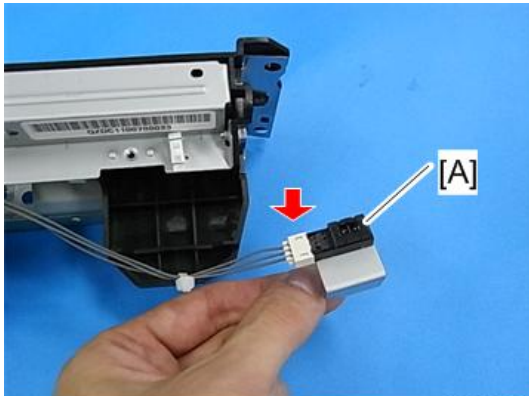

m022r664a

4. Paper feed sensor [A] (🔌 x1, hooks)

Tray Lift Motor

1. Rear cover (🔧 page 213)
2. PSU box (🔧 page 443)
3. BCU bracket (🔧 page 436 "BCU")

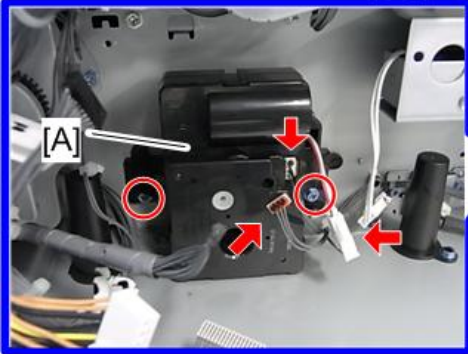
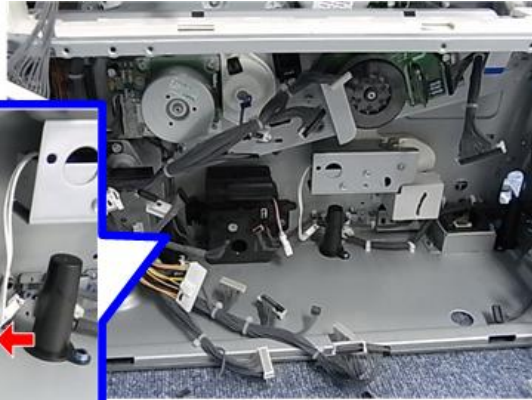

m022r652

4

4. Tray lift motor [A] (🔧 x 2, 🛠️ x 3)

Paper Size Switch

1. Pull out the paper tray.

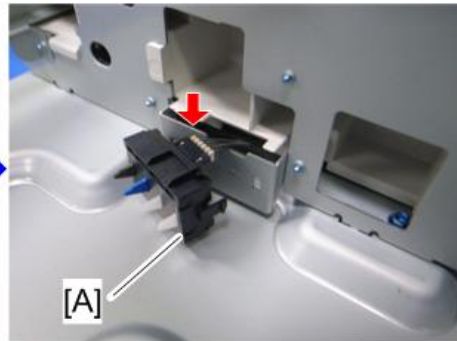
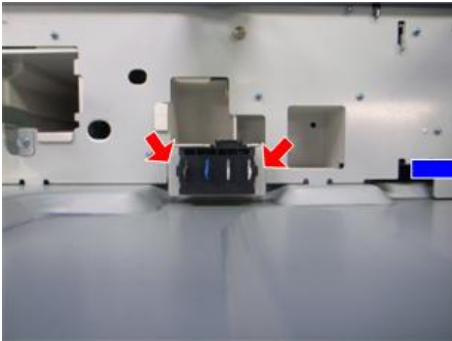

m367r509

2. Paper size switch [A] (🛠️ x 1, hooks)

Cleaning the Paper Dust Container

1. ITB unit (🔧 page 279)
2. PCDU (🔧 page 261)



m065r785

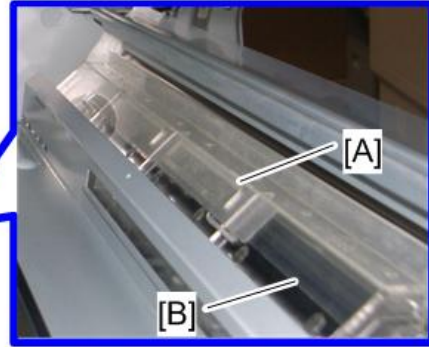

3. Peel off the tape [A] and clean the paper dust container [B] with a vacuum cleaner.

Paper Exit

Paper Exit Unit

Basic model

1. Fusing unit (see page 322)
2. Left cover (see page 211)

4



m022r867

3. Left upper cover [A] (⚙ x 1)

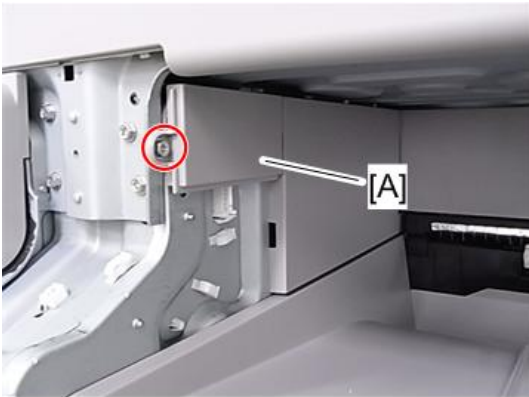

m022r868

4. Inner rear left cover [A] (⚙ x 1)

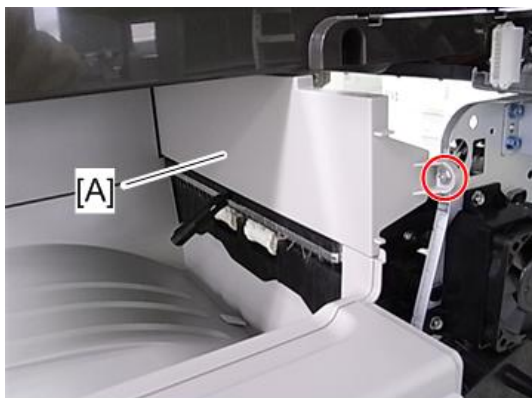

m022r869

5. Paper exit cover [A] (🔩 x 1)

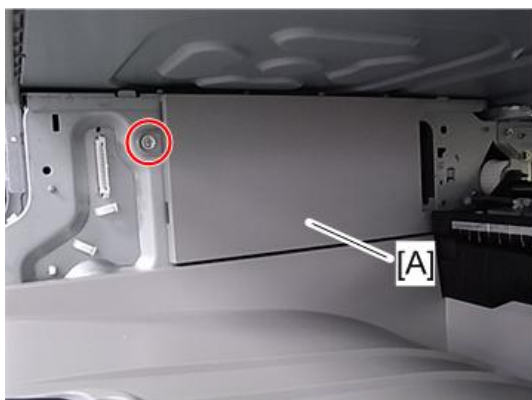

m022r870

6. Inner rear right cover [A] (🔩 x 1)

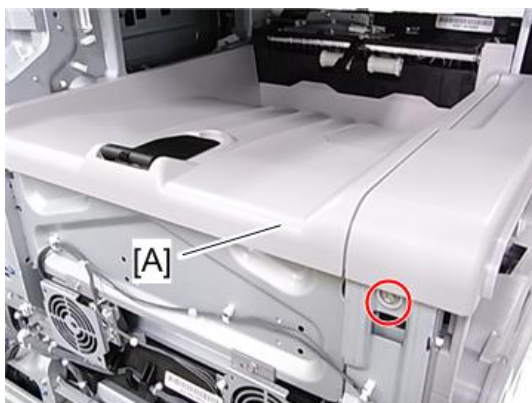

m022r871

7. Paper exit tray [A] (🔩 x 1)



m022r872

4

8. Paper exit unit holder [A] (🔧 x 1)

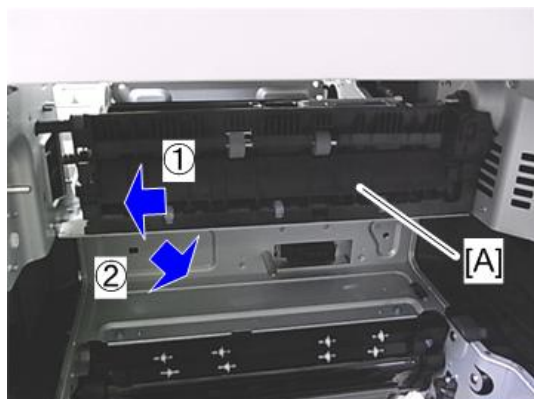

m022r873

9. Paper exit unit [A] (🔧 x 1)

Finisher model

1. Fusing unit (🔧 page 322)



2. Paper exit unit holder [A] (🔩 x 1)

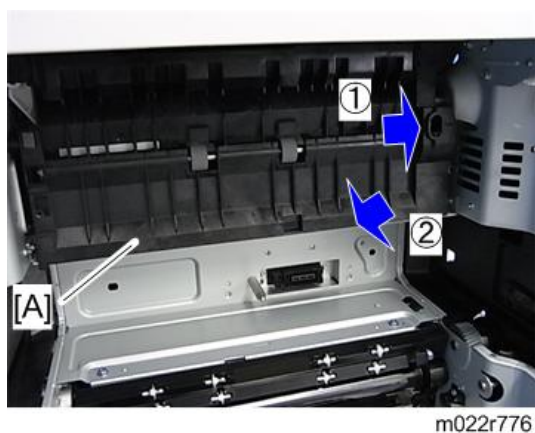

3. Release the paper exit unit [A]

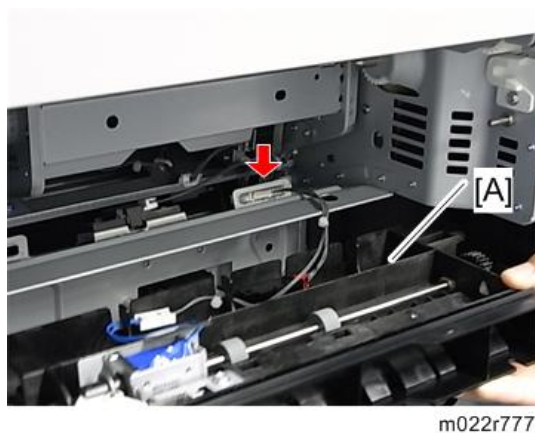

4. Paper exit unit [A] (📄 x 1)

Paper Exit Sensor

Basic model only

1. Paper exit unit (📄 page 358)

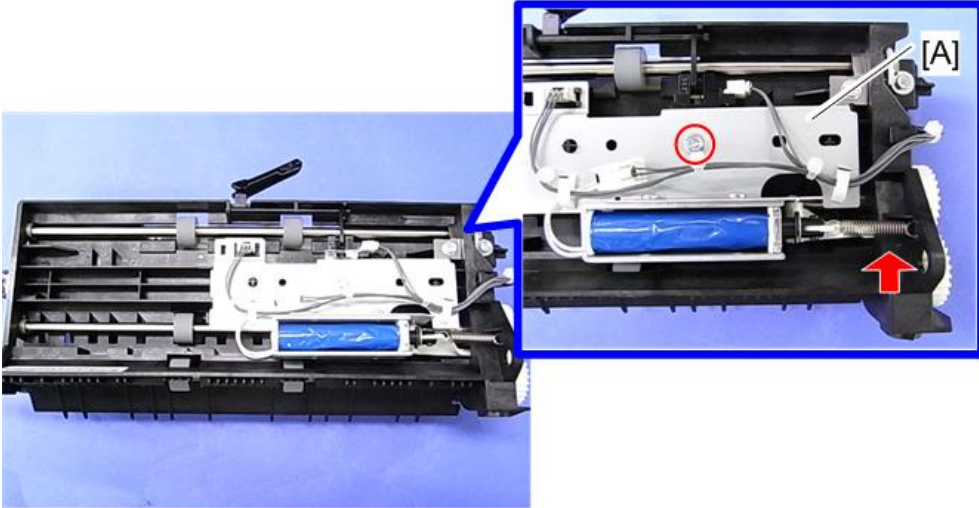

m022r874

2. Sensor bracket [A] (📄 x 1, spring x 1)

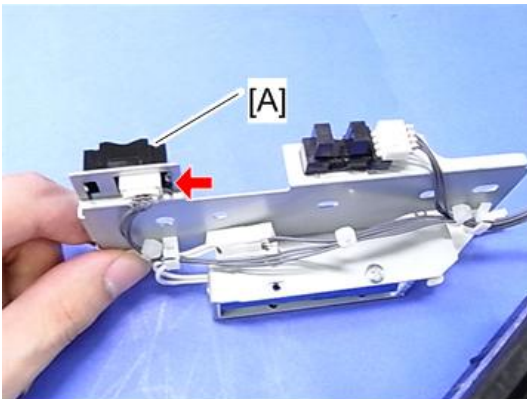

m022r875

3. Paper exit sensor [A] (📄 x 1, hooks)

Paper Overflow Sensor

Basic model only

1. Paper exit unit (📄 page 358)

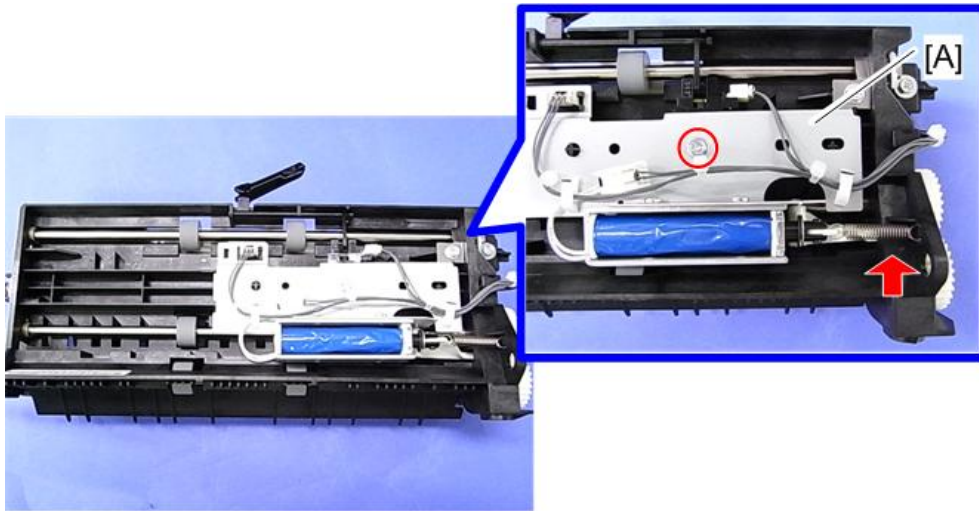

m022r874

2. Sensor bracket [A] (⚙️ x 1, spring x 1)

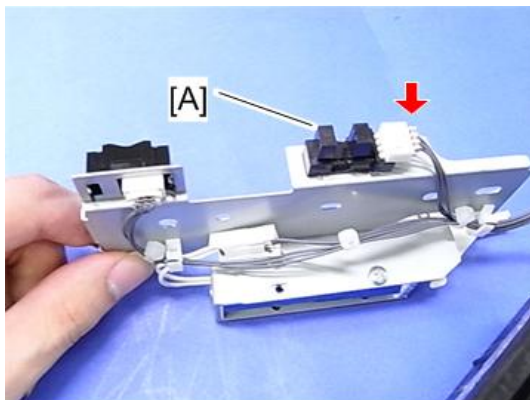

m022r875a

3. Paper overflow sensor [A] (🔌 x 1, hooks)

Fusing Exit Sensor

Basic model

1. Paper exit unit (📄 page 358)

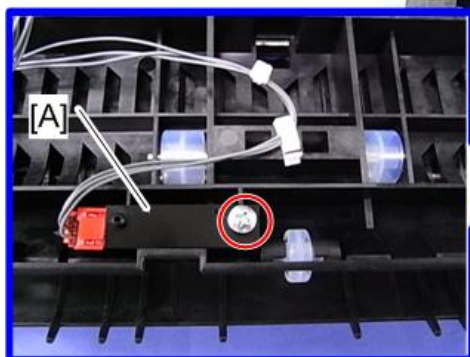
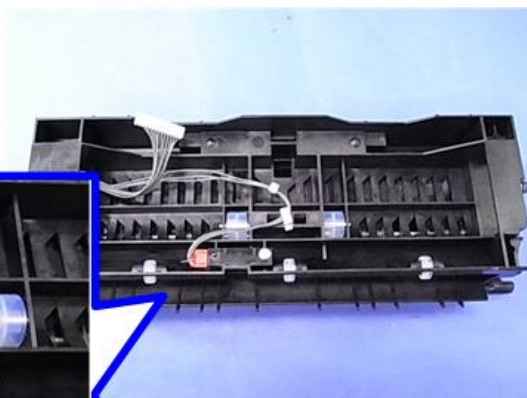

m022r876

2. Remove the screw for the fusing exit sensor [A].

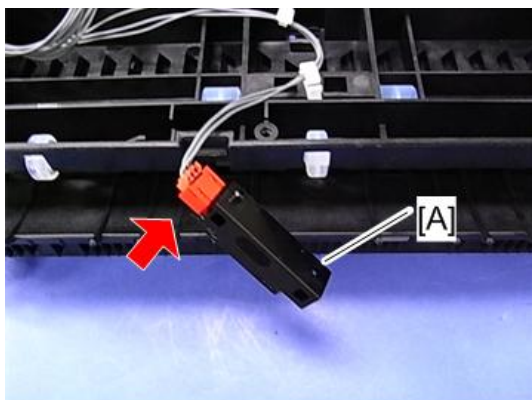

m022r877

3. Fusing exit sensor [A] (📎 x 1)

Finisher model

1. Paper exit unit (📎 page 358)

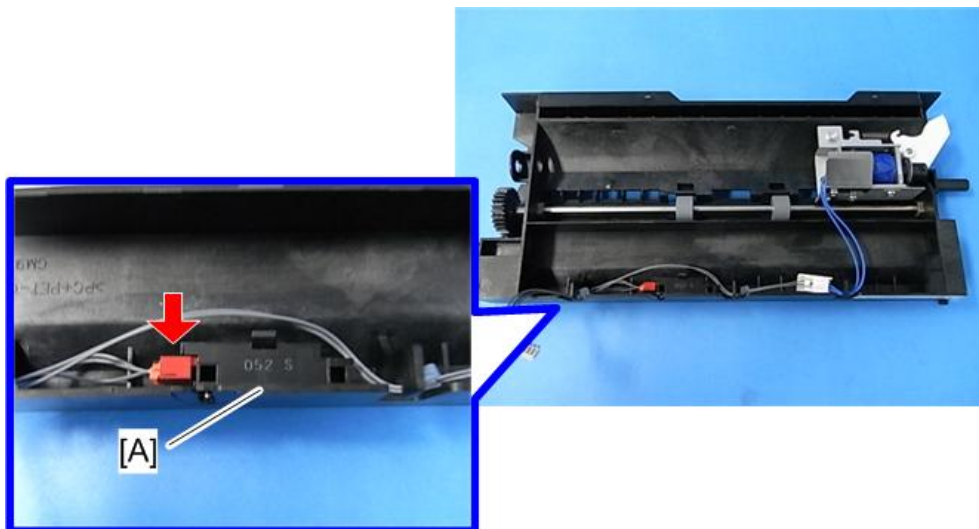

m022r778

- 2. Fusing exit sensor [A] ( x 1, hook x 1)

Duplex Unit

Duplex Unit

1. Right rear cover (☞ page 214)
2. Right front lower cover (☞ page 229 "Inner Right Lower Cover")

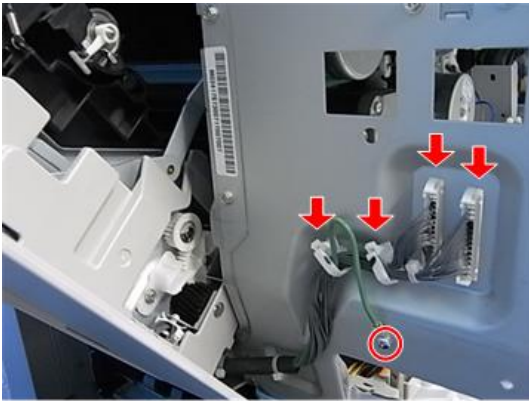

m022r895

3. Remove the screw and disconnect the two harnesses (☞ x 2).

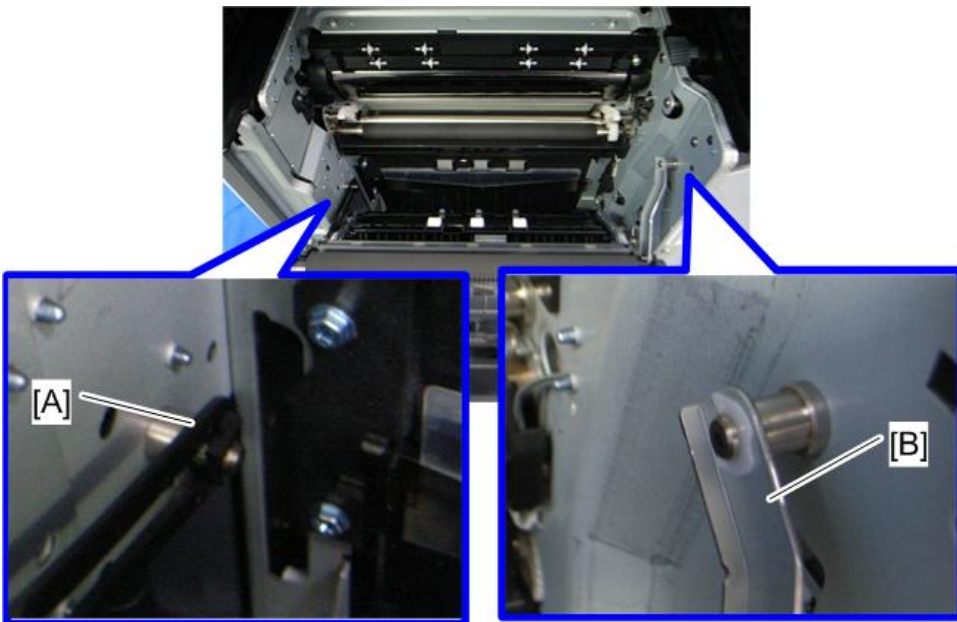

m022r625

4. Release the front and rear arms [A], [B] (☞ x 1 each).

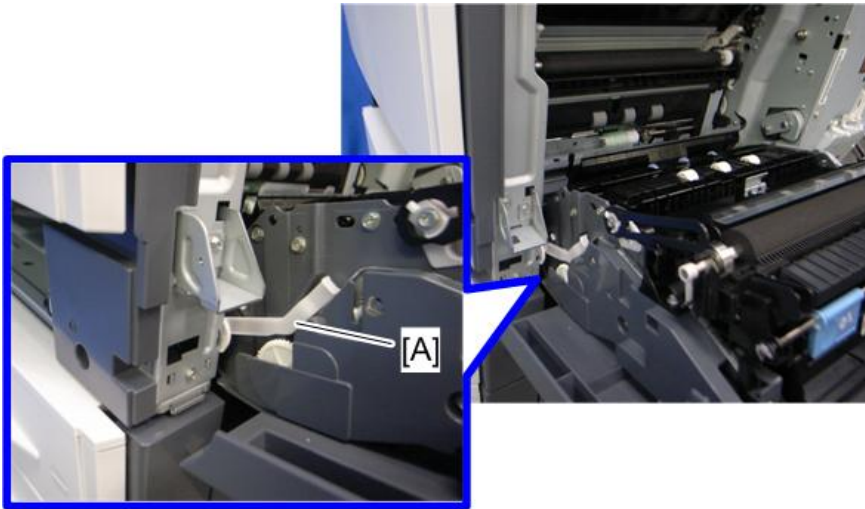

m022r626

5. Remove the long clip [A].

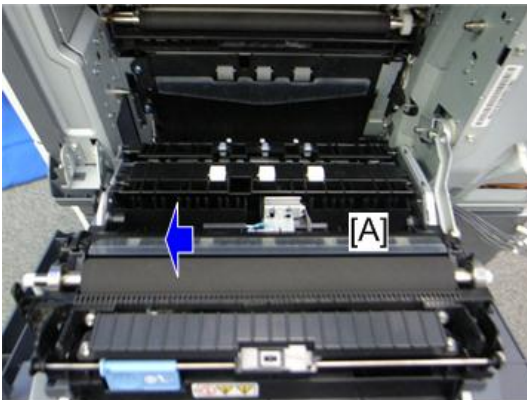

m022r627

6. Slide the duplex unit [A] to the front, and then remove it.

By-pass Tray Unit

1. Duplex unit (see page 366)

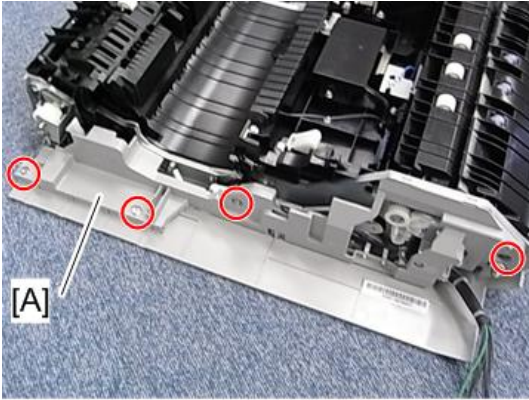

m022r903

4

2. Release the duplex rear cover [A] (🔧 x 4)

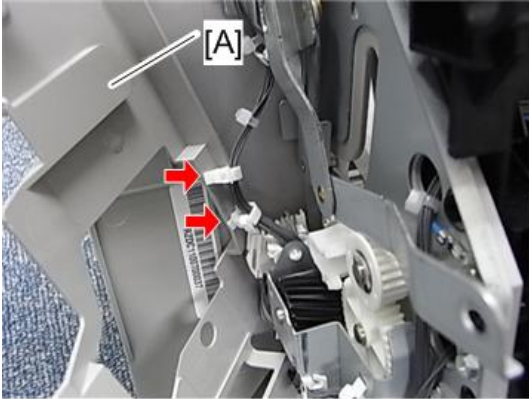

m022r901

3. Duplex rear cover [A] (🔧 x 2)

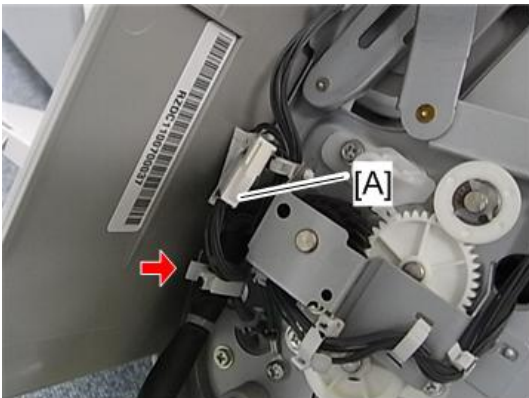

m022r902

4. Disconnect the connector [A] (🔧 x 1)

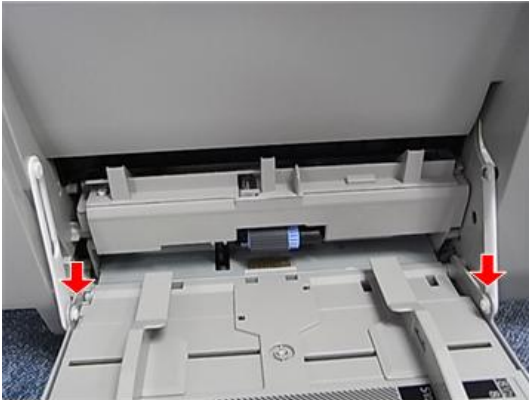

m022r904

5. Remove the two clips.

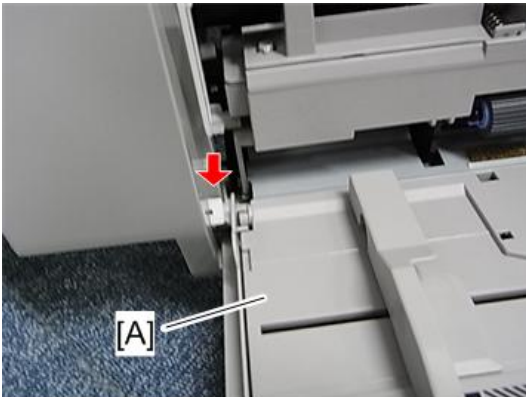

m022r905

6. By-pass tray unit [A] (☞ x 1)

Duplex Entrance Sensor

1. Duplex unit (☞ page 366)

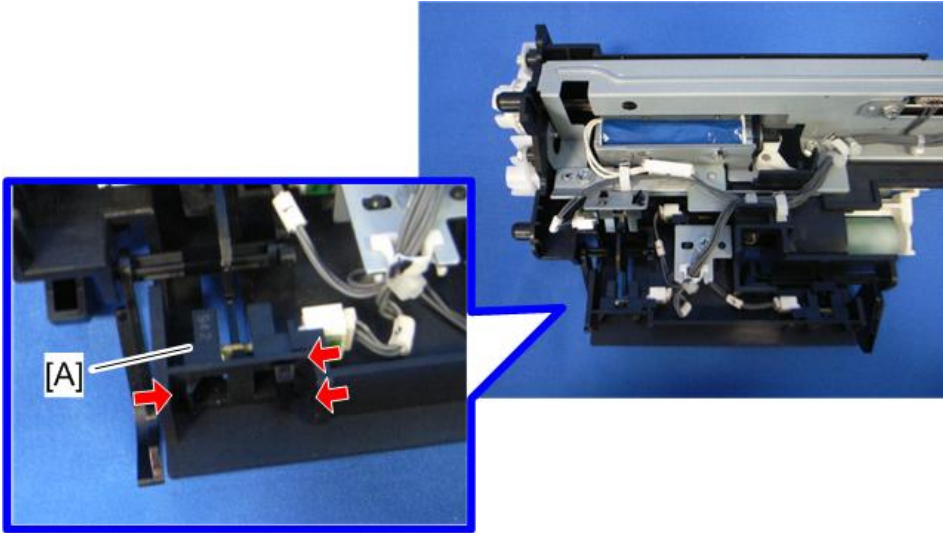

m065r656

2. Sensor bracket [A] (🔧 x 1)

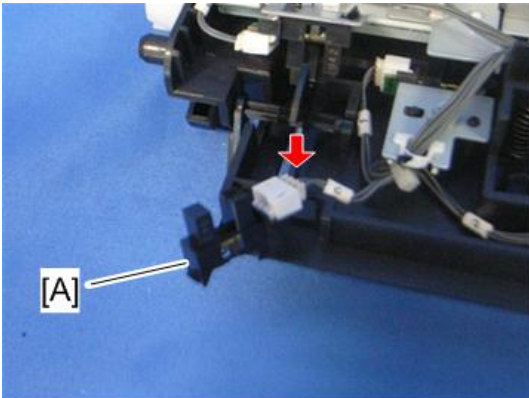

m065r657

3. Duplex entrance sensor [A] (🔧 x 1, hooks)

Duplex Exit Sensor

1. Open the duplex unit.
2. Fusing unit (🔧 page 322)
3. PTR unit (🔧 page 296)

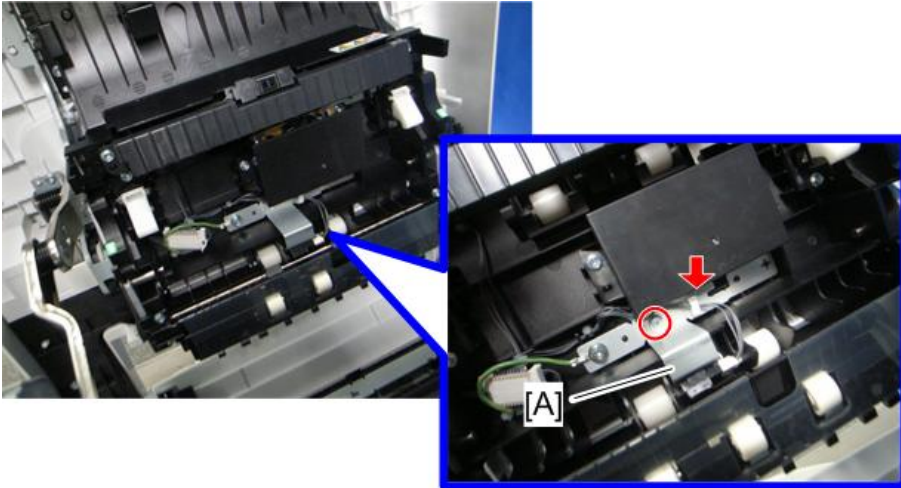

m065r764

4. Release the sensor bracket [A] (🔧 x 1, 📏 x 1).

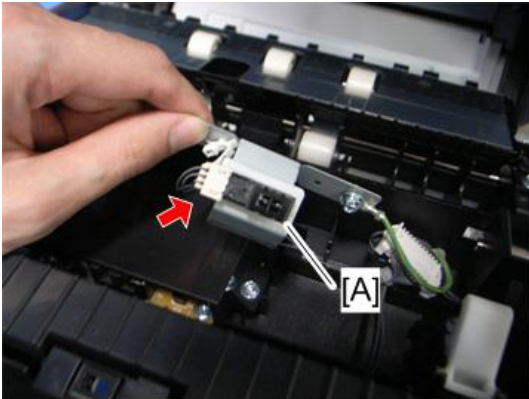

m065r765

5. Duplex exit sensor [A] (📏 x 1, hooks)

Inverter Sensor

1. Duplex unit (📄 page 366)

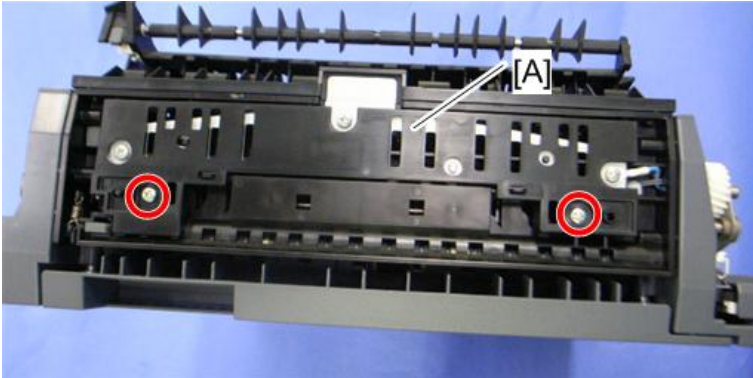

m022r764

4

2. Guide plate [A] (🔩 x 2)

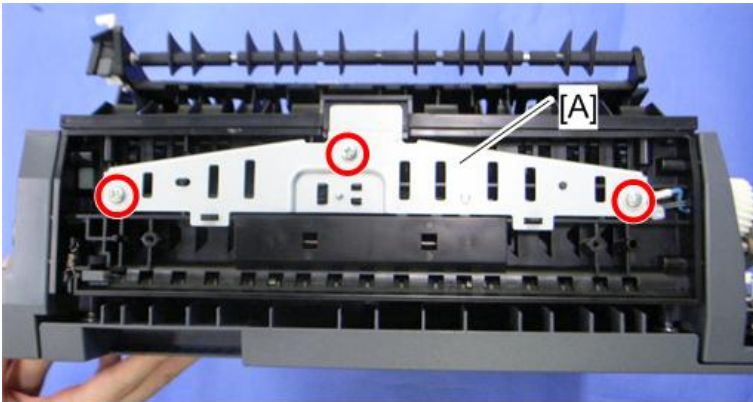

m022r765

3. Bracket [A] (🔩 x 3)

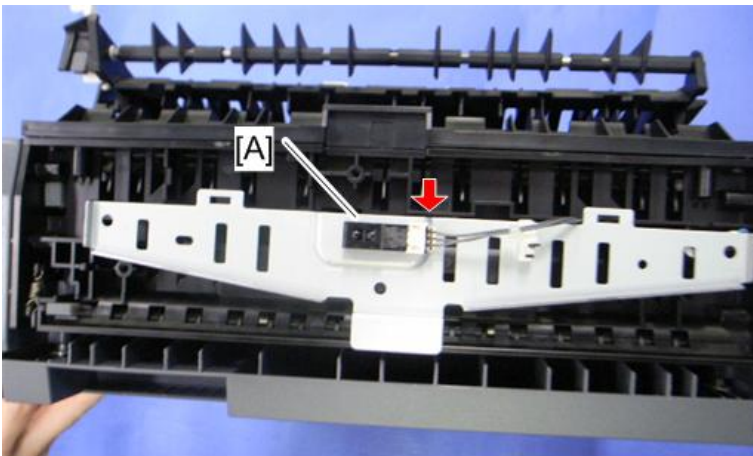

m022r766

4. Inverter sensor [A] (🔌 x 1, hooks)

Fusing Entrance Sensor

1. Open the duplex unit.
2. Fusing unit (📄 page 322)
3. PTR unit (📄 page 296)

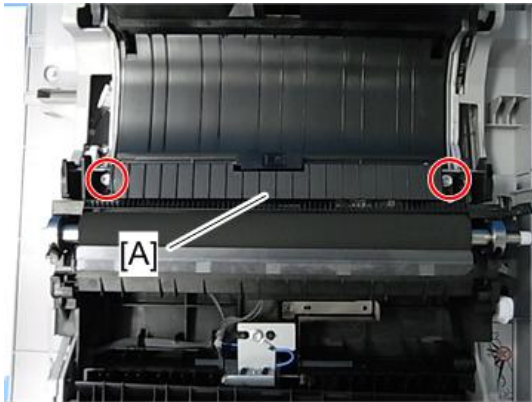

m022r884

4. Sensor base [A] (🔧 x 2)

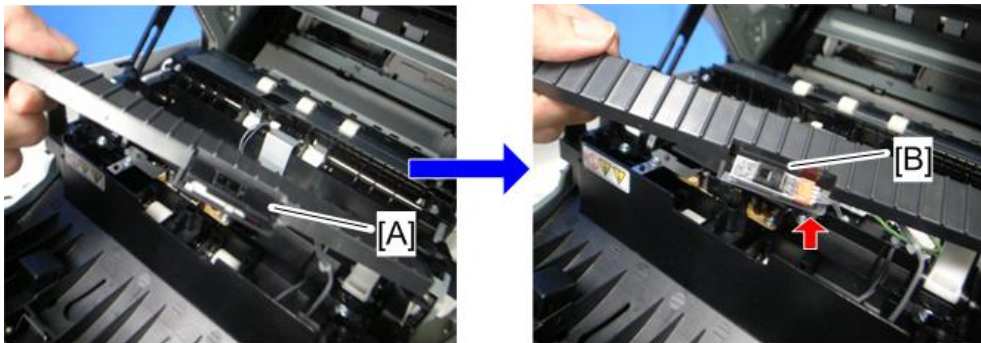

m065r763

5. Sensor cover [A] (hooks)
6. Fusing entrance sensor [B] (🔧 x 1, hooks)

By-Pass Paper Size Sensor

1. By-pass tray unit (📄 page 367)



m022r897

4

2. By-pass tray cover [A] (hooks)

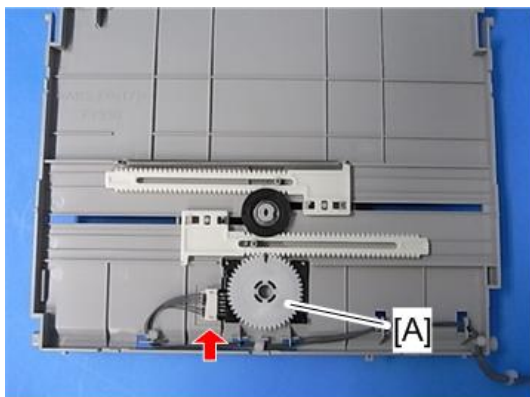

m022r888

3. By-pass paper size sensor [A] (☞ x 1)

When reinstalling the by-pass paper size sensor

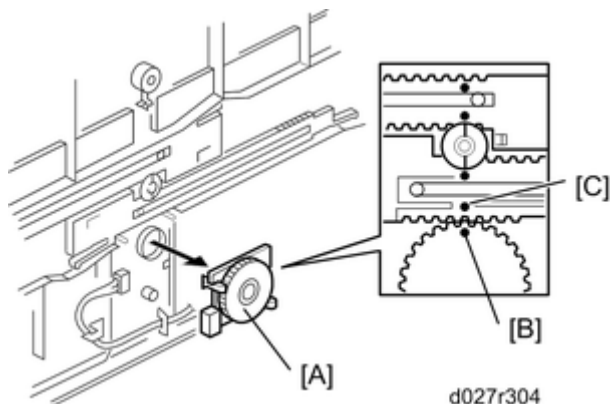

d027r304

1. Adjust the projection [A] of the left side fence bar (it must be centered).
2. Install the by-pass paper size detection switch so that the hole [B] in this switch faces the projection [C] of the left side fence bar.
3. Reassemble the copier.
4. Plug in and turn on the main power switch.
5. Check this switch operation with SP5803-017 (By-Pass Size Detection SW < Input Check).

- Display on the LCD -

Paper Size	Display	Paper Size	Display
A4 SEF	00001101	B6 SEF	00001011
B5 SEF	00001001	A6 SEF	00000011
A5 SEF	00001011	Smaller A6 SEF	00001110

4

By-pass Paper End Sensor

1. By-pass tray unit (see page 367)

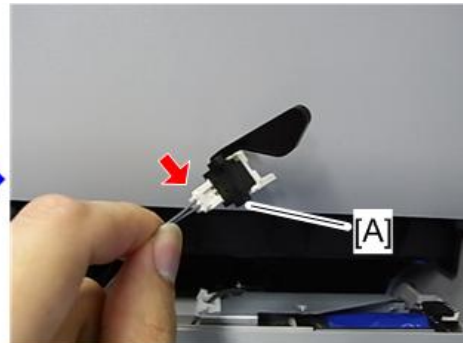
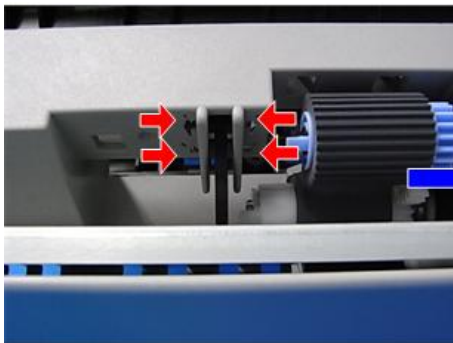

m022r889

2. By-pass paper end sensor [A] (see page 367 x 1, hooks)

By-pass Pick-up Roller

1. Open the by-pass tray.

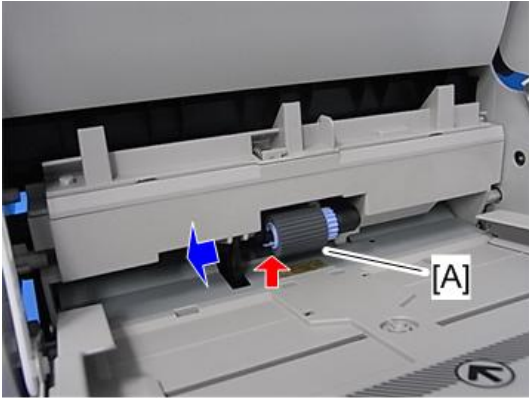

m022r885

4

2. By-pass pick-up roller [A] (hook x 1).

By-pass Feed and Separation Roller

1. By-pass tray unit (☞ page 367)

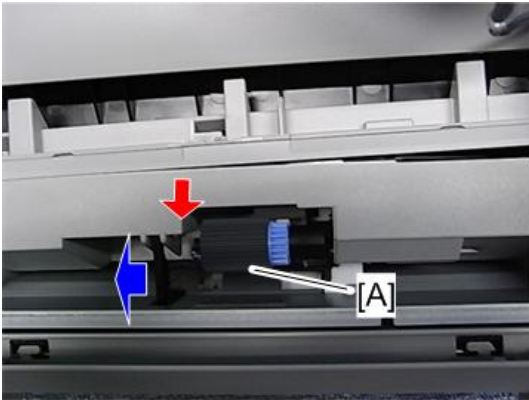

m022r899

2. By-pass pick-up roller [A] (hook x 1).

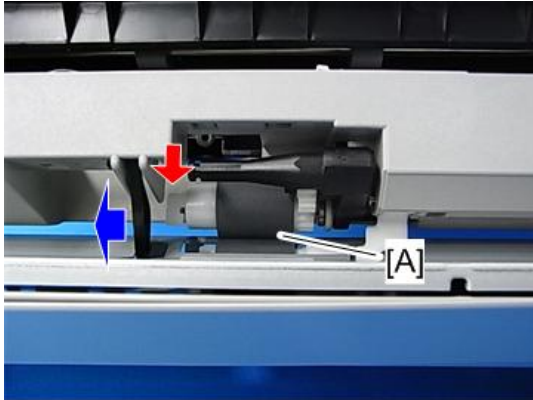

m022r898

3. By-pass feed roller [A] (hook x 1)

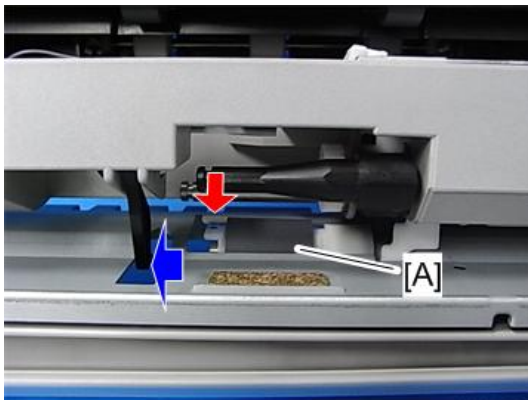

m022r900

4. By-pass separation roller [A] (hook x 1)

HVPS: D

⚠ CAUTION

- Turn off the main power switch and unplug the machine before removing the HVPS: D.
1. Open the duplex unit.
 2. Fusing unit (🔗 page 322)
 3. Paper transfer roller unit (🔗 page 296)
 4. HVPS: D cover [A] (🔗 x 2)

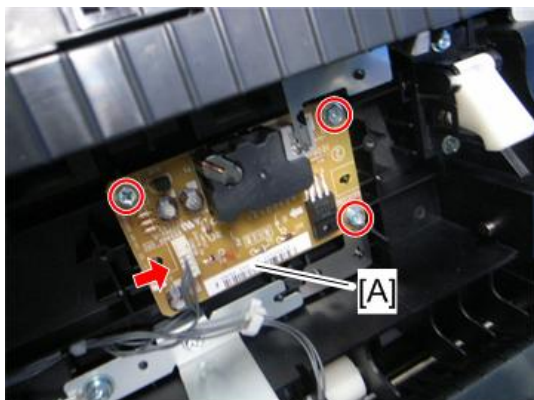

m065r767

4

5. HVPS: D [A] (🔩 x 3, 📏 x 1)

ARDF

ARDF

1. Rear lower cover (🔗 page 212)
2. Rear cover (🔗 page 213)
3. Controller box cover (🔗 page 422)

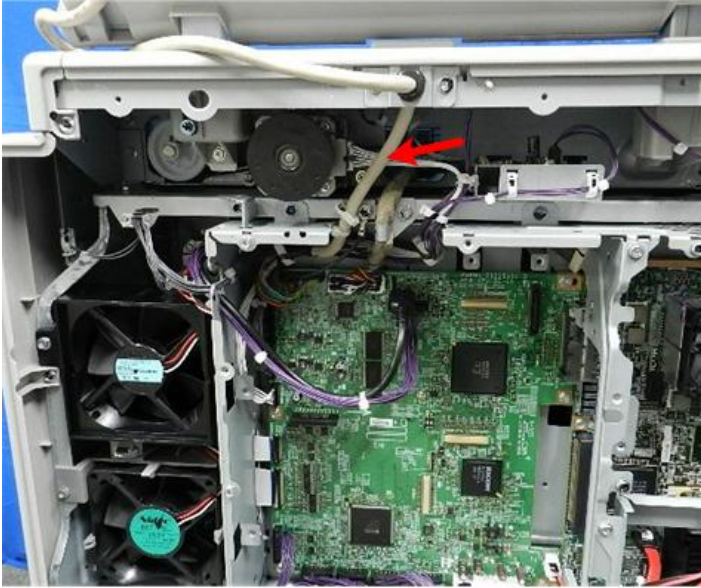

d191b0036

4. The interface cable connects the ARDF to the IPU.

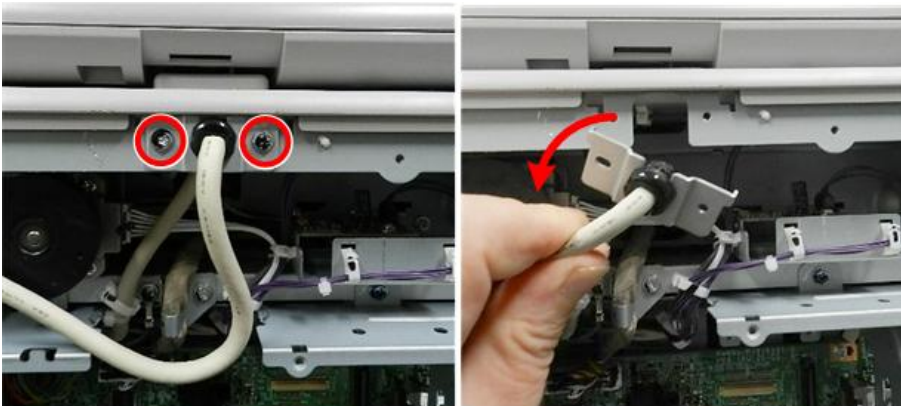

d191b0037

5. Remove the I/F harness bracket (🔗 x2).

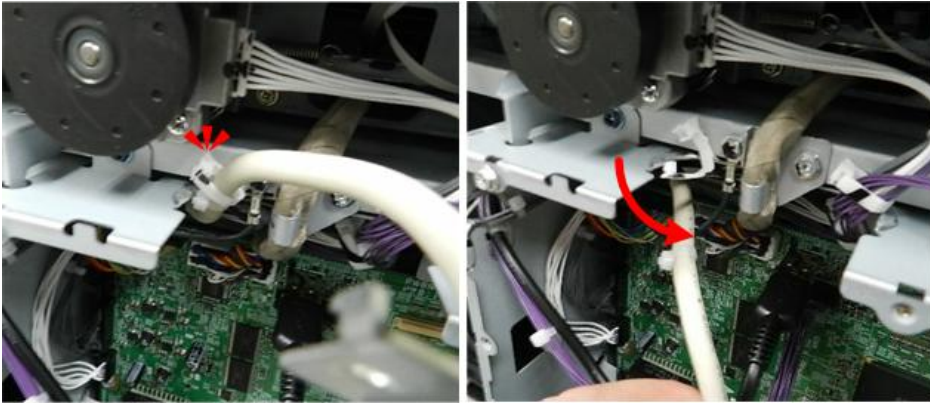

d191b0038

4

6. Open the clamp and free the harness.

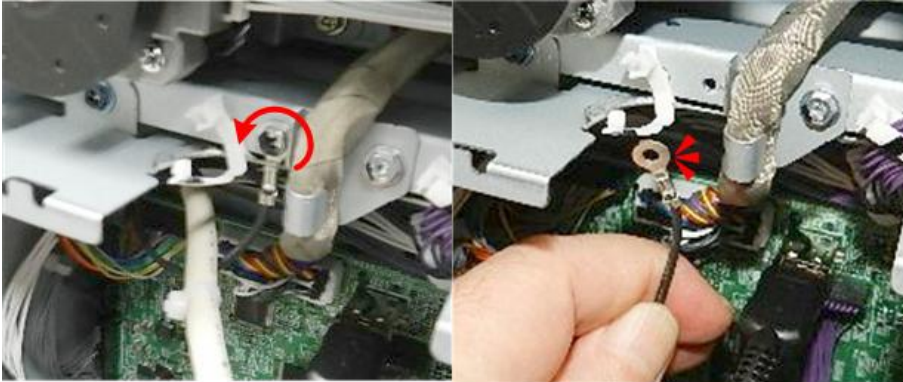

d191b0039

7. Disconnect the ground wire (⌀x1).

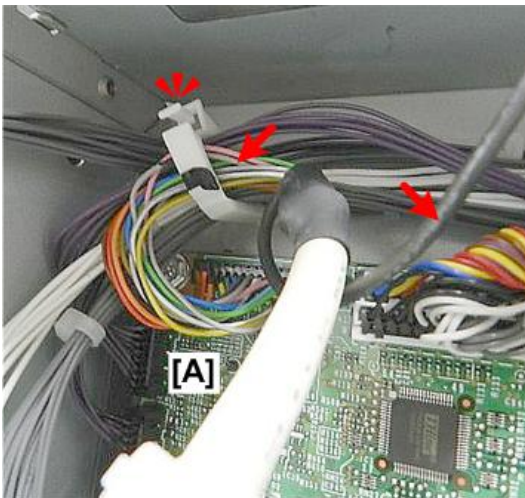

d191b0040

8. Above the upper left corner [A] of the IPU, free the cable harness and ground wire (🔧x1).



d191b0041

9. Disconnect the harness (🔧x1).

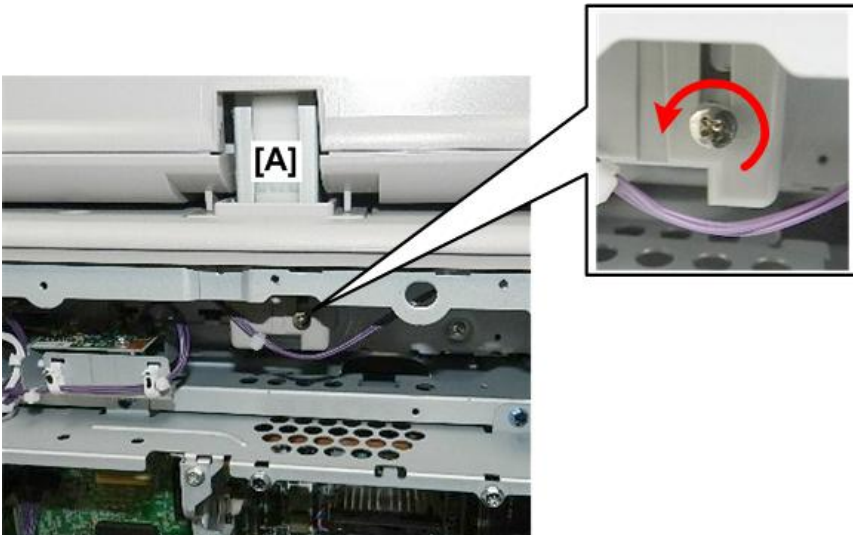

d191b0042

10. Disconnect left hinge [A] (🔧x1).

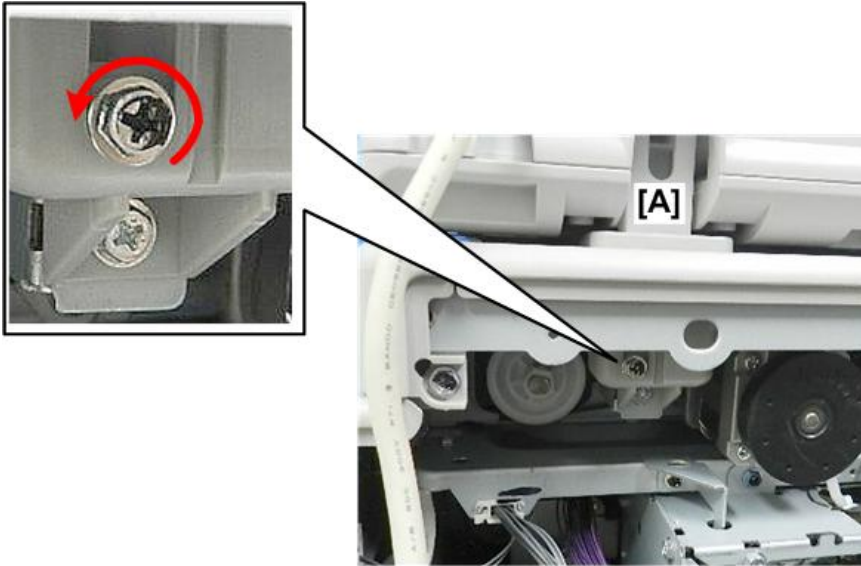

d191b0043

11. Disconnect right hinge [A] (1 x1).



d191b0044

12. Compare the hinge screws.

- The screw with the wide pitch ① is for the plastic right hinge.
- The screw with the narrow pitch ② is for the metal left hinge.
- Be sure re-attach each screw at the correct location.

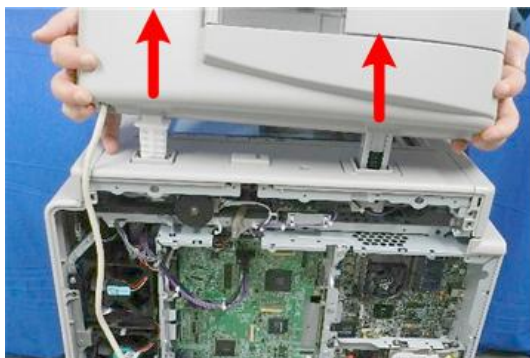

d191b0045

13. Open the ARDF and remove it.

4

When installing the Platen Sheet

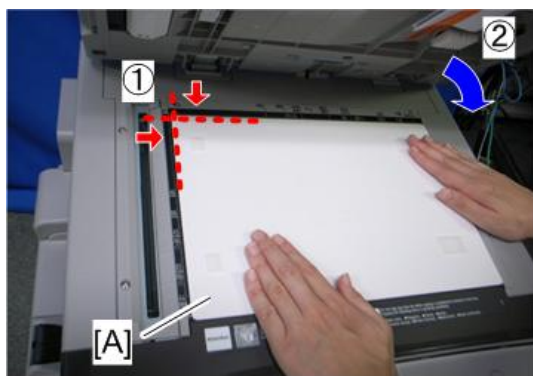

m022i537

When setting the platen cover [A], it is necessary to have a 1 to 2 mm gap on the upper side and on the left side.

ARDF Rear Cover

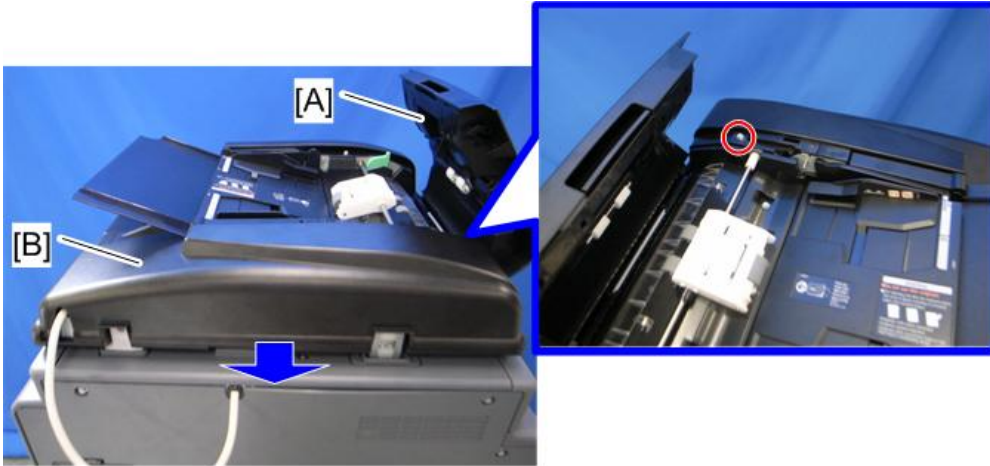

m022r523

1. Open the ARDF left cover [A].
2. ARDF rear cover [B] (🔩 x 1)

ARDF Front Cover and Original Tray

1. ARDF rear cover (🔩 page 384)

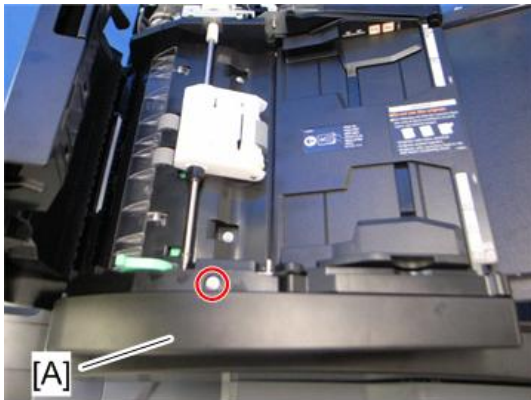

m022r524

2. ARDF front cover [A] (🔩 x 1)

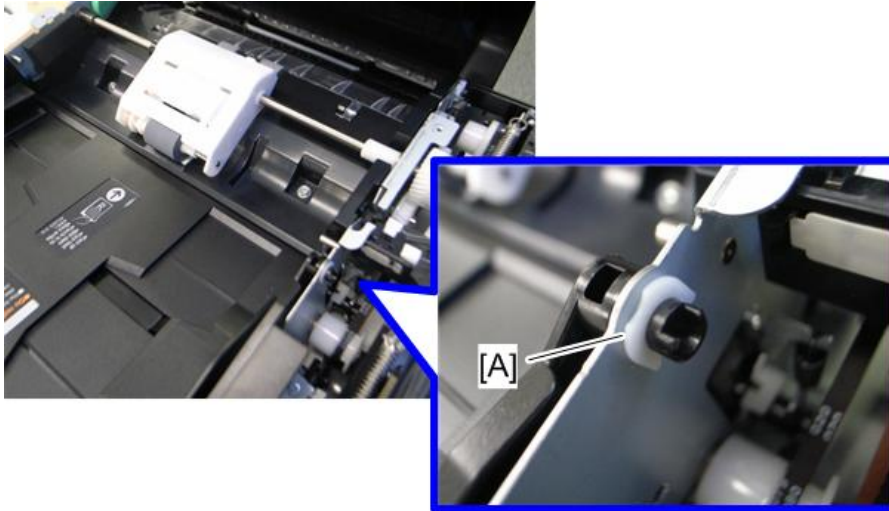

m022r525

3. Remove the snap ring [A].

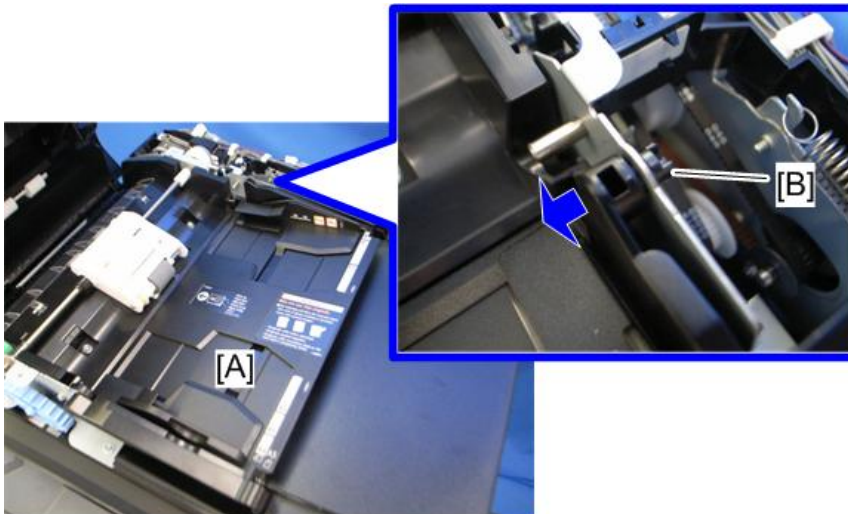

m022r526

4. Remove the original tray [A], and release the rear shaft [B].

Original Feed Unit

1. Open the ARDF left cover (see page 384).

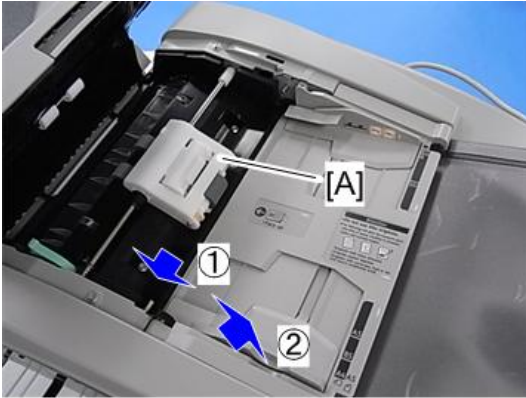

m022r816

4

2. Original feed unit [A].

Pick-Up Roller

1. If you install a new pick-up roller, set SP 3902-206 to "1".

Note

- If you do this, then the machine will reset the PM counter for the ADF Pickup Roller automatically, after you turn the power on again.

2. Original feed unit (see page 385)

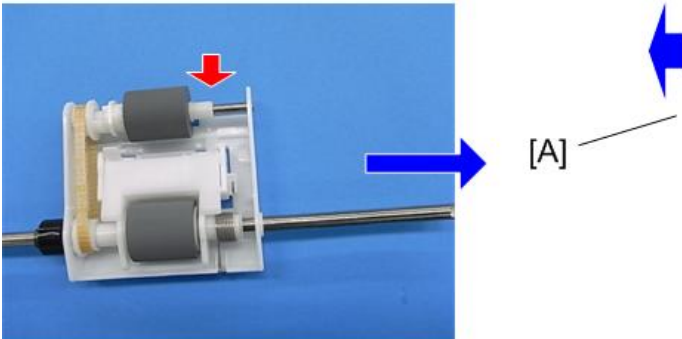

m022r817

3. Slide the shaft [A] (hook x 1).

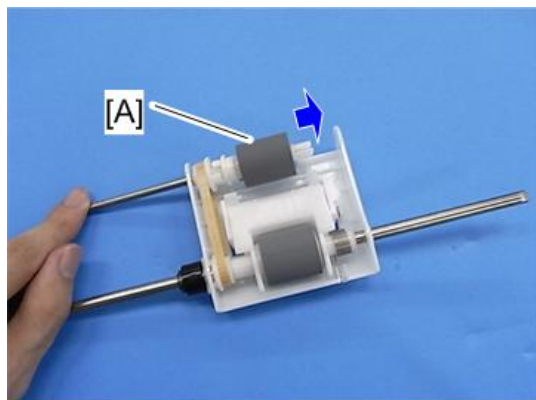

m022r818

4. Pick-up roller [A]

Feed Roller

1. If you install a new feed roller, set SP 3902-207 to "1".

Note

- If you do this, then the machine will reset the PM counter for the ADF Feed Roller automatically, after you turn the power on again.

2. Original feed unit (see page 385)

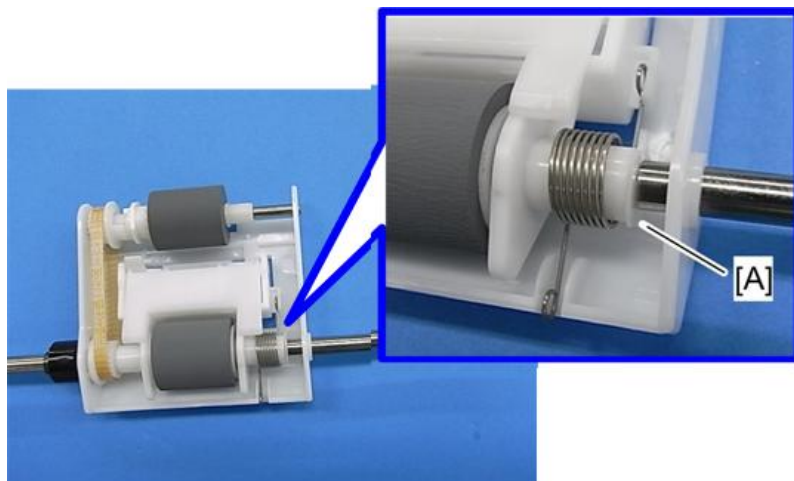

m022r819

3. Remove the clip [A].

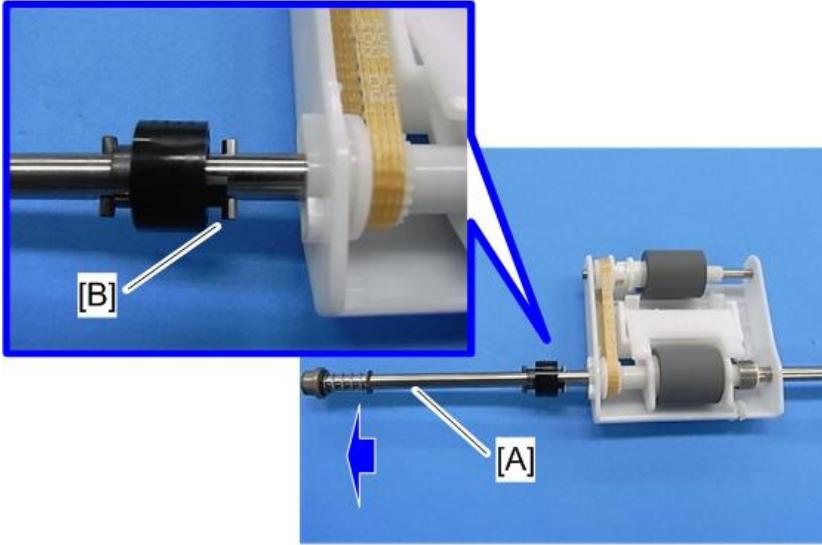

m022r820

4. Slide the shaft [A], and then remove the pin [B].

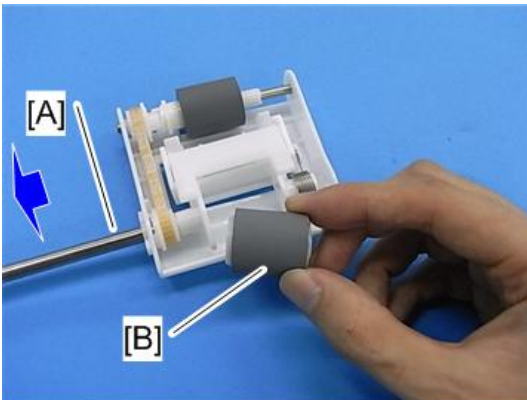

m022r821

5. Slide the shaft [A], and then remove the feed roller [B].

Friction Pad

1. If you install a new friction pad, set SP 3902-208 to "1".

Note

- If you do this, then the machine will reset the PM counter for the ADF Friction Pad automatically, after you turn the power on again.

2. Original feed unit (page 385)

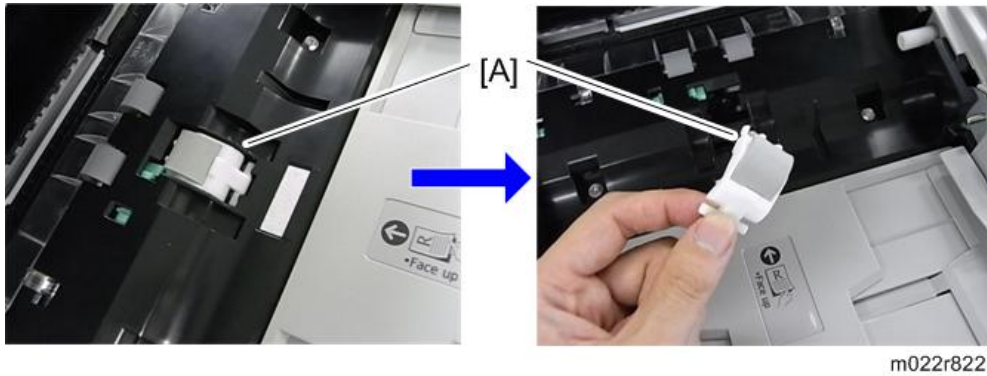

m022r822

3. Friction pad [A] (hooks)

4

ARDF Drive Board

1. ARDF rear cover (🔧 page 384)

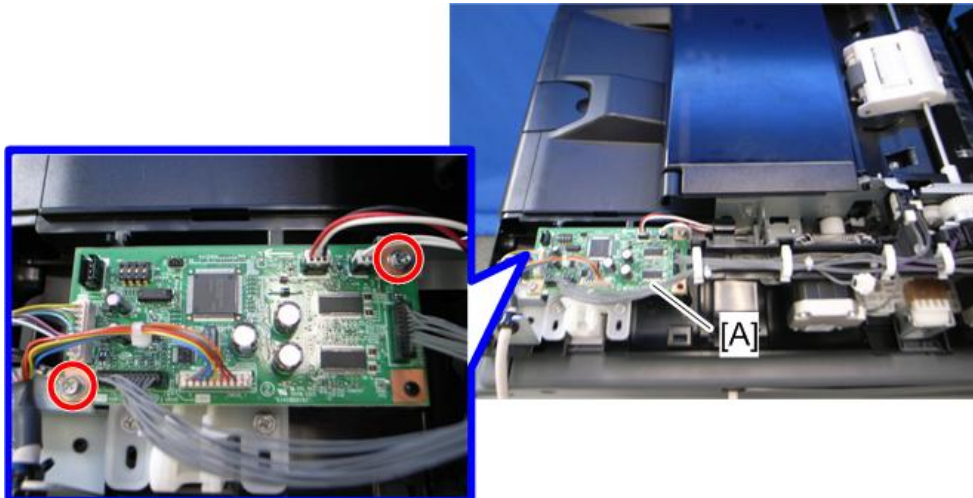

m022r527

2. ARDF drive board [A] (🔧 x 2, all 📁s)

Original Set Sensor and ARDF Top Cover Sensor

1. ARDF rear cover (🔧 page 384)

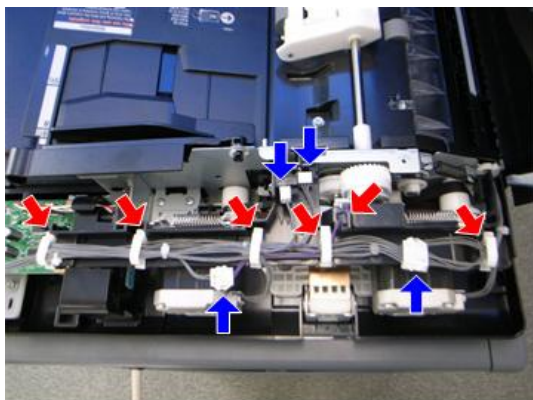

m022r528

4

2. Release the six clamps and disconnect the four connectors.



m022r826

3. Remove the screw.

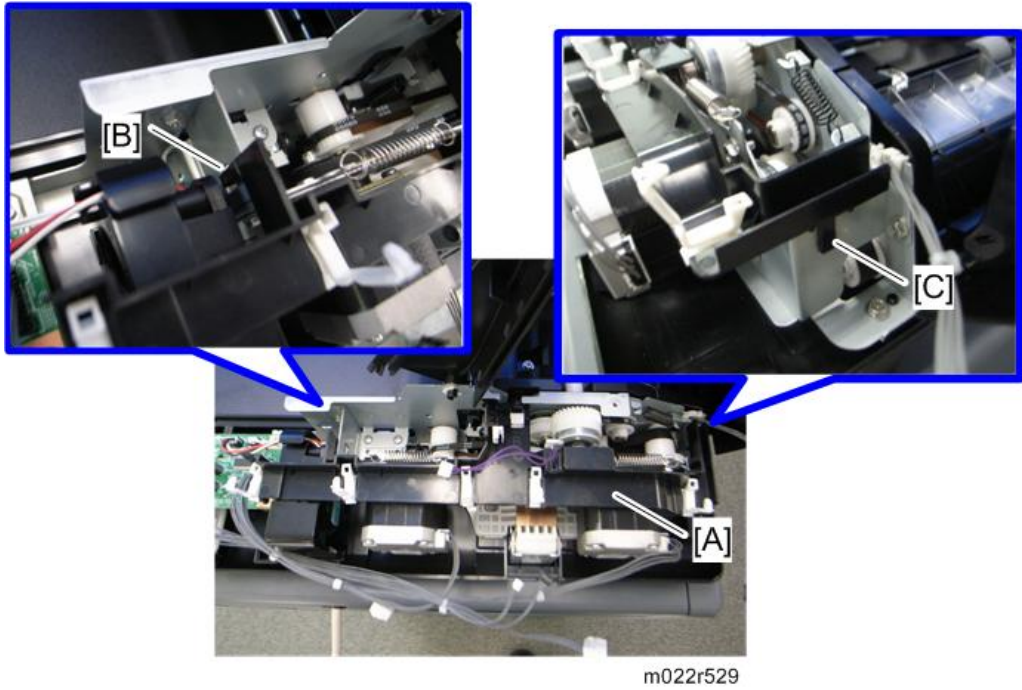

4. Remove the harness guide [A], and release the hooks [B] [C].

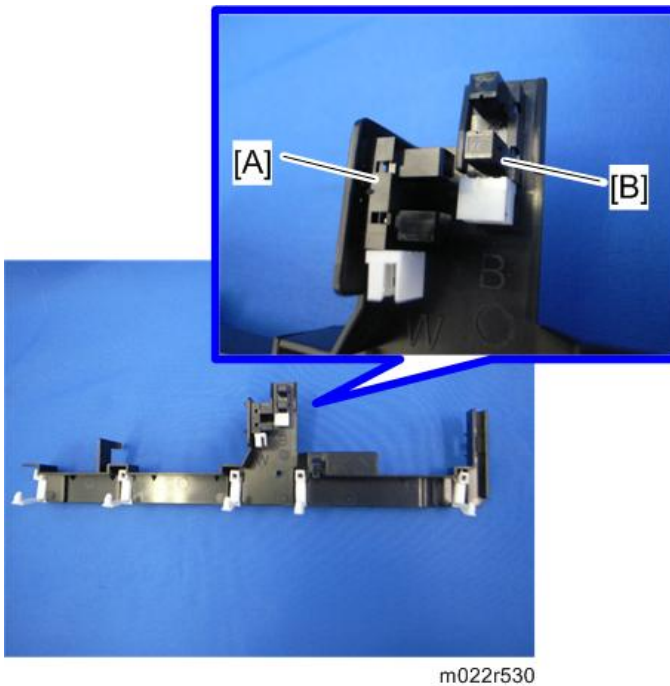

5. ARDF top cover sensor [A] (hooks)
 6. Original set sensor [B] (hooks)

Feed Motor

1. ARDF rear cover (see page 384)

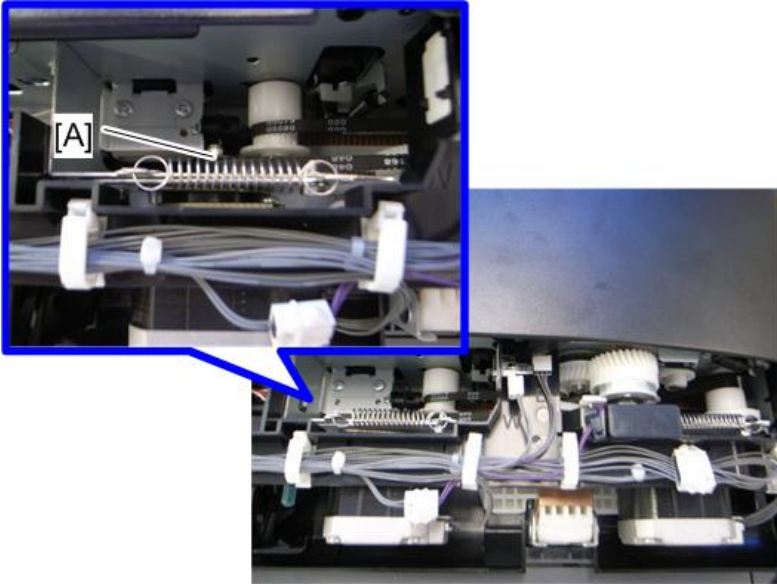

m022r531

2. Remove the spring [A].

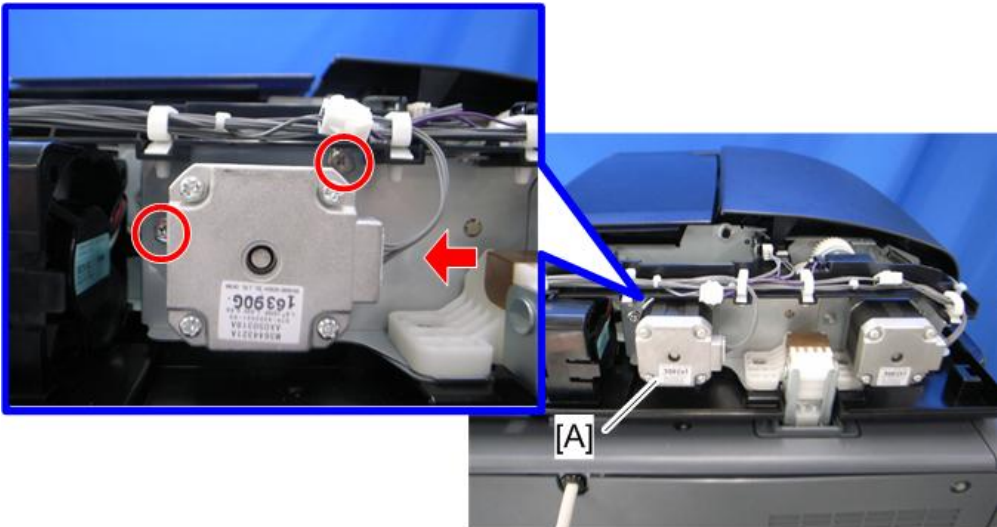

m022r532

3. Feed motor with bracket [A] (🔩 x 2, 📏 x 1)

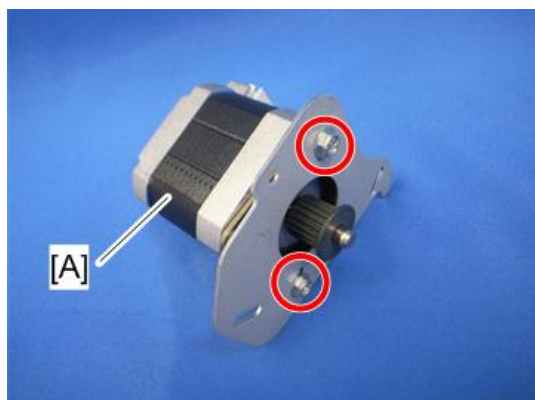

m022r533

4. Feed motor [A] (🔧 x 2)

4

Feed Clutch

1. ARDF rear cover (🔧 page 384)
2. Harness guide (🔧 page 389 "Original Set Sensor and ARDF Top Cover Sensor")

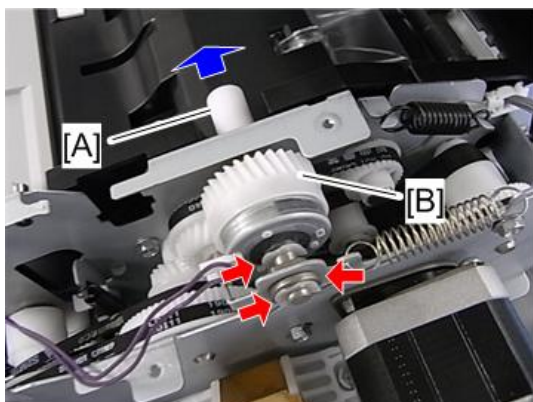

m022r827

3. Slide the shaft [A], and then feed clutch [B] (🔧 x 2, bushing x 1)

Transport Motor

1. ARDF rear cover (🔧 page 384)

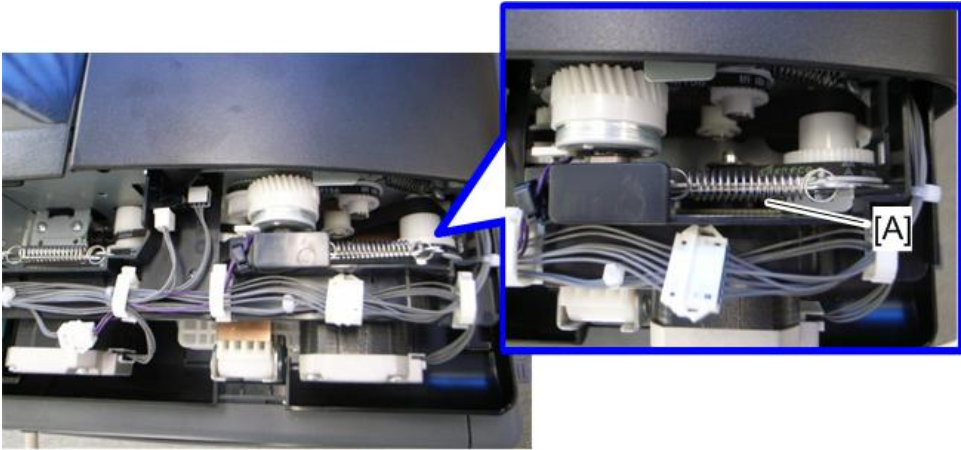

m022r534

2. Remove the spring [A].

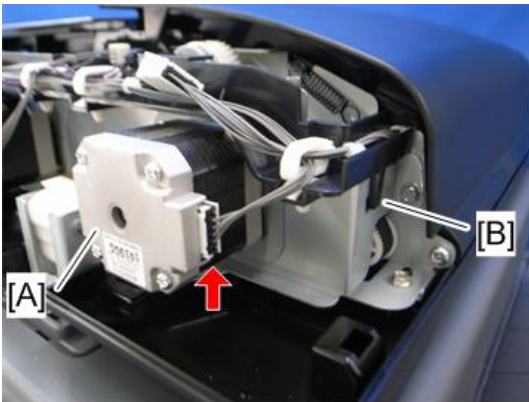

m022r535

3. Disconnect the harness of the transport motor [A].
4. Release the hook [B] of the harness guide.

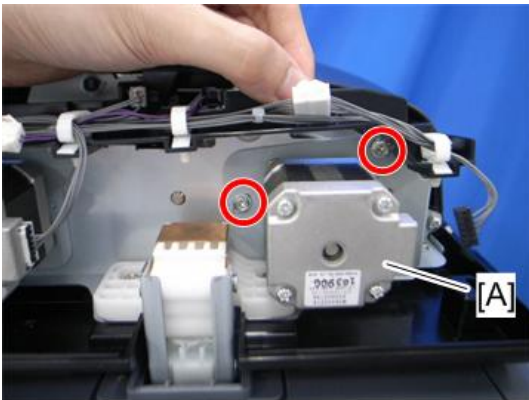

m022r536

5. Transport motor with bracket [A] (hook x 2)

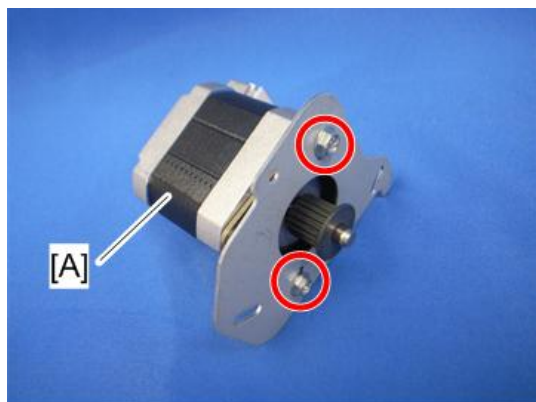

m022r533

4

6. Transport motor [A] (hook x 2)

Registration Sensor

1. Open the ARDF.

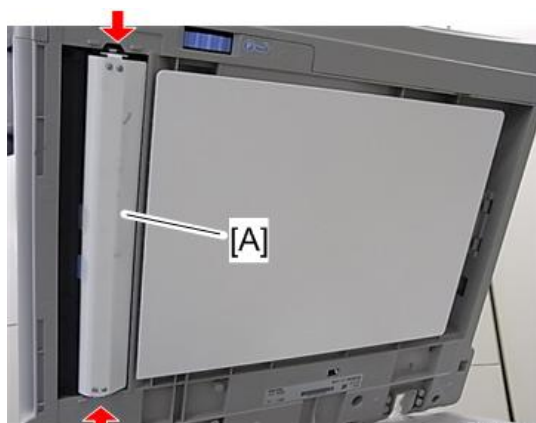

m022r828

2. Bracket [A] (hook x 2)

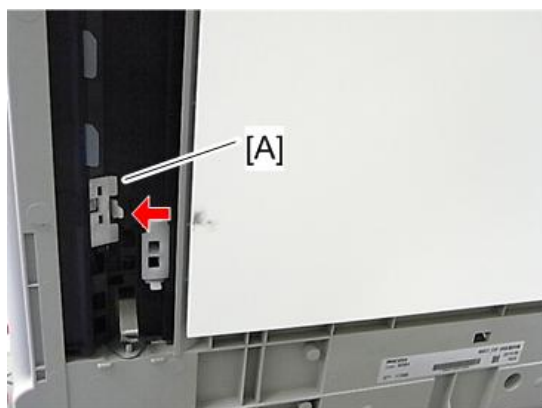

m022r829

4

3. Registration sensor holder [A] (hook x 1)

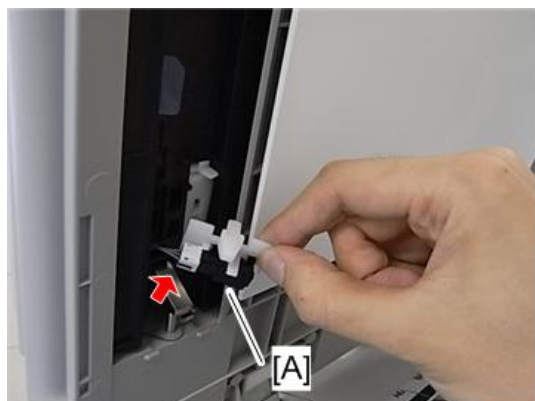

m022r830

4. Registration sensor (📄 x 1, hooks)

Inverter Sensor

1. Open the ARDF.

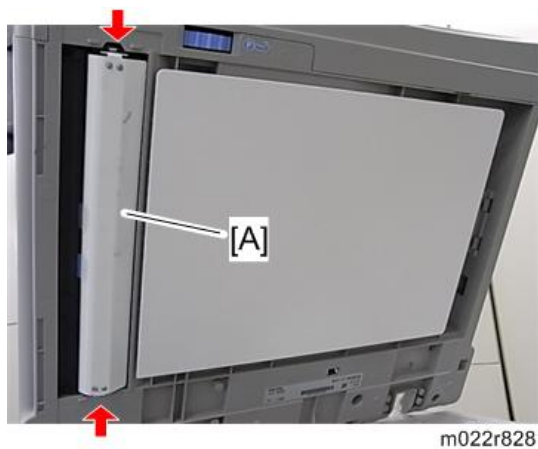

2. Bracket [A] (hook x 2)

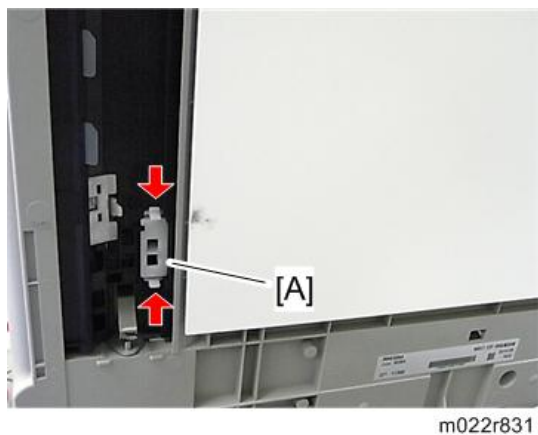

3. Inverter sensor holder [A] (hook x 2)

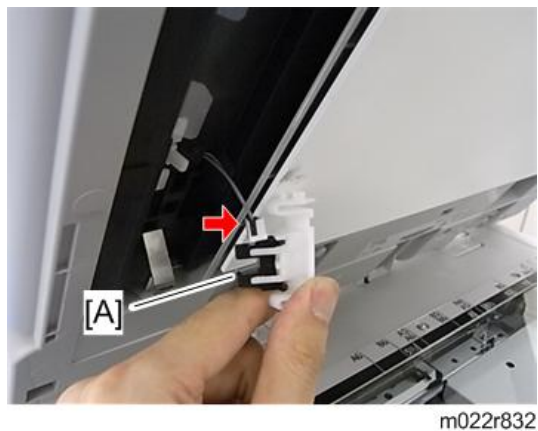

4. Inverter sensor (🔌 x 1, hooks)

Cooling Fan

1. ARDF rear cover (see page 384)

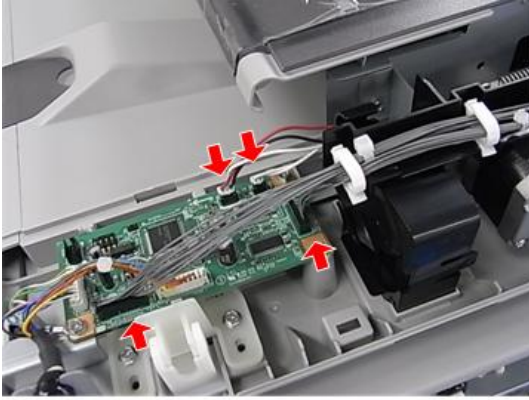

m022r823

2. Disconnect the four connectors.

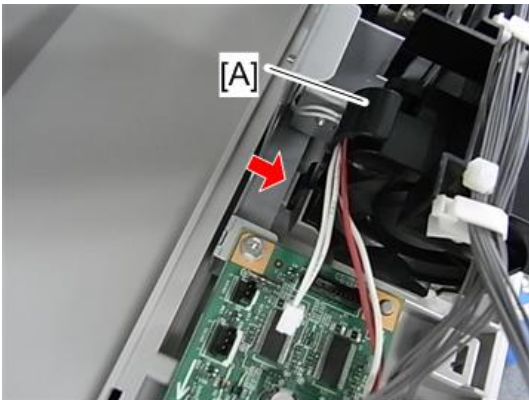

m022r824

3. Fan cover [A] (hook x 1)

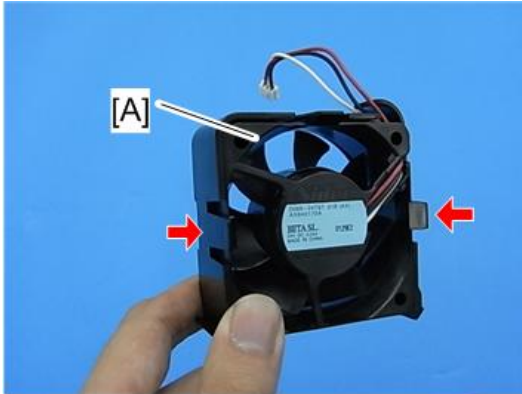

m022r825

4. Cooling fan [A] (hook x 2)

4

When installing the cooling fan

Make sure that the cooling fan is installed with its decal facing the left of the machine.

Internal Finisher

Note

- This section is for the finisher model (D193).

Internal Finisher

1. Inner right cover (☞ page 226)

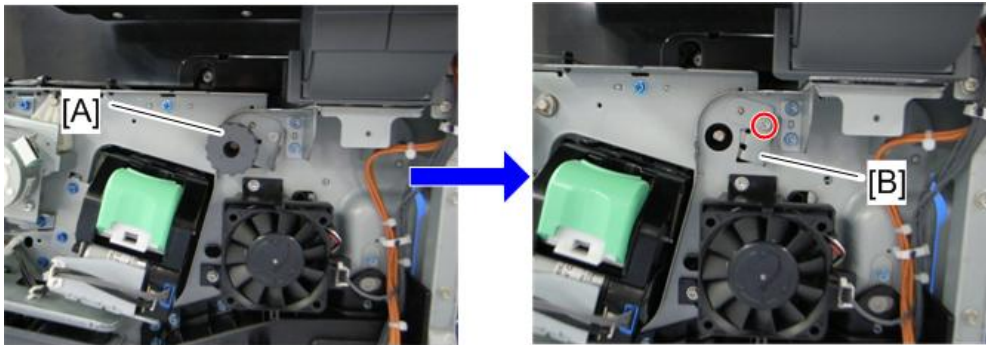

m022r628

2. Remove the knob [A], and then remove the bracket [B] (☞ x 1).

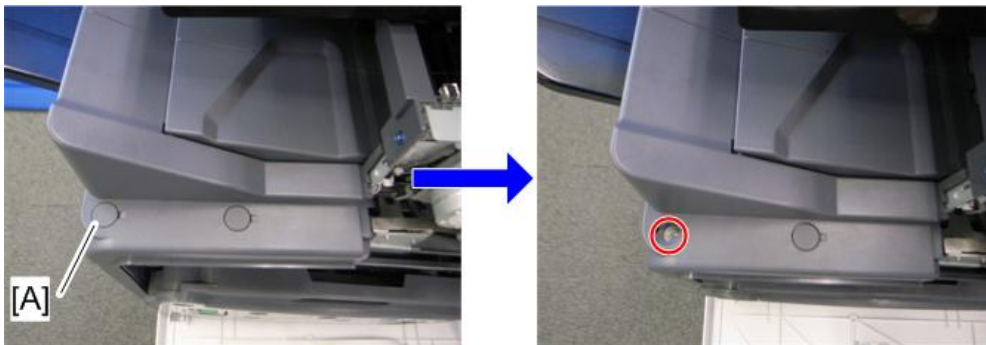

m022r629

3. Remove the cap [A], and then remove the screw.

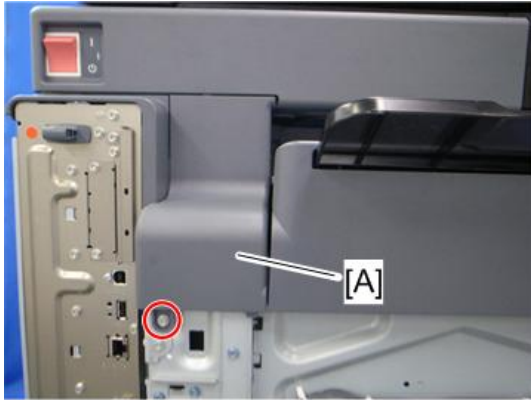

m022r630

4. Left upper cover [A] (⚙️ x 1)



m022r631

5. Inner rear left cover [A] (⚙️ x 1)



m022r632

6. Disconnect the harness [A] and remove the screw.

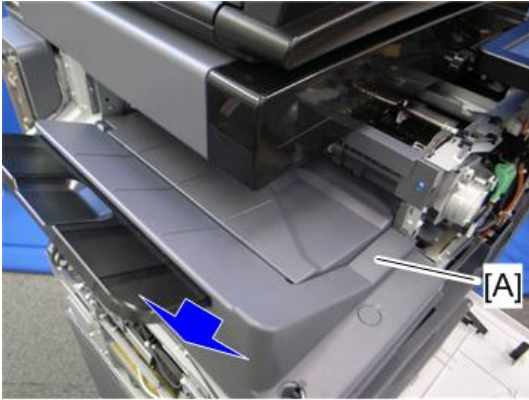

m022r633

4

7. Internal finisher [A]

Output Tray Unit

1. Internal finisher (☞ page 400)

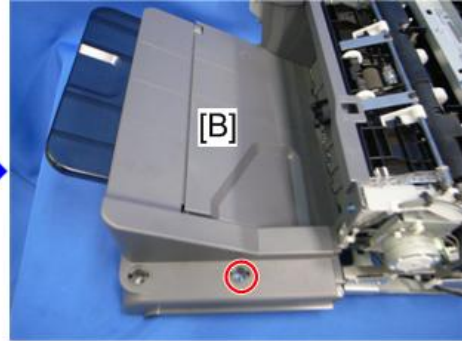
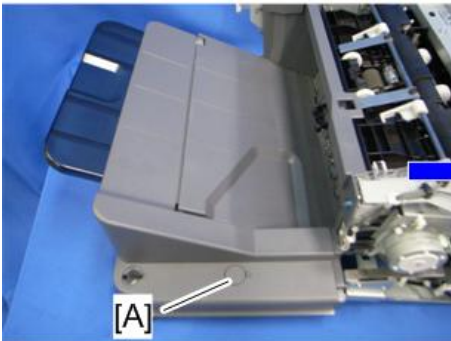

m022r634

2. Remove the cap [A].

3. Output tray unit [B] (☞ x 1)

Stapler Unit

1. Internal finisher (☞ page 400)

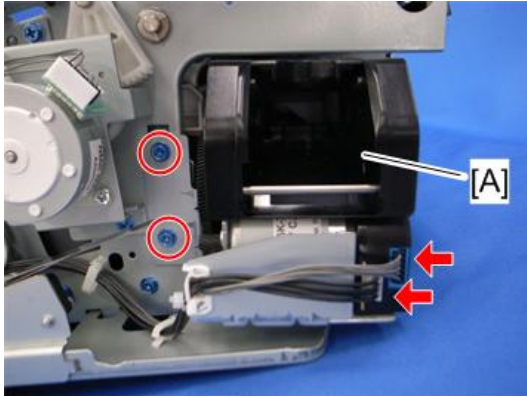

m022r635

2. Stapler unit with bracket [A] (🔩 x 2, 📏 x 2)

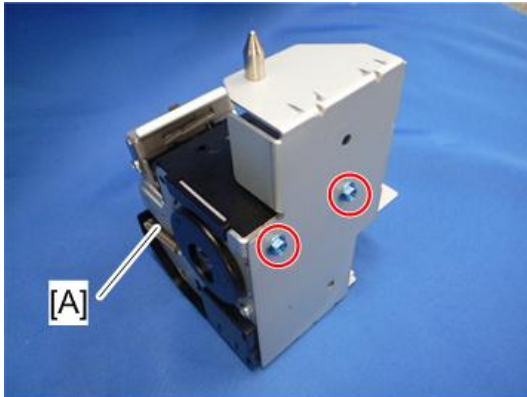

m022r636

3. Stapler unit [A] (🔩 x 2)

Gathering Roller Motor

1. Internal finisher (📄 page 400)

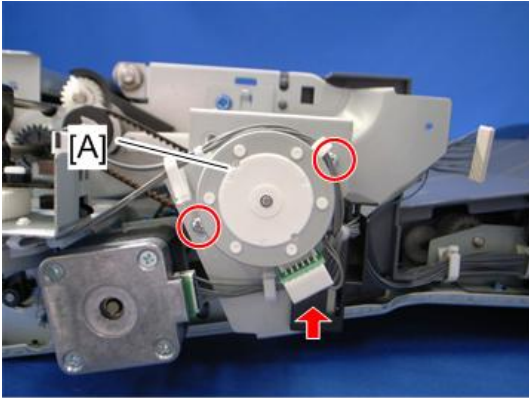

m022r637

4

- 2. Gathering roller motor [A] (⚙ x 2, 📡 x 1)

Paper Exit Motor

- 1. Internal finisher (📖 page 400)

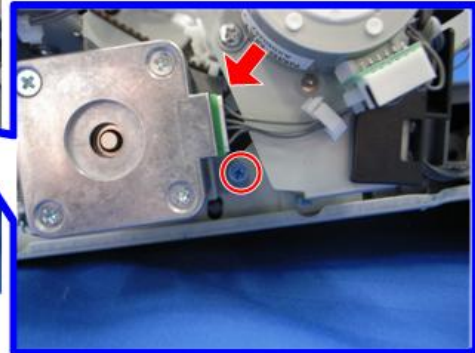
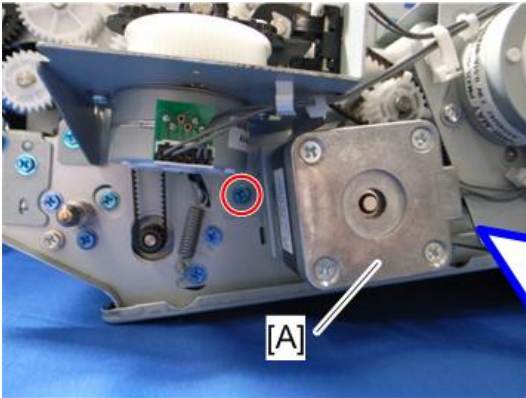

m022r638

- 2. Paper exit motor bracket [A] (⚙ x 2, 📡 x 1)

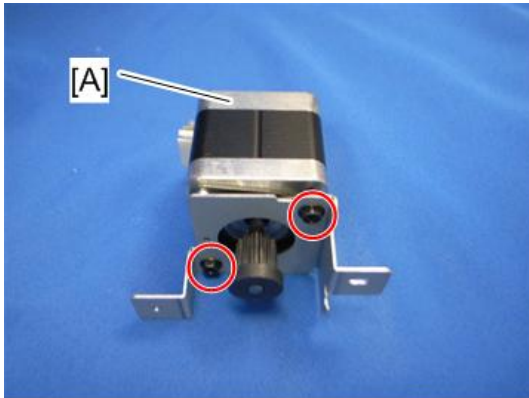

m022r639

3. Paper exit motor [A] (🔩 x 2)

4

Shift Roller Motor

1. Internal finisher (🔩 page 400)
2. Paper exit motor (🔩 page 404)

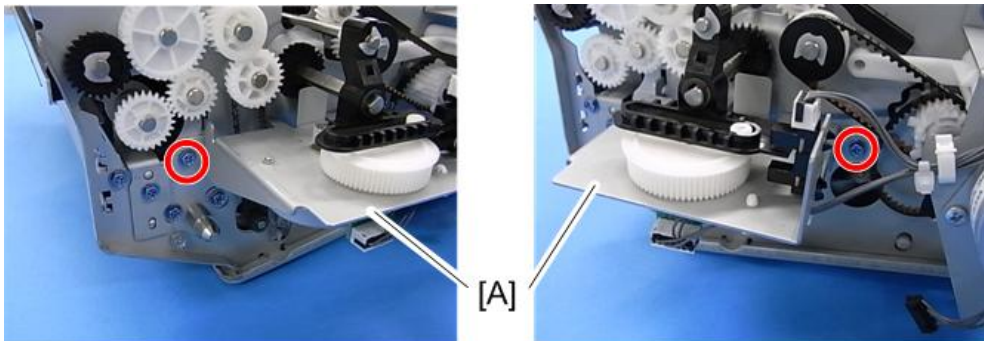

m022r790

3. Shift roller motor bracket [A] (🔩 x 2)

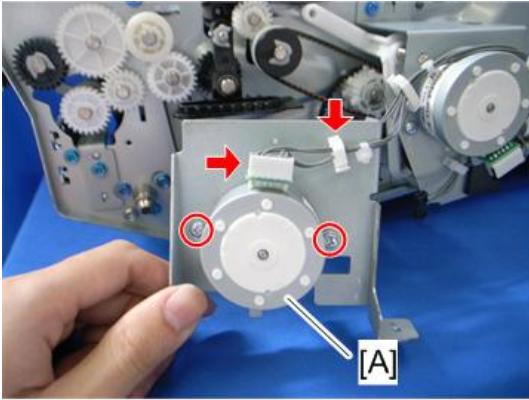

m022r640

4

- 4. Shift roller motor [A] (⚙️ x 2, 📡 x 1, 📡 x 1)

Transport Motor

- 1. Internal finisher (📖 page 400)

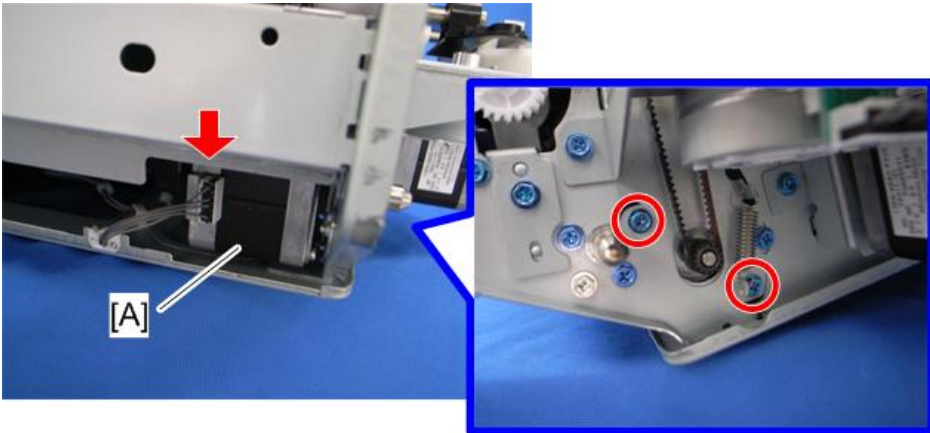

m022r641

- 2. Transport motor (⚙️ x 2, 📡 x 1)

Tray Lift Motor

- 1. Internal finisher (📖 page 400)
- 2. Output tray unit (📖 page 402)

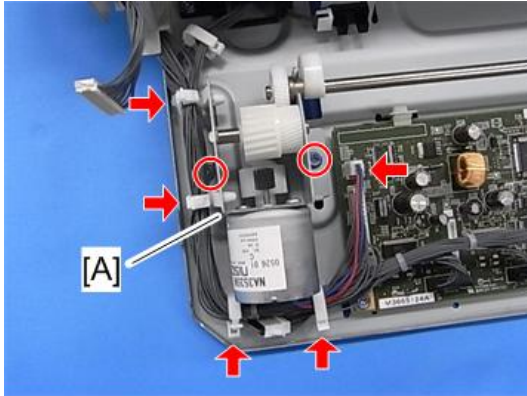

m022r793

3. Release the tray lift motor bracket [A] (🔩 x 2, 🛠 x 1, 🛠 x 4)

4

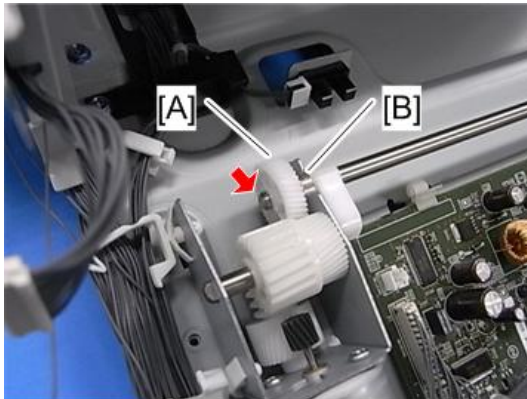

m022r794

4. Remove the gear [A] and bushing [B] (🔧 x 1).

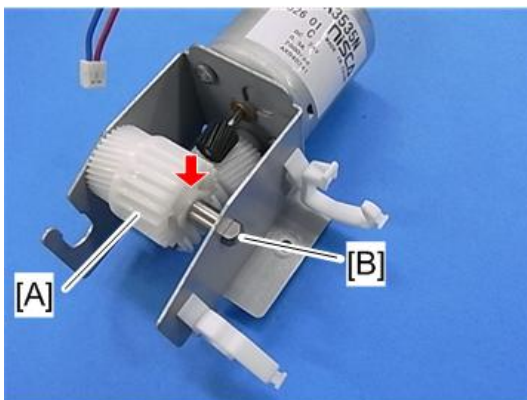

m022r795

5. Remove the gear [A] and shaft [B] (🔧 x 1).

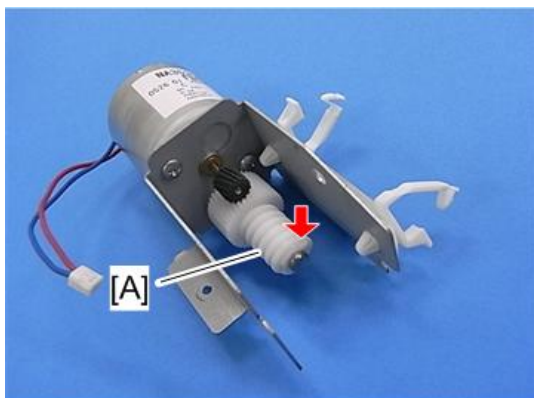

m022r796

4

6. Gear [A] (🔧 x 1)

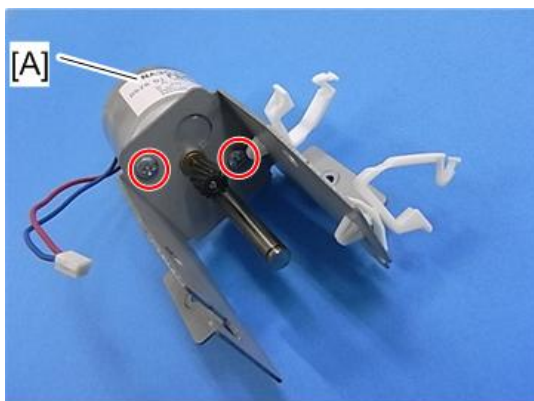

m022r797

7. Tray lift motor [A] (🔧 x 2)

Jogger Motor

1. Internal finisher (🔧 page 400)
2. Output tray unit (🔧 page 402)
3. Transport motor (🔧 page 406)

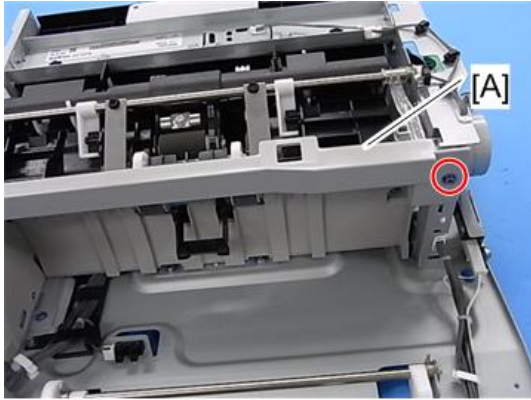

m022r806

4. Remove the cover [A] (🔩 x 1).

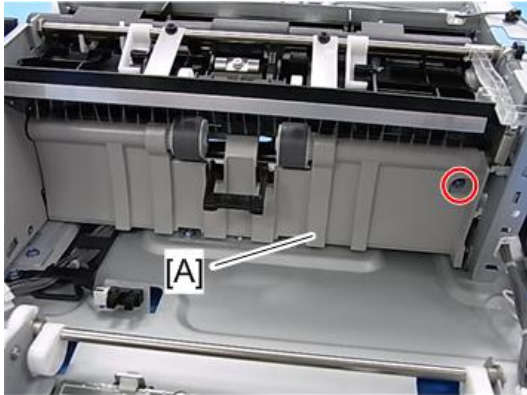

m022r807

5. Guide plate [A] (🔩 x 1).

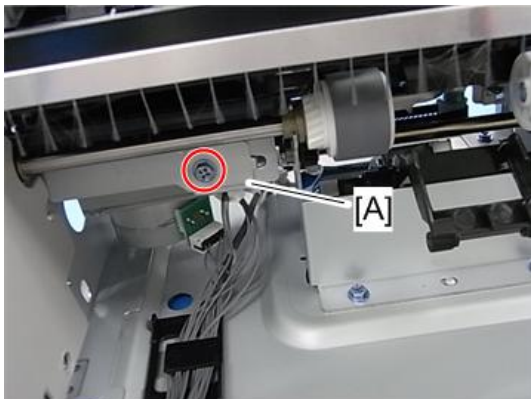

m022r808

6. Jogger fence HP sensor bracket [A] (🔩 x 1).

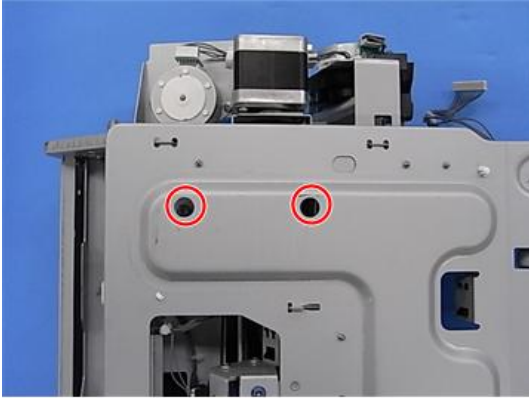

m022r810

4

7. Remove the two screws.

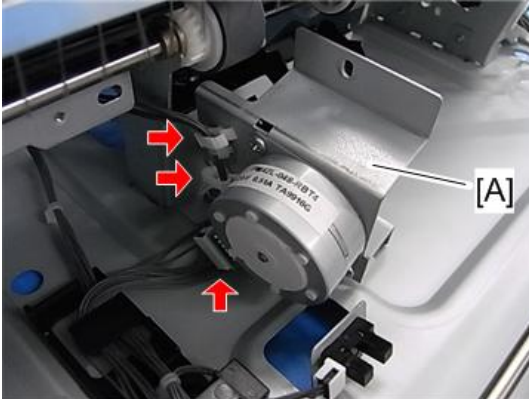

m022r812

8. Jogger motor bracket [A] (🔩 x 1, 🛠️ x 2)

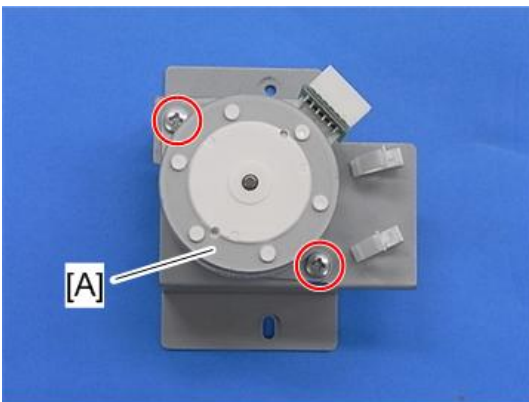

m022r813

9. Jogger motor [A] (🛠️ x 2)

Exit Guide Plate Motor

1. Inner right cover (☞ page 226)

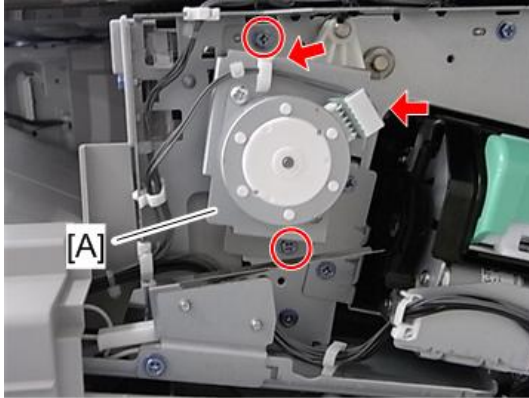

m022r814

2. Exit guide plate motor bracket [A] (☞ x 2, ☞ x 1, ☞ x 1)

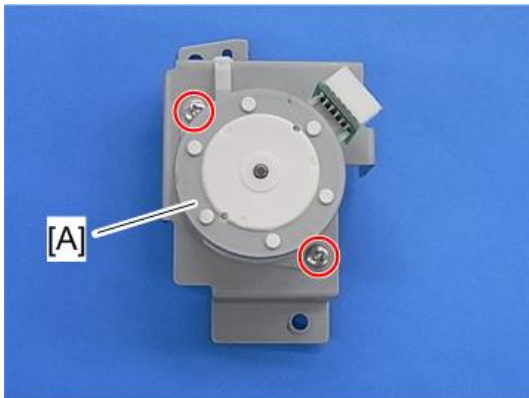

m022r815

3. Exit guide plate motor [A] (☞ x 2)

Shift Roller HP Sensor

1. Internal finisher (☞ page 400)

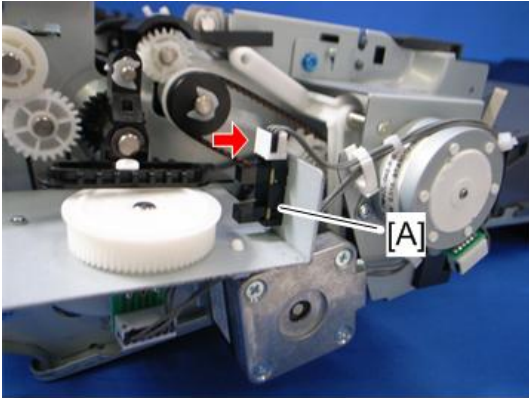

m022r642

4

2. Shift roller HP sensor [A] (🔧 x 1, hooks)

Gathering Roller HP Sensor

1. Internal finisher (🔧 page 400)

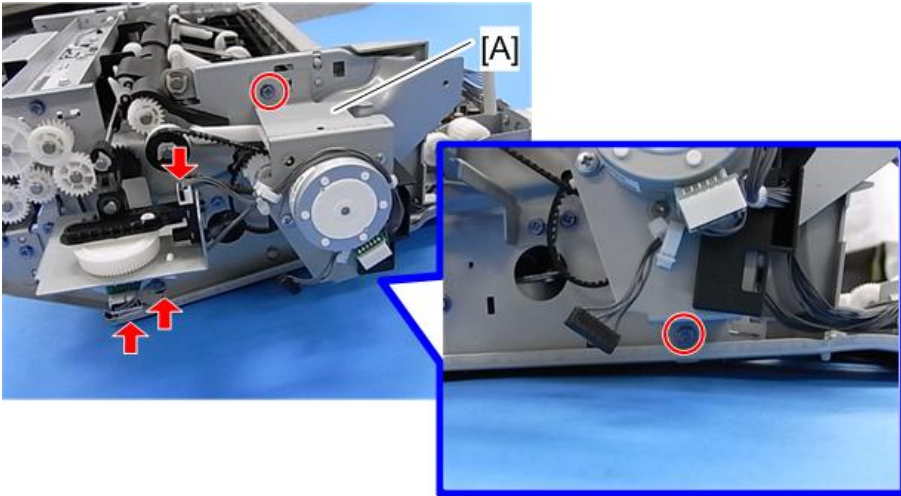

m022r804

2. Gathering roller motor bracket [A] (🔧 x 2, 📏 x 2, 📏 x 1)

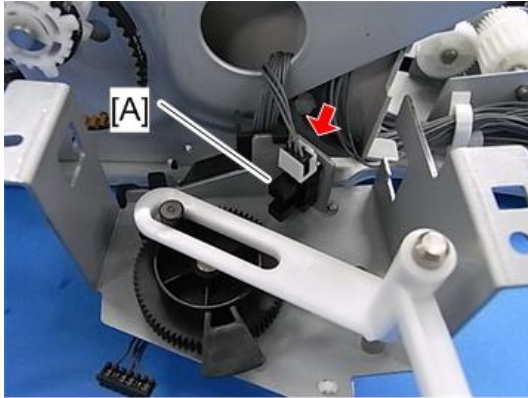

m022r805

3. Gathering roller HP sensor [A] (🔧 x 1, hooks)

4

Jogger Fence HP Sensor

1. Internal finisher (🔧 page 400)
2. Output tray unit (🔧 page 402)



m022r806

3. Remove the cover [A] (🔧 x 1).

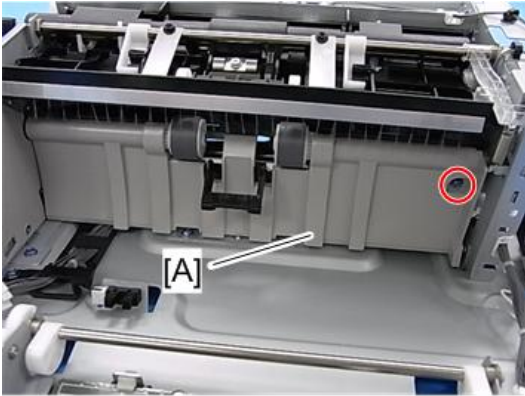

m022r807

4

4. Guide plate [A] (🔩 x 1).

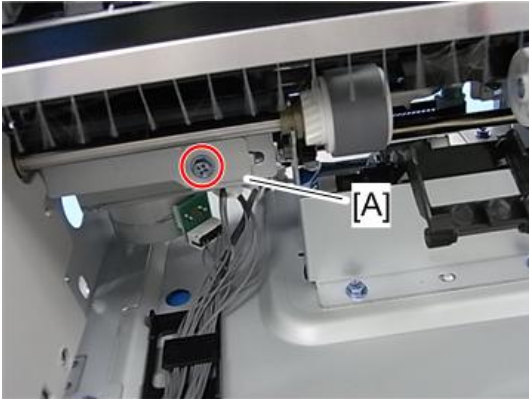

m022r808

5. Jogger fence HP sensor bracket [A] (🔩 x 1).

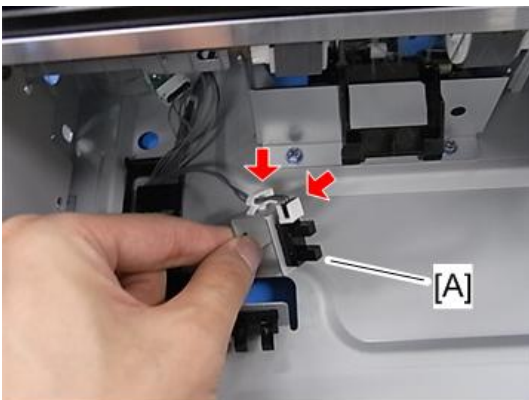

m022r809

6. Jogger fence HP sensor [A] (🔌 x 1, 📏 x 1, hooks)

Entrance Sensor

1. Internal finisher (📄 page 400)



m022r798

2. Entrance sensor bracket [A] (🔧 x 1)

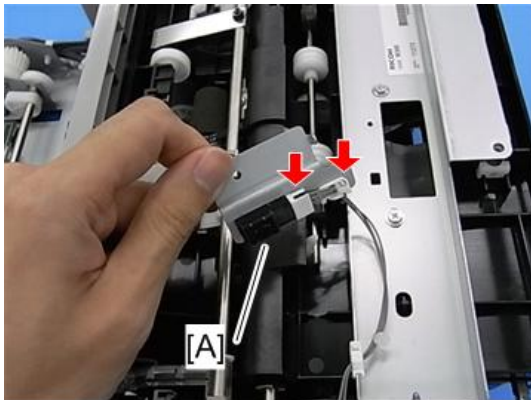

m022r799

3. Entrance sensor [A] (📄 x 1, 📄 x 1)

Paper Exit Sensor

1. Internal finisher (📄 page 400)
2. Output tray unit (📄 page 402)

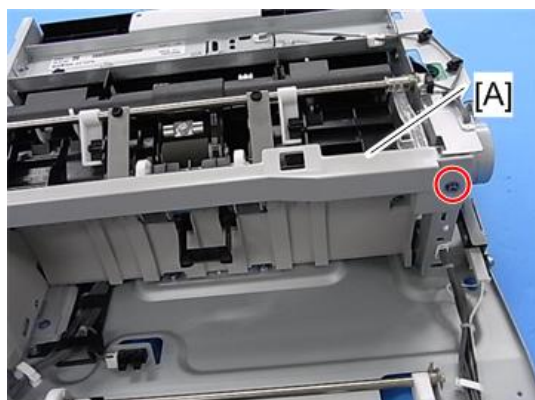

m022r806

4

3. Remove the cover [A] (🔩 x 1).

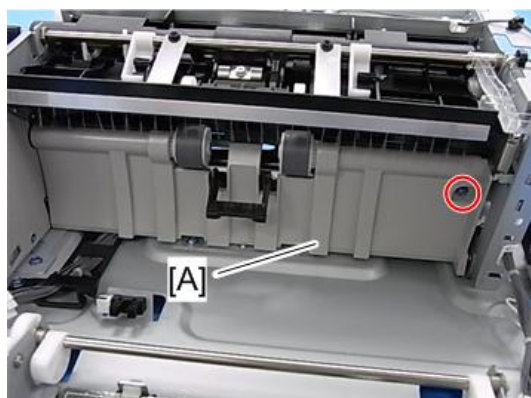

m022r807

4. Guide plate [A] (🔩 x 1)

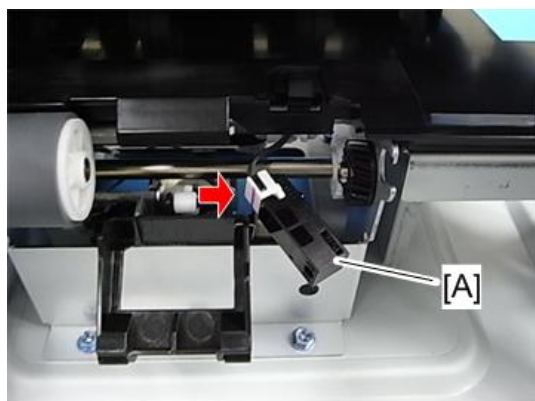

m022r896

5. Paper exit sensor [A] (🔩 x 1)

Paper Sensor

1. Internal finisher (📄 page 400)

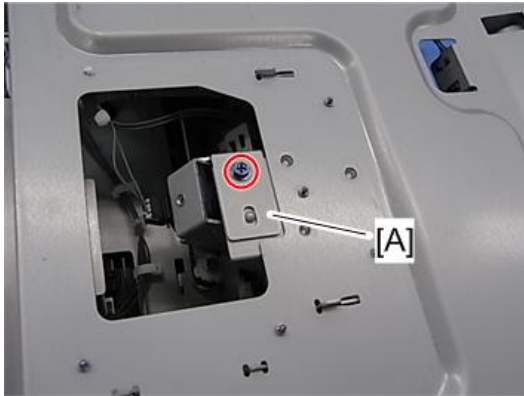

m022r800

2. Paper sensor bracket [A] (🔩 x 1)

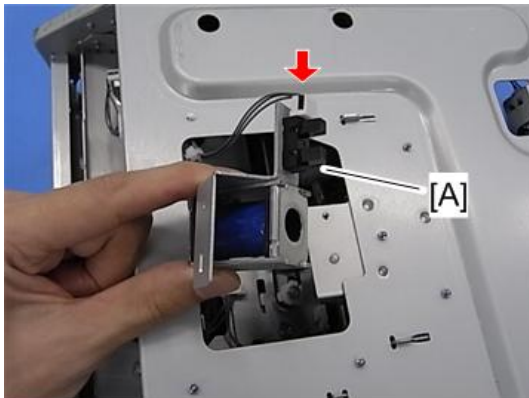

m022r801

3. Paper sensor [A] (📄 x 1, hooks)

Staple Tray Paper Sensor

1. Internal finisher (📄 page 400)

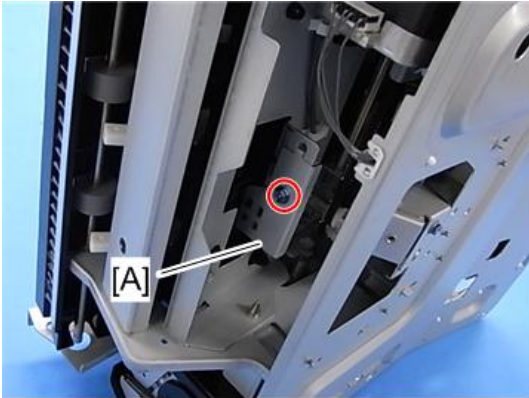

m022r802

4

2. Staple tray paper sensor bracket [A] (🔩 x 1)

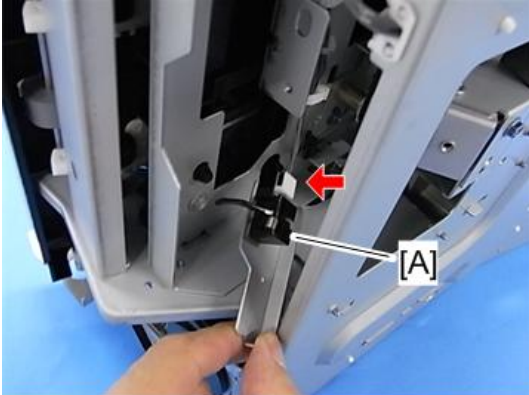

m022r803

3. Staple tray paper sensor [A] (📄 x 1, hooks)

Tray Lower Limit Sensor

1. Internal finisher (📄 page 400)
2. Output tray unit (📄 page 402)

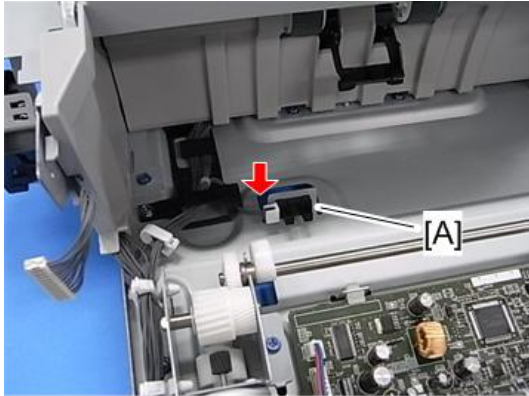

m022r792

3. Tray lower limit sensor [A] (🔧 x 1, hooks).

4

Main Board

1. Internal finisher (🔧 page 400)
2. Output tray unit (🔧 page 402)

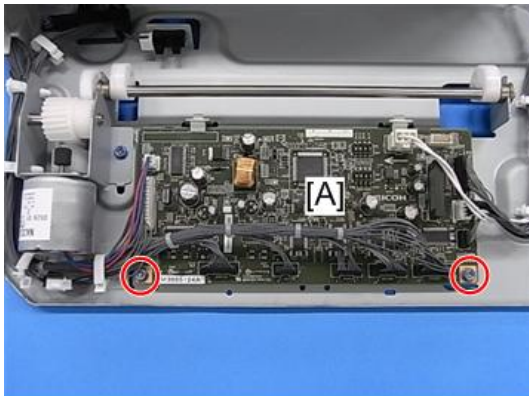

m022r791

3. Main board [A] (🔧 x 2, 🛠️ x all)

When reinstalling the main board



m022r791a

4

Check the DIP switch (SW100) [A] on the old main board. If the settings on the new main board are different from the old main board, change the settings on the new board (they must be the same as the settings on the old board).

Electrical Components

Boards

Rear Cover and Controller Cover Removal



d191b0046

No.	Item
①	IPU
②	Controller Board
③	HDD Unit
④	PSU

Left Cover Removal

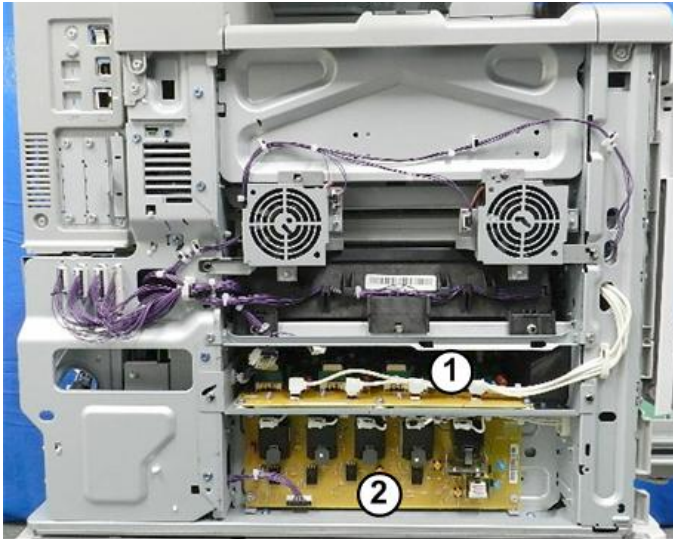

d191b0047

[D]	HVPS: CB Board
[E]	HVPS: T1T2 Board

PSU Box Open

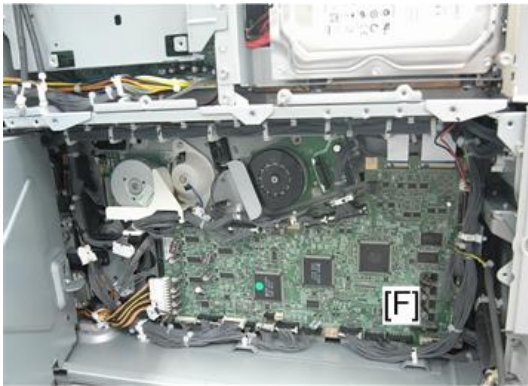

m022r745

[F]	BCU
-----	-----

Controller Box Cover

1. Rear cover (see page 213)

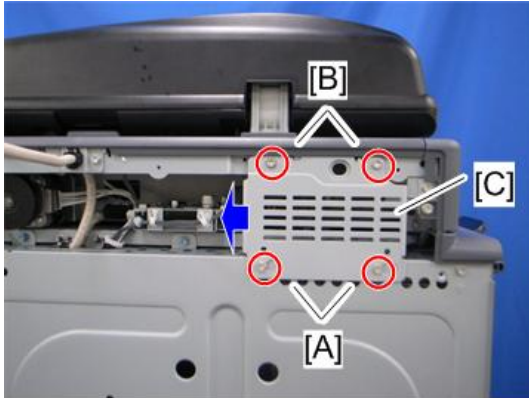

m022r506

2. Loosen two screws [A], and remove two screws [B].
3. Slide the scanner cable bracket [C] in the direction of the blue arrow, and then remove it.

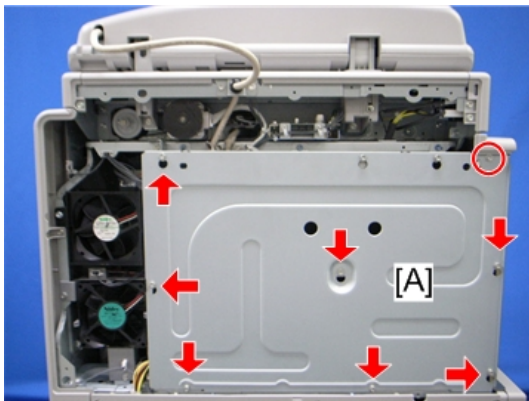

m022r507

4. Loosen seven screws, and remove one screw.
5. Slide up the controller box cover [A], and then remove it.

Controller Box

Note

- Remove the optional counter interface unit when opening or removing the controller box.

Opening the controller box

1. Rear cover (📄 page 213)
2. Rear lower cover (📄 page 212)
3. Controller box cover (📄 page 422)

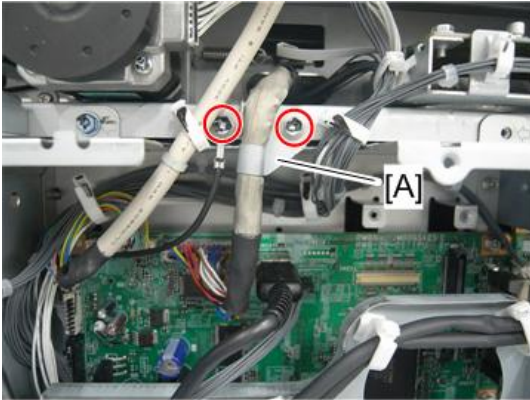

m022r607

4

4. Release the ground cable and the bracket [A] (⚙️ x 2).

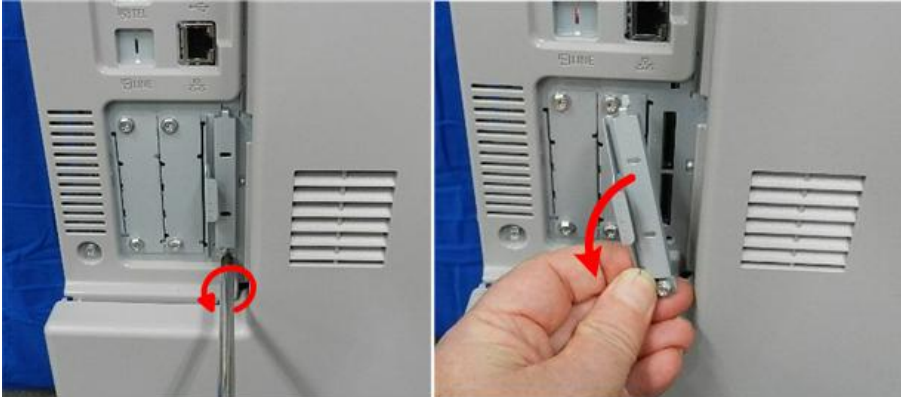

d191b0007

5. Remove the SD card slot cover (⚙️ x 1)
6. Disconnect all the harnesses (🔌 x All).

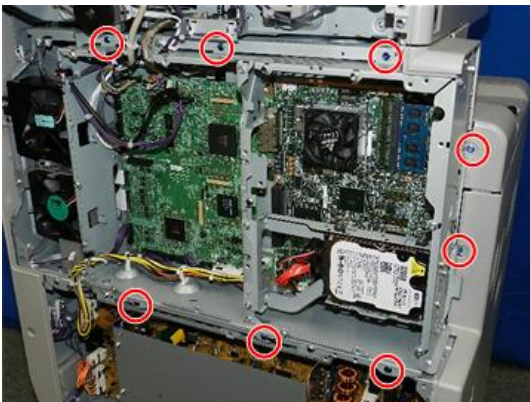

d191b0048

7. Remove screws (⚙️ x 8).

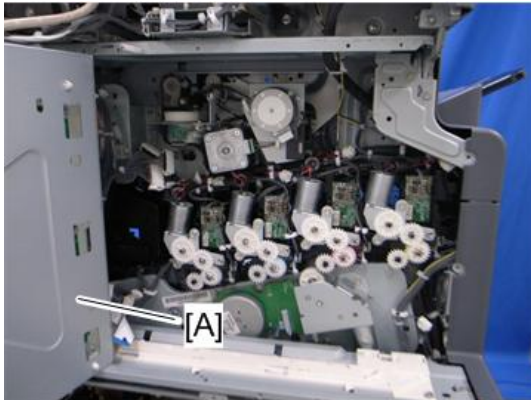

m022r610

8. Open the controller box [A].

4

Removing the controller box

1. Rear cover (🔧 page 213)
2. Rear lower cover (🔧 page 212)
3. Controller box cover (🔧 page 422)

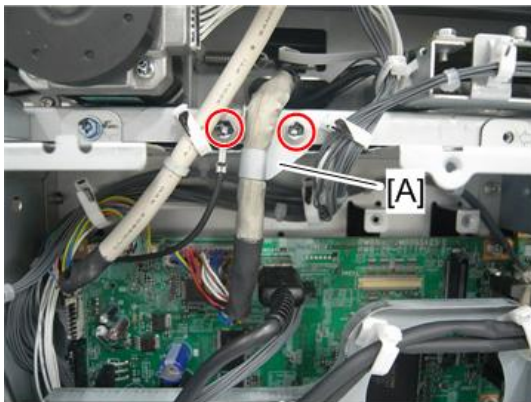

m022r607

4. Release the ground cable and the bracket [A] (🔧 x 2).
5. Disconnect all the harnesses (🔧 x All).

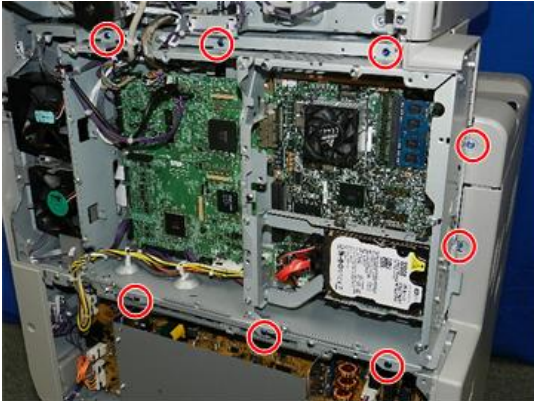

d191b0049

4

6. Remove screws (🔩 x8).

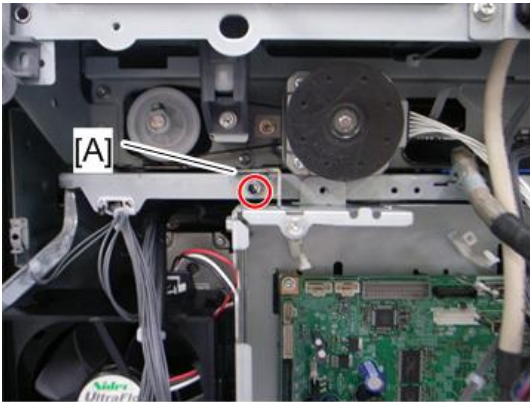

m022r609

7. Bracket [A] (🔩 x 1)

8. Remove the controller box.

HDD

1. Rear cover (🔩 page 213)
2. Controller box cover (🔩 page 422)



d191b0016

3. The single HDD unit is located at the left rear corner of the machine.

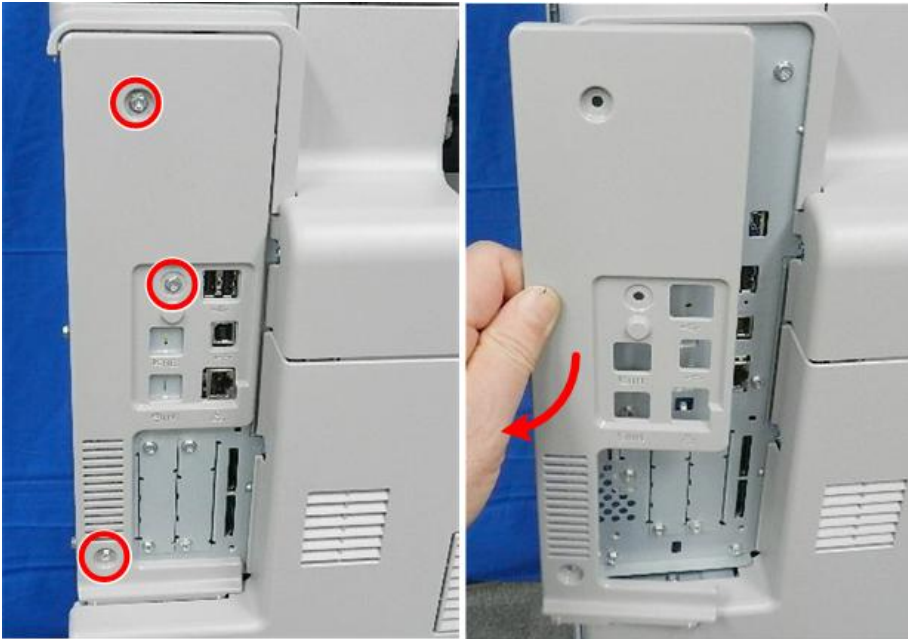

d191b0051

4. Remove the controller box faceplate (🔧x3).

4



d191b0017

5. Disconnect the edge of the HDD unit bracket (🔩 x2).



d191b0018

6. Disconnect the other edge of the bracket (🔩 x2).



d191b0019

7. Pull the bracket away slightly, disconnect the HDD unit, and then remove it (with HDD attached) (🔩 x2).

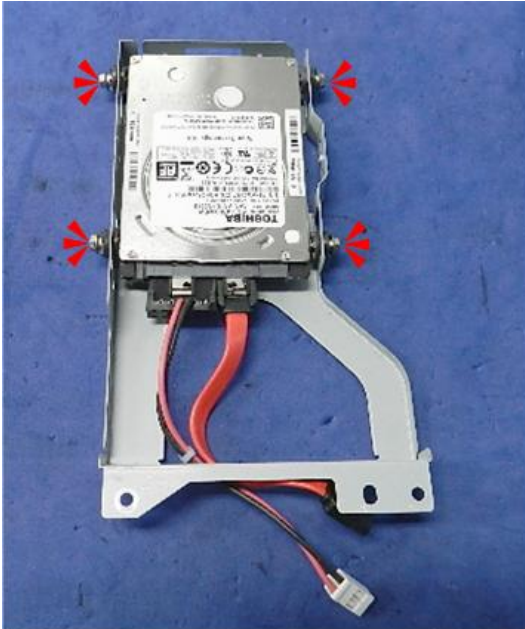

d191b0020

8. Disconnect the HDD (🔧 x4).



d191b0021

9. Separate the HDD from the bracket, and then disconnect the harnesses (🔧 x2).

When installing a new HDD unit

1. Turn the main power switch on. The disk is automatically formatted.
2. Install the stamp data using "SP5853".
3. Switch the machine off and on to enable the fixed stamps for use.

Disposal of HDD Units

- Never remove an HDD unit from the work site without the consent of the client.
- If the customer has any concerns about the security of any information on the HDD, the HDD must remain with the customer for disposal or safe keeping.
- The HDD may contain proprietary or classified (Confidential, Secret) information. Specifically, the HDD contains document server documents and data stored in temporary files created automatically during copy job sorting and jam recovery. Such data is stored on the HDD in a special format so it cannot normally be read but can be recovered with illegal methods.

Reinstallation

4

Explain to the customer that the following information stored on the HDD is lost when the HDD is replaced:

- Address book

The address book and document server documents (if needed) must be input again.

If you previously backed up the address book to an SD card with SP5846 051, you can use SP 5846 052 to copy the data from the SD card to the hard disk.

If the customer is using the following options, each option function must be set up again. For more, see each reference guide.

- Data Overwrite Security Unit: See "Security Guide".
- HDD Encryption Unit: See "Security Guide".
- ELP NX: See "Enhanced Locked Print NX Administrator's Guide".

Controller Board

1. Rear cover (📄 page 213)
2. Controller box cover (📄 page 422)
3. HDD assembly (📄 page 426)



d191b0050

4. Remove the SD card slot cover (⚙️ x1).

Note

- If there are any SD cards in Slots 1 or 2, or any boards in Slots A and B, remove them now.
- Be sure to disconnect any connected USB or network cables.

4

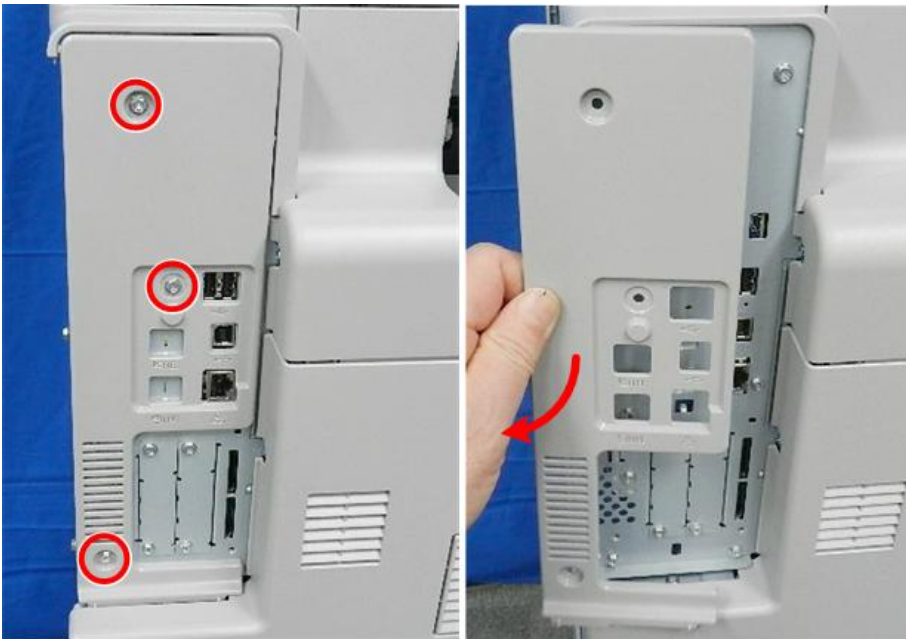

d191b0051

5. Remove the faceplate (⚙️ x3).



d191b0052

6. Disconnect the right edge of the controller plate ( x1).

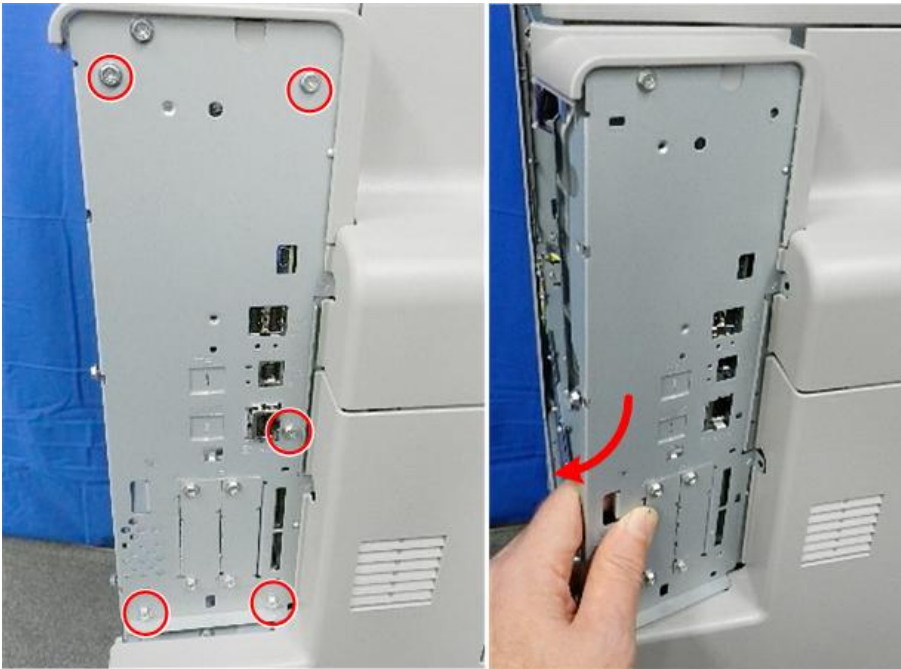

d191b0053

7. Disconnect the face of the controller box plate, and then remove it ( x5).

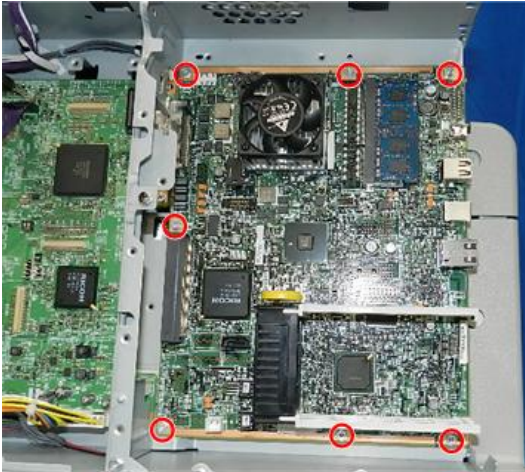

d191b0054

8. Disconnect the controller board (⚠x7).

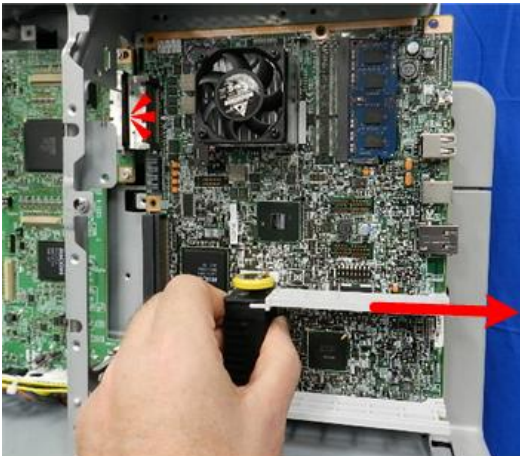

d191b0055

9. Slide the board to the right to disconnect it, and then remove it.

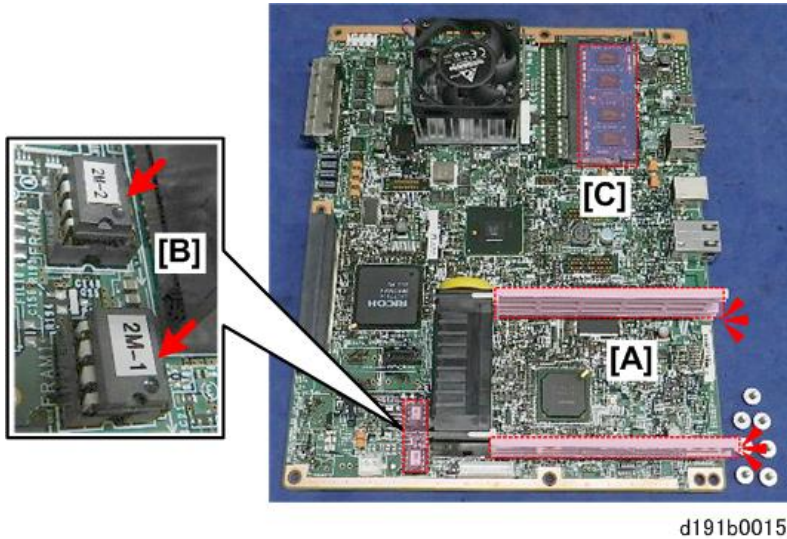

d191b0015

10. Before the controller board is replaced, the interface board rails [A], NVRAMs [B], and RAM-DIMMs [C] must be removed from the old board and installed on the new board.

Installing a New Controller Board

★ Important

- When replacing the controller board, first, check which ESA applications have been installed. After replacing the controller board, re-install the ESA applications by following the installation instructions for each application.
- After reinstalling the ESA applications, print the SMC (SP-5-990-024/025 (SMC: SDK/ Application Info)). Then open the tandem tray [A] and remove the paper cassette decal [B]. Store the SMC sheet [C] and the SD card(s) [D] that was used to install the ESA application(s).

1. Remove the NVRAM and RAM DIMMs from the old controller board.
2. Install the NVRAM and RAM DIMMs on the new controller board after you replace the controller board.

There are two NVRAM, labeled **2M-2**, and **2M-1**. These labels are used for a prototype model. The labels for the mass product models are different.

★ Important

- These NVRAMs are a set and must always be removed together and installed on a new board at the correction locations. Failure to do this will cause the machine to issue SC195-00.
- Keep NVRAMs away from any objects that can cause static electricity. Static electricity can damage NVRAM data.

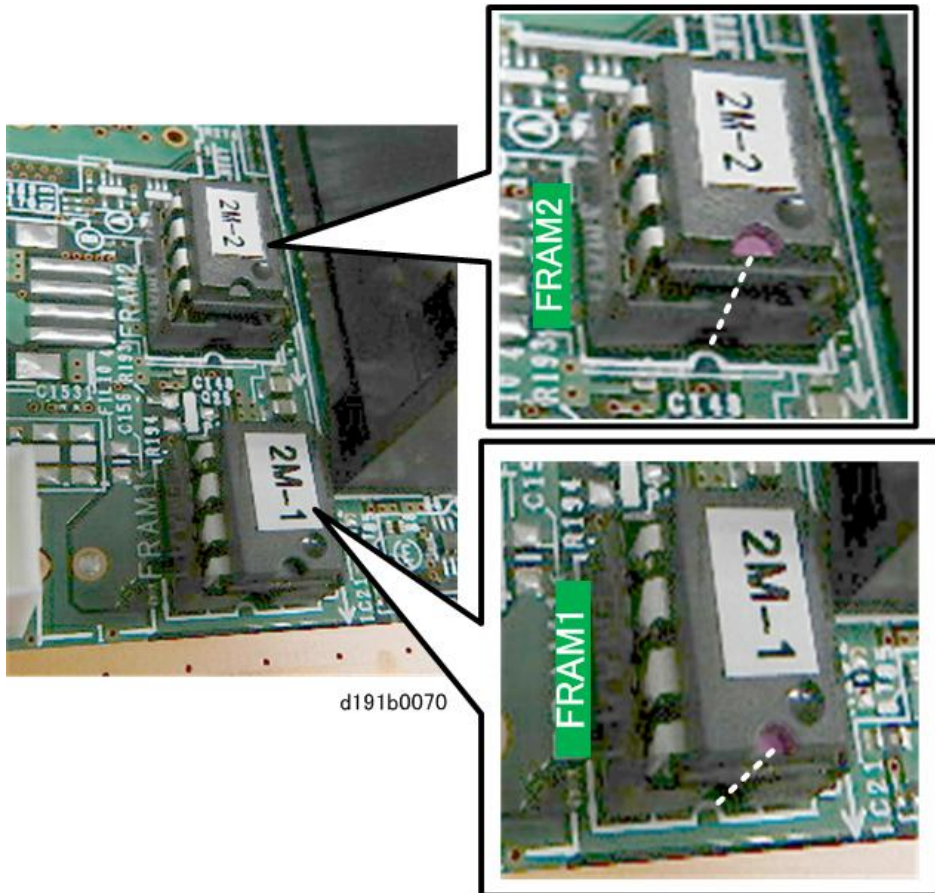

- 2M-2 is inserted into the connector labeled FRAM-2.
- 2M-1 is inserted into the connector labeled FRAM-1.
- The semi-circular notch of each NVRAM should be aligned with the white semi-circular notch below it as shown above at the dotted white lines.

⚠ CAUTION

- If the NVRAMs are installed incorrectly, this could cause the board and NVRAMs to short out and cause permanent damage.
1. Reassemble the machine.
 2. Turn on the main power of the machine.

↓ Note

- Make sure you print out the SMC reports ("SP Mode Data" and "Logging Data") before you replace the NVRAM.

BCU

1. Rear lower cover (see page 212)
2. PSU box (see page 443)

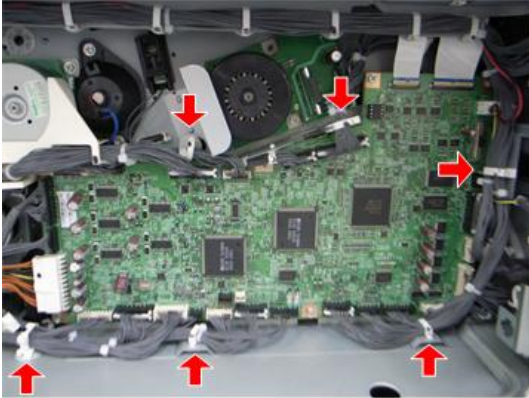

m022r611

3. Release the six connectors and disconnect all the harnesses.

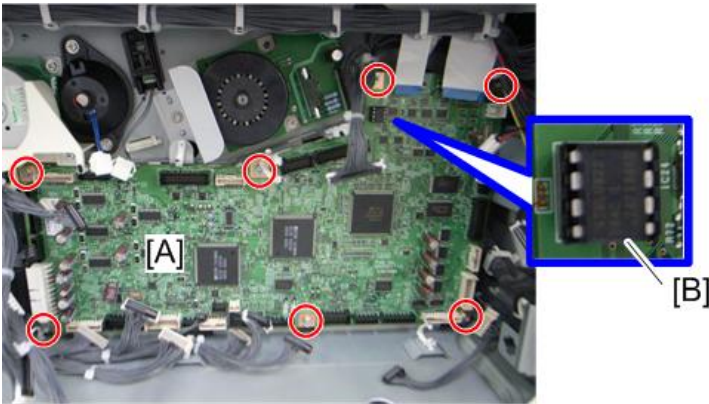

m022r612

4. BCU [A] (x 7)

Note

- Make sure the EEPROM is correctly installed on the BCU. Insert the EEPROM in the EEPROM slot with the "half-moon" pointing [B] to the downward side.

When installing the new BCU

1. Remove the EEPROM from the old BCU.
2. Install the EEPROM on the new BCU after you replace the BCU.
3. Reassemble the machine.

4. Turn on the main power of the machine.
5. "SC995-01" occurs.
6. Enter the serial number with SP5811-004.
7. Turn the main power of the machine off and on.

Note

- Make sure you print out the SMC reports ("SP Mode Data" and "Logging Data") before you replace the EEPROM.

CAUTION

- Keep EEPROM away from any objects that can cause static electricity. Static electricity can damage EEPROM data.

4

Removing the BCU with bracket

1. Rear lower cover (see page 212)
2. PSU box (see page 443)

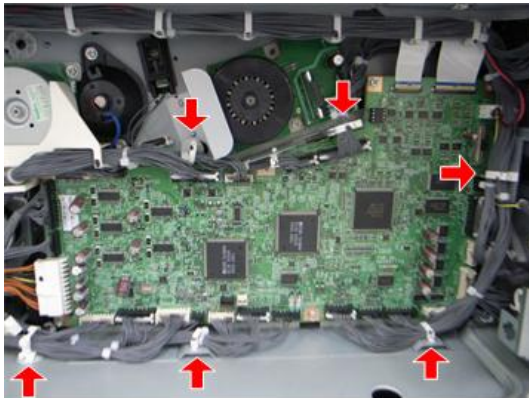

m022r611

3. Release the six clamps and disconnect all the harnesses.

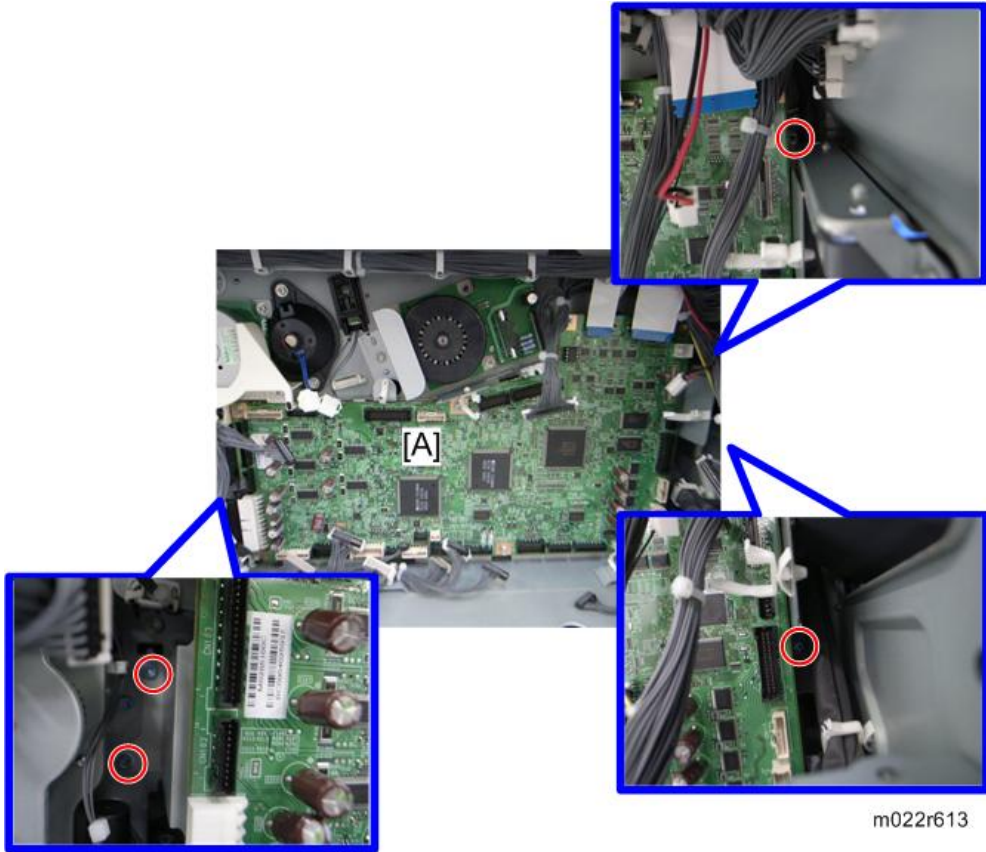

4. BCU with bracket [A] (🔧 x 4)

NVRAM/EEPROM Replacement Procedure

There are three NVRAMs. Two are on the controller board, and one is on the BCU.

★ Important

- Always touch a metal surface before handling an NVRAM. Static electricity from your hands can damage an NVRAM.

SMC Report

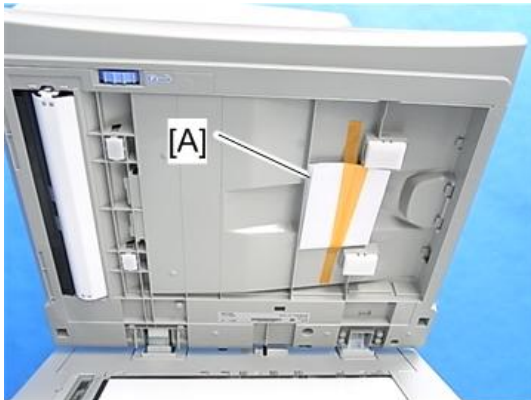

m022i136

Make sure the SMC report [A] is stored as shown above.

4

EEPROM on the BCU

1. Make sure that you have the SMC report (factory settings). This report comes with the machine.
2. Output the SMC data (SP5-990-001) if possible.
3. Turn the main switch off.
4. Install an SD card into SD card slot 2. Then turn the main power on.
5. Copy the EEPROM data to an SD card (SP5-824-001) if possible.
6. Turn off the main switch. Then unplug the power cord.
7. Replace the EEPROM on the BCU and reassemble the machine.
8. Plug in the power cord. Then turn the main switch on.
9. SC195 occurs.
10. Copy the data from the SD card to the EEPROM (SP5-825-001) if you have successfully copied them to the SD card.
11. Turn the main switch off. Then remove the SD card from SD card slot 2.
12. Turn the main switch on.
13. Specify the SP and UP mode settings.
14. Do the process control self-check.
15. Do ACC for the copier application program.
16. Do ACC for the printer application program.

NVRAM on the Controller

After Replacement of a Defective NVRAM

1. You will need the factory settings sheet provided with the machine.
2. Turn the power on, enter the SP mode, and then do the factory settings.
3. Re-install security settings as required.

NVRAM Upload and Download

1. Make sure that you have the SMC report (factory settings). This report comes with the machine.
2. Output the SMC data ("ALL") using SP5-990-001.
3. Turn off the main switch.
4. Insert a blank SD card into Slot 2, and then turn on the machine.
5. Upload the NVRAM data to the blank SD card using SP5-824-001 (NVRAM Data Upload).
6. The settings of the following SP codes cannot be copied. Enter the SP mode, make a note of their settings, and then re-enter them manually after the NVRAM has been replaced:
 - SP5985-001. Enable onboard NIC.
 - SP5985-002. Enable onboard USB.
7. Turn off the main power switch, and then unplug the AC power cord.
8. Remove the SD card from slot #2.
9. Replace the NVRAM on the controller board with a new one, plug in the AC power cord, and then turn on the main power switch.
10. Do SP5846-051 to copy all address data to the SD card.
11. Turn the machine off, and then unplug it.
12. Remove the SD card with the address book data from Slot 2.
13. Swap the old NVRAMs on the controller board with new ones.

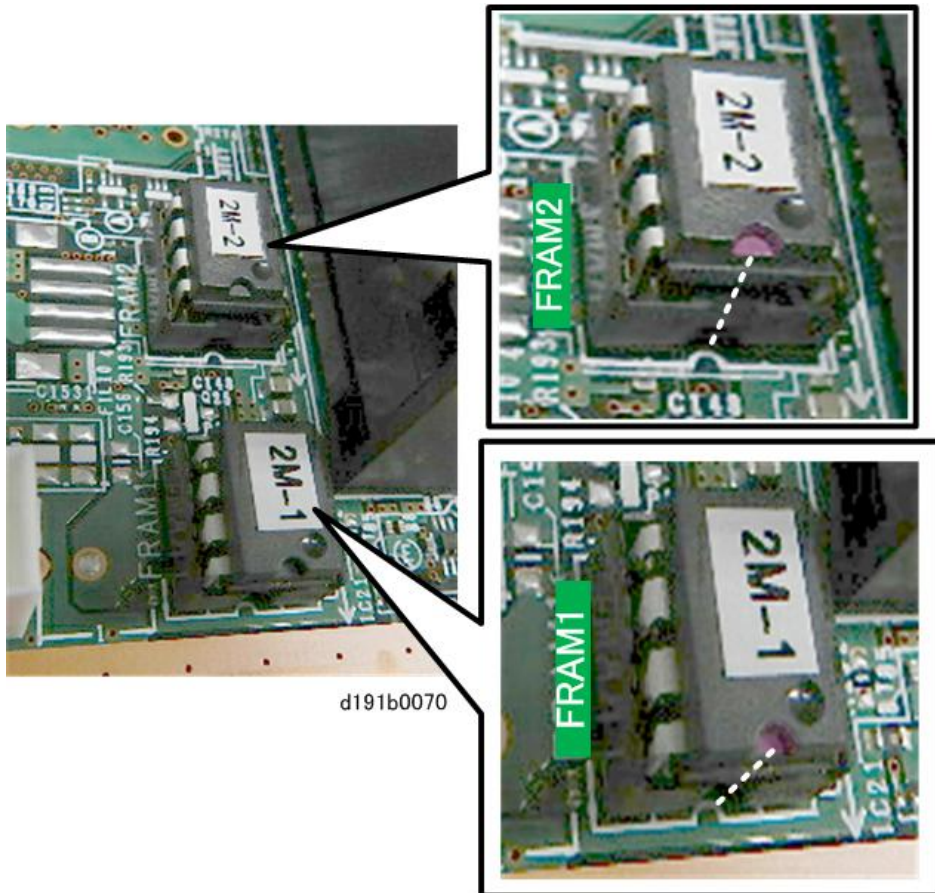

d191b0070

4

Two NVRAMs are on the controller board.

- These NVRAMs are a set. When replacing the controller board, remove both NVRAMs, 2M-1 and 2M-2, and then attach them to the new board at the same locations. Failure to do this will cause the machine to issue SC195-00.
 - NVRAM 2M-1 is inserted at connector socket labeled FRAM-1. Make sure that the circular notch on the NVRAM is pointing in the direction of arrow embossed on the board.
 - NVRAM 2M-2 is inserted at connector socket. Make sure that the circular notch on the NVRAM is pointing in the direction of the arrow embossed on the board.
 - If the NVRAMs are installed incorrectly, this could cause both the board and the NVRAMs to short out and cause permanent damage.
 - After the board is determined whether the ESA application should be installed, and then follow the procedure to install each application.
1. Make sure that there is no SD card in Slot 2, and then plug in the power cord and turn the machine on.

★ Important

- **If the machine returns SC995-02, cycle the machine off and try again.**
2. Insert the SD card with the copied NVRAM data in Slot 2.
 3. Do SP5825-001 to download the data from the SD card. This requires two or three minutes to complete.
 - When you see the “Finished!” message, cycle the machine off/on, and then touch [Exit]. Do not turn the machine off.
 - If SC870-11 (Address Book Data Error) appears, ignore it.
 4. Enter the SP mode and manually enter the settings for the SP codes that you recorded in Step 5:
 - SP5985-001. Enable onboard NIC.
 - SP5985-002. Enable onboard USB.

↓ Note

- After doing a setting if the machine prompts you to cycle the machine off/on, ignore this message and continue until all the settings are done.
5. Turn the machine off and remove the SD card from Slot 2.
 6. Turn the machine on.
 7. Insert the SD card with the address book data into Slot 2.
 8. Do SP5846-052 to restore the address book data.
 - The execution will fail if the settings at Step 16 for SP5985-001 or SP985-002 were not done correctly.
 - If this execution succeeds, the machine will prompt you to cycle the machine off/on.
 9. Switch the machine off, and then remove the SD card from Slot 2.
 10. Turn the machine on.
 11. Enter the SP mode and print another SMC report with SP5990-001, and then compare it with the original SMC report in Step 1 and correct any settings.

↓ Note

- Reset the NVRAM counter (all counters to zero).
12. Execute process control.

↓ Note

- If you see the message “SD Card for Restoration is Required”, the data encryption key must be re-installed.
13. Do ACC for the copier application program.
 14. Do ACC for the printer application program.

IPU

1. Rear cover (see page 213)
2. Controller box cover (see page 422)

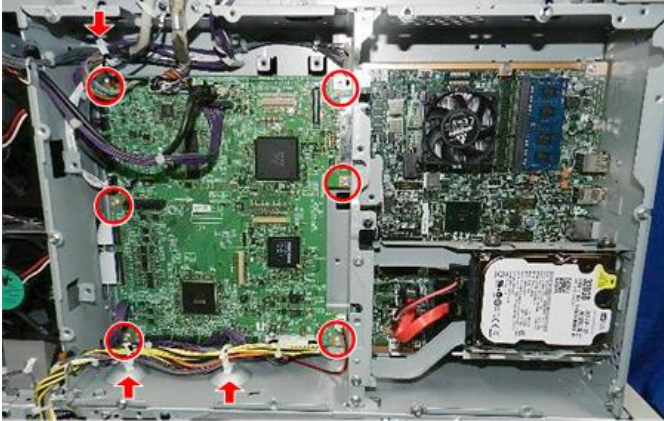

d191b0056

3. IPU [A] (🔩 x 6, 🛠️ x 3, 🛠️ x all)

PSU Box

Opening the PSU box

1. Rear lower cover (see page 212)



d191b0057

2. Connector bracket [A] (🔩 x 2)

4



d191b0058

3. Raise the bracket to disengage its metal hook, and then pull it to the left to remove it.

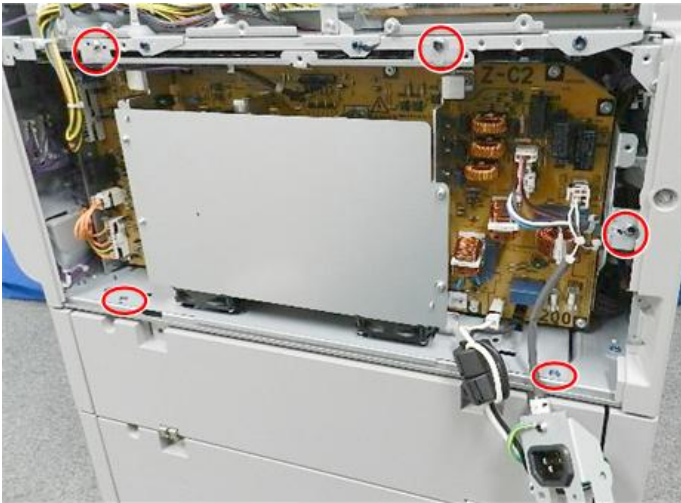

d191b0059

4. Open the PSU box (🔧 x 5, 📏 x All, 📏 x All).

Removing the PSU box

1. Rear lower cover (📏 page 212)

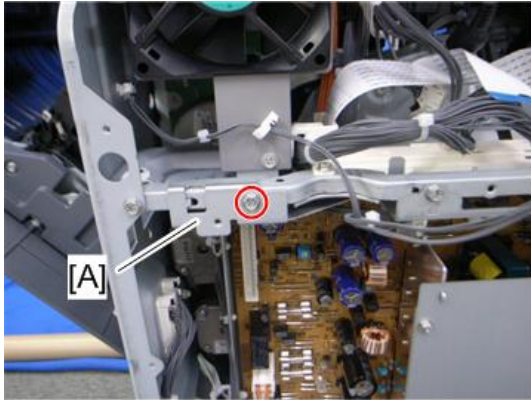

m022r614

2. Bracket [A] (🔩 x 1)

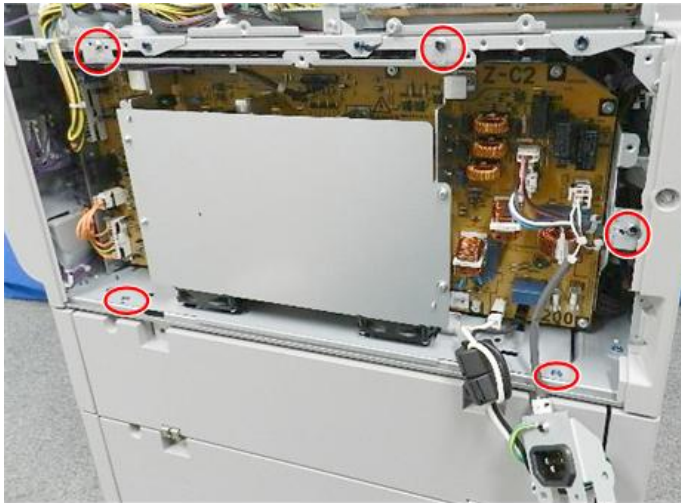

d191b0059

3. PSU box [A] (🔩 x 5, 📁 x All, 📁 x All)

RTB 54

Some areas of the PSU retain charge a long time after disconnecting the power. See the RTB for a diagram of these areas.

PSU

1. Rear lower cover (📁 page 212)
2. Connector bracket (📁 page 443)
3. Disconnect all the harnesses (📁 x All).

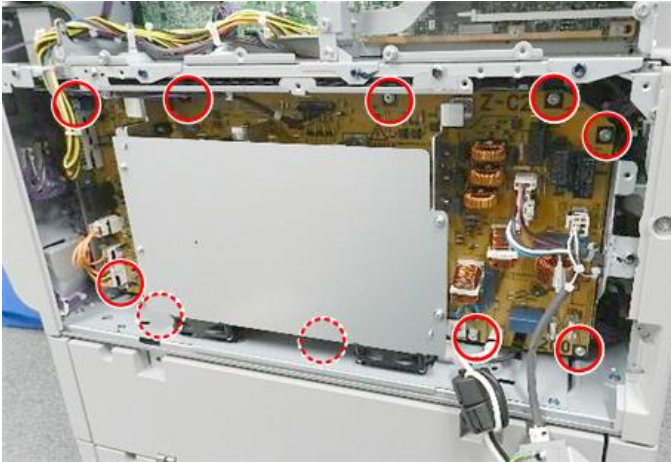

d191b0062

RTB 54
Some areas of the PSU retain charge a long time after disconnecting the power. See the RTB for a diagram of these areas.

4. PSU board (🔩 x 10, 🛠️ x all)

HVPS: T1T2 Board

1. Left cover (🛠️ page 211)

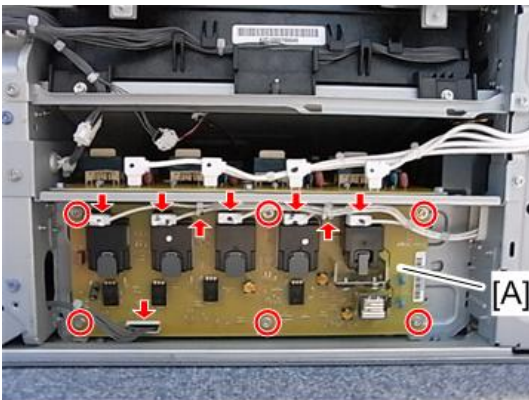

m022r645

2. HVPS: T1T2 board [A] (🔩 x 6, 🛠️ x 6, 🛠️ x 2)

HVPS: CB Board

1. Left cover (🛠️ page 211)
2. Toner collection bottle (🛠️ page 210)



3. Remove the connector cover [A], and then disconnect the connector [B].

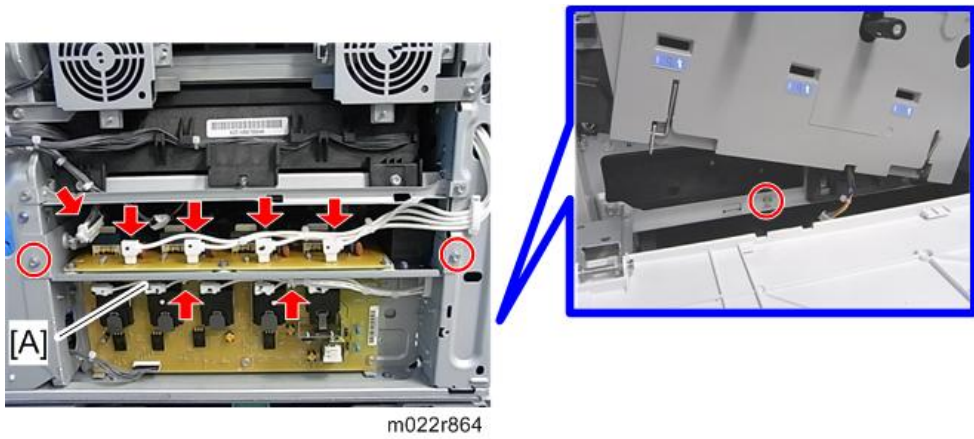

4. Board bracket [A] (🔩 x 3, 🛠️ x 5, 🛠️ x 2)

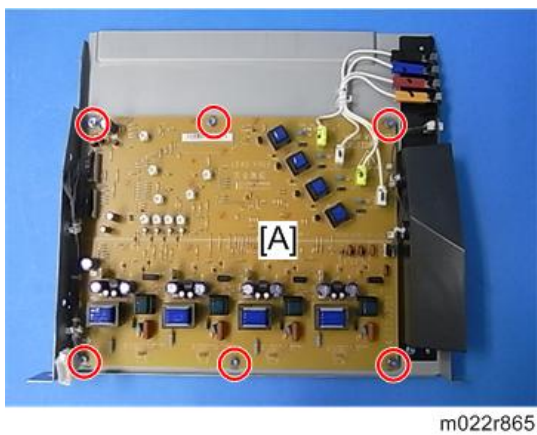

5. HVPS: CB board [A] (🔩 x 6, All 🛠️s)

4

5. System Maintenance

Service Program Mode

CAUTION

- Make sure that the data-in LED (🔌) is not on before you go into the SP mode. This LED indicates that some data is coming to the machine. When the LED is on, wait for the copier to process the data.

SP Tables

See "Appendices" for the following information:

- System Service Mode
- Printer Service Mode
- Scanner Service Mode

5

Enabling and Disabling Service Program Mode

Note

- The Service Program Mode is for use by service representatives only. If this mode is used by anyone other than service representatives for any reason, data might be deleted or settings might be changed. In such case, product quality cannot be guaranteed any more.

Entering SP Mode

For details, ask your supervisor.

Exiting SP Mode

- Press "Exit" on the LCD twice to return to the copy window.

Types of SP Modes



- System SP: SP modes related to the engine functions
- Printer SP: SP modes related to the controller functions
- Scanner SP: SP modes related to the scanner functions

- Fax SP: SP modes related to the fax functions

Select one of the Service Program modes (System, Printer, Scanner, or Fax) from the touch panel as shown in the diagram below after you access the SP mode. This section explains the functions of the System/Printer/Scanner SP modes. Refer to the Fax service manual for the Fax SP modes.

SP Mode Button Summary

Here is a short summary of the touch-panel buttons.

1	Opens all SP groups and sublevels.
2	Closes all open groups and sublevels and restores the initial SP mode display.
3	Opens the copy window (copy mode) so you can make test copies. Press SP Mode (highlighted) in the copy window to return to the SP mode screen,
4	Enter the SP code directly with the number keys if you know the SP number. Then press  . (The required SP Mode number will be highlighted when pressing  . If not, just press the required SP Mode number.)
5	Press two times to leave the SP mode and return to the copy window to resume normal operation.
6	Press any Class 1 number to open a list of Class 2 SP modes.
7	Press to scroll the show to the previous or next group.
8	Press to scroll to the previous or next display in segments the size of the screen display (page).
9	Press to scroll the show the previous or next line (line by line).
10	Press to move the highlight on the left to the previous or next selection in the list.

Switching Between SP Mode and Copy Mode for Test Printing



1. In the SP mode, select the test print. Then press "Copy Window".
2. Use the copy window (copier mode), to select the appropriate settings (paper size, etc.) for the test print.
3. Press Start  to start the test print.
4. Press SP Mode (highlighted) to return to the SP mode screen and repeat from step 1.

Selecting the Program Number

Program numbers have two or three levels.

1. Refer to the Service Tables to find the SP that you want to adjust before you begin.
2. Press the Group number on the left side SP Mode window that contains the SP that you want to adjust.
3. Use the scrolling buttons in the center of the SP mode window to show the SP number that you want to open. Then press that number to expand the list.
4. Use the center touch-panel buttons to scroll to the number and title of the item that you want to set and press it. The small entry box on the right activates and shows the below default or the current settings.

Note

- Refer to the Service Tables for the range of allowed settings.
5. Do this procedure to enter a setting:
 - Press  to toggle between plus and minus and use the keypad to enter the appropriate number. The number you enter writes over the previous setting.
 - Press  to enter the setting. (The value is not registered if you enter a number that is out of range.)
 - Press "Yes" when you are prompted to complete the selection.
 6. If you need to perform a test print, press Copy Window to open the copy window and select the settings for the test print. Press Start  and then press SP Mode (highlighted) in the copy window to return to the SP mode display.
 7. Press Exit two times to return to the copy window when you are finished.

Exiting Service Mode

- Press the Exit key on the touch-panel.

Service Mode Lock/Unlock

At locations where the machine contains sensitive data, the customer engineer cannot operate the machine until the Administrator turns the service mode lock off. This function makes sure that work on the machine is always done with the permission of the Administrator.

1. If you cannot go into the SP mode, ask the Administrator to log in with the User Tool and then set "Service Mode Lock" to OFF after he or she logs in:

User Tools > System Settings > Administrator Tools > Service Mode Lock > OFF

 - This unlocks the machine and lets you get access to all the SP codes.
 - The CE can service the machine and turn the machine off and on. It is not necessary to ask the Administrator to log in again each time the machine is turned on.
2. Go into the SP mode and set SP5169 to "1" if you must use the printer bit switches.

3. After machine servicing is completed:

- Change SP5169 from "1" to "0".
- Turn the machine off and on. Tell the administrator that you have completed servicing the machine.
- The Administrator will then set the "Service Mode Lock" to ON.

Remarks

Display on the Control Panel Screen

The maximum number of characters which can show on the control panel screen is limited to 30 characters. For this reason, some of the SP modes shown on the screen need to be abbreviated. The following are abbreviations used for the SP modes for which the full description is over 20 characters.

5

Paper Weight

Thin paper: 52-59 g/m²

Plain Paper: 60-90 g/m², 16-24lb.

Middle Thick: 91-105 g/m², 24-28lb.

Thick Paper 1: 106-169 g/m², 28.5-44.9lb.

Thick Paper 2: 170-220 g/m², 45-58lb.

Thick Paper 3: 221-256 g/m², 59lb-68lb

Thick Paper 4: 257 -300 g/m², 68.4-79.8lb

Paper Type

N: Normal paper

MTH: Middle thick paper

TH: Thick paper

Paper Feed Station

P: Paper tray

B: By-pass table

Color Mode [Color]

[K]: Black in B&W mode

[Y], [M], or [C]: Yellow, Magenta, or Cyan in Full Color mode

[YMC]: Only for Yellow, Magenta, and Cyan

[FC]: Full Color mode

[FC, K], [FC, Y], [FC, M], or [FC, C]: Black, Yellow, Magenta, or Cyan in full color mode

<p>Print Mode</p> <p>S: Simplex</p> <p>D: Duplex</p>	<p>Process Speed</p> <p>L: Low speed (85 mm/s)</p> <p>M: Middle speed (182 mm/s)</p> <p>H: Middle speed (260 mm/s)</p>
---	---

Others

The following symbols are used in the SP mode tables.

FA: Factory setting

(Data may be adjusted from the default setting at the factory. Refer to the factory setting sheets enclosed. You can find it under the jammed paper removal decal.)

DFU: Design/Factory Use only

Do not touch these SP modes in the field.

A sharp (#) to the right hand side of the mode number column means that the main switch must be turned off and on to effect the setting change.

An asterisk (*) to the right hand side of the mode number column means that this mode is stored in the NVRAM and EEPROM. If you do a RAM clear, this SP mode will be reset to the default value. "ENG" and "CTL" show which NVRAM contains the data.

- ENG: EEPROM on the BCU board
- CTL: NVRAM on the controller board

The settings of each SP mode are explained in the right-hand column of the SP table in the following way.

[Adjustable range / **Default setting** / Step] Alphanumeric

Note

- If "Alphanumeric" is written to the right of the bracket as shown above, the setting of the SP mode shows on the screen using alphanumeric characters instead of only numbers. However, the settings in the bracket in the SP mode table are explained by using only the numbers.

SSP: This denotes a "Special Service Program" mode setting.

System SP1-xxx: 1

SP1-XXX (Feed)

1001	[Leading Edge Registration] Leading Edge Registration Adjustment (Tray Location, Paper Type, Color Mode), Paper Type -> Plain, Thick 1, Thick 2 or Thick3		
	Adjusts the leading edge registration by changing the registration motor operation timing for each mode. Increasing a value: an image is moved to the trailing edge of paper. Decreasing a value: an image is moved to the leading edge of paper.		
001	Tray:Plain	*ENG	[-9 to 9 / 3.9 / 0.1 mm/step]
002	Tray:Middle Thick	*ENG	[-9 to 9 / -0.4 / 0.1 mm/step]
003	Tray:Thick1	*ENG	[-9 to 9 / -2.5 / 0.1 mm/step]
004	Tray:Thick2	*ENG	[-9 to 9 / -3.7 / 0.1 mm/step]
005	Tray:Thick3	*ENG	[-9 to 9 / -3.5 / 0.1 mm/step]
006	Tray:Plain:1200dpi	*ENG	[-9 to 9 / 0.8 / 0.1 mm/step]
007	Tray: Middle Thick:1200dpi	*ENG	[-9 to 9 / -0.5 / 0.1 mm/step]
008	Tray:Thick1:1200dpi	*ENG	[-9 to 9 / -0.5 / 0.1 mm/step]
009	By-pass:Plain	*ENG	[-9 to 9 / 3.9 / 0.1 mm/step]
010	By-pass: Middle Thick	*ENG	[-9 to 9 / 0.1 / 0.1 mm/step]
011	By-pass: Thick1	*ENG	[-9 to 9 / -1.8 / 0.1 mm/step]
012	By-pass: Thick2	*ENG	[-9 to 9 / -2.7 / 0.1 mm/step]
013	By-pass: Thick3	*ENG	[-9 to 9 / -2.4 / 0.1 mm/step]
014	By-pass:Plain:1200dpi	*ENG	[-9 to 9 / 0.8 / 0.1 mm/step]
015	By-pass: Middle Thick:1200dpi	*ENG	[-9 to 9 / 0.1 / 0.1 mm/step]
016	By-pass:Thick1:1200dpi	*ENG	[-9 to 9 / 0.1 / 0.1 mm/step]
017	Duplex:Plain	*ENG	[-9 to 9 / 3.9 / 0.1 mm/step]

018	Duplex: Middle Thick	*ENG	[-9 to 9 / -0.1 / 0.1 mm/step]
019	Duplex:Thick1	*ENG	[-9 to 9 / -2.1 / 0.1 mm/step]
020	Duplex: Thick2	*ENG	[-9 to 9 / -3 / 0.1 mm/step]
021	Duplex:Plain:1200dpi	*ENG	[-9 to 9 / 0.7 / 0.1 mm/step]
022	Duplex: Middle Thck:1200dpi	*ENG	[-9 to 9 / 0.1 / 0.1 mm/step]
023	Duplex:Thck1:1200dpi	*ENG	[-9 to 9 / 0 / 0.1 mm/step]
024	Tray:Thin	*ENG	[-9 to 9 / 1 / 0.1 mm/step]
026	By-pass:Thin	*ENG	[-9 to 9 / 1 / 0.1 mm/step]

1002	[Side-to-Side Registration]		
	Adjusts the side-to-side registration by changing the laser main scan start position for each mode and tray. Increasing a value: an image is moved to the rear edge of paper. Decreasing a value: an image is moved to the front edge of paper.		
	001	By-pass Table	*ENG
	002	Paper Tray 1	*ENG
	003	Paper Tray 2	*ENG
	004	Paper Tray 3	*ENG
	005	Paper Tray 4	*ENG
006	Duplex	*ENG	[-4 to 4 / 0.0 / 0.1 mm/step]

1003	[Paper Buckle] Paper Buckle Adjustment (Tray Location, Paper Type), Paper Type: N: Normal, TH: Thick		
	Adjusts the amount of paper buckle at the registration roller by changing the paper feed timing.		
	001	Tray1:Plain	*ENG [-11 to 9 / -1 / 1 mm/step]
	002	Tray1: Middle Thick	*ENG [-11 to 9 / -1 / 1 mm/step]
003	Tray1:Thick1	*ENG [-11 to 9 / -3 / 1 mm/step]	

004	Tray234:Plain	*ENG	[-11 to 9 / -1 / 1 mm/step]
005	Tray234: Middle Thick	*ENG	[-11 to 9 / -1 / 1 mm/step]
006	Tray234:Thick1	*ENG	[-11 to 9 / -3 / 1 mm/step]
007	By-pass:Plain	*ENG	[-11 to 9 / -1 / 1 mm/step]
008	By-pass: Middle Thick	*ENG	[-11 to 9 / -1 / 1 mm/step]
009	By-pass:Thick1	*ENG	[-11 to 9 / -3 / 1 mm/step]
010	Duplex:Plain	*ENG	[-11 to 9 / -2 / 1 mm/step]
011	Duplex: Middle Thick	*ENG	[-11 to 9 / -2 / 1 mm/step]
012	Duplex:Thick1	*ENG	[-11 to 9 / -3 / 1 mm/step]
013	Paper Tray1:Plain:1200dpi	*ENG	[-11 to 9 / -1 / 1 mm/step]
014	Paper Tray1: Middle Thick: 1200dpi	*ENG	[-11 to 9 / -1 / 1 mm/step]
015	Paper Tray1:Thick1:1200dpi	*ENG	[-11 to 9 / -3 / 1 mm/step]
016	Tray2/3/4:Plain:1200dpi	*ENG	[-11 to 9 / -1 / 1 mm/step]
017	Tray2/3/4:M-Thick:1200dpi	*ENG	[-11 to 9 / -1 / 1 mm/step]
018	Tray2/3/4:Thick1:1200dpi	*ENG	[-11 to 9 / -3 / 1 mm/step]
019	By-pass:Plain:1200dpi	*ENG	[-11 to 9 / -1 / 1 mm/step]
020	By-pass: Middle Thick:1200dpi	*ENG	[-11 to 9 / -1 / 1 mm/step]
021	By-pass:Thick1:1200dpi	*ENG	[-11 to 9 / -3 / 1 mm/step]
022	Duplex:Plain:1200dpi	*ENG	[-11 to 9 / -1 / 1 mm/step]
023	Duplex: Middle Thick:1200dpi	*ENG	[-11 to 9 / -1 / 1 mm/step]
024	Duplex:Thick1:1200dpi	*ENG	[-11 to 9 / -3 / 1 mm/step]

1007	[By-pass Size Detection LG]		
	Selects the paper size detection.		
001	0: Letter A4, 1: Legal	*ENG	[0 to 1 / 0 / 1 /step]

1040	[Scanner: LT/LG Mixed Size Setting]
	<p>This machine supports copying and scanning of mixed LTR/LG size originals. However, this feature is not enabled by default. This SP switches this feature on/off for scanning</p> <p>Note:</p> <ul style="list-style-type: none"> • The paper bank option is required to use this feature with the scanner. • The scanner service mode must also be switched on with SP5076 [Copy: LT/LG Mixed Sizes Setting] because its default setting is "0" (OFF).
	<p>[0 to 1/0/1]</p> <p>0: OFF</p> <p>1: ON</p>

1103	[Fusing Idling] Fusing Idling Adjustment		
016 to 018	Specifies how long the extra idling operation is executed for each environment. Each environment is determined with SP1112-001 and 002.		
016	Extra Idling Time (L)	*ENG	[0 to 60 / 20 / 1 sec/step]
017	Extra Idling Time (H)	*ENG	[0 to 60 / 0 / 1 sec/step]
018	Extra Idling Time (M)	*ENG	[0 to 60 / 0 / 1 sec/step]
019	Ex Idling Temp:P-Roll	*ENG	[0 to 160 / 110 / 1 deg/step]

1104	[Fusing Idling Before Job]		
001	Environment Thresh	*ENG	<p>[0 to 2 / 2 / 1 /step]</p> <p>0: Low Temp</p> <p>1: Low/Normal</p> <p>2: All Env</p>
002	Idling Temp:P-Roll	*ENG	[0 to 160 / 160 / 1 deg /step]
	Specifies the threshold temperature for the pressure roller idling before a job.		

003	Idling Time: BW	*ENG	Specifies the fusing idling time for each printe mode before a job. [0 to 10 / 2 / 1 sec/step]
004	Idling Time: FC	*ENG	
005	Idling Time: M-Thick: BW	*ENG	
006	Idling Time: M-Thick: FC	*ENG	
007-009	Specifies the thereshold temperature of the paper feed before a job.		
007	Paper Feed Temp:P-Roller	*ENG	[0 to 160 / 90/ 1 deg/step]
008	P.Feed Temp:MThick:P-Roll:BW	*ENG	[0 to 160 / 100/ 1 deg/step]
009	P.Feed Temp:MThick:P-Roll:FC	*ENG	[0 to 160 / 100/ 1 deg/step]
010	Fusing Upper Limit Temp	*ENG	[0 to 100 / 25/ 1 deg/step]
011	Offset: Feed Start	*ENG	[0 to 100 / 20/ 1 deg/step]
012	Offset: Feed Start: M-Thick	*ENG	[0 to 100 / 10/ 1 deg/step]
013	Offset: Feed Start: 600dpi: Plain1: BW	*ENG	[0 to 100 / 25/ 1 deg/step]
014	Offset: Feed Start: 600dpi: Plain2: BW	*ENG	[0 to 100 / 25/ 1 deg/step]
030	Feed Start: Time	*ENG	[15 to 500 / 60 / 1 sec/step]
031	Offset:Feed Start:1200dpi	*ENG	[0 to 100 / 15 / 1 deg/step]
033	Offset: Feed Start: Glossy	*ENG	[0 to 100 / 15 / 1 deg/step]

1105	[Fusing Temperature] Fusing Temperature Adjustment		
	(Printing Mode, Roller Type, [Color], Simplex/Duplex) Roller Type -> Center and Ends: Heating roller, P-Roller -> Pressure roller Paper Type -> Plain, Thin, Thick, OHP, Middle Thick, Special		
001	Fusing Ready Temp.	*ENG	[100 to 180 / 160 / 1 deg/step]
	Specifies the heating roller target temperature for the ready condition.		
002	Fusing Ready: Offset	*ENG	[5 to 30 / 11 / 1 deg/step]
003	P-Roll Ready Target Temp.	*ENG	[50 to 160 / 120 / 1 deg/step]

	P-Roll Ready Temp.	*ENG	[0 to 150 / 20 / 1 deg/step]
007	Sets the heating roller offset temperature at the end of the heating roller. This value is one of the thresholds to determine if the machine is at the heating roller target temperature during warm-up.		
010	Stand-By: Center	* ENG	[50 to 180 / 160 / 1 deg/step]
011	Stand-By: Ends	* ENG	[50 to 180 / 160 / 1 deg/step]
	Stand-By:P-Roller	* ENG	[50 to 160 / 140 / 1 deg/step]
012	Sets the pressure roller offset temperature. This value is one of the thresholds to determine if the machine is at the heating roller target temperature during warm-up.		
	Panel Off Mode: Center	* ENG	[50 to 180 / 140 / 1 deg /step]
013	Specifies the heating roller temperature (center) in the panel off mode.		
	Panel Off Mode: Ends	* ENG	[50 to 180 / 140 / 1 deg /step]
014	Specifies the heating roller temperature (both ends) in the panel off mode.		
	Panel Off Mode: P-Roller	*ENG	[50 to 160 / 120 / 1 deg /step]
015	Specifies the pressure roller temperature in the panel off mode.		
016	Low Power: Center	*ENG	Specifies the heating roller temperature (center or ends) in the low power mode.
017	Low Power: Ends	*ENG	
			[30 to 180 / 40 / 1 deg /step]
	Low Power: P-Roller	*ENG	[30 to 160 / 110 / 1 deg /step]
018	Specifies the pressure roller temperature in the low power mode.		
019	Off Mode: Center	*ENG	Specifies the heating roller temperature (center or ends) in the sleep mode.
020	Off Mode: Ends	*ENG	
			[0 to 180 / 0 / 1 deg /step]
	Off Mode:P-Roller	*ENG	[0 to 170 / 0 / 1 deg /step]
021	Specifies the pressure roller temperature in the sleep mode.		
030 to 239	The target fusing temperature for each paper type and mode can be adjusted by the following SPs.		

030	Plain1:FC:Simplex:Center	*ENG	[100 to 180 / 155 / 1 deg /step]
031	Plain1: FC: Simplex: Ends	*ENG	
032	Plain1:FC:Duplex:Center	*ENG	
033	Plain1: FC: Duplex: Ends	*ENG	
034	Plain1: BW: Simplex:Center	*ENG	
035	Plain1: BW: Simplex: Ends	*ENG	
036	Plain1: BW: Duplex:Center	*ENG	
037	Plain1: BW: Duplex: Ends	*ENG	
038	Thin: FC: Simplex:Center	*ENG	[100 to 180 / 145 / 1 deg /step]
039	Thin: FC: Simplex: Ends	*ENG	
040	Thin:FC:Duplex:Center	*ENG	
041	Thin:FC:Duplex:Ends	*ENG	
042	Thin: BW: Simplex:Center	*ENG	
043	Thin: BW: Simplex: Ends	*ENG	
044	Thin: BW: Duplex:Center	*ENG	
045	Thin:BW:Duplex:Ends	*ENG	
046	Thick 1: FC: Simplex:Center	*ENG	[100 to 180 / 165 / 1 deg /step]
047	Thick 1: FC: Simplex: Ends	*ENG	
048	Thick 1: FC: Duplex:Center	*ENG	
049	Thick 1: FC: Duplex:Ends	*ENG	
050	Thick 1: BW: Simplex:Center	*ENG	
051	Thick 1: BW: Simplex: Ends	*ENG	
052	Thick 1: BW: Duplex:Center	*ENG	
053	Thick 1:BW:Duplex:Ends	*ENG	
054	Thick 2: FC: Simplex:Center	*ENG	[100 to 180 / 140 / 1 deg /step]
055	Thick 2: BW: Simplex:Center	*ENG	

056	OHP: FC	*ENG	[100 to 180 / 160 / 1 deg /step]
057	OHP: BW	*ENG	
058	SP 1:FC:Simplex:Center	*ENG	[100 to 180 / 170 / 1 deg/step]
059	SP 1:FC:Simplex:Ends	*ENG	
060	SP 1:FC:Duplex:Center	*ENG	
061	SP 1:FC:Duplex:Ends	*ENG	
062	SP 1:BW:Simplex:Center	*ENG	
063	SP 1:BW:Simplex:Ends	*ENG	
064	SP 1:BW:Duplex:Center	*ENG	
065	SP 1: BW: Duplex: Ends	*ENG	
066	SP 2:FC:Simplex:Center	*ENG	[100 to 200 / 165 / 1 deg/step]
067	SP 2: FC: Simplex: Ends	*ENG	
068	SP 2:FC:Duplex:Center	*ENG	
069	SP 2:FC:Duplex:Ends	*ENG	
070	SP 2:BW:Simplex:Center	*ENG	
071	SP 2:BW:Simplex:Ends	*ENG	
072	SP 2:BW:Duplex:Center	*ENG	
073	SP 2:BW:Duplex:Ends	*ENG	
074	SP 3:FC:Simplex:Center	*ENG	[100 to 200 / 150 / 1 deg/step]
075	SP 3:FC:Simplex:Ends	*ENG	
076	SP 3:FC:Duplex:Center	*ENG	
077	SP 3:FC:Duplex:Ends	*ENG	
078	SP 3:BW:Simplex:Center	*ENG	
079	SP 3:BW:Simplex:Ends	*ENG	
080	SP 3:BW:Duplex:Center	*ENG	
081	SP 3:BW:Duplex:Ends	*ENG	

082	Target Temp. After Ready	*ENG	[100 to 180 / 160 / 1 deg/step]
	Specifies the target temperature for the maintain mode after the machine has reached the target temperature in warm-up mode.		
083	Recovery Target Temp.	*ENG	[100 to 180 / 160 / 1 deg /step]
	Specifies the target temperature for the print mode without printing job after the machine's recovery.		
087	Thick 2: FC: Simplex: Ends	*ENG	[100 to 180 / 140 / 1 deg/step]
088	Thick 2: BW: Simplex: Ends	*ENG	
089	Thick 3: FC: Simplex: Center	*ENG	[100 to 180 / 160 / 1 deg/step]
090	Thick 3: FC: Simplex: Ends	*ENG	
091	Thick 3: BW: Simplex: Center	*ENG	
092	Thick 3: BW: Simplex: Ends	*ENG	
109	M-Thick:FC:Simplex:Center	*ENG	
110	M-Thick:FC:Duplex:Center	*ENG	[100 to 180 / 175 / 1 deg/step]
111	M-Thick: BW: Simplex:Center	*ENG	
112	M-Thick: BW: Duplex:Center	*ENG	
113	M-Thick: FC: Simplex: Ends	*ENG	
114	M-Thick: FC: Duplex: Ends	*ENG	
115	M-Thick: BW: Simplex: Ends	*ENG	
116	M-Thick: BW: Duplex: Ends	*ENG	

120	Plain2: FC: Simplex:Center	*ENG	[100 to 180 / 160 / 1 deg/step]
121	Plain2: FC: Simplex:Ends	*ENG	
122	Plain2: FC: Duplex:Center	*ENG	
123	Plain2: FC: Duplex:Ends	*ENG	
124	Plain2: BW: Simplex:Center	*ENG	
125	Plain2: BW: Simplex: Ends	*ENG	
126	Plain2: BW: Duplex:Center	*ENG	
127	Plain2: BW: Duplex: Ends	*ENG	
128	F: Plain 1: FC : Simplex:Center	*ENG	[100 to 180 / 125 / 1 deg/step]
129	F: Plain 1: FC : Simplex: Ends	*ENG	
130	F: Plain 1: BW : Simplex:Center	*ENG	
131	F: Plain 1: BW : Simplex: Ends	*ENG	
132	F: Plain2: FC: Simplex:Center	*ENG	[100 to 180 / 130 / 1 deg /step]
133	F: Plain2: FC: Simplex: Ends	*ENG	
134	F: Plain2: BW: Simplex:Center	*ENG	
135	F: Plain2: BW: Simplex: Ends	*ENG	
136	F: MThick: FC: Simplex:Center	*ENG	
137	F: MThick: FC: Simplex: Ends	*ENG	
138	F: MThick: BW: Simplex:Center	*ENG	
139	F: MThick: BW: Simplex: Ends	*ENG	
142	Glossy: Plain 1:Center	*ENG	
143	Glossy: Plain 1: Ends	*ENG	

144	Glossy: Plain2:Center	*ENG	[100 to 180 / 135 / 1 deg/step]
145	Glossy: Plain2: Ends	*ENG	
146	Glossy: MThick:Center	*ENG	
147	Glossy: MThick: Ends	*ENG	
160	F: Thick1:FC:Simplex:Center	*ENG	
161	F: Thick1:FC:Simplex:Ends	*ENG	
162	F: Thick1:BW:Simplex:Center	*ENG	
163	F: Thick1:BW:Simplex:Ends	*ENG	
164	F: SP 1:FC:Simplex:Center	*ENG	
165	F: SP 1:FC:Simplex:Ends	*ENG	
166	F: SP 1:BW: Simplex:Center	*ENG	
167	F: SP 1:BW: Simplex:Ends	*ENG	
168	F: SP 2:FC Simplex:Center	*ENG	
169	F: SP 2:FC Simplex:Ends	*ENG	
170	F: SP 2:BW:Simplex:Center	*ENG	
171	F: SP 2:BW:Simplex:Ends	*ENG	
201	Plain1:Simplex:Press	*ENG	[50 to 160 / 120 / 1 deg/step]
202	Thin:Simplex:Press	*ENG	[50 to 160 / 115 / 1 deg/step]
203	Thick1:Simplex:Press	*ENG	[50 to 160 / 130 / 1 deg/step]
204	Thick2:Simplex:Press	*ENG	[50 to 160 / 115 / 1 deg/step]
205	Thick3:Simplex:Press	*ENG	[50 to 160 / 115 / 1 deg/step]
206	OHP:Press	*ENG	[50 to 160 / 80 / 1 deg/step]
207	SP 1:Simplex: Press	*ENG	[50 to 160 / 120 / 1 deg/step]
208	SP 2:Simplex: Press	*ENG	[50 to 160 / 130 / 1 deg/step]
209	SP 3:Simplex: Press	*ENG	[50 to 160 / 115 / 1 deg/step]
210	MThick:Simplex: Press	*ENG	[50 to 160 / 130 / 1 deg/step]

211	Plain2:Simplex:Press	*ENG	[50 to 160 / 125 / 1 deg/step]
212	F: Plain 1:Simplex:Press	*ENG	[50 to 160 / 105 / 1 deg/step]
213	F: Plain2:Simplex:Press	*ENG	[50 to 160 / 110 / 1 deg/step]
214	F: MThick:Simplex: Press	*ENG	[50 to 160 / 115 / 1 deg/step]
215	Glossy: Plain 1:Simplex: Press	*ENG	[50 to 160 / 105 / 1 deg/step]
216	Glossy: Plain2:Simplex: Press	*ENG	[50 to 160 / 110 / 1 deg/step]
217	Glossy: MThick:Simplex: Press	*ENG	[50 to 160 / 115 / 1 deg/step]
220	F: Thick 1:Simplex: Press	*ENG	[50 to 160 / 115 / 1 deg/step]
221	F: SP 1:Simplex: Press	*ENG	[50 to 160 / 105 / 1 deg/step]
222	F: SP 2:Simplex: Press	*ENG	[50 to 160 / 115 / 1 deg/step]
223	Plain 1:Duplex: Press	*ENG	[50 to 160 / 90 / 1 deg/step]
224	Thick 1:Duplex: Press	*ENG	
225	Thick 2:Duplex: Press	*ENG	
226	SP 1:Duplex: Press	*ENG	
227	SP 2:Duplex: Press	*ENG	
228	SP 3:Duplex: Press	*ENG	
229	MThick:Duplex: Press	*ENG	
230	Plain 2:Duplex: Press	*ENG	
231	F: Plain 1:Duplex: Press	*ENG	
232	F: Plain 2:Duplex: Press	*ENG	

233	F: MThick:Duplex: Press	*ENG	[50 to 160 / 90 / 1 deg/step]
234	Glossy: Plain1: Duplex: Press	*ENG	
235	Glossy: Plain2: Duplex: Press	*ENG	
236	Glossy: MThick: Duplex: Press	*ENG	
237	F: Thick1:Duplex: Press	*ENG	
238	F: SP 1:Duplex: Press	*ENG	
239	F: SP 2:Duplex: Press	*ENG	

1106	[Fusing Temperature Display]		
	Fusing Temperature Display (Heating or Pressure)		
Displays the current temperature of the heating and pressure rollers.			
001	Fusing Roller: Center	-	[-20 to 250 / 0 / 1 deg/step]
002	Fusing Roller: Ends	-	[-10 to 250 / 0 / 1 deg/step]
The heating roller has two lamps. One heats the center of the heating roller and the other heats both ends of the heating roller.			
003	Pressure Roller: Center	-	[-10 to 250 / 0 / 1 deg/step]
The pressure roller has two lamps. One heats the center of the heating roller and the other heats both ends of the heating roller.			

1108	[Ready Temp Setting]		
	Japan use only		
007	Ready Temp Time	*ENG	[22 to 60 / 43 / 0.1 sec/step]

1109	[Fusing Nip Band Check]		
001	Execute	-	[0 or 1 / 0 / 1] Executes the nip band measurement between fusing belt and pressure roller. If the nip band width is not 8 mm, and fusing is not good, replace the pressure roller or install a new fusing unit.

002	Pre-Idling Time	*ENG	[0 to 120 / 0 / 1 sec/step]
	Specifies the fusing rotation time before executing SP1109-001.		
003	Stop Time	*ENG	[5 to 30 / 20 / 1 sec/step]
	Specifies the time for measuring the nip.		

1112	[Environment Correction: Fusing]		
001	Temp.: Threshold: Low	*ENG	[10 to 23 / 17 / 1 deg/step]
	Specifies the threshold temperature for low temperature condition.		
002	Temp.: Threshold: High	*ENG	[24 to 40 / 30 / 1 deg/step]
	Specifies the threshold temperature for high temperature condition.		
003	Low Temp. Correction	*ENG	[0 to 15 / 5 / 1 deg/step]
	Specifies the temperature correction for the heating roller. When the low temperature condition (specified with SP1112-001) is detected, the value of this SP is added to the heating roller temperature.		
004	High Temp. Correction	*ENG	[0 to 15 / 3 / 1 deg/step]
	Specifies the temperature correction for the heating roller. When the high temperature condition (specified with SP1112-002) is detected, the value of this SP is subtracted from the heating roller temperature.		
005	Job Low Temp. Correction	*ENG	[0 to 15 / 5 / 0.1 deg/step]
006	Job High Temp. Correction	*ENG	[0 to 15 / 3 / 0.1 deg/step]

System SP1-xxx: 2

SP1-XXX (Feed)

1113	[Stand-by Mode Setting]		
001	Wait Time AF Ready	*ENG	[0 to 60 / 30 / 1 sec/step]
003	Wait Time AF Recovery	*ENG	[0 to 60 / 10 / 1 sec/step]
	Specifies the time for keeping the target temperature without any jobs after recovery (SP1 105-083).		
004	Wait Time AF Job	*ENG	[0 to 60 / 10 / 1 sec/step]
	Specifies the time for keeping the target temperature without any jobs after a last job.		
005	P-Roll Thresh AF Ready	*ENG	[0 to 160 / 120 / 1 deg/step]
	Specifies the threshold temperature of the pressure roller for entering the wait time mode (SP1-113-001).		
006	P-Roll Thresh AF Job	*ENG	[0 to 160 / 100 / 1 deg/step]
	Specifies the threshold temperature of the pressure roller for entering the wait time mode (SP1-113-004).		
008	On/Off SW Timer	*ENG	[0 to 999 / 300 / 1 sec/step]
	Specifies the interval for entering the PID control from the On/Off control.		

1115	[Stand-by Idling]		
001	Interval	*ENG	[0 to 240 / 60 / 1 min/step]
	Specifies the interval between idling during stand-by mode. This idling during the stand-by mode prevents the roller deformation.		
002	Idling Time	*ENG	[0 to 60 / 2 / 0.1 sec/step]
	Specifies the length of each idling operation during stand-by mode.		
003	Idling Speed	*ENG	[0 to 1 / 0 / 1 mm/sec/step]

1116	[Fusing Temp Change] Paper Type → MThick: Middle Thick		
	Center Temp. 1	ENG	[-10 / 10 / 0 / 1 deg/step]
010	Specifies the temperature correction for the heating roller (center) when the paper width is 226 mm or more. The start time of this SP can be adjusted with SP1116-018.		
011	Ends Temp. 1	ENG	[-10 to 10 / 0 / 1 deg/step]
	Specifies the temperature correction for the heating roller (ends) when the paper width is 226 mm or more. The start time of this SP can be adjusted with SP1116-018.		
012	Center Temp. 2	ENG	[-10 to 10 / 0 / 1 deg/step]
	Specifies the temperature correction for the heating roller (center) when the paper width is 226 mm or more. The start time of this SP can be adjusted with SP1116-019.		
013	Ends Temp. 2	ENG	[-10 to 10 / 0 / 1 deg/step]
	Specifies the temperature correction for the heating roller (ends) when the paper width is 226 mm or more. The start time of this SP can be adjusted with SP1116-019.		
018	Control Time 1	ENG	[0 to 250 / 0 / 1 sec/step]
	Specifies the start time of the temperature correction that is set with SP1116-010 and -011. The temperature correction is added when the time specified with this SP has passed after feeding the paper.		
019	Control Time 2	ENG	[0 to 250 / 0 / 1 sec/step]
	Specifies the start time of the temperature correction that is set with SP1116-012 and -013. The temperature correction is added when the time specified with this SP has passed after feeding the paper.		

022	Center Temp.1:MThick	ENG	[-10 to 10 / 0 / 1 deg/step]
023	Ends Temp.1:MThick	ENG	
024	Center Temp.2:MThick	ENG	
025	Ends Temp.2:MThick	ENG	
030	Center Temp.1:Other	ENG	
031	Ends Temp.1:Other	ENG	
032	Center Temp.2:Other	ENG	
033	Ends Temp.2:Other	ENG	

5

1118	[Curl Correction]		
001	Execute Pattern	*ENG	[0 to 4 / 0 / 1]
	Selects the curl correction mode. 0: Invalid 1: 600 dpi 2: 1200 dpi 3: 600/1200 dpi Note <ul style="list-style-type: none"> This SP is not effective for all curl situations. Use this SP if you see a sharp back curl after the machine recovered from "OFF mode" in a high temperature and humidity environment. 		
002	Humidity Thresh 1	*ENG	[0 to 100 / 65 / 1 %]
	Specifies the first threshold humidity for executing the curl correction.		
003	Humidity Thresh 2	*ENG	[0 to 100 / 80 / 1 %]
	Specifies the second threshold humidity for executing the curl correction.		
004	Pattern 1: MM: H-Roll	*ENG	[-30 to 0 / -3 / 1 deg]
005	Pattern 1: MM: P-Roll	*ENG	[0 to 60 / 0 / 1 deg]
006	Pattern 1: HM: H-Roll	*ENG	[-30 to 0 / 0 / 1 deg]
007	Pattern 1: HM: P-Roll	*ENG	[0 to 60 / 0 / 1 deg]

008	Pattern 2: MM: H-Roll	*ENG	[-30 to 0 / -5 / 1 deg]
009	Pattern 2: MM: P-Roll	*ENG	[0 to 60 / 50 / 1 deg]
010	Pattern 2: HM: H-Roll	*ENG	[-30 to 0 / -5 / 1 deg]
011	Pattern 2: HM: P-Roll	*ENG	[0 to 60 / 50 / 1 deg]

1120	[Multi-Print Mode]		
001	Feed Condition	*ENG	[0 or 2 / 0 / 1]
	<p>Selects the paper feed timing. 0: Productivity priority, 1: Fusing quality priority</p>		
	<p>Note: When the print paper size changes from a small to a large size, you can stop the print job in order to ensure that the fusing temperature is high enough, and then resume it when the proper temperature has been reached. This mode is used on machines in which the fusing ability is low, for example when there is one fusing lamp. And it is mainly used on A3 MFPs which change repeatedly between A3 and A4 size. However, it is not used on machines in which there are two heating lamps, such as A4 MFPs which almost never change between A4 and A5.</p>		

1121	[Maximum Duty Switch]		
	Control Method Switch	*ENG	[0 or 1 / 1 / 1]
001	<p>Selects the power control method for the fusing unit. 0: Fixed control, 1: Power control The machine is used over the rated voltage of PSU. For example, 1700w can be used at the machine of 1500w. When the fusing ability is too low early morning, or the electrical power environment is not stable, this switch can be used. However, there is a risk of over-voltage when using this SP, since it is not used under normal conditions.</p>		

1135	[Inrush Control]		
-------------	-------------------------	--	--

001	<p>[0 to 1 / 0 / 1 step]</p> <p>0: Normal</p> <p>1: Inrush current control</p> <p>The inrush current control is designed for a UPS and specific breaker (45A or less). Normally, this setting is not adjusted.</p>		
-----	--	--	--

1159	[Fusing Jam Detection]		
001	SC Display	*ENG	[0 or 1 / 0 / 1]
	<p>Enables or disables the fusing consecutive jam (three times) SC detection.</p> <p>0: No detection, 1: Detection</p>		

5

1201	[CPM Down Setting] DFU		
001	Low: Down Temp.	*ENG	[-50 to 0 / -10/ 1 deg/step]
002	Low: Up Temp.	*ENG	[-50 to 0 / -7/ 1 deg/step]
003	Low: 1st CPM	*ENG	[10 to 100 / 80 / 5 %]
004	Low: 2nd CPM	*ENG	[10 to 100 / 65 / 5 %]
005	Low: 3rd CPM	*ENG	[10 to 100 / 50 / 5 %]
006	Unit Low Judge Temp.	*ENG	[0 to 100 / 65/ 1 deg/step]
007	High: 1st CPM	*ENG	[10 to 100 / 75 / 5 %]
008	High: 2nd CPM	*ENG	[10 to 100 / 50 / 5 %]
009	High: 3rd CPM	*ENG	[10 to 100 / 25 / 5 %]
010	High: 1st CPM Down Temp.	*ENG	[160 to 240 / 210/ 1 deg/step]
011	High: 2nd CPM Down Temp.	*ENG	[160 to 240 / 215/ 1 deg/step]
012	High: 3rd CPM Down emp.	*ENG	[160 to 240 / 220/ 1 deg/step]
021	Judging Interval	*ENG	[1 to 250 / 10/ 1 sec/step]

1801	<p>[Motor Speed Adjust] FA</p> <p>Low: 85 mm/s, High: 260 mm/s, Middle: 182 mm/s</p>		
-------------	---	--	--

001	Registration:Plain: Low	*ENG	[-4 to 4 / 0.4 / 0.1 %]
002	Registration:Plain: High	*ENG	
003	Registration: Middle Thick: Low	*ENG	
004	Registration:Middle Thick: High	*ENG	
005	Registration:Thick1: Low	*ENG	[-4 to 4 / 0.7 / 0.1 %]
006	Registration:Thick1: Middle	*ENG	
008	BkOpcDevMot (ITB Unit/ Drum: K/ Development: K Motor): 260	*ENG	[-4 to 4 / 0.15 / 0.1 %]
009	BkOpcDevMot (ITB Unit/ Drum: K/ Development: K Motor): 182	*ENG	
011	BkOpcDevMot (ITB Unit/ Drum: K/ Development: K Motor): 85	*ENG	
013	ColorOpcMot (Drum Motor: CMY): 260	*ENG	[-11 to 11 / 0 / 1 step]
014	ColorOpcMot (Drum Motor: CMY): 182	*ENG	[-15 to 15 / 0 / 1 step]
016	ColorOpcMot (Drum Motor: CMY): 85	*ENG	[-80 to 80 / 0 / 1 step]
019	FusingMot (Fusing/ Paper Exit Motor): 260	*ENG	[-4 to 4 / -1.85 / 0.1 %]
020	FusingMot (Fusing/ Paper Exit Motor): 182	*ENG	
022	FusingMot (Fusing/ Paper Exit Motor): 85	*ENG	[-4 to 4 / 1.55 / 0.1 %]
029	Registration:Thick2: Low	*ENG	[-4 to 4 / 0.7 / 0.1 %]
030	Registration:Thick3: Low	*ENG	

031	Feed:Plain: Low	*ENG	[-2 to 2 / 0.4 / 0.1 %]
032	Feed:Plain: High	*ENG	
033	Feed: Middle Thick: Low	*ENG	
034	Feed: Middle Thick: High	*ENG	
035	Feed:Thick1: Low	*ENG	[-2 to 2 / 0.7 / 0.1 %]
036	Feed:Thick1: Middle	*ENG	
037	Feed:Thick2: Low	*ENG	
038	Feed:Thick3: Low	*ENG	
039	VerticalTransport:Plain: Low	*ENG	[-2 to 2 / 0.4 / 0.1 %]
040	VerticalTransport:Plain: High	*ENG	
041	VerticalTransport: Middle Thick: Low	*ENG	
042	VerticalTransport: Middle Thick: High	*ENG	
043	VerticalTransport:Thick1: Low	*ENG	[-2 to 2 / 0.7 / 0.1 %]
044	VerticalTransport:Thick1: Middle	*ENG	
045	VerticalTransport:Thick2: Low	*ENG	
046	VerticalTransport:Thick3: Low	*ENG	
047	Duplex CW:Plain: Low	*ENG	[-4 to 4 / 0.4 / 0.1 %]
048	Duplex CW:Plain: High	*ENG	
049	Duplex CW: Middle Thick: Low	*ENG	
050	Duplex CW: Middle Thick: High	*ENG	
051	Duplex CW:Thick1: Low	*ENG	[-4 to 4 / 0.7 / 0.1 %]
052	Duplex CW:Thick1: Middle	*ENG	
053	Duplex CW:Thick2: Low	*ENG	
054	Duplex CW:Thick3: Low	*ENG	

055	Duplex CCW:Plain: Low	*ENG	[-4 to 4 / 0.4 / 0.1 %]
056	Duplex CCW:Plain: High	*ENG	
057	Duplex CCW: Middle Thick: Low	*ENG	
058	Duplex CCW: Middle Thick: High	*ENG	
059	Duplex CCW:Thick1: Low	*ENG	[-4 to 4 / 0.7 / 0.1 %]
060	Duplex CCW:Thick1: Middle	*ENG	
061	Duplex CCW:Thick2: Low	*ENG	
062	Reverse CW:Plain: Low	*ENG	[-4 to 4 / -0.4 / 0.1 %]
063	Reverse CW:Plain: High	*ENG	[-4 to 4 / -0.7 / 0.1 %]
064	Reverse CW: Middle Thick: Low	*ENG	[-4 to 4 / -0.4 / 0.1 %]
065	Reverse CW: Middle Thick: High	*ENG	[-4 to 4 / -0.7 / 0.1 %]
066	Reverse CW: Thick1: Low	*ENG	[-4 to 4 / -0.4 / 0.1 %]
067	Reverse CW: Thick1: Middle	*ENG	[-4 to 4 / -0.7 / 0.1 %]
068	Reverse CW: Thick2: Low	*ENG	[-4 to 4 / -0.4 / 0.1 %]
069	Reverse CCW:Plain: Low	*ENG	[-4 to 4 / -0 / 0.1 %]
070	Reverse CCW:Plain: High	*ENG	
071	Reverse CCW: Middle Thick: Low	*ENG	
072	Reverse CCW: Middle Thick: High	*ENG	
073	Reverse CCW: Thick1: Low	*ENG	
074	Reverse CCW: Thick1: Middle	*ENG	
075	Reverse CCW: Thick2: Low	*ENG	
101	Offset: 260: Color	*ENG	[-11 to 11 / 0 / 1 step]
102	Offset: 182: Color	*ENG	[-15 to 15 / 0 / 1 step]
103	Offset: 85: Color	*ENG	[-80 to 80 / 0 / 1 step]
130	OpcMot (Drum Motor) Adjust Control	*ENG	[0 to 1 / 1 / 1 step]

1902		[Gain Control]	
001	Execute	*ENG	Execute drum phase adjustment.
002	Result	*ENG	[0 to 3 / 0/ 1] Displays the result of drum phase adjustment. 0: Successfully done 2: Sampling failure 3: Insufficient detection number
003	Auto Execute	*ENG	[0 or 1 / 1/ -] Turns the automatic drum phase adjustment on or off. 0: Off, 1: On

1907		[Paper Feed Timing Adj.] DFU	
001	Feed Solenoid ON: Plain	*ENG	[-10 to 40 / 0/ 2.5 mm/step]
002	Feed STM OFF: Plain	*ENG	[-10 to 10 / 0/ 1 mm/step]
003	Feed STM ON: Plain	*ENG	
004	Feed Solenoid ON: Thick	*ENG	[-10 to 40 / 0/ 2.5 mm/step]
005	Feed STM OFF: Thick	*ENG	[-10 to 10 / 0/ 1 mm/step]
006	Feed STM ON: Thick	*ENG	
007	Feed Start: Low	*ENG	
008	Duplex CW STM ON: Low	*ENG	
009	Duplex CW STM ON: Middle	*ENG	
010	Duplex CW STM ON: Plain (High)	*ENG	
011	Duplex CW STM OFF: Low	*ENG	
012	Duplex CW STM OFF: Middle	*ENG	
013	Duplex CW STM OFF: High	*ENG	

014	By-pass Solenoid ON: Low	*ENG	[-10 to 40 / 0/ 1 mm/step]
015	By-pass Solenoid ON: Middle	*ENG	
016	By-pass Solenoid ON: High	*ENG	
017	Junctio Gate SOL1: ON: Low	*ENG	[-10 to 10 / 0/ 1 mm/step]
018	Junction Gate SOL1: ON: Middle	*ENG	
019	Junction Gate SOL1: ON: High	*ENG	
020	Junction Gate SOL1: OFF: Low	*ENG	
021	Junction Gate SOL1: OFF: Middle	*ENG	
022	Junction Gate SOL1: OFF: High	*ENG	
023	Junction Gate SOL2: ON: Low	*ENG	[-10 to 10 / 0/ 1 mm/step]
024	Junction Gate SOL2: ON: Middle	*ENG	
025	Junction Gate SOL2: ON: High	*ENG	
026	Junction Gate SOL2: OFF: Low	*ENG	
027	Junction Gate SOL2: OFF: Middle	*ENG	
028	Junction Gate SOL2: OFF: High	*ENG	
029	Paper Tray2/3/4: Feed Solenoid ON: Plain	*ENG	[-10 to 10 / 0/ 1 mm/step]
030	Paper Tray2/3/4: Feed Solenoid OFF: Plain	*ENG	
031	Paper Tray2/3/4: Feed Clutch OFF: Plain	*ENG	
032	Paper Tray2/3/4: Feed STM ON: Plain	*ENG	

033	Paper Tray2/3/4: Feed Solenoid ON: Thick	*ENG	[-10 to 10 / 0/ 1 mm/step]
034	Paper Tray2/3/4: Feed Solenoid OFF: Thick	*ENG	
035	Paper Tray2/3/4: Feed Clutch OFF: Thick	*ENG	
036	Paper Tray2/3/4: Feed STM ON: Thick	*ENG	

1950	[Fan Cooling Time Set]		
	Adjust the rotation time for each fan motor after a job end.		
001	Development Fan1	*ENG	[0 to 600 / 0/ 1 sec/step]
002	Development Fan2	*ENG	
003	Imaging Fan (Laser Unit Fan)	*ENG	
004	Exit Sensor Cooling Fan	*ENG	
005	Exit Fan	*ENG	
006	PSU Fan	*ENG	
007	Paper Feed Drive Fan	*ENG	
008	Toner Supply Fan	*ENG	
009	Controller Fan	*ENG	

5

System SP2-xxx: 1

SP2-XXX (Drum)

2013	[Environmental Correction: PCU]		
007	Current Temp.: Display	*ENG	Displays the current temperature. [0 to 100 / 0 / 1 deg/step]
008	Current Relative Humidity: Display	*ENG	Displays the current relative humidity. [0 to 100 / 0 / 1%RH/step]
009	Current Absolute Humidity: Display	*ENG	Displays the absolute humidity. [0 to 100 / 0 / 0.01 g/m ³ /step]
010	Previous Environmental: Display	*ENG	Displays the previous environmental condition, which is measured in absolute humidity. [1 to 5 / - / 1 /step] 1: LL, 2: ML, 3: MM, 4: MH, 5: HH
011	Previous Temp.: Display	*ENG	Displays the previous temperature. [0 to 100 / 0 / 1 deg/step]
012	Previous Relative Humidity: Display	*ENG	Displays the previous relative humidity. [0 to 100 / 0 / 1%RH/step]
013	Previous Absolute Humidity: Display	*ENG	Displays the previous absolute humidity. [0 to 100 / 0 / 0.01 g/m ³ /step]

[Color Registration Correction]			
2101	These values are the parameters for the automatic line position adjustment and are adjusted at the factory. However, you must input a value for SP2101-001 after replacing the laser unit. For details, see "Laser Unit" in the "Replacement and Adjustment" section. The value should be provided with the new laser unit.		
001	Main Dot: Bk	*ENG	[-511 to 511 / 0 / 1 dot/step]

2102	[Magnification Adjustment] DFU		
	These values are the parameters for the automatic line position adjustment and are adjusted at the factory. These SPs must be input only when a new laser unit is installed.		
001	Main Mag.: Std Speed: Bk	*ENG	[0 to 408 / 204 / 1 /step]
002	Main Mag.:Mid Speed: Bk	*ENG	
003	Main Mag.:Low Speed: Bk	*ENG	
013	Main Beam Pitch: Dot: Bk	*ENG	[-20 to 20 / 9 / 1 dot/step]
014	Main Beam Pitch: Subdot: Bk	*ENG	[-15 to 15 / -3 / 1 sub-dot/step]
015	Main Beam Pitch: Dot: C	*ENG	[-20 to 20 / 9 / 1 dot/step]
016	Main Beam Pitch: Subot: C	*ENG	[-15 to 15 / -3 / 1 sub-dot/step]
017	Main Beam Pitch: Dot: M	*ENG	[-20 to 20 / 9 / 1 dot/step]
018	Main Beam Pitch: Subot: M	*ENG	[-15 to 15 / -4 / 1 sub-dot/step]
019	Main Beam Pitch: Dot: Y	*ENG	[-20 to 20 / 9 / 1 dot/step]
020	Main Beam Pitch: Subot: Y	*ENG	[-15 to 15 / -4 / 1 sub-dot/step]

2103	[Erase Margin Adjustment] (Area, Paper Size)		
	Adjusts the erase margin by deleting image data at the margins.		
001	Lead Edge Width	*ENG	[0 to 9.9 / 4.2 / 0.1 mm/step]
002	Trailing Edge Width	*ENG	
003	Left	*ENG	[0 to 9.9 / 2 / 0.1 mm/step]
004	Right	*ENG	

2104	[Unit LD Power Adj.]		
	Adjusts the LD initial power. These SPs must be input only when a new laser unit is installed.		

001	LD1: K	*ENG	[60 to 140 / 100 / 0.1 %/step]
002	LD2: K	*ENG	
003	LD1: C	*ENG	
004	LD2: C	*ENG	
005	LD1: M	*ENG	
006	LD2: M	*ENG	
007	LD1: Y	*ENG	
008	LD2: Y	*ENG	

2109	[Test Pattern]		
	Generates the test pattern.		
003	Pattern Selection	-	[0 to 23 / 0 / 1/step]
	0 None 1: Vertical Line (1dot) 2: Vertical Line (2dot) 3: Horizontal (1dot) 4: Horizontal (2dot) 5: Grid Vertical Line 6: Grid Horizontal Line 7: Grid Pattern Small 8: Grid Pattern Large 9: Argyle Pattern Small 10: Argyle Pattern Large 11. Independent Pattern (1dot)		12. Independent Pattern (2dot) 13. Independent Pattern (4dot) 14. Trimming Area 15: Hound's Tooth Check (Vertical) 16: Hound's Tooth Check (Horizontal) 17: Band (Horizontal) 18: Band (Vertical) 19: Checker Flag Pattern 20: Grayscale (Vertical Margin) 21: Grayscale (Horizontal Margin) 22: Two Beam Density Pattern 23: Full Dot Pattern
005	Color Selection	-	Specifies the color for the test pattern. [1 to 4 / 1 / 1/step] 1: All color, 2: C, 3: M, 4: Y

006	Density: Bk	-	Specifies the color density for the test pattern. [0 to 15 / 15 / 1 /step] 0: Lightest density 15: Darkest density
007	Density: C	-	
008	Density: M	-	
009	Density: Y	-	

2111	[Forced Line Position Adj.]		
001	Mode a	-	Executes the fine line position adjustment twice. If this SP is not completed (NG is displayed), do SP2111-003 first and then try this SP again.
002	Mode b	-	Executes the fine line position adjustment once. If this SP is not completed, do SP2111-003 first and then try this SP again.
003	Mode c	-	Executes the rough line position adjustment once. After doing this SP, make sure to execute SP2111-001 or -002. Otherwise, the line position adjustment is not perfectly done.
004	Mode d	-	Rough adjustment and fine adjustment, once each.

2112	[TM/ID Sensor Check] ID Sensor Check		
001	Execute		This SP is used to check the ID sensors at the factory. The results of this SP are displayed in SP2140 to SP2145.

2117	[Skew Adjustment]		
Specifies a skew adjustment value for the skew motor M, C or Y.			
001	Pulse: C	*ENG	[-100 to 100 / 0 / 1 pulse/step]
002	Pulse: M	*ENG	
003	Pulse: Y	*ENG	

2118	[Skew Adjustment]		
-------------	--------------------------	--	--

001	Execute: C	*ENG	Changes the current skew adjustment values to the values specified with SP2117.
002	Execute: M	*ENG	
003	Execute: Y	*ENG	

2119	[Skew Adjustment Display]		
	Displays the current skew adjustment value for each skew motor.		
	001	C	*ENG
	002	M	*ENG
003	Y	*ENG	[-75 to 75 / 0 / 1 pulse/step]

2153	[Shade: SP Clear]		
001	SP Clear Execute	*ENG	
	Clears "Shading Correct Setting" (SP2152).		

2180	[Line Pos. Adj. Clear]		
001	Color Regist.	-	
002	Main Scan Length Detection	-	
003	MUSIC Result	-	
004	Area Mag. Correction	-	

2193	[MUSIC Condition Set] DFU			
	Line Position Adjustment: Condition Setting			
	001	Auto Execution	*ENG	[0 or 1 / 1 / 1] 0: OFF, 1: ON
		Enables/disables the automatic line position adjustment.		
002	Page: Job End: BW+FC	*ENG	[0 to 999 / 500 / 1 page/step]	
	Adjusts the threshold of the line position adjustment for BW and color printing mode after job end.			

003	Page: Job End: FC	*ENG	[0 to 999 / 200 / 1 page/step]
	Adjusts the threshold of the line position adjustment for color printing mode after job end.		
004	Page: Interrupt: BW+FC	*ENG	[0 to 999 / 200 / 1 page/step]
	Adjusts the threshold of the line position adjustment for BW and color printing mode during job.		
005	Page: Interrupt: FC	*ENG	[0 to 999 / 200 / 1 page/step]
	Adjusts the threshold of the line position adjustment for color printing mode during jobs.		
006	Page: Standby: BW	*ENG	[0 to 999 / 100 / 1 page/step]
	Adjusts the threshold of the line position adjustment for BW printing mode in stand-by mode. The line position adjustment is done when the number of outputs in BW printing mode reaches the value specified with this SP and the condition of SP2-193-008 or SP2-193-009 is satisfied.		
007	Page: Standby: FC	*ENG	[0 to 999 / 100 / 1 page/step]
	Adjusts the threshold of the line position adjustment for BW printing mode in stand-by mode. The line position adjustment is done when the number of outputs in color printing mode reaches the value specified with this SP and the condition of SP2-193-008 or SP2-193-009 is satisfied.		
008	Temp	*ENG	[0 to 100 / 5 / 1 deg/step]
	Adjust the temperature change threshold for the line position adjustment (Mode b: adjustment once). The timing for line position adjustment depends on the combinations of several conditions.		
009	Time	*ENG	[1 to 1440 / 300 / 1 minute/step]
	Adjust the time threshold for the line position adjustment (Mode b: adjustment once). The timing for line position adjustment depends on the combinations of several conditions.		
010	Magnification	*ENG	[0 to 10 / 1 / 0.1 %/step]
	Adjusts the magnification threshold for line position adjustment. If the length of the main scan is changed by this amount since the previous MUSIC, then MUSIC is done again.		
011	Temp 2	*ENG	[0 to 100 / 10 / 1 deg/step]
	Adjust the temperature change threshold for the line position adjustment (Mode a: adjustment twice). The timing for line position adjustment depends on the combinations of several conditions.		

012	Time 2	*ENG	[1 to 9999 / 600 / 1 minute/step]
	Adjust the time threshold for the line position adjustment (Mode a: adjustment twice). The timing for line position adjustment depends on the combinations of several conditions.		
013	Time 3	*ENG	[1 to 1440 / 300 / 1 minute/step]
014	Page: Full Color Job Before: BW+FC	*ENG	[0 to 999 / 200 / 1 page/step]
015	Page: Full Color Job Before: FC	*ENG	[0 to 999 / 200 / 1 page/step]
016	Page: Power ON:BW+FC	*ENG	[0 to 999 / 200 / 1 page/step]

2194	[MUSIC Execution Result] Line Position Adjustment: Execution Result		
001	Year	*ENG	[0 to 99 / 0 / 1 year/step]
002	Month	*ENG	[1 to 12 / 1 / 1 month/step]
003	Day	*ENG	[1 to 31 / 1 / 1 day/step]
004	Hour	*ENG	[0 to 23 / 0 / 1 hour/step]
005	Minute	*ENG	[0 to 59 / 0 / 1 minute/step]
006	Temperature	*ENG	[0 to 100 / 0 / 1 deg/step]
007	Execution Result	*ENG	[0 or 1 / 0 / 1 /step] 0: Completed successfully, 1: Failed
008	Number of Execution	*ENG	[0 to 999999 / 0 / 1 times/step]
009	Number of Failure	*ENG	[0 to 999999 / 0 / 1 times/step]
010	Error Result: C	*ENG	[0 to 9 / 0 / 1 /step]
011	Error Result: M	*ENG	0: Not done
012	Error Result: Y	*ENG	1: Completed successfully 2: Cannot detect patterns 3: Fewer lines on the pattern than the target 4: Out of the adjustment range 5 to 9: Not used

2220	[Skew Origin Set]		
	Resets the value of the skew adjustment motor for each color. These SPs must be executed when a new laser optics housing unit is installed.		
001	C:Skew Motor	*ENG	-
002	M:Skew Motor	*ENG	
003	Y:Skew Motor	*ENG	

2241	[Temperature/Humidity:Display]		
	Displays the environment temperature and humidity.		
001	Temperature	-	[-1280 to 1270 / 0 / 0.1 deg/step]
002	Relative Humidity	-	[0 to 1000 / 0 / 0.1 %RH/step]
003	Absolute Humidity	-	[0 to 100 / 0 / 0.01 g/m ³ /step]

2302	[Environmental Correction Trans]		
	Environmental Correction: Image Transfer Belt Unit		
001	Current Environmental Display	*ENG	-
002	Forced Setting	*ENG	[0 to 6 / 0 / 1 /step]
	Sets the environment condition manually. 0: Automatic environment control 1: LL (Low temperature/ Low humidity) 2: ML (Middle temperature/ Low humidity) 3: MM (Middle temperature/ Middle humidity) 4: MH (Middle temperature/ High humidity) 5: HH (High temperature/ High humidity) 6: SLL (Super low temperature/ low humidity)		
003	Absolute Humidity: Threshold 1	*ENG	[0 to 100 / 4 / 0.01 g/m ³ /step]
	Adjusts the threshold value between LL and ML.		
004	Absolute Humidity: Threshold 2	*ENG	[0 to 100 / 8 / 0.01 g/m ³ /step]
	Adjusts the threshold value between ML and MM.		

005	Absolute Humidity: Threshold 3	*ENG	[0 to 100 / 16 / 0.01 g/m ³ /step]
	Adjusts the threshold value between MM and MH.		
006	Absolute Humidity: Threshold 4	*ENG	[0 to 100 / 24 / 0.01 g/m ³ /step]
	Adjusts the threshold value between MH and HH.		
007	Temperature:Threshold	*ENG	[-5 to 30 / 5 / 1 deg/step]
	Adjusts the threshold temperature for SLL. If detected temperature is less than a value specified by this SP, SLL condition is determined regardless of humidity.		

2308	[Paper Size Correction]		
	Adjusts the threshold value for the paper size correction.		
001	Threshold 1	*ENG	[0 to 250 / 194 / 1 mm/step] Threshold 1 ≤ paper: Paper is detected as "S1" size.
002	Threshold 2	*ENG	[0 to 250 / 165 / 1 mm/step] Threshold 2 ≤ paper ≤ Threshold 1: Paper is detected as "S2" size.
003	Threshold 3	*ENG	[0 to 250 / 139 / 1 mm/step] Threshold 3 ≤ paper ≤ Threshold 2: Paper is detected as "S3" size.

2311	[Non Image Area: Bias]		
001	Image Transfer	*ENG	Adjusts the bias of the image transfer belt between images. This value is added to the value of the image transfer belt bias. [10 to 250 / 100 / 5 %/step]
002	Paper Transfer	*ENG	Adjusts the bias of the paper transfer roller between images. [0 to 230 / 0 / 1 -μA/step]

2316	[Power ON:Bias]		
-------------	------------------------	--	--

001	Image Transfer	*ENG	[0 to 80 / 5 / 1 μ A /step]
	Adjusts the bias of the image transfer roller at power-on or a closed cover.		

2326	[Transfer Roller CL: Bias] Paper Transfer Roller Cleaning: Bias Adjustment		
001	Positive:before and after JOB	*ENG	[0 to 2100 / 1000 / 10 V /step]
	Adjusts the positive voltage of the paper transfer roller for cleaning the paper transfer roller.		
002	Negative:before and after JOB	*ENG	[10 to 995 / 100 / 10 %/step]
	Adjusts the negative current of the paper transfer roller for cleaning the paper transfer roller.		
003	Positive:after JAM	*ENG	[0 to 2100 / 2000 / 10 V/step]
	Adjusts the negative current limit of the paper transfer roller for cleaning the paper transfer roller.		
004	Negative:after JAM	*ENG	[10 to 995 / 100 / 10 %/step]

2351	[Common: BW: Bias] Image Transfer Belt: B/W: Bias Adjustment Standard: 260 mm/sec, Middle: 182 mm/sec, Low: 85 mm/sec		
001	Image Transfer:Standard Speed	*ENG	[0 to 80 / 26 / 1 μ A]
	Adjusts the current for the image transfer belt in B/W mode for plain paper.		
002	Image Transfer:Middle Speed	*ENG	[0 to 80 / 17 / 1 μ A]
	Adjusts the current for the image transfer belt in B/W mode for M-Thick paper.		
003	Image Transfer:Low Speed	*ENG	[0 to 80 / 7 / 1 μ A]
	Adjusts the current for the image transfer belt in B/W mode for thick 1 paper.		

2357	[Common: FC: Bias]		
	Image Transfer Belt: Full Color: Bias Adjustment Standard: 260 mm/sec, Middle: 182 mm/sec, Low: 85 mm/sec		
001	Image Transfer: Standard Spd:Bk	*ENG	[0 to 80 / 26 / 1 μ A]
	Adjusts the current for the image transfer belt for Black in full color mode for plain paper.		
002	Image Transfer: Standard Spd:C	*ENG	[0 to 80 / 22 / 1 μ A]
	Adjusts the current for the image transfer belt for Magenta in full color mode for plain paper.		
003	Image Transfer: Standard Spd:M	*ENG	[0 to 80 / 22 / 1 μ A]
	Adjusts the current for the image transfer belt for Cyan in full color mode for plain paper.		
004	Image Transfer: Standard Spd:Y	*ENG	[0 to 80 / 22 / 1 μ A]
	Adjusts the current for the image transfer belt for Yellow in full color mode for plain paper.		
005	Image Transfer: Middle Spd:Bk	*ENG	[0 to 80 / 17 / 1 μ A]
	Adjusts the current for the image transfer belt for Black in full color mode for M-Thick paper.		
006	Image Transfer: Middle Spd:C	*ENG	[0 to 80 / 15 / 1 μ A]
	Adjusts the current for the image transfer belt for Magenta in full color mode for M-Thick paper.		
007	Image Transfer: Middle Spd:M	*ENG	[0 to 80 / 15 / 1 μ A]
	Adjusts the current for the image transfer belt for Cyan in full color mode for M-Thick paper.		
008	Image Transfer: Middle Spd:Y	*ENG	[0 to 80 / 15 / 1 μ A]
	Adjusts the current for the image transfer belt for Yellow in full color mode for M-Thick paper.		
009	Image Transfer: Low Speed:Bk	*ENG	[0 to 80 / 7 / 1 μ A]
	Adjusts the current for the image transfer belt for Black in full color mode for thick 1 paper.		

010	Image Transfer: Low Speed:C	*ENG	[0 to 80 / 6 / 1 μ A]
	Adjusts the current for the image transfer belt for Magenta in full color mode for thick 1 paper.		
011	Image Transfer: Low Speed:M	*ENG	[0 to 80 / 6 / 1 μ A]
	Adjusts the current for the image transfer belt for Cyan in full color mode for thick 1 paper.		
012	Image Transfer: Low Speed:Y	*ENG	[0 to 80 / 6 / 1 μ A]
	Adjusts the current for the image transfer belt for Yellow in full color mode for thick 1 paper.		

2360	[Common: BW Env. Correction Table]		
001	Image Transfer: Standard Spd	*ENG	[1 to 100 / 30 / 1 /step]
002	Image Transfer: Middle Spd	*ENG	[1 to 100 / 53 / 1 /step]
003	Image Transfer: Low Spd	*ENG	[1 to 100 / 56 / 1 /step]
[Common: FC Env. Correction Table]			
004	Image Transfer: Standard Spd:BK	*ENG	[1 to 100 / 30 / 1 /step]
005	Image Transfer: Standard Spd: C	*ENG	[1 to 100 / 51 / 1 /step]
006	Image Transfer: Standard Spd:M	*ENG	[1 to 100 / 51 / 1 /step]
007	Image Transfer: Standard Spd:Y	*ENG	[1 to 100 / 52 / 1 /step]
008	Image Transfer: Middle Spd:BK	*ENG	[1 to 100 / 53 / 1 /step]
009	Image Transfer: Middle Spd:C	*ENG	[1 to 100 / 54 / 1 /step]
010	Image Transfer: Middle Spd:M	*ENG	[1 to 100 / 54 / 1 /step]
011	Image Transfer: Middle Spd:Y	*ENG	[1 to 100 / 55 / 1 /step]
012	Image Transfer: Low Spd:Bk	*ENG	[1 to 100 / 57 / 1 /step]
013	Image Transfer: Low Spd:C	*ENG	[1 to 100 / 58 / 1 /step]
014	Image Transfer: Low Spd:M	*ENG	[1 to 100 / 58 / 1 /step]
015	Image Transfer: Low Spd:Y	*ENG	[1 to 100 / 58 / 1 /step]

2401	[Plain 1: Bias]		
	Adjusts the DC voltage of the discharge plate for plain 1 paper. Standard: 260 mm/sec, Low: 85 mm/sec		
001	Separation DC: Standard-Spd: 1stSide	*ENG	[0 to 6000 / 2000 / 10 -V/ step]
002	Separation DC: Standard-Spd: 2ndSide	*ENG	
003	Separation DC: Low-Spd: 1stSide	*ENG	
004	Separation DC: Low-Spd: 2ndSide	*ENG	

2403	[Plain 1: Bias: BW]		
	Adjusts the current for the paper transfer roller for plain 1 paper in black-and-white mode. Standard: 260 mm/sec, Low: 85 mm/sec		
001	Paper Transfer: Standard: 1stSide	*ENG	[0 to 230 / 21 / 1 - μ A /step]
002	Paper Transfer: Standard: 2ndSide	*ENG	[0 to 230 / 23 / 1 - μ A /step]
003	Paper Transfer: Low: 1stSide	*ENG	[0 to 230 / 15 / 1 - μ A /step]
004	Paper Transfer: Low: 2ndSide	*ENG	

2407	[Plain 1: Bias: FC]		
	Adjusts the current for the paper transfer roller for plain 1 paper in full color mode. Standard: 260 mm/sec, Low: 85 mm/sec		
001	Paper Transfer: Standard: 1stSide	*ENG	[0 to 230 / 38 / 1 - μ A /step]
002	Paper Transfer: Standard: 2ndSide	*ENG	[0 to 230 / 40 / 1 - μ A /step]
003	Paper Transfer: Low: 1stSide	*ENG	[0 to 230 / 21 / 1 - μ A /step]
004	Paper Transfer: Low: 2ndSide	*ENG	[0 to 230 / 18 / 1 - μ A /step]

2411	[Plain 1:SizeCorrection:BW]		
	Adjusts the size correction coefficient for the paper transfer roller current for each paper size. SP2403 and SP2407 are multiplied by these SP values. Standard: 260 mm/sec, Low: 85 mm/sec		

001	Paper Transfer: Standard: 1Sid: S1	*ENG	[100 to 995 / 100 / 5%/step] S1 size \geq 194 mm (Paper width)
002	Paper Transfer: Standard: 2Sid: S1	*ENG	
003	Paper Transfer: Low: 1Side: S1	*ENG	
004	Paper Transfer: Low: 2Side S1	*ENG	
005	Paper Transfer: Standard: 1Side: S2	*ENG	[100 to 995 / 135 / 5%/step] 194 mm > S2 size \geq 165 mm (Paper width)
006	Paper Transfer: Standard: 2Side: S2	*ENG	[100 to 995 / 200 / 5%/step] 194 mm > S2 size \geq 165 mm (Paper width)
007	Paper Transfer: Low: 1Side: S2	*ENG	[100 to 995 / 135 / 5%/step] 194 mm > S2 size \geq 165 mm (Paper width)
008	Paper Transfer: Low : 2Side:S2	*ENG	[100 to 995 / 200 / 5%/step] 194 mm > S2 size \geq 165 mm (Paper width)
009	Paper Transfer: Standard: 1Side: S3	*ENG	[100 to 995 / 135 / 5%/step] 165 mm > S3 size \geq 139 mm (Paper width)
010	Paper Transfer: Standard: 2Side: S3	*ENG	[100 to 995 / 390 / 5%/step] 165 mm > S3 size \geq 139 mm (Paper width)
011	Paper Transfer: Low: 1Side: S3	*ENG	[100 to 995 / 135 / 5%/step] 165 mm > S3 size \geq 139 mm (Paper width)
012	Paper Transfer: Low 2Side:S3	*ENG	[100 to 995 / 390 / 5%/step] 165 mm > S3 size \geq 139 mm (Paper width)
013	Paper Transfer: Standard: 1Side: S4	*ENG	[100 to 995 / 220 / 5%/step] 139 mm > S4 size (Paper width)

014	Paper Transfer: Standard: 2Side: S4	*ENG	[100 to 995 / 330 / 5%/step] 139 mm > S4 size (Paper width)
015	PaperTransfer: Low: 1 Side:S4	*ENG	[100 to 995 / 220 / 5%/step] 139 mm > S4 size (Paper width)
016	Paper Transfer: Low 2Side: S4	*ENG	[100 to 995 / 330 / 5%/step] 139 mm > S4 size (Paper width)

2412	[Plain 1:SizeCorrect:FC]		
	Adjusts the size correction coefficient for the paper transfer roller current for each paper size. SP2403 and SP2407 are multiplied by these SP values. Standard: 260 mm/sec, Low: 85 mm/sec		
001	Paper Transfer: Standard: 1Side: S1	*ENG	[100 to 995 / 100 / 5%/step] S1 size ≥ 194 mm (Paper width)
002	Paper Transfer: Standard: 2Side: S1	*ENG	
003	Paper Transfer: Low: 1Side: S1	*ENG	
004	Paper Transfer: Low: 2Side: S1	*ENG	
005	Paper Transfer: Standard: 1Side: S2	*ENG	[100 to 995 / 135 / 5%/step] 194 mm > S2 size ≥ 165 mm (Paper width)
006	Paper Transfer: Standard: 2Side: S2	*ENG	[100 to 995 / 200 / 5%/step] 194 mm > S2 size ≥ 165 mm (Paper width)
007	Paper Transfer: Low: 1Side: S2	*ENG	[100 to 995 / 135 / 5%/step] 194 mm > S2 size ≥ 165 mm (Paper width)
008	Paper Transfer: Low : 2Side:S2	*ENG	[100 to 995 / 200 / 5%/step] 194 mm > S2 size ≥ 165 mm (Paper width)
009	Paper Transfer: Standard: 1Side: S3	*ENG	[100 to 995 / 135 / 5%/step] 165 mm > S3 size ≥ 139 mm (Paper width)

010	Paper Transfer: Standard: 2Side: S3	*ENG	[100 to 995 / 325 / 5%/step] 165 mm > S3 size ≥ 139 mm (Paper width)
011	Paper Transfer: Low: 1Side: S3	*ENG	[100 to 995 / 135 / 5%/step] 165 mm > S3 size ≥ 139 mm (Paper width)
012	Paper Transfer: Low 2Side:S3	*ENG	[100 to 995 / 325 / 5%/step] 165 mm > S3 size ≥ 139 mm (Paper width)
013	Paper Transfer: Standard: 1Side: S4	*ENG	[100 to 995 / 220 / 5%/step] 139 mm > S4 (Paper width)
014	Paper Transfer: Standard: 2Side: S4	*ENG	[100 to 995 / 330 / 5%/step] 139 mm > S4 (Paper width)
015	Paper Transfer: Low: 1Side: S4	*ENG	[100 to 995 / 220 / 5%/step] 139 mm > S4 (Paper width)
016	Paper Transfer: Low: 2Side: S4	*ENG	[100 to 995 / 330 / 5%/step] 139 mm > S4 (Paper width)

2413	[Pain1:Size-Env.Correct:BW]		
	Adjusts the size correction coefficient table for the paper transfer roller current for each paper size. SP2403 and SP2407 are multiplied by these SP values. Standard: 260 mm/sec, Low: 85 mm/sec		
	001	Paper Transfer: Standard: 1Side: S1	*ENG [1 to 100 / 19 / 1/step] S1 size ≥ 194 mm (Paper width)
	002	Paper Transfer: Standard: 2Side: S1	*ENG [1 to 100 / 14 / 1/step] S1 size ≥ 194 mm (Paper width)
	003	Paper Transfer: Low: 1Side: S1	*ENG [1 to 100 / 38 / 1/step] S1 size ≥ 194 mm (Paper width)
004	Paper Transfer: Low: 2Side: S1	*ENG [1 to 100 / 11 / 1/step] S1 size ≥ 194 mm (Paper width)	

005	Paper Transfer: Standard: 1Side: S2	*ENG	[1 to 100 / 19 / 1/step] 194 mm > S2 size ≥ 165 mm (Paper width)
006	Paper Transfer: Standard: 2Side: S2	*ENG	[1 to 100 / 14 / 1/step] 194 mm > S2 size ≥ 165 mm (Paper width)
007	Paper Transfer: Low: 1Side: S2	*ENG	[1 to 100 / 38 / 1/step] 194 mm > S2 size ≥ 165 mm (Paper width)
008	Paper Transfer: Low : 2Side:S2	*ENG	[1 to 100 / 11 / 1/step] 194 mm > S2 size ≥ 165 mm (Paper width)
009	Paper Transfer: Standard: 1Side: S3	*ENG	[1 to 100 / 19 / 1/step] 165 mm > S3 size ≥ 139 mm (Paper width)
010	Paper Transfer: Standard: 2Side: S3	*ENG	[1 to 100 / 6 / 1/step] 165 mm > S3 size ≥ 139 mm (Paper width)
011	Paper Transfer: Low: 1Side: S3	*ENG	[1 to 100 / 38 / 1/step] 165 mm > S3 size ≥ 139 mm (Paper width)
012	Paper Transfer: Low 2Side:S3	*ENG	[1 to 100 / 3 / 1/step] 165 mm > S3 size ≥ 139 mm (Paper width)
013	Paper Transfer: Standard: 1Side: S4	*ENG	[1 to 100 / 19 / 1/step] 139 mm > S4 (Paper width)
014	Paper Transfer: Standard: 2Side: S4	*ENG	[1 to 100 / 14 / 1/step] 139 mm > S4 (Paper width)
015	Paper Transfer: Low: 1Side: S4	*ENG	[1 to 100 / 38 / 1/step] 139 mm > S4 (Paper width)

016	Paper Transfer: Low: 2Side: S4	*ENG	[1 to 100 / 11 / 1/step] 139 mm > S4 (Paper width)
-----	--------------------------------	------	---

System SP2-xxx: 2

SP2-XXX (Drum)

2414	[Pain1:Size-Env.Correct:FC]		
	Adjusts the size correction coefficient table for the paper transfer roller current for each paper size. SP2403 and SP2407 are multiplied by these SP values. Standard: 260 mm/sec, Low: 85 mm/sec		
001	Paper Transfer: Standard: 1Side: S1	*ENG	[1 to 100 / 22 / 1/step] S1 size ≥ 194 mm (Paper width)
002	Paper Transfer: Standard: 2Side: S1	*ENG	[1 to 100 / 17 / 1/step] S1 size ≥ 194 mm (Paper width)
003	Paper Transfer: Low: 1Side: S1	*ENG	[1 to 100 / 35 / 1/step] S1 size ≥ 194 mm (Paper width)
004	Paper Transfer: Low: 2Side: S1	*ENG	[1 to 100 / 33 / 1/step] S1 size ≥ 194 mm (Paper width)
005	Paper Transfer: Standard: 1Side: S2	*ENG	[1 to 100 / 11 / 1/step] 194 mm > S2 size ≥ 165 mm (Paper width)
006	Paper Transfer: Standard: 2Side: S2	*ENG	[1 to 100 / 16 / 1/step] 194 mm > S2 size ≥ 165 mm (Paper width)
007	Paper Transfer: Low: 1Side: S2	*ENG	[1 to 100 / 35 / 1/step] 194 mm > S2 size ≥ 165 mm (Paper width)
008	Paper Transfer: Low : 2Side:S2	*ENG	[1 to 100 / 33 / 1/step] 194 mm > S2 size ≥ 165 mm (Paper width)
009	Paper Transfer: Standard: 1Side: S3	*ENG	[1 to 100 / 11 / 1/step] 165 mm > S3 size ≥ 139 mm (Paper width)

010	Paper Transfer: Standard: 2Side: S3	*ENG	[1 to 100 / 4 / 1/step] 165 mm > S3 size ≥ 139 mm (Paper width)
011	Paper Transfer: Low: 1Side: S3	*ENG	[1 to 100 / 36 / 1/step] 165 mm > S3 size ≥ 139 mm (Paper width)
012	Paper Transfer: Low 2Side:S3	*ENG	[1 to 100 / 77 / 1/step] 165 mm > S3 size ≥ 139 mm (Paper width)
013	Paper Transfer: Standard: 1Side: S4	*ENG	[1 to 100 / 22 / 1/step] 139 mm > S4 (Paper width)
014	Paper Transfer: Standard: 2Side: S4	*ENG	[1 to 100 / 79 / 1/step] 139 mm > S4 (Paper width)
015	Paper Transfer: Low: 1Side: S4	*ENG	[1 to 100 / 35 / 1/step] 139 mm > S4 (Paper width)
016	Paper Transfer: Low: 2Side: S4	*ENG	[1 to 100 / 78 / 1/step] 139 mm > S4 (Paper width)

2421	[Plain 1:L-Edge Correction]
	<p>Adjusts the correction to the paper transfer roller current at the paper leading edge in each mode. SP2403 and SP2407 are multiplied by these SP values. Standard: 260 mm/sec, Low: 85 mm/sec</p> <p>Note</p> <ul style="list-style-type: none"> The paper leading edge area can be adjusted with SP2422.

001	Paper Transfer: Standard: 1Side	*ENG	[0 to 995 / 100 / 5%/step]
002	Paper Transfer: Standard: 2Side	*ENG	
003	Paper Transfer: Low: 1Side	*ENG	
004	Paper Transfer: Low: 2Side	*ENG	
005	Separation DC: Standard: 1Side	*ENG	
006	Separation DC: Standard: 2Side	*ENG	
007	Separation DC: Low: 1Side	*ENG	
008	Separation DC: Low: 2Side	*ENG	

2422	[Plain 1 : Switch Timing: L-Edge]		
	Adjusts the bias/ voltage switch timing of the paper transfer roller/ discharge plate at the paper leading edge between the erase margin area and the image area. Standard: 260 mm/sec, Low: 85 mm/sec		
001	Paper Transfer: Standard: 1Side	*ENG	[0 to 50 / 0 / 2 mm/step]
002	Paper Transfer: Standard: 2Side	*ENG	
003	Paper Transfer: Low: 1Side	*ENG	
004	Paper Transfer: Low: 2Side	*ENG	
005	Separation DC: Standard: 1Side	*ENG	
006	Separation DC: Standard: 2Side	*ENG	
007	Separation DC: Low: 1Side	*ENG	
008	Separation DC: Low: 2Side	*ENG	

2423	[Plain 1: T-Edge Correction]		
	Plain Paper: Trailing Edge Correction		
Adjusts the correction coefficient to the paper transfer roller current for the paper trailing edge in each mode. SP2403 and SP2407 are multiplied by these SP values.			
Standard: 260 mm/sec, Low: 85 mm/sec			
<div style="border: 1px solid blue; border-radius: 15px; padding: 2px; display: inline-block;"> ↓ Note </div> <ul style="list-style-type: none"> The paper trailing edge area can be adjusted with SP2424. 			
001	Paper Transfer: Standard: 1Side	*ENG	[0 to 995 / 100 / 5 %/step]
002	Paper Transfer: Standard: 2Side	*ENG	
003	Paper Transfer: Low: 1Side	*ENG	
004	Paper Transfer: Low: 2Side	*ENG	
005	Separation DC: Standard: 1Side	*ENG	
006	Separation DC: Standard: 2Side	*ENG	
007	Separation DC: Low: 1Side	*ENG	
008	Separation DC: Low: 2Side	*ENG	

2424	[Plain 1: Switch Timing: T-Edge]		
	Adjusts the bias/voltage switch timing of the paper transfer roller/discharge plate at the paper trailing edge between the erase margin area and the image area.		
Standard: 260 mm/sec, Low: 85 mm/sec			
001	Paper Transfer: Standard: 1Side	*ENG	[0 to 50 / 0 / 2 mm/step]
002	Paper Transfer: Standard: 2Side	*ENG	
003	Paper Transfer: Low: 1Side	*ENG	
004	Paper Transfer: Low: 2Side	*ENG	
005	Separation DC: Standard: 1Side	*ENG	
006	Separation DC: Standard: 2Side	*ENG	
007	Separation DC: Low: 1Side	*ENG	
008	Separation DC: Low: 2Side	*ENG	

2425	[HH-Small: L-Edge Correct.]		
001	Paper Transfer: Standard & Low: 1Side	*ENG	[0 to 995 / 100 / 5 %/step]
002	Paper Transfer: Standard & Low: 2Side	*ENG	

2430	[Plain1: Env. Correction]		
013	Table Separation DC: Standard: 1Side	*ENG	[1 to 100 / 30 / 1 /step]
014	Table Separation DC: Standard: 2Side	*ENG	
015	Table Separation DC: Low: 1Side	*ENG	
016	Table Separation DC: Low: 2Side	*ENG	

[Plain: Env. Correction] DFU

017	Edge Separation DC: Standard: 1Side	*ENG	[1 to 100 / 50 / 1 /step]
018	Edge Separation DC: Standard: 2Side	*ENG	
019	Edge Separation DC: Low: 1Side	*ENG	
020	Edge Separation DC: Low: 2Side	*ENG	

2439	[Plain2: Bias]		
	Adjusts the DC voltage of the discharge plate for plain2 paper. Standard: 260 mm/sec, Low: 85mm/sec		
001	Separation DC: Standard Spd: 1Side	*ENG	[0 to 6000 / 2000 / 10 -V/step]
002	Separation DC: Standard Spd: 2Side	*ENG	
003	Separation DC: Low Spd: 1Side	*ENG	
004	Separation DC: Low Spd: 2Side	*ENG	

2440	[Plain2: Bias: BW]		
	Adjusts the current for the paper transfer roller for plain2 paper in black-and-white mode. Standard: 260 mm/sec, Low: 85mm/sec		
001	Paper Transfer: Standard Spd: 1Side	*ENG	[0 to 230 / 21 / 1 - μ A /step]

002	Paper Transfer: Standard Spd: 2Side	*ENG	[0 to 230 / 23 / 1 - μ A /step]
003	Paper Transfer: Low Spd: 1Side	*ENG	[0 to 230 / 15 / 1 - μ A /step]
004	Paper Transfer: Low Spd: 2Side	*ENG	

[Plain2: Bias: FC]			
2441	Adjusts the current for the paper transfer roller for plain2 paper in full color mode. Standard: 260 mm/sec, Low: 85mm/sec		
001	Paper Transfer: Standard Spd: 1Side	*ENG	[0 to 230 / 38 / 1 - μ A /step]
002	Paper Transfer: Standard Spd: 2Side	*ENG	[0 to 230 / 40 / 1 - μ A /step]
003	Paper Transfer: Low Spd: 1Side	*ENG	[0 to 230 / 21 / 1 - μ A /step]
004	Paper Transfer: Low Spd: 2Side	*ENG	[0 to 230 / 18 / 1 - μ A /step]

[Plain2: Size Correction: BW]			
2442	Adjusts the size correction coefficient for the paper transfer roller current for each paper size. SP2440 and SP2441 are multiplied by these SP values. Standard: 260 mm/sec, Low: 85mm/sec		
001	Paper Transfer: Standard: 1Side: S1	*ENG	[100 to 995 / 100 / 5 %/step] S1 size \geq 194 mm (Paper width)
002	Paper Transfer: Standard: 2Side: S1	*ENG	
003	Paper Transfer: Low: 1Side: S1	*ENG	
004	Paper Transfer: Low: 2Side: S1	*ENG	
005	Paper Transfer: Standard: 1Side: S2	*ENG	[100 to 995 / 135 / 5 %/step] 194 mm > S2 size \geq 165 mm (Paper width)
006	Paper Transfer: Standard: 2Side: S2	*ENG	[100 to 995 / 200 / 5 %/step] 194 mm > S2 size \geq 165 mm (Paper width)
007	Paper Transfer: Low: 1Side: S2	*ENG	[100 to 995 / 135 / 5 %/step] 194 mm > S2 size \geq 165 mm (Paper width)

008	Paper Transfer: Low: 2Side: S2	*ENG	[100 to 995 / 200 / 5 %/step] 194 mm > S2 size ≥ 165 mm (Paper width)
009	Paper Transfer: Standard: 1Side: S3	*ENG	[100 to 995 / 135 / 5 %/step] 165 mm > S3 size ≥ 139 mm (Paper width)
010	Paper Transfer: Standard: 2Side: S3	*ENG	[100 to 995 / 390 / 5 %/step] 165 mm > S3 size ≥ 139 mm (Paper width)
011	Paper Transfer: Low: 1Side: S3	*ENG	[100 to 995 / 135 / 5 %/step] 165 mm > S3 size ≥ 139 mm (Paper width)
012	Paper Transfer: Low: 2Side: S3	*ENG	[100 to 995 / 390 / 5 %/step] 165 mm > S3 size ≥ 139 mm (Paper width)
013	Paper Transfer: Standard: 1Side: S4	*ENG	[100 to 995 / 220 / 5 %/step] 139 mm > S4 (Paper width)
014	Paper Transfer: Standard: 2Side: S4	*ENG	[100 to 995 / 330 / 5 %/step] 139 mm > S4 (Paper width)
015	Paper Transfer: Low: 1Side: S4	*ENG	[100 to 995 / 220 / 5 %/step] 139 mm > S4 (Paper width)
016	Paper Transfer: Low: 2Side: S4	*ENG	[100 to 995 / 330 / 5 %/step] 139 mm > S4 (Paper width)

2443	[Plain2: Size Correction: FC]
	Adjusts the size correction coefficient for the paper transfer roller current for each paper size. SP2440 and SP2441 are multiplied by these SP values. Standard: 260 mm/sec, Low: 85mm/sec

001	Paper Transfer: Standard: 1Side: S1	*ENG	[100 to 995 / 100 / 5 %/step] S1 size \geq 194 mm (Paper width)
002	Paper Transfer: Standard: 2Side: S1	*ENG	
003	Paper Transfer: Low: 1Side: S1	*ENG	
004	Paper Transfer: Low: 2Side: S1	*ENG	
005	Paper Transfer: Standard: 1Side: S2	*ENG	[100 to 995 / 135 / 5 %/step] 194 mm > S2 size \geq 165 mm (Paper width)
006	Paper Transfer: Standard: 2Side: S2	*ENG	[100 to 995 / 200 / 5 %/step] 194 mm > S2 size \geq 165 mm (Paper width)
007	Paper Transfer: Low: 1Side: S2	*ENG	[100 to 995 / 135 / 5 %/step] 194 mm > S2 size \geq 165 mm (Paper width)
008	Paper Transfer: Low: 2Side: S2	*ENG	[100 to 995 / 200 / 5 %/step] 194 mm > S2 size \geq 165 mm (Paper width)
009	Paper Transfer: Standard: 1Side: S3	*ENG	[100 to 995 / 135 / 5 %/step] 165 mm > S3 size \geq 139 mm (Paper width)
010	Paper Transfer: Standard: 2Side: S3	*ENG	[100 to 995 / 325 / 5 %/step] 165 mm > S3 size \geq 139 mm (Paper width)
011	Paper Transfer: Low: 1Side: S3	*ENG	[100 to 995 / 135 / 5 %/step] 165 mm > S3 size \geq 139 mm (Paper width)
012	Paper Transfer: Low: 2Side: S3	*ENG	[100 to 995 / 325 / 5 %/step] 165 mm > S3 size \geq 139 mm (Paper width)
013	Paper Transfer: Standard: 1Side: S4	*ENG	[100 to 995 / 220 / 5 %/step] 139 mm > S4 (Paper width)

014	Paper Transfer: Standard: 2Side: S4	*ENG	[100 to 995 / 330 / 5 %/step] 139 mm > S4 (Paper width)
015	Paper Transfer: Low: 1Side: S4	*ENG	[100 to 995 / 220 / 5 %/step] 139 mm > S4 (Paper width)
016	Paper Transfer: Low: 2Side: S4	*ENG	[100 to 995 / 330 / 5 %/step] 139 mm > S4 (Paper width)

2444	[Plain2: Size Env Correct: BW]		
	Adjusts the size correction coefficient table for the paper transfer roller current for each paper size. SP2440 and SP2441 are multiplied by these SP values. Standard: 260 mm/sec, Low: 85mm/sec		
001	Paper Transfer: Standard: 1Side: S1	*ENG	[1 to 100 / 19 / 1 /step] S1 size ≥ 194 mm (Paper width)
002	Paper Transfer: Standard: 2Side: S1	*ENG	[1 to 100 / 8 / 1 /step] S1 size ≥ 194 mm (Paper width)
003	Paper Transfer: Low: 1Side: S1	*ENG	
004	Paper Transfer: Low: 2Side: S1	*ENG	
005	Paper Transfer: Standard: 1Side: S2	*ENG	[1 to 100 / 19 / 1 /step] 194 mm > S2 size ≥ 165 mm (Paper width)
006	Paper Transfer: Standard: 2Side: S2	*ENG	[1 to 100 / 8 / 1 /step] 194 mm > S2 size ≥ 165 mm (Paper width)
007	Paper Transfer: Low: 1Side: S2	*ENG	
008	Paper Transfer: Low: 2Side: S2	*ENG	
009	Paper Transfer: Standard: 1Side: S3	*ENG	[1 to 100 / 19 / 1 /step] 165 mm > S3 size ≥ 139 mm (Paper width)
010	Paper Transfer: Standard: 2Side: S3	*ENG	[1 to 100 / 4 / 1 /step] 165 mm > S3 size ≥ 139 mm (Paper width)

011	Paper Transfer: Low: 1Side: S3	*ENG	[1 to 100 / 8 / 1 /step] 165 mm > S3 size ≥ 139 mm (Paper width)
012	Paper Transfer: Low: 2Side: S3	*ENG	[1 to 100 / 4 / 1 /step] 165 mm > S3 size ≥ 139 mm (Paper width)
013	Paper Transfer: Standard: 1Side: S4	*ENG	[1 to 100 / 19 / 1 /step] 139 mm > S4 (Paper width)
014	Paper Transfer: Standard: 2Side: S4	*ENG	[1 to 100 / 8 / 1 /step]
015	Paper Transfer: Low: 1Side: S4	*ENG	139 mm > S4
016	Paper Transfer: Low: 2Side: S4	*ENG	(Paper width)

2445	[Plain2: Size Env Correct: FC]		
	Adjusts the size correction coefficient table for the paper transfer roller current for each paper size. SP2440 and SP2441 are multiplied by these SP values. Standard: 260 mm/sec, Low: 85mm/sec		
001	Paper Transfer: Standard: 1Side: S1	*ENG	[1 to 100 / 32 / 1 /step] S1 size ≥ 194 mm (Paper width)
002	Paper Transfer: Standard: 2Side: S1	*ENG	[1 to 100 / 39 / 1 /step] S1 size ≥ 194 mm (Paper width)
003	Paper Transfer: Low: 1Side: S1	*ENG	[1 to 100 / 35 / 1 /step] S1 size ≥ 194 mm (Paper width)
004	Paper Transfer: Low: 2Side: S1	*ENG	[1 to 100 / 31 / 1 /step] S1 size ≥ 194 mm (Paper width)
005	Paper Transfer: Standard: 1Side: S2	*ENG	[1 to 100 / 17 / 1 /step] 194 mm > S2 size ≥ 165 mm (Paper width)

006	Paper Transfer: Standard: 2Side: S2	*ENG	[1 to 100 / 38 / 1 /step] 194 mm > S2 size ≥ 165 mm (Paper width)
007	Paper Transfer: Low: 1Side: S2	*ENG	[1 to 100 / 35 / 1 /step] 194 mm > S2 size ≥ 165 mm (Paper width)
008	Paper Transfer: Low: 2Side: S2	*ENG	[1 to 100 / 29 / 1 /step] 194 mm > S2 size ≥ 165 mm (Paper width)
009	Paper Transfer: Standard: 1Side: S3	*ENG	[1 to 100 / 17 / 1 /step] 165 mm > S3 size ≥ 139 mm (Paper width)
010	Paper Transfer: Standard: 2Side: S3	*ENG	[1 to 100 / 16 / 1 /step] 165 mm > S3 size ≥ 139 mm (Paper width)
011	Paper Transfer: Low: 1Side: S3	*ENG	[1 to 100 / 35 / 1 /step] 165 mm > S3 size ≥ 139 mm (Paper width)
012	Paper Transfer: Low: 2Side: S3	*ENG	[1 to 100 / 28 / 1 /step] 165 mm > S3 size ≥ 139 mm (Paper width)
013	Paper Transfer: Standard: 1Side: S4	*ENG	[1 to 100 / 32 / 1 /step] 139 mm > S4 (Paper width)
014	Paper Transfer: Standard: 2Side: S4	*ENG	[1 to 100 / 39 / 1 /step] 139 mm > S4 (Paper width)
015	Paper Transfer: Low: 1Side: S4	*ENG	[1 to 100 / 35 / 1 /step] 139 mm > S4 (Paper width)
016	Paper Transfer: Low: 2Side: S4	*ENG	[1 to 100 / 31 / 1 /step] 139 mm > S4 (Paper width)

2446	[Plain2: L-Edge Correction]		
	Adjusts the correction to the paper transfer roller current at the paper leading edge in each mode. SP2440 and SP2441 are multiplied by these SP values. Standard: 260 mm/sec, Low: 85mm/sec <div style="border: 1px solid blue; border-radius: 15px; padding: 2px; display: inline-block;"> Note </div> <ul style="list-style-type: none"> The paper leading edge area can be adjusted with SP2447. 		
001	Paper Transfer: Standard: 1 Side	*ENG	[0 to 995 / 100 / 5 %/step]
002	Paper Transfer: Standard: 2 Side	*ENG	
003	Paper Transfer: Low: 1 st Side	*ENG	
004	Paper Transfer: Low: 2nd Side	*ENG	
005	Separation DC: Standard: 1st Side	*ENG	
006	Separation DC: Standard: 2nd Side	*ENG	
007	Separation DC: Low: 1 st Side	*ENG	
008	Separation DC: Low: 2nd Side	*ENG	

2447	[Plain2: Switch Timing: L-Edge]		
	Adjusts the bias/ voltage switch timing of the paper transfer roller/ discharge plate at the paper leading edge between the erase margin area and the image area. Standard: 260 mm/sec, Low: 85mm/sec		
001	Paper Transfer: Standard: 1st Side	*ENG	[0 to 50 / 0 / 2 mm/step]
002	Paper Transfer: Standard: 2nd Side	*ENG	
003	Paper Transfer: Low: 1 st Side	*ENG	
004	Paper Transfer: Low: 2 nd Side	*ENG	
005	Separation DC: Standard: 1st Side	*ENG	
006	Separation DC: Standard: 2nd Side	*ENG	
007	Separation DC: Low: 1 st Side	*ENG	
008	Separation DC: Low: 2nd Side	*ENG	

2448	[Plain2: T-Edge Correction]		
	Plain2 Paper: Trailing Edge Correction		
Adjusts the correction coefficient to the paper transfer roller current for the paper trailing edge in each mode. SP2440 and SP2441 are multiplied by these SP values.			
Standard: 260 mm/sec, Low: 85mm/sec			
<div style="border: 1px solid blue; border-radius: 15px; padding: 2px; display: inline-block;"> ↓ Note </div>			
<ul style="list-style-type: none"> The paper trailing edge area can be adjusted with SP2449. 			
001	Paper Transfer: Standard: 1 Side	*ENG	[0 to 995 / 100 / 5 %/step]
002	Paper Transfer: Standard: 2 Side	*ENG	
003	Paper Transfer: Low: 1 st Side	*ENG	
004	Paper Transfer: Low: 2nd Side	*ENG	
005	Separation DC: Standard: 1 st Side	*ENG	
006	Separation DC: Standard: 2nd Side	*ENG	
007	Separation DC: Low: 1 st Side	*ENG	
008	Separation DC: Low: 2nd Side	*ENG	

2449	[Plain2: Switch Timing: T-Edge]		
	Adjusts the bias/voltage switch timing of the paper transfer roller/discharge plate at the paper trailing edge between the erase margin area and the image area.		
Standard: 260 mm/sec, Low: 85mm/sec			
001	Paper Transfer: Standard: 1 st Side	*ENG	[0 to 50 / 0 / 2 mm/step]
002	Paper Transfer: Standard: 2nd Side	*ENG	
003	Paper Transfer: Low: 1 st Side	*ENG	
004	Paper Transfer: Low: 2nd Side	*ENG	
005	Separation DC: Standard: 1 st Side	*ENG	
006	Separation DC: Standard: 2nd Side	*ENG	
007	Separation DC: Low: 1 st Side	*ENG	
008	Separation DC: Low: 2nd Side	*ENG	

2450	[Plain2: Env Correction]		
013	Table Separation DC: Standard: 1st Side	*ENG	[1 to 100 / 30 / 1 /step]
014	Table Separation DC: Standard: 2nd Side	*ENG	
015	Table Separation DC: Low: 1st Side	*ENG	
016	Table Separation DC: Low: 2nd Side	*ENG	
[Plain2: Env Correction]			
017	Edge Separation DC: Standard: 1st Side	*ENG	[1 to 100 / 50 / 1 /step]
018	Edge Separation DC: Standard: 2nd Side	*ENG	
019	Edge Separation DC: Low: 1st Side	*ENG	
020	Edge Separation DC: Low: 2nd Side	*ENG	
2451	[Thin: Bias]		
	Adjusts the DC voltage of the discharge plate for thin paper. Standard: 260 mm/sec, Low: 85 mm/sec		
001	Separation DC: Standard Spd: 1st Side	*ENG	[0 to 6000 / 2000 / 10 -V /step]
003	Separation DC: Low Spd: 1st Side	*ENG	
2453	[Thin: Bias: BW]		
	Adjusts the current for the paper transfer roller for thin paper in black-and-white mode. Standard: 260 mm/sec, Low: 85 mm/sec		
001	Paper Transfer: Standard: 1st Side	*ENG	[0 to 230 / 23 / 1 - μ A /step]
003	Paper Transfer: Low: 1st Side	*ENG	[0 to 230 / 12 / 1 - μ A /step]

2457	[Thin: Bias: FC]		
	Adjusts the current for the paper transfer roller for thin paper in full color mode. Standard: 260 mm/sec, Low: 85 mm/sec		
001	Paper Transfer: Standard: 1st Side	*ENG	[0 to 230 / 29 / 1 –μA /step]
003	Paper Transfer: Low: 1st Side	*ENG	[0 to 230 / 18 / 1 –μA /step]

2461	[Thin: Paper Size Correction: BW]		
	Adjusts the size correction coefficient for the paper transfer roller current for each paper size. SP2453 and SP2457 are multiplied by these SP values. Standard: 260 mm/sec, Low: 85mm/sec		
001	Paper Transfer: Standard: 1Side: S1	*ENG	[100 to 995 / 100 / 5% /step] S1 size ≥ 194 mm (Paper width)
003	Paper Transfer: Low: 1 Side: S1	*ENG	[100 to 995 / 100 / 5% /step] S1 size ≥ 194 mm (Paper width)
005	Paper Transfer: Standard: 1Side: S2	*ENG	[100 to 995 / 135 / 5% /step] 194 mm > S2 size ≥ 165 mm (Paper width)
007	Paper Transfer: Low: 1 Side: S2	*ENG	[100 to 995 / 135 / 5% /step] 194 mm > S2 size ≥ 165 mm (Paper width)
009	Paper Transfer: Standard: 1Side: S3	*ENG	[100 to 600 / 135 / 5% /step] 165 mm > S3 size ≥ 139 mm (Paper width)
011	Paper Transfer: Low: 1 Side: S3	*ENG	[100 to 995 / 135 / 5% /step] 165 mm > S3 size ≥ 139 mm (Paper width)
013	Paper Transfer: Standard: 1Side: S4	*ENG	[100 to 995 / 220 / 5% /step] 139 mm > S4 (Paper width)
015	Paper Transfer: Low: 1 Side: S4	*ENG	[100 to 995 / 220 / 5% /step] 139 mm > S4 (Paper width)

2462	[Thin: Size Correct: FC]		
	Adjusts the size correction coefficient for the paper transfer roller current for each paper size. SP2453 and SP2457 are multiplied by these SP values. Standard: 260 mm/sec, Low: 85mm/sec		
001	Paper Transfer: Standard: 1 Side: S1	*ENG	[100 to 995 / 100 / 5% /step]
003	Paper Transfer: Low: 1 Side: S1	*ENG	S1 size ≥ 194 mm (Paper width)
005	Paper Transfer: Standard: 1 Side: S2	*ENG	[100 to 995 / 135 / 5% /step]
007	Paper Transfer: Low: 1 Side: S2	*ENG	194 mm > S2 size ≥ 165 mm (Paper width)
009	Paper Transfer: Standard: 1 Side: S3	*ENG	[100 to 995 / 135 / 5% /step]
011	Paper Transfer: Low: 1 Side: S3	*ENG	165 mm > S3 size ≥ 139 mm (Paper width)
013	Paper Transfer: Standard: 1 Side: S4	*ENG	[100 to 995 / 220 / 5% /step]
015	Paper Transfer: Low: 1 Side: S4	*ENG	139 mm > S4 (Paper width)

2463	[Thin: Size Env Correct: BW]		
	Adjusts the size correction coefficient table for the paper transfer roller current for each paper size. SP2453 and SP2457 are multiplied by these SP values. Standard: 260 mm/sec, Low: 85mm/sec		
001	Paper Transfer: Standard: 1 Side: S1	*ENG	[1 to 100 / 16 / 1 /step] S1 size ≥ 194 mm (Paper width)
003	Paper Transfer: Low: 1 Side: S1	*ENG	[1 to 100 / 21 / 1 /step] S1 size ≥ 194 mm (Paper width)
005	Paper Transfer: Standard: 1 Side: S2	*ENG	[1 to 100 / 8 / 1 /step] 194 mm > S2 size ≥ 165 mm (Paper width)
007	Paper Transfer: Low: 1 Side: S2	*ENG	[1 to 100 / 21 / 1 /step] 194 mm > S2 size ≥ 165 mm (Paper width)

009	Paper Transfer: Standard: 1Side: S3	*ENG	[1 to 100 / 8 / 1 /step] 165 mm > S3 size ≥ 139 mm (Paper width)
011	Paper Transfer: Low: 1 Side: S3	*ENG	[1 to 100 / 21 / 1 /step] 165 mm > S3 size ≥ 139 mm (Paper width)
013	Paper Transfer: Standard: 1Side: S4	*ENG	[1 to 100 / 16 / 1 /step] 139 mm > S4 (Paper width)
015	Paper Transfer: Low: 1 Side: S4	*ENG	[1 to 100 / 21 / 1 /step] 139 mm > S4 (Paper width)

2464	[Thin: Size Env Correct: FC]		
	Adjusts the size correction coefficient table for the paper transfer roller current for each paper size. SP2453 and SP2457 are multiplied by these SP values. Standard: 260 mm/sec, Low: 85mm/sec		
001	Paper Transfer: Standard: 1Side: S1	*ENG	[1 to 100 / 9 / 1 /step] S1 size ≥ 194 mm (Paper width)
003	Paper Transfer: Low: 1 Side: S1	*ENG	[1 to 100 / 26 / 1 /step] S1 size ≥ 194 mm (Paper width)
005	Paper Transfer: Standard: 1Side: S2	*ENG	[1 to 100 / 9 / 1 /step] 194 mm > S2 size ≥ 165 mm (Paper width)
007	Paper Transfer: Low: 1 Side: S2	*ENG	[1 to 100 / 26 / 1 /step] 194 mm > S2 size ≥ 165 mm (Paper width)
009	Paper Transfer: Standard: 1Side: S3	*ENG	[1 to 100 / 9 / 1 /step] 165 mm > S3 size ≥ 139 mm (Paper width)
011	Paper Transfer: Low: 1 Side: S3	*ENG	[1 to 100 / 26 / 1 /step] 165 mm > S3 size ≥ 139 mm (Paper width)

013	Paper Transfer: Standard: 1 Side: S4	*ENG	[1 to 100 / 9 / 1 /step] 139 mm > S4 (Paper width)
015	Paper Transfer: Low: 1 Side: S4	*ENG	[1 to 100 / 26 / 1 /step] 139 mm > S4 (Paper width)

2471	[Thin: Leading Edge Correction] Thin Paper: Leading Edge Correction		
	Adjusts the correction to the paper transfer roller current at the paper leading edge in each mode. SP2453 and SP2457 are multiplied by these SP values. Standard: 260 mm/sec, Low: 85 mm/sec		
	<div style="border: 1px solid blue; border-radius: 10px; padding: 2px; display: inline-block;"> Note </div> <ul style="list-style-type: none"> The paper leading edge area can be adjusted with SP2472. 		
001	Paper Transfer: Standard: 1st Side	*ENG	[0 to 995 / 100 / 5%/step]
003	Paper Transfer: Low: 1st Side	*ENG	
005	Separation DC: Standard: 1st Side	*ENG	[0 to 995 / 200 / 5%/step]
007	Separation DC: Low: 1st Side	*ENG	

2472	[Thin: Switch Timing: Lead. Edge]		
	Adjusts the bias/ voltage switch timing of the paper transfer roller/ discharge plate at the paper leading edge between the erase margin area and the image area. Standard: 260 mm/sec, Low: 85 mm/sec		
001	Paper Transfer: Standard: 1st Side	*ENG	[0 to 50 / 0 / 2 mm/step]
003	Paper Transfer: Low: 1st Side	*ENG	
005	Separation DC: Standard: 1st Side	*ENG	[0 to 50 / 30 / 2 mm/step]
007	Separation DC: Low: 1st Side	*ENG	

2473	[Thin: Trailing Edge Correction] Thin Paper: Trailing Edge Correction		
	Adjusts the correction coefficient to the paper transfer roller current for the paper trailing edge in each mode. SP2453 and SP2457 are multiplied by these SP values. Standard: 260 mm/sec, Low: 85 mm/sec		
	<div style="border: 1px solid blue; border-radius: 15px; padding: 2px; display: inline-block;"> ↓ Note </div> <ul style="list-style-type: none"> The paper trailing edge area can be adjusted with SP2474. 		
001	Paper Transfer: Standard: 1st Side	*ENG	[0 to 995 / 100 / 5%/step]
003	Paper Transfer: Low: 1st Side	*ENG	
005	Separation DC: Standard: 1st Side	*ENG	
007	Separation DC: Low: 1st Side	*ENG	

2474	[Thin: Switch Timing: Trail. Edge]		
	Adjusts the bias/voltage switch timing of the paper transfer roller/discharge plate at the paper trailing edge between the erase margin area and the image area. Standard: 260 mm/sec, Low: 85 mm/sec		
001	Paper Transfer: Standard: 1st Side	*ENG	[0 to 50 / 0 / 2 mm/step]
003	Paper Transfer: Low: 1st Side	*ENG	
005	Separation DC: Standard: 1st Side	*ENG	
007	Separation DC: Low: 1st Side	*ENG	

System SP2-xxx: 3

SP2-XXX (Drum)

2480	[Thin: Environment Correction Table] Standard: 260 mm/sec, Low: 85 mm/sec		
013	Separation DC: Standard: 1st Side	*ENG	[1 to 100 / 30 / 1 /step]
015	Separation DC: Low: 1st Side	*ENG	
[Thin: Edge Env. Correct]			
017	Separation DC: Standard: 1st Side	*ENG	[1 to 100 / 30 / 1 /step]
019	Separation DC: Low: 1st Side	*ENG	

2501	[Thick1: Bias] Adjusts the DC voltage of the discharge plate for thick 1 paper. Middle: 182 mm/sec, Low: 85 mm/sec		
001	Separation DC: Middle Speed: 1st Side	*ENG	[0 to 6000 / 2000 / 10 -V / step]
002	Separation DC: Middle Speed: 2nd Side	*ENG	
003	Separation DC: Low Speed: 1st Side	*ENG	
004	Separation DC: Low Speed: 2nd Side	*ENG	

2502	[Thick 1: Bias: BW] Adjusts the current for the paper transfer roller for thick 1 paper in black-and-white mode. Middle: 182 mm/sec, Low: 85 mm/sec		
001	Paper Transfer: Middle Speed: 1st Side	*ENG	[0 to 230 / 15 / 1 - μ A /step]
002	Paper Transfer: Middle Speed: 2nd Side	*ENG	[0 to 230 / 15 / 1 - μ A /step]
003	Paper Transfer: Low Speed: 1st Side	*ENG	[0 to 230 / 9 / 1 - μ A /step]

004	Paper Transfer: Low Speed: 2nd Side	*ENG	[0 to 230 / 12 / 1 – μ A /step]
-----	-------------------------------------	------	--

2507	[Thick 1: Bias: FC]		
	Adjusts the current for the paper transfer roller for thick 1 paper in full color mode. Middle: 182 mm/sec, Low: 85 mm/sec		
001	Paper Transfer: Middle Speed: 1st Side	*ENG	[0 to 230 / 24 / 1 – μ A /step]
002	Paper Transfer: Middle Speed: 2nd Side	*ENG	[0 to 230 / 24 / 1 – μ A /step]
003	Paper Transfer: Low Speed: 1st Side	*ENG	[0 to 230 / 12 / 1 – μ A /step]
004	Paper Transfer: Low Speed: 2nd Side	*ENG	[0 to 230 / 18 / 1 – μ A /step]

5

2511	[Thick1: Size Correction: BW]		
	Adjusts the size correction coefficient for the paper transfer roller current for each paper size. SP2502 and SP2507 are multiplied by these SP values. Middle: 182 mm/sec, Low: 85 mm/sec		
001	Paper Transfer: Middle: 1Side: S1	*ENG	[100 to 995 / 100 / 5%/step]
002	Paper Transfer: Middle: 2Side: S1	*ENG	S1 size \geq 194 mm (Paper width)
003	Paper Transfer: Low: 1 Side: S1	*ENG	[100 to 995 / 100 / 5%/step]
004	Paper Transfer: Low: 2 Side: S1	*ENG	S1 size \geq 194 mm (Paper width)
005	Paper Transfer: Middle: 1Side: S2	*ENG	[100 to 995 / 150 / 5%/step] 194 mm > S2 size \geq 165 mm (Paper width)
006	Paper Transfer: Middle: 2Side: S2	*ENG	[100 to 995 / 160 / 5%/step] 194 mm > S2 size \geq 165 mm (Paper width)
007	Paper Transfer: Low: 1 Side: S2	*ENG	[100 to 995 / 150 / 5%/step] 194 mm > S2 size \geq 165 mm (Paper width)

008	Paper Transfer: Low: 2 Side: S2	*ENG	[100 to 995 / 160 / 5%/step] 194 mm > S2 size ≥ 165 mm (Paper width)
009	Paper Transfer: Middle: 1Side: S3	*ENG	[100 to 995 / 150 / 5%/step] 165 mm > S3 size ≥ 139 mm (Paper width)
010	Paper Transfer: Middle: 2Side: S3	*ENG	[100 to 995 / 270 / 5%/step] 165 mm > S3 size ≥ 139 mm (Paper width)
011	Paper Transfer: Low: 1 Side: S3	*ENG	[100 to 995 / 150 / 5%/step] 165 mm > S3 size ≥ 139 mm (Paper width)
012	Paper Transfer: Low: 2 Side: S3	*ENG	[100 to 995 / 270 / 5%/step] 165 mm > S3 size ≥ 139 mm (Paper width)
013	Paper Transfer: Middle: 1Side: S4	*ENG	[100 to 995 / 200 / 5%/step] 139 mm > S4 (Paper width)
014	Paper Transfer: Middle: 2Side: S4	*ENG	[100 to 995 / 435 / 5%/step] 139 mm > S4 (Paper width)
015	Paper Transfer: Low: 1: S4	*ENG	[100 to 995 / 200 / 5%/step] 139 mm > S4 (Paper width)
016	Paper Transfer: Low: 2: S4	*ENG	[100 to 995 / 435 / 5%/step] 139 mm > S4 (Paper width)

2512	[Thick1: Size Correction: FC]
	Adjusts the size correction coefficient for the paper transfer roller current for each paper size. SP2502 and SP2507 are multiplied by these SP values. Middle: 182 mm/sec, Low: 85 mm/sec

001	Paper Transfer: Middle: 1Side: S1	*ENG	[100 to 995 / 100 / 5%/step] S1 size \geq 194 mm (Paper width)
002	Paper Transfer: Middle: 2Side: S1	*ENG	
003	Paper Transfer: Low: 1Side: S1	*ENG	
004	Paper Transfer: Low: 2: S1	*ENG	
005	Paper Transfer: Middle: 1Side: S2	*ENG	[100 to 995 / 150 / 5%/step] 194 mm > S2 size \geq 165 mm (Paper width)
006	Paper Transfer: Middle: 2Side: S2	*ENG	[100 to 995 / 160 / 5%/step] 194 mm > S2 size \geq 165 mm (Paper width)
007	Paper Transfer: Low: 1 Side: S2	*ENG	[100 to 995 / 150 / 5%/step] 194 mm > S2 size \geq 165 mm (Paper width)
008	Paper Transfer: Low: 2 Side: S2	*ENG	[100 to 995 / 160 / 5%/step] 194 mm > S2 size \geq 165 mm (Paper width)
009	Paper Transfer: Middle: 1Side: S3	*ENG	[100 to 995 / 150 / 5%/step] 165 mm > S3 size \geq 139 mm (Paper width)
010	Paper Transfer: Middle: 2Side: S3	*ENG	[100 to 995 / 270 / 5%/step] 165 mm > S3 size \geq 139 mm (Paper width)
011	Paper Transfer: Low: 1 Side: S3	*ENG	[100 to 995 / 150 / 5%/step] 165 mm > S3 size \geq 139 mm (Paper width)
012	Paper Transfer: Low: 2 Side: S3	*ENG	[100 to 995 / 270 / 5%/step] 165 mm > S3 size \geq 139 mm (Paper width)
013	Paper Transfer: Middle: 1Side: S4	*ENG	[100 to 995 / 200 / 5%/step] 139 mm > S4 (Paper width)

014	Paper Transfer: Middle: 2Side: S4	*ENG	[100 to 995 / 435 / 5%/step] 139 mm > S4 (Paper width)
015	Paper Transfer: Low: 1 Side: S4	*ENG	[100 to 995 / 200 / 5%/step] 139 mm > S4 (Paper width)
016	Paper Transfer: Low: 2 Side: S4	*ENG	[100 to 995 / 435 / 5%/step] 139 mm > S4 (Paper width)

2513	[Thick1:Size-Env.Correct:BW]		
	Adjusts the size correction coefficient table for the paper transfer roller current for each paper size. SP2502 and SP2507 are multiplied by these SP values. Middle: 182 mm/sec, Low: 85 mm/sec		
001	Paper Transfer: Middle: 1st Side: S1	*ENG	[1 to 100 / 20 / 1/step] S1 size ≥ 194 mm (Paper width)
002	Paper Transfer: Middle: 2nd Side: S1	*ENG	[1 to 100 / 19 / 1/step] S1 size ≥ 194 mm (Paper width)
003	Paper Transfer: Low: 1 Side: S1	*ENG	[1 to 100 / 18 / 1/step] S1 size ≥ 194 mm (Paper width)
004	Paper Transfer: Low: 2 Side: S1	*ENG	[1 to 100 / 23 / 1/step] S1 size ≥ 194 mm (Paper width)
005	Paper Transfer: Middle: 1st Side: S2	*ENG	[1 to 100 / 20 / 1/step] 194 mm > S2 size ≥ 165 mm (Paper width)
006	Paper Transfer: Middle: 2nd Side: S2	*ENG	[1 to 100 / 19 / 1/step] 194 mm > S2 size ≥ 165 mm (Paper width)
007	Paper Transfer: Low: 1 Side: S2	*ENG	[1 to 100 / 18 / 1/step] 194 mm > S2 size ≥ 165 mm (Paper width)

008	Paper Transfer: Low: 2 Side: S2	*ENG	[1 to 100 / 23 / 1/step] 194 mm > S2 size ≥ 165 mm (Paper width)
009	Paper Transfer: Middle: 1st Side: S3	*ENG	[1 to 100 / 20 / 1/step] 165 mm > S3 size ≥ 139 mm (Paper width)
010	Paper Transfer: Middle: 2nd Side: S3	*ENG	[1 to 100 / 19 / 1/step] 165 mm > S3 size ≥ 139 mm (Paper width)
011	Paper Transfer: Low: 1 Side: S3	*ENG	[1 to 100 / 18 / 1/step] 165 mm > S3 size ≥ 139 mm (Paper width)
012	Paper Transfer: Low: 2 Side: S3	*ENG	[1 to 100 / 23 / 1/step] 165 mm > S3 size ≥ 139 mm (Paper width)
013	Paper Transfer: Middle: 1st Side: S4	*ENG	[1 to 100 / 20 / 1/step] 139 mm > S4 (Paper width)
014	Paper Transfer: Middle: 2nd Side: S4	*ENG	[1 to 100 / 19 / 1/step] 139 mm > S4 (Paper width)
015	Paper Transfer: Low: 1 Side: S4	*ENG	[1 to 100 / 18 / 1/step] 139 mm > S4 (Paper width)
016	Paper Transfer: Low: 2 Side: S4	*ENG	[1 to 100 / 23 / 1/step] 139 mm > S4 (Paper width)

2514	[Thick1:Size-Env.Correct:FC]		
	Adjusts the size correction coefficient table for the paper transfer roller current for each paper size. SP2502 and SP2507 are multiplied by these SP values. Middle: 182 mm/sec, Low: 85 mm/sec		
001	Paper Transfer: Middle: 1st Side: S1	*ENG	[1 to 100 / 2 / 1/step] S1 size ≥ 194 mm (Paper width)

002	Paper Transfer: Middle: 2nd Side: S1	*ENG	[1 to 100 / 31 / 1/step] S1 size \geq 194 mm (Paper width)
003	Paper Transfer: Low: 1 Side: S1	*ENG	[1 to 100 / 13 / 1/step] S1 size \geq 194 mm (Paper width)
004	Paper Transfer: Low: 2 Side: S1	*ENG	[1 to 100 / 25 / 1/step] S1 size \geq 194 mm (Paper width)
005	Paper Transfer: Middle: 1st Side: S2	*ENG	[1 to 100 / 2 / 1/step] 194 mm > S2 size \geq 165 mm (Paper width)
006	Paper Transfer: Middle: 2nd Side: S2	*ENG	[1 to 100 / 31 / 1/step] 194 mm > S2 size \geq 165 mm (Paper width)
007	Paper Transfer: Low: 1 Side: S2	*ENG	[1 to 100 / 13 / 1/step] 194 mm > S2 size \geq 165 mm (Paper width)
008	Paper Transfer: Low: 2 Side: S2	*ENG	[1 to 100 / 25 / 1/step] 194 mm > S2 size \geq 165 mm (Paper width)
009	Paper Transfer: Middle: 1st Side: S3	*ENG	[1 to 100 / 2 / 1/step] 165 mm > S3 size \geq 139 mm (Paper width)
010	Paper Transfer: Middle: 2nd Side: S3	*ENG	[1 to 100 / 31 / 1/step] 165 mm > S3 size \geq 139 mm (Paper width)
011	Paper Transfer: Low: 1 Side: S3	*ENG	[1 to 100 / 13 / 1/step] 165 mm > S3 size \geq 139 mm (Paper width)
012	Paper Transfer: Low: 2 Side: S3	*ENG	[1 to 100 / 25 / 1/step] 165 mm > S3 size \geq 139 mm (Paper width)

013	Paper Transfer: Middle: 1st Side: S4	*ENG	[1 to 100 / 2 / 1/step] 139 mm > S4 (Paper width)
014	Paper Transfer: Middle: 2nd Side: S4	*ENG	[1 to 100 / 31 / 1/step] 139 mm > S4 (Paper width)
015	Paper Transfer: Low: 1 Side: S4	*ENG	[1 to 100 / 13 / 1/step] 139 mm > S4 (Paper width)
016	Paper Transfer: Low: 2 Side: S4	*ENG	[1 to 100 / 25 / 1/step] 139 mm > S4 (Paper width)

2521	[Thick 1:L-Edge Correction]			
	Thick 1 Paper: Leading Edge Correction			
	Adjusts the correction to the paper transfer roller current at the paper leading edge in each mode. SP2502 and SP2507 are multiplied by these SP values. Middle: 182 mm/sec, Low: 85 mm/sec			
	 Note			
	<ul style="list-style-type: none"> The paper leading edge area can be adjusted with SP2522. 			
	001	Paper Transfer: Middle: 1 Side	*ENG	[0 to 995 / 100 / 5%/step]
	002	Paper Transfer: Middle: 2 Side	*ENG	
	003	Paper Transfer: Low: 1st Side	*ENG	
	004	Paper Transfer: Low: 2nd Side	*ENG	
005	Separation DC: Middle: 1st Side	*ENG		
006	Separation DC: Middle: 2nd Side	*ENG		
007	Separation DC: Low: 1st Side	*ENG		
008	Separation DC: Low: 2nd Side	*ENG		

2522	[Thick 1: Switch Timing: L-Edge]		
	Adjusts the bias/ voltage switch timing of the paper transfer roller/ discharge plate at the paper leading edge between the erase margin area and the image area. Middle: 182 mm/sec, Low: 85 mm/sec		

001	Paper Transfer: 1st Side	*ENG	[0 to 50 / 0 / 2 mm/step]
002	Paper Transfer: 2nd Side	*ENG	
003	Paper Transfer: Low: 1st Side	*ENG	
004	Paper Transfer: Low: 2nd Side	*ENG	
005	Separation DC: Middle: 1st Side	*ENG	
006	Separation DC: Middle: 2nd Side	*ENG	
007	Separation DC: Low: 1st Side	*ENG	
008	Separation DC: Low: 2nd Side	*ENG	

5

2523	[Thick 1: T-Edge Correction]		[0 to 995 / 100 / 5%/step]	
	Thick 1 Paper: Trailing Edge Correction			
	Adjusts the correction coefficient to the paper transfer roller current for the paper trailing edge in each mode. SP2502 and SP2507 are multiplied by these SP values. Middle: 182 mm/sec, Low: 85 mm/sec			
	 Note			
	<ul style="list-style-type: none"> The paper trailing edge area can be adjusted with SP2524. 			
	001	Paper Transfer: 1st Side		*ENG
	002	Paper Transfer: 2nd Side		*ENG
	003	Paper Transfer: Low: 1st Side		*ENG
	004	Paper Transfer: Low: 2nd Side		*ENG
005	Separation DC: Middle: 1st Side	*ENG		
006	Separation DC: Middle: 2nd Side	*ENG		
007	Separation DC: Low: 1st Side	*ENG		
008	Separation DC: Low: 2nd Side	*ENG		

2524	[Thick 1: Switch Timing: T-Edge]		
	Adjusts the bias/voltage switch timing of the paper transfer roller/discharge plate at the paper trailing edge between the erase margin area and the image area. Middle: 182 mm/sec, Low: 85 mm/sec		
001	Paper Transfer: Middle: 1st Side	*ENG	[0 to 50 / 0 / 2 mm/step]
002	Paper Transfer: Middle: 2nd Side	*ENG	
003	Paper Transfer: Low: 1st Side	*ENG	
004	Paper Transfer: Low: 2nd Side	*ENG	
005	Separation DC: Middle: 1st Side	*ENG	
006	Separation DC: Middle: 2nd Side	*ENG	
007	Separation DC: Low: 1st Side	*ENG	
008	Separation DC: Low: 2nd Side	*ENG	

2530	[Thick 1: Env. Correction Table]		
013	Separation DC: Middle: 1st Side	*ENG	[1 to 100 / 30 / 1 /step]
014	Separation DC: Middle: 2nd Side	*ENG	
015	Separation DC: Low: 1st Side	*ENG	
016	Separation DC: Low: 2nd Side	*ENG	
[Thick 1: Edge-Env. Correct] DFU			
017	Separation DC: Middle: 1st Side	*ENG	[1 to 100 / 30 / 1 /step]
018	Separation DC: Middle: 2nd Side	*ENG	
019	Separation DC: Low: 1st Side	*ENG	
020	Separation DC: Low: 2nd Side	*ENG	

2551	[Thick2: Bias]		
	Adjusts the DC voltage of the discharge plate for thick 2 paper.		

003	Separation DC: 1st Side	*ENG	[0 to 6000 / 2000 / 10 -V/step]
004	Separation DC: 2nd Side	*ENG	

2553	[Thick 2: Bias: BW]		
	Adjusts the current for the paper transfer roller for thick2 paper in black-and-white mode.		
001	Paper Transfer: 1st Side	*ENG	[0 to 230 / 9 / 1 -μA /step]
002	Paper Transfer: 2nd Side	*ENG	[0 to 230 / 12 / 1 -μA /step]

2558	[Thick 2: Bias: FC]		
	Adjusts the current for the paper transfer roller for thick2 paper in full color mode.		
001	Paper Transfer: 1st Side	*ENG	[0 to 230 / 12 / 1 -μA /step]
002	Paper Transfer: 2nd Side	*ENG	[0 to 230 / 20 / 1 -μA /step]

2561	[Thick 2: Size Correction: BW]		
	Adjusts the size correction coefficient for the paper transfer roller current for each paper size. SP2553 and SP2558 are multiplied by these SP values.		
003	Paper Transfer: 1 Side: S1	*ENG	[100 to 995 / 100 / 5% /step] S1 size ≥ 194 mm (Paper width)
004	Paper Transfer: 2 Side: S1	*ENG	[100 to 995 / 100 / 5% /step] S1 size ≥ 194 mm (Paper width)
007	Paper Transfer: 1 Side: S2	*ENG	[100 to 995 / 150 / 5% /step] 194 mm > S2 size ≥ 165 mm (Paper width)
008	Paper Transfer: 2 Side: S2	*ENG	[100 to 995 / 160 / 5% /step] 194 mm > S2 size ≥ 165 mm (Paper width)
011	Paper Transfer: 1 Side: S3	*ENG	[100 to 995 / 150 / 5% /step] 165 mm > S3 size ≥ 139 mm (Paper width)

012	Paper Transfer: 2 Side: S3	*ENG	[100 to 995 / 270 / 5% /step] 165 mm > S3 size ≥ 139 mm (Paper width)
015	Paper Transfer: 1 Side: S4	*ENG	[100 to 995 / 200 / 5% /step] 139 mm > S4 (Paper width)
016	Paper Transfer: 2 Side: S4	*ENG	[100 to 995 / 435 / 5% /step] 139 mm > S4 (Paper width)

2562	[Thick 2: Size Correction: FC]		
	Adjusts the size correction coefficient for the paper transfer roller current for each paper size. SP2553 and SP2558 are multiplied by these SP values.		
003	Paper Transfer: 1 Side: S1	*ENG	[100 to 995 / 100 / 5% /step]
004	Paper Transfer: 2 Side: S1	*ENG	S1 size ≥ 194 mm (Paper width)
007	Paper Transfer: 1 Side: S2	*ENG	[100 to 995 / 150 / 5% /step] 194 mm > S2 size ≥ 165 mm (Paper width)
008	Paper Transfer: 2 Side: S2	*ENG	[100 to 995 / 160 / 5% /step] 194 mm > S2 size ≥ 165 mm (Paper width)
011	Paper Transfer: 1 Side: S3	*ENG	[100 to 995 / 150 / 5% /step] 165 mm > S3 size ≥ 139 mm (Paper width)
012	Paper Transfer: 2 Side: S3	*ENG	[100 to 995 / 270 / 5% /step] 165 mm > S3 size ≥ 139 mm (Paper width)
015	Paper Transfer: 1 Side: S4	*ENG	[100 to 995 / 200 / 5% /step] 139 mm > S4 (Paper width)
016	Paper Transfer: 2 Side: S4	*ENG	[100 to 995 / 435 / 5% /step] 139 mm > S4 (Paper width)

[Thick 2: Size Env. Correct.: BW]			
2563	Adjusts the size correction coefficient table for the paper transfer roller current for each paper size. SP2553 and SP2558 are multiplied by these SP values.		
003	Paper Transfer: 1 Side: S1	*ENG	[1 to 100 / 18 / 1 /step] S1 size ≥ 194 mm (Paper width)
004	Paper Transfer: 2 Side: S1	*ENG	[1 to 100 / 22 / 1 /step] S1 size ≥ 194 mm (Paper width)
007	Paper Transfer: 1 Side: S2	*ENG	[1 to 100 / 18 / 1 /step] 194 mm > S2 size ≥ 165 mm (Paper width)
008	Paper Transfer: 2 Side: S2	*ENG	[1 to 100 / 22 / 1 /step] 194 mm > S2 size ≥ 165 mm (Paper width)
011	Paper Transfer: 1 Side: S3	*ENG	[1 to 100 / 18 / 1 /step] 165 mm > S3 size ≥ 139 mm (Paper width)
012	Paper Transfer: 2 Side: S3	*ENG	[1 to 100 / 22 / 1 /step] 165 mm > S3 size ≥ 139 mm (Paper width)
015	Paper Transfer: 1 Side: S4	*ENG	[1 to 100 / 18 / 1 /step] 139 mm > S4 (Paper width)
016	Paper Transfer: 2 Side: S4	*ENG	[1 to 100 / 22 / 1 /step] 139 mm > S4 (Paper width)

[Thick 2: Size Env. Correct.: FC]			
2564	Adjusts the size correction coefficient table for the paper transfer roller current for each paper size. SP2553 and SP2558 are multiplied by these SP values.		
003	Paper Transfer: 1 Side: S1	*ENG	[1 to 100 / 13 / 1 /step] S1 size ≥ 194 mm (Paper width)

004	Paper Transfer: 2 Side: S1	*ENG	[1 to 100 / 38 / 1 /step] S1 size \geq 194 mm (Paper width)
007	Paper Transfer: 1 Side: S2	*ENG	[1 to 100 / 13 / 1 /step] 194 mm > S2 size \geq 165 mm (Paper width)
008	Paper Transfer: 2 Side: S2	*ENG	[1 to 100 / 38 / 1 /step] 194 mm > S2 size \geq 165 mm (Paper width)
011	Paper Transfer: 1 Side: S3	*ENG	[1 to 100 / 13 / 1 /step] 165 mm > S3 size \geq 139 mm (Paper width)
012	Paper Transfer: 2 Side: S3	*ENG	[1 to 100 / 38 / 1 /step] 165 mm > S3 size \geq 139 mm (Paper width)
015	Paper Transfer: 1 Side: S4	*ENG	[1 to 100 / 13 / 1 /step] 139 mm > S4 (Paper width)
016	Paper Transfer: 2 Side: S4	*ENG	[1 to 100 / 38 / 1 /step] 139 mm > S4 (Paper width)

2571	[Thick 2: L-Edge Correction]		
	Thick 2 Paper: Leading Edge Correction		
	Adjusts the correction to the paper transfer roller current at the paper leading edge in each mode. SP2553 and SP2558 are multiplied by these SP values.		
	<div style="border: 1px solid blue; border-radius: 10px; padding: 2px; display: inline-block;">  Note </div>		
	<ul style="list-style-type: none"> The paper leading edge area can be adjusted with SP2572. 		
001	Paper Transfer: 1st Side	*ENG	[0 to 995 / 100 / 5%/step]
002	Paper Transfer: 2nd Side	*ENG	
003	Separation DC: 1st Side	*ENG	
004	Separation DC: 2nd Side	*ENG	

2572	[Thick 2: Switch Timing: L-Edge]		
	Adjusts the bias/ voltage switch timing of the paper transfer roller/ discharge plate at the paper leading edge between the erase margin area and the image area.		
001	Paper Transfer: 1st Side	* ENG	[0 to 50 / 0 / 2mm/step]
002	Paper Transfer: 2nd Side	* ENG	
003	Separation DC: 1st Side	* ENG	
004	Separation DC: 2nd Side	* ENG	

2573	[Thick 2: T-Edge Correction]		
	Thick 2 Paper: Trailing Edge Correction		
Adjusts the correction to the paper transfer roller current for the paper trailing edge in each mode. SP2553 and SP2558 are multiplied by these SP values.			
<p>Note</p> <ul style="list-style-type: none"> The paper trailing edge area can be adjusted with SP2574. 			
001	Paper Transfer: 1st Side	* ENG	[0 to 995 / 100 / 5%/step]
002	Paper Transfer: 2nd Side	* ENG	
003	Separation DC: 1st Side	* ENG	
004	Separation DC: 2nd Side	* ENG	

2574	[Thick2:Switch Timing T-Edge]		
	Adjusts the bias/voltage switch timing of the paper transfer roller/discharge plate at the paper trailing edge between the erase margin area and the image area.		
001	Paper Transfer: 1st Side	* ENG	[0 to 50 / 0 / 2 mm/step]
002	Paper Transfer: 2nd Side	* ENG	
003	Separation DC: 1st Side	* ENG	
004	Separation DC: 2nd Side	* ENG	

2580	[Thick 2 Env. Correct Table]		
------	-------------------------------------	--	--

015	Separation DC: 1st Side	*ENG	[1 to 100 / 30 / 1 /step]
016	Separation DC: 2nd Side	*ENG	
[Thick 2 Edge-Env. Correct]			
019	Separation DC: 1st Side	*ENG	[1 to 100 / 30 / 1 /step]
020	Separation DC: 2nd Side	*ENG	
2601	[OHP: Bias]		
	Adjusts the DC voltage of the discharge plate for OHP.		
001	Separation DC	*ENG	[0 to 6000 / 2000 / 10 -V /step]
2603	[OHP: Bias: BW]		
	Adjusts the current for the paper transfer roller for OHP in black-and-white mode.		
001	Paper Transfer	*ENG	[0 to 230 / 8 / 1 - μ A /step]
2608	[OHP: Bias: FC]		
	Adjusts the current for the paper transfer roller for OHP in full color mode.		
001	Paper Transfer	*ENG	[0 to 230 / 21 / 1 - μ A /step]
2611	[OHP: Size Correction: BW]		
	Adjusts the size correction coefficient for the paper transfer roller current for each paper size. SP2603 and SP2608 are multiplied by these SP values.		
003	Paper Transfer: S1	*ENG	[100 to 995 / 100 / 5% /step] S1 size \geq 194 mm (Paper width)
007	Paper Transfer: S2	*ENG	[100 to 995 / 150 / 5% /step] 194 mm > S2 size \geq 165 mm (Paper width)
011	Paper Transfer: S3	*ENG	[100 to 995 / 150 / 5% /step] 165 mm > S3 size \geq 139 mm (Paper width)

015	Paper Transfer: S4	*ENG	[100 to 995 / 200 / 5% /step] 139 mm > S4 (Paper width)
-----	--------------------	------	---

2612	[OHP: Size Correction: FC]		
	Adjusts the size correction coefficient for the paper transfer roller current for each paper size. SP2603 and SP2608 are multiplied by these SP values.		
003	Paper Transfer: S1	*ENG	[100 to 995 / 100 / 5% /step] S1 size ≥ 194 mm (Paper width)
007	Paper Transfer: S2	*ENG	[100 to 995 / 150 / 5% /step] 194 mm > S2 size ≥ 165 mm (Paper width)
011	Paper Transfer: S3	*ENG	[100 to 995 / 150 / 5% /step] 165 mm > S3 size ≥ 139 mm (Paper width)
015	Paper Transfer: S4	*ENG	[100 to 995 / 200 / 5% /step] 139 mm > S4 (Paper width)

2613	[OHP: Size-Env. Correct: BW]		
	Adjusts the size correction coefficient for the paper transfer roller current for each paper size. SP2603 and SP2608 are multiplied by these SP values.		
003	Paper Transfer: S1	*ENG	[1 to 100 / 15 / 1 /step] S1 size ≥ 194 mm (Paper width)
007	Paper Transfer: S2	*ENG	[100 to 995 / 15 / 5% /step] 194 mm > S2 size ≥ 165 mm (Paper width)
011	Paper Transfer: S3	*ENG	[100 to 995 / 15 / 5% /step] 165 mm > S3 size ≥ 139 mm (Paper width)
015	Paper Transfer: S4	*ENG	[100 to 995 / 15 / 5% /step] 139 mm > S4 (Paper width)

2614	[OHP: Size-Env. Correct: FC]		
	Adjusts the size correction coefficient for the paper transfer roller current for each paper size. SP2603 and SP2608 are multiplied by these SP values.		
003	Paper Transfer: S1	*ENG	[1 to 100 / 12 / 1 /step] S1 size \geq 194 mm (Paper width)
007	Paper Transfer: S2	*ENG	[1 to 100 / 12 / 1 /step] 194 mm > S2 size \geq 165 mm (Paper width)
011	Paper Transfer: S3	*ENG	[1 to 100 / 12 / 1 /step] 165 mm > S3 size \geq 139 mm (Paper width)
015	Paper Transfer: S4	*ENG	[1 to 100 / 12 / 1 /step] 139 mm > S4 (Paper width)

5

2621	[OHP: Leading Edge Correction]		
	OHP: Leading Edge Correction		
Adjusts the correction to the paper transfer roller current at the paper leading edge in each mode. SP2603 and SP2608 are multiplied by these SP values.			
<div style="border: 1px solid blue; border-radius: 10px; padding: 2px; display: inline-block;">  Note </div> <ul style="list-style-type: none"> The paper leading edge area can be adjusted with SP2622. 			
001	Paper Transfer	*ENG	[0 to 995 / 100 / 5%/step]
002	Separation DC	*ENG	

2622	[OHP: Switch Timing: Lead. Edge]		
	Adjusts the bias/ voltage switch timing of the paper transfer roller/ discharge plate at the paper leading edge between the erase margin area and the image area.		
001	Paper Transfer	*ENG	[0 to 50 / 0 / 2 mm/step]
002	Separation DC	*ENG	

2623	[OHP: Trailing Edge Correction] OHP: Trailing Edge Correction		
	Adjusts the correction to the paper transfer roller current for the paper trailing edge in each mode. SP2603 and SP2608 are multiplied by these SP values.		
<div style="border: 1px solid blue; border-radius: 10px; padding: 2px; display: inline-block;"> ↓ Note </div> <ul style="list-style-type: none"> The paper trailing edge area can be adjusted with SP2624. 			
001	Paper Transfer	*ENG	[0 to 995 / 100 / 5%/step]
002	Separation DC	*ENG	

2624	[OHP: Switch Timing Trail. Edge]		
	Adjusts the bias/voltage switch timing of the paper transfer roller/discharge plate at the paper trailing edge between the erase margin area and the image area.		
001	Paper Transfer	*ENG	[0 to 50 / 0 / 2 mm/step]
002	Separation DC	*ENG	

2630	[OHP: Env. Correction Table]		
015	Separation DC	*ENG	[1 to 100 / 30 / 1 /step]
[OHP: Edge-Env. Correct]			
019	Separation DC	*ENG	[1 to 100 / 30 / 1 /step]

2647	[Thick3: Bias]		
	Adjusts the DC voltage of the discharge plate for thick paper 3.		
001	Separation DC: 1st Side	*ENG	[0 to 6000 / 2000 / 10 -V /step]
002	Separation DC: 2nd Side	*ENG	

2648	[Thick3: Bias: BW]		
	Adjusts the current for the paper transfer roller for thick paper 3 in black-and-white mode.		
001	Paper Transfer: 1st Side	*ENG	[0 to 230 / 9 / 1 - μ A /step]
002	Paper Transfer: 2nd Side	*ENG	[0 to 230 / 12 / 1 - μ A /step]

2649	[Thick3: Bias: FC]		
	Adjusts the current for the paper transfer roller for thick paper 3 in full color mode.		
001	Paper Transfer: 1st Side	*ENG	[0 to 230 / 12 / 1 – μ A /step]
002	Paper Transfer: 2nd Side	*ENG	[0 to 230 / 18 / 1 – μ A /step]

2650	[Thick3: Size Correction: BW]		
	Adjusts the size correction coefficient for the paper transfer roller current for each paper size. SP2648 and SP2649 are multiplied by these SP values.		
001	Paper Transfer: 1 Side: S1	*ENG	[100 to 995 / 100 / 5%/step]
002	Paper Transfer: 2 Side: S1	*ENG	S1 size \geq 194 mm (Paper width)
003	Paper Transfer: 1 Side: S2	*ENG	[100 to 995 / 150 / 5%/step] 194 mm > S2 size \geq 165 mm (Paper width)
004	Paper Transfer: 2 Side: S2	*ENG	[100 to 995 / 160 / 5%/step] 194 mm > S2 size \geq 165 mm (Paper width)
005	Paper Transfer: 1 Side: S3	*ENG	[100 to 995 / 150 / 5%/step] 165 mm > S3 size \geq 139 mm (Paper width)
006	Paper Transfer: 2 Side: S3	*ENG	[100 to 995 / 270 / 5%/step] 165 mm > S3 size \geq 139 mm (Paper width)
007	Paper Transfer: 1 Side: S4	*ENG	[100 to 995 / 200 / 5%/step] 139 mm > S4 (Paper width)
008	Paper Transfer: 2 Side: S4	*ENG	[100 to 995 / 435 / 5%/step] 139 mm > S4 (Paper width)

System SP2-xxx: 4

SP2-XXX (Drum)

2651	[Thick 3: Size Correction: FC]		
	Adjusts the size correction coefficient for the paper transfer roller current for each paper size. SP2648 and SP2649 are multiplied by these SP values.		
001	Paper Transfer: 1 Side: S1	*ENG	[100 to 995 / 100 / 5%/step]
002	Paper Transfer: 2 Side: S1	*ENG	S1 size \geq 194 mm (Paper width)
003	Paper Transfer: 1 Side: S2	*ENG	[100 to 995 / 150 / 5%/step] 194 mm > S2 size \geq 165 mm (Paper width)
004	Paper Transfer: 2 Side: S2	*ENG	[100 to 995 / 160 / 5%/step] 194 mm > S2 size \geq 165 mm (Paper width)
005	Paper Transfer: 1 Side: S3	*ENG	[100 to 995 / 150 / 5%/step] 165 mm > S3 size \geq 139 mm (Paper width)
006	Paper Transfer: 2 Side: S3	*ENG	[100 to 995 / 270 / 5%/step] 165 mm > S3 size \geq 139 mm (Paper width)
007	Paper Transfer: 1 Side: S4	*ENG	[100 to 995 / 200 / 5%/step] 139 mm > S4 (Paper width)
008	Paper Transfer: 2 Side: S4	*ENG	[100 to 995 / 435 / 5%/step] 139 mm > S4 (Paper width)

2652	[Thick 3: Size Env. Correct: BW]		
	Adjusts the size correction coefficient table for the paper transfer roller current for each paper size. SP2648 and SP2649 are multiplied by these SP values.		
001	Paper Transfer: 1 Side: S1	*ENG	[1 to 100 / 24 / 1 /step] S1 size \geq 194 mm (Paper width)

002	Paper Transfer: 2 Side: S1	*ENG	[1 to 100 / 22 / 1 /step] S1 size \geq 194 mm (Paper width)
003	Paper Transfer: 1 Side: S2	*ENG	[1 to 100 / 24 / 1 /step] 194 mm > S2 size \geq 165 mm (Paper width)
004	Paper Transfer: 2 Side: S2	*ENG	[1 to 100 / 22 / 1 /step] 194 mm > S2 size \geq 165 mm (Paper width)
005	Paper Transfer: 1 Side: S3	*ENG	[1 to 100 / 24 / 1 /step] 165 mm > S3 size \geq 139 mm (Paper width)
006	Paper Transfer: 2 Side: S3	*ENG	[1 to 100 / 22 / 1 /step] 165 mm > S3 size \geq 139 mm (Paper width)
007	Paper Transfer: 1 Side: S4	*ENG	[1 to 100 / 24 / 1 /step] 139 mm > S4 (Paper width)
008	Paper Transfer: 2 Side: S4	*ENG	[1 to 100 / 22 / 1 /step] 139 mm > S4 (Paper width)

2653	[Thick 3: Size Env. Correct: FC]		
	Adjusts the size correction coefficient table for the paper transfer roller current for each paper size. SP2648 and SP2649 are multiplied by these SP values.		
001	Paper Transfer: 1 Side: S1	*ENG	[1 to 100 / 24 / 1 /step] S1 size \geq 194 mm (Paper width)
002	Paper Transfer: 2 Side: S1	*ENG	[1 to 100 / 27 / 1 /step] S1 size \geq 194 mm (Paper width)
003	Paper Transfer: 1 Side: S2	*ENG	[1 to 100 / 24 / 1 /step] 194 mm > S2 size \geq 165 mm (Paper width)
004	Paper Transfer: 2 Side: S2	*ENG	[1 to 100 / 27 / 1 /step] 194 mm > S2 size \geq 165 mm (Paper width)

005	Paper Transfer: 1 Side: S3	*ENG	[1 to 100 / 24 / 1 /step] 165 mm > S3 size ≥ 139 mm (Paper width)
006	Paper Transfer: 2 Side: S3	*ENG	[1 to 100 / 27 / 1 /step] 165 mm > S3 size ≥ 139 mm (Paper width)
007	Paper Transfer: 1 Side: S4	*ENG	[1 to 100 / 24 / 1 /step] 139 mm > S4 (Paper width)
008	Paper Transfer: 2 Side: S4	*ENG	[1 to 100 / 27 / 1 /step] 139 mm > S4 (Paper width)

5

2654	[Thick 3: L-Edge Correction]		
	Thick 3 Paper: Leading Edge Correction		
	Adjusts the correction to the paper transfer roller current at the paper leading edge in each mode. SP2648 and SP2649 are multiplied by these SP values.		
	<p>Note</p> <ul style="list-style-type: none"> The paper leading edge area can be adjusted with SP2655. 		
	001	Paper Transfer: 1st Side	*ENG
002	Paper Transfer: 2nd Side	*ENG	[0 to 995 / 100 / 5%/step]
003	Separation DC: 1st Side	*ENG	
004	Separation DC: 2nd Side	*ENG	

2655	[Thick 3: Switch Timing: L-Edge]			
	Adjusts the bias/ voltage switch timing of the paper transfer roller/ discharge plate at the paper leading edge between the erase margin area and the image area.			
	001	Paper Transfer: 1st Side	*ENG	
	002	Paper Transfer: 2nd Side	*ENG	[0 to 50 / 0 / 2 mm/step]
	003	Separation DC: 1st Side	*ENG	
004	Separation DC: 2nd Side	*ENG		

2656	[Thick 3: T-Edge Correction] Thick 3 Paper: Trailing Edge Correction		
	Adjusts the correction to the paper transfer roller current for the paper trailing edge in each mode. SP2648 and SP2649 are multiplied by these SP values. Note <ul style="list-style-type: none"> The paper trailing edge area can be adjusted with SP2657. 		
001	Paper Transfer: 1st Side	* ENG	[0 to 995 / 100 / 5%/step]
002	Paper Transfer: 2nd Side	* ENG	
003	Separation DC: 1st Side	* ENG	
004	Separation DC: 2nd Side	* ENG	
2657	[Thick 3: Switch Timing: T-Edge]		
	Adjusts the bias/voltage switch timing of the paper transfer roller/discharge plate at the paper trailing edge between the erase margin area and the image area.		
001	Paper Transfer: 1st Side	* ENG	[0 to 50 / 0 / 2 mm/step]
002	Paper Transfer: 2nd Side	* ENG	
003	Separation DC: 1st Side	* ENG	
004	Separation DC: 2nd Side	* ENG	
2660	[Thick 3: Env. Correction Table] Thick 3 Paper: MM Environment Coefficient Adjustment		
	015	Separation DC: 1st Side	* ENG
016	Separation DC: 2nd Side	* ENG	
[Thick 3: Edge-Env. Correct]			
019	Separation DC: 1st Side	* ENG	[1 to 100 / 30 / 1 /step]
020	Separation DC: 2nd Side	* ENG	
2701	[MiddleThick Bias]		
	Adjusts the DC voltage of the discharge plate for middle thick paper.		

001	Separation DC: Standard Spd: 1st Side	*ENG	[0 to 6000 / 2000 / 10 -V / step]
002	Separation DC: Standard Spd: 2nd Side	*ENG	
003	Separation DC: Low Spd: 1st Side	*ENG	
004	Separation DC: Low Spd: 2nd Side	*ENG	

2703	[Middle Thick:Bias:BW]		
	Standard: 260mm/sec, Low: 85mm/sec Adjusts the current for the paper transfer roller for middle thick in black-and-white mode.		
001	Paper Transfer:Standard:1st Side	*ENG	[0 to 230 / 20 / 1-μA /step]
002	Paper Transfer: Standard:2nd Side	*ENG	[0 to 230 / 18 / 1-μA /step]
003	Paper Transfer: Low: 1st Side	*ENG	[0 to 230 / 10 / 1-μA /step]
004	Paper Transfer: Low: 2nd Side	*ENG	[0 to 230 / 12 / 1-μA /step]

2707	[Middle Thick:Bias:FC]		
	Standard: 260mm/sec, Low: 85mm/sec Adjusts the current for the paper transfer roller for middle thick in full color mode.		
001	Paper Transfer: Standard:1st Side	*ENG	[0 to 230 / 35 / 1-μA /step]
002	Paper Transfer: Standard:2nd Side	*ENG	[0 to 230 / 25 / 1-μA /step]
003	Paper Transfer: Low: 1st Side	*ENG	[0 to 230 / 12 / 1-μA /step]
004	Paper Transfer: Low: 2nd Side	*ENG	[0 to 230 / 14 / 1-μA /step]

2713	[M-Thick: Size Correct: BW]		
	Adjusts the size correction coefficient for the paper transfer roller current for each paper size. SP2703 and SP2707 are multiplied by these SP values. Standard: 260mm/sec, Low: 85mm/sec		

001	Paper Transfer: Standard: 1Side: S1	*ENG	[100 to 995 / 100 / 5%/step] S1 size \geq 194 mm (Paper width)
002	Paper Transfer: Standard: 2Side: S1	*ENG	
003	Paper Transfer: Low: 1 Side: S1	*ENG	
004	Paper Transfer: Low: 2 Side: S1	*ENG	
005	Paper Transfer: Standard: 1Side: S2	*ENG	[100 to 995 / 135 / 5%/step] 194 mm > S2 size \geq 165 mm (Paper width)
006	Paper Transfer: Standard: 2Side: S2	*ENG	[100 to 995 / 200 / 5%/step] 194 mm > S2 size \geq 165 mm (Paper width)
007	Paper Transfer: Low: 1 Side: S2	*ENG	[100 to 995 / 135 / 5%/step] 194 mm > S2 size \geq 165 mm (Paper width)
008	Paper Transfer: Low: 2 Side: S2	*ENG	[100 to 995 / 200 / 5%/step] 194 mm > S2 size \geq 165 mm (Paper width)
009	Paper Transfer: Standard: 1Side: S3	*ENG	[100 to 995 / 135 / 5%/step] 165 mm > S3 size \geq 139 mm (Paper width)
010	Paper Transfer: Standard: 2Side: S3	*ENG	[100 to 995 / 390 / 5%/step] 165 mm > S3 size \geq 139 mm (Paper width)
011	Paper Transfer: Low: 1 Side: S3	*ENG	[100 to 995 / 135 / 5%/step] 165 mm > S3 size \geq 139 mm (Paper width)
012	Paper Transfer: Low: 2 Side: S3	*ENG	[100 to 995 / 390 / 5%/step] 165 mm > S3 size \geq 139 mm (Paper width)
013	Paper Transfer: Standard: 1Side: S4	*ENG	[100 to 995 / 220 / 5%/step] 139 mm > S4 (Paper width)

014	Paper Transfer: Standard: 2Side: S4	*ENG	[100 to 995 / 330 / 5%/step] 139 mm > S4 (Paper width)
015	Paper Transfer: Low: 1 Side: S4	*ENG	[100 to 995 / 220 / 5%/step] 139 mm > S4 (Paper width)
016	Paper Transfer: Low: 2 Side: S4	*ENG	[100 to 995 / 330 / 5%/step] 139 mm > S4 (Paper width)

2714	[M-Thick: Size Correct: FC]			
	Adjusts the size correction coefficient for the paper transfer roller current for each paper size. SP2703 and SP2707 are multiplied by these SP values. Standard: 260mm/sec, Low: 85mm/sec			
	001	Paper Transfer: Standard: 1Side: S1	*ENG	
	002	Paper Transfer: Standard: 2Side: S1	*ENG	[100 to 995 / 100 / 5%/step] S1 size ≥ 194 mm (Paper width)
	003	Paper Transfer: Low: 1 Side: S1	*ENG	
004	Paper Transfer: Low: 2 Side: S1	*ENG		
005	Paper Transfer: Standard: 1Side: S2	*ENG	[100 to 995 / 135 / 5%/step] 194 mm > S2 size ≥ 165 mm (Paper width)	
006	Paper Transfer: Standard: 2Side: S2	*ENG	[100 to 995 / 200 / 5%/step] 194 mm > S2 size ≥ 165 mm (Paper width)	
007	Paper Transfer: Low: 1 Side: S2	*ENG	[100 to 995 / 135 / 5%/step] 194 mm > S2 size ≥ 165 mm (Paper width)	
008	Paper Transfer: Low: 2 Side: S2	*ENG	[100 to 995 / 200 / 5%/step] 194 mm > S2 size ≥ 165 mm (Paper width)	
009	Paper Transfer: Standard: 1Side: S3	*ENG	[100 to 995 / 135 / 5%/step] 165 mm > S3 size ≥ 139 mm (Paper width)	

010	Paper Transfer: Standard: 2Side: S3	*ENG	[100 to 995 / 325 / 5%/step] 165 mm > S3 size ≥ 139 mm (Paper width)
011	Paper Transfer: Low: 1 Side: S3	*ENG	[100 to 995 / 135 / 5%/step] 165 mm > S3 size ≥ 139 mm (Paper width)
012	Paper Transfer: Low: 2 Side: S3	*ENG	[100 to 995 / 325 / 5%/step] 165 mm > S3 size ≥ 139 mm (Paper width)
013	Paper Transfer: Standard: 1Side: S4	*ENG	[100 to 995 / 220 / 5%/step] 139 mm > S4 (Paper width)
014	Paper Transfer: Standard: 2Side: S4	*ENG	[100 to 995 / 330 / 5%/step] 139 mm > S4 (Paper width)
015	Paper Transfer: Low: 1 Side: S4	*ENG	[100 to 995 / 220 / 5%/step] 139 mm > S4 (Paper width)
016	Paper Transfer: Low: 2 Side: S4	*ENG	[100 to 995 / 330 / 5%/step] 139 mm > S4 (Paper width)

2715	[M-Thick: Size Env. Correct: BW]		
	Adjusts the size correction coefficient for the paper transfer roller current for each paper size. SP2703 and SP2707 are multiplied by these SP values. Standard: 260mm/sec, Low: 85mm/sec		
001	Paper Transfer: Standard: 1Side: S1	*ENG	[1 to 100 / 14 / 1 /step] S1 size ≥ 194 mm (Paper width)
002	Paper Transfer: Standard: 2Side: S1	*ENG	[1 to 100 / 13 / 1 /step] S1 size ≥ 194 mm (Paper width)
003	Paper Transfer: Low: 1 Side: S1	*ENG	[1 to 100 / 10 / 1 /step] S1 size ≥ 194 mm (Paper width)
004	Paper Transfer: Low: 2 Side: S1	*ENG	[1 to 100 / 12 / 1 /step] S1 size ≥ 194 mm (Paper width)

005	Paper Transfer: Standard: 1Side: S2	*ENG	[1 to 100 / 14 / 1 /step] 194 mm > S2 size ≥ 165 mm (Paper width)
006	Paper Transfer: Standard: 2Side: S2	*ENG	[1 to 100 / 13 / 1 /step] 194 mm > S2 size ≥ 165 mm (Paper width)
007	Paper Transfer: Low: 1 Side: S2	*ENG	[1 to 100 / 10 / 1 /step] 194 mm > S2 size ≥ 165 mm (Paper width)
008	Paper Transfer: Low: 2 Side: S2	*ENG	[1 to 100 / 12 / 1 /step] 194 mm > S2 size ≥ 165 mm (Paper width)
009	Paper Transfer: Standard: 1Side: S3	*ENG	[1 to 100 / 14 / 1 /step] 165 mm > S3 size ≥ 139 mm (Paper width)
010	Paper Transfer: Standard: 2Side: S3	*ENG	[1 to 100 / 5 / 1 /step] 165 mm > S3 size ≥ 139 mm (Paper width)
011	Paper Transfer: Low: 1 Side: S3	*ENG	[1 to 100 / 10 / 1 /step] 165 mm > S3 size ≥ 139 mm (Paper width)
012	Paper Transfer: Low: 2 Side: S3	*ENG	[1 to 100 / 5 / 1 /step] 165 mm > S3 size ≥ 139 mm (Paper width)
013	Paper Transfer: Standard: 1Side: S4	*ENG	[1 to 100 / 14 / 1 /step] 139 mm > S4 (Paper width)
014	Paper Transfer: Standard: 2Side: S4	*ENG	[1 to 100 / 13 / 1 /step] 139 mm > S4 (Paper width)
015	Paper Transfer: Low: 1 Side: S4	*ENG	[1 to 100 / 10 / 1 /step] 139 mm > S4 (Paper width)

016	Paper Transfer: Low: 2 Side: S4	*ENG	[1 to 100 / 12 / 1 /step] 139 mm > S4 (Paper width)
-----	---------------------------------	------	---

2716	[M-Thick: Size Env. Correct: FC]		
	Adjusts the size correction coefficient for the paper transfer roller current for each paper size. SP2703 and SP2707 are multiplied by these SP values. Standard: 260mm/sec, Low: 85mm/sec		
001	Paper Transfer: Standard: 1Side: S1	*ENG	[1 to 100 / 7 / 1 /step] S1 size ≥ 194 mm (Paper width)
002	Paper Transfer: Standard: 2Side: S1	*ENG	[1 to 100 / 43 / 1 /step] S1 size ≥ 194 mm (Paper width)
003	Paper Transfer: Low: 1 Side: S1	*ENG	[1 to 100 / 37 / 1 /step] S1 size ≥ 194 mm (Paper width)
004	Paper Transfer: Low: 2 Side: S1	*ENG	[1 to 100 / 41 / 1 /step] S1 size ≥ 194 mm (Paper width)
005	Paper Transfer: Standard: 1Side: S2	*ENG	[1 to 100 / 1 / 1 /step] 194 mm > S2 size ≥ 165 mm (Paper width)
006	Paper Transfer: Standard: 2Side: S2	*ENG	[1 to 100 / 42 / 1 /step] 194 mm > S2 size ≥ 165 mm (Paper width)
007	Paper Transfer: Low: 1 Side: S2	*ENG	[1 to 100 / 10 / 1 /step] 194 mm > S2 size ≥ 165 mm (Paper width)
008	Paper Transfer: Low: 2 Side: S2	*ENG	[1 to 100 / 12 / 1 /step] 194 mm > S2 size ≥ 165 mm (Paper width)
009	Paper Transfer: Standard: 1Side: S3	*ENG	[1 to 100 / 1 / 1 /step] 165 mm > S3 size ≥ 139 mm (Paper width)

010	Paper Transfer: Standard: 2Side: S3	*ENG	[1 to 100 / 23 / 1 /step] 165 mm > S3 size ≥ 139 mm (Paper width)
011	Paper Transfer: Low: 1 Side: S3	*ENG	[1 to 100 / 37 / 1 /step] 165 mm > S3 size ≥ 139 mm (Paper width)
012	Paper Transfer: Low: 2 Side: S3	*ENG	[1 to 100 / 39 / 1 /step] 165 mm > S3 size ≥ 139 mm (Paper width)
013	Paper Transfer: Standard: 1Side: S4	*ENG	[1 to 100 / 7 / 1 /step] 139 mm > S4 (Paper width)
014	Paper Transfer: Standard: 2Side: S4	*ENG	[1 to 100 / 43 / 1 /step] 139 mm > S4 (Paper width)
015	Paper Transfer: Low: 1 Side: S4	*ENG	[1 to 100 / 37 / 1 /step] 139 mm > S4 (Paper width)
016	Paper Transfer: Low: 2 Side: S4	*ENG	[1 to 100 / 41 / 1 /step] 139 mm > S4 (Paper width)

2721	[M-Thick:L-Edge Correct] Standard: 260 mm/sec, Low: 85 mm/sec
	Adjusts the correction to the paper transfer roller current at the paper leading edge in each mode. SP2703 and SP2707 are multiplied by these SP values. Note <ul style="list-style-type: none"> The paper leading edge area can be adjusted with SP2722.

001	Paper Transfer: Standard: 1st Side	*ENG	[0 to 995 / 100 / 5% /step]
002	Paper Transfer: Standard:2nd Side	*ENG	
003	Paper Transfer: Low: 1st Side	*ENG	
004	Paper Transfer: Low: 2nd Side	*ENG	
005	Separation DC: Standard: 1st Side	*ENG	
006	Separation DC: Standard: 2nd Side	*ENG	
007	Separation DC: Low: 1st Side	*ENG	
008	Separation DC: Low: 2nd Side	*ENG	

2722	[M-Thick:Switch Timing:L-Edge]		
	Standard: 260 mm/sec, Low: 85 mm/sec		
Adjusts the bias/ voltage switch timing of the paper transfer roller/ discharge plate at the paper leading edge between the erase margin area and the image area.			
001	Paper Transfer: Standard: 1st	*ENG	[0 to 50 / 0 / 2mm /step]
002	Paper Transfer: Standard:2nd	*ENG	
003	Paper Transfer: Low: 1st	*ENG	
004	Paper Transfer: Low: 2nd	*ENG	
005	Separation DC: Standard: 1st	*ENG	
006	Separation DC: Standard: 2nd	*ENG	
007	Separation DC: Low: 1st	*ENG	
008	Separation DC: Low: 2nd	*ENG	

2723	[M-Thick:T-Edge Correction]		
	Standard: 260 mm/sec, Low: 85 mm/sec		
Adjusts the correction to the paper transfer roller current for the paper trailing edge in each mode. SP2703 and SP2707 are multiplied by these SP values.			
<div style="border: 1px solid blue; border-radius: 10px; padding: 2px; display: inline-block;">  Note </div> <ul style="list-style-type: none"> The paper trailing edge area can be adjusted with SP2724 			

001	Paper Transfer: Standard: 1st Side	*ENG	[0 to 995 / 100 / 5% /step]
002	Paper Transfer: Standard:2nd Side	*ENG	
003	Paper Transfer: Low: 1st Side	*ENG	
004	Paper Transfer: Low: 2nd Side	*ENG	
005	Separation DC: Standard: 1st Side	*ENG	
006	Separation DC: Standard: 2nd Side	*ENG	
007	Separation DC: Low: 1st Side	*ENG	
008	Separation DC: Low: 2nd Side	*ENG	

5

2724	[M-Thick:Switch Timing:T-Edge] Standard: 260 mm/sec, Low: 85 mm/sec		
	Adjusts the bias/voltage switch timing of the paper transfer roller/discharge plate at the paper trailing edge between the erase margin area and the image area.		
001	Paper Transfer: Standard: 1st Side	*ENG	[0 to 50 / 0 / 2mm /step]
002	Paper Transfer: Standard:2nd Side	*ENG	
003	Paper Transfer: Low: 1st Side	*ENG	
004	Paper Transfer: Low: 2nd Side	*ENG	
005	Separation DC: Standard: 1st Side	*ENG	
006	Separation DC: Standard: 2nd Side	*ENG	
007	Separation DC: Low: 1st Side	*ENG	
008	Separation DC: Low: 2nd Side	*ENG	

2730	[M-Thick:Env.Correct Table] Standard: 260 mm/sec, Low: 85 mm/sec		
------	--	--	--

013	Separation DC: Standard: 1st Side	*ENG	[1 to 100 / 30 / 1 /step]
014	Separation DC: Standard: 2nd Side	*ENG	
015	Separation DC: Low: 1st Side	*ENG	
016	Separation DC: Low: 2nd Side	*ENG	

[M-Thick:Edge-Env.Correct]

017	Separation DC: Standard: 1st Side	*ENG	[1 to 100 / 50 / 1 /step]
018	Separation DC: Standard: 2nd Side	*ENG	
019	Separation DC: Low: 1st Side	*ENG	
020	Separation DC: Low: 2nd Side	*ENG	

2751	[Special 1: Bias]		
	Adjusts the DC voltage of the discharge plate for special paper 1. Standard: 260 mm/sec, Low: 85 mm/sec		
001	Separation DC: Standard Spd: 1st Side	*ENG	[0 to 6000 / 2000 / 10 -V / step]
002	Separation DC: Standard Spd: 2nd Side	*ENG	
003	Separation DC: Low Spd: 1st Side	*ENG	
004	Separation DC: Low Spd: 2nd Side	*ENG	

2753	[Special 1: Bias: BW]		
	Adjusts the current for the paper transfer roller for special paper 1 in black-and-white mode. Standard: 260 mm/sec, Low: 85 mm/sec		
001	Paper Transfer: Standard: 1st Side	*ENG	[0 to 230 / 20 / 1 - μ A /step]
002	Paper Transfer: Standard: 2nd Side	*ENG	[0 to 230 / 18 / 1 - μ A /step]
003	Paper Transfer: Low: 1st Side	*ENG	[0 to 230 / 10 / 1 - μ A /step]
004	Paper Transfer: Low: 2nd Side	*ENG	[0 to 230 / 12 / 1 - μ A /step]

2757	[Special 1: Bias: FC]		
	Adjusts the current for the paper transfer roller for special paper 1 in full color mode. Standard: 260 mm/sec, Low: 85 mm/sec		
001	Paper Transfer: Standard: 1st Side	*ENG	[0 to 230 / 35 / 1 –µA /step]
002	Paper Transfer: Standard: 2nd Side	*ENG	[0 to 230 / 25 / 1 –µA /step]
003	Paper Transfer: Low: 1st Side	*ENG	[0 to 230 / 12 / 1 –µA /step]
004	Paper Transfer: Low: 2nd Side	*ENG	[0 to 230 / 14 / 1 –µA /step]

2761	[Special 1:Size Correct:BW]		
	Adjusts the size correction coefficient for the paper transfer roller current for each paper size. SP2753 and SP2757 are multiplied by these SP values. Standard: 260 mm/sec, Low: 85 mm/sec		
001	Paper Transfer: Standard: 1st Side: S1	*ENG	[100 to 995 / 100 / 5%/step] S1 size ≥ 194 mm (Paper width)
002	Paper Transfer: Standard: 2nd Side: S1	*ENG	
003	Paper Transfer:Low: 1st Side:S1	*ENG	
004	Paper Transfer:Low:2nd Side:S1	*ENG	
005	Paper Transfer: Standard: 1st Side: S2	*ENG	[100 to 995 / 135 / 5%/step] 194 mm > S2 size ≥ 165 mm (Paper width)
006	Paper Transfer: Standard: 2nd Side: S2	*ENG	[100 to 995 / 200 / 5%/step] 194 mm > S2 size ≥ 165 mm (Paper width)
007	Paper Transfer:Low: 1st Side:S2	*ENG	[100 to 995 / 135 / 5%/step] 194 mm > S2 size ≥ 165 mm (Paper width)

008	Paper Transfer:Low:2nd Side:S2	*ENG	[100 to 995 / 200 / 5%/step] 194 mm > S2 size ≥ 165 mm (Paper width)
009	Paper Transfer: Standard: 1st: S3	*ENG	[100 to 995 / 135 / 5%/step] 165 mm > S3 size ≥ 139 mm (Paper width)
010	Paper Transfer: Standard: 2nd Side: S3	*ENG	[100 to 995 / 390 / 5%/step] 165 mm > S3 size ≥ 139 mm (Paper width)
011	PaperTransfer:Low:1st Side:S3	*ENG	[100 to 995 / 135 / 5%/step] 165 mm > S3 size ≥ 139 mm (Paper width)
012	PaperTransfer:Low:2nd Side:S3	*ENG	[100 to 995 / 390 / 5%/step] 165 mm > S3 size ≥ 139 mm (Paper width)
013	Paper Transfer: Standard: 1st Side: S4	*ENG	[100 to 995 / 220 / 5%/step] 139 mm > S4 (Paper width)
014	Paper Transfer: Standard: 2nd Side: S4	*ENG	[100 to 995 / 330 / 5%/step] 139 mm > S4 (Paper width)
015	PaperTransfer:Low:1st Side:S4	*ENG	[100 to 995 / 220 / 5%/step] 139 mm > S4 (Paper width)
016	PaperTransfer:Low:2nd Side:S4	*ENG	[100 to 995 / 330 / 5%/step] 139 mm > S4 (Paper width)

2762	[Special 1:Size Correct:FC]
	Adjusts the size correction coefficient for the paper transfer roller current for each paper size. SP2753 and SP2757 are multiplied by these SP values. Standard: 260 mm/sec, Low: 85 mm/sec

001	Paper Transfer: Standard: 1st Side: S1	*ENG	
002	Paper Transfer: Standard: 2nd Side: S1	*ENG	[100 to 995 / 100 / 5%/step] S1 size ≥ 194 mm (Paper width)
003	Paper Transfer:Low: 1st Side:S1	*ENG	
004	Paper Transfer:Low:2nd Side:S1	*ENG	
005	Paper Transfer: Standard: 1st Side: S2	*ENG	[100 to 995 / 135 / 5%/step] 194 mm > S2 size ≥ 165 mm (Paper width)
006	Paper Transfer: Standard: 2nd Side: S2	*ENG	[100 to 995 / 200 / 5%/step] 194 mm > S2 size ≥ 165 mm (Paper width)
007	Paper Transfer:Low: 1st Side:S2	*ENG	[100 to 995 / 135 / 5%/step] 194 mm > S2 size ≥ 165 mm (Paper width)
008	Paper Transfer:Low:2nd Side:S2	*ENG	[100 to 995 / 200 / 5%/step] 194 mm > S2 size ≥ 165 mm (Paper width)
009	Paper Transfer: Standard: 1st Side: S3	*ENG	[100 to 995 / 135 / 5%/step] 165 mm > S3 size ≥ 139 mm (Paper width)
010	Paper Transfer: Standard: 2nd Side: S3	*ENG	[100 to 995 / 325 / 5%/step] 165 mm > S3 size ≥ 139 mm (Paper width)
011	PaperTransfer:Low:1st Side:S3	*ENG	[100 to 995 / 135 / 5%/step] 165 mm > S3 size ≥ 139 mm (Paper width)
012	PaperTransfer:Low:2nd Side:S3	*ENG	[100 to 995 / 325 / 5%/step] 165 mm > S3 size ≥ 139 mm (Paper width)

013	Paper Transfer: Standard: 1st Side: S4	*ENG	[100 to 995 / 220 / 5%/step] 139 mm > S4 (Paper width)
014	Paper Transfer: Standard: 2nd Side: S4	*ENG	[100 to 995 / 330 / 5%/step] 139 mm > S4 (Paper width)
015	PaperTransfer:Low: 1st Side:S4	*ENG	[100 to 995 / 220 / 5%/step] 139 mm > S4 (Paper width)
016	PaperTransfer:Low:2nd Side:S4	*ENG	[100 to 995 / 330 / 5%/step] 139 mm > S4 (Paper width)

2763	[Special 1:Size Env.Correct:BW]		
	Adjusts the size correction coefficient table for the paper transfer roller current for each paper size. SP2753 and SP2757 are multiplied by these SP values. Standard: 260 mm/sec, Low: 85 mm/sec		
001	Paper Transfer: Standard: 1st Side: S1	*ENG	[1 to 100 / 14 / 1 /step] S1 size ≥ 194 mm (Paper width)
002	Paper Transfer: Standard: 2nd Side: S1	*ENG	[1 to 100 / 13 / 1 /step] S1 size ≥ 194 mm (Paper width)
003	Paper Transfer:Low: 1st Side:S1	*ENG	[1 to 100 / 10 / 1 /step] S1 size ≥ 194 mm (Paper width)
004	Paper Transfer:Low:2nd Side:S1	*ENG	[1 to 100 / 12 / 1 /step] S1 size ≥ 194 mm (Paper width)
005	Paper Transfer: Standard: 1st Side: S2	*ENG	[1 to 100 / 14 / 1 /step] 194 mm > S2 size ≥ 165 mm (Paper width)
006	Paper Transfer: Standard: 2nd Side: S2	*ENG	[1 to 100 / 13 / 1 /step] 194 mm > S2 size ≥ 165 mm (Paper width)
007	Paper Transfer:Low: 1st Side:S2	*ENG	[1 to 100 / 10 / 1 /step] 194 mm > S2 size ≥ 165 mm (Paper width)

008	Paper Transfer:Low:2nd Side:S2	*ENG	[1 to 100 / 12 / 1 /step] 194 mm > S2 size ≥ 165 mm (Paper width)
009	Paper Transfer: Standard: 1st Side: S3	*ENG	[1 to 100 / 14 / 1 /step] 165 mm > S3 size ≥ 139 mm (Paper width)
010	Paper Transfer: Standard: 2nd Side: S3	*ENG	[1 to 100 / 5 / 1 /step] 165 mm > S3 size ≥ 139 mm (Paper width)
011	PaperTransfer:Low:1st Side:S3	*ENG	[1 to 100 / 10 / 1 /step] 165 mm > S3 size ≥ 139 mm (Paper width)
012	PaperTransfer:Low:2nd Side:S3	*ENG	[1 to 100 / 5 / 1 /step] 165 mm > S3 size ≥ 139 mm (Paper width)
013	Paper Transfer: Standard: 1st Side: S4	*ENG	[1 to 100 / 14 / 1 /step] 139 mm > S4 (Paper width)
014	Paper Transfer: Standard: 2nd Side: S4	*ENG	[1 to 100 / 13 / 1 /step] 139 mm > S4 (Paper width)
015	PaperTransfer:Low:1st Side:S4	*ENG	[1 to 100 / 10 / 1 /step] 139 mm > S4 (Paper width)
016	PaperTransfer:Low:2nd Side:S4	*ENG	[1 to 100 / 12 / 1 /step] 139 mm > S4 (Paper width)

2764	[Special 1:Size Env.Correct:FC]		
	Adjusts the size correction coefficient table for the paper transfer roller current for each paper size. SP2753 and SP2757 are multiplied by these SP values. Standard: 260 mm/sec, Low: 85 mm/sec		
001	Paper Transfer: Standard: 1st Side: S1	*ENG	[1 to 100 / 7 / 1 /step] S1 size ≥ 194 mm (Paper width)

002	Paper Transfer: Standard: 2nd Side: S1	*ENG	[1 to 100 / 43 / 1 /step] S1 size \geq 194 mm (Paper width)
003	Paper Transfer:Low: 1st Side:S1	*ENG	[1 to 100 / 37 / 1 /step] S1 size \geq 194 mm (Paper width)
004	Paper Transfer:Low:2nd Side:S1	*ENG	[1 to 100 / 41 / 1 /step] S1 size \geq 194 mm (Paper width)
005	Paper Transfer: Standard: 1st Side: S2	*ENG	[1 to 100 / 1 / 1 /step] 194 mm > S2 size \geq 165 mm (Paper width)
006	Paper Transfer: Standard: 2nd Side: S2	*ENG	[1 to 100 / 42 / 1 /step] 194 mm > S2 size \geq 165 mm (Paper width)
007	Paper Transfer:Low: 1st Side:S2	*ENG	[1 to 100 / 37 / 1 /step] 194 mm > S2 size \geq 165 mm (Paper width)
008	Paper Transfer:Low:2nd Side:S2	*ENG	[1 to 100 / 40 / 1 /step] 194 mm > S2 size \geq 165 mm (Paper width)
009	Paper Transfer: Standard: 1st Side: S3	*ENG	[1 to 100 / 1 / 1 /step] 165 mm > S3 size \geq 139 mm (Paper width)
010	Paper Transfer: Standard: 2nd Side: S3	*ENG	[1 to 100 / 23 / 1 /step] 165 mm > S3 size \geq 139 mm (Paper width)
011	PaperTransfer:Low: 1st Side:S3	*ENG	[1 to 100 / 37 / 1 /step] 165 mm > S3 size \geq 139 mm (Paper width)
012	PaperTransfer:Low:2nd Side:S3	*ENG	[1 to 100 / 39 / 1 /step] 165 mm > S3 size \geq 139 mm (Paper width)

013	Paper Transfer: Standard: 1st Side: S4	*ENG	[1 to 100 / 7 / 1 /step] 139 mm > S4 (Paper width)
014	Paper Transfer: Standard: 2nd Side: S4	*ENG	[1 to 100 / 43 / 1 /step] 139 mm > S4 (Paper width)
015	PaperTransfer:Low:1st Side:S4	*ENG	[1 to 100 / 37 / 1 /step] 139 mm > S4 (Paper width)
016	PaperTransfer:Low:2nd Side:S4	*ENG	[1 to 100 / 41 / 1 /step] 139 mm > S4 (Paper width)

System SP2-xxx: 5

SP2-XXX (Drum)

2771	[Special 1: L-Edge Correction]		
	Special 1 Paper: Leading Edge Correction		
	Adjusts the correction to the paper transfer roller current at the paper leading edge in each mode. SP2753 and SP2757 are multiplied by these SP values.		
	Standard: 260 mm/sec, Low: 85 mm/sec		
	<div style="border: 1px solid black; border-radius: 10px; padding: 2px; display: inline-block;">  Note </div>		
	<ul style="list-style-type: none"> The paper leading edge area can be adjusted with SP2772. 		
001	Paper Transfer: Standard: 1st Side	* ENG	[0 to 995 / 100 / 5%/step]
002	Paper Transfer: Standard: 2nd Side	* ENG	
003	Paper Transfer: Low: 1st Side	* ENG	
004	Paper Transfer: Low: 2nd Side	* ENG	
005	Separation DC: Standard: 1st Side	* ENG	
006	Separation DC: Standard: 2nd Side	* ENG	
007	Separation DC: Low: 1st Side	* ENG	
008	Separation DC: Low: 2nd Side	* ENG	
2772	[Special 1: Switch Timing: L-Edge]		
	Adjusts the bias/ voltage switch timing of the paper transfer roller/ discharge plate at the paper leading edge between the erase margin area and the image area.		
	Standard: 260 mm/sec, Low: 85 mm/sec		

001	Paper Transfer: Standard: 1st Side	*ENG	[0 to 50 / 0 / 2 mm/step]
002	Paper Transfer: Standard: 2nd Side	*ENG	
003	Paper Transfer: Low: 1st Side	*ENG	
004	Paper Transfer: Low: 2nd Side	*ENG	
005	Separation DC: Standard: 1st Side	*ENG	
006	Separation DC: Standard: 2nd Side	*ENG	
007	Separation DC: Low: 1st Side	*ENG	
008	Separation DC: Low: 2nd Side	*ENG	

5

2773	[Special 1: T-Edge Correction]		[0 to 995 / 100 / 5%/step]	
	Special 1 Paper: Trailing Edge Correction			
	Adjusts the correction to the paper transfer roller current for the paper trailing edge in each mode. SP2753 and SP2757 are multiplied by these SP values. Standard: 260 mm/sec, Low: 85 mm/sec			
	 Note			
	<ul style="list-style-type: none"> The paper trailing edge area can be adjusted with SP2774. 			
	001	Paper Transfer: Standard: 1st Side		*ENG
	002	Paper Transfer: Standard: 2nd Side		*ENG
	003	Paper Transfer: Low: 1st Side		*ENG
	004	Paper Transfer: Low: 2nd Side		*ENG
005	Separation DC: Standard: 1st Side	*ENG		
006	Separation DC: Standard: 2nd Side	*ENG		
007	Separation DC: Low: 1st Side	*ENG		
008	Separation DC: Low: 2nd Side	*ENG		

2774	[Special 1: Switch Timing:T-Edge]		
	Adjusts the bias/voltage switch timing of the paper transfer roller/discharge plate at the paper trailing edge between the erase margin area and the image area. Standard: 260 mm/sec, Low: 85 mm/sec		
001	Paper Transfer: Standard: 1st Side	*ENG	[0 to 50 / 0 / 2 mm/step]
002	Paper Transfer: Standard: 2nd Side	*ENG	
003	Paper Transfer: Low: 1st Side	*ENG	
004	Paper Transfer: Low: 2nd Side	*ENG	
005	Separation DC: Standard: 1st Side	*ENG	
006	Separation DC: Standard: 2nd Side	*ENG	
007	Separation DC: Low: 1st Side	*ENG	
008	Separation DC: Low: 2nd Side	*ENG	

2780	[Special 1: Env. Correct Table]		
	Standard: 260 mm/sec, Low: 85 mm/sec		
013	Separation DC: Standard: 1st Side	*ENG	[1 to 100 / 30 / 1 /step]
014	Separation DC: Standard: 2nd Side	*ENG	
015	Separation DC: Low: 1st Side	*ENG	
016	Separation DC: Low: 2nd Side	*ENG	
[Special 1: Edge-Env. Correct] DFU			
017	Separation DC: Standard: 1st Side	*ENG	[1 to 100 / 50 / 1 /step]
018	Separation DC: Standard: 2nd Side	*ENG	
019	Separation DC: Low: 1st Side	*ENG	
020	Separation DC: Low: 2nd Side	*ENG	

2801	[Special 2: Bias]		
	Adjusts the DC voltage of the discharge plate for special paper 2. Middle: 182 mm/sec, Low: 85 mm/sec		

001	Separation DC: Middle Spd: 1st Side	*ENG	[0 to 6000 / 2000 / 10 -V /step]
002	Separation DC: Middle Spd: 2nd Side	*ENG	
003	Separation DC: Low Spd: 1st Side	*ENG	
004	Separation DC: Low Spd: 2nd Side	*ENG	

2803	[Special 2: Bias: BW]			
	Adjusts the current for the paper transfer roller for special paper 2 in black-and-white mode. Middle: 182 mm/sec, Low: 85 mm/sec			
	001	Paper Transfer: Middle: 1st Side	*ENG	[0 to 230 / 15 / 1 -µA /step]
	002	Paper Transfer: Middle: 2nd Side	*ENG	
	003	Paper Transfer: Low: 1st Side	*ENG	[0 to 230 / 9 / 1 -µA /step]
004	Paper Transfer: Low: 2nd Side	*ENG	[0 to 230 / 12 / 1 -µA /step]	

2807	[Special 2: Bias: FC]			
	Adjusts the current for the paper transfer roller for special paper 2 in full color mode. Middle: 182 mm/sec, Low: 85 mm/sec			
	001	Paper Transfer: Middle: 1st Side	*ENG	[0 to 230 / 24 / 1 -µA /step]
	002	Paper Transfer: Middle: 2nd Side	*ENG	
	003	Paper Transfer: Low: 1st Side	*ENG	[0 to 230 / 12 / 1 -µA /step]
004	Paper Transfer: Low: 2nd Side	*ENG	[0 to 230 / 18 / 1 -µA /step]	

2811	[Special 2: Size Correct: BW]		
	Adjusts the size correction coefficient for the paper transfer roller current for each paper size. SP2803 and SP2807 are multiplied by these SP values. Middle: 182 mm/sec, Low: 85mm/sec		

001	Paper Transfer: Middle: 1Side: S1	*ENG	[100 to 995 / 100 / 5%/step] S1 size \geq 194 mm (Paper width)
002	Paper Transfer: Middle: 2Side: S1	*ENG	
003	Paper Transfer: Low: 1 Side: S1	*ENG	
004	Paper Transfer: Low: 2 Side: S1	*ENG	
005	Paper Transfer: Middle: 1Side: S2	*ENG	[100 to 995 / 150 / 5%/step] 194 mm > S2 size \geq 165 mm (Paper width)
006	Paper Transfer: Middle: 2Side: S2	*ENG	[100 to 995 / 160 / 5%/step] 194 mm > S2 size \geq 165 mm (Paper width)
007	Paper Transfer: Low: 1 Side: S2	*ENG	[100 to 995 / 150 / 5%/step] 194 mm > S2 size \geq 165 mm (Paper width)
008	Paper Transfer: Low: 2 Side: S2	*ENG	[100 to 995 / 160 / 5%/step] 194 mm > S2 size \geq 165 mm (Paper width)
009	Paper Transfer: Middle: 1Side: S3	*ENG	[100 to 995 / 150 / 5%/step] 165 mm > S3 size \geq 139 mm (Paper width)
010	Paper Transfer: Middle: 2Side: S3	*ENG	[100 to 995 / 270 / 5%/step] 165 mm > S3 size \geq 139 mm (Paper width)
011	Paper Transfer: Low: 1 Side: S3	*ENG	[100 to 995 / 150 / 5%/step] 165 mm > S3 size \geq 139 mm (Paper width)
012	Paper Transfer: Low: 2 Side: S3	*ENG	[100 to 995 / 270 / 5%/step] 165 mm > S3 size \geq 139 mm (Paper width)
013	Paper Transfer: Middle: 1Side: S4	*ENG	[100 to 995 / 200 / 5%/step] 139 mm > S4 (Paper width)

014	Paper Transfer: Middle: 2Side: S4	*ENG	[100 to 995 / 435 / 5%/step] 139 mm > S4 (Paper width)
015	Paper Transfer: Low: 1 Side: S4	*ENG	[100 to 995 / 200 / 5%/step] 139 mm > S4 (Paper width)
016	Paper Transfer: Low: 2 Side: S4	*ENG	[100 to 995 / 435 / 5%/step] 139 mm > S4 (Paper width)

2812	[Special 2: Size Correct: FC]		
	Adjusts the size correction coefficient for the paper transfer roller current for each paper size. SP2803 and SP2807 are multiplied by these SP values. Middle: 182 mm/sec, Low: 85mm/sec		
	001	Paper Transfer: Middle: 1Side: S1	*ENG
	002	Paper Transfer: Middle: 2Side: S1	*ENG
	003	Paper Transfer: Low: 1 Side: S1	*ENG
004	Paper Transfer: Low: 2 Side: S1	*ENG	[100 to 995 / 100 / 5%/step] S1 size ≥ 194 mm (Paper width)
005	Paper Transfer: Middle: 1Side: S2	*ENG	[100 to 995 / 150 / 5%/step] 194 mm > S2 size ≥ 165 mm (Paper width)
006	Paper Transfer: Middle: 2Side: S2	*ENG	[100 to 995 / 160 / 5%/step] 194 mm > S2 size ≥ 165 mm (Paper width)
007	Paper Transfer: Low: 1 Side: S2	*ENG	[100 to 995 / 150 / 5%/step] 194 mm > S2 size ≥ 165 mm (Paper width)
008	Paper Transfer: Low: 2 Side: S2	*ENG	[100 to 995 / 160 / 5%/step] 194 mm > S2 size ≥ 165 mm (Paper width)
009	Paper Transfer: Middle: 1Side: S3	*ENG	[100 to 995 / 150 / 5%/step] 165 mm > S3 size ≥ 139 mm (Paper width)

010	Paper Transfer: Middle: 2Side: S3	*ENG	[100 to 995 / 270 / 5%/step] 165 mm > S3 size ≥ 139 mm (Paper width)
011	Paper Transfer: Low: 1 Side: S3	*ENG	[100 to 995 / 150 / 5%/step] 165 mm > S3 size ≥ 139 mm (Paper width)
012	Paper Transfer: Low: 2 Side: S3	*ENG	[100 to 995 / 270 / 5%/step] 165 mm > S3 size ≥ 139 mm (Paper width)
013	Paper Transfer: Middle: 1Side: S4	*ENG	[100 to 995 / 200 / 5%/step] 139 mm > S4 (Paper width)
014	Paper Transfer: Middle: 2Side: S4	*ENG	[100 to 995 / 435 / 5%/step] 139 mm > S4 (Paper width)
015	Paper Transfer: Low: 1 Side: S4	*ENG	[100 to 995 / 200 / 5%/step] 139 mm > S4 (Paper width)
016	Paper Transfer: Low: 2 Side: S4	*ENG	[100 to 995 / 435 / 5%/step] 139 mm > S4 (Paper width)

2813	[Special 2: Size Env. Correct: BW]		
	Adjusts the size correction coefficient for the paper transfer roller current for each paper size. SP2803 and SP2807 are multiplied by these SP values. Middle: 182 mm/sec, Low: 85mm/sec		
001	Paper Transfer: Middle: 1Side: S1	*ENG	[1 to 100 / 20 / 1 /step] S1 size ≥ 194 mm (Paper width)
002	Paper Transfer: Middle: 2Side: S1	*ENG	[1 to 100 / 19 / 1 /step] S1 size ≥ 194 mm (Paper width)
003	Paper Transfer: Low: 1 Side: S1	*ENG	[1 to 100 / 18 / 1 /step] S1 size ≥ 194 mm (Paper width)
004	Paper Transfer: Low: 2 Side: S1	*ENG	[1 to 100 / 23 / 1 /step] S1 size ≥ 194 mm (Paper width)

005	Paper Transfer: Middle: 1Side: S2	*ENG	[1 to 100 / 20 / 1 /step] 194 mm > S2 size ≥ 165 mm (Paper width)
006	Paper Transfer: Middle: 2Side: S2	*ENG	[1 to 100 / 19 / 1 /step] 194 mm > S2 size ≥ 165 mm (Paper width)
007	Paper Transfer: Low: 1 Side: S2	*ENG	[1 to 100 / 18 / 1 /step] 194 mm > S2 size ≥ 165 mm (Paper width)
008	Paper Transfer: Low: 2 Side: S2	*ENG	[1 to 100 / 23 / 1 /step] 194 mm > S2 size ≥ 165 mm (Paper width)
009	Paper Transfer: Middle: 1Side: S3	*ENG	[1 to 100 / 20 / 1 /step] 165 mm > S3 size ≥ 139 mm (Paper width)
010	Paper Transfer: Middle: 2Side: S3	*ENG	[1 to 100 / 19 / 1 /step] 165 mm > S3 size ≥ 139 mm (Paper width)
011	Paper Transfer: Low: 1 Side: S3	*ENG	[1 to 100 / 18 / 1 /step] 165 mm > S3 size ≥ 139 mm (Paper width)
012	Paper Transfer: Low: 2 Side: S3	*ENG	[1 to 100 / 23 / 1 /step] 165 mm > S3 size ≥ 139 mm (Paper width)
013	Paper Transfer: Middle: 1Side: S4	*ENG	[1 to 100 / 20 / 1 /step] 139 mm > S4 (Paper width)
014	Paper Transfer: Middle: 2Side: S4	*ENG	[1 to 100 / 19 / 1 /step] 139 mm > S4 (Paper width)
015	Paper Transfer: Low: 1 Side: S4	*ENG	[1 to 100 / 18 / 1 /step] 139 mm > S4 (Paper width)

016	Paper Transfer: Low: 2 Side: S4	*ENG	[1 to 100 / 23 / 1 /step] 139 mm > S4 (Paper width)
-----	---------------------------------	------	---

2814	[Special 2: Size Env. Correct: FC]		
	Adjusts the size correction coefficient for the paper transfer roller current for each paper size. SP2803 and SP2807 are multiplied by these SP values. Middle: 182 mm/sec, Low: 85mm/sec		
001	Paper Transfer: Middle: 1Side: S1	*ENG	[1 to 100 / 2 / 1 /step] S1 size ≥ 194 mm (Paper width)
002	Paper Transfer: Middle: 2Side: S1	*ENG	[1 to 100 / 31 / 1 /step] S1 size ≥ 194 mm (Paper width)
003	Paper Transfer: Low: 1 Side: S1	*ENG	[1 to 100 / 13 / 1 /step] S1 size ≥ 194 mm (Paper width)
004	Paper Transfer: Low: 2 Side: S1	*ENG	[1 to 100 / 25 / 1 /step] S1 size ≥ 194 mm (Paper width)
005	Paper Transfer: Middle: 1Side: S2	*ENG	[1 to 100 / 2 / 1 /step] 194 mm > S2 size ≥ 165 mm (Paper width)
006	Paper Transfer: Middle: 2Side: S2	*ENG	[1 to 100 / 31 / 1 /step] 194 mm > S2 size ≥ 165 mm (Paper width)
007	Paper Transfer: Low: 1 Side: S2	*ENG	[1 to 100 / 13 / 1 /step] 194 mm > S2 size ≥ 165 mm (Paper width)
008	Paper Transfer: Low: 2 Side: S2	*ENG	[1 to 100 / 25 / 1 /step] 194 mm > S2 size ≥ 165 mm (Paper width)
009	Paper Transfer: Middle: 1Side: S3	*ENG	[1 to 100 / 2 / 1 /step] 165 mm > S3 size ≥ 139 mm (Paper width)

010	Paper Transfer: Middle: 2Side: S3	*ENG	[1 to 100 / 31 / 1 /step] 165 mm > S3 size ≥ 139 mm (Paper width)
011	Paper Transfer: Low: 1 Side: S3	*ENG	[1 to 100 / 13 / 1 /step] 165 mm > S3 size ≥ 139 mm (Paper width)
012	Paper Transfer: Low: 2 Side: S3	*ENG	[1 to 100 / 25 / 1 /step] 165 mm > S3 size ≥ 139 mm (Paper width)
013	Paper Transfer: Middle: 1Side: S4	*ENG	[1 to 100 / 2 / 1 /step] 139 mm > S4 (Paper width)
014	Paper Transfer: Middle: 2Side: S4	*ENG	[1 to 100 / 31 / 1 /step] 139 mm > S4 (Paper width)
015	Paper Transfer: Low: 1 Side: S4	*ENG	[1 to 100 / 13 / 1 /step] 139 mm > S4 (Paper width)
016	Paper Transfer: Low: 2 Side: S4	*ENG	[1 to 100 / 25 / 1 /step] 139 mm > S4 (Paper width)

2821	[Special 2: L-Edge Correction] Special 2 Paper: Leading Edge Correction
	Adjusts the correction to the paper transfer roller current at the paper leading edge in each mode. SP2803 and SP2807 are multiplied by these SP values. Middle: 182 mm/sec, Low: 85 mm/sec Note <ul style="list-style-type: none"> The paper leading edge area can be adjusted with SP2822.

001	Paper Transfer: Middle: 1st Side	*ENG	[0 to 995 / 100 / 5%/step]
002	Paper Transfer: Middle: 2nd Side	*ENG	
003	Paper Transfer: Low: 1st Side	*ENG	
004	Paper Transfer: Low: 2nd Side	*ENG	
005	Separation DC: Middle: 1st Side	*ENG	
006	Separation DC: Middle: 2nd Side	*ENG	
007	Separation DC: Low: 1st Side	*ENG	
008	Separation DC: Low: 2nd Side	*ENG	

2822	[Special 2: Switch Timing: L-Edge]		
	Adjusts the bias/ voltage switch timing of the paper transfer roller/ discharge plate at the paper leading edge between the erase margin area and the image area. Middle: 182 mm/sec, Low: 85 mm/sec		
001	Paper Transfer: Middle: 1st Side	*ENG	[0 to 50 / 0 / 2 mm/step]
002	Paper Transfer: Middle: 2nd Side	*ENG	
003	Paper Transfer: Low: 1st Side	*ENG	
004	Paper Transfer: Low: 2nd Side	*ENG	
005	Separation DC: Middle: 1st Side	*ENG	
006	Separation DC: Middle: 2nd Side	*ENG	
007	Separation DC: Low: 1st Side	*ENG	
008	Separation DC: Low: 2nd Side	*ENG	

2823	[Special 2: T-Edge Correct]		
	Special 2 Paper: Trailing Edge Correction		
Adjusts the correction to the paper transfer roller current for the paper trailing edge in each mode. SP2803 and SP2807 are multiplied by these SP values. Middle: 182 mm/sec, Low: 85 mm/sec			
<div style="border: 1px solid black; border-radius: 15px; padding: 2px; display: inline-block;"> ↓ Note </div> <ul style="list-style-type: none"> • The paper trailing edge area can be adjusted with SP2824. 			
001	Paper Transfer: Middle: 1st Side	*ENG	[0 to 995 / 100 / 5%/step]
002	Paper Transfer: Middle: 2nd Side	*ENG	
003	Paper Transfer: Low: 1st Side	*ENG	
004	Paper Transfer: Low: 2nd Side	*ENG	
005	Separation DC: Middle: 1st Side	*ENG	
006	Separation DC: Middle: 2nd Side	*ENG	
007	Separation DC: Low: 1st Side	*ENG	
008	Separation DC: Low: 2nd Side	*ENG	

2824	[Special 2: Switch Timing: T-Edge]		
	Adjusts the bias/voltage switch timing of the paper transfer roller/discharge plate at the paper trailing edge between the erase margin area and the image area. Middle: 182 mm/sec, Low: 85 mm/sec		
001	Paper Transfer: Middle: 1st Side	*ENG	[0 to 50 / 0 / 2 mm/step]
002	Paper Transfer: Middle: 2nd Side	*ENG	
003	Paper Transfer: Low: 1st Side	*ENG	
004	Paper Transfer: Low: 2nd Side	*ENG	
005	Separation DC: Middle: 1st Side	*ENG	
006	Separation DC: Middle: 2nd Side	*ENG	
007	Separation DC: Low: 1st Side	*ENG	
008	Separation DC: Low: 2nd Side	*ENG	

2830	[Special 2: Env. Correct Table]		
	Middle: 182 mm/sec, Low: 85 mm/sec		
	013	Separation DC: Middle: 1st Side	*ENG
	014	Separation DC: Middle: 2nd Side	*ENG
	015	Separation DC: Low: 1st Side	*ENG
016	Separation DC: Low: 2nd Side	*ENG	
[Special 2: Edge-Env. Correct]			
017	Separation DC: Middle: 1st Side	*ENG	[1 to 100 / 30 / 1 /step]
018	Separation DC: Middle: 2nd Side	*ENG	
019	Separation DC: Low: 1st Side	*ENG	
020	Separation DC: Low: 2nd Side	*ENG	

System SP2-xxx: 6

SP2-XXX (Drum)

2851	[Special 3: Bias]		
	Adjusts the DC voltage of the discharge plate for special paper 3. Low: 85 mm/sec		
003	Separation DC: Low Spd: 1st Side	*ENG	[0 to 6000 / 2000 / 10 -V/step]
004	Separation DC: Low Spd: 2nd Side	*ENG	

5

2852	[Special 3: Bias: BW]		
	Adjusts the current for the paper transfer roller for special paper 3 in black-and-white mode. Low: 85 mm/sec		
003	Paper Transfer: Low: 1st Side	*ENG	[0 to 230 / 9 / 1 - μ A /step]
004	Paper Transfer: Low: 2nd Side	*ENG	[0 to 230 / 12 / 1 - μ A /step]

2857	[Special 3: Bias: FC]		
	Adjusts the current for the paper transfer roller for special paper 3 in full color mode. Low: 85 mm/sec		
003	Paper Transfer: Low: 1st Side	*ENG	[0 to 230 / 12 / 1 - μ A /step]
004	Paper Transfer: Low: 2nd Side	*ENG	[0 to 230 / 18 / 1 - μ A /step]

2861	[Special 3: Size Correct: BW]		
	Adjusts the size correction coefficient for the paper transfer roller current for each paper size. SP2852 and SP2857 are multiplied by these SP values. Low: 85mm/sec		
001	Paper Transfer: Low: 1 Side: S1	*ENG	[100 to 995 / 100 / 5%/step]
002	Paper Transfer: Low: 2 Side: S1	*ENG	S1 size \geq 194 mm (Paper width)

003	Paper Transfer: Low: 1 Side: S2	*ENG	[100 to 995 / 150 / 5%/step] 194 mm > S2 size ≥ 165 mm (Paper width)
004	Paper Transfer: Low: 2 Side: S2	*ENG	[100 to 995 / 160 / 5%/step] 194 mm > S2 size ≥ 165 mm (Paper width)
005	Paper Transfer: Low: 1 Side: S3	*ENG	[100 to 995 / 150 / 5%/step] 165 mm > S3 size ≥ 139 mm (Paper width)
006	Paper Transfer: Low: 2 Side: S3	*ENG	[100 to 995 / 270 / 5%/step] 165 mm > S3 size ≥ 139 mm (Paper width)
007	Paper Transfer: Low: 1 Side: S4	*ENG	[100 to 995 / 200 / 5%/step] 139 mm > S4 (Paper width)
008	Paper Transfer: Low: 2 Side: S4	*ENG	[100 to 995 / 435 / 5%/step] 139 mm > S4 (Paper width)

2862	[Special 3: Size Correction: FC]		
	Adjusts the size correction coefficient for the paper transfer roller current for each paper size. SP2852 and SP2857 are multiplied by these SP values. Low: 85mm/sec		
001	Paper Transfer: Low: 1 Side: S1	*ENG	[100 to 995 / 100 / 5%/step]
002	Paper Transfer: Low: 2 Side: S1	*ENG	S1 size ≥ 194 mm (Paper width)
003	Paper Transfer: Low: 1 Side: S2	*ENG	[100 to 995 / 150 / 5%/step] 194 mm > S2 size ≥ 165 mm (Paper width)
004	Paper Transfer: Low: 2 Side: S2	*ENG	[100 to 995 / 160 / 5%/step] 194 mm > S2 size ≥ 165 mm (Paper width)

005	Paper Transfer: Low: 1 Side: S3	*ENG	[100 to 995 / 150 / 5%/step] 165 mm > S3 size ≥ 139 mm (Paper width)
006	Paper Transfer: Low: 2 Side: S3	*ENG	[100 to 995 / 270 / 5%/step] 165 mm > S3 size ≥ 139 mm (Paper width)
007	Paper Transfer: Low: 1 Side: S4	*ENG	[100 to 995 / 200 / 5%/step] 139 mm > S4 (Paper width)
008	Paper Transfer: Low: 2 Side: S4	*ENG	[100 to 995 / 435 / 5%/step] 139 mm > S4 (Paper width)

5

2863	[Special 3: Size Env. Correct: BW]		
	Adjusts the size correction coefficient for the paper transfer roller current for each paper size. SP2852 and SP2857 are multiplied by these SP values. Low: 85mm/sec		
001	Paper Transfer: Low: 1 Side: S1	*ENG	[1 to 100 / 24 / 1 /step] S1 size ≥ 194 mm (Paper width)
002	Paper Transfer: Low: 2 Side: S1	*ENG	[1 to 100 / 22 / 1 /step] S1 size ≥ 194 mm (Paper width)
003	Paper Transfer: Low: 1 Side: S2	*ENG	[1 to 100 / 24 / 1 /step] 194 mm > S2 size ≥ 165 mm (Paper width)
004	Paper Transfer: Low: 2 Side: S2	*ENG	[1 to 100 / 22 / 1 /step] 194 mm > S2 size ≥ 165 mm (Paper width)
005	Paper Transfer: Low: 1 Side: S3	*ENG	[1 to 100 / 24 / 1 /step] 165 mm > S3 size ≥ 139 mm (Paper width)
006	Paper Transfer: Low: 2 Side: S3	*ENG	[1 to 100 / 22 / 1 /step] 165 mm > S3 size ≥ 139 mm (Paper width)

007	Paper Transfer: Low: 1 Side: S4	*ENG	[1 to 100 / 24 / 1 /step] 139 mm > S4 (Paper width)
008	Paper Transfer: Low: 2 Side: S4	*ENG	[1 to 100 / 22 / 1 /step] 139 mm > S4 (Paper width)

2864	[Special 3: Size Env. Correct: FC]		
	Adjusts the size correction coefficient for the paper transfer roller current for each paper size. SP2852 and SP2857 are multiplied by these SP values. Low: 85mm/sec		
001	Paper Transfer: Low: 1 Side: S1	*ENG	[1 to 100 / 24 / 1 /step] S1 size ≥ 194 mm (Paper width)
002	Paper Transfer: Low: 2 Side: S1	*ENG	[1 to 100 / 27 / 1 /step] S1 size ≥ 194 mm (Paper width)
003	Paper Transfer: Low: 1 Side: S2	*ENG	[1 to 100 / 24 / 1 /step] 194 mm > S2 size ≥ 165 mm (Paper width)
004	Paper Transfer: Low: 2 Side: S2	*ENG	[1 to 100 / 27 / 1 /step] 194 mm > S2 size ≥ 165 mm (Paper width)
005	Paper Transfer: Low: 1 Side: S3	*ENG	[1 to 100 / 24 / 1 /step] 165 mm > S3 size ≥ 139 mm (Paper width)
006	Paper Transfer: Low: 2 Side: S3	*ENG	[1 to 100 / 27 / 1 /step] 165 mm > S3 size ≥ 139 mm (Paper width)
007	Paper Transfer: Low: 1 Side: S4	*ENG	[1 to 100 / 24 / 1 /step] 139 mm > S4 (Paper width)
008	Paper Transfer: Low: 2 Side: S4	*ENG	[1 to 100 / 27 / 1 /step] 139 mm > S4 (Paper width)

2871	[Special 3: L-Edge Correction] Special 3 Paper: Leading Edge Correction			
	Adjusts the correction to the paper transfer roller current at the paper leading edge in each mode. SP2852 and SP2857 are multiplied by these SP values. Low: 85 mm/sec			
	<div style="border: 1px solid blue; border-radius: 15px; padding: 2px; display: inline-block;"> Note </div> <ul style="list-style-type: none"> • The paper leading edge area can be adjusted with SP2872. 			
	003	Paper Transfer: Low: 1st Side	*ENG	[0 to 995 / 100 / 5%/step]
	004	Paper Transfer: Low: 2nd Side	*ENG	
007	Separation DC: Low: 1st Side	*ENG		
008	Separation DC: Low: 2nd Side	*ENG		

2872	[Special 3: Switch Timing: L-Edge]			
	Adjusts the bias/ voltage switch timing of the paper transfer roller/ discharge plate at the paper leading edge between the erase margin area and the image area. Low: 85 mm/sec			
	003	Paper Transfer: Low: 1st Side	*ENG	[0 to 50 / 0 / 2 mm/step]
	004	Paper Transfer: Low: 2nd Side	*ENG	
	007	Separation DC: Low: 1st Side	*ENG	
008	Separation DC: Low: 2nd Side	*ENG		

2873	[Special 3: T-Edge Correction] Special 3 Paper: Trailing Edge Correction		
	Adjusts the correction to the paper transfer roller current for the paper trailing edge in each mode. SP2852 and SP2857 are multiplied by these SP values. Low: 85 mm/sec		
	<div style="border: 1px solid blue; border-radius: 15px; padding: 2px; display: inline-block;"> Note </div> <ul style="list-style-type: none"> • The paper trailing edge area can be adjusted with SP2874. 		

003	Paper Transfer: Low: 1st Side	*ENG	[0 to 995 / 100 / 5%/step]
004	Paper Transfer: Low: 2nd Side	*ENG	
007	Separation DC: Low: 1st Side	*ENG	
008	Separation DC: Low: 2nd Side	*ENG	

2874	[Special 3: Switch Timing: T-Edge]		
	Adjusts the bias/voltage switch timing of the paper transfer roller/discharge plate at the paper trailing edge between the erase margin area and the image area. Low: 85 mm/sec		
003	Paper Transfer: Low: 1st Side	*ENG	[0 to 50 / 0 / 2 mm/step]
004	Paper Transfer: Low: 2nd Side	*ENG	
007	Separation DC: Low: 1st Side	*ENG	
008	Separation DC: Low: 2nd Side	*ENG	

2880	[Special 3: Env. Correction Table]		
	Low: 85 mm/sec		
015	Separation DC: Low: 1st Side	*ENG	[1 to 100 / 30 / 1 /step]
016	Separation DC: Low: 2nd Side	*ENG	
[Special 3: Edge-Env. Correct]			
019	Separation DC: Low: 1st Side	*ENG	[1 to 100 / 30 / 1 /step]
020	Separation DC: Low: 2nd Side	*ENG	

2904	[Reverse Time]		
	Adjusts the time for how long the image transfer belt motor reverses after job end.		
003	Transfer All	*ENG	[0 to 800 / 70 / 10 msec/step]

2906	[Drum]		
-------------	---------------	--	--

001	Y Phase Angle	*ENG	[0 to 359 / 0 / 1 deg/step]
002	M Phase Angle	*ENG	
003	C Phase Angle	*ENG	
004	K Phase Angle	*ENG	
005	Color Phase Angle	*ENG	

[Drum Amplitude Setting]

006	Y Amp Setting	*ENG	[0 to 100 / 0 / 0.1 μm/step]
007	M Amp Setting	*ENG	
008	C Amp Setting	*ENG	
009	K Amp Setting	*ENG	
010	Color Amp Setting	*ENG	

[Drum Stop Position]

011	K Stop Positon	*ENG	[0 to 359 / 0 / 1 deg/step]
012	Color Stop Positon	*ENG	

2907	[FC: ACS]		
	<p>Adjusts the threshold for moving away the image transfer belt from the color PCUs. This SP moves the image transfer belt away from the color PCUs when the number of B/W image printouts reaches the number of sheets specified with this SP after consecutive full color image printouts in the full color mode.</p> <p>If this SP is set to "0", the image transfer belt does not move away.</p>		
001	Bk Image Count	*ENG	[0 to 10 / 0 / 1 sheet/step]

2911	[Offset Phase]		
001	Y Drum	*ENG	[0 to 359 / 0 / 1 deg/step]
002	M Drum	*ENG	
003	C Drum	*ENG	
004	K Drum	*ENG	

2912	[Offset Gain]		
001	Y Drum	*ENG	[0 to 100 / 0 / 0.1 $\mu\text{m}/\text{step}$]
002	M Drum	*ENG	
003	C Drum	*ENG	
004	K Drum	*ENG	

2960	[Process Interval]		
001	Additional Time	*ENG	[0 to 10 / 1 / 1 sec/step]

System SP3-xxx: 1

SP3-XXX (Process)

3011	[Process Cont. Manual Execution]		
001	Normal	-	<p>[0 or 1 / 0 / 1 /step]</p> <p>Executes the normal process control manually (potential control). Check the result with SP3-325-001 after executing this SP.</p>
002	Density Adjustment	-	<p>[0 or 1 / 0 / 1 /step]</p> <p>Executes the toner density adjustment manually. Check the result with SP3-325-001 after executing this SP.</p>
003	Pre-ACC	-	<p>[0 or 1 / 0 / 1 /step]</p> <p>Executes the process control that is normally done before ACC. The type of process control is selected with SP3-041-004.</p>
004	Full MUSIC	-	<p>[0 or 1 / 0 / 1 /step]</p> <p>Executes the process control that is normally done at the same time as MUSIC. This SP does the MUSIC (line position adjustment) twice.</p>
005	Normal MUSIC	-	<p>[0 or 1 / 0 / 1 /step]</p> <p>Executes the process control that is normally done at the same time as MUSIC. This SP does the MUSIC (line position adjustment) once.</p>

3012	[Process Cont. Check Result] Process Control Self-check Result		
	<p>Displays the result of the latest process control self-check.</p> <p>All colors are displayed. The results are displayed in the order "Y C M K" e.g., 11 (Y) 99 (C) 11 (M) 11 (K): The self-check for Cyan failed but the others were successful.</p> <p>See the "Error Condition Tables" in the Process Control Error section for details.</p>		
001	History: Latest	*ENG	[1111 to 99999999 / - / 1/step]
002	Result: Latest 1	*ENG	
003	Result: Latest 2	*ENG	
004	Result: Latest 3	*ENG	
005	Result: Latest 4	*ENG	
006	Result: Latest 5	*ENG	
007	Result: Latest 6	*ENG	
008	Result: Latest 7	*ENG	
009	Result: Latest 8	*ENG	
010	Result: Latest 9	*ENG	

3013	[T Sensor Initial Set: Exe] Developer Initialization Setting		
001	Execution: ALL	-	Executes the developer initialization for each color.
002	Execution: COL	-	
003	Execution: Bk	-	
004	Execution: C	-	
005	Execution: M	-	
006	Execution: Y	-	

007	Exe: MDL_B_182 ALL	-	Executes the developer initialization for each color.
008	Exe: MDL_B_182 COL	-	
009	Exe: MDL_B_182 Bk	-	
010	Exe: MDL_B_182 C	-	
011	Exe: MDL_B_182 M	-	
012	Exe: MDL_B_182 Y	-	

3014	[T Sensor Initial Set: Result] Developer Initialization Result: Display		
001	Display: latest YMCK	*ENG	[0 to 9999 / - / 1 /step]
002	Display: 260 YMCK	*ENG	1: Success
003	Display: 182 YMCK	*ENG	2 to 9: Failure
<p>Displays the developer initialization result. See the "Error Condition Tables" in the Process Control Error section for details on the meaning of each code.</p> <p>All colors are displayed. Values are displayed in the order Y M C Bk. e.g., 1 (Y) 1 (M) 2 (C) 1 (Bk): Initialization of Cyan failed but the others succeeded.</p>			

3015	[Forced Toner Supply: Execute] Forced Toner Supply ([Color])		
001	Execution: ALL	-	[0 or 1 / 0 / 1 /step] Executes the manual toner supply to the development unit.
002	Execution: COL	-	
003	Execution: Bk	-	
004	Execution: C	-	
005	Execution: M	-	
006	Execution: Y	-	

3016	[Forced Toner Supply: Setting] Forced Toner Supply Setting ([Color])		
Specifies the manual toner supply time for each color.			

001	Supply Time: Bk	*ENG	[0 to 30 / 4 / 1 sec/step]
002	Supply Time: C	*ENG	
003	Supply Time: M	*ENG	
004	Supply Time: Y	*ENG	

3041	[Process Control Type]		
001	Voltage Control	*ENG	[0 or 1 / 1 / 1/step] Alphanumeric 0: FIXED (Use the fixed values for the charge DC bias and development DC bias set with SP2-005 and SP2-229.) 1: CONTROL
Enables or disables the process control.			
002	LD Power Control	*ENG	[0 or 1 / 1 / 1/step] Alphanumeric 0: FIXED (at the value in SP2221-xxx) 1: CONTROL (adjusted by process control)
Selects the LD power control mode.			
003	Auto Control Prohibition Set	*ENG	[0 or 1 / 0 / 1/step] 0: Permit, 1: Forbid
-			
004	Pre-ACC Process Control	*ENG	[0 to 2 / 2 / 1/step] 0: Not Execute 1: Process Control 2: TC Control
Selects the process control mode that is done before ACC.			
005	Pattern Calculation Method	*ENG	[0 to 2 / 0 / 1/step] 0: FIXED 1: INITIALIZED 2: CALCULATED

3043	[TD Adjustment Mode]		
-------------	-----------------------------	--	--

001	Repeat Number: Power ON	*ENG	[0 to 9 / 4 / 1 time/step]
	<p>Specifies the maximum number of repeats of the toner density adjustment at power on.</p> <p>0: Disabled, 1 to 3: Repeat number, 4: Repeat three times (No consumption mode) 5: Repeat three times (Toner is supplied only when the toner density is too low, and toner is consumed only when the toner density is too dark.) 6 to 9: Disabled</p>		
002	Repeat Number: Initialization	*ENG	[0 to 9 / 3 / 1 time/step]
	<p>Specifies the maximum number of repeats of the toner density adjustment at the developer initialization.</p> <p>0: Disabled, 1 to 3: Repeat number, 4: Repeat three times (No consumption mode) 5: Repeat three times (Toner is supplied only when the toner density is too low, and toner is consumed only when the toner density is too dark.) 6 to 9: Disabled</p>		
003	Repeat Number: Non-use	*ENG	[0 to 9 / 0 / 1 time/step]
	<p>Specifies the maximum number of repeats of the toner density adjustment in stand by mode.</p> <p>0: Disabled, 1 to 3: Repeat number, 4: Repeat three times (No consumption mode) 5: Repeat three times (Toner is supplied only when the toner density is too low, and toner is consumed only when the toner density is too dark.) 6 to 9: Disabled</p>		
004	Repeat Number: ACC	*ENG	[0 to 9 / 3 / 1 time/step]
	<p>Specifies the maximum number of repeats of the toner density adjustment at ACC.</p> <p>0: Disabled, 1 to 3: Repeat number, 4: Repeat three times (No consumption mode) 5: Repeat three times (Toner is supplied only when the toner density is too low, and toner is consumed only when the toner density is too dark.) 6 to 9: Disabled</p>		
005	Repeat Number: Recovery	*ENG	[0 to 9 / 3 / 1 time/step]
	Not used		

006	Repeat Number: Job End	*ENG	[0 to 9 / 4 / 1 time/step]
	<p>Specifies the maximum number of repeats of the toner density adjustment at job end.</p> <p>0: Disabled, 1 to 3: Repeat number, 4: Repeat three times (No consumption mode) 5: Repeat three times (Toner is supplied only when the toner density is too low, and toner is consumed only when the toner density is too dark.) 6 to 9: Disabled</p>		
007	Repeat Number:Interrupt	*ENG	[0 to 9 / 0 / 1 time/step]
	-		
018	Consumption Pattern: LD: DUTY: Bk	*ENG	[0 to 15 / 15 / 1 /step]
	<p>Adjusts the LD duty for the toner consumption mode at the toner density adjustment.</p> <p>In toner consumption mode, toner is discharged when the detected development gamma values (SP3611-001) exceed the target values (SP3611-005) by more than the specified thresholds (SP3239-009).</p>		
019	Consumption Pattern: LD: DUTY: C	*ENG	[0 to 15 / 15 / 1 /step]
	<p>Adjusts the LD duty for the toner consumption mode at the toner density adjustment.</p> <p>In toner consumption mode, toner is discharged when the detected development gamma values (SP3611-002) exceed the target values (SP3611-006) by more than the specified thresholds (SP3239-009).</p>		
020	Consumption Pattern: LD: DUTY: M	*ENG	[0 to 15 / 15 / 1 /step]
	<p>Adjusts the LD duty for the toner consumption mode at the toner density adjustment.</p> <p>In toner consumption mode, toner is discharged when the detected development gamma values (SP3611-003) exceed the target values (SP3611-007) by more than the specified thresholds (SP3239-009).</p>		
021	Consumption Pattern: LD: DUTY: Y	*ENG	[0 to 15 / 15 / 1 /step]
	<p>Adjusts the LD duty for the toner consumption mode at the toner density adjustment.</p> <p>In toner consumption mode, toner is discharged when the detected development gamma values (SP3611-004) exceed the target values (SP3611-008) by more than the specified thresholds (SP3239-009).</p>		

3044	[Toner Supply Type] Toner Supply Type ([Color])		
	Selects the toner supply method type.		
001	Bk	*ENG	[0 to 4 / 4 / 1/step] Alphanumeric
002	C	*ENG	0: FIXED (with the supply rates stored with SP 3401) 1: PID (Vtref_Fixed) 2: PID (Vtref_Control) 3: MBD (Vtref_Fixed) 4: MBD (Vtref_Control)
003	M	*ENG	
004	Y	*ENG	

3045	[Toner End Detection: Set] DFU		
	Enables/disables the toner alert display on the LCD.		
001	ON/OFF	*ENG	[0 or 1 / 0 / 1/step] 0: Detect, 1: Not Detect

3101	[Toner End/Near End] DFU		
	Displays the amount of each color toner.		
001	Toner Replenishment: Bk	*ENG	[1 to 600 / 240 / 1 g/step]
002	Toner Replenishment: C	*ENG	
003	Toner Replenishment: M	*ENG	
004	Toner Replenishment: Y	*ENG	
005-008	Displays the consumed amount of each color toner.		
005	Toner Consumption: Bk	*ENG	[0 to 3000 / 0 / 0.001 g/step]
006	Toner Consumption: C	*ENG	
007	Toner Consumption: M	*ENG	
008	Toner Consumption: Y	*ENG	
009-012	Displays the remaining amount of each color toner. These are calculated by the operating times of the toner supply pumps.		

009	Toner Remaining: Bk	*ENG	[-50000 to 600 / 0 / 0.001 g/step]
010	Toner Remaining: C	*ENG	
011	Toner Remaining: M	*ENG	
012	Toner Remaining: Y	*ENG	
013-016	Adjusts the threshold of toner near end for each color. The toner near end message appears on the LCD when the remaining toner amount reaches this threshold. When one of these SPs (SP3-101-009 to 012 or -032 to -035) reaches this threshold, toner near end is detected.		
013	Near End Thresh: Bk	*ENG	[0 to 600 / 45 / 1 g/step]
014	Near End Thresh: C	*ENG	
015	Near End Thresh: M	*ENG	
016	Near End Thresh: Y	*ENG	
032-035	Displays the remaining toner amount for each color, using pixel count.		
032	Pixel: Remaining : Bk	*ENG	[-50000 to 600 / 0 / 0.001 g/step]
033	Pixel: Remaining : C	*ENG	
034	Pixel: Remaining : M	*ENG	
035	Pixel: Remaining : Y	*ENG	

3102	[Toner End Recovery] DFU			
	Adjusts the number of times toner supply is attempted for each color when the TD sensor continues to detect toner end during toner recovery.			
	001	Repeat: Bk	*ENG	[1 to 20 / 5 / 1 time/step]
	002	Repeat: C	*ENG	
	003	Repeat: M	*ENG	
004	Repeat: Y	*ENG		

3201	[TD Sensor: Vt Display]		
	Display the current voltage of the TD sensor for each color.		

001	Current: Bk	*ENG	[0 to 5.5 / 0.01 / 0.01 V/step]
002	Current: C	*ENG	
003	Current: M	*ENG	
004	Current: Y	*ENG	

3221	[Vtcnt: Display/Set]		
	Displays or adjusts the current Vtcnt value for each color.		
001	260 Current: Bk	*ENG	[2.45 to 5 / 3.7 / 0.01 V/step]
002	260 Current: C	*ENG	
003	260 Current: M	*ENG	
004	260 Current: Y	*ENG	
009	182 Current: Bk	*ENG	[2.45 to 5 / 3.5 / 0.01 V/step]
010	182 Current: C	*ENG	
011	182 Current: M	*ENG	
012	182 Current: Y	*ENG	

3222	[Vtref: Display/Set]		
	Displays or adjusts the current Vtref value for each color.		
001	Current: Bk	*ENG	[0 to 5.5 / 3 / 0.01 V/step]
002	Current: C	*ENG	
003	Current: M	*ENG	
004	Current: Y	*ENG	

3230	[Toner Supply MBD] DFU		
008	MSEC_V	*ENG	[0 to 1 / 0.080 / 0.001 V/step]

3239	[Vtref Correction: Setting]		
	Adjusts the parameter for Vtref correction at the process control.		
001	(+)Consumption: Bk	*ENG	[0 to 1 / 0.08 / 0.01 V/step]
002	(+)Consumption: C	*ENG	
003	(+)Consumption: M	*ENG	
004	(+)Consumption: Y	*ENG	
005	(-)Consumption: Bk	*ENG	
006	(-)Consumption: C	*ENG	
007	(-)Consumption: M	*ENG	
008	(-)Consumption: Y	*ENG	
009-012	Threshold for development gamma rank.		
009	P Rank 1 Threshold	*ENG	[0 to 2 / 0.5 / 0.01 /step]
010	P Rank 2 Threshold	*ENG	[0 to 2 / 0.25 / 0.01 /step]
011	P Rank 3 Threshold	*ENG	[-2 to 0 / -0.25 / 0.01 /step]
012	P Rank 4 Threshold	*ENG	[-2 to 0 / -0.5 / 0.01 /step]
013-014	Threshold for image density rank on the image transfer belt.		
013	T Rank 1 Threshold	*ENG	[-1 to 0 / -0.16 / 0.01 V/step]
014	T Rank 2 Threshold	*ENG	[0 to 1 / 0.16 / 0.01 V/step]
015	Correct Value Coef	*ENG	[1 to 2.5 / 2.5 / 0.01 /step]

3242	[LD Power Setting]		
	Adjusts the coefficient for LD power control value at the process control.		
001	Standard Speed: Coefficient: Bk	*ENG	[-1000 to 1000 / 152 / 1 /step]
002	Standard Speed: Coefficient: C	*ENG	
003	Standard Speed: Coefficient: M	*ENG	
004	Standard Speed: Coefficient: Y	*ENG	

005	Standard Speed: Offset: Bk	* ENG	[-1000 to 1000 / 7 / 1 /step]
006	Standard Speed: Offset: C	* ENG	
007	Standard Speed: Offset: M	* ENG	
008	Standard Speed: Offset: Y	* ENG	
009	Middle Speed: Coef: Bk	* ENG	[-1000 to 1000 / 141 / 1 /step]
010	Middle Speed: Coef: C	* ENG	
011	Middle Speed: Coef: M	* ENG	
012	Middle Speed: Coef: Y	* ENG	
013	Middle Speed: Offset: Bk	* ENG	[-1000 to 1000 / 13 / 1 /step]
014	Middle Speed: Offset: C	* ENG	
015	Middle Speed: Offset: M	* ENG	
016	Middle Speed: Offset: Y	* ENG	
017	Low Speed Coeff.:Bk	* ENG	[-1000 to 1000 / 123 / 1 /step]
018	Low Speed Coeff.:C	* ENG	
019	Low Speed Coeff.:M	* ENG	
020	Low Speed Coeff.:Y	* ENG	
021	Low Speed Offset:Bk	* ENG	[-1000 to 1000 / 16 / 1 /step]
022	Low Speed Offset:C	* ENG	
023	Low Speed Offset:M	* ENG	
024	Low Speed Offset:Y	* ENG	

3251	[Coverage]
	These (-001 to -016) are coefficients for SP3-222-009 to -012.

001	Latest: Pixcel Bk	*ENG	Displays the latest coverage for each color. [0 to 9999 / 0 / 1 cm ² /step]
002	Latest: Pixcel C	*ENG	
003	Latest: Pixcel M	*ENG	
004	Latest: Pixcel Y	*ENG	
005-008	Displays the average coverage of each color for the Vtref correction. "Average S" is defined when the number of developed pages does not reach the number specified with SP3251-017.		
005	Average S: Bk	*ENG	[0 to 100 / 5 / 0.01 %/step]
006	Average S: C	*ENG	
007	Average S: M	*ENG	
008	Average S: Y	*ENG	
009-012	Displays the average coverage of each color for the Vtref correction. "Average M" is defined when the number of developed pages does not reach the number specified with SP3251-018.		
009	Average M: Bk	*ENG	[0 to 100 / 5 / 0.01 %/step]
010	Average M: C	*ENG	
011	Average M: M	*ENG	
012	Average M: Y	*ENG	
013-016	Displays the average coverage of each color for the Vtref correction. "Average L" is defined when the number of developed pages does not reach the number specified with SP3-251-019.		
013	Average L: Bk	*ENG	[0 to 100 / 5 / 0.01 %/step]
014	Average L: C	*ENG	
015	Average L: M	*ENG	
016	Average L: Y	*ENG	
017-019	Adjusts the threshold for SP3-251-005 to -016.		
017	Total Page Setting: S	*ENG	[1 to 100 / 50 / 1 sheet/step]

018	Total Page Setting: M	*ENG	[1 to 500 / 10 / 1 sheet/step]
019	Total Page Setting: L	*ENG	[1 to 999 / 50 / 1 sheet/step]
020-022	Adjusts the threshold for SP3-251-024 to -027.		
020	Total Page Setting: S2	*ENG	[1 to 100 / 20 / 1 sheet/step]
021	Total Page Setting: M2	*ENG	[1 to 500 / 10 / 1 sheet/step]
022	Total Page Setting: L2	*ENG	[1 to 999 / 50 / 1 sheet/step]
024-027	Displays the latest coverage ratio for each color.		
024	Latest Coverage: Bk	*ENG	[0 to 100 / - / 0.01 %/step]
025	Latest Coverage: C	*ENG	
026	Latest Coverage: M	*ENG	
027	Latest Coverage: Y	*ENG	

System SP3-xxx: 2

SP3-XXX (Process)

3311	[ID Sensor Detection Value: Voffset]		
	Displays the ID sensor (regular) offset voltage for Vsg adjustments.		
001	Voffset reg: Bk	* ENG	[0 to 5 / 0 / 0.01 V/step]
002	Voffset reg: C	* ENG	[0 to 5.5 / 0 / 0.01 V/step]
003	Voffset reg: M	* ENG	
004	Voffset reg: Y	* ENG	
005-007	Displays the ID sensor (diffusion) offset voltage for Vsg adjustments.		
005	Voffset dif: C	* ENG	[0 to 5.5 / 0 / 0.01 V/step]
006	Voffset dif: M	* ENG	
007	Voffset dif: Y	* ENG	
008-010	Displays the ID sensor offset voltage for Vsg adjustments.		
008	Voffset TM (Front)	* ENG	[0 to 5.5 / 0 / 0.01 V/step]
009	Voffset TM (Center)	* ENG	
010	Voffset TM (Rear)	* ENG	
3321	[Vsg Adjustment: Execution]		
010	P/TM Sensor All	-	Execute the ID sensor initialization setting for all sensors
3322	[Vsg Adjustment Result: Vsg]		
	Displays the result value of the Vsg adjustment for each sensor.		

001	Vsg reg: Bk	*ENG	[0 to 5.5 / 0 / 0.01 V/step]
002	Vsg reg: C	*ENG	
003	Vsg reg: M	*ENG	
004	Vsg reg: Y	*ENG	
005	Vsg dif: C	*ENG	
006	Vsg dif: M	*ENG	
007	Vsg dif: Y	*ENG	
008	Vsg TM (Front)	*ENG	
009	Vsg TM (Center)	*ENG	
010	Vsg TM (Rear)	*ENG	

3325	[Vsg Adjustment Result]		
	<p>Displays the result of the Vsg adjustment.</p> <p>The displayed numbers mean the result of each sensor (sensor for Front, sensor for Bk, sensor for Cyan, sensor for Center, sensor for Magenta, sensor for Yellow and sensor for Rear).</p>		
001	Latest	*ENG	[111 to 9999 / 9999 / 1 /step] 9: Unexpected error 3: Offset voltage error 2: Vsg adjustment value error 1: O.K
002	Latest 1	*ENG	
003	Latest 2	*ENG	
004	Latest 3	*ENG	
005	Latest 4	*ENG	
006	Latest 5	*ENG	
007	Latest 6	*ENG	
008	Latest 7	*ENG	
009	Latest 8	*ENG	
010	Latest 9	*ENG	

3363	[ID Pattern Timing Setting]		
------	------------------------------------	--	--

004	MUSIC Delay Time	*ENG	Adjusts the processing timing for the pattern that is used for the line position adjustment. [-2500 to 2500 / 300 / 1 msec/step]
-----	------------------	------	--

3401	[Fixed Supply Mode]		
	Adjusts the toner supply rate in the fixed toner supply mode.		
001	Fixed Rate: Bk	*ENG	[0 to 100 / 5 / 1 %/step] These SPs are used only when SP3-044 is set to "0".
002	Fixed Rate: C	*ENG	
003	Fixed Rate: M	*ENG	
004	Fixed Rate: Y	*ENG	

3411	[Toner Supply Rate: Display]		
	Displays the current toner supply rate.		
001	Latest: Bk	*ENG	[0 to 100 / - / 1 %/step]
002	Latest: C	*ENG	
003	Latest: M	*ENG	
004	Latest: Y	*ENG	

3421	[Toner Supply Range]		
001	Upper Limit: Bk	*ENG	Adjusts the toner supply rate during printing. [0 to 100 / 100 / 1%/step]
002	Upper Limit: C	*ENG	
003	Upper Limit: M	*ENG	
004	Upper Limit: Y	*ENG	
005	Minimum Supply Time: Bk	*ENG	Adjusts the minimum toner supply time. [0 to 1000 / 200 / 1 msec/step]
006	Minimum Supply Time: C	*ENG	
007	Minimum Supply Time: M	*ENG	
008	Minimum Supply Time: Y	*ENG	

3453	[Toner Supply: Set]		
	Adjusts the toner supply time.		
001	MtContinuousMax DriveTime	*ENG	[0 to 10000 / 800 / 1 msec/step]
002	Motor Break Time	*ENG	[0 to 10000 / 200 / 1 msec/step]

3501	[Process Control Target M/A]		
	Adjusts the target M/A of the full coverage in single color printer mode.		
001	Maximum M/A: Bk	*ENG	[0 to 1 / 0.482 / 0.001 mg/cm ² /step]
002	Maximum M/A: C	*ENG	[0 to 1 / 0.5 / 0.001 mg/cm ² /step]
003	Maximum M/A: M	*ENG	
004	Maximum M/A: Y	*ENG	

3510	[Image Quality Adj. Counter:Display]		
	Displays the total page counter for each adjustment mode.		
001	Process Control: BW	*ENG	[0 to 2000 / 0 / 1 page/step]
002	Process Control: FC	*ENG	
003	Power ON: BW	*ENG	
004	Power ON: FC	*ENG	
005	MUSIC: BW	*ENG	
006	MUSIC: FC	*ENG	
007	Vsg Adj.	*ENG	
008	Charge AC Control	*ENG	
009	MUSIC: Power ON: BW	*ENG	
010	MUSIC: Power ON: FC	*ENG	

3511	[Execution Interval: Setting]		
	Adjusts the threshold for each adjustment mode.		

001	Job End: Process Control: BW	*ENG	[0 to 2000 / 250 / 1 page/step]
002	Job End: Process Control: FC	*ENG	[0 to 2000 / 85 / 1 page/step]
003	Interrupt: Process Control: BW	*ENG	[0 to 2000 / 500 / 1 page/step]
004	Interrupt: Process Control: FC	*ENG	[0 to 2000 / 200 / 1 page/step]
005	Initial: Potential Control: BW	*ENG	[0 to 2000 / 250 / 1 page/step]
006	Initial: Potential Control: FC	*ENG	[0 to 2000 / 100 / 1 page/step]
007	Vsg Adj. Counter	*ENG	[0 to 2000 / 0 / 1 page/step]
008	Charge AC Control Counter	*ENG	[0 to 2000 / 500 / 1 page/step]
019	Envir. Correction	*ENG	[0 or 1 / 1 / 1 /step]
020	Gamma Correction	*ENG	0: Not Correct (OFF),
021	Non-use Time Correct	*ENG	1: Correct (ON)
022	Correction Coeff. 1: JE: BW	*ENG	[0 to 1 / 0.2 / 0.01 /step]
023	Correction Coeff. 2: JE: BW	*ENG	[0 to 1 / 1 / 0.01/step]
024	Correction Coeff. 1: JE: FC	*ENG	[0 to 1 / 0.59 / 0.01/step]
025	Correction Coeff. 2: JE: FC	*ENG	[0 to 1 / 1 / 0.01/step]
026	Correction Coeff. 1: Interrupt: BW	*ENG	[0 to 1 / 0.1 / 0.01/step]
027	Correction Coeff. 2: Interrupt: BW	*ENG	[0 to 1 / 1 / 0.01/step]
028	Correction Coeff. 1: Interrupt: FC	*ENG	[0 to 1 / 0.25 / 0.01/step]
029	Correction Coeff. 2: Interrupt: FC	*ENG	[0 to 1 / 1 / 0.01/step]
030	Max. Number Correction Threshold	*ENG	[0 to 99 / 5 / 1/step]
031	Max. Number Correction Counter	*ENG	[0 to 255 / 0 / 1/step]

3512	[Image Quality Adj.: Interval]		
	Adjusts the timing for execution of process control and line position adjustment during printing.		
001	During Job	*ENG	[0 to 100 / 10 / 1 page/step]

002	During Stand-by	*ENG	[0 to 100 / 10 / 1 minute/step]
-----	-----------------	------	---------------------------------

3513	[PCU Motor Stop Time: Bk]		
	Displays the last time that the PCU motors stopped. These are used for process control execution timing.		
001	Year	*ENG	[0 to 99 / 0 / 1/step]
002	Month	*ENG	[1 to 12 / 1 / 1/step]
003	Day	*ENG	[1 to 31 / 1 / 1/step]
004	Hour	*ENG	[0 to 23 / 0 / 1/step]
005	Minute	*ENG	[0 to 59 / 0 / 1/step]

5

3514	[Environmental Display: Job End]		
	Displays the environmental conditions at the last job. These are used for process control execution timing.		
001	Temperature	*ENG	[-1280 to 1270 / 0 / 0.1°C/step]
002	Relative Humidity	*ENG	[0 to 1000 / - / 0.1%RH/step]
003	Absolute Humidity	*ENG	[0 to 1000 / - / 0.1 g/cm ³ /step]

3515	[Execution Interval: Display]		
	Displays the current interval for process control execution. When the machine calculates the timing for process control, it uses a number of conditions. These are the results after considering all the conditions.		
001	Job End: Process Control: BW	*ENG	[0 to 2000 / 250 / 1 page/step]
002	Job End: Process Control: FC	*ENG	[0 to 2000 / 85 / 1 page/step]
003	Interrupt: Process Control: BW	*ENG	[0 to 2000 / 500 / 1 page/step]
004	Interrupt: Process Control: FC	*ENG	[0 to 2000 / 200 / 1 page/step]

3516	[Refresh Mode] DFU		
	While making prints with low coverage, the developer is agitated with less toner consumption and the toner carrier attraction tends to increase. This may cause low image density or poor transfer (white dots). To prevent this, the coagulated toner or overcharged toner has to be consumed by performing the refresh mode.		
001	Dev. Motor Rotation: Display: Bk	*ENG	[0 to 1000 / 0 / 0.1 m/step]
002	Dev. Motor Rotation: Display: C	*ENG	
003	Dev. Motor Rotation: Display: M	*ENG	
004	Dev. Motor Rotation: Display: Y	*ENG	
005	Rotation Threshold	*ENG	[0 to 1000 / 0.1 / 1 m/step]
006	Pixel Coverage Sum: Bk	*ENG	[0 to 65535 / 0 / 1 cm ² /step]
007	Pixel Coverage Sum: C	*ENG	
008	Pixel Coverage Sum: M	*ENG	
009	Pixel Coverage Sum: Y	*ENG	
010	Required Area: Bk	*ENG	
011	Required Area: C	*ENG	
012	Required Area: M	*ENG	
013	Required Area: Y	*ENG	
014	Refresh Threshold: Bk	*ENG	[0 to 255 / 35 / 1 cm ² /m/step]
015	Refresh Threshold: C	*ENG	[0 to 255 / 18 / 1 cm ² /m/step]
016	Refresh Threshold: M	*ENG	
017	Refresh Threshold: Y	*ENG	
018	Pattern Number: Bk	*ENG	[0 to 255 / 0 / 1 time/step]
019	Pattern Number: C	*ENG	
020	Pattern Number: M	*ENG	
021	Pattern Number: Y	*ENG	
022	Pattern Number: Upper limit	*ENG	[0 to 255 / 16 / 1 time/step]

023	Toner Consumption Pattern Area	*ENG	[10 to 2550 / 130 / 10 cm ² /step]
024	Supply Coefficient	*ENG	[0 to 2.55 / 0.8 / 0.01/step]
025	Job End Area Coefficient	*ENG	[0.1 to 25.5 / 1 / 0.1/step]
026	Job End Vb Coefficient	*ENG	[0 to 100 / 40 / 1%/step]
027	Job End Length	*ENG	[0 to 56 / 28 / 1mm/step]
028	Job End Supply	*ENG	[0 to 1 / 0.45 / 0.001 mg/cm ² /step]
029	TnCnsmp: Internal Thresh	*ENG	[0 to 1000 / 0 / 1 page/step]
030	TnCnsmp: Counter:Bk	*ENG	
031	TnCnsmp: Counter:FC	*ENG	
032	TnCnsmp: Internal Thresh 2	*ENG	[0 to 255 / 4 / 1 page/step]

3518	[Image Quality Adj.: Exe Flag] DFU		
008	MUSIC	*ENG	[0 to 2 / 0 / 1/step] 0: OFF. 1: ON (once), 2: ON (twice)
009	Drum Phase Adj.	*ENG	[0 or 1 / 0 / 1/step] 0: OFF. 1: ON

3520	[Transfer/ITB Idle Time] DFU		
001	Temperature: H	*ENG	Specifies the idle rotation times of the ITB after the process control. [0 or 3 / 1.9 / 1 revolution/step]
002	Temperature: M	*ENG	
003	Temperature: L	*ENG	
004	Temperature: L: ON	*ENG	
005 to 006	Adjusts the threshold temperature for entering the ITB idle rotation after the process control.		
005	Temperature Thresh:T2	*ENG	[20 or 30 / 25 / 1 deg/step]
006	Temperature Thresh:T1	*ENG	[0 or 15 / 15 / 1 deg/step]

3522	[Initial Process Control Set]		
	Adjusts the threshold for the process control at power on. When the current condition has changed by more than the values of these SPs when compared with the conditions at the previous operation, the process control at power on is executed.		
002	Non-use Time Setting	*ENG	[0 to 1440 / 360 / 1 minute/step]
003	Temperature Range	*ENG	[0 to 99 / 10 / 1 deg/step]
004	Relative Humidity Range	*ENG	[0 to 99 / 50 / 1 %RH/step]
005	Absolute Humidity Range	*ENG	[0 to 99 / 6 / 1 g/m ³ /step]

3531	[Non-use Time Process Control Set]		
	Adjusts the threshold for the process control at stand-by. When the current condition has changed by more than the values of these SPs when compared with the conditions at the previous operation, the process control at stand-by is executed.		
001	Non-use Time Setting	*ENG	[0 to 1440 / 360 / 1 minute/step]
002	Temperature Range	*ENG	[0 to 99 / 10 / 1 deg/step]
003	Relative Humidity Range	*ENG	[0 to 99 / 50 / 1 %RH/step]
004	Absolute Humidity Range	*ENG	[0 to 99 / 6 / 1 g/m ³ /step]
005	Maximum Execution Number	*ENG	Adjusts the maximum execution time for the process control at stand-by. [0 to 99 / 10 / 1 time/step]

3611	[Dev. Gamma: Display/Set]		
001	Bk (Current)	*ENG	Displays the current development gamma for Bk [0 to 5 / 0 / 0.01 mg/cm ² /kV /step]
002	C (Current)	*ENG	Displays the current development gamma for C/M/Y. [0 to 5 / 0 / 0.01 mg/cm ² /kV /step]
003	M (Current)	*ENG	
004	Y (Current)	*ENG	

005	Bk (Target Display)	*ENG	Displays the target development gamma for Bk. [0 to 5 / 0.85 / 0.01 mg/cm ² /kV /step]
006	C (Target Display)	*ENG	Displays the target development gamma for C/M/Y. [0 to 5 / 0.85 / 0.01 mg/cm ² /kV /step]
007	M (Target Display)	*ENG	[0 to 5 / 0.8 / 0.01 mg/cm ² /kV /step]
008	Y (Target Display)	*ENG	[0 to 5 / 0.77 / 0.01 mg/cm ² /kV /step]

3612	[Vk Display]		
	Displays Vk for each color.		
	001	Bk	*ENG
	002	C	*ENG
	003	M	*ENG
004	Y	*ENG	[-300 to 300 / 0 / 1 V/step]

3621	[Development DC Control:Display]		
	Standard: 260 mm/sec, Middle: 182 mm/sec, Low: 85 mm/sec		
Displays the development DC bias adjusted with the process control for each line speed and color.			

001	Standard Speed:Bk	*ENG	[0 to 800 / 550 / 1 -V/step]
002	Standard Speed:C	*ENG	
003	Standard Speed:M	*ENG	
004	Standard Speed:Y	*ENG	
005	Middle Speed:Bk	*ENG	
006	Middle Speed:C	*ENG	
007	Middle Speed:M	*ENG	
008	Middle Speed:Y	*ENG	
009	Low Speed:Bk	*ENG	
010	Low Speed:C	*ENG	
011	Low Speed:M	*ENG	
012	Low Speed:Y	*ENG	

3631	[Charge DC Control: Display] Standard: 260 mm/sec, Middle: 182 mm/sec, Low: 85 mm/sec
	Displays the charge DC voltage adjusted with the process control for each line speed and color.

001	Standard Speed:Bk	*ENG	[0 to 2000 / 690 / 1 -V/step]
002	Standard Speed:C	*ENG	
003	Standard Speed:M	*ENG	
004	Standard Speed:Y	*ENG	
005	Middle Speed:Bk	*ENG	
006	Middle Speed:C	*ENG	
007	Middle Speed:M	*ENG	
008	Middle Speed:Y	*ENG	
009	Low Speed:Bk	*ENG	
010	Low Speed:C	*ENG	
011	Low Speed:M	*ENG	
012	Low Speed:Y	*ENG	

3641	[Charge AC Control: Display]		
	Standard: 260 mm/sec		
Displays the charge AC voltage adjusted with the process control for each color.			
001	Standard Speed:Bk	*ENG	[0 to 3 / 1.75 / 0.01 kV/step]
002	Standard Speed:C	*ENG	
003	Standard Speed:M	*ENG	
004	Standard Speed:Y	*ENG	

3651	[LD Power Control: Display]		
	Standard: 260 mm/sec, Middle: 182 mm/sec, Low: 85 mm/sec		
Displays the LD power adjusted for each environment.			

001	Standard Speed:Bk	*ENG	[0 to 200 / 100 / 1 %/step]
002	Standard Speed:C	*ENG	
003	Standard Speed:M	*ENG	
004	Standard Speed:Y	*ENG	
005	Middle Speed:Bk	*ENG	
006	Middle Speed:C	*ENG	
007	Middle Speed:M	*ENG	
008	Middle Speed:Y	*ENG	
009	Low Speed:Bk	*ENG	
010	Low Speed:C	*ENG	
011	Low Speed:M	*ENG	
012	Low Speed:Y	*ENG	

3902	[Manual New Unit Set]		
	Turns the new unit detection flag for each PM unit on or off.		
001	Development Unit: Bk	*ENG	[0 or 1 / 0 / -] 0: OFF, 1: ON
002	Development Unit: C	*ENG	
003	Development Unit: M	*ENG	
004	Development Unit: Y	*ENG	
009	PCU: Bk	*ENG	[0 or 1 / 0 / -] 0: OFF, 1: ON
010	PCU: C	*ENG	
011	PCU: M	*ENG	
012	PCU: Y	*ENG	

013	Image Transfer Unit	*ENG	[0 or 1 / 0 / -] 0: OFF, 1: ON Do not use 3902-013 if you only change the cleaning unit. 3902-015: This is for the image transfer belt cleaning unit.
014	Fusing Unit	*ENG	
015	Fusing Roller	*ENG	
016	Fusing Belt	*ENG	
017	Image Transfer Cleaning Unit	*ENG	
018	Paper Transfer Unit	*ENG	[0 or 1 / 0 / -] 0: OFF, 1: ON
020	Image Transfer Toner Collection Bottle	*ENG	
206	ADF Pickup Roller	*ENG	[0 or 1 / 0 / -] 0: OFF, 1: ON
207	ADF Feed Roller	*ENG	
208	ADF Friction Pad	*ENG	

System SP4-xxx

SP4-XXX (Scanner)

4008	[Sub Scan Mag. Adjustment]		
	Adjusts the sub-scan magnification by changing the scanner motor speed.		
-		*ENG	[-1.0 to 1.0 / 0 / 0.1%/step] FA
4010	[L-Edge Regist Adjustment]		
	Adjusts the leading edge registration by changing the scanning start timing in the sub-scan direction.		
-		*ENG	[-2.0 to 2.0 / 0 / 0.1 mm/step] FA
4011	[Main Scan Reg]		
	Adjusts the side-to-side registration by changing the scanning start timing in the main scan direction.		
-		*ENG	[-2.5 to 2.5 / 0 / 0.1 mm/step] FA
4012	[Set Scale Mask]		
	Sets the blank margin at each side for erasing the original shadow caused by the gap between the original and the scale.		
	001	Book: Sub Leading Edge	*ENG [0 to 3.0 / 0 / 0.1 mm/step] FA
	002	Book: Sub Trailing Edge	
	003	Book: Main Leading Edge	
004	Book: Main Trailing Edge		
4013	[Scanner Free Run]		
	Performs the scanner free run with the exposure lamp on or off in the following mode. Full color mode / Full Size / A4 or LT		

001	Lamp: OFF	*ENG	OFF or ON
002	Lamp: ON		

4020	[DF Dust Check]		
001	Dust Detect: ON/OFF	*ENG	Turns the ADF scan glass dust check on/ off. [0 or 1 / 0 / 1 /step] 0: OFF, 1: ON
002	Dust Detect: Level	*ENG	Selects the detect level. [0 to 8 / 4 / 1 /step] 0: lowest detection level 8: highest detection level
003	Dust Reject: Level	*ENG	Selects the level of the sub scan line correction when using the ARDF. [0 to 4 / 0 / 1 /step] 0: Off 1: Weakest 2: Weak 3: Strong 4: Strongest

4400	[Org Edge Mask]	*ENG	
	Set the Mask for Original. These SPs set the area to be masked during platen (book) mode scanning.		
	001	Book: Sub Leading Edge	[0 to 3.0 / 0 / 0.1 mm/step]
	002	Book: Sub Trailing Edge	
	003	Book: Main Leading Edge	
	004	Book: Main Trailing Edge	
	005	ADF: Sub Leading Edge	
	007	ADF: Main Leading Edge	
	008	ADF: Main Trailing Edge	

4417	[IPU Test Pattern]	
	Selects the IPU test pattern.	
001	Test Pattern	[0 to 24 / 0 / 1/step]
	0: Scanned image 1: Gradation main scan A 2: Gradation main scan B 3: Gradation main scan C 4: Gradation main scan D 5: Gradation sub scan (1) 6: Grid pattern 7: Slant grid pattern 8: Gradation RGBCMYK 9: UCR pattern 10: Color patch 16 (1) 11: Color patch 16 (2) 12: Color patch 64	13: Grid pattern CMYK 14: Color patch CMYK 15: Gray pattern (1) 16: Gray pattern (2) 17: Gray Pattern (3) 18: Shading pattern 19: Thin line pattern 20: Scanned + Grid pattern 21: Scanned + Gray scale 22: Scanned + Color patch 23: Scanned + Slant Grid C 24: Scanned + Slant Grid D

4429	[Select Copy Data Security]		
001	Copying	*ENG	[0 to 3 / 3 / 1 /step]
002	Scanning		
003	Fax Operation		

4450	[Scan Image Path Selection]	
001	Black Subtraction ON/OFF	[0 or 1 / 1 / -] 0: OFF, 1: ON
	Uses or does not use the black reduction image path.	
002	SH ON/OFF	[0 or 1 / 0 / 1 /step] 0: ON, 1: OFF
	Uses or does not use the shading image path.	

4460	[Digital AE]	
	Adjust the background level.	

001	Low Limit Value	*ENG	[0 to 1023 / 364 / 1 /step]
002	Background Level		[512 to 1535 / 932 / 1 /step]

4501	[ACC Target Density]		
	Selects the ACC result.		
001	Copy: K: Text	*ENG	[0 to 10 / 5 / 1 /step] 10: Darkest density
002	Copy: C: Text	*ENG	
003	Copy: M: Text	*ENG	
004	Copy: Y: Text	*ENG	
005	Copy: K: Photo	*ENG	
006	Copy: C: Photo	*ENG	
007	Copy: M: Photo	*ENG	
008	Copy: Y: Photo	*ENG	

4505	[ACC Cor:Bright]		
	Adjusts the offset correction for light areas of the ACC pattern.		
001	Text:K	*ENG	[-128 to 127 / 0 / 1 /step]
002	Text:C	*ENG	
003	Text:M	*ENG	
004	Text:Y	*ENG	
005	Photo:K	*ENG	[-128 to 127 / 0 / 1 /step]
006	Photo:C	*ENG	
007	Photo:M	*ENG	
008	Photo:Y	*ENG	

4506	[ACC Cor:Dark]		
	Adjusts the offset correction for dark areas of the ACC pattern.		

001	Text:K	*ENG	[-128 to 127 / 0 / 1 /step]
002	Text:C	*ENG	
003	Text:M	*ENG	
004	Text:Y	*ENG	
005	Photo:K	*ENG	[-128 to 127 / 0 / 1 /step]
006	Photo:C	*ENG	
007	Photo:M	*ENG	
008	Photo:Y	*ENG	

4540	[Print Coverage]		
	This SP corrects the printer coverage of 12 hues (RY, YR, YG, etc. x 4 Colors [R, G, B, Option]) for a total of 48 parameters.		
001-004	RY Phase: Option/R/G/B	*ENG	Specifies the printer vector correction value. [0 to 255 / 0 / 1 /step]
005-008	YR Phase: Option/R/G/B	*ENG	
009-012	YG Phase: Option/R/G/B	*ENG	
013-016	GY Phase: Option/R/G/B	*ENG	
017-020	GC Phase: Option/R/G/B	*ENG	
021-024	CG Phase: Option/R/G/B	*ENG	
025-028	CB Phase: Option/R/G/B	*ENG	
029-032	BC Phase: Option/R/G/B	*ENG	
033-036	BM Phase: Option/R/G/B	*ENG	
037-040	MB Phase: Option/R/G/B	*ENG	
041-044	MR Phase: Option/R/G/B	*ENG	
045-048	RM Phase: Option/R/G/B	*ENG	
049-052	WHITE: Option/R/G/B	*ENG	
053-056	BLACK: Option/R/G/B	*ENG	

4550	[Scanner Apli.:Text/Print] DFU		
4551	[Scanner Apli.: Text] DFU		
4552	[Scanner Apli.:Txt Dropout] DFU		
4553	[Scanner Apli.:Text/Photo] DFU		
4554	[Scanner Apli.: Photo] DFU		
4565	[Scanner Apli.: GrayScale] DFU		
4570	[Scan Apli.: Color: Text/Photo] DFU		
4571	[Scan Apli.: Color: Glossy Photo] DFU		
4572	[Scan Apli.: AutoColor] DFU		
4580	[FAX Apli.: Text/Chart] DFU		
4581	[FAX Apli.: Text] DFU		
4582	[FAX Apli.: Text/Photo] DFU		
4583	[FAX Apli.: Photo] DFU		
4584	[FAX Apli.: Original 1] DFU		
4585	[FAX Apli.: Original 2] DFU		
4600	[SBU Version Display]		
001	SBU ID	-	Displays the ID of the SBU.
002	GASBU-N ID	-	Displays the ID of the GASBU.

003	VSP5100 ID	-	Displays the ID of the VSP5100.
4609	[Gray Balance Set: R]		
001	Book Read	-	[-512 to 511 / -80 / 1 digit/step]
002	DF Read	-	[-512 to 511 / -80 / 1 digit/step]
4610	[Gray Balance Set: G]		
001	Book Read	-	[-512 to 511 / -85 / 1 digit/step]
002	DF Read		
4611	[Gray Balance Set: B]		
001	Book Read	-	[-512 to 511 / -80 / 1 digit/step]
002	DF Read		
4645	[Scan Adjust Error]		
001	White level	-	[0 to 65535 / 0 / 1 digit/step]
002	Black level	-	
4647	[Scanner Hard Error]		
	Displays the result of the SBU connection check.		
001	Power-ON	-	[0 to 35535 / 0 / 1 digit /step] 0: OK, Other: SBU connection check failure If the SBU connection check fails, SC144 occurs.
4688	[DF Density Adjustment]		
	Adjusts the white shading parameter when scanning an image with the ARDF. Adjusts the density level if the ID of outputs made in the DF and Platen mode is different.		
	-	*ENG	[50 to 150 / 100 / 1%/ step]
4807	[SBU Test Pattern Change]		

	-	-	[0 to 250 / 0 / 1 /step] 1: Grid pattern 2: Gradation main scan 3: Gradation sub scan 4 to 250: Default (Scanning Image)
--	---	---	--

4902	[Disp ACC Data]		
	This SP outputs the final data read at the end of ACC execution. A zero is returned if there was an error reading the data. [0 to 255 / 0 / 1 /step]		
001	R DATA1	*ENG	Photo C Patch Level 1 (8-bit)
002	G DATA1	*ENG	Photo M Patch Level 1 (8-bit)
003	B DATA1	*ENG	Photo Y Patch Level 1 (8-bit)
004	R DATA2	*ENG	Photo C Patch Level 17 (8-bit)
005	G DATA2	*ENG	Photo M Patch Level 17(8-bit)
006	B DATA2	*ENG	Photo Y Patch Level 17 (8-bit)

4905	[Select Gradation Level] DFU		
	Changes the parameters for error diffusion.		
	-	*ENG G	[0 to 255 / 0 / 1 /step]

4918	[Manual Gamma Adj]		
	Adjusts the offset data of the printer gamma for yellow in Photo mode. See "Printer Gamma Correction" in the Replacement and Adjustment for how to use.		
009	-	-	Enter the manual gamma adjustment screen (-001 to 008). For details, see the "Printer Gamma Correction" in the section "Replace and Adjustment".

4938	[ACS Edge Mask] DFU		
------	----------------------------	--	--

001	Copy: Sub LEdge	[0 to 31/10/1 mm]
002	Copy: Sub TEdge	
003	Copy: Main LEdge	
004	Copy: Main TEdge	
005	Scan: Sub LEdge	[0 to 31/15/1 mm]
006	Scan: Sub TEdge	
007	Scan: Main LEdge	
008	Scan: Main TEdge	

4939	[ACS Color Range] DFU
	[-2 to 2/0/1 Step]

4948	[ACC Execute Time: Present] DFU
	Displays the date and time of the most recent ACC execution.
001	yy/mm/dd
002	hh/mm/ss

4949	[ACC Execute Time: Previous] DFU
	Displays the date and time of the ACC execution before the most recent ACC execution..
001	yy/mm/dd
002	hh/mm/ss

4991	[IPU Image Path Selection]
	Selects the image path. Enter the number to be selected using the 10-key pad.

	RGB Frame Memory	*ENG	[0 to 11 / 2 / 1 /step]
	0: Scanner input RGB images 1: Scanner I/F RGB images 2: RGB images done by Shading correction (Shading ON, Black offset ON) 3: Shading data 4 to 11: Not used		

4993	[High Light Correction]		
001	Sensitivity Selection	*ENG	Selects the Highlight correction level. [0 to 9 / 4 / 1 /step] 0: weakest sensitivity 9: strongest sensitivity
002	Range Selection	*ENG	Selects the range level of Highlight correction. [0 to 9 / 4 / 1 /step] 0: weakest skew correction, 9: strongest skew correction

4994	[Text/Photo Detection Level Adj.]		
	Selects the definition level between Text and Photo for high compression PDF.		
	High Compression PDF	*ENG	[0 to 2 / 1 / 1 /step] 0: Text priority 1: Normal 2: Photo priority

4996	[White Paper Detect Level]		
	Adjusts the white paper detect level for fax.		
	-	*ENG	[0 to 6 / 3 / 1 /step]

System SP5-xxx: 1

SP5-XXX (Mode)

5009	[Add Display Language]		
	<p>Adds language available in user choice. (Only the languages registered in the machine). Refer to the displayed language list to set in the way showed below.</p> <p>List Number and Assigned Bit Switches</p> <ul style="list-style-type: none"> No.1 to 8: BIT0 to 7 (SP5009-201) No.9 to 16: BIT0 to 7 (SP5009-202) No.17 to 24: BIT0 to 7 (SP5009-203) No.25 to 32: BIT0 to 7 (SP5009-204) <p>Example: To add American(No.3 in the list) or Czech (No.15)</p> <ul style="list-style-type: none"> Turn Bit 2 of "SP5009-201" 0 to 1 for American. Turn Bit 6 of "SP5009-202" 0 to 1 for Czech. After setting, turn the main power switch off and on to make the setting valid. 		
201	1-8	*CTL	[1 to 255 /0/ 1/step]
	<p>No.1 (Bit0): Japanese No.2 (Bit1): Not used No.3 (Bit2): English-US No.4 (Bit3): French No.5 (Bit4): German No.6 (Bit5): Italian No.7 (Bit6): Spanish No.8 (Bit7): Dutch</p>		
202	9-16	*CTL	[1 to 255 /0/1/step]

	No.9 (Bit0): Norwegian No.10 (Bit1): Danish No.11 (Bit2): Swedish No.12 (Bit3): Polish No.13 (Bit4): Portuguese No.14 (Bit5): Hungarian No.15 (Bit6): Czech No.16 (Bit7): Finnish		
203	17-24	*CTL	[1 to 255 /0 /1/step]
	No.17 (Bit0): Not used No.18 (Bit1): Traditional Chinese No.19 (Bit2): Not used No.20 (Bit3): Russian No.21 (Bit4): Not used No.22 (Bit5): Not used No.23 (Bit6): Greek No.24 (Bit7): Not used		
204	25-32	*CTL	[1 to 255 /0/ 1/step]
	No.25 (Bit0): Catalan No.26 (Bit1): Turkish No.27 (Bit2): Brazilian Portuguese No.28 (Bit3) to 32 (Bit7): Not used		
5024	[mm/inch Display Selection]		
	Display units (mm or inch) for custom paper sizes.		
001	-	*CTL	[0 or 1 / 0 / -] 0: mm (Europe/Asia) 1: inch (USA)
5045	[Accounting Counter]		
	Selects the counting method.		

001	Counter Method	*CTL	[0 or 1 / 0 / -] 0: Developments 1: Prints
-----	----------------	------	--

5051	[Toner Refill Detection Display]		
	Enables or disables the toner refill detection display.		
001	-	*CTL	[0 or 1 / 0 / -] Alphanumeric 0: ON 1: OFF

5055	[Display IP Address]		
	Display or does not display the IP address on the operation panel.		
001	-	*CTL	[0 or 1 / 0 / -] 0: OFF 1: ON

5061	[Toner Remaining Icon Display Change]		
	Display or does not display the remaining toner display icon on the LCD.		
001	-	*CTL	[0 or 1 / 0 / -] 0: Not display, 1: Display

5062	[Parts Replacement Alert Display]		
	Display or does not display the PM part yield on the LCD.		
001	PCU: Bk	*CTL	[0 or 1 / 0 / -] 0: No display, 1: Display
002	PCU: M	*CTL	
003	PCU: C	*CTL	
004	PCU: Y	*CTL	

005	Development Unit: Bk	*CTL	[0 or 1 / 0 / -] 0: No display, 1: Display
006	Development Unit: M	*CTL	
007	Development Unit: C	*CTL	
008	Development Unit: Y	*CTL	
013	Image Transfer Belt	*CTL	[0 or 1 / 0 / -] 0: No display, 1: Display
014	Image Transfer Cleaning Unit	*CTL	
015	Fusing Unit	*CTL	
016	PTR Unit	*CTL	
017	Toner Collection Bottle	*CTL	
018	Fusing Roller	*CTL	
019	Fusing Belt	*CTL	

5066	[PM Parts Display] Display or does not display the "PM parts" button on the LCD.		
001	-	*CTL	[0 or 1 / 0 / -] 0: No display, 1: Display

5067	[Parts Replacement Operation Type] Selects the service maintenance or user maintenance for each PM part. If the user service is selected, PM alert is displayed on the LCD.		
001	PCU:Bk	*CTL	[0: Service] or [1: User]
002	PCU:M	*CTL	
003	PCU:C	*CTL	
004	PCU:Y	*CTL	

005	Dev Unit:Bk	*CTL	[0: Service] or [1: User]
006	Dev Unit:M	*CTL	
007	Dev Unit:C	*CTL	
008	Dev Unit:Y	*CTL	
013	Image Transfer Belt	*CTL	[0: Service] or [1: User]
014	Image Transfer Cleaning	*CTL	[0: Service] or [1: User]
015	Fusing Unit	*CTL	[0: Service] or [1: User]
016	PTR Unit	*CTL	[0: Service] or [1: User]
017	Toner Collection Bottle	*CTL	[0: Service] or [1: User]
018	Fusing Roller	*CTL	[0: Service] or [1: User]
019	Fusing Belt	*CTL	[0: Service] or [1: User]

5071	[Set Bypass Paper Size Display]		
	Display or does not display the by-pass paper size on the LCD.		
001	-	*CTL	[0 or 1 / 0 / -] 0: No display, 1: Display

5073	[Supply Part Replacement Operation Type]		
	This SP makes it possible for users to replace the bottle.		
001	Waste Toner Bottle	*CTL	[0 or 1 / 0 / -] 0: Service, 1: User

5074	[Home Key Customization]		
	Sets applications that appear on the operation panel when the [Home] key is pressed.		
002	Login Setting	*CTL	[0 to 0xFF / 00000000 / 1/step] Sets login operation mode for panel display.

091	Function Setting	*CTL	[0 to 2 / 0 / 1/step] 0: Function disable 1: SDK application 2: Legacy application (reserved)
092	Product ID	*CTL	[0 to 0xFFFF FFFF / 0 / 1/step] Sets the application product ID.
093	Application Screen ID	*CTL	[0 to 255 / 0 / 1/step] Sets the display category of the application that is specified in the SP5075-001 Setting for future function enhancement.

5

5076	[Copy: LT/LG Mixed Size Setting]		
	This machine supports copying and scanning of mixed LTR/LG size originals. However, this feature is not enabled by default. This SP switches this feature on/off for copying. Note: <ul style="list-style-type: none"> The paper feed unit option is required to use this feature with the scanner. The scanner service mode must be switched on with SP1040 [Scanner: LT/LG Mixed Sizes Setting] because its default setting is "0" (OFF). 		
	[0 to 1/0/1] 0: OFF 1: ON		

5081	[Services SP Entry Code Setting] DFU		
	-	*CTL	[000000 to 999999 / - / -/step]

5083	[LED Light Switch Setting]		
	Sets LCD 4 (4LCD: Alarm LCD) to blink and confirm the toner near end status.		
	Toner Near End	*CTL	[0 or 1 / 0 / 1/step] 0: OFF 1: ON

5113	[Optional Counter Type]		
------	--------------------------------	--	--

001	Default Optional Counter Type	*CTL	This program specifies the counter type. 0: None , 1: Key card (RK 3, 4) 2: Key card (down), 3: Prepaid card 4: Coin rack, 5: MF key card 8: Key counter + Vendor 9: Bar-code Printer
002	External Optional Counter Type	*CTL	This program specifies the external counter type. 0: None 1: Expansion Device 1 2: Expansion Device 2 3: Expansion Device 3

5114	[Optional Counter I/F]		
001	MF Key Card Extension	*CTL	[0: Not installed / 1: Installed (scanning accounting)]

5118	[Disable Copying]	*CTL	[0: Not disabled / 1: Disabled]
001	This program disables copying.		

5120	[Mode Clear Opt. Counter Removal]	*CTL	[0: Yes (removed) / 1: Standby (installed but not used)/ 2: No (not removed)]
	This program updates the information on the optional counter. When you install or remove an optional counter, check the settings.		

5121	[Counter Up Timing]	*CTL	[0: Feed / 1: Exit]
001	This SP specifies when the counter goes up. The settings refer to "paper feed" and "paper exit" respectively.		

5127	[APS Mode]	*CTL	[0: Not disabled / 1: Disabled]
001	This program disables the APS.		

5128	[Code Mode With Key/Card Option]	*CTL	[0: Not disabled/ 1: Disabled]
001	This program disables the code mode with key/card option.		

5131	[Paper Size Type Selection]		
001	1.NA 2.EU ASIA	*EN G	[0 to 2 / 1: NA, 2: EU / 1] 0: Japan, 1: NA, 2: EU
	Selects the paper size type (for originals and paper). After changing the value, turn the main power switch off and on.		

5150	[Bypass Length Setting]		
001	-	*CTL	[0: OFF/ 1: ON]
	Determines whether the transfer sheet from the by-pass tray is used or not. Normally the paper length for sub scanning paper from the by-pass tray is limited to 600 mm, but this can be extended with this SP to 1260 mm.		

5162	[App. Switch Method]	*CTL	[0: Soft Key Set/ 1: Hard Key Set]
001	This program specifies the switch that selects an application program.		

5	[Z-Fold Position]		
1			
6			
5			
001	A3T	*CTL	[(NA:2.5, other:2.0) to (NA:25.4, other:25.0) / NA:2.5, Other:2.0 / 1 mm/step]
002	B4T	*CTL	[(NA:2.5, other:2.0) to (NA:40.6, other:40.0) / NA:2.5, Other:2.0 / 1 mm/step]
003	A4T	*CTL	[(NA:2.5, other:2.0) to (NA:10.2, other:10.0) / NA:2.5, Other:2.0 / 1 mm/step]
004	DLTT	*CTL	[(NA:2.5, other:2.0) to (NA:20.3, other:20.0) / NA:2.5, Other:2.0 / 1 mm/step]

005	LGT	*CTL	[[NA:2.5, other:2.0) to (NA:35.6, other:35.0) / NA:2.5, Other:2.0 / 1 mm/step]
006	LTT	*CTL	[[NA:2.5, other:2.0) to (NA:2.5, other:2.0) / NA:2.5, Other:2.0 / 1 mm/step]
007	12x18	*CTL	[[NA:2.5, other:2.0) to (NA:5.1, other:5.0) / NA:2.5, Other:2.0 / 1 mm/step]
008	Other	*CTL	[[NA:2.5, other:2.0) to (NA:2.5, other:2.0) / NA:2.5, Other:2.0 / 1 mm/step]

5167	[Fax Printing Mode at Optional Counter Off]		
	Enables or disables the automatic print out without an accounting device. This SP is used when the receiving fax is accounted by an external accounting device.		
001	Fax Printing Mode at Optional Counter Off	*CTL	[0 or 1 / 0 / -] 0: Automatic printing 1: No automatic printing

5169	[CE Login]		
	If you will change the printer bit switches, you must 'log in' to service mode with this SP before you go into the printer SP mode.		
001	-	*CTL	[0 or 1 / 0 / -] 0: Disabled 1: Enabled

5186	[RK4]		
	Enables or disables the prevention for RK4 (accounting device) disconnection. If the RK4 is disconnected for 10 seconds when this SP is set to "1 (Enable)", the machine automatically jams a sheet of paper and stops.		
001	-	*EN G	[0 or 1 / 0 / 1 /step] 0: Disable 1: Enable

5188	[Copy Nv Version]		
	Displays the version number of the NVRAM on the controller board.		
001	-	-	-

5191	[Mode Set] DFU		
001	-	*CTL	[0 or 1 / 1 / -] 0: Off, 1: On
	Enables or disables the STR (Suspend to RAM) mode.		

5195	[Limitless SW] DFU		
001	-	*CTL	[0 or 1 / 1 / -] 0: Productivity priority 1: Tray priority
	<p>Selects the paper feed mode.</p> <p>Productivity priority: This changes the feeding tray as soon as the machine detects the priority tray even the paper still remains in the feeding tray.</p> <p>Tray priority: This changes the feeding tray after the paper in the tray where the machine has been feeding paper has been run out of.</p> <p>This SP is activated only when a customer selects the "Auto Paper Selst".</p>		

5199	[Paper Exit After Staple End.]		
001	-	*CTL	[0 or 1 / 0 / -] 0: OFF, 1: ON
	<p>Enables or disables the paper feeding out from the finisher without stapling.</p> <ul style="list-style-type: none"> If this setting is "1: ON", paper is fed out without stapling at the maximum number of the finisher stapling when the machine gets a multiple printing job (over maximum number). If this setting is "0: OFF", paper is fed out with stapling at the maximum number of the finisher stapling when the machine gets a multiple printing job (over maximum number). 		

5212	[Page Numbering]	*CTL	
	This program adjusts the position of the second side page numbers. A "-" value" moves the page number positions to the left edge. A "+" value" moves the page number positions to the right edge.		
003	Duplex Printout Right/Left Position		[-10 to 10 / 0 / 1 mm/step]
004	Duplex Printout High/Low Position		[-10 to 10 / 0 / 1 mm/step]

5227	[Page Numbering]	*CTL	
	This program adjusts the position of the second side page numbers. A "-" value" moves the page number positions to the left edge. A "+" value" moves the page number positions to the right edge.		
003	Allow Page No. Entry		[2 to 9 / 9 / 1/step]
004	Zero Surplus Setting		[0 or 1 / 0 / 1/step]

	[Set Time]		
5302	Adjusts the RTC (real time clock) time setting for the local time zone. Examples: For Japan (+9 GMT), enter 540 (9 hours x 60 min.) DOM: +540 (Tokyo) NA: -300 (New York) EU: + 60 (Paris) CH: +480 (Peking) TW: +480 (Taipei) AS: +480 (Hong Kong) KO: +540 (Korea)		
002	Time Difference	*CTL#	[-1440 to 1440 / Area / 1 min./step]

5305	[Auto Off Select] DFU Auto Off Time Set		
	[0 to 1/ 0 /1 Step]		

5307	[Daylight Saving Time]		
001	Setting	-	<p>[0 to 1 / NA, EU, ASIA / 1 /step]</p> <p>0: Disabled</p> <p>1: Enabled</p> <p>NA and EUR: 1, ASIA: 0</p>
<p>Enables or disables the summer time mode.</p> <p>Note</p> <ul style="list-style-type: none"> Make sure that both SP5-307-3 and -4 are correctly set. Otherwise, this SP is not activated even if this SP is set to "1". 			
003	Rule Set (Start)	-	<p>Specifies the start setting for the summer time mode.</p> <p>There are 8 digits in this SP. For months 1 to 9, the "0" cannot be input in the first digit, so the eight-digit setting for -2 or -3 becomes a seven-digit setting.</p> <p>1st and 2nd digits: The month. [1 to 12]</p> <p>3rd digit: The week of the month. [1 to 5]</p> <p>4th digit: The day of the week. [0 to 6 = Sunday to Saturday]</p> <p>5th and 6th digits: The hour. [00 to 23]</p> <p>7th digit: The length of the advanced time. [0 to 9 / 1 hour /step]</p> <p>8th digit: The length of the advanced time. [0 to 5 / 10 minutes /step]</p> <p>For example: 3500010 (EU default)</p> <p>The timer is advanced by 1 hour at am 0:00 on the 5th Sunday in March</p> <ul style="list-style-type: none"> The digits are counted from the left. Make sure that SP5-307-1 is set to "1".

	Rule Set (End)	-	-
004	<p>Specifies the end setting for the summer time mode.</p> <p>There are 8 digits in this SP.</p> <p>1st and 2nd digits: The month. [1 to 12]</p> <p>3rd digit: The week of the month. [0 to 5]</p> <p>4th digit: The day of the week. [0 to 7 = Sunday to Saturday]</p> <p>5th and 6th digits: The hour. [00 to 23]</p> <p>The 7th and 8 digits must be set to "00".</p> <ul style="list-style-type: none"> • The digits are counted from the left. • Make sure that SP5-307-1 is set to "1". 		

5401	[Access Control] DFU		
	When installing the SDK application, SAS (VAS) adjusts the following settings.		
103	Default Document ACL	*CTL	-
	<p>Whenever a new login user is added to the address book in external certification mode (for Windows, LDAP, RDH), the default document ACL is updated according to this SP setting.</p> <p>[0 to 3 / 0 / 1]</p> <p>0: View</p> <p>1: Edit</p> <p>2: Edit/Delete</p> <p>3: Full control</p> <p>Note: This SP setting is ignored on a machine that is not using document server.</p>		
104	Authentication Time	*CTL	[0 to 255 / 0 / 1 second]
	<p>Specifies the time for the authentication timeout.</p> <p>0 = 60 seconds, 1 to 255 = displayed time (seconds)</p>		
162	Extend Certification Detail	*CTL	<p>Selects the log out type for the extend authentication device.</p> <p>Bit 0: Log-out without an IC card</p> <p>0: Not allowed (default)</p> <p>1: Allowed</p>

200	SDK1 Unique ID	*CTL	"SDK" is the "Software Development Kit". This data can be converted from SAS (VAS) when installed or uninstalled.
201	SDK1 Certification Method	*CTL	
210	SDK2 Unique ID	*CTL	
211	SDK2 Certification Method	*CTL	
220	SDK3 Unique ID	*CTL	
221	SDK3 Certification Method	*CTL	
230	SDK certification device	*CTL	-
	<ul style="list-style-type: none"> • Bit 0: SDK authentication 0: Off (Default), 1: On (SDK authentication enabled) Selects the SDK authentication setting. • Bit 2: Administrator log in setting 0: Off (Default), 1: On 		
240	Detail Option	*CTL	-
	<p>Enalbes or disables the log out confirmation option.</p> <ul style="list-style-type: none"> • Bit 0: Log out confirmation option 0: Enable (default), 1: Disable Selects the automatic log out time. • Bit 1 and 2: Automatic log out timer reduction 00: 60 seconds (default), 01: 10 seconds, 10: 20 seconds, 11: 30 seconds 		
5402	[Access Control]		

101	SDKJ1 Limit Setting	*CTL	<p>[0 to 0xFF / 00000000 / 1/step]</p> <p>bit0: SDKJ Authentication</p> <p>-0: Panel Type</p> <p>-1: Remote Type</p> <p>bit1: Using user code setup</p> <p>-0: OFF, 1: ON</p> <p>bit2: Using key-counter setup</p> <p>-0: OFF, 1: ON</p> <p>bit3: Using external billing device setup</p> <p>-0: OFF, 1: ON</p> <p>bit4: Using extended external billing device setup</p> <p>-0: OFF, 1: ON</p> <p>bit5 to 6: Not used</p> <p>bit7: Using extended function J limit users</p> <p>-0: OFF, 1: ON</p>
102	SDKJ2 Limit Setting	*CTL	
103	SDKJ3 Limit Setting	*CTL	
104	SDKJ4 Limit Setting	*CTL	
105	SDKJ5 Limit Setting	*CTL	
106	SDKJ6 Limit Setting	*CTL	
107	SDKJ7 Limit Setting	*CTL	
108	SDKJ8 Limit Setting	*CTL	
109	SDKJ9 Limit Setting	*CTL	
110	SDKJ10 Limit Setting	*CTL	
111	SDKJ11 Limit Setting	*CTL	
112	SDKJ12 Limit Setting	*CTL	
113	SDKJ13 Limit Setting	*CTL	
114	SDKJ14 Limit Setting	*CTL	
115	SDKJ15 Limit Setting	*CTL	
116	SDKJ16 Limit Setting	*CTL	

117	SDKJ17 Limit Setting	*CTL	[0 to 0xFF / 00000000 / 1/step] bit0: SDKJ Authentication -0: Panel Type -1: Remote Type bit1: Using user code setup -0: OFF, 1: ON bit2: Using key-counter setup -0: OFF, 1: ON bit3: Using external billing device setup -0: OFF, 1: ON bit4: Using extended external billing device setup -0: OFF, 1: ON bit5 to 6: Not used bit7: Using extended function J limit users -0: OFF, 1: ON
118	SDKJ18 Limit Setting	*CTL	
119	SDKJ19 Limit Setting	*CTL	
120	SDKJ20 Limit Setting	*CTL	
121	SDKJ21 Limit Setting	*CTL	
122	SDKJ22 Limit Setting	*CTL	
123	SDKJ23 Limit Setting	*CTL	
124	SDKJ24 Limit Setting	*CTL	
125	SDKJ25 Limit Setting	*CTL	
126	SDKJ26 Limit Setting	*CTL	
127	SDKJ27 Limit Setting	*CTL	
128	SDKJ28 Limit Setting	*CTL	
129	SDKJ29 Limit Setting	*CTL	
130	SDKJ30 Limit Setting	*CTL	
141	SDKJ1 ProductID	*CTL	[0 to 0xFFFFFFFF / 0 / 1/step]
142	SDKJ2 ProductID	*CTL	[0 to 0xFFFFFFFF / 0 / 1/step]
143	SDKJ3 ProductID	*CTL	[0 to 0xFFFFFFFF / 0 / 1/step]
144	SDKJ4 ProductID	*CTL	[0 to 0xFFFFFFFF / 0 / 1/step]
145	SDKJ5 ProductID	*CTL	[0 to 0xFFFFFFFF / 0 / 1/step]
146	SDKJ6 ProductID	*CTL	[0 to 0xFFFFFFFF / 0 / 1/step]
147	SDKJ7 ProductID	*CTL	[0 to 0xFFFFFFFF / 0 / 1/step]
148	SDKJ8 ProductID	*CTL	[0 to 0xFFFFFFFF / 0 / 1/step]
149	SDKJ9 ProductID	*CTL	[0 to 0xFFFFFFFF / 0 / 1/step]
150	SDKJ10 ProductID	*CTL	[0 to 0xFFFFFFFF / 0 / 1/step]
151	SDKJ11 ProductID	*CTL	[0 to 0xFFFFFFFF / 0 / 1/step]
152	SDKJ12 ProductID	*CTL	[0 to 0xFFFFFFFF / 0 / 1/step]

153	SDKJ13 ProductID	*CTL	[0 to 0xFFFFFFFF / 0 / 1/step]
154	SDKJ14 ProductID	*CTL	[0 to 0xFFFFFFFF / 0 / 1/step]
155	SDKJ15 ProductID	*CTL	[0 to 0xFFFFFFFF / 0 / 1/step]
156	SDKJ16 ProductID	*CTL	[0 to 0xFFFFFFFF / 0 / 1/step]
157	SDKJ17 ProductID	*CTL	[0 to 0xFFFFFFFF / 0 / 1/step]
158	SDKJ18 ProductID	*CTL	[0 to 0xFFFFFFFF / 0 / 1/step]
159	SDKJ19 ProductID	*CTL	[0 to 0xFFFFFFFF / 0 / 1/step]
160	SDKJ20 ProductID	*CTL	[0 to 0xFFFFFFFF / 0 / 1/step]
161	SDKJ21 ProductID	*CTL	[0 to 0xFFFFFFFF / 0 / 1/step]
162	SDKJ22 ProductID	*CTL	[0 to 0xFFFFFFFF / 0 / 1/step]
163	SDKJ23 ProductID	*CTL	[0 to 0xFFFFFFFF / 0 / 1/step]
164	SDKJ24 ProductID	*CTL	[0 to 0xFFFFFFFF / 0 / 1/step]
165	SDKJ25 ProductID	*CTL	[0 to 0xFFFFFFFF / 0 / 1/step]
166	SDKJ26 ProductID	*CTL	[0 to 0xFFFFFFFF / 0 / 1/step]
167	SDKJ27 ProductID	*CTL	[0 to 0xFFFFFFFF / 0 / 1/step]
168	SDKJ28 ProductID	*CTL	[0 to 0xFFFFFFFF / 0 / 1/step]
169	SDKJ29 ProductID	*CTL	[0 to 0xFFFFFFFF / 0 / 1/step]
170	SDKJ30 ProductID	*CTL	[0 to 0xFFFFFFFF / 0 / 1/step]

5404	[User Code Count Clear]		
001	-	*CTL	Clears all counters for users.

5411	[LDAP Certification]		
004	Easy Certification	*CTL	Determines whether easy LDAP certification is done. [0 to 1 / 1 / 1] 1: On, 0: Off

005	Password Null Not Permit	*CTL	This SP is referenced only when SP5411-4 is set to "1" (On). [0 to 1 / 1 / 1] 0: Password NULL not permitted. 1: Password NULL permitted.
006	Detail Option	*CTL	-

5412

[Krb-Certification]

Executes Kerberos certification according to certified encryption strength. Kerberos is a computer network authentication protocol which works on the basis of tickets to allow nodes communicating over a non-secure network to prove their identity to one another in a secure manner. Kerberos also refers to a suite of free software published by Massachusetts Institute of Technology (MIT) that implements the Kerberos protocol.

100

Encrypt Mode

C*

[- / 11111111 / 1/step]
0x01: AES256-CTS-HMAC-SHA1-96
0x02: AES128-CTS-HMAC-SHA1-96
0x04: DES3-CBC-SHA1
0x08: RC4-HMAC
0x10: DES-CBC-MD5
0xFF(0x1F): ALL

5413

[Lockout Setting]

001

Lockout On/Off

*CTL

Switches on/off the lock on the local address book account.
[0 to 1 / 0 / 1]
0: Off, 1: On

002

Lockout Threshold

*CTL

Sets a limit on the frequency of lockouts for account lockouts.
[1 to 10 / 5 / 1]

003	Cancellation On/Off	*CTL	<p>Determines whether the system waits the prescribed time for input of a correct user ID and password after an account lockout has occurred.</p> <p>[0 to 1 / 0 / 1]</p> <p>0: Off (no wait time, lockout not cancelled)</p> <p>1: On (system waits, cancels lockout if correct user ID and password are entered).</p>
004	Cancellation Time	*CTL	<p>Determines the length of time that the system waits for correct input of the user ID and password after a lockout has occurred. This setting is used only if SP5413-3 is set to "1" (on).</p> <p>[1 to 9999 / 60 / 1 min.]</p>

5414	[Access Mitigation]		
001	Mitigation On/Off	*CTL	<p>Switches on/off masking of continuously used IDs and passwords that are identical.</p> <p>[0 to 1 / 0 / 1]</p> <p>0: Off</p> <p>1: On</p>
002	Mitigation Time	*CTL	<p>Sets the length of time for excluding continuous access for identical user IDs and passwords.</p> <p>[0 to 60 / 15 / 1 min.]</p>

5415	[Password Attack]		
001	Permissible Number	*CTL	<p>Sets the number of attempts to attack the system with random passwords to gain illegal access to the system.</p> <p>[0 to 100 / 30 / 1 attempt]</p>
002	Detect Time	*CTL	<p>Sets the time limit to stop a password attack once such an attack has been detected.</p> <p>[1 to 10 / 5 / 1 sec.]</p>

5416	[Access Information]		
-------------	-----------------------------	--	--

001	Access User Max Num	*CTL	Limits the number of users used by the access exclusion and password attack detection functions. [50 to 200 / 200 / 1 users]
002	Access Password Max Num	*CTL	Limits the number of passwords used by the access exclusion and password attack detection functions. [50 to 200 / 200 / 1 passwords]
003	Monitor Interval	*CTL	Sets the processing time interval for referencing user ID and password information. [1 to 10 / 3 / 1 sec.]

5417	[Access Attack]		
001	Access Permissible Number	*CTL	Sets a limit on access attempts when an excessive number of attempts are detected for MFP features. [0 to 500 / 100 / 1]
002	Attack Detect Time	*CTL	Sets the length of time for monitoring the frequency of access to MFP features. [10 to 30 / 10 / 1 sec.]
003	Productivity Fall Wait	*CTL	Sets the wait time to slow down the speed of certification when an excessive number of access attempts have been detected. [0 to 9 / 3 / 1 sec.]
004	Attack Max Num	*CTL	Sets a limit on the number of requests received for certification in order to slow down the certification speed when an excessive number of access attempts have been detected. [50 to 200 / 200 / 1 attempt]

5420	[User Authentication]		
	<p>These settings should be done with the System Administrator.</p> <p>Note: These functions are enabled only after the user access feature has been enabled.</p>		

001	Copy	*CTL	Determines whether certification is required before a user can use the copy applications. [0 to 1 / 0 / 1] 0: On, 1: Off
002	Color Security Setting	*CTL	-
	<p>Enables or disables the color copy limitation for each copy mode when the user authentication is "ON".</p> <p>0: Enable (default), 1: Disable</p> <p>Bit0: B/W mode Bit1: Mono color mode Bit2: Two colors mode Bit3: Full color mode Bit4: Automatic color mode Bit5 to 7: Reserved</p>		
011	DocumentServer	*CTL	Determines whether certification is required before a user can use the document server. [0 or 1 / 0 / 1] 0: On, 1: Off
021	Fax	*CTL	Determines whether certification is required before a user can use the fax application. [0 or 1 / 0 / 1] 0: On, 1: Off
031	Scanner	*CTL	Determines whether certification is required before a user can use the scan applications. [0 or 1 / 0 / 1] 0: On, 1: Off
041	Printer	*CTL	Determines whether certification is required before a user can use the printer applications. [0 or 1 / 0 / 1] 0: On, 1: Off

051	SDK1	*CTL	[0 or 1 / 0 / 1] 0: ON. 1: OFF Determines whether certification is required before a user can use the SDK application or browser option.
061	SDK2		
071	SDK3		
081	Browser		

5430	Auth Dialog Message Change		
001	Message Change On/Off	*CTL	[0 or 1 / 0 / 1]
002	Message Text Download		
003	Message Text ID		

5431	External Auth User Preset		
010	Tag	*CTL	-
011	Entry		
012	Group		
020	Mail		
030	Fax		
031	Fax Sub		
032	Folder		
033	Protect Code		
034	SMTP Auth		
035	LDAP Auth		
036	SMB FTP Folder Auth		
037	Acnt Acl		
038	Document Acl		
040	Cert Crypt		
050	User Limit Count		

5481	[Authentication Error Code]		
	These SP codes determine how the authentication failures are displayed.		
001	System Log Disp	*CTL	Determines whether an error code appears in the system log after a user authentication failure occurs. [0 or 1/ 0 /1] 0: Off, 1: On
002	Panel Disp	*CTL	Determines whether an error code appears on the operation panel after a user authentication failure occurs. [0 or 1/ 1 /1] 1: On, 0: Off

5490	[MF KeyCard (Japan only)]		
001	Job Permit Setting	*CTL	Sets up operation of the machine with a keycard. [0 to 1 / 0 / 1] 0: Disabled. Cancels operation without a user code. 1: Enabled. Allows operation without a user code.
002	Count Mode Setting	*CTL	-

System SP5-xxx: 2

SP5-XXX (Mode)

5491	[Optional Counter]		
001	Detail Option	*CTL	[0 or 1 / 00000000 / 1/step] 0: Forced Job Canceling ON 1: Forced Job Canceling OFF
5501	[PM Alarm]	*CTL	-
001	PM Alarm Level		[0 to 9999 / 0 / 1 /step] 0: Alarm off 1 to 9999: Alarm goes off when Value (1 to 9999) x 1000 > PM counter
002	Original Count Alarm		[0 or 1 / 0 / -] 0: No alarm sounds 1: Alarm sounds after the number of originals passing through the ARDF > 10,000
5504	[Jam Alarm]	*CTL	-
	Sets the alarm to sound for the specified jam level (document misfeeds are not included). [0 to 3 / 3 / 1 /step] 0: Zero (Off) 1: Low (2.5K jams) 2: Medium (3K jams) 3: High (6K jams)		

5505	[Error Alarm]		
	Sets the error alarm level. The error alarm counter counts "1" when any SC is detected. However, the error alarm counter decreases by "1" when an SC is not detected during a set number of copied sheets (for example, default 1500 sheets). The error alarm occurs when the SC error alarm counter reaches "5".		
-	-	*CTL	[0 to 255 / 32 / 100 copies /step]

5507	[Supply/CC Alarm]	*CTL	-
	Enables or disables the notifying a supply call via @Remote.		
001	Paper Supply Alarm	0: Off, 1: On	
002	Staple Supply Alarm	0: Off, 1: On	
003	Toner Supply Alarm	0: Off, 1: On	
006	Waste Toner Bottle Supply Alarm	0: Off, 1: On, 2: ??	
080	Toner Call Timing	Changes the timing of the "Toner Supply Call" via the @Remote, when the following conditions occur. 0: At replacement 1: At near end	
081	Toner Call Threshold	10%	
128	Interval :Others	[250 to 10000 / 1000 / 1 /step]	
133	Interval :A4		
134	Interval :A5		
142	Interval :B5		
164	Interval :LG		
166	Interval :LT		
172	Interval :HLT		

5508*	[CC Call]	*CTL	-
-------	------------------	------	---

001*	Jam Remains	0: Disable, 1: Enable
	Enables/disables initiating a call for an unattended paper jam.	
002*	Continuous Jams	0: Disable, 1: Enable
	Enables/disables initiating a call for consecutive paper jams.	
003*	Continuous Door Open	0: Disable, 1: Enable
	Enables/disables initiating a call when the front door remains open.	
011*	Jam Detection: Time Length	[3 to 30 / 10 / 1 minute /step]
	Sets the time a jam must remain before it becomes an "unattended paper jam". This setting is enabled only when SP5508-004 is set to "1".	
012*	Jam Detection: Continuous Count	[2 to 10 / 5 / 1 /step]
	Sets the number of consecutive paper jams required to initiate a call. This setting is enabled only when SP5508-004 is set to "1".	
013*	Door Open: Time Length	[3 to 30 / 10 / 1 /step]
	Sets the length of time the door remains open before the machine initiates a call. This setting is enabled only when SP5-508-004 is set to "1".	

5515	[SC/Alarm Setting]	
	With @Remote in use, these SP codes can be set to issue an SC call when an SC error occurs. If this SP is switched off, the SC call is not issued when an SC error occurs.	
001	SC Call	[0 or 1 / 1 / -] 0: Off, 1: On
002	Service Parts Near End Call	[0 or 1 / 0 / -]
003	Service Parts End Call	0: Off, 1: On
004	User Call	[0 or 1 / 1 / -] 0: Off, 1: On
006	Communication Test Call	
007	Machine Information Notice	
008	Alarm Notice	[0 or 1 / 1 / -] 0: Off, 1: On

009	Non Genuin Tonner Alarm	[0 or 1 / 1 / -] 0: Off, 1: On
010	Supply Automatic Ordering Call	
011	Supply Manegement Report Call	
012	Jam/Door Open Call	

Note

- Memory Clear (SP5-801)
- The following tables list the items that are cleared. The serial number information, meter charge setting and meter charge counters are not cleared.

5516	[Individual PM Part Alarm Call]		
001	Disable/ Enable Setting		[0 or 1 / 1 / -] 0: Not Send, 1: Send
004	Percent yield for triggering PM alert		75

5517	[Get Machine Information]		
001	Get SMC Info: Retry Interval	CTL *	[0 to 255 / 10 / 1 minute/step] When SMC info collect is interrupt, retries during the time between receiving Request for obtaining SMC info, to value set with this setting.

5610	[Base Gamma Control Point: Execute]		
004	Get Factory Default	-	-
	Recalls the factory settings.		
005	Set Factory Default	-	-
	Overwrites the current values onto the factory settings.		
006	Restore Original Value	-	-
	Recalls the previous settings.		

5611	[Toner Color in 2C]		
-------------	----------------------------	--	--

001	B-C	*ENG	[0 to 128 / 100 / 1 /step] 128: Darkest density
	Adjusts the Cyan correction value of the blue signal in two-color mode.		
002	B-M	*ENG	[0 to 128 / 100 / 1 /step] 128: Darkest density
	Adjusts the Magenta correction value of the blue signal in two-color mode.		
003	G-C	*ENG	[0 to 128 / 100 / 1 /step] 128: Darkest density
	Adjusts the Cyan correction value of the blue signal in two-color mode.		
004	G-Y	*ENG	[0 to 128 / 100 / 1 /step] 128: Darkest density
	Adjusts the Yellow correction value of the blue signal in two-color mode.		
005	R-M	*ENG	[0 to 128 / 100 / 1 /step] 128: Darkest density
	Adjusts the Magenta correction value of the blue signal in two-color mode.		
006	R-Y	*ENG	[0 to 128 / 100 / 1 /step] 128: Darkest density
	Adjusts the Yellow correction value of the blue signal in two-color mode.		

5618	[Color Mode Display Selection]		
001	-	*CTL	[0 or 1 / 1 / -] 0: ACS, Colour, Black & White, Two Colour, Single colour 1: ACD, Full Colour, Black & White
	Selects the color selection display on the LCD.		

Note

- Memory Clear (SP5-801)
- The following tables list the items that are cleared. The serial number information, meter charge setting and meter charge counters (SP8-581, 582, 583, 584, and 586) are not cleared.

5728	[Network Setting]		
001	NAT Machine Port 1 [1 to 65535/ 49101 /1 Step]		
002	NAT UI Port 1 [1 to 65535/ 55101 /1 Step]		
003	NAT Machine Port 2 [1 to 65535/ 49102 /1 Step]		
004	NAT UI Port 2 [1 to 65535/ 55102 /1 Step]		
005	NAT Machine Port 3 [1 to 65535/ 49103 /1 Step]		
006	NAT UI Port 3 [1 to 65535/ 55103 /1 Step]		
007	NAT Machine Port 4 [1 to 65535/ 49104 /1 Step]		
008	NAT UI Port 4 [1 to 65535/ 55104 /1 Step]		
009	NAT Machine Port 5 [1 to 65535/ 49105 /1 Step]		
010	NAT UI Port 5 [1 to 65535/ 55105 /1 Step]		
011	NAT Machine Port 6 [1 to 65535/ 49106 /1 Step]		
012	NAT UI Port 6 [1 to 65535/ 55106 /1 Step]		
013	NAT Machine Port 7 [1 to 65535/ 49107 /1 Step]		
014	NAT UI Port 7 [1 to 65535/ 55107 /1 Step]		
015	NAT Machine Port 8 [1 to 65535/ 49108 /1 Step]		
016	NAT UI Port 8 [1 to 65535/ 55108 /1 Step]		
017	NAT Machine Port 9 [1 to 65535/ 49109 /1 Step]		
018	NAT UI Port 9 [1 to 65535/ 55109 /1 Step]		
019	NAT Machine Port 10 [1 to 65535/ 49110 /1 Step]		
020	NAT UI Port 10 [1 to 65535/ 55110 /1 Step]		

5730	[Extended Function Setting]		
001	JavaTM Platform setting	*CTL	[0 or 1 / 1 / 1/step] 0: OFF 1: ON

010	Expiration Prior Alarm Set	*CTL	[0 to 999 / 20 / 1day/step]
5731	[Counter Effect]		
001	Change Mk1 Cnt (Paper -> Combine)	*CTL	[0 or 1 / 0 / 1/step] 0: OFF 1: ON
5734	[PDF Setting]		
	Limits PDF file type when operating Scan to, fax send, and web download.		
001	PDF/A Fixed	*CTL	[0 or 1 / 0 / 1/step] 0: non-fixed setting 1: fixed setting
5741	[Node Authentication Timeout]		
	[1 to 255/ 60 /1 sec.]		
5743	[Network Security Level]		
101	MAIN : reference	*CTL	[0x01 to 0x10 / 0x01 / 1bit/step] Returns current network security level for reference. 0x01 : custom 0x02 : Level 0 0x04 : Level 1 0x08 : FIPS 0x10 : Level 2

201	MAIN : setting	*CTL	<p>[0x01 to 0x10 / 0x01 / 1bit/step]</p> <p>Returns current network security level for setting.</p> <p>0x01 : custom</p> <p>0x02 : Level 0</p> <p>0x04 : Level 1</p> <p>0x08 : FIPS</p> <p>0x10 : Level 2</p>
-----	----------------	------	---

5745	[EcoCount Time]		
	Sets and aggregate time of eco counter.		
005	AutoClearIntervalDays	*CTL	[0 to 9999 / 0 / 1/step]
211	Controller Standby	*CTL	[0 to 9999 / 0 / 1/step]
212	STR	*CTL	[0 to 9999 / 0 / 1/step]
213	Main Power Off	*CTL	[0 to 9999 / 0 / 1/step]
214	Scanning and Printing	*CTL	[0 to 9999 / 0 / 1/step]
215	Printing	*CTL	[0 to 9999 / 0 / 1/step]
216	Scanning	*CTL	[0 to 9999 / 0 / 1/step]
217	Engine Standby	*CTL	[0 to 9999 / 0 / 1/step]
218	Low Power Consumption	*CTL	[0 to 9999 / 0 / 1/step]
219	Silent condition	*CTL	[0 to 9999 / 0 / 1/step]
220	Heater off	*CTL	[0 to 9999 / 0 / 1/step]

5747	[Browser Setting] DFU		
001	Use Cache File		
002	Cache Size		
003	Cache Clear		
011	Default HTTP Request Method		

021	User Agent
031	Use JavaScript
032	Use Extended JavaScript
041	Keep History
042	History Period
051	Use Proxy
052	Proxy Server Name
053	Proxy Port
054	Proxy User Name
055	Proxy Password
056	Hosts Not Using Proxy
061	Accept Cookie
071	Show URL Bar
072	Show Horizontal Scroll
081	Home Page
181	User Permits Home Page
182	User: Bookmark
183	User: Proxy
184	User: History
185	User: Screen Settings
201	JPEG Quality
202	Number of Common Bookmarks
203	Extended Memory Limit
204	Vertical Scroll Display Setting
205	Warning Combination Setting
206	Browser Setting 3

207	Browser Setting 4
208	Browser Setting 5
209	Browser Setting 6
210	Browser Setting 7
211	Browser Setting 8
212	Browser Setting 9
213	Browser Setting 10

5748	[OpePanel Setting]		
	Sets operation of related operational panel		
101	Op Type Action Setting	*CTL	[0 to 0xFF / 00000000 / 1/step] Bit0: reconnect operation setting 1: reconnect operation ON 0: reconnect operation Off Bit1: Job stop setting at operational panel communication shut down. 1: Job stop 0: Job duration
201	Cheetah Panel Connect Setting	*CTL	[0 to 1 / 0 / 1/step] Enter "1" for connection of the optional Smart Operation Panel.

5749	[Import/Export]		
001	Export	*CTL	Target: System, Printer, Fax, Scanner Option: Unique, Secret Crypt config: Encryption, EXECUTE
101	Import	*CTL	Option: Unique Crypt config: Encryption, EXECUTE

5751	[Key Event Encryption Setting]		
-------------	---------------------------------------	--	--

	Use the soft keyboard to set encryption key information.		
001	Password	*CTL	[32 characters / - / 1/step]

5752	[Copy:FlairAPI Setting] Sets copy FlairAPI functions ON/OFF.		
001	0x00 - 0xff	*CTL	[0 to 0xFF / 00011110 / 1/step] (7) 0000 0000 (1)
	Bit 0	FlairAPI server start up, 0:Off, 1: On	
	Bit 1	Access permission from FlairAPI external device, 0: Disabled, 1: Enabled	
	Bit 2	Switching dedicated IPv6, 0: Disabled, 1: Enabled	
	Bit 4	Simple UI function, 0: Disabled, 1: Enabled	
	Bit 5	Access permission from extended device in simple UI function. 0: Disabled, 1: Enabled	

5792	[MCS Debug SW]		
001	1	*CTL	[00000000 to 11111111 / 00000000 / 1/step]
002	2	*CTL	
003	3	*CTL	
004	4	*CTL	

5793	[ECS Debug SW] DFU		
001	1	*CTL	[00000000 to 11111111 / 00000000 / 1/step]

5794	[Browser Debug] DFU		
	[0 to 255/0/1] Invalid Operation		

5795	[SRM Debug SW] DFU		
001	1	*CTL	Touch [Execute]

5796	[PLN Debug SW]		
001	1	*CTL	[00000000 to 11111111 / 00000000 / 1/step]

5801	[Memory Clear]		
001	All Clear		Resets all correction data for process control and all software counters, and returns all modes and adjustments to their default values.
002	Engine		Clears the engine settings.
003	SCS		Initializes default system settings, SCS (System Control Service) settings, operation display coordinates, and ROM update information.
004	IMH Memory Clr		Initializes the IMH settings.
005	MCS		Initializes the Mcs settings.
006	Copier Application		Initializes all copier application settings.
007	Fax Application		Initializes the fax reset time, job login ID, all TX/RX settings, local storage file numbers, and off-hook timer.
008	Printer Application		<p>The following service settings:</p> <ul style="list-style-type: none"> • Bit switches • Gamma settings (User & Service) • Toner Limit <p>The following user settings:</p> <ul style="list-style-type: none"> • Tray Priority • Menu Protect • System Setting except for setting of Energy Saver • I/F Setup (I/O Buffer and I/O Timeout) • PCL Menu
009	Scanner Application		Initializes the scanner defaults for the scanner and all the scanner SP modes.
010	Web Service		Deletes the network file application management files and thumbnails, and initializes the job login ID.

011	NCS	All setting of Network Setup (User Menu) (NCS: Network Control Service)
012	R-Fax	Initializes the job login ID, SmartDeviceMonitor for Admin, job history, and local storage file numbers.
014	Clear DCS Setting	Initializes the DCS (Delivery Control Service) settings.
015	Clear UCS Setting	Initializes the UCS (User Information Control Service) settings.
016	MIRS Setting	Initializes the MIRS (Machine Information Report Service) settings.
017	CCS	Initializes the CCS (Certification and Charge-control Service) settings.
018	SRM Memory Clr	Initializes the SRM (System Resource Manager) settings.
019	LCS	Initializes the LCS settings.
020	Web Uapli	Initializes the web user application settings.
021	ECS	Initializes the ECS settings.
023	AICS	Initializes the AICS settings.
024	BROWSER	Initializes the BROWSER settings.
025	websys	Initializes the websys settings.
026	PLN	Initializes the PLN settings.
027	SAS	Initializes the SAS settings.

5803	[Input Check]	See "Input Check Table" in this section.
5804	[Output Check]	See "Output Check Table" in this section.

5805	[Anti-Condensation Heater]		
	0: Default setting. The heater is on when the main switch is off or when the machine is in energy saver mode. 1: The heater is always on.		
001	0:OFF/ 1:ON	*ENG	[0 or 1/ 0 / -]

5806	[RFID Cont. Reading] DFU		
001	Times	*ENG	[0 to 65535 / 0 / 1 time/step]
002	NOT 0	*ENG	
003	RET.	*ENG	
004	EXE.ALL	*ENG	OFF or ON
005	EXE.K	*ENG	
006	EXE.M	*ENG	
007	EXE.C	*ENG	
008	EXE.Y	*ENG	

5807	[Area Selection] DFU		
Select the area where the machine is installed.			
001	-	*ENG	[1 to 5 / 2 (NA), 3 (EU), 5 (ASIA) / 1/step] 2: NA 3: EU 5: Asia

5810	[SC Reset - Fusing SC Reset]		
	Resets a type A service call condition.  Note <ul style="list-style-type: none"> Turn the main switch off and on after resetting the SC code. 		
001	Fusing SC Reset	-	-

5811	[Machine Serial] Machine Serial Number Display		
002	Display	*ENG	Displays the machine serial number.
004	BCU	*ENG	Inputs the serial number.

5812	[Service Tel. No. Setting]		
-------------	-----------------------------------	--	--

001	Service	*CTL	-
	<p>Sets the telephone number for a service representative. This number is printed on the Counter List, which can be printed with the user's "Counter" menu.</p> <p>This can be up to 20 characters (both numbers and alphabetic characters can be input).</p>		
002	Facsimile	*CTL	-
	<p>Sets the fax or telephone number for a service representative. This number is printed on the Counter List.</p> <p>This can be up to 20 characters (both numbers and alphabetic characters can be input).</p>		
003	Supply	*CTL	-
	<p>Use this to input the telephone number of your supplier for consumables. Enter the number and press #.</p>		
004	Operation	*CTL	-
	<p>Use this to input the telephone number of your sales agency. Enter the number and press #.</p>		

System SP5-xxx: 3

SP5-XXX (Mode)

5816	[Remote Service]		
001	I/F Setting	*CTL	[0 to 2 / 2 / 1/step] 0: Remote service off 1: CSS remote service on 2: NRS remote service on
	Selects the remote service setting.		
002	CE Call	*CTL	[0 or 1 / 0 / 1/step] 0: Start of the service 1: End of the service
	Performs the CE Call at the start or end of the service.		
	<p>Note</p> <ul style="list-style-type: none"> This SP is activated only when SP 5816-001 is set to "2". 		
003	Function Flag	*CTL	[0 or 1 / 0 / 1/step] 0: Disabled, 1: Enabled
	Enables or disables the remote service function.		
004	Commnication Test Call	CTL	[- / - / -] [Execute]
005	Device Information Call	CTL	[- / - / -] [Execute]
007	SSL Disable	*CTL	[0 or 1 / 0 / 1/step] 0: No. SSL used. 1: Yes. SSL not used.
	Controls if RCG (Remote Communication Gate) confirmation is done by SSL during an RCG send for the @Remote over a network interface.		

008	RCG Connect Timeout	*CTL	[1 to 90 / 30 / 1second/step]
	Sets the length of time (seconds) for the time-out when the RCG (Remote Communication Gate) connects during a call via the @Remote network.		
009	RCG Write Timeout	*CTL	[0 to 100 / 60 / 1second/step]
	Sets the length of time (seconds) for the time-out when sent data is written to the RCG during a call over the @Remote network.		
010	RCG Read Timeout	*CTL	[0 to 100 / 60 / 1second/step]
	Sets the length of time (seconds) for the timeout when sent data is written from the RCG during a call over the @Remote network.		
011	Port 80 Enable	*CTL	[0 or 1 / 0 / 1/step] 0: No. Access denied 1: Yes. Access granted.
	Controls if permission is given to get access to the SOAP method over Port 80 on the @Remote network.		
012	@Remote Communication Permission Setting	*CTL	[0 to 2 / 1 / 1/step] 0: Disabled 1: Enabled 2: Limited
013	RFU Timing	*CTL	[0 or 1 / 1 / 1/step] 0: Any status of a target machine 1: Sleep or panel off mode only
	Selects the timing for the remote firmware updating.		
014	RCG Error Cause	CTL	[0 or 1 / 0 / 1/step] 0: Initial state, normal condition 1: Error
	Displays RCG connection error. cause		
021	RCG-C Registered	*CTL	[0 or 1 / 0 / 1/step] 0: Installation not completed 1: Installation completed
	This SP displays the RCG-N installation end flag.		

023	Connect Type (N/M)	*CTL	[0 or 1 / 0 / 1/step] 0: Internet connection 1: Dial-up connection
	This SP displays and selects the RCG-N connection method.		
061	Cert Expire Timing	*CTL	[0 to 0xffffffff / 0 / 1/step]
	Proximity of the expiration of the certification.		
062	Use Proxy	*CTL	[0 or 1 / 0 / 1/step] 0: Not use 1: Use
	This SP setting determines if the proxy server is used when the machine communicates with the service center.		
063	Proxy Host	*CTL	[up to 127 / - / 1/step]
	<p>This SP sets the address of the proxy server used for communication between the RCG device and the gateway. Use this SP to set up or display the customer proxy server address.</p> <p>The address is necessary to set up the embedded RCG-N.</p> <p>Note</p> <ul style="list-style-type: none"> The address display is limited to 128 characters. Characters beyond the 128 character are ignored. This address is customer information and is not printed in the SMC report. 		
064	Proxy PortNumber	*CTL	[0 to 0xffff / 0 / 1/step]
	<p>This SP sets the port number of the proxy server used for communication between the embedded RCG-N and the gateway. This setting is necessary to set up the embedded RC Gate-N.</p> <p>Note</p> <ul style="list-style-type: none"> This port number is customer information and is not printed in the SMC report. 		

065	Proxy User Name	*CTL	[up to 31 / - / 1/step]									
	<p>This SP sets the HTTP proxy certification user name.</p> <p>Note</p> <ul style="list-style-type: none"> The length of the name is limited to 31 characters. Any character beyond the 31st character is ignored. This name is customer information and is not printed in the SMC report. 											
066	Proxy Password	*CTL	[up to 31 / - / 1/step]									
	<p>This SP sets the HTTP proxy certification password.</p> <p>Note</p> <ul style="list-style-type: none"> The length of the password is limited to 31 characters. Any character beyond the 31st character is ignored. This name is customer information and is not printed in the SMC report. 											
067	CERT: Up State	*CTL	[0 to 255 / 0 / 1/step]									
	<p>Displays the status of the certification update.</p> <table border="1"> <tr> <td>0</td> <td>The certification used by Embedded RC Gate is set correctly.</td> </tr> <tr> <td>1</td> <td>The certification request (setAuthKey) for update has been received from the GW URL and certification is presently being updated.</td> </tr> <tr> <td>2</td> <td>The certification update is completed and the GW URL is being notified of the successful update.</td> </tr> <tr> <td>3</td> <td>The certification update failed, and the GW URL is being notified of the failed update.</td> </tr> <tr> <td>4</td> <td>The period of the certification has expired and new request for an update is being sent to the GW URL.</td> </tr> </table>			0	The certification used by Embedded RC Gate is set correctly.	1	The certification request (setAuthKey) for update has been received from the GW URL and certification is presently being updated.	2	The certification update is completed and the GW URL is being notified of the successful update.	3	The certification update failed, and the GW URL is being notified of the failed update.	4
0	The certification used by Embedded RC Gate is set correctly.											
1	The certification request (setAuthKey) for update has been received from the GW URL and certification is presently being updated.											
2	The certification update is completed and the GW URL is being notified of the successful update.											
3	The certification update failed, and the GW URL is being notified of the failed update.											
4	The period of the certification has expired and new request for an update is being sent to the GW URL.											

	11	A rescue update for certification has been issued and a rescue certification setting is in progress for the rescue GW connection.
	12	The rescue certification setting is completed and the GW URL is being notified of the certification update request.
	13	The notification of the request for certification update has completed successfully, and the system is waiting for the certification update request from the rescue GW URL.
	14	The notification of the certification request has been received from the rescue GW controller, and the certification is being stored.
	15	The certification has been stored, and the GW URL is being notified of the successful completion of this event.
	16	The storing of the certification has failed, and the GW URL is being notified of the failure of this event.
	17	The certification update request has been received from the GW URL, the GW URL was notified of the results of the update after it was completed, but a certification error has been received, and the rescue certification is being recorded.
	18	The rescue certification of No. 17 has been recorded, and the GW URL is being notified of the failure of the certification update.
	CERT: Error	*CTL [0 to 255 / 0 / 1/step]
	Displays a number code that describes the reason for the request for update of the certification.	
068	0	Normal. There is no request for certification update in progress.
	1	Request for certification update in progress. The current certification has expired.
	2	An SSL error notification has been issued. Issued after the certification has expired.
	3	Notification of shift from a common authentication to an individual certification.
	4	Notification of a common certification without ID2.
	5	Notification that no certification was issued.
	6	Notification that GW URL does not exist.

069	CERT:Up ID	*CTL	[- / - / -]
	The ID of the request for certification.		
083	Firm Up Status	*CTL	[0 to 5 / 0 / 1/step] 0: waiting for receiving firmware update. 1: waiting for scheduling firmware update start. 2: waiting for user confirmation 3: preparing for device firmware update. 4: processing device firmware update. 5: termination processing
	Displays the status of the firmware update		
085	Firm Up User Check	*CTL	[- / - / -]
	This SP setting determines if the operator can confirm the previous version of the firmware before the firmware update execution. If the option to confirm the previous version is selected, a notification is sent to the system manager and the firmware update is done with the firmware files from the URL.		
086	Firmware Size	*CTL	[- / - / -]
	Allows the service technician to confirm the size of the firmware data files during the firmware update execution.		
087	CERT:Macro Ver.	CTL	[8digits / - / 1digit/step]
	Displays the macro version of the @Remote certification. This SP displays 8-digit characters.		
088	CERT:PAC Ver.	CTL	[16digits / - / 1digit/step]
	Displays the PAC version of the @Remote certification. This SP displays 16-digit characters.		
089	CERT:ID2Code	CTL	[17digits / - / 1digit/step]
	Displays ID2 for the @Remote certification. Spaces are displayed as underscores (_). Asterisks (****) indicate that no @Remote certification exists. This SP displays 17-digit characters.		

090	CERT:Subject	CTL	[17digits / - / 1digit/step]
	Displays the common name of the @Remote certification subject. CN = the following 17 bytes. Spaces are displayed as underscores (_). Asterisks (****) indicate that no DESS exists.		
091	CERT:Serial No.	CTL	[16digits / - / 1digit/step]
	Displays serial number for the NRS certification. Asterisks (****) indicate that no DESS exists. This SP displays 16-digit characters		
092	CERT:Issuer	CTL	[30digits / - / 1digit/step]
	Displays the common name of the issuer of the @Remote certification. CN = the following 30 bytes. Asterisks (****) indicate that no DESS exists.		
093	CERT:Valid Start	CTL	[10digits / - / 1digit/step]
	Displays the start time of the period for which the current @Remote certification is enabled. This SP displays 10-digit characters.		
094	CERT:Valid End	CTL	[10digits / - / 1digit/step]
	Displays the end time of the period for which the current @Remote certification is enabled. This SP displays 10-digit characters.		
095	Server CN Check	*CTL	[0 or 1 / 0 / 1/step] 0: Check strictly 1: Check easily
096	GW Host	CTL	[- / - / -]
097	GW URL Path	CTL	[- / - / -]
099	Debug RescueG/WURL Set	CTL	[- / - / -] [Execute]
102	CERT:Encrypt Level	*CTL	[1 or 2 / 1 / 1/step] 1: 512 bit 2: 2048 bit
	Displays cryptic strength of the NRS certification.		
103	Client Communication Method		

104	Client Communication Limit		
105	GW IPv6 Address		
106	GW IPv6 URL Path		
107	GW Host Name		
108	GW Host URL Path		
115	Network Information Waiting Timer		
150	Selection Country	*CTL	[0 to 10 / 1 / 1/step]
	<p>Select the country where embedded RCG-M is installed in the machine. 0: Japan, 1: USA, 2: Canada, 3: UK, 4: Germany, 5: France, 6: Italy, 7: Netherlands, 8: Belgium, 9: Luxembourg, 10: Spain</p> <p>After selecting the country, you must also set the following SP codes for embedded RCG-M:</p> <ul style="list-style-type: none"> • SP5816-153 • SP5816-154 • SP5816-161 		
151	Line Type Automatic Judgement	CTL	[- / - / -] [Execute]
	<p>Setting this SP classifies the telephone line where embedded RCG-M is connected as either dial-up (pulse dial) or push (DTMF tone) type, so embedded RCG-M can automatically distinguish the number that connects to the outside line.</p> <ul style="list-style-type: none"> • The current progress, success, or failure of this execution can be displayed with SP5816-152. • If the execution succeeded, SP5816-153 will display the result for confirmation and SP5816-154 will display the telephone number for the connection to the outside line. 		

152	Line Type Judgement Result	CTL	[0 to 255 / 0 / 1/step]
<p>Displays a number to show the result of the execution of SP5816 151. Here is a list of what the numbers mean.</p> <p>0: Success</p> <p>1: In progress (no result yet). Please wait.</p> <p>2: Line abnormal</p> <p>3: Cannot detect dial tone automatically</p> <p>4: Line is disconnected</p> <p>5: Insufficient electrical power supply</p> <p>6: Line classification not supported</p> <p>7: Error because fax transmission in progress – ioctl() occurred.</p> <p>8: Other error occurred</p> <p>9: Line classification still in progress. Please wait.</p>			
153	Selection Dial / Push	*CTL	<p>[0 or 1 / 0 / 1/step]</p> <p>0: Tone Dialing Phone</p> <p>1: Pulse Dialing Phone</p> <p>Inside Japan "2" may also be displayed:</p> <p>0: Tone Dialing Phone</p> <p>1: Pulse Dialing Phone 10PPS</p> <p>2: Pulse Dialing Phone 20PPS</p>
<p>This SP displays the classification (tone or pulse) of the telephone line to the access point for embedded RCG-M. The number displayed (0 or 1) is the result of the execution of SP5816-151. However, this setting can also be changed manually.</p>			
154	Outside Line Outgoing Number	*CTL	[4digits / - / 1digit/step]
<p>The SP sets the number that switches to PSTN for the outside connection for embedded RCG-M in a system that employs a PBX (internal line).</p> <ul style="list-style-type: none"> • If the execution of SP5816-151 has succeeded and embedded RCG-M has connected to the external line, this SP display is completely blank. • If embedded RCG-M has connected to an internal line, then the number of the connection to the external line is displayed. • If embedded RCG-M has connected to an external line, a comma is displayed with the number. The comma is inserted for a 2 sec. pause. • The number setting for the external line can be entered manually (including commas). 			

156	Dial Up User Name	*CTL	[up to 32 char. / - / -/step]
	<p>Use this SP to set a user name for access to remote dial up. Follow these rules when setting a user name:</p> <ul style="list-style-type: none"> • Name length: Up to 32 characters • Spaces and # allowed but the entire entry must be enclosed by double quotation marks (""). 		
157	Dial Up Password	*CTL	[up to 32 char. / - / -/step]
	<p>Use this SP to set a password for access to remote dial up. Follow these rules when setting a user name:</p> <ul style="list-style-type: none"> • Name length: Up to 32 characters • Spaces and # allowed but the entire entry must be enclosed by double quotation marks (""). 		
161	Local Phone Number	*CTL	[up to 24 numbers / - / -/step]
	<p>Use this SP to set the telephone number of the line where embedded RCG-M is connected. This number is transmitted to and used by the Call Center to return calls. Limit: 24 numbers (numbers only)</p>		
162	Connection Timing Adjustment Incoming	*CTL	[0 to 24 / 1 / 1/step]
	<p>When the Call Center calls out to an embedded RCG-M modem, it sends a repeating ID tone (*#1#). This SP sets the time the line remains open to send these ID tones after the number of the embedded RCG-M modem is dialed up and connected.</p> <p>The actual amount of time is this setting x 2 sec. For example, if you set "2" the line will remain open for 4 sec.</p>		
163	Access Point	*CTL	up to 16 char.
	<p>This is the number of the dial-up access point for RCG-M. If no setting is done for this SP code, then a preset value (determined by the country selected) is used.</p> <p>Default: 0</p> <p>Allowed: Up to 16 alphanumeric characters</p>		

	Line Connecting	*CTL	[0 to 1 / 0 / 1/step] 0: Sharing Fax 1: No Sharing Fax
164	<p>This SP sets the connection conditions for the customer. This setting dedicates the line to RCG-M only, or sets the line for sharing between RCG-M and a fax unit.</p> <p>Note</p> <ul style="list-style-type: none"> If this setting is changed, the copier must be cycled off and on. SP5816 187 determines whether the off-hook button can be used to interrupt a RCG-M transmission in progress to open the line for fax transaction. 		
173	Modem Serial No.	*CTL	[- / - / -]
	This SP displays the serial number registered for the RCG-M.		
	Retransmission Ringing	CTL	[- / - / -] [Execute]
174	<p>Normally, it is best to allow unlimited time for certification and ID2 update requests, and for the notification that the certification has been completed. However, RCG-M generates charges based on transmission time for the customer, so a limit is placed upon the time allowed for these transactions.</p> <p>If these transactions cannot be completed within the allowed time, do this SP to cancel the time restriction.</p>		
186	RCG-C M DebugBitSW	CTL	[0000000 to 11111111 / 00000000 / -]
187	FAX TX Priority	CTL	[0 to 1 / 0 / 1/step] 0: OFF 1: ON
200	Manual Polling	CTL	[- / - / -] [Execute]
	Executes the center polling manually.		

201	Regist Status	CTL	[0 to 4 / 0 / 1/step]															
	<p>Displays a number that indicates the status of the @Remote service device.</p> <p>0: Neither the registered device by the external nor embedded RCG device is set.</p> <p>1: The embedded RCG device is being set. Only Box registration is completed. In this status, this unit cannot answer a polling request from the external RCG.</p> <p>2. The embedded RCG device is set. In this status, the external RCG unit cannot answer a polling request.</p> <p>3. The registered device by the external RCG is being set. In this status the embedded RCG device cannot be set.</p> <p>4 The registered module by the external RCG has not started.</p>																	
202	Letter Number	*CTL	[- / - / -]															
	Allows entering the number of the request needed for the RCG-N device.																	
203	Confirm Execute	CTL	[- / - / -] [Execute]															
	Executes the inquiry request to the @Remote GW URL.																	
204	Confirm Result	CTL	[0 to 255 / 0 / 1/step]															
	<p>Displays a number that indicates the result of the inquiry executed with SP5816 203.</p> <table border="0"> <tr> <td>3: Proxy error (proxy enabled)</td> <td>20: Dial-up failure (modem type only)</td> </tr> <tr> <td>4: Proxy error (proxy disabled)</td> <td>21: Ansewer tone detection failure (modem type only)</td> </tr> <tr> <td>5: Proxy error (Illegal user name or password)</td> <td>22: Carrier detection failure (modem type only)</td> </tr> <tr> <td>6: Communication error</td> <td>23: Modem setting parameter error (modem type only)</td> </tr> <tr> <td>8: Other error</td> <td>24: Power supply error (modem type only)</td> </tr> <tr> <td>9: Inquiry executing</td> <td>25: Modem line disconnected (modem type only)</td> </tr> <tr> <td>11: Registration number error (already registered number)</td> <td>26: Busy line (modem type only)</td> </tr> <tr> <td>12: Registration number error (parameter error)</td> <td></td> </tr> </table>			3: Proxy error (proxy enabled)	20: Dial-up failure (modem type only)	4: Proxy error (proxy disabled)	21: Ansewer tone detection failure (modem type only)	5: Proxy error (Illegal user name or password)	22: Carrier detection failure (modem type only)	6: Communication error	23: Modem setting parameter error (modem type only)	8: Other error	24: Power supply error (modem type only)	9: Inquiry executing	25: Modem line disconnected (modem type only)	11: Registration number error (already registered number)	26: Busy line (modem type only)	12: Registration number error (parameter error)
3: Proxy error (proxy enabled)	20: Dial-up failure (modem type only)																	
4: Proxy error (proxy disabled)	21: Ansewer tone detection failure (modem type only)																	
5: Proxy error (Illegal user name or password)	22: Carrier detection failure (modem type only)																	
6: Communication error	23: Modem setting parameter error (modem type only)																	
8: Other error	24: Power supply error (modem type only)																	
9: Inquiry executing	25: Modem line disconnected (modem type only)																	
11: Registration number error (already registered number)	26: Busy line (modem type only)																	
12: Registration number error (parameter error)																		
205	Confirm Place	CTL	[- / - / -]															
	Displays the result of the notification sent to the device from the GW URL in answer to the inquiry request. Displayed only when the result is registered at the GW URL.																	

206	Register Execute	CTL	[- / - / -] [Execute]
	Executes "Embedded RCG Registration".		
207	Register Result	CTL	[0 to 255 / 0 / 1/step]
	Displays a number that indicates the registration result.		
0: Succeeded 1: Inquiry number error 2: Registration in progress 3: Proxy error (proxy enabled) 4: Proxy error (proxy disabled) 5: Proxy error (Illegal user name or password) 8: Other error 9: Registration executing 20: Dial-up failure (modem type only)		21: Answer tone detection failure (modem type only) 22: Carrier detection failure (modem type only) 23: Modem setting parameter error (modem type only) 24: Power supply error (modem type only) 25: Modem line disconnected (modem type only) 26: Busy line (modem type only)	
208	Error Code	CTL	[-2147483647 to 2147483647 / - / -/step]
	Displays a number that describes the error code that was issued when either SP5816-204 or SP5816-207 was executed.		
	Cause	Code	Meaning
	Illegal Modem Parameter	-11001	Chat parameter error
		-11002	Chat execution error
		-11003	Unexpected error
-11004		Cutting process occurred during modem communication.	
-11005		NCS reboot occurred during modem communication.	

Operation Error, Incorrect Setting	-12002	Inquiry, registration attempted without acquiring device status.
	-12003	Attempted registration without execution of an inquiry and no previous registration.
	-12004	Attempted setting with illegal entries for certification and ID2.
	-12005	@Remote communication is prohibited. The device has an Embedded RC gate-related problem.
	-12006	A confirmation request was made after the confirmation had been already completed.
	-12007	The request number used at registration was different from the one used at confirmation.
	-12008	Update certification failed because mainframe was in use.
	-12009	D2 mismatch between an individual certification and NVRAM.
	-12010	Certification area is not initialized.

	Error Caused by Response from GW URL	-2385	Attempted dial up overseas without the correct international prefix for the telephone number.	
		-2387	Not supported at the Service Center	
		-2389	Database out of service	
		-2390	Program out of service	
		-2391	Two registrations for same device	
		-2392	Parameter error	
		-2393	Basil not managed	
		-2394	Device not managed	
		-2395	Box ID for Basil is illegal	
		-2396	Device ID for Basil is illegal	
		-2397	Incorrect ID2 format	
		-2398	Incorrect request number format	
209	Install Clear	CTL	[- / - / -] [Execute]	
	Releases the machine from its embedded RCG setup.			
240	CommError Time			
241	CommError Code 1			
242	CommError Code 2			
243	CommError Code 3			
244	CommError State 1			
245	CommError State 2			
246	CommError State 3			
247	SSL Error Count			
248	Other Error Count			

250	CommLog Print	CTL	[- / - / -]
	Prints the communication log. Note <ul style="list-style-type: none"> This SP is activated only when SP 5816-021 is set to "1". 		

5821	[Remote Service SCG Setting]		
002	RCG IPv4 Address	*CTL	[00000000h to FFFFFFFFh / 00000000h / 1/step] Sets the IP address of the RCG (Remote Communication Gate) destination for call processing at the remote service center.
003	RCG Port	*CTL	[0 to 65535 / 443 / 1/step] Sets destination port number of RCG (Remote Communication Gate) at call process against center.
004	RCG IPv4 Path	*CTL	[- / /RCG/services/ - / -] Sets the URL path of the destination for processing calls to the @Remote service center. 17 Numeric characters allowed (0 to 17)
005	RCG IPv6 Address	*CTL	
006	RCG IPv6 URL Path	*CTL	
007	RCG Host name	*CTL	
008	RCT Host URL Path	*CTL	

5824	[NV-RAM Data Upload]		
	Uploads the UP and SP mode data (except for counters and the serial number) from the NVRAM to an SD card. For details, see the "NVRAM Data Upload/Download" in the "System Maintenance Reference" of the Field Service Manual.		
001	-	#	-

5825	[NV-RAM Data Download]		
	Downloads the UP and SP mode data from an SD card to the NVRAM. For details, see the "NVRAM Data Upload/Download" in the "System Maintenance Reference" of the Field Service Manual.		
001	-	#	-

5828	[Network Setting]	*CTL	-
001	IPv4 Address (Ethernet/ IEEE802.11)		
002	IPv4 Subnet Mask (Ethernet/ IEEE802.11)		
003	IPv4 Default Gateway (Ethernet/ IEEE802.11)		
006	DHCP (Ethernet/ IEEE802.11)		
021	Active IPv4 Address		
022	Active IPv4 Subnet Mask		
023	Active IPv4 Gateway Address		
050	1284 Compatibility (Centro)	Enables or disables 1284 Compatibility. 0 or 1 / 1 / 1 / step] 0: Disabled, 1: Enabled	
052	ECP (Centro)	Enables or disables ECP Compatibility. [0 or 1 / 1 / 1 / step] 0: Disabled, 1: Enabled Note • This SP is activated only when SP5-828-50 is set to "1".	
065	Job Spooling	Enables/disables Job Spooling. [0 or 1 / 0 / 1 / step] 0: Disabled, 1: Enabled	

066	Job Spooling Clear: Start Time	Treatment of the job when a spooled job exists at power on. 0: ON (Data is cleared) 1: OFF (Automatically printed)
069	Job Spooling (Protocol)	Validates or invalidates the job spooling function for each protocol. 0: Validates 1: Invalidates bit0: LPR bit1: FTP bit2: IPP bit3: SMB bit4: BMLinkS bit5: DIPRINT bit6: sftp bit7: (Reserved)
	Protocol usage	[0 or 1 / 0x00000000 / 1bit/step]
087		Shows which protocols have been used with the network. 0: Off (Not used the network with the protocol.) 1: On (Used the network with the protocol once or more.) bit0: IPsec, bit1: IPv6, bit2: IEEE 802. 1X, bit3: Wireless LAN, bit4: Security mode level setting, bit5: Appletalk, bit6: DHCP, bit7: DHCPv6, bit8: telnet, bit9: SSL, bit10: HTTPS, bit11: BMLinkS printing, bit12: diprint printing, bit13: LPR printing, bit14: ftp printing, bit15: rsh printing, bit16: SMB printing, bit17: WSD-Printer, bit18: WSD-Scanner, bit19: Scan to SMB, bit20: Scan to NCP, bit21: Reserve, bit22: Bluetooth, bit23: IEEE 1284, bit24: USB printing, bit25: Dynamic DNS, bit26: Netware printing, bit27: LLTD, bit28: IPP printing, bit29: IPP printing (SSL), bit30: ssh, bit31: sftp
090	TELNET (0: OFF 1: ON)	Enables or disables the Telnet protocol. [0 or 1 / 1 / -] 0: Disable, 1: Enable

091	Web (0: OFF 1: ON)	Enables or disables the Web operation. [0 or 1 / 1 / -] 0: Disable, 1: Enable
145	Active IPv6 Link Local Address	This is the IPv6 local address link referenced on the Ethernet or wireless LAN (802.11b) in the format: "Link Local Address" + "Prefix Length" The IPv6 address consists of a total 128 bits configured in 8 blocks of 16 bits each.
147	Active IPv6 Stateless Address 1	These SPs are the IPv6 status addresses (1 to 5) referenced on the Ethernet or wireless LAN (802.11b) in the format: "Status Address" + "Prefix Length" The IPv6 address consists of a total 128 bits configured in 8 blocks of 16 bits each.
149	Active IPv6 Stateless Address 2	
151	Active IPv6 Stateless Address 3	
153	Active IPv6 Stateless Address 4	
155	Active IPv6 Stateless Address 5	
156	IPv6 Manual Address	This SP is the IPv6 manually set address referenced on the Ethernet or wireless LAN (802.11b) in the format: "Manual Set Address" + "Prefix Length" The IPv6 address consists of a total 128 bits configured in 8 blocks of 16 bits each.
158	IPv6 Gateway Address	This SP is the IPv6 gateway address referenced on the Ethernet or wireless LAN (802.11b). The IPv6 address consists of a total 128 bits configured in 8 blocks of 16 bits each.
161	IPv6 Stateless Auto Setting	Enables or disables the automatic setting for IPv6 stateless. [0 or 1 / 1 / 1 /step] 0: Disable, 1: Enable



236	Web Item visible	Displays or does not display the Web system items. [0 x 0000 to 0 x ffff / 0 x ffff] 0: Not displayed, 1: Displayed bit0: Net RICOH bit1: Consumable Supplier bit2-15: Reserved (all)
237	Web shopping link visible	Displays or does not display the link to Net RICOH on the top page and link page of the web system. [0 to 1 / 1 / 1] 0: Not display, 1:Display
238	Web supplies Link visible	Displays or does not display the link to Consumable Supplier on the top page and link page of the web system. [0 to 1 / 1 / 1] 0: Not display, 1:Display
239	Web Link1 Name	This SP confirms or changes the URL1 name on the link page of the web system. The maximum characters for the URL name are 31 characters.
240	Web Link1 URL	This SP confirms or changes the link to URL1 on the link page of the web system. The maximum characters for the URL are 127 characters.
241	Web Link1 visible	Displays or does not display the link to URL1 on the top page of the web system. [0 to 1 / 1 / 1] 0: Not display, 1:Display
242	Web Link2 Name	Same as "-239"
243	Web Link2 URL	Same as "-240"
244	Web Link2 visible	Same as "-241"
249	DHCPv6 DUID	[- / - / -]
5832	[HDD]	*CTL -

001	HDD Formatting (ALL)	Initializes the hard disk. Use this SP mode only if there is a hard disk error.
002	HDD Formatting (IMH)	
003	HDD Formatting (Thumbnail)	
004	HDD Formatting (Job Log)	
005	HDD Formatting (Printer Fonts)	
006	HDD Formatting (User Info)	
007	Mail RX Data	
008	Mail TX Data	
009	HDD Formatting (Data for a Design)	
010	HDD Formatting (Log)	
011	HDD Formatting (Ridoc I/F)	

System SP5-xxx: 4

SP5-XXX (Mode)

5836	[Capture Settings]	*CTL	-
001	Capture Function (0:Off 1:On)	0: Disable, 1: Enable	
	With this function disabled, the settings related to the capture feature cannot be initialized, displayed, or selected.		
002	Panel Setting	0: Displayed, 1: Not displayed	
	Displays or does not display the capture function buttons.		
<p>5836-71 to 5836-78, Copier and Printer Document Reduction</p> <p>The following 6 SP modes set the default reduction for stored documents sent to the document management server via the MLB.</p> <p>Enabled only when optional MLB (Media Link Board) is installed.</p>			
071	Reduction for Copy Color	0: 1, 1: 1/2, 2: 1/3 , 3: 1/4	
072	Reduction for Copy B&W Text	0: 1 , 1: 1/2, 2: 1/3, 3: 1/4, 6: 2/3	
073	Reduction for Copy B&W Other	0: 1 , 1: 1/2, 2: 1/3, 3: 1/4, 6: 2/3	
074	Reduction for Printer Color	0: 1, 1: 1/2, 2: 1/3 , 3: 1/4	
075	Reduction for Printer B&W	0: 1 , 1: 1/2, 2: 1/3, 3: 1/4, 6: 2/3	
077	Reduction for Printer Color 1200	1: 1/2, 3: 1/4, 4: 1/6 , 5: 1/8 (2: skipped)	
078	Reduction for Printer B&W 1200	1: 1/2 , 3: 1/4, 4: 1/6, 5: 1/8 (2: skipped)	
<p>5836-81 to 5836-86, Stored document format</p> <p>The following 6 SP modes set Sets the default format for stored documents sent to the document management server via the MLB.</p> <p>Enabled only when optional MLB (Media Link Board) is installed.</p>			

081	Format for Copy Color	<p>0: JFIF/JPEG, 1: TIFF/MMR, 2: TIFF/MH, 3: TIFF/MR</p> <p> Note</p> <ul style="list-style-type: none"> This SP is not used in this model.
082	Format for Copy B&W Text	0: JFIF/JPEG, 1: TIFF/MMR, 2: TIFF/MH, 3: TIFF/MR
083	Format Copy B&W Other	0: JFIF/JPEG, 1: TIFF/MMR, 2: TIFF/MH, 3: TIFF/MR
084	Format for Printer Color	<p>0: JFIF/JPEG, 1: TIFF/MMR, 2: TIFF/MH, 3: TIFF/MR</p> <p> Note</p> <ul style="list-style-type: none"> This SP is not used in this model.
085	Format for Printer B&W	0: JFIF/JPEG, 1: TIFF/MMR, 2: TIFF/MH, 3: TIFF/MR
091	Default for JPEG	[5 to 95 / 50 / 1 /step]
	Sets the JPEG format default for documents sent to the document management server via the MLB with JPEG selected as the format. Enabled only when optional MLB (Media Link Board) is installed.	
101	Primary srv IP address	Sets the IP address for the primary capture server. This is basically adjusted by the remote system.
102	Primary srv scheme	This is basically adjusted by the remote system.
103	Primary srv port number	This is basically adjusted by the remote system.
104	Primary srv URL path	This is basically adjusted by the remote system.
111	Secondary srv IP address	Sets the IP address for the secondary capture server. This is basically adjusted by the remote system.
112	Secondary srv scheme	This is basically adjusted by the remote system.
113	Secondary srv port number	This is basically adjusted by the remote system.
114	Secondary srv URL path	This is basically adjusted by the remote system.
120	Default Reso Rate Switch	This is basically adjusted by the remote system.

121	Reso: Copy (Color)	[0 to 3 / 2 / 1/step]
	<p>Selects the resolution for color copy mode. This is basically adjusted by the remote system.</p> <p>0: 600dpi/ 1: 300dpi/ 2: 150dpi/ 3: 75dpi</p>	
122	Reso: Copy (Mono)	[0 to 5 / 3 / 1/step]
	<p>Selects the resolution for BW copy mode. This is basically adjusted by the remote system.</p> <p>0: 600dpi/ 1: 400dpi/ 2: 300dpi/ 3: 200dpi/ 4: 150dpi/ 5: 100dpi</p>	
123	Reso: Print (Color)	This is basically adjusted by the remote system. [0 to 3 / 2 / 1/step]
	<p>Selects the resolution for color print mode. This is basically adjusted by the remote system.</p> <p>0: 600dpi/ 1: 300dpi/ 2: 150dpi/ 3: 75dpi</p>	
124	Reso: Print (Mono)	This is basically adjusted by the remote system. [0 to 5 / 3 / 1/step]
	<p>Selects the resolution for BW print mode. This is basically adjusted by the remote system.</p> <p>0: 600dpi/ 1: 400dpi/ 2: 300dpi/ 3: 200dpi/ 4: 150dpi/ 5: 100dpi</p>	
126	Reso: Fax (Mono)	This is basically adjusted by the remote system. [0 to 6 / 3 / 1/step]
	<p>Selects the resolution for BW fax mode. This is basically adjusted by the remote system.</p> <p>0: 600dpi/ 1: 400dpi/ 2: 300dpi/ 3: 200dpi/ 4: 150dpi/ 5: 100dpi/ 6: 75dpi</p>	
127	Reso: Scan (Color)	This is basically adjusted by the remote system. [0 to 6 / 4 / 1/step]
	<p>Selects the resolution for color scanning mode. This is basically adjusted by the remote system.</p> <p>0: 600dpi/ 1: 400dpi/ 2: 300dpi/ 3: 200dpi/ 4: 150dpi/ 5: 100dpi/ 6: 75dpi</p>	
128	Reso: Scan (Mono)	This is basically adjusted by the remote system. [0 to 6 / 3 / 1/step]
	<p>Selects the resolution for BW scanning mode. This is basically adjusted by the remote system.</p> <p>0: 600dpi/ 1: 400dpi/ 2: 300dpi/ 3: 200dpi/ 4: 150dpi/ 5: 100dpi/ 6: 75dpi</p>	

141	All Addr Info Switch	[0 to 1 / 1 / 1]
	Switch this SP off if the system is performing slowly due to a large number of resources in use. If this SP is switched off, only 2000 documents can be queued for sending to the Capture Server. (See SP5836-142 below.) 0: Off, 1: On	
142	Stand-by Doc Max Number	[10 to 10000 / 2000 / 1]
	This SP sets the maximum number of documents to be held on stand-by before they are sent to the Capture Server. However, the maximum number (10,000) cannot be set unless SP5386-141 has been disabled (switched off).	

5840	[IEEE 802.11]		
006	Channel MAX	*CTL	<p>Sets the maximum number of channels available for data transmission via the wireless LAN. The number of channels available varies according to location. The default settings are set for the maximum end of the range for each area. Adjust the upper 4 bits to set the maximum number of channels.</p> <p>EU: [1 to 13 / 13 / 1/step] NA: [1 to 11 / 11 / 1/step] AS: [1 to 14 / 14 / 1/step]</p>
007	Channel MIN	*CTL	<p>Sets the minimum number of channels available for data transmission via the wireless LAN. The number of channels available varies according to location. The default settings are set for the minimum end of the range for each area. Adjust the lower 4 bits to set the minimum number of channels.</p> <p>EU: [1 to 13 / 1 / 1/step] NA/ AS: [1 to 11 / 1 / 1/step] AS: [1 to 14 / 14 / 1/step]</p>

011	WEP Key Select	*CTL	<p>Selects the WEP key.</p> <p>[00 to 11 / 00 / 1 binary]</p> <p>00: Key #1</p> <p>01: Key #2 (Reserved)</p> <p>10: Key #3 (Reserved)</p> <p>11: Key #4 (Reserved)</p>
045	WPA Debug Lvl	*CTL	<p>Selects the debug level for WPA authentication application.</p> <p>[1 to 3 / 3 / 1] 1: Info, 2: warning, 3: error</p> <p>This SP is displayed only when the IEEE802.11 card is installed.</p>
046	11w		<p>Displayed only if wireless LAN is installed.</p> <p>Setting affects 11w setting</p> <p>[0 to 2/0/1 Step]</p> <p>0: Disabled</p> <p>1: Priority</p> <p>2: Required</p>
047	PSK Set Type		<p>Selects the type of PSK information.</p> <p>[0 to 1/0/1 Step]</p> <p>0: Pass phrase</p> <p>1: PSK</p>
5841	[Supply Name Setting]		

001	Toner Name Setting: Black	*CTL	Specifies supply names. These appear on the screen when the user presses the Inquiry button in the user tools screen.
002	Toner Name Setting: Cyan		
003	Toner Name Setting: Yellow		
004	Toner Name Setting: Magenta		
009	Waste Toner Bottle		
011	Staple Std1		
012	Staple Std2		
013	Staple Std3		
014	Staple Std4		

5842	[GWWS Analysis] DFU		
001	Setting 1	*CTL	Default: 00000000 – do not change Netfiles: Jobs to be printed from the document server using a PC and the DeskTopBinder software
002	Setting 2	*CTL	Adjusts the debug program modesetting. Bit7: 5682 mmseg-log setting 0: Date/Hour/Minute/Second 1: Minute/Second/Msec. 0 to 6: Not used

5844	[USB]		
001	Transfer Rate	*CTL	Adjusts the USB transfer rate. [0001 or 0004 / 0004 / -] 0001: Full speed, 0004: Auto Change
002	Vendor ID	*CTL	Displays the vendor ID.
003	Product ID	*CTL	Displays the product ID.
004	Device Release Number	*CTL	Displays the device release version number.
005	Fixed USB Port	*CTL	Displays the fixed USB Port.

006	PnP Model Name	*CTL	Displays the PnP Model Name.
007	PnP Serial Number	*CTL	Displays the PnP Serial Number.
008	Mac Supply Level	*CTL	[0 or 1 / 1 / 1/step] 0: OFF 1: ON
100	Notify Unsupport	*CTL	Displays a message of the unsupported USB device for the USB host slot. [0 or 1 / 1 / -] 0: Not displayed, 1: Displayed Note <ul style="list-style-type: none"> If this SP is changed, the following message is displayed. "Incompatible USB devices have been connected. Check the USB device."

5845	[Delivery Server Setting]	*CTL	-
	Provides items for delivery server settings.		
001	FTP Port No.	[0 to 65535 / 3670 / 1 /step]	
	Sets the FTP port number used when image files to the Scan Router Server.		
002	IP Address (Primary)	Range: 000.000.000.000 to 255.255.255.255	
	Use this SP to set the Scan Router Server address. The IP address under the transfer tab can be referenced by the initial system setting.		
006	Delivery Error Display Time	[0 to 999 / 300 / 1 second /step]	
	Use this setting to determine the length of time the prompt message is displayed when a test error occurs during document transfer with the NetFile application and an external device.		

008	IP Address (Secondary)	Range: 000.000.000.000 to 255.255.255.255
	Specifies the IP address assigned to the computer designated to function as the secondary delivery server of Scan Router. This SP allows only the setting of the IP address without reference to the DNS setting.	
009	Delivery Server Model	[0 to 4/ 0 / 1 /step]
	Allows changing the model of the delivery server registered by the I/O device. 0: Unknown 1: SG1 Provided 2: SG1 Package 3: SG2 Provided 4: SG2 Package	
010	Delivery Svr. Capability	[0 to 255 / 0 / 1 /step]
	Bit7 = 1 Comment information exists	Changes the capability of the registered that the I/O device registered.
	Bit6 = 1 Direct specification of mail address possible	
	Bit5 = 1 Mail RX confirmation setting possible	
	Bit4 = 1 Address book automatic update function exists	
	Bit3 = 1 Fax RX delivery function exists	
	Bit2 = 1 Sender password function exists	
	Bit1 = 1 Function to link MK-1 user and Sender exists	
	Bit0 = 1 Sender specification required (if set to 1, Bit6 is set to "0")	
011	Delivery Svr Capability (Ext)	[0 to 255 / 0 / 1 /step]
	Changes the capability of the registered that the I/O device registered. Bit7 = 1 Address book usage limitation (Limitation for each authorized user) Bit6 = 1 RDH authorization link Bit5 to 0: Not used	
013	Server Scheme (Primary) DFU	
	This is used for the scan router program.	

014	Server Port Number (Primary) DFU
	This is used for the scan router program.
015	Server URL Path (Primary) DFU
	This is used for the scan router program.
016	Server Scheme (Secondary) DFU
	This is used for the scan router program.
017	Server Port Number (Secondary) DFU
	This is used for the scan router program.
018	Server URL Path (Secondary) DFU
	This is used for the scan router program.
022	Rapid Sending Control
	Enables or disables the prevention function for the continuous data sending error. [0 to 1 / 0 / -]
	0: Disable, 1: Enable

5846	[UCS Settings]	*CTL	-
001	Machine ID (For Delivery Server)	Displays ID	
	Displays the unique device ID in use by the delivery server directory. The value is only displayed and cannot be changed. This ID is created from the NIC MAC or IEEE 1394 EUI. The ID is displayed as either 6-byte or 8-byte binary.		
002	Machine ID Clear (For Delivery Server)	Clears ID	
	Clears the unique ID of the device used as the name in the file transfer directory. Execute this SP if the connection of the device to the delivery server is unstable. After clearing the ID, the ID will be established again automatically by cycling the machine off and on.		
003	Maximum Entries	[2000 to 20000/ 2000 /1 /step]	
	Changes the maximum number of entries that UCS can handle. If a value smaller than the present value is set, the UCS managed data is cleared, and the data (excluding user code information) is displayed.		

006	Delivery Server Retry Timer	[0 to 255 / 0 / 1 /step]
	Sets the interval for retry attempts when the delivery server fails to acquire the delivery server address book.	
007	Delivery Server Retry Times	[0 to 255 / 0 / 1 /step]
	Sets the number of retry attempts when the delivery server fails to acquire the delivery server address book.	
008	Delivery Server Maximum Entries	[2000 to 50000 / 2000 / 1 /step]
	Sets the maximum number account entries of the delivery server user information managed by UCS.	
010	LDAP Search Timeout	[1 to 255 / 60 / 1 /step]
	Sets the length of the timeout for the search of the LDAP server.	
020	WSD Maximum Entries	[5 to 250 / 250 / 1 /step]
	Sets the maximum entries for the address book of the WSD (WS-scanner).	
021	Floder Auth Change	[0 to 1 / 0 / 1]
	<p>This SP determines whether the user login information (Login User name and Password) or address (destination setting in the address book for Scan-to-SMB) is used to permit folder access. The machine must be cycled off/on for this setting to take effect if it is changed.</p> <p>0: Uses operator login information (initial value of main machine)</p> <p>1: Uses address authorization information</p>	
022	Initial Value of Upper Limit Count	[0 to 999 / 500 / 1]
	Sets the initial value of upper limit count.	
040	Addr Book Migration (USB to HDD)	
	Not used in this machine.	

	Fill Addr Acl Info.	
041	<p>This SP must be executed immediately after installation of an HDD unit in a basic machine that previously had no HDD. The first time the machine is powered on with the new HDD installed, the system automatically takes the address book from the NVRAM and writes it onto the new HDD. However, the new address book on the HDD can be accessed only by the system administrator at this stage. Executing this SP by the service technician immediately after power on grants full address book access to all users.</p>	
	<p>Procedure</p> <ol style="list-style-type: none"> 1. Turn the machine off. 2. Install a new HDD. 3. Turn the machine on. 4. The address book and its initial data are created on the HDD automatically. 5. However, at this point the address book can be accessed by only the system administrator or key operator. 6. Enter the SP mode and do SP5846-041 . After this SP executes successfully, any user can access the address book. 	
043	Addr Book Media	<p>Displays the slot number where an address book data is in.</p> <p>[0 to 30 / - /1]</p> <p>0: Unconfirmed</p> <p>1: SD Slot 1</p> <p>2: SD Slot 2</p> <p>4: USB Flash ROM</p> <p>20: HDD</p> <p>30: Nothing</p>
046	Initialize All Setting & Addr Book	[Execute]
047	Initialize Local Addr Book	Clears the local address book information, including the user code.
048	Initialize Delivery Addr Book	Clears the distribution address book information, except the user code.
049	Initialize LDAP Addr Book	Clears the LDAP address book information, except the user code.

050	Initialize All Addr Book	Clears all directory information managed by UCS, including all user codes.
051	Backup All Addr Book	Uploads all directory information to the SD card.
052	Restore All Addr Book	Downloads all directory information from the SD card.
053	Clear Backup Info	<p>Deletes the address book data from the SD card in the service slot.</p> <p>Deletes only the files that were uploaded from this machine.</p> <p>This feature does not work if the card is write-protected.</p> <p>Note</p> <ul style="list-style-type: none"> • After you do this SP, go out of the SP mode, and then turn the power off. • Do not remove the SD card until the Power LED stops flashing.
060	Search Option	
		<p>This SP uses bit switches to set up the fuzzy search options for the UCS local address book.</p> <p>Bit: Meaning</p> <p>0: Checks both upper/lower case characters</p> <p>1: Japan Only</p> <p>2: Japan Only</p> <p>3: Japan Only</p> <p>4 to 7: Not Used</p>
062	Complexity Option 1	
	[0 to 32 / 0 / 1 /step]	<p>Use this SP to set the conditions for password entry to access the local address book. Specifically, this SP limits the password entry to upper case and sets the length of the password.</p> <p>Note</p> <ul style="list-style-type: none"> • This SP does not normally require adjustment. • This SP is enabled only after the system administrator has set up a group password policy to control access to the address book.

063	Complexity Option 2 DFU	
064	Complexity Option 3 DFU	
065	Complexity Option 4 DFU	
091	FTP Auth Port Setting	Specifies the FTP port for getting a distribution server address book that is used in the identification mode. [0 to 65535 / 3671 / 1 /step]
094	Encryption Stat	Shows the status of the encryption function for the address book data.

5847	[Rep Resolution Reduction]	*CTL	-	
	SP5847-1 through SP5847-8 changes the default settings of image data transferred externally by the Net File page reference function. [0 to 5 / 2 / 1 /step]			
	SP5847-21 sets the default for JPEG image quality of image files handled by NetFile.			
	"Net files" are jobs to be printed from the document server using a PC and the DeskTopBinder software.			
	001	Rate for Copy Color	0: 1x	
	002	Rate for Copy B&W Text	1: 1/2x	
	003	Rate for Copy B&W Other	2: 1/3x	
004	Rate for Printer Color	3: 1/4x		
005	Rate for Printer B&W	4: 1/6x		
006	Rate for Printer Color 1200dpi	5: 1/8x		
		0: 1x		
		1: 1/2x		
		2: 1/3x		
		3: 1/4x		
		4: 1/6x		
		5: 1/8x		

007	Rate for Printer B&W 1200dpi	0: 1x 1: 1/2x 2: 1/3x 3: 1/4x 4: 1/6x 5: 1/8x
021	Network Quality Default for JPEG	
	Sets the default value for the quality of JPEG images sent as NetFile pages. This function is available only with the MLB (Media Link Board) option installed. [5 to 95 / 50 / 1 /step]	

5848	[Web Service]	*CTL	-
	SP5848-2 sets the 4-bit switch assignment for the access control setting. Setting of 0001 has no effect on access and delivery from Scan Router. 5848 100 sets the maximum size allowed for downloaded images. The default is equal to 1 gigabyte.		
002	Access Ctrl: Repository (only Lower 4 bits)	0000: No access control 0001: Denies access to DeskTop Binder. 0010: No writing control	
003	Access Control: Doc. Svr. Print (Lower 4 bits)	Switches access control on and off. 0000 : No access control 0001: Denies access to DeskTop Binder.	
004	Access Ctrl: user Directory (only Lower 4 bits)		
007	Access Ctrl: Comm. Log Fax (Lower 4 bits)		
009	Access Ctrl: Job Ctrl (Lower 4 bits)		

011	Access Ctrl: Device management (Lower 4 bits)	Switches access control on and off. 0000 : No access control 0001: Denies access to DeskTop Binder.
021	Access Ctrl: Delivery (Lower 4 bits)	
022	Access Ctrl: uadministration (Lower 4bits)	
024	Access Ctrl: Log Service (Lower 4bits)	
099	Repository: Download Image Setting	DFU
100	Repository: Download Image Max. Size	Specifies the max size of the image data that the machine can download. [1 to 1024 / 1024 / 1 MB /step]
217	Setting: Timing	DFU

5849	[Installation Date]	*CTL	-
001	Display	The "Counter Clear Day" has been changed to "Installation Date" or "Inst. Date".	
002	Switch to Print	Determines whether the installation date is printed on the printout for the total counter. [0 or 1 / 1 / -] 0: OFF (No Print) 1: ON (Print)	
003	Total Counter	-	

5851	[Bluetooth]
	Sets the operation mode for the Bluetooth Unit. Press either key. [0:Public] [1: Private]

5853	[Stamp Data Download]		
	Use this SP to download the fixed stamp data stored in the firmware of the ROM and copy it to the HDD. This SP can be executed as many times as required. This SP must be executed after replacing or formatting the hard disks.		
	<div style="border: 1px solid blue; border-radius: 15px; padding: 2px; display: inline-block;">  Note </div>		
	<ul style="list-style-type: none"> This SP can be executed only with the hard disks installed. 		

5856	[Remote ROM Update]		
	Allows the technician to upgrade the firmware using a local port (IEEE1284) when updating the remote ROM.		
002	Local Port	* CTL	[0 to 1 / 0 / 1/step] 0: Disable 1: Enable

5857	[Save Debug Log]	* CTL	-
001	On/Off (1:ON 0:OFF)	0: OFF, 1: ON	
	Switches the debug log feature on and off. The debug log cannot be captured until this feature is switched on.		
002	Target (2: HDD 3: SD)	2: HDD, 3: SD Card	
	Selects the storage device to save debug logs information when the conditions set with SP5-858 are satisfied. [2 to 3 / 2 / 1 /step]		
101	Debug Logging Start Date	[- / 20120101 / 1/step]	
	Sets start date of the debug log output.		
102	Debug Logging End Date	[- / 20371212 / 1/step]	
	Saves the debug log of the input SC number in memory to the SD card.		
103	Acquire All Debug Logs	[EXECUTE]	
	Obtains all debug logs.		
104	Acquire Only Controller Debug	[EXECUTE]	
	Obtains controller debug log only.		

105	Acquire Only Engine Debug Logs	[EXECUTE]
	Obtains engine debug log only.	
107	Acquire Only Opepanel Debug Logs	[EXECUTE]
	Outputs the controller debug log to the media inserted front I/F.	
120	Make LogTrace Dir	[EXECUTE]

5860	[SMTP/POP3/IMAP4]	*CTL	-
020	Partial Mail Receive Timeout	[1 to 168 / 72 / -]	
	Sets the amount of time to wait before saving a mail that breaks up during reception. The received mail is discarded if the remaining portion of the mail is not received during this prescribed time.		
021	MDN Response RFC2298 Compliance	[0 to 1 / 1 / -]	
	Determines whether RFC2298 compliance is switched on for MDN reply mail. 0: No 1: Yes		
022	SMTP Auth. From Field Replacement	[0 to 1 / 0 / -]	
	Determines whether the FROM item of the mail header is switched to the validated account after the SMTP server is validated. 0: No. "From" item not switched. 1: Yes. "From" item switched.		
025	SMTP Auth. Direct Setting	[0 or 1 / 0 / -]	

	Selects the authentication method for SMTP. Bit switch: <ul style="list-style-type: none"> • Bit 0: LOGIN • Bit 1: PLAIN • Bit 2: CRAM MD5 • Bit 3: DIGEST MD5 • Bit 4 to 7: Not used <div style="border: 1px solid blue; border-radius: 10px; padding: 2px; display: inline-block;">  Note </div> <ul style="list-style-type: none"> • This SP is activated only when SMTP authorization is enabled by UP mode. 	
026	S/MIME: MIME Header Setting	Selects the MIME header type of an E-mail sent by S/MIME. [0 to 2 / 0 / 1] 0: Microsoft Outlook Express standard 1: Internet Draft standard 2: RFC standard
028	S/MIME: Authentication Check	[0 to 1 / 0 / 1/step] 0: No (not check) 1: Yes (check)
	Specifies whether to check destination certificate when sending S/MIME mail.	

5866	[E-mail Report] DFU		
001	Report Validity	*CTL	Enables or disables the e-mail alert. [0 or 1 / 0 / -] 0: Enable, 1: Disable
005	Add Date Field	*CTL	Adds or does not add the date field to the header of the alert mail. [0 or 1 / 0 / -] 0: Not added, 1: Added

5870	[Common Key Info Writing]		
001	Writing	*CTL	Rewrites the common certification used for the @Remote.

003	Initialize	*CTL	-
	Initializes the set certification. When the GW controller board is replaced with a new one for repair, you must execute the "Initialize (-003)" and "Writing (-001)" just after the new board replacement. NOTE: Turn off and on the main power switch after the "Initialize (-003)" and "Writing (-001)" have been done.		
004	Writing: 2048bit	*CTL	-
	Writes the authentication data 2048bit (used for NRS) in the memory.		

5873	[SD Card Appli Move]		
001	Move Exec	This SP copies the application programs from the original SD card in SD card slot 2 to an SD card in SD card slot 1.	
002	Undo Exec	This SP copies back the application programs from an SD card in SD Card Slot 2 to the original SD card in SD card slot 1. Use this menu when you have mistakenly copied some programs by using "Move Exec" (SP5873-1).	

5875	[SC Auto Reboot]		
001	Reboot Setting	*CTL	Enables or disables the automatic reboot function when an SC error occurs. [0 or 1 / 0 / -] 0: The machine reboots automatically when the machine issues an SC error and logs the SC error code. If the same SC occurs again, the machine does not reboot. 1: The machine does not reboot when an SC error occurs. The reboot is not executed for Type A or C SC codes.
002	Reboot Type	*CTL	Selects the reboot method for SC. [0 or 1 / 0 / -] 0: Manual reboot, 1: Automatic reboot

5876	[Security Clear] DFU		
-------------	-----------------------------	--	--

	This SP cannot be executed in the field.		
001	All Clear		
011	Clear NCS Security Settin		
015	Clear UCS Security Setting		

5878	[Option Setup]		
001	Data Overwrite Security	-	Enables the Data Overwrite Security unit. Press "EXECUTE" on the operation panel. Then turn the machine off and on.
002	HDD Encryption	-	Enables the HDD encryption.
003	OCR Dictionary	-	Enables the optional OCR unit.

5881	[Fixed Phrase Block Erasing]		
001	-	-	Deletes the fixed phrase.

5882	[CPM Set]		
001	-	*CTL	???

5885	[Set WIM Function]		
	Close or disclose the Web Image Functions of web image monitor.		
020	Document Server ACC Ctrl	*CTL	<p>0: OFF, 1: ON</p> <p>Bit Meaning</p> <p>0: Forbid all document server access (1)</p> <p>1: Forbid user mode access (1)</p> <p>2: Forbid print function (1)</p> <p>3: Forbid fax TX (1)</p> <p>4: Forbid scan sending (1)</p> <p>5: Forbid downloading (1)</p> <p>6: Forbid delete (1)</p> <p>7: Reserved</p>

050	Document Server List Def. Style	*CTL	Selects the display type for the document box list. [0 to 2 / 0 / 1] 0: Thumbnail, 1: Icon, 2: Details
051	Document Server List Def. Lines	*CTL	Sets the number of documents to be displayed in the document box list. [5 to 20 / 10 / 1]
100	Signature Setting	*CTL	Selects whether the signature is added to the scanned documents with the WIM when they are transmitted by an e-mail. [0 to 2 / 0 / 1/step] 0: Setting for each e-mail 1: Signature for all 2: No signature
101	Set Encryption	*CTL	Determines whether the scanned documents with the WIM are encrypted when they are transmitted by an e-mail. [0 to 1 / 0 / 1] 0: Not encrypted, 1:Encryption
200	Detect Mem Leak	*CTL	This SP determines how Web Image Monitor memory leaks are handled. A "1" setting enables the function. Bit 0: Displays memory status at session timeouts. Bit 1: Displays memory status at the start/end of PF handler only. Bit 2-7: Not used

5886	[Farm Update Setting]		
	100	Skip Version Check	*CTL
	101	Skip LR Check	*CTL

5887	[SD Get Counter]		
	This SP determines whether the ROM can be updated.		
-	*CTL	<p>This SP sends a text file to an SD card inserted in SD card Slot 2 (lower slot). The operation stores. The file is stored in a folder created in the root directory of the SD card called SD_COUNTER. The file is saved as a text file (*.txt) prefixed with the number of the machine.</p> <ol style="list-style-type: none"> 1. Insert the SD card in SD card Slot 2 (lower slot). 2. Select SP5887 then touch [EXECUTE]. 3. Touch [Execute] in the message when you are prompted. 	

5888	[Personal Information Protect]		
-	*CTL	<p>Selects the protection level for logs. [0 to 1 / 0 / 1}</p> <p>0: No authentication, No protection for logs 1: No authentication, Protected logs (only an administrator can see the logs)</p>	

5893	[SDK Application Counter]		
	Displays the counter name of each SDK application.		
001 to 012	SDK-1 to SDK-12	*CTL	-

5894	[External Counter Setting] DFU		
001	Switch Charge Mode	*ENG	[0 to 2 / 0 / 1/step]

5900	[Engine Log Upload]		
001	Pattern	*ENG	<p>Specifies target module group for engine log upload. [0 to 4 / 0 / 1/step]</p>
002	Trigger	*ENG	<p>Specifies target trigger group for engine log upload. [0 to 3 / 0 / 1/step]</p>

5907	[Plug & Play Maker/Model Name]		
	<p>Selects the brand name and the production name for Windows Plug & Play. This information is stored in the NVRAM. If the NVRAM is defective, these names should be registered again.</p> <p>After selecting, press the "Original Type" key and "#" key at the same time. When the setting is completed, the beeper sounds five times.</p>		

5913	[Switchover Permission Time]		
	Print Application Timer	*CTL	[3 to 30 / 3 / 1 second /step]
002	Sets the amount of time to elapse while the machine is in standby mode (and the operation panel keys have not been used) before another application can gain control of the display.		

5967	[Copy Server Set Function]	*CTL	0 : ON, 1 : OFF
	Enables and disables the document server. This is a security measure that prevents image data from being left in the temporary area of the HDD. After changing this setting, you must switch the main switch off and on to enable the new setting.		

5973	[User Stamp Registration]	*CTL	0 : ON, 1 : OFF
	????		

5974	[Cherry Server]		
	Specifies which version of ScanRouter, "Lite" or "Full", is installed.		
001	Cherry Server	*CTL	[0 or 1 / 0 / -] 0 : Lite, 1 : Full

5985	[Device Setting]		
	The NIC and USB support features are built into the GW controller. Use this SP to enable and disable these features. In order to use the NIC and USB functions built into the controller board, these SP codes must be set to "1".		

001	On Board NIC	<p>[0 to 2 / 0 / 1 /step]</p> <p>0: Disable, 1: Enable, 2: Function limitation</p> <p>When the "Function limitation" is set, "On board NIC" is limited only for the NRS or LDAP/NT authentication.</p> <p> Note</p> <ul style="list-style-type: none"> Other network applications than NRS or LDAP/NT authentication are not available when this SP is set to "2". Even though you can change the initial settings of those network applications, the settings do not work.
002	On Board USB	<p>[0 or 1 / 0 / 1/step]</p> <p>0: Disable, 1: Enable</p>

5987	[Mech. Counter]	
001	0: OFF / 1: ON	This SP detects that a mechanical counter device is removed. If it is detected, SC610 occurs.

5990	[SP Print Mode]	
	Prints out the SMC sheets.	
001	All (Data List)	-
002	SP (Mode Data List)	-
003	User Program	-
004	Logging Data	-
005	Diagnostic Report	-
006	Non-Default	-
007	NIB Summary	-
008	Capture Log	-
021	Copier User Program	-
022	Scanner SP	-
023	Scanner User Program	-

024	SDK/J Summary	-
025	SDK/J Application Info	-
026	Printer SP	-

5992	[SP Text mode]		
	Prints the SMC report to a file on an SD card inserted into the SD card slot on the right edge of the machine operation panel. 1: front SD slot 2: back SD slot (service slot)		
001	All (Data List)	*CTL	Touch [Execute]
002	SP (Mode Data List)	*CTL	Touch [Execute]
003	User Program	*CTL	Touch [Execute] This SP for only MFP model.
004	Logging Data	*CTL	Touch [Execute]
005	Diagnostic Report	*CTL	
006	Non-Default	*CTL	
007	NIB Summary	*CTL	
008	Capture Log	*CTL	Touch [Execute] This SP for only MFP model.
021	Copier User Program	*CTL	
022	Scanner SP	*CTL	
023	Scanner User Program	*CTL	
024	SDK/J Summary	*CTL	Touch [Execute]
025	SDK/J Application Info	*CTL	Touch [Execute]
026	Printer SP mode	*CTL	This SP for only MFP model.

5998	[Fusing Warm UP]		
	Fusing ON Timing	*CTL	[- / 1 / -]

System SP6-xxx

SP6-XXX (Peripherals)

6006	[ADF Adjustment]		
	Adjusts the side-to-side and leading registration of originals with the ARDF.		
001	S to S Registration: 1st	*ENG	[-3.0 to 3.0 / 0 / 0.1 mm/step]
002	S to S Registration: 2nd		
003	Leading Edge Registration	*ENG	[-5.0 to 5.0 / 0 / 0.1 mm/step]
	Adjusts the amount of paper buckle to correct original skew for the front and rear sides.		
006	Buckle: Duplex: 2nd	*ENG	[-2.5 to 2.5 / 0 / 0.1 mm/step]
	Adjusts the erase margin at the original trailing edge.		
007	Trailing Edge Erase	*ENG	[-10 to 10 / 0 / 0.1 mm/step]
6007	[ADF INPUT Check]		
	Displays the signals received from the sensors and switches of the ARDF. Only Bit 0 is used for ADF input check (see "Input Check" in this section).		
6008	[ADF OUTPUT Check]		
	Activates the electrical components for functional check. It is not possible to activate more than one component at the same time (see "Output Check" in this section).		
6009	[ADF Free Run]		
	Performs a DF free run in simplex, duplex mode or stamp mode.		
001	Free Run: Simplex Mode	-	OFF or ON
002	Free Run: Duplex Mode	-	

6017	[DF Magnification Adj.]		
	Adjusts the magnification in the sub-scan direction for the ARDF.		
	DF Magnification Adj.	* CTL	[-5.0 to 5.0 / 0 / 0.1 %/step]

6132	[Jogger Fence Fine Adj]		
	This SP adjusts the distance between the jogger fences and the sides of the stack on the finisher stapling tray in the (Booklet) Finisher B804/B805. The adjustment is done perpendicular to the direction of paper feed.		
	003	A4T	* ENG
	005	B5T	* ENG
	008	LG-T	* ENG
	009	LT-T	* ENG
012	Other	* ENG	
			[-1.5 to 1.5 / 0 / 0.5 mm/step] + Value: Increases distance between jogger fences and the sides of the stack. - Value: Decreases the distance between the jogger fences and the sides of the stack.

6137	[Finisher Free Run]		
	Execute the finisher free run.		
	001	Free Run 1	* ENG
	002	Free Run 2	
	003	Free Run 3	
004	Free Run 4		
			[0 to 1 / 0 / 1 /step]

6145	[FIN (BLO) INPUT Check] Finisher Input Check		
	Displays the signals received from sensors and switches of the finisher (see "Input Check" in this section).		

6146	[FIN (BLO) OUPUT Check] Finisher Output Check		
	Displays the signals received from sensors and switches of the finisher (see "Output Check" in this section).		

6830	[Extra]		
------	----------------	--	--

	<p>More than the standard number of sheets can be stapled. This SP sets the additional number of sheets (This Setting + Standard Number = maximum number of sheets).</p> <ul style="list-style-type: none"> • If the number of the maximum for staples is increased, and the mechanical warranty of the unit can be guaranteed, then the setting can take effect without changing the controller software. • However, assurance that mechanical performance can be guaranteed is required before changing the setting to increase the staple load for more than the maximum in the feed/exit specifications. • Raising this setting without quality assurance could damage the machine. 		
001	Staples 0 to 50 (Initial:0)	C*	[0 to 50 / 0 / 1/step]

System SP7-xxx: 1

SP7-XXX (Data Log)

7401	[Total SC]		
	Displays the number of SC codes detected.		
001	SC Counter	*CTL	[0 to 9999 / 0 / 1/step]
002	Total SC Counter	*CTL	[0 to 9999 / 0 / 1/step]

5

7403	[SC History]		
	Logs the SC codes detected. The 10 most recently detected SC Codes are displayed on the screen and can be seen on the SMC (logging) outputs.		
	001	Latest	*CTL -
	002	Latest 1	
	003	Latest 2	
	004	Latest 3	
	005	Latest 4	
	006	Latest 5	
	007	Latest 6	
	008	Latest 7	
	009	Latest 8	
010	Latest 9		

7404	[SC990/SC991 History]		
	Logs the SC Code 990 and 991 detected. The 10 most recently detected SC Codes are displayed on the screen and can be seen on the SMC (logging) outputs.		

001	Latest	* CTL	-
002	Latest 1		
003	Latest 2		
004	Latest 3		
005	Latest 4		
006	Latest 5		
007	Latest 6		
008	Latest 7		
009	Latest 8		
010	Latest 9		

7502	[Total Paper Jam]		
	Displays the total number of jams detected.		
001	Jam Counter	* CTL	[0 to 9999 / 0 / 1 sheet/step]
002	Total Jam Counter	* CTL	[0 to 9999 / 0 / 1 sheet/step]

7503	[Total Original Jam Counter]		
	Displays the total number of original jams.		
001	Original Jam Counter	* CTL	[0 to 9999 / 0 / 1 original/step]
002	Total Original Counter	* CTL	[0 to 9999 / 0 / 1 original/step]

7504	[Paper Jam Location]		
	ON: On check, OFF: Off Check		
Displays the number of jams according to the location where jams were detected.			

001	At Power On	*CTL	For details, "Jam Detection" in main chapter.
003	Tray 1: ON	*CTL	
004	Tray 2: ON	*CTL	
005	Tray 3: ON	*CTL	
006	Tray 4: ON	*CTL	
008	Bypass Tray: ON	*CTL	
009	Duplex: ON	*CTL	
011	Vertical Transport Sn1: ON	*CTL	
012	Vertical Transport Sn2: ON	*CTL	
013	Vertical Transport Sn3: ON	*CTL	
014	Vertical Transport Sn4: ON	*CTL	
017	Registration Sensor: ON	*CTL	
018	Fusing Entrance: ON	*CTL	
019	Fusing Exit: ON	*CTL	
020	Paper Exit: ON	*CTL	
021	1 bin: Exit Sensor: ON	*CTL	
025	Duplex Exit: ON	*CTL	
026	Duplex Entrance: ON (In)	*CTL	
027	Duplex Entrance: ON (Out)	*CTL	

028	Inverter Sensor: ON (In)	*CTL	For details, "Jam Detection" in main chapter.
029	Inverter Sensor: ON (Out)	*CTL	
047	Paper Feed Sensor 1: OFF	*CTL	
048	Paper Feed Sensor 2: OFF	*CTL	
049	Paper Feed Sensor 3: OFF	*CTL	
050	Paper Feed Sensor 4: OFF	*CTL	
051	Vertical Transport Sn1: OFF	*CTL	
052	Vertical Transport Sn2: OFF	*CTL	
053	Vertical Transport Sn3: OFF	*CTL	
054	Vertical Transport Sn4: OFF	*CTL	
057	Registration Sensor: OFF	*CTL	
060	Paper Exit: OFF	*CTL	
061	1 bin: Exit Sensor: OFF	*CTL	
065	Duplex Exit: OFF	*CTL	
066	Duplex Entrance: OFF (In)	*CTL	
067	Duplex Entrance: OFF (Out)	*CTL	
068	Inverter Sensor: OFF (In)	*CTL	
069	Inverter Sensor: OFF (Out)	*CTL	

230	Finisher Entrance	*CTL	For details, "Jam Detection" in main chapter.
240	Finisher Entrance	*CTL	
241	Finisher Entrance	*CTL	
242	Finisher Exit	*CTL	
243	Finisher Jogger Motor	*CTL	
244	Finisher Shift Roller Motor	*CTL	
245	Finisher Gathering Roller Motor	*CTL	
246	Finisher Exit Guide Plate Motor	*CTL	
247	Finisher Tray Lift Motor	*CTL	
248	Finisher Stapler Motor	*CTL	
249	Finisher Pick-up Solenoid	*CTL	
250	Data Error	*CTL	

7505	[Original Jam Detection]		
	ON: On check, OFF: Off Check		
Displays the number of jams according to the location where jams were detected.			
001	At Power On	*CTL	For details, "Jam Detection" in main chapter.
004	Registration Sensor: ON	*CTL	
008	Reverse: ON (Inverter Sensor: ON)	*CTL	
054	Registration Sensor: OFF	*CTL	
058	Reverse: OFF (Inverter Sensor: OFF)	*CTL	

7506	[Jam Count by Paper Size]		
	Displays the number of jams according to the paper size.		

006	A5 LEF	*CTL	[0 to 9999 / 0 / 1 sheet/step]
044	HLT LEF		
133	A4 SEF		
134	A5 SEF		
142	B5 SEF		
164	LG SEF		
166	LT SEF		
172	HLT SEF		
255	Others		

7507	[Plotter Jam History]		
	Displays the 10 most recently detected paper jams.		
001	Latest	*CTL	-
002	Latest 1		
003	Latest 2		
004	Latest 3		
005	Latest 4		
006	Latest 5		
007	Latest 6		
008	Latest 7		
009	Latest 8		
010	Latest 9		

7508	[Original Jam History]		
	Displays the 10 most recently detected original jams.		

001	Latest	* CTL	-
002	Latest 1		
003	Latest 2		
004	Latest 3		
005	Latest 4		
006	Latest 5		
007	Latest 6		
008	Latest 7		
009	Latest 8		
010	Latest 9		

7514	[Paper Jam Location]
	Displays the total number of jams according to the location where jams were detected.
001	At Power On
003	Tray 1: On
004	Tray 2: On
005	Tray 3: On
006	Tray 4: On
008	Bypass: On
009	Duplex: On
011	Vert Trans 1: On
012	Vert Trans 2: On
013	Vert Trans 3: On
014	Vert Trans 4: On
017	Vert Trans

018	Fusing Entrance: On
019	Fusing Exit: On
020	Paper Exit: On
021	1 Bin: Exit: On
025	Duplex Exit: On
026	Duplex Entrance: On (In)
027	Duplex Entrance: On (Out)
028	Inverter Sensor: On (In)
029	Inverter Sensor: On (Out)
047	Paper Feed Sn 1: Off
048	Paper Feed Sn 2: Off
049	Paper Feed Sn 3: Off
050	Paper Feed Sn 4: Off
051	Vertical Transport Sn 1: Off
052	Vertical Transport Sn 2: Off
053	Vertical Transport Sn 3: Off
054	Vertical Transport Sn 4: Off
057	Regist Sn: Off
060	Paper Exit: Off
061	1 Bin: Exit Sensor: Off
065	Duplex Exit: Off
066	Duplex Entrance: Off (In)
067	Duplex Entrance: Off (Out)
068	Inverter Sensor: Off (In)
069	Inverter Sensor: Off (Out)
230	FIN: Paper Exit Signal Error

240	FIN: Entrance Sensor: On
241	FIN: Entrance Sensor: Off
242	FIN: Paper Exit
243	FIN: Jogger Motor
244	FIN: Shift Roller Motor
245	FIN: Position Roller Motor
246	FIN: Exit Guide Plate Motor
247	FIN: Output Tray Motor
248	FIN: Stapler Motor
249	FIN: Pressing Roller SOL
250	FIN: Job Data Error

7515	[Original Jam Detection]
	Displays the number of original jams detected.
001	At Power On
004	Registration Sensor: On
008	Reverse Sensor: On
054	Registration Sensor: Off
058	Reverse Sensor: Off

7516	[Jam Paper Size Cnt]
	Displays the number of jams according to the paper size.

006	A5 LEF	*CTL	[0000 to 9999 / 0 / 1/step]
044	HLT LEF	*CTL	
133	A4 SEF	*CTL	
134	A5 SEF	*CTL	
142	B5 SEF	*CTL	
164	LG SEF	*CTL	
166	LT SEF	*CTL	
172	HLT SEF	*CTL	
255	Others	*CTL	

7520	[Update Log]		
	Displays error history of firmware update in the past 10 times. [-001] is the latest error history, and [-010] is the most old error history.		
001	ErrorRecord1	*CTL	[1 to 255 / 0 / 1/step]
002	ErrorRecord2	*CTL	[1 to 255 / 0 / 1/step]
003	ErrorRecord3	*CTL	[1 to 255 / 0 / 1/step]
004	ErrorRecord4	*CTL	[1 to 255 / 0 / 1/step]
005	ErrorRecord5	*CTL	[1 to 255 / 0 / 1/step]
006	ErrorRecord6	*CTL	[1 to 255 / 0 / 1/step]
007	ErrorRecord7	*CTL	[1 to 255 / 0 / 1/step]
008	ErrorRecord8	*CTL	[1 to 255 / 0 / 1/step]
009	ErrorRecord9	*CTL	[1 to 255 / 0 / 1/step]
010	ErrorRecord10	*CTL	[1 to 255 / 0 / 1/step]

7624	[Part Replacement Operation ON/OFF]		
	Selects the PM maintenance for each part.		

001	PCU: Bk	*CTL	[0 or 1 / 1 / -] 0: No (Not PM maintenance) 1: Yes (PM maintenance)
002	PCU: M		
003	PCU: C		
004	PCU: Y		
005	Develoment Unit: Bk		
006	Develoment Unit: M		
007	Develoment Unit: C		
008	Develoment Unit: Y		
013	Image Transfer Belt		
014	Image Transfer Cleaning		
015	Fusing Unit		
016	PTR Unit		
017	Toner Collection Bottle		
018	Fusing Roller		
019	Fusing Belt		

System SP7-xxx: 2

SP7-XXX (Data Log)

7801	[ROM No./Firmware Version]
	Displays the ROM version numbers of the main machine and connected peripheral devices.
7803	[PM Counter Display]
	(Page, Unit, [Color])
-001 to -020	<p>Displays the number of sheets printed for each current maintenance unit.</p> <ul style="list-style-type: none"> PM counters increment based on the number of A4 (LT) LEF size sheets printed. Therefore, the A3 (DLT) Double Count is activated. The Double Count cannot be deactivated. When a unit is replaced, the machine automatically detects that the new unit is installed. Then, the current PM counter value is automatically moved to the PM Counter - Previous (SP7-906-1 to 21) and is reset to "0". The total number of sheets printed with the last unit replaced can be checked with SP7-906-1 to 19.
001	Paper
002	Page: PCU: Bk
003	Page: PCU: C
004	Page: PCU: M
005	Page: PCU: Y
006	Page: Development Unit: Bk
007	Page: Development Unit: C
008	Page: Development Unit: M
009	Page: Development Unit: Y
014	Page: Image Transfer
015	Page: Image Transfer Cleaning

016	Page: Fusing Unit
017	Page: Fusing Roller
018	Page: Fusing Belt
019	Page:PTR Unit
020	Measurement Toner Collection Bottle
-031 to -048	<p>Displays the number of revolutions of motors or clutches for each current maintenance unit. [0 to 9999999 / 0 / 1 revolution/step]</p> <p>When a unit is replaced, the machine automatically detects that the new unit is installed. Then, the current PM counter value is automatically moved to the PM Counter - Previous (SP7-906-31 to 49) and is reset to "0". The total number of revolutions made with the last unit replaced can be checked with SP7-906-31 to 49.</p>
031	Rotation: PCU: Bk
032	Rotation: PCU: C
033	Rotation: PCU: M
034	Rotation: PCU: Y
035	Rotation: Development Unit: Bk
036	Rotation: Development Unit: C
037	Rotation: Development Unit: M
038	Rotation: Development Unit: Y
043	Rotation: Image Transfer
044	Rotation: Image Transfer Cleaning
045	Rotation: Fusing Unit
046	Rotation: Fusing Roller
047	Rotation: Fusing Belt
048	Rotation: PTR Unit

049	Measurment Toner Collection Bottle
	[0 to 999999999 / - / 1 mg/step] Displays the total amount of each waste toner bottle.
-061 to -078	[0 to 255 / - / 1 %/step] Displays the value given by the following formula: (Target revolution/ Current revolution) \times 100. This shows how much of the unit's expected lifetime has been used up. The Rotation% counter is based on rotations, not prints. If the number of rotations reaches the limit, the machine enters the end condition for that unit. If the print count lifetime is reached first, the machine also enters the end condition, even though the R% counter is still less than 100%.
	061 Rotation (%): PCU: Bk
062	Rotation (%): PCU: C
063	Rotation (%): PCU: M
064	Rotation (%): PCU: Y
065	Rotation (%): Development Unit: Bk
066	Rotation (%): Development Unit: C
067	Rotation (%): Development Unit:M
068	Rotation (%): Development Unit: Y
073	Rotation (%): Image Transfer
074	Rotation (%): Image Transfer Cleaning
075	Rotation (%): Fusing Unit
076	Rotation (%): Fusing Roller
077	Rotation (%): Fusing Belt
078	Rotation (%): PTR Unit
079	Measurment (%): Toner Collection Bottle
	[0 to 255 / - / 1 %/step] Displays how much of the unit's expected lifetime has been used up.

-091 to -108	<p>Displays the value given by the following formula: $(\text{Target printouts} / \text{Current printouts}) \times 100$. This shows how much of the unit's expected lifetime has been used up.</p> <p>The Page% counter is based on printouts, not revolutions. If the number of printouts reaches the limit, the machine enters the end condition for that unit. If the revolution count lifetime is reached first, the machine also enters the end condition, even though the Page% counter is still less than 100%.</p>		
091	Page (%): PCU: Bk	*ENG	[0 to 255 / - / 1 %/step]
092	Page (%): PCU: C		
093	Page (%): PCU: M		
094	Page (%): PCU: Y		
095	Page (%): Development Unit: Bk		
096	Page (%): Development Unit: C		
097	Page (%): Development Unit: M		
098	Page (%): Development Unit: Y		
103	Page (%): Image Transfer	*ENG	[0 to 255 / - / 1 %/step]
104	Page (%): Image Transfer Cleaning		
105	Page (%): Fusing Unit		
106	Page (%): Fusing Roller		
107	Page (%): Fusing Belt		
108	Page (%): PTR Unit		
206	ADF Pickup Roller	*ENG	[0 to 255 / - / 1 page/step]
207	ADF Feed Roller		
208	ADF Friction Pad		
209	ADF Pickup Roller	*ENG	[0 to 255 / - / 1 %/step]
210	ADF Feed Roller		
211	ADF Friction Pad		

7804	[PM Counter Reset]
	(Unit, [Color])
	Clears the PM counter. Press the [#] after the machine asks "Execute?", which will store the PM counter value in SP7-906 (PM Counter - Previous) and reset the value of the current PM counter (SP7-803) to "0".
001	Paper
002	PCU: Bk
003	PCU: C
004	PCU: M
005	PCU: Y
006	PCU: All
007	Development Unit: Bk
008	Development Unit: C
009	Development Unit: M
010	Development Unit: Y
011	Development Unit: All
016	Developer: All
017	Image Transfer Belt
018	Image Transfer Cleaning Unit
019	Fusing Unit
020	Fusing Roller
021	Fusing Belt
022	PTR Unit
023	Toner Collection Bottle
100	All
206	ADF Pickup Roller

207	ADF Feed Roller
208	ADF Friction Pad

7807	[SC/Jam Counter Reset]		
	Clears the counters related to SC codes and paper jams.		
001	-	*CTL	-

7826	[MF Error Counter] Japan Only		
001	Error Total		
002	Error Staple		

7827	[MF Error Counter Clear] Japan Only		
-------------	--	--	--

7832	[Self-Diagnose Result Display]		
	Displays the result of the self diagnose for problems.		
001	-	*CTL	-

7835	[ACC Counter]		
	Displays the ACC execution times for each mode.		
001	Copy ACC	*CTL	-
002	Printer ACC		

7836	Total Memory Size		
	Displays the memory capacity of the controller system.		
001	-	*CTL	-

7840	[Service SP Entry Code Chg Hist]		
	Records dates and times of resetting / changing "Service SP mode switch code setting" for the recent 2 times. (Decides whether the record is for setting changes or resets by branch number.)		
001	Change Time :Latest	*CTL	[- / - / -]
002	Change Time : Last1	*CTL	[- / - / -]
101	Initialize Time : Latest	*CTL	[- / - / -]
102	Initialize Time : Last1	*CTL	[- / - / -]

7852	[DF Scan Glass Dust Check Counter]		
	Counts the number of occurrences (0 to 65,535) when dust was detected on the scanning glass of the ARDF or resets the dust detection counter. Counting is done only if SP4-020-1 (ARDF Scan Glass Dust Check) is switched on.		
001	Dust Detection Counter	*CTL	[0 to 9999 / - / 1 /step]
002	Dust Detection Clear Counter	*CTL	[0 to 9999 / - / 1 /step]
	Displays the number of counter clear execution (SP7852-010).		
010	Dust Detection Counter Clear	-	Clears the dust detection counter.

7853	[Replacement Counter]		
	Displays the PM parts replacement number.		
001	PCU: Bk		
002	PCU: C		
003	PCU: M		
004	PCU: Y		
005	Development Unit: Bk		
006	Development Unit: C		
007	Development Unit: M		
008	Development Unit: Y		

013	Image Transfer
014	Image Transfer Belt Cleaning
015	Fusing Unit
016	Fusing Roller
017	Fusing Belt
018	PTR Unit
019	Toner Collection Bottle
206	ADF Pickup Roller
207	ADF Feed Roller
208	ADF Friction Pad

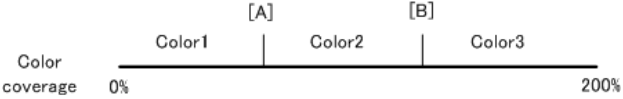
7855	[Coverage Range]		
	<p>Sets the color coverage threshold.</p> <p>Coverage rate = Coverage per page / A4 full coverage (dots) × 100</p> <p>There are three coverage counters: Color 1, Color 2, and Color 3</p> <ul style="list-style-type: none"> • [A] 5% (default) is adjustable with SP7855-001. • [B] 20% (default) is adjustable with SP7855-002.  <p>Color coverage 0% 200%</p> <p>Note</p> <ul style="list-style-type: none"> • The setting value [B] must be set larger than [A]. <p>The total numbers of printouts (BW printing plus color printing) for each coverage range are displayed with the following SPs.</p> <ul style="list-style-type: none"> • Color1 counter: SP8601-021 • Color2 counter: SP8601-022 • Color3 counter: SP8601-023 		
001	Coverage Range 1	*CTL	[1 to 200 / 5 / 1%/step]
002	Coverage Range 2	*CTL	[1 to 200 / 20 1%/step]

7901	[Assert Info]		
	Records the location where a problem is detected in the program. The data stored in this SP is used for problem analysis. DFU		
001	File Name	*CTL	-
002	Number of Lines		
003	Location		

7906	[Prev. Unit PM Counter]	
	(Page or Rotations, Unit, [Color]), Dev.: Development Unit	*ENG
001 to 019	Displays the number of sheets printed with the previous maintenance units. [0 to 9999999 / 0 / 1 page/step]	
001	Page: PCU: Bk	
002	Page: PCU: C	
003	Page: PCU: M	
004	Page: PCU: Y	
005	Page: Development Unit: Bk	
006	Page: Development Unit: C	
007	Page: Development Unit: M	
008	Page: Development Unit: Y	
013	Page: Image Transfer	
014	Page: Image Transfer Cleaning	
015	Page: Fusing Unit	
016	Page: Fusing Roller	
017	Page: Fusing Belt	
018	Page: PTR Unit	
019	Page: Toner Collection Bottle	

031 to 049	Displays the number of revolutions for motors or clutches in the previous maintenance units. [0 to 9999999 / 0 / 1 mm/step]
031	Rotation: PCU: Bk
032	Rotation: PCU: C
033	Rotation: PCU: M
034	Rotation: PCU: Y
035	Rotation: Development Unit: Bk
036	Rotation: Development Unit: C
037	Rotation: Development Unit: M
038	Rotation: Development Unit: Y
043	Rotation: Image Transfer
044	Rotation: Image Transfer Cleaning
045	Rotation: Fusing Unit
046	Rotation: Fusing Roller
047	Rotation: Fusing Belt
048	Rotation: PTR Unit
049	Measurement Toner Collection Bottle
061 to 079	Displays the number of sheets printed with the previous maintenance unit or toner cartridge. [0 to 255 / 0 / 1 %/step]
061	Rotation %: PCU: Bk
062	Rotation %: PCU: C
063	Rotation %: PCU: M
064	Rotation %: PCU: Y
065	Rotation %: Development Unit: Bk
066	Rotation %: Development Unit: C

067	Rotation %: Development Unit: M
068	Rotation %: Development Unit: Y
073	Rotation %: Image Transfer
074	Rotation %: Image Transfer Cleaning
075	Rotation %: Fusing Unit
076	Rotation %: Fusing Roller
077	Rotation %: Fusing Belt
078	Rotation %: PTR Unit
079	Measurement %: Toner Collection Bottle
091 to 108	Displays the value given by the following formula: (Yield count/ Current count) × 100, where "Current count" is the current values in the counter for the part, and "Yield count" is the recommended yield. [0 to 255 / 0 / 1 %/step]
091	Page (%): PCU: Bk
092	Page (%): PCU: C
093	Page (%): PCU: M
094	Page (%): PCU: Y
095	Page (%): Development Unit: Bk
096	Page (%): Development Unit: C
097	Page (%): Development Unit: M
098	Page (%): Development Unit: Y
103	Page (%):Image Transfer
104	Page (%):Image Transfer Cleaning
105	Page (%): Fusing Unit
106	Page (%): Fusing Roller
107	Page (%): Fusing Belt

108	Page (%): PTR Unit		
206	ADF Pickup Roller	*ENG	[0 to 255 / - / 1 page/step]
207	ADF Feed Roller		
208	ADF Friction Pad		
209	ADF Pickup Roller	*ENG	[0 to 255 / - / 1 %/step]
210	ADF Feed Roller		
211	ADF Friction Pad		

System SP7-xxx: 3

SP7-XXX (Data Log)

7931	[Toner Bottle Bk]		
	Displays the toner bottle information for Bk.		
001	Machine Serial ID	* ENG	Displays the information number for each category.
002	Cartridge Ver	* ENG	
003	Brand ID	* ENG	
004	Area ID	* ENG	
005	Product ID	* ENG	
006	Color ID	* ENG	
007	Maintenance ID	* ENG	
008	New Product Information	* ENG	
009	Recycle Counter	* ENG	
010	Date	* ENG	
011	Serial No.	* ENG	
012	Toner Remaining	* ENG	Displays the remaining toner rate. [0 to 100 / 100 / 1%/step]
013	EDP Code	* ENG	Displays the EDP CODE.
014	End History	* ENG	Displays the toner end.
015	Refill Information	* ENG	Displays the refilling record.
016	Attachment: Total Counter	* ENG	Displays the total number of sheets when replacing the new toner bottle for the b/w mode or the full color mode. [0 to 9999999 / 0 / 1/step]
017	Attachment: Color Counter	* ENG	

018	End: Total Counter	*ENG	Displays the total number of sheets when detecting the toner end for the b/w mode or the full color mode. [0 to 9999999 / 0 / 1/step]
019	End: Color Counter	*ENG	
020	Attachment Date	*ENG	Displays the date of the toner bottle attachment.
021	End Date	*ENG	Displays the date of the toner end.

7932	[Toner Bottle C]		
	Displays the toner bottle information for C.		
001	Machine Serial ID	*ENG	Displays the information number for each category.
002	Cartridge Ver	*ENG	
003	Brand ID	*ENG	
004	Area ID	*ENG	
005	Product ID	*ENG	
006	Color ID	*ENG	
007	Maintenance ID	*ENG	
008	New Product Information	*ENG	
009	Recycle Counter	*ENG	
010	Date	*ENG	
011	Serial No.	*ENG	
012	Toner Remaining	*ENG	Displays the remaining toner rate. [0 to 100 / 100 / 1%/step]
013	EDP Code	*ENG	Displays the EDP CODE.
014	End History	*ENG	Displays the toner end.
015	Refill Information	*ENG	Displays the refilling record.

016	Attachment: Total Counter	* ENG	Displays the total number of sheets when replacing the new toner bottle for the b/w mode or the full color mode. [0 to 99999999 / 0 / 1/step]
017	Attachment: Color Counter	* ENG	
018	End: Total Counter	* ENG	Displays the total number of sheets when detecting the toner end for the b/w mode or the full color mode. [0 to 99999999 / 0 / 1/step]
019	End: Color Counter	* ENG	
020	Attachment Date	* ENG	Displays the date of the toner bottle attachment.
021	End Date	* ENG	Displays the date of the toner end.

7933	[Toner Bottle M]		
	Displays the toner bottle information for M.		
001	Machine Serial ID	* ENG	Displays the information number for each category.
002	Cartridge Ver	* ENG	
003	Brand ID	* ENG	
004	Area ID	* ENG	
005	Product ID	* ENG	
006	Color ID	* ENG	
007	Maintenance ID	* ENG	
008	New Product Information	* ENG	
009	Recycle Counter	* ENG	
010	Date	* ENG	
011	Serial No.	* ENG	
012	Toner Remaining	* ENG	Displays the remaining toner rate. [0 to 100 / 100 / 1%/step]
013	EDP Code	* ENG	Displays the EDP CODE.

014	End History	*ENG	Displays the toner end.
015	Refill Information	*ENG	Displays the refilling record.
016	Attachment: Total Counter	*ENG	Displays the total number of sheets when replacing the new toner bottle for the b/w mode or the full color mode. [0 to 9999999 / 0 / 1/step]
017	Attachment: Color Counter	*ENG	
018	End: Total Counter	*ENG	Displays the total number of sheets when detecting the toner end for the b/w mode or the full color mode. [0 to 9999999 / 0 / 1/step]
019	End: Color Counter	*ENG	
020	Attachment Date	*ENG	Displays the date of the toner bottle attachment.
021	End Date	*ENG	Displays the date of the toner end.

7934	[Toner Bottle Y]		
	Displays the toner bottle information for Y.		
001	Machine Serial ID	*ENG	Displays the information number for each category.
002	Cartridge Ver	*ENG	
003	Brand ID	*ENG	
004	Area ID	*ENG	
005	Product ID	*ENG	
006	Color ID	*ENG	
007	Maintenance ID	*ENG	
008	New Product Information	*ENG	
009	Recycle Counter	*ENG	
010	Date	*ENG	
011	Serial No.	*ENG	

012	Toner Remaining	*ENG	Displays the remaining toner rate. [0 to 100 / 100 / 1%/step]
013	EDP Code	*ENG	Displays the EDP CODE.
014	End History	*ENG	Displays the toner end.
015	Refill Information	*ENG	Displays the refilling record.
016	Attachment: Total Counter	*ENG	Displays the total number of sheets when replacing the new toner bottle for the b/w mode or the full color mode. [0 to 9999999 / 0 / 1/step]
017	Attachment: Color Counter	*ENG	
018	End: Total Counter	*ENG	Displays the total number of sheets when detecting the toner end for the b/w mode or the full color mode. [0 to 9999999 / 0 / 1/step]
019	End: Color Counter	*ENG	
020	Attachment Date	*ENG	Displays the date of the toner bottle attachment.
021	End Date	*ENG	Displays the date of the toner end.

7935	[Toner Bottle Log 1: Bk]		
001	Serial No.	*ENG	Displays the toner bottle information log 1 for Bk.
002	Attachment Date		
003	Attachment: Total Counter		
004	Refill Information		
005	Serial No.	*ENG	Displays the toner bottle information log 2 for Bk.
006	Attachment Date		
007	Attachment: Total Counter		
008	Refill Information		

009	Serial No.	*ENG	Displays the toner bottle information log 3 for Bk.
010	Attachment Date		
011	Attachment: Total Counter		
012	Refill Information		
013	Serial No.	*ENG	Displays the toner bottle information log 4 for Bk.
014	Attachment Date		
015	Attachment: Total Counter		
016	Refill Information		
017	Serial No.	*ENG	Displays the toner bottle information log 5 for Bk.
018	Attachment Date		
019	Attachment: Total Counter		
020	Refill Information		

7936	[Toner Bottle Log 1: C]		
001	Serial No.	*ENG	Displays the toner bottle information log 1 for Cyan.
002	Attachment Date		
003	Attachment: Total Counter		
004	Refill Information		
005	Serial No.	*ENG	Displays the toner bottle information log 2 for Cyan.
006	Attachment Date		
007	Attachment: Total Counter		
008	Refill Information		
009	Serial No.	*ENG	Displays the toner bottle information log 3 for Cyan.
010	Attachment Date		
011	Attachment: Total Counter		
012	Refill Information		

013	Serial No.	*ENG	Displays the toner bottle information log 4 for Cyan.
014	Attachment Date		
015	Attachment: Total Counter		
016	Refill Information		
017	Serial No.	*ENG	Displays the toner bottle information log 5 for Cyan.
018	Attachment Date		
019	Attachment: Total Counter		
020	Refill Information		

7937	[Toner Bottle Log 1: M]		
001	Serial No.	*ENG	Displays the toner bottle information log 1 for Mgenta.
002	Attachment Date		
003	Attachment: Total Counter		
004	Refill Information		
005	Serial No.	*ENG	Displays the toner bottle information log 2 for Mgenta.
006	Attachment Date		
007	Attachment: Total Counter		
008	Refill Information		
009	Serial No.	*ENG	Displays the toner bottle information log 3 for Mgenta.
010	Attachment Date		
011	Attachment: Total Counter		
012	Refill Information		
013	Serial No.	*ENG	Displays the toner bottle information log 4 for Mgenta.
014	Attachment Date		
015	Attachment: Total Counter		
016	Refill Information		

017	Serial No.	*ENG	Displays the toner bottle information log 5 for Magenta.
018	Attachment Date		
019	Attachment: Total Counter		
020	Refill Information		

7938	[Toner Bottle Log 1: Y]		
001	Serial No.	*ENG	Displays the toner bottle information log 1 for Yellow.
002	Attachment Date		
003	Attachment: Total Counter		
004	Refill Information		
005	Serial No.	*ENG	Displays the toner bottle information log 2 for Yellow.
006	Attachment Date		
007	Attachment: Total Counter		
008	Refill Information		
009	Serial No.	*ENG	Displays the toner bottle information log 3 for Yellow.
010	Attachment Date		
011	Attachment: Total Counter		
012	Refill Information		
013	Serial No.	*ENG	Displays the toner bottle information log 4 for Yellow.
014	Attachment Date		
015	Attachment: Total Counter		
016	Refill Information		
017	Serial No.	*ENG	Displays the toner bottle information log 5 for Yellow.
018	Attachment Date		
019	Attachment: Total Counter		
020	Refill Information		

7950	[Unit Replacement Date]		
	Displays the replacement date of each PM unit.		
001	Image Transfer Belt	*ENG	-
002	Image Transfer Cleaning	*ENG	
003	PTR Unit	*ENG	
004	Fusing Unit	*ENG	
005	Fusing Roller	*ENG	
006	Fusing Belt	*ENG	
013	PCU: Bk	*ENG	-
014	PCU: C	*ENG	
015	PCU: M	*ENG	
016	PCU: Y	*ENG	
017	Development Unit:Bk	*ENG	-
018	Development Unit:C	*ENG	
019	Development Unit:M	*ENG	
020	Development Unit:Y	*ENG	
206	ADF Pickup Roller	*ENG	-
207	ADF Feed Roller	*ENG	
208	ADF Friction Pad	*ENG	

7951	[Remaining Day Counter]	*ENG	
	Displays the remaining unit life of each PM unit. [0 to 255 / 255 / 1 day/step]		
001	Page: PCU: Bk		
002	Page: PCU: C		
003	Page: PCU: M		

004	Page: PCU: Y
005	Page: Development Unit: Bk
006	Page: Development Unit: C
007	Page: Development Unit: M
008	Page: Development Unit: Y
013	Page: Image Transfer Belt
014	Page: Image Transfer Cleaning
015	Page: Fusing Unit
016	Page: Fusing Roller
017	Page: Fusing Belt
018	Page: PTR Unit
031	Rotation: PCU: Bk
032	Rotation: PCU: C
033	Rotation: PCU: M
034	Rotation: PCU: Y
035	Rotation: Development Unit: Bk
036	Rotation: Development Unit: C
037	Rotation: Development Unit: M
038	Rotation: Development Unit: Y
043	Rotation: Image Transfer Belt
044	Rotation: Image Transfer Cleaning
045	Rotation: Fusing Unit
046	Rotation: Fusing Roller
047	Rotation: Fusing Belt
048	Rotation: PTR Unit
049	Measurement: Toner Collection Bottle

206	ADF Pickup Roller
207	ADF Feed Roller
208	ADF Friction Pad

7952	[PM Yield Setting]		
	Adjusts the unit yield of each PM unit.		
001	Rotation: Image Transfer Belt	*ENG	[0 to 999999999 / 200696000 / 1000 mm/step]
002	Rotation: Image Transfer Cleaning	*ENG	[0 to 999999999 / 150522000 / 1000 mm/step]
003	Rotation: Fusing Unit	*ENG	[0 to 999999999 / 253311000 / 1000 mm/step]
004	Rotation: Fusing Roller	*ENG	
005	Rotation: Fusing Belt	*ENG	
006	Rotation: Paper Transfer Unit	*ENG	[0 to 999999999 / 150522000 / 1000 mm/step]
007	Measurement:Tone Collection Bottle	*ENG	[0 to 999999999 / 300000 / 1000 mg/step]
011	Page: Image Transfer Belt	*ENG	[0 to 999999 / 240000 / 1000 sheet/step]
012	Page: Image Transfer Cleaning	*ENG	[0 to 999999 / 180000 / 1000 sheet/step]
013	Page: Fusing Unit	*ENG	[0 to 999999 / 120000 / 1 sheet/step]
014	Page: Fusing Roller	*ENG	
015	Page: Fusing Belt	*ENG	
016	Page: Paper Transfer Unit	*ENG	[0 to 999999 / 180000 / 1000 sheet/step]
021	Day Threshold: PCU: Bk	*ENG	Adjusts the threshold day of the near end for each PM unit. [1 to 30 / 15 / 1 day/step] These threshold days are used for @Remote alarms.
022	Day Threshold: PCU: C	*ENG	
023	Day Threshold: PCU: M	*ENG	
024	Day Threshold: PCU: Y	*ENG	

025	Day Threshold: Development Unit: Bk	*ENG	<p>Adjusts the threshold day of the near end for each PM unit.</p> <p>[1 to 30 / 15 / 1 day/step]</p> <p>These threshold days are used for @Remote alarms.</p>
026	Day Threshold: Development Unit: C	*ENG	
027	Day Threshold: Development Unit: M	*ENG	
028	Day Threshold: Development Unit: Y	*ENG	
033	Day Threshold: Image Transfer Belt	*ENG	
034	Day Threshold: Image Transfer Cleaning	*ENG	
035	Day Threshold: Fusing Unit	*ENG	
036	Day Threshold: Fusing Roller	*ENG	
037	Day Threshold: Fusing Belt	*ENG	
038	Rotation: PCU: Bk	*ENG	
039	Rotation: PCU: C	*ENG	
040	Rotation: PCU: M	*ENG	
041	Rotation: PCU: Y	*ENG	
042	Rotation: Development Unit: Bk	*ENG	
043	Rotation: Development Unit: C	*ENG	
044	Rotation: Development Unit: M	*ENG	
045	Rotation: Development Unit: Y	*ENG	

050	Page: PCU: Bk	*ENG	[0 to 999999 / 0 / 1 sheet/step]	
051	Page: PCU: C			
052	Page: PCU: M			
053	Page: PCU: Y			
054	Page: Development Unit: Bk			*ENG
055	Page: Development Unit: C			*ENG
056	Page: Development Unit: M			*ENG
057	Page: Development Unit: Y	*ENG		
206	ADF Pickup Roller	*ENG	[0 to 999999 / 5200 / 1 page/step]	
207	ADF Feed Roller			
208	ADF Friction Pad			

7953	[Operation Env. Log: PCU: Bk]		
	Displays the PCU rotation distance in each specified operation environment. T: Temperature (°C), H: Relative Humidity (%)		
001	T<=0	*ENG	[0 to 99999999 / - / 1 mm/step]
002	0<T<=5:0<=H<30		
003	0<T<=5:30<=H<70		
004	T<=5: 70<=H<=100		
005	5<T<15: 0<=H<30		
006	5<T<15: 30<=H<55		
007	5<T<15: 55<=H<80		
008	5<T<15: 80<=H<=100		
009	15<=T<25: 0<=H<30		
010	15<=T<25: 30<=H<55		

011	15<=T<25: 55<=H<80	*ENG	[0 to 999999999 / - / 1 mm/step]
012	15<=T<25: 80<=H<=100		
013	25<=T<30: 0<=H<30		
014	25<=T<30: 30<=H<55		
015	25<=T<30: 55<=H<80		
016	25<=T<30: 80<=H<=100		
017	30<=T: 0<=H<30		
018	30<=T: 30<=H<55		
019	30<=T: 55<=H<80		
020	30<=T: 80<=H<=100		

7954	[Operation Env. Log Clear]
	Clears the operation environment log.
001	-

System SP8-xxx: 1

SP8-xxx: Data Log2

Many of these counters are provided for features that are currently not available, such as sending color faxes, and so on. However, here are some Group 8 codes that when used in combination with others, can provide useful information.

SP Numbers	What They Do
SP8211 to SP8216	The number of pages scanned to the document server.
SP8401 to SP8406	The number of pages printed from the document server
SP8691 to SP8696	The number of pages sent from the document server

5

Specifically, the following questions can be answered:

- How is the document server actually being used?
- What application is using the document server most frequently?
- What data in the document server is being reused?

Most of the SPs in this group are prefixed with a letter that indicates the mode of operation (the mode of operation is referred to as an "application"). Before reading the Group 8 Service Table, make sure that you understand what these prefixes mean.

Prefixes	What it means	
T:	Total: (Grand Total).	Grand total of the items counted for all applications (C, F, P, etc.).
C:	Copy application.	Totals (pages, jobs, etc.) executed for each application when the job was not stored on the document server.
F:	Fax application.	
P:	Print application.	
S:	Scan application.	

L:	Local storage (document server)	Totals (jobs, pages, etc.) for the document server. The L: counters work differently case by case. Sometimes, they count jobs/pages stored on the document server; this can be in document server mode (from the document server window), or from another mode, such as from a printer driver or by pressing the Store File button in the Copy mode window. Sometimes, they include occasions when the user uses a file that is already on the document server. Each counter will be discussed case by case.
O:	Other applications (external network applications, for example)	Refers to network applications such as Web Image Monitor. Utilities developed with the SDK (Software Development Kit) will also be counted with this group in the future.

5

The Group 8 SP codes are limited to 17 characters, forced by the necessity of displaying them on the small LCDs of printers and faxes that also use these SPs. Read over the list of abbreviations below and refer to it again if you see the name of an SP that you do not understand.

Key for Abbreviations

Abbreviation	What it means
/	"By", e.g. "T:Jobs/Apl" = Total Jobs "by" Application
>	More (2> "2 or more", 4> "4 or more")
AddBook	Address Book
Apl	Application
B/W	Black & White
Bk	Black
C	Cyan
ColCr	Color Create
ColMode	Color Mode
Comb	Combine
Comp	Compression
Deliv	Delivery

Abbreviation	What it means
DesApl	Designated Application. The application (Copy, Fax, Scan, Print) used to store the job on the document server, for example.
Dev Counter	Development Count, no. of pages developed.
Dup, Duplex	Duplex, printing on both sides
Emul	Emulation
FC	Full Color
FIN	Post-print processing, i.e. finishing (punching, stapling, etc.)
Full Bleed	No Margins
GenCopy	Generation Copy Mode
GPC	Get Print Counter. For jobs 10 pages or less, this counter does not count up. For jobs larger than 10 pages, this counter counts up by the number that is in excess of 10 (e.g., for an 11-page job, the counter counts up $11 - 10 = 1$)
IFax	Internet Fax
ImgEdt	Image Edit performed on the original with the copier GUI, e.g. border removal, adding stamps, page numbers, etc.
K	Black (YMCK)
LS	Local Storage. Refers to the document server.
LSize	Large (paper) Size
Mag	Magnification
MC	One color (monochrome)
NRS	New Remote Service, which allows a service center to monitor machines remotely. "NRS" is used overseas, "CSS" is used in Japan.
Org	Original for scanning
OrgJam	Original Jam

Abbreviation	What it means
Palm 2	Print Job Manager/Desk Top Editor: A pair of utilities that allows print jobs to be distributed evenly among the printers on the network, and allows files to moved around, combined, and converted to different formats.
PC	Personal Computer
PGS	Pages. A page is the total scanned surface of the original. Duplex pages count as two pages, and A3 simplex count as two pages if the A3/DLT counter SP is switched ON.
PJob	Print Jobs
Ppr	Paper
PrtJam	Printer (plotter) Jam
PrtPGS	Print Pages
R	Red (Toner Remaining). Applies to the wide format model A2 only. This machine is under development and currently not available.
Rez	Resolution
SC	Service Code (Error SC code displayed)
Scn	Scan
Sim, Simplex	Simplex, printing on 1 side.
S-to-Email	Scan-to-E-mail
SMC	SMC report printed with SP5990. All of the Group 8 counters are recorded in the SMC report.
Svr	Server
TonEnd	Toner End
TonSave	Toner Save
TXJob	Send, Transmission
YMC	Yellow, Magenta, Cyan
YMCK	Yellow, Magenta, Cyan, Black

 **Note**

- All of the Group 8 SPs are reset with SP5 801 1 Memory All Clear.

8 001	T:Total Jobs	* CTL	<p>These SPs count the number of times each application is used to do a job.</p> <p>[0 to 99999999 / 0 / 1]</p> <p>Note: The L: counter is the total number of times the other applications are used to send a job to the document server, plus the number of times a file already on the document server is used.</p>
8 002	C:Total Jobs	* CTL	
8 003	F:Total Jobs	* CTL	
8 004	P:Total Jobs	* CTL	
8 005	S:Total Jobs	* CTL	
8 006	L:Total Jobs	* CTL	

- These SPs reveal the number of times an application is used, not the number of pages processed.
- When an application is opened for image input or output, this counts as one job.
- Interrupted jobs (paper jams, etc.) are counted, even though they do not finish.
- Only jobs executed by the customer are counted. Jobs executed by the customer engineer using the SP modes are not counted.
- When using secure printing (when a password is required to start the print job), the job is counted at the time when either "Delete Data" or "Specify Output" is specified.
- A job is counted as a fax job when the job is stored for sending.
- When a fax is received to fax memory, the F: counter increments but the L: counter does not (the document server is not used).
- A fax broadcast counts as one job for the F: counter (the fax destinations in the broadcast are not counted separately).
- A fax broadcast is counted only after all the faxes have been sent to their destinations. If one transmission generates an error, then the broadcast will not be counted until the transmission has been completed.
- A printed fax report counts as one job for the F: counter.
- The F: counter does not distinguish between fax sending or receiving.
- When a copy job on the document server is printed, SP8022 also increments, and when a print job stored on the document server is printed, SP8024 also increments.
- When an original is both copied and stored on the document server, the C: and L: counters both increment.
- When a print job is stored on the document server, only the L: counter increments.
- When the user presses the Document Server button to store the job on the document server, only the L: counter increments.

- When the user enters document server mode and prints data stored on the document server, only the L: counter increments.
- When an image received from Palm 2 is received and stored, the L: counter increments.
- When the customer prints a report (user code list, for example), the O: counter increments. However, for fax reports and reports executed from the fax application, the F: counter increments.

8 011	T:Jobs/LS	* CTL	These SPs count the number of jobs stored to the document server by each application, to reveal how local storage is being used for input. [0 to 9999999 / 0 / 1] The L: counter counts the number of jobs stored from within the document server mode screen at the operation panel.
8 012	C:Jobs/LS	* CTL	
8 013	F:Jobs/LS	* CTL	
8 014	P:Jobs/LS	* CTL	
8 015	S:Jobs/LS	* CTL	
8 016	L:Jobs/LS	* CTL	
8 017	O:Jobs/LS	* CTL	

- When a scan job is sent to the document server, the S: counter increments. When you enter document server mode and then scan an original, the L: counter increments.
- When a print job is sent to the document server, the P: counter increments.
- When a network application sends data to the document server, the O: counter increments.
- When an image from Palm 2 is stored on the document server, the O: counter increments.
- When a fax is sent to the document server, the F: counter increments.

8 021	T:Pjob/LS	* CTL	These SPs reveal how files printed from the document server were stored on the document server originally. [0 to 9999999 / 0 / 1] The L: counter counts the number of jobs stored from within the document server mode screen at the operation panel.
8 022	C:Pjob/LS	* CTL	
8 023	F:Pjob/LS	* CTL	
8 024	P:Pjob/LS	* CTL	
8 025	S:Pjob/LS	* CTL	
8 026	L:Pjob/LS	* CTL	
8 027	O:Pjob/LS	* CTL	

- When a copy job stored on the document server is printed with another application, the C: counter increments.

- When an application like DeskTopBinder merges a copy job that was stored on the document server with a print job that was stored on the document server, the C: and P: counters both increment.
- When a job already on the document server is printed with another application, the L: counter increments.
- When a scanner job stored on the document server is printed with another application, the S: counter increments. If the original was scanned from within document server mode, then the L: counter increments.
- When images stored on the document server by a network application (including Palm 2), are printed with another application, the O: counter increments.
- When a copy job stored on the document server is printed with a network application (Web Image Monitor, for example), the C: counter increments.
- When a fax on the document server is printed, the F: counter increments.

8 031	T:Pjob/DesApl	*CTL	These SPs reveal what applications were used to output documents from the document server. [0 to 99999999 / 0 / 1] The L: counter counts the number of jobs printed from within the document server mode screen at the operation panel.
8 032	C:Pjob/DesApl	*CTL	
8 033	F:Pjob/DesApl	*CTL	
8 034	P:Pjob/DesApl	*CTL	
8 035	S:Pjob/DesApl	*CTL	
8 036	L:Pjob/DesApl	*CTL	
8 037	O:Pjob/DesApl	*CTL	

- When documents already stored on the document server are printed, the count for the application that started the print job is incremented.
- When the print job is started from a network application (Desk Top Binder, Web Image Monitor, etc.) the L: counter increments.

8 041	T:TX Jobs/LS	*CTL	These SPs count the applications that stored files on the document server that were later accessed for transmission over the telephone line or over a network (attached to an e-mail, or as a fax image by I-Fax). [0 to 9999999 / 0 / 1] Note: Jobs merged for sending are counted separately. The L: counter counts the number of jobs scanned from within the document server mode screen at the operation panel.
8 042	C:TX Jobs/LS	*CTL	
8 043	F:TX Jobs/LS	*CTL	
8 044	P:TX Jobs/LS	*CTL	
8 045	S:TX Jobs/LS	*CTL	
8 046	L:TX Jobs/LS	*CTL	
8 047	O:TX Jobs/LS	*CTL	

- When a stored copy job is sent from the document server, the C: counter increments.
- When images stored on the document server by a network application or Palm2 are sent as an e-mail, the O: counter increments.

8 051	T:TX Jobs/DesApl	*CTL	These SPs count the applications used to send files from the document server over the telephone line or over a network (attached to an e-mail, or as a fax image by I-Fax). Jobs merged for sending are counted separately. [0 to 9999999 / 0 / 1] The L: counter counts the number of jobs sent from within the document server mode screen at the operation panel.
8 052	C:TX Jobs/DesApl	*CTL	
8 053	F:TX Jobs/DesApl	*CTL	
8 054	P:TX Jobs/DesApl	*CTL	
8 055	S:TX Jobs/DesApl	*CTL	
8 056	L:TX Jobs/DesApl	*CTL	
8 057	O:TX Jobs/DesApl	*CTL	

- If the send is started from Desk Top Binder or Web Image Monitor, for example, then the O: counter increments.

8 061	T:FIN Jobs	*CTL	[0 to 9999999 / 0 / 1]
	These SPs total the finishing methods. The finishing method is specified by the application.		
8 062	C:FIN Jobs	*CTL	[0 to 9999999 / 0 / 1]
	These SPs total finishing methods for copy jobs only. The finishing method is specified by the application.		

8 063	F:FIN Jobs	*CTL	[0 to 99999999 / 0 / 1]
	<p>These SPs total finishing methods for fax jobs only. The finishing method is specified by the application.</p> <p>Note: Finishing features for fax jobs are not available at this time.</p>		
8 064	P:FIN Jobs	*CTL	[0 to 99999999 / 0 / 1]
	<p>These SPs total finishing methods for print jobs only. The finishing method is specified by the application.</p>		
8 065	S:FIN Jobs	*CTL	[0 to 99999999 / 0 / 1]
	<p>These SPs total finishing methods for scan jobs only. The finishing method is specified by the application.</p> <p>Note: Finishing features for scan jobs are not available at this time.</p>		
8 066	L:FIN Jobs	*CTL	[0 to 99999999 / 0 / 1]
	<p>These SPs total finishing methods for jobs output from within the document server mode screen at the operation panel. The finishing method is specified from the print window within document server mode.</p>		
8 067	O:FIN Jobs	*CTL	[0 to 99999999 / 0 / 1]
	<p>These SPs total finishing methods for jobs executed by an external application, over the network. The finishing method is specified by the application.</p>		
8 06x 1	Sort	Number of jobs started in Sort mode. When a stored copy job is set for Sort and then stored on the document server, the L: counter increments. (See SP8 066 1)	
8 06x 2	Stack	Number of jobs started out of Sort mode.	
8 06x 3	Staple	Number of jobs started in Staple mode.	
8 06x 4	Booklet	Number of jobs started in Booklet mode. If the machine is in staple mode, the Staple counter also increments.	
8 06x 5	Z-Fold	Number of jobs started In any mode other than the Booklet mode and set for folding (Z-fold).	
8 06x 6	Punch	Number of jobs started in Punch mode. When Punch is set for a print job, the P: counter increments. (See SP8 064 6.)	
8 06x 7	Other	Reserved. Not used.	

8 06x 8	Inside-Fold	Not used
8 06x 9	Three-IN-Fold	Not used
8 06x 10	Three-OUT-Fold	Not used
8 06x 11	Four-Fold	Not used
8 06x 12	KANNON-Fold	Not used
8 06x 13	Perfect-Bind	Not used
8 06x 14	Ring-Bind	Not used

8 071	T:Jobs/PGS	*CTL	[0 to 9999999/ 0 / 1]
	These SPs count the number of jobs broken down by the number of pages in the job, regardless of which application was used.		
8 072	C:Jobs/PGS	*CTL	[0 to 9999999/ 0 / 1]
	These SPs count and calculate the number of copy jobs by size based on the number of pages in the job.		
8 073	F:Jobs/PGS	*CTL	[0 to 9999999/ 0 / 1]
	These SPs count and calculate the number of fax jobs by size based on the number of pages in the job.		
8 074	P:Jobs/PGS	*CTL	[0 to 9999999/ 0 / 1]
	These SPs count and calculate the number of print jobs by size based on the number of pages in the job.		
8 075	S:Jobs/PGS		[0 to 9999999/ 0 / 1]
	These SPs count and calculate the number of scan jobs by size based on the number of pages in the job.		
8 076	L:Jobs/PGS	*CTL	[0 to 9999999/ 0 / 1]
	These SPs count and calculate the number of jobs printed from within the document server mode window at the operation panel, by the number of pages in the job.		
8 077	O:Jobs/PGS	*CTL	[0 to 9999999/ 0 / 1]
	These SPs count and calculate the number of "Other" application jobs (Web Image Monitor, Palm 2, etc.) by size based on the number of pages in the job.		

8 07x 1	1 Page	8 07x 8	21 to 50 Pages
8 07x 2	2 Pages	8 07x 9	51 to 100 Pages
8 07x 3	3 Pages	8 07x 10	101 to 300 Pages
8 07x 4	4 Pages	8 07x 11	301 to 500 Pages
8 07x 5	5 Pages	8 07x 12	501 to 700 Pages
8 07x 6	6 to 10 Pages	8 07x 13	701 to 1000 Pages
8 07x 7	11 to 20 Pages	8 07x 14	1001 to Pages

- For example: When a copy job stored on the document server is printed in document server mode, the appropriate L: counter (SP8076 0xx) increments.
- Printing a fax report counts as a job and increments the F: counter (SP 8073).
- Interrupted jobs (paper jam, etc.) are counted, even though they do not finish.
- If a job is paused and re-started, it counts as one job.
- If the finisher runs out of staples during a print and staple job, then the job is counted at the time the error occurs.
- For copy jobs (SP 8072) and scan jobs (SP 8075), the total is calculated by multiplying the number of sets of copies by the number of pages scanned. (One duplex page counts as 2.)
- The first test print and subsequent test prints to adjust settings are added to the number of pages of the copy job (SP 8072).
- When printing the first page of a job from within the document server screen, the page is counted.

8 111	T:FAX TX Jobs	*CTL	[0 to 99999999/ 0 / 1]
	These SPs count the total number of jobs (color or black-and-white) sent by fax, either directly or using a file stored on the document server, on a telephone line. Note: Color fax sending is not available at this time.		
8 113	F: FAX TX Jobs	*CTL	[0 to 99999999/ 0 / 1]
	These SPs count the total number of jobs (color or black-and-white) sent by fax directly on a telephone line. Note: Color fax sending is not available at this time.		
8 11x 1	B/W		
8 11x 2	Color		

- These counters count jobs, not pages.
- This SP counts fax jobs sent over a telephone line with a fax application, including documents stored on the document server.
- If the mode is changed during the job, the job will count with the mode set when the job started.
- If the same document is faxed to both a public fax line and an I-Fax at a destination where both are available, then this counter increments, and the I-Fax counter (8 12x) also increments.
- The fax job is counted when the job is scanned for sending, not when the job is sent.

8 121	T:IFAX TX Jobs	*CTL	[0 to 99999999 / 0 / 1]
	These SPs count the total number of jobs (color or black-and-white) sent, either directly or using a file stored on the document server, as fax images using I-Fax. Note: Color fax sending is not available at this time.		
8 123	F: IFAX TX Jobs	*CTL	[0 to 99999999 / 0 / 1]
	These SPs count the number of jobs (color or black-and-white) sent (not stored on the document server), as fax images using I-Fax. Note: Color fax sending is not available at this time.		
8 12x 1	B/W		
8 12x 2	Color		

- These counters count jobs, not pages.
- The counters for color are provided for future use; the color fax feature is not available at this time.
- The fax job is counted when the job is scanned for sending, not when the job is sent.

8 131	T:S-to-Email Jobs	*CTL	[0 to 99999999 / 0 / 1]
	These SPs count the total number of jobs (color or black-and-white) scanned and attached to an e-mail, regardless of whether the document server was used or not.		
8 135	S: S-to-Email Jobs	*CTL	[0 to 99999999 / 0 / 1]
	These SPs count the number of jobs (color or black-and-white) scanned and attached to e-mail, without storing the original on the document server.		
8 13x 1	B/W		
8 13x 2	Color		
8 13x 3	ACS		

- These counters count jobs, not pages.
- If the job is stored on the document server, after the job is stored it is determined to be color or black-and-white then counted.
- If the job is cancelled during scanning, or if the job is cancelled while the document is waiting to be sent, the job is not counted.
- If the job is cancelled during sending, it may or may not be counted, depending on what stage of the process had been reached when the job was cancelled.
- If several jobs are combined for sending to the Scan Router, Scan-to-Email, or Scan-to-PC, or if one job is sent to more than one destination. each send is counted separately. For example, if the same document is sent by Scan-to-Email as well as Scan-to-PC, then it is counted twice (once for Scan-to-Email and once for Scan-to-PC).

8 141	T:Deliv Jobs/Svr	*CTL	[0 to 9999999/ 0 / 1]
	These SPs count the total number of jobs (color or black-and-white) scanned and sent to a Scan Router server.		
8 145	S: Deliv Jobs/Svr	*CTL	[0 to 9999999/ 0 / 1]
	These SPs count the number of jobs (color or black-and-white) scanned in scanner mode and sent to a Scan Router server.		
8 14x 1	B/W		
8 14x 2	Color		
8 14x 3	ACS		

- These counters count jobs, not pages.
- The jobs are counted even though the arrival and reception of the jobs at the Scan Router server cannot be confirmed.
- If even one color image is mixed with black-and-white images, then the job is counted as a "Color" job.
- If the job is cancelled during scanning, or if the job is cancelled while the document is waiting to be delivered, the job is not counted.
- If the job is cancelled during sending, it may or may not be counted, depending on what stage of the process had been reached when the job was cancelled.
- Even if several files are combined for sending, the transmission counts as one job.

8 151	T:Deliv Jobs/PC	*CTL	[0 to 9999999/ 0 / 1]
	These SPs count the total number of jobs (color or black-and-white) scanned and sent to a folder on a PC (Scan-to-PC). Note: At the present time, 8 151 and 8 155 perform identical counts.		
8 155	S:Deliv Jobs/PC	*CTL	[0 to 9999999/ 0 / 1]
	These SPs count the total number of jobs (color or black-and-white) scanned and sent with Scan-to-PC.		
8 15x 1	B/W		
8 15x 2	Color		
8 15x 3	ACS		

- These counters count jobs, not pages.
- If the job is cancelled during scanning, it is not counted.
- If the job is cancelled while it is waiting to be sent, the job is not counted.
- If the job is cancelled during sending, it may or may not be counted, depending on what stage of the process had been reached when the job was cancelled.
- Even if several files are combined for sending, the transmission counts as one job.

8 161	T:PCFAX TX Jobs	*CTL	These SPs count the number of PC Fax transmission jobs. A job is counted from when it is registered for sending, not when it is sent. [0 to 9999999/ 0 / 1] Note: At the present time, these counters perform identical counts.
8 163	F:PCFAX TX Jobs	*CTL	

- This counts fax jobs started from a PC using a PC fax application, and sending the data out to the destination from the PC through the copier.

8 171	T:Deliv Jobs/WSD/DSM	*CTL	These SPs count the pages scanned by WS. [0 to 9999999/ 0 / 1]
8 175	S:Deliv Jobs/WSD/DSM	*CTL	
-001	B/W		

-002	Color
-003	ACS

8 181	T:Scan to Media Jobs	*CTL	These SPs count the scanned pages in a media by the scanner application. [0 to 9999999/ 0 / 1]
8 185	S:Scan to Media Jobs	*CTL	
-001	B/W		
-002	Color		
-003	ACS		

8 191	T:Total Scan PGS	*CTL	These SPs count the pages scanned by each application that uses the scanner to scan images. [0 to 9999999/ 0 / 1]
8 192	C:Total Scan PGS	*CTL	
8 193	F:Total Scan PGS	*CTL	
8 195	S:Total Scan PGS	*CTL	
8 196	L:Total Scan PGS	*CTL	

- SP 8 191 to 8 196 count the number of scanned sides of pages, not the number of physical pages.
- These counters do not count reading user stamp data, or reading color charts to adjust color.
- Previews done with a scanner driver are not counted.
- A count is done only after all images of a job have been scanned.
- Scans made in SP mode are not counted.

Examples

- If both sides of 3 A4 sheets are copied and stored to the document server using the Store File button in the Copy mode window, the C: count is 6 and the L: count is 6.
- If both sides of 3 A4 sheets are copied but not stored, the C: count is 6.
- If you enter document server mode then scan 6 pages, the L: count is 6.

8 201	T:LSize Scan PGS	*CTL	[0 to 9999999/ 0 / 1]
	These SPs count the total number of large pages input with the scanner for scan and copy jobs. Large size paper (A3/ DLT) scanned for fax transmission are not counted. Note: These counters are displayed in the SMC Report, and in the User Tools display.		

8 203	F:LSize Scan PGS	*CTL	[0 to 9999999/ 0 / 1]
	<p>These SPs count the total number of large pages input with the scanner for fax transmission.</p> <p>Note: These counters are displayed in the SMC Report, and in the User Tools display.</p>		
8 205	S:LSize Scan PGS	*CTL	[0 to 9999999/ 0 / 1]
	<p>These SPs count the total number of large pages input with the scanner for scan jobs only. Large size paper (A3/DLT) scanned for fax transmission are not counted.</p> <p>Note: These counters are displayed in the SMC Report, and in the User Tools display.</p>		

8 211	T:Scan PGS/LS	*CTL	<p>These SPs count the number of pages scanned into the document server .</p> <p>[0 to 9999999/ 0 / 1]</p> <p>The L: counter counts the number of pages stored from within the document server mode screen at the operation panel, and with the Store File button from within the Copy mode screen</p>
8 212	C:Scan PGS/LS	*CTL	
8 213	F:Scan PGS/LS	*CTL	
8 215	S:Scan PGS/LS	*CTL	
8 216	L:Scan PGS/LS	*CTL	

- Reading user stamp data is not counted.
- If a job is cancelled, the pages output as far as the cancellation are counted.
- If the scanner application scans and stores 3 B5 sheets and 1 A4 sheet, the S: count is 4.
- If pages are copied but not stored on the document server, these counters do not change.
- If both sides of 3 A4 sheets are copied and stored to the document server, the C: count is 6 and the L: count is 6.
- If you enter document server mode then scan 6 pages, the L: count is 6.

System SP8-xxx: 2

SP8-xxx: Data Log2

8 221	ADF Org Feeds	*CTL	[0 to 9999999/ 0 / 1]
	These SPs count the number of pages fed through the ADF for front and back side scanning.		
8 221 1	Front	<p>Number of front sides fed for scanning:</p> <p>With an ADF that can scan both sides simultaneously, the Front side count is the same as the number of pages fed for either simplex or duplex scanning.</p> <p>With an ADF that cannot scan both sides simultaneously, the Front side count is the same as the number of pages fed for duplex front side scanning. (The front side is determined by which side the user loads face up.)</p>	
8 221 2	Back	<p>Number of rear sides fed for scanning:</p> <p>With an ADF that can scan both sides simultaneously, the Back count is the same as the number of pages fed for duplex scanning.</p> <p>With an ADF that cannot scan both sides simultaneously, the Back count is the same as the number of pages fed for duplex rear-side scanning.</p>	

- When 1 sheet is fed for duplex scanning the Front count is 1 and the Back count is 1.
- If a jam occurs during the job, recovery processing is not counted to avoid double counting. Also, the pages are not counted if the jam occurs before the first sheet is output.

8 231	Scan PGS/Mode	*CTL	[0 to 9999999/ 0 / 1]
	These SPs count the number of pages scanned by each ADF mode to determine the work load on the ADF.		
8 231 1	Large Volume	Selectable. Large copy jobs that cannot be loaded in the ADF at one time.	
8 231 2	SADF	Selectable. Feeding pages one by one through the ADF.	
8 231 3	Mixed Size	Selectable. Select "Mixed Sizes" on the operation panel.	
8 231 4	Custom Size	Selectable. Originals of non-standard size.	

8 231 5	Platen	Book mode. Raising the ADF and placing the original directly on the platen.
8 231 6	Mixed 1side/ 2side	Simplex and Duplex mode.

- If the scan mode is changed during the job, for example, if the user switches from ADF to Platen mode, the count is done for the last selected mode.
- The user cannot select mixed sizes or non-standard sizes with the fax application so if the original's page sizes are mixed or non-standard, these are not counted.
- If the user selects "Mixed Sizes" for copying in the platen mode, the Mixed Size count is enabled.
- In the SADF mode if the user copies 1 page in platen mode and then copies 2 pages with SADF, the Platen count is 1 and the SADF count is 3.

5

8 241	T:Scan PGS/Org	*CTL	[0 to 9999999/ 0 / 1]		
	These SPs count the total number of scanned pages by original type for all jobs, regardless of which application was used.				
8 242	C:Scan PGS/Org	*CTL	[0 to 9999999/ 0 / 1]		
	These SPs count the number of pages scanned by original type for Copy jobs.				
8 243	F:Scan PGS/Org	*CTL	[0 to 9999999/ 0 / 1]		
	These SPs count the number of pages scanned by original type for Fax jobs.				
8 245	S:Scan PGS/Org	*CTL	[0 to 9999999/ 0 / 1]		
	These SPs count the number of pages scanned by original type for Scan jobs.				
8 246	L:Scan PGS/Org	*CTL	[0 to 9999999/ 0 / 1]		
	These SPs count the number of pages scanned and stored from within the document server mode screen at the operation panel, and with the Store File button from within the Copy mode screen				
	8 241	8 242	8 243	8 245	8 246
8 24x 1: Text	Yes	Yes	Yes	Yes	Yes
8 24x 2: Text/Photo	Yes	Yes	Yes	Yes	Yes
8 24x 3: Photo	Yes	Yes	Yes	Yes	Yes
8 24x 4: GenCopy, Pale	Yes	Yes	No	Yes	Yes
8 24x 5: Map	Yes	Yes	No	Yes	Yes

8 24x 6: Normal/Detail	Yes	No	Yes	No	No
8 24x 7: Fine/Super Fine	Yes	No	Yes	No	No
8 24x 8: Binary	Yes	No	No	Yes	No
8 24x 9: Grayscale	Yes	No	No	Yes	No
8 24x 10: Color	Yes	No	No	Yes	No
8 24x 11: Other	Yes	Yes	Yes	Yes	Yes

- If the scan mode is changed during the job, for example, if the user switches from ADF to Platen mode, the count is done for the last selected mode.

8 251	T:Scan PGS/ImgEdt	*CTL	<p>These SPs show how many times Image Edit features have been selected at the operation panel for each application. Some examples of these editing features are:</p> <ul style="list-style-type: none"> • Erase> Border • Erase> Center • Image Repeat • Centering • Positive/Negative <p>[0 to 9999999 / 0 / 1]</p> <p>Note: The count totals the number of times the edit features have been used. A detailed breakdown of exactly which features have been used is not given.</p>
8 252	C:Scan PGS/ImgEdt	*CTL	
8 255	S : Scan PGS/ImgEdr	*CTL	
8 256	L:Scan PGS/ImgEdt	*CTL	
8 257	O:Scan PGS/ImgEdt	*CTL	

The L: counter counts the number of pages stored from within the document server mode screen at the operation panel, and with the Store File button from within the Copy mode screen.

8 261	T:Scan PGS/ColCr	*CTL	-
8 262	C:Scan PGS/ ColCr	*CTL	-
8 265	S:Scn PGS/ColCr	*CTL	-
8 266	L:Scn PGS/ColCr	*CTL	-

8 26x 1	Color Conversion	These SPs show how many times color creation features have been selected at the operation panel.
8 26x 2	Color Erase	
8 26x 3	Background	
8 26x 4	Other	

8 281	T:Scan PGS/TWAIN	*CTL	These SPs count the number of pages scanned using a TWAIN driver. These counters reveal how the TWAIN driver is used for delivery functions. [0 to 9999999/ 0 / 1] Note: At the present time, these counters perform identical counts.
8 285	S:Scan PGS/TWAIN	*CTL	

8 291	T:Scan PGS/Stamp	*CTL	These SPs count the number of pages stamped with the stamp in the ADF unit. [0 to 9999999/ 0 / 1] The L: counter counts the number of pages stored from within the document server mode screen at the operation panel, and with the Store File button from within the Copy mode screen
8 293	F:Scan PGS/Stamp	*CTL	
8 295	S:Scan PGS/Stamp	*CTL	

8 301	T:Scan PGS/Size	*CTL	[0 to 9999999/ 0 / 1]
	These SPs count by size the total number of pages scanned by all applications. Use these totals to compare original page size (scanning) and output (printing) page size [SP 8-441].		
8 302	C:Scan PGS/Size	*CTL	[0 to 9999999/ 0 / 1]
	These SPs count by size the total number of pages scanned by the Copy application. Use these totals to compare original page size (scanning) and output (printing) page size [SP 8-442].		
8 303	F:Scan PGS/Size	*CTL	[0 to 9999999/ 0 / 1]
	These SPs count by size the total number of pages scanned by the Fax application. Use these totals to compare original page size (scanning) and output page size [SP 8-443].		

8 305	S:Scan PGS/Size	*CTL	[0 to 9999999/ 0 / 1]
	These SPs count by size the total number of pages scanned by the Scan application. Use these totals to compare original page size (scanning) and output page size [SP 8-445].		
8 306	L:Scan PGS/Size	*CTL	[0 to 9999999/ 0 / 1]
	These SPs count by size the total number of pages scanned and stored from within the document server mode screen at the operation panel, and with the Store File button from within the Copy mode screen. Use these totals to compare original page size (scanning) and output page size [SP 8-446].		
8 30x 1	A3	-	
8 30x 2	A4		
8 30x 3	A5		
8 30x 4	B4		
8 30x 5	B5		
8 30x 6	DLT		
8 30x 7	LG		
8 30x 8	LT		
8 30x 9	HLT		
8 30x 10	Full Bleed		
8 30x 254	Other (Standard)		
8 30x 255	Other (Custom)		

8 311	T:Scan PGS/Rez	*CTL	[0 to 9999999/ 0 / 1]
	These SPs count by resolution setting the total number of pages scanned by applications that can specify resolution settings.		

	S: Scan PGS/Rez	*CTL	[0 to 9999999/ 0 / 1]
8 315	These SPs count by resolution setting the total number of pages scanned by applications that can specify resolution settings. Note: At the present time, SP8-311 and SP8-315 perform identical counts.		
8 31x 1	1200dpi <		
8 31x 2	600dpi to 1199dpi		
8 31x 3	400dpi to 599dpi		
8 31x 4	200dpi to 399dpi		
8 31x 5	< 199dpi		

5

- Copy resolution settings are fixed so they are not counted.
- The Fax application does not allow finely-adjusted resolution settings so no count is done for the Fax application.

8 381	T:Total PrtPGS	*CTL	These SPs count the number of pages printed by the customer. The counter for the application used for storing the pages increments. [0 to 9999999/ 0 / 1] The L: counter counts the number of pages stored from within the document server mode screen at the operation panel. Pages stored with the Store File button from within the Copy mode screen go to the C: counter.
8 382	C:Total PrtPGS	*CTL	
8 383	F:Total PrtPGS	*CTL	
8 384	P:Total PrtPGS	*CTL	
8 385	S:Total PrtPGS	*CTL	
8 386	L:Total PrtPGS	*CTL	
8 387	O:Total PrtPGS	*CTL	

- When several documents are merged for a print job, the number of pages stored are counted for the application that stored them.
- These counters are used primarily to calculate charges on use of the machine, so the following pages are not counted as printed pages:
 - Blank pages in a duplex printing job.
 - Blank pages inserted as document covers, chapter title sheets, and slip sheets.
 - Reports printed to confirm counts.
 - All reports done in the service mode (service summaries, engine maintenance reports, etc.)
 - Test prints for machine image adjustment.
 - Error notification reports.

- Partially printed pages as the result of a copier jam.

8 391	LSize PrtPGS	*CTL	[0 to 9999999/ 0 / 1]
	<p>These SPs count pages printed on paper sizes A3/DLT and larger.</p> <p>Note: In addition to being displayed in the SMC Report, these counters are also displayed in the User Tools display on the copy machine.</p>		

8 401	T:PrtPGS/LS	*CTL	<p>These SPs count the number of pages printed from the document server. The counter for the application used to print the pages is incremented.</p> <p>The L: counter counts the number of jobs stored from within the document server mode screen at the operation panel.</p> <p>[0 to 9999999/ 0 / 1]</p>
8 402	C:PrtPGS/LS	*CTL	
8 403	F:PrtPGS/LS	*CTL	
8 404	P:PrtPGS/LS	*CTL	
8 405	S:PrtPGS/LS	*CTL	
8 406	L:PrtPGS/LS	*CTL	

- Print jobs done with Web Image Monitor and Desk Top Binder are added to the L: count.
- Fax jobs done with Web Image Monitor and Desk Top Binder are added to the F: count.

8 411	Prints/Duplex	*CTL	<p>This SP counts the amount of paper (front/back counted as 1 page) used for duplex printing. Last pages printed only on one side are not counted.</p> <p>[0 to 9999999/ 0 / 1]</p>
-------	---------------	------	--

8 421	T:PrtPGS/Dup Comb	*CTL	[0 to 9999999/ 0 / 1]
	<p>These SPs count by binding and combine, and n-Up settings the number of pages processed for printing. This is the total for all applications.</p>		
8 422	C:PrtPGS/Dup Comb	*CTL	[0 to 9999999/ 0 / 1]
	<p>These SPs count by binding and combine, and n-Up settings the number of pages processed for printing by the copier application.</p>		
8 423	F:PrtPGS/Dup Comb	*CTL	[0 to 9999999/ 0 / 1]
	<p>These SPs count by binding and combine, and n-Up settings the number of pages processed for printing by the fax application.</p>		

8 424	P:PrtPGS/Dup Comb	*CTL	[0 to 99999999/ 0 / 1]
	These SPs count by binding and combine, and n-Up settings the number of pages processed for printing by the printer application.		
8 425	S:PrtPGS/Dup Comb	*CTL	[0 to 99999999/ 0 / 1]
	These SPs count by binding and combine, and n-Up settings the number of pages processed for printing by the scanner application.		
8 426	L:PrtPGS/Dup Comb	*CTL	[0 to 99999999/ 0 / 1]
	These SPs count by binding and combine, and n-Up settings the number of pages processed for printing from within the document server mode window at the operation panel.		
8 427	O:PrtPGS/Dup Comb	*CTL	[0 to 99999999/ 0 / 1]
	These SPs count by binding and combine, and n-Up settings the number of pages processed for printing by Other applications		
8 42x 1	Simplex> Duplex		
8 42x 2	Duplex> Duplex		
8 42x 3	Book> Duplex		
8 42x 4	Simplex Combine		
8 42x 5	Duplex Combine		
8 42x 6	2in1	2 pages on 1 side (2-Up)	
8 42x 7	4in1	4 pages on 1 side (4-Up)	
8 42x 8	6in1	6 pages on 1 side (6-Up)	
8 42x 9	8in1	8 pages on 1 side (8-Up)	
8 42x 10	9in1	9 pages on 1 side (9-Up)	
8 42x 11	16in1	16 pages on 1 side (16-Up)	
8 42x 12	Booklet		
8 42x 13	Magazine		
8 42x 14	2in1 + Booklet		
8 42x 15	4in1 + Booklet		

8 42x 16	6in1 + Booklet	
8 42x 17	8in1 + Booklet	
8 42x 18	9in1 + Booklet	
8 42x 19	2in1 + Magazine	
8 42x 20	4in1 + Magazine	
8 42x 21	6in1 + Magazine	
8 42x 22	8in1 + Magazine	
8 42x 23	9in1 + Magazine	
8 42x 24	16in1 + Magazine	

- These counts (SP8 421 to SP8 427) are especially useful for customers who need to improve their compliance with ISO standards for the reduction of paper consumption.
- Pages that are only partially printed with the n-Up functions are counted as 1 page.
- Here is a summary of how the counters work for Booklet and Magazine modes:

Booklet			Magazine	
Original Pages	Count		Original Pages	Count
1	1		1	1
2	2		2	2
3	2		3	2
4	2		4	2
5	3		5	4
6	4		6	4
7	4		7	4
8	4		8	4

8 431	T:PrtPGS/ImgEdt	*CTL	[0 to 9999999 / 0 / 1]
	These SPs count the total number of pages output with the three features below, regardless of which application was used.		

8 432	C:PrtPGS/ImgEdt	*CTL	[0 to 9999999/ 0 / 1]
	These SPs count the total number of pages output with the three features below with the copy application.		
8 434	P:PrtPGS/ImgEdt	*CTL	[0 to 9999999/ 0 / 1]
	These SPs count the total number of pages output with the three features below with the print application.		
8 436	L:PrtPGS/ImgEdt	*CTL	[0 to 9999999/ 0 / 1]
	These SPs count the total number of pages output from within the document server mode window at the operation panel with the three features below.		
8 437	O:PrtPGS/ImgEdt	*CTL	[0 to 9999999/ 0 / 1]
	These SPs count the total number of pages output with the three features below with Other applications.		
8 43x 1	Cover/Slip Sheet	Total number of covers or slip sheets inserted. The count for a cover printed on both sides counts 2.	
8 43x 2	Series/Book	The number of pages printed in series (one side) or printed as a book with booklet right/left pagination.	
8 43x 3	User Stamp	The number of pages printed where stamps were applied, including page numbering and date stamping.	

8 441	T:PrtPGS/Ppr Size	*CTL	[0 to 9999999/ 0 / 1]
	These SPs count by print paper size the number of pages printed by all applications.		
8 442	C:PrtPGS/Ppr Size	*CTL	[0 to 9999999/ 0 / 1]
	These SPs count by print paper size the number of pages printed by the copy application.		
8 443	F:PrtPGS/Ppr Size	*CTL	[0 to 9999999/ 0 / 1]
	These SPs count by print paper size the number of pages printed by the fax application.		
8 444	P:PrtPGS/Ppr Size	*CTL	[0 to 9999999/ 0 / 1]
	These SPs count by print paper size the number of pages printed by the printer application.		

8 445	S:PrtPGS/Ppr Size	*CTL	[0 to 9999999/ 0 / 1]
	These SPs count by print paper size the number of pages printed by the scanner application.		
8 446	L:PrtPGS/Ppr Size	*CTL	[0 to 9999999/ 0 / 1]
	These SPs count by print paper size the number of pages printed from within the document server mode window at the operation panel.		
8 447	O:PrtPGS/Ppr Size	*CTL	[0 to 9999999/ 0 / 1]
	These SPs count by print paper size the number of pages printed by Other applications.		
8 44x 1	A3		
8 44x 2	A4		
8 44x 3	A5		
8 44x 4	B4		
8 44x 5	B5		
8 44x 6	DLT		
8 44x 7	LG		
8 44x 8	LT		
8 44x 9	HLT		
8 44x 10	Full Bleed		
8 44x 254	Other (Standard)		
8 44x 255	Other (Custom)		

- These counters do not distinguish between LEF and SEF.

8 451	PrtPGS/Ppr Tray	*CTL	[0 to 9999999/ 0 / 1]
	These SPs count the number of sheets fed from each paper feed station.		
8 451 1	Bypass Tray	Bypass Tray	
8 451 2	Tray 1	Machine	

8 451 3	Tray 2	Paper Tray Unit (Option)
8 451 4	Tray 3	Paper Tray Unit (Option)
8 451 5	Tray 4	Paper Tray Unit (Option)
8 451 6	Tray 5	Not used
8 451 7	Tray 6	Not used
8 451 8	Tray 7	Not used
8 451 9	Tray 8	Not used
8 451 10	Tray 9	Not used
8 451 11	Tray10	Not used
8 451 12	Tray11	Not used
8 451 13	Tray12	Not used
8 451 14	Tray13	Not used
8 451 15	Tray14	Not used
8 451 16	Tray15	Not used

8 461	T:PrtPGS/Ppr Type	*CTL	[0 to 9999999/ 0 / 1]
	<p>These SPs count by paper type the number pages printed by all applications.</p> <ul style="list-style-type: none"> • These counters are not the same as the PM counter. The PM counter is based on feed timing to accurately measure the service life of the feed rollers. However, these counts are based on output timing. • Blank sheets (covers, chapter covers, slip sheets) are also counted. • During duplex printing, pages printed on both sides count as 1, and a page printed on one side counts as 1. 		
8 462	C:PrtPGS/Ppr Type	*CTL	[0 to 9999999/ 0 / 1]
	<p>These SPs count by paper type the number pages printed by the copy application.</p>		
8 463	F:PrtPGS/Ppr Type	*CTL	[0 to 9999999/ 0 / 1]
	<p>These SPs count by paper type the number pages printed by the fax application.</p>		

8 464	P:PrtPGS/Ppr Type	*CTL	[0 to 9999999/ 0 / 1]
	These SPs count by paper type the number pages printed by the printer application.		
8 466	L:PrtPGS/Ppr Type	*CTL	[0 to 9999999/ 0 / 1]
	These SPs count by paper type the number pages printed from within the document server mode window at the operation panel.		
8 46x 1	Normal		
8 46x 2	Recycled		
8 46x 3	Special		
8 46x 4	Thick		
8 46x 5	Normal (Back)		
8 46x 6	Thick (Back)		
8 46x 7	OHP		
8 46x 8	Other		

8 471	PrtPGS/Mag	*CTL	[0 to 9999999/ 0 / 1]
	These SPs count by magnification rate the number of pages printed.		
8 471 1	< 49%		
8 471 2	50% to 99%		
8 471 3	100%		
8 471 4	101% to 200%		
8 471 5	201% <		

- Counts are done for magnification adjusted for pages, not only on the operation panel but performed remotely with an external network application capable of performing magnification adjustment as well.
- Magnification adjustments done with printer drivers with PC applications such as Excel are also counted.
- Magnification adjustments done for adjustments after they have been stored on the document server are not counted.

- Magnification adjustments performed automatically during Auto Reduce/Enlarge copying are counted.
- The magnification rates of blank cover sheets, slip sheets, etc. are automatically assigned a rate of 100%.

8 481	T:PrtPGS/TonSave	*CTL	
8 484	P:PrtPGS/TonSave	*CTL	
<p>These SPs count the number of pages printed with the Toner Save feature switched on.</p> <p>Note: These SPs return the same results as this SP is limited to the Print application.</p> <p>[0 to 99999999 / 0 / 1]</p>			

5

8 491	T:PrtPGS/Col Mode	*CTL	These SPs count the number of pages printed in the Color Mode by each application.
8 492	C:PrtPGS/Col Mode	*CTL	
8 493	F:PrtPGS/Col Mode	*CTL	
8 496	L:PrtPGS/Col Mode	*CTL	
8 497	O:PrtPGS/Col Mode	*CTL	
8 49x 1	B/W		
8 49x 2	Single Color		
8 49x 3	Two Color		
8 49x 4	Full Color		

8 501	T:PrtPGS/Col Mode	*CTL	These SPs count the number of pages printed in the Color Mode by the print application.
8 504	P:PrtPGS/Col Mode	*CTL	
8 507	O:PrtPGS/Col Mode	*CTL	
8 50x 1	B/W		
8 50x 2	Mono Color		
8 50x 3	Full Color		
8 50x 4	Single Color		

8 50x 5	Two Color			
8 511	T:PrfPGS/Emul	*CTL	[0 to 9999999/ 0 / 1]	
	These SPs count by printer emulation mode the total number of pages printed.			
8 514	P:PrfPGS/Emul	*CTL	[0 to 9999999/ 0 / 1]	
	These SPs count by printer emulation mode the total number of pages printed.			
8 514 1	RPCS			
8 514 2	RPDL			
8 514 3	PS3			
8 514 4	R98			
8 514 5	R16			
8 514 6	GL/GL2			
8 514 7	R55			
8 514 8	RTIFF			
8 514 9	PDF			
8 514 10	PCL5e/5c			
8 514 11	PCL XL			
8 514 12	IPDL-C			
8 514 13	BM-Links			Japan Only
8 514 14	Other			
8 514 15	IPDS			
8 514 16	XPS			

- SP8 511 and SP8 514 return the same results as they are both limited to the Print application.
- Print jobs output to the document server are not counted.

8 521	T:PrtPGS/FIN	*CTL	[0 to 9999999 / 0 / 1]
	These SPs count by finishing mode the total number of pages printed by all applications.		
8 522	C:PrtPGS/FIN	*CTL	[0 to 9999999 / 0 / 1]
	These SPs count by finishing mode the total number of pages printed by the Copy application.		
8 523	F:PrtPGS/FIN	*CTL	[0 to 9999999 / 0 / 1]
	These SPs count by finishing mode the total number of pages printed by the Fax application. NOTE: Print finishing options for received faxes are currently not available.		
8 524	P:PrtPGS/FIN	*CTL	[0 to 9999999 / 0 / 1]
	These SPs count by finishing mode the total number of pages printed by the Print application.		
8 525	S:PrtPGS/FIN	*CTL	[0 to 9999999 / 0 / 1]
	These SPs count by finishing mode the total number of pages printed by the Scanner application.		
8 526	L:PrtPGS/FIN	*CTL	[0 to 9999999 / 0 / 1]
	These SPs count by finishing mode the total number of pages printed from within the document server mode window at the operation panel.		
8 52x 1	Sort		
8 52x 2	Stack		
8 52x 3	Staple		
8 52x 4	Booklet		
8 52x 5	Z-Fold		
8 52x 6	Punch		
8 52x 7	Other		
8 52x 8	Inside-Fold		
8 52x 9	Three-IN-Fold		

8 52x 10	Three-OUT-Fold
8 52x 11	Four-Fold
8 52x 12	KANNON-Fold
8 52x 13	Perfect-Bind
8 52x 14	Ring-Bind

Note

- If stapling is selected for finishing and the stack is too large for stapling, the unstapled pages are still counted.
- The counts for staple finishing are based on output to the staple tray, so jam recoveries are counted.

System SP8-xxx: 3

SP8-xxx: Data Log2

8 531	Staples	*CTL	This SP counts the amount of staples used by the machine. [0 to 9999999 / 0 / 1]
-------	---------	------	---

8 551	T:PrtBooks/FIN	*CTL	Not used
8 551 1	Perfect-Bind		
8 551 2	Ring-Bind		

8 552	C:PrtBooks/FIN	*CTL	Not used
8 552 1	Perfect-Bind		
8 552 2	Ring-Bind		

8 554	T:PrtBooks/FIN	*CTL	Not used
8 554 1	Perfect-Bind		
8 554 2	Ring-Bind		

8 556	L:PrtBooks/FIN	*CTL	Not used
8 552 6	Perfect-Bind		
8 552 6	Ring-Bind		

8561	[T: A Sheet of Paper]		
8562	[C: A Sheet of Paper]		
8563	[F: A Sheet of Paper]		
8564	[P: A Sheet of Paper]		
8566	[L: A Sheet of Paper]		

8567	[O: A Sheet of Paper]
------	-----------------------

8 581	T:Counter	*CTL	[0 to 9999999 / 0 / 1]
	These SPs count the total output broken down by color output, regardless of the application used. In addition to being displayed in the SMC Report, these counters are also displayed in the User Tools display on the copy machine.		
8 581 1	Total		
8 581 2	Total: Full Color		
8 581 3	B&W/Single Color		
8 581 4	Development: CMY		
8 581 5	Development: K		
8 581 6	Copy: Color		
8 581 7	Copy: B/W		
8 581 8	Print: Color		
8 581 9	Print: B/W		
8 581 10	Total: Color		
8 581 11	Total: B/W		
8 581 12	Full Color: A3		
8 581 13	Full Color: B4 JIS or Smaller		
8 581 14	Full Color Print		
8 581 15	Mono Color Print		
8 581 16	Full Color GPC		
8 581 17	Twin Colour Mode Print		
8 581 18	Full Colour Print (Twin)		
8 581 19	Mono Colour Print (Twin)		
8 581 20	Full Colour Total (CV)		
8 581 21	Mono Colour Total (CV)		

8 581 22	Full Colour Print (CV)
8 581 28	Development: CMY (A3)
8 581 29	Development: K (A3)
8 581 30	Total: Color (A3)
8 581 31	Total: B/W (A3)

8 582	C:Counter	*CTL	[0 to 99999999 / 0 / 1]
	These SPs count the total output of the copy application broken down by color output.		
8 582 1	B/W		
8 582 2	Single Color		
8 582 3	Two Color		
8 582 4	Full Color		

8 583	F:Counter	*CTL	[0 to 99999999 / 0 / 1]
	These SPs count the total output of the fax application broken down by color output.		
8 583 1	B/W		
8 583 2	Single Color		

8 584	P:Counter	*CTL	[0 to 99999999 / 0 / 1]
	These SPs count the total output of the print application broken down by color output.		
8 584 1	B/W		
8 584 2	Mono Color		
8 584 3	Full Color		
8 584 4	Single Color		
8 584 5	Two Color		

8 586	L:Counter	*CTL	[0 to 99999999 / 0 / 1]
-------	-----------	------	-------------------------

	These SPs count the total output of the local storage broken down by color output.
8 582 1	B/W
8 582 2	Single Color
8 582 3	Two Color
8 582 4	Full Color

8 591	O:Counter	*CTL	[0 to 9999999/ 0 / 1]
	These SPs count the totals for A3/DLT paper use, number of duplex pages printed, and the number of staples used. These totals are for Other (O:) applications only.		
8 591 1	A3/DLT	-	
8 591 2	Duplex		

8 601	[T: Coverage Counter]	*CTL	[0 to 9999999/ 0 / 1]
8 602	[C: Coverage Counter]	*CTL	[0 to 9999999/ 0 / 1]
8 603	[F: Coverage Counter]	*CTL	[0 to 9999999/ 0 / 1]
8 604	[P: Coverage Counter]	*CTL	[0 to 9999999/ 0 / 1]
8 606	[L: Coverage Counter]	*CTL	[0 to 9999999/ 0 / 1]
	These SPs count the total coverage for each color and the total printout pages for each printing mode.		
8 60x 1	B/W	-	
8 60x 2	Color		
8 60x 11	B/W Printing Pages		
8 60x 12	Color Printing Pages		
8 60x 21	Coverage Counter 1		
8 60x 22	Coverage Counter 2		
8 60x 23	Coverage Counter 3		

8 60x 31	Coverage Counter 1 (YMC)	-
8 60x 32	Coverage Counter 2 (YMC)	
8 60x 33	Coverage Counter 3 (YMC)	

8 617	SDK Apli Counter	*CTL	[0 to 9999999/ 0 / 1]
	These SPs count the total printout pages for each SDK applicaion.		
8 617 1 to 012	SDK-1 to -12	-	

8 621	Func Use Counter	*CTL	-
001 to 064	Function-001 to Function-064		

8 631	T:FAX TX PGS	*CTL	[0 to 9999999/ 0 / 1]
	These SPs count by color mode the number of pages sent by fax to a telephone number.		
8 633	F:FAX TX PGS	*CTL	[0 to 9999999/ 0 / 1]
	These SPs count by color mode the number of pages sent by fax to a telephone number.		
8 63x 1	B/W		
8 63x 2	Color		

- If a document has color and black-and-white pages mixed, the pages are counted separately as B/W or Color.
- At the present time, this feature is provided for the Fax application only so SP8631 and SP8633 are the same.
- The counts include error pages.
- If a document is sent to more than one destination with a Group transmission, the count is done for each destination.
- Polling transmissions are counted but polling RX are not.

- Relay, memory, and confidential mailbox transmissions and are counted for each destination.

8 641	T:IFAX TX PGS	*CTL	[0 to 9999999/ 0 / 1]
	These SPs count by color mode the number of pages sent by fax to as fax images using I-Fax.		
8 643	F:IFAX TX PGS	*CTL	[0 to 9999999/ 0 / 1]
	These SPs count by color mode the number of pages sent by Fax as fax images using I-Fax.		
8 64x 1	B/W		
8 64x 2	Color		

- If a document has color and black-and-white pages mixed, the pages are counted separately as B/W or Color.
- At the present time, this feature is provided for the Fax application only so SP8641 and SP8643 are the same.
- The counts include error pages.
- If a document is sent to more than one destination with a Group transmission, the count is done for each destination.
- Polling transmissions are counted but polling RX are not.
- Relay, memory, and confidential mailbox transmissions and are counted for each destination.

8 651	T:S-to-Email PGS	*CTL	[0 to 9999999/ 0 / 1]
	These SPs count by color mode the total number of pages attached to an e-mail for both the Scan and document server applications.		
8 655	S:S-to-Email PGS	*CTL	[0 to 9999999/ 0 / 1]
	These SPs count by color mode the total number of pages attached to an e-mail for the Scan application only.		
8 65x 1	B/W		
8 65x 2	Color		

↓ Note

- The count for B/W and Color pages is done after the document is stored on the HDD. If the job is cancelled before it is stored, the pages are not counted.

- If Scan-to-Email is used to send a 10-page document to 5 addresses, the count is 10 (the pages are sent to the same SMTP server together).
- If Scan-to-PC is used to send a 10-page document to 5 folders, the count is 50 (the document is sent to each destination of the SMB/FTP server).
- Due to restrictions on some devices, if Scan-to-Email is used to send a 10-page document to a large number of destinations, the count may be divided and counted separately. For example, if a 10-page document is sent to 200 addresses, the count is 10 for the first 100 destinations and the count is also 10 for the second 100 destinations, for a total of 20).

8 661	T:Deliv PGS/Svr	*CTL	[0 to 99999999 / 0 / 1]
	These SPs count by color mode the total number of pages sent to a Scan Router server by both Scan and LS applications.		
8 665	S:Deliv PGS/Svr	*CTL	[0 to 99999999 / 0 / 1]
	These SPs count by color mode the total number of pages sent to a Scan Router server by the Scan application.		
8 66x 1	B/W		
8 66x 2	Color		

Note

- The B/W and Color counts are done after the document is stored on the HDD of the Scan Router server.
- If the job is canceled before storage on the Scan Router server finishes, the counts are not done.
- The count is executed even if regardless of confirmation of the arrival at the Scan Router server.

8 671	T:Deliv PGS/PC	*CTL	[0 to 99999999 / 0 / 1]
	These SPs count by color mode the total number of pages sent to a folder on a PC (Scan-to-PC) with the Scan and LS applications.		
8 675	S: Deliv PGS/PC	*CTL	[0 to 99999999 / 0 / 1]
	These SPs count by color mode the total number of pages sent with Scan-to-PC with the Scan application.		
8 67x 1	B/W		
8 67x 2	Color		

8 681	T:PCFAX TXPGS	*CTL	These SPs count the number of pages sent by PC Fax. These SPs are provided for the Fax application only, so the counts for SP8 681 and SP8 683 are the same. [0 to 9999999/ 0 / 1]
8 683	F:PCFAX TXPGS	*CTL	

- This counts pages sent from a PC using a PC fax application, from the PC through the copier to the destination.
- When sending the same message to more than one place using broadcasting, the pages are only counted once. (For example, a 10-page fax is sent to location A and location B. The counter goes up by 10, not 20.)

8 691	T:TX PGS/LS	*CTL	These SPs count the number of pages sent from the document server. The counter for the application that was used to store the pages is incremented. [0 to 9999999/ 0 / 1] The L: counter counts the number of pages stored from within the document server mode screen at the operation panel. Pages stored with the Store File button from within the Copy mode screen go to the C: counter.
8 692	C:TX PGS/LS	*CTL	
8 693	F:TX PGS/LS	*CTL	
8 694	P:TX PGS/LS	*CTL	
8 695	S:TX PGS/LS	*CTL	
8 696	L:TX PGS/LS	*CTL	

↓ Note

- Print jobs done with Web Image Monitor and Desk Top Binder are added to the count.
- If several documents are merged for sending, the number of pages stored are counted for the application that stored them.
- When several documents are sent by a Fax broadcast, the F: count is done for the number of pages sent to each destination.

	TX PGS/Port	*CTL	[0 to 9999999/ 0 / 1]
8 701	These SPs count the number of pages sent by the physical port used to send them. For example, if a 3-page original is sent to 4 destinations via ISDN G4, the count for ISDN (G3, G4) is 12.		
8 701 1	PSTN-1		
8 701 2	PSTN-2		
8 701 3	PSTN-3		
8 701 4	ISDN (G3,G4)		

8 701 5	Network	
---------	---------	--

8 711	T:Scan PGS/Comp	*CTL	[0 to 99999999 / 0 / 1]
8 715	S:Scan PGS/Comp	*CTL	[0 to 99999999 / 0 / 1]
	These SPs count the number of pages sent by each compression mode.		
8 71x 1	JPEG/JPEG2000		
8 71x 2	TIFF(Multi/Single)		
8 71x 3	PDF		
8 71x 4	Other		
8 71x 5	PDF/Comp		
8 71x 6	PDF/A		
8 71x 7	PDF (OCR)		
8 71x 8	PDF/Comp (OCR)		
8 71x 9	PDF/A (OCR)		

8 721	T:Deliv PGS/WSD/DSM	*CTL	[0 to 99999999 / 0 / 1]
8 725	S: Deliv PGS/WSD/DSM	*CTL	
	These SPs count the number of pages scanned by each scanner mode.		
x 1	B/W	-	
x 2	Color	-	

8 731	T:Scan PGS/Media	*CTL	[0 to 99999999 / 0 / 1]
8 735	S:Scan PGS/Media	*CTL	
	These SPs count the number of pages scanned and saved in a meia by each scanner mode.		
x 1	B/W	-	
x 2	Color	-	

8 741	RX PGS/Port	*CTL	[0 to 9999999/ 0 / 1]
	These SPs count the number of pages received by the physical port used to receive them.		
8 741 1	PSTN-1	-	
8 741 2	PSTN-2	-	
8 741 3	PSTN-3	-	
8 741 4	ISDN (G3,G4)	-	
8 741 5	Network	-	

8 771	Dev Counter	*CTL	[0 to 9999999/ 0 / 1]
	These SPs count the frequency of use (number of rotations of the development rollers) for black and other color toners.		
8 771 1	Total		
8 771 2	K		
8 771 3	Y		
8 771 4	M		
8 771 5	C		

8 781	Toner_Bottle_Info.	*ENG	[0 to 9999999/ 0 / 1]
	These SPs display the number of already replaced toner bottles. NOTE: Currently, the data in SP7-833-011 through 014 and the data in SP8-781-001 through 004 are the same.		
8 781 1	Toner: BK	The number of black-toner bottles	
8 781 2	Toner: Y	The number of yellow-toner bottles	
8 781 3	Toner: M	The number of magenta-toner bottles	
8 781 4	Toner: C	The number of cyan-toner bottles	

8 791	LS Memory Remain	*CTL	This SP displays the percent of space available on the document server for storing documents. [0 to 100 / 0 / 1]
-------	------------------	------	---

8 801	Toner Remain	*CTL	[0 to 100/ 0 / 1]
	These SPs display the percent of toner remaining for each color. This SP allows the user to check the toner supply at any time. Note: This precise method of measuring remaining toner supply (1% steps) is better than other machines in the market that can only measure in increments of 10 (10% steps).		
	8 801 1	K	
	8 801 2	Y	
	8 801 3	M	
8 801 4	C		

5

8811	Eco Counter		
	-		
001	Eco Total	*CTL	[0 to 99999999 / 0 / 1 / step]
002	Color	*CTL	
003	Full Color	*CTL	
004	Duplex	*CTL	
005	Combine	*CTL	
006	Color (%)	*CTL	[0 to 100 / 0 / 1% / step]
007	Full Color (%)	*CTL	
008	Duplex (%)	*CTL	
009	Combine (%)	*CTL	
010	Paper Cut (%)	*CTL	

101	Eco Totalr>Last	*CTL	[0 to 99999999 / 0 / 1 / step]
102	Color>Last	*CTL	
103	Full Color>Last	*CTL	
104	Duplex>Last	*CTL	
105	Combine>Last	*CTL	
106	Color(%):Last	*CTL	[0 to 100 / 0 / 1% / step]
107	Full Color (%):Last	*CTL	
108	Duplex (%):Last	*CTL	
109	Combine (%):Last	*CTL	
110	Paper Cut (%):Last	*CTL	

8 851	CVr Cnt: 0-10%	*ENG	[0 to 99999999 / 0 / 1]
	These SPs display the number of scanned sheets on which the coverage of each color is from 0% to 10%.		
8 851 11	0 to 2%: BK	8 851 31	5 to 7%: BK
8 851 12	0 to 2%: Y	8 851 32	5 to 7%: Y
8 851 13	0 to 2%: M	8 851 33	5 to 7%: M
8 851 14	0 to 2%: C	8 851 34	5 to 7%: C
8 851 21	3 to 4%: BK	8 851 41	8 to 10%: BK
8 851 22	3 to 4%: Y	8 851 42	8 to 10%: Y
8 851 23	3 to 4%: M	8 851 43	8 to 10%: M
8 851 24	3 to 4%: C	8 851 44	8 to 10%: C

8 861	CVr Cnt: 11-20%	*ENG	[0 to 99999999 / 0 / 1]
	These SPs display the number of scanned sheets on which the coverage of each color is from 11% to 20%.		
8 861 1	BK		

8 861 2	Y
8 861 3	M
8 861 4	C

8 871	CVr Cnt: 21-30%	*ENG	[0 to 9999999/ 0 / 1]
	These SPs display the number of scanned sheets on which the coverage of each color is from 21% to 30%.		
8 871 1	BK		
8 871 2	Y		
8 871 3	M		
8 871 4	C		

8 881	CVr Cnt: 31%-	*ENG	[0 to 9999999/ 0 / 1]
	These SPs display the number of scanned sheets on which the coverage of each color is 31% or higher.		
8 881 1	BK		
8 881 2	Y		
8 881 3	M		
8 881 4	C		

8 891	Page/Toner Bottle	*ENG	[0 to 9999999/ 0 / 1]
	These SPs display the amount of the remaining current toner for each color.		
8 891 1	BK		
8 891 2	Y		
8 891 3	M		
8 891 4	C		

8 901	Page/Toner_Prev1	*ENG	[0 to 9999999/ 0 / 1]
	These SPs display the amount of the remaining previous toner for each color.		
8 901 1	BK		
8 901 2	Y		
8 901 3	M		
8 901 4	C		

8 911	Page/Toner_Prev2	*ENG	[0 to 9999999/ 0 / 1]
	These SPs display the amount of the remaining 2nd previous toner for each color.		
8 911 1	BK		
8 911 2	Y		
8 911 3	M		
8 911 4	C		

8 921	Cvr Cnt/Total	*CTL	[0 to 9999999/ 0 / 1]
	Displays the total coverage and total printout number for each color.		
8 921 1	Coverage (%) Bk		
8 921 2	Coverage (%) Y		
8 921 3	Coverage (%) M		
8 921 4	Coverage (%) C		
8 921 11	Coverage /P: Bk		
8 921 12	Coverage /P: Y		
8 921 13	Coverage /P: M		
8 921 14	Coverage /P: C		

8 941	Machine Status	*CTL	[0 to 99999999/ 0 / 1]
	These SPs count the amount of time the machine spends in each operation mode. These SPs are useful for customers who need to investigate machine operation for improvement in their compliance with ISO Standards.		
8 941 1	Operation Time	Engine operation time. Does not include time while controller is saving data to HDD (while engine is not operating).	
8 941 2	Standby Time	Engine not operating. Includes time while controller saves data to HDD. Does not include time spent in Energy Save, Low Power, or Off modes.	
8 941 3	Energy Save Time	Includes time while the machine is performing background printing.	
8 941 4	Low Power Time	Includes time in Energy Save mode with Engine on. Includes time while machine is performing background printing.	
8 941 5	Off Mode Time	Includes time while machine is performing background printing. Does not include time machine remains powered off with the power switches.	
8 941 6	SC	Total time when SC errors have been staying.	
8 941 7	PrtJam	Total time when paper jams have been staying during printing.	
8 941 8	OrgJam	Total time when original jams have been staying during scanning.	
8 941 9	Supply PM Unit End	Total time when toner end has been staying	
8 951	AddBook Register	*CTL	
	These SPs count the number of events when the machine manages data registration.		

8 951 1	User Code/User ID	User code registrations.	[0 to 9999999 / 0 / 1]
8 951 2	Mail Address	Mail address registrations.	
8 951 3	Fax Destination	Fax destination registrations.	
8 951 4	Group	Group destination registrations.	
8 951 5	Transfer Request	Fax relay destination registrations for relay TX.	
8 951 6	F-Code	F-Code box registrations.	
8 951 7	Copy Program	Copy application registrations with the Program (job settings) feature.	[0 to 255 / 0 / 255]
8 951 8	Fax Program	Fax application registrations with the Program (job settings) feature.	
8 951 9	Printer Program	Printer application registrations with the Program (job settings) feature.	
8 951 10	Scanner Program	Scanner application registrations with the Program (job settings) feature.	

5

8961	Electricity Status	
	-	
001	Ctrl Standby Time	[0 to 99999999 / 0 / 1/step]
002	STR Time	
003	Main Power Off Time	
004	Reading and Printing Time	

-005	Printing Time	[0 to 99999999 / 0 / 1/step]
006	Reading Time	
007	Eng Waiting Time	
008	Low Power State Time	
009	Silent State Time	
010	Heater Off State Time	
011	LCD on Time	

8971	Unit Control	[0 to 99999999 / 0 / 1/step]
	-	
001	Engine Off Recovery Count	
002	Power Off Count	
003	Force Power Off Count	

8 999	Admin. Counter List	*CTL	[0 to 99999999/ 0 / 1]
	Displays the total coverage and total printout number for each color.		
8 999 1	Total		
8 999 2	Copy: Full Color		
8 999 3	Copy: BW		
8 999 4	Copy: Single Color		
8 999 5	Copy: Two Color		
8 999 6	Printer Full Color		
8 999 7	Printer BW		
8 999 8	Printer Single Color		
8 999 9	Printer Two Color		
8 999 10	Fax Print: BW		
8 999 11	Fax Print: Single Color		

8 999 12	A3/DLT	
8 999 13	Duplex	
8 999 22	Copy: Full Color (%)	
8 999 23	Copy: BW (%)	
8 999 24	Copy: Single Color (%)	
8 999 25	Copy: Two Color (%)	
8 999 26	Printer: Full Color (%)	
8 999 27	Printer: BW (%)	
8 999 28	Printer: Single Color (%)	
8 999 29	Printer: Two Color (%)	
8 999 30	Fax: BW (%)	
8 999 31	Fax: Single Color (%)	
8 999 101	Transmission Total: Color	
8 999 102	Transmission Total: BW	
8 999 103	FAX Transmission	
8 999 104	Scanner Transmission: Color	
8 999 105	Scanner Transmission: BW	

Input and Output Check

Input Check Table

When entering the Input Check mode, 8 digits display the result for a section. Each digit corresponds to a different device as shown in the table.

Bit No.	7	6	5	4	3	2	1	0
Result	0 or 1	0 or 1	0 or 1	0 or 1	0 or 1	0 or 1	0 or 1	0 or 1

Printer

5

5803	Description	Reading	
		0	1
5803 1	1 Tray Size	See table 1 following this table.	
5803 2	1 Tray Paper Height Sensor 1	See table 2 following this table.	
5803 3	1 Tray Paper Height Sensor 2	See table 2 following this table.	
5803 4	1 Tray Paper End Sensor	No paper	Paper remaining
5803 5	1 Tray Paper Lift Sensor	Not upper limit	Upper limit
5803 6	Bypass Paper End Sensor	No paper	Paper remaining
5803 7	Paper Feed Sensor	Paper detected	Paper not detected
5803 8	Paper Exit Sensor	Paper detected	Paper not detected
5803 9	Paper Exit Full Sensor	Paper not full	Paper full
5803 10	Fusing Exit Sensor	Paper not detected	Paper detected
5803 11	Fusing Entrance Sensor	Paper detected	Paper not detected
5803 12	Inverter Sensor	Paper detected	Paper not detected
5803 13	Duplex Entrance Sensor	Paper detected	Paper not detected
5803 14	Duplex Exit Sensor	Paper detected	Paper not detected
5803 15	Registration Sensor	Paper detected	Paper not detected

5803 16	Vertical Transport Sensor	Paper detected	Paper not detected
5803 17	Bypass Paper Size Sensor	Paper detected	Paper not detected
5803 18	Toner End Sensor: Y	Toner end	Toner remaining
5803 19	Toner End Sensor: C	Toner end	Toner remaining
5803 20	Toner End Sensor: M	Toner end	Toner remaining
5803 21	Toner End Sensor: K	Toner end	Toner remaining
5803 22	Drum Phase Sensor: K	Actuator not detected	Actuator detected
5803 23	Drum Phase Sensor: CMY	Actuator not detected	Actuator detected
5803 24	Interlock SW 1	Front door open	Front door closed
5803 25	Interlock SW 2	Front door open	Front door closed
5803 26	Right Door Sensor	Closed	Open
5803 30	Duplex Cover Sensor	Closed	Open
5803 31	LDU Shutter Sensor	Closed	Open
5803 32	Waste Toner Bottle Set Sensor	Set	Not set
5803 33	Waste Toner Bottle Full Sensor	Not full	Full
5803 34	ITB Unit: New	Not new	New
5803 35	Fusing Fan: Lock	Normal	Lock
5803 36	Fusing Fan 1: Lock	Normal	Lock
5803 37	Fusing Fan 2: Lock	Normal	Lock
5803 38	Fusing Front Fan: Lock	Normal	Lock
5803 40	Toner Supply Fan: Lock	Normal	Lock
5803 41	Drive Unit Fan: Lock	Normal	Lock
5803 43	Ventilation Fan 1: Lock	Normal	Lock
5803 44	Ventilation Fan 2: Lock	Normal	Lock

5803 45	Development Fan: Lock	Normal	Lock
5803 46	Laser Unit Fan: Lock	Normal	Lock
5803 47	Feed Fan: Lock	Normal	Lock
5803 48	Transfer Belt Contact Sensor	Not contact	Contact
5803 49	Paper Transfer Roller Contact Sensor	Not contact	Contact
5803 50	Drum Motor: K: Lock	Normal	Lock
5803 51	Fusing Motor: Lock	Normal	Lock
5803 52	Development Motor:CMY: Lock	Normal	Lock
5803 53	Drum Motor:CMY: Lock	Normal	Lock
5803 54	PP: D: SC	SC detected	No SC
5803 55	PP: CB: SC	SC detected	No SC
5803 56	PP: T1T2: SC	SC detected	No SC
5803 57	Fusing: Generation	Not detected	Detected
5803 58	Fusing: New	New	Not new
5803 59	Fusing: Destination	Set	Not set
5803 60	Fusing: Set	Set	Not set
5803 61	Zero-cross Signal	Not detected	Detected
5803 62	Fusing: Temperature	Detected	Not detected
5803 63	1-Bin: Set	Set	Not set
5803 64	1-Bin: Paper Sensor	Paper detected	Paper not detected
5803 65	1-Bin: Exit Sensor	Paper detected	Paper not detected
5803 66	Side Tray: Set	Set	Not set
5803 67	Upper Cover Sensor	Closed	Open
5803 68	Key Card: Set	Set	Not set
5803 69	Mechanical Counter: K: Set	Set	Not set

5803 70	Mechanical Counter: CMY: Set	Set	Not set
5803 71	Key Counter: Set	Set	Not set
5803 72	BCU Version	-	-
5803 77	Bank Feed Sensor 1	Paper detected	Paper not detected
5803 78	Bank Feed Sensor 2	Paper detected	Paper not detected
5803 79	Bank Feed Sensor 3	Paper detected	Paper not detected
5803 80	Bank Vertical Feed Sensor 1	Paper detected	Paper not detected
5803 81	Bank Vertical Feed Sensor 2	Paper detected	Paper not detected
5803 82	Bank Vertical Feed Sensor 3	Paper detected	Paper not detected
5803 83	Bank Cover Sensor 1		
5803 84	Bank Cover Sensor 2		
5803 94	GAVD Open/Close Detection	-	-
5803 200	Scanner HP Sensor	Not HP	HP
5803 201	Platen Cover Sensor	Open	Close

Table 1: Paper Size Switch (Tray 1)

Switch 1 is used for tray set detection.

0: Pushed, 1: Not pushed

Models		Paper size sensor		
North America	Europe/Asia	1	2	3
A4	A4	0	1	1
LT	LT	1	1	1
Exe	Exe	1	1	0
HLT	A5	0	0	0
-	A6	1	0	0

Table 2: Paper Size Switch (Tray 2)

Switch 1 is used for tray set detection.

0: Pushed, 1: Not pushed

Models		Paper size sensor		
North America	Europe/Asia	1	2	3
LG	LG	0	0	0
A4	A4	0	1	1
HLT	A5	0	1	0
LT	LT	1	1	1
Exe	Exe	1	1	0
A6	A6	0	0	1
B6, B5	B6, B5	1	0	0

5

Table 3: Paper Size Switch (Tray 3 and 4)

Switch 1 is used for tray set detection.

0: Pushed, 1: Not pushed

Models		Paper size sensor		
North America	Europe/Asia	1	2	3
LG	LG	0	0	0
A4	A4	0	1	1
HLT	A5	0	1	0
LT	LT	1	1	1
Exe	Exe	1	1	0
A6	A6	0	0	1
B6, B5	B6, B5	1	0	0

ARDF

6007	Description	Reading	
		0	1
6007 9	Original Set Sensor	Paper not detected	Paper detected
6007 13	Registration Sensor	Paper not detected	Paper detected
6007 15	Feed Cover	ADF cover close	ADF cover open
6007 17	Inverter Sensor	Paper not detected	Paper detected

Internal Finisher

6145	Description	Reading	
		0	1
6145 1	Entrance Sensor	Paper not detected	Paper detected
6145 2	Paper Exit Sensor	Paper not detected	Paper detected
6145 3	Jogger Fence HP Sensor	Paper not detected	Paper detected
6145 4	Shift Roller HP Sensor	Paper not detected	Paper detected
6145 5	Hitroll HP Sensor (Gathering Roller Sensor)	Paper not detected	Paper detected
6145 6	Exit Guide Plate Sensor	Paper not detected	Paper detected
6145 7	Staple Tray Paper Sensor	Paper not detected	Paper detected
6145 8	Shift Tray Paper Sensor	Paper not detected	Paper detected
6145 9	Shift Tray Full Sensor	Paper not detected	Paper detected
6145 10	Stapler Rotation Sensor (Stapler HP Sensor)	Paper not detected	Paper detected
6145 11	Staple Near End Sensor	Paper not detected	Paper detected
6145 12	Staple Self Priming Sensor	Paper not detected	Paper detected
6145 13	Front Door SW	Front door closed	Front door open

Output Check Table

Copier

5804	Display	Description
5804 3	Drum Motor: K: 260mm/s	-
5804 4	Drum Motor: K: 182mm/s	-
5804 5	Drum Motor: K: 85mm/s	-
5804 10	Fusing Motor: 260mm/s	-
5804 11	Fusing Motor: 182mm/s	-
5804 12	Fusing Motor: 85mm/s	-
5804 17	Development Motor: CMY: 260mm/s	-
5804 18	Development Motor: CMY: 182mm/s	-
5804 19	Development Motor: CMY: 85mm/s	-
5804 24	Drum Motor: CMY: 260mm/s	-
5804 25	Drum Motor: CMY: 182mm/s	-
5804 26	Drum Motor: CMY: 85mm/s	-
5804 31	Feed Motor: 364mm/s	-
5804 32	Feed Motor: 260mm/s	-
5804 33	Feed Motor: 182mm/s	-
5804 34	Feed Motor: 85mm/s	-
5804 39	Registration Motor: 260mm/s	-
5804 40	Registration Motor: 182mm/s	-
5804 41	Registration Motor: 85mm/s	-
5804 46	Inverter Motor: CW: 468mm/s	-
5804 47	Inverter Motor: CW: 260mm/s	-

5804 48	Inverter Motor: CW: 182mm/s	-
5804 49	Inverter Motor: CW: 85mm/s	-
5804 54	Inverter Motor: CCW: 468mm/s	-
5804 55	Inverter Motor: CCW: 260mm/s	-
5804 56	Inverter Motor: CCW: 182mm/s	-
5804 57	Inverter Motor: CCW: 85mm/s	-
5804 62	Duplex Motor: CW: 260mm/s	-
5804 63	Duplex Motor: CW: 182mm/s	-
5804 64	Duplex Motor: CW: 85mm/s	-
5804 69	Duplex Motor: CCW: 468mm/s	-
5804 70	Duplex Motor: CCW: 260mm/s	-
5804 71	Duplex Motor: CCW: 182mm/s	-
5804 72	Duplex Motor: CCW: 85mm/s	-
5804 77	Vertical Feed Motor: 364mm/s	-
5804 78	Vertical Feed Motor: 260mm/s	-
5804 79	Vertical Feed Motor: 182mm/s	-
5804 80	Vertical Feed Motor: 85mm/s	-
5804 83	Transfer Belt Contact Motor: CW	-
5804 84	Transfer Belt Contact Motor: CCW	-
5804 85	Paper Transfer Roller Contact Motor: CW	-
5804 86	Paper Transfer Roller Contact Motor: CCW	-
5804 87	Toner Collection Motor: CW	-
5804 88	Toner Collection Motor: CCW	-
5804 89	1 Tray Lift Motor: CW	-
5804 90	1 Tray Lift Motor: CCW	-
5804 91	Toner Supply Motor: K	-

5804 92	Toner Supply Motor: M	-
5804 93	Toner Supply Motor: C	-
5804 94	Toner Supply Motor: Y	-
5804 95	LDU Shutter Motor: CW	-
5804 96	LDU Shutter Motor: CCW	-
5804 100	Fusing Fan: H	-
5804 101	Fusing Fan: L	-
5804 102	Fusing Fan 1: H	-
5804 103	Fusing Fan 1: L	-
5804 104	Polygon Motor: Standard Speed	-
5804 105	Polygon Motor: Middle Speed	-
5804 106	Polygon Motor: Low Speed	-
5804 107	Fusing Fan 2: H	-
5804 108	Fusing Fan 2: L	-
5804 109	Fusing Front Fan: H	-
5804 110	Fusing Front Fan: L	-
5804 111	Toner Supply Fan	-
5804 112	Drive Unit Fan	-
5804 113	Development Fan 1	-
5804 114	Development Fan 2	-
5804 115	Development Fan	-
5804 116	Laser Unit Fan	-
5804 117	Feed Fan	-
5804 118	PSU Fan	-
5804 120	Development Clutch	-
5804 121	By-pass Solenoid	-

5804 122	1 Tray Lock Solenoid	-
5804 123	1 Tray Feed Solenoid	-
5804 124	Junction Gate Solenoid 1	-
5804 125	Junction Gate Solenoid 2	-
5804 130	PP: Charge DC: Y	-
5804 131	PP: Charge DC: M	-
5804 132	PP: Charge DC: C	-
5804 133	PP: Charge DC: K	-
5804 134	PP: Development: Y	-
5804 135	PP: Development: M	-
5804 136	PP: Development: C	-
5804 137	PP: Development: K	-
5804 138	PP: D	-
5804 139	PP: T1: Y	-
5804 140	PP: T1: M	-
5804 141	PP: T1: C	-
5804 142	PP: T1: K	-
5804 143	PP: T2: +	-
5804 144	PP: T2: -	-
5804 147	PP: Charge AC: Y: 260mm/s	-
5804 148	PP: Charge AC: Y: 182mm/s	-
5804 149	PP: Charge AC: Y: 85mm/s	-
5804 154	PP: Charge AC: M: 260mm/s	-
5804 155	PP: Charge AC: M: 182mm/s	-
5804 156	PP: Charge AC: M: 85mm/s	-
5804 161	PP: Charge AC: C: 260mm/s	-

5804 162	PP: Charge AC: C: 182mm/s	-
5804 163	PP: Charge AC: C: 85mm/s	-
5804 168	PP: Charge AC: K: 260mm/s	-
5804 169	PP: Charge AC: K: 182mm/s	-
5804 170	PP: Charge AC: K: 85mm/s	-
5804 181	HST Sensor: Y	-
5804 182	HST Sensor: M	-
5804 183	HST Sensor: C	-
5804 184	HST Sensor: K	-
5804 185	TM/P Sensor: Front/Y	-
5804 186	P Sensor: M	-
5804 187	TM/P Sensor: Center/C	-
5804 188	TM/P Sensor: Rear/K	-
5804 189	PCL: FC	-
5804 190	PCL: BK	-
5804 191	Toner End Sensor 5V CTL	-
5804 192	RFID ON/OFF: K	-
5804 193	RFID ON/OFF: C	-
5804 194	RFID ON/OFF: M	-
5804 195	RFID ON/OFF: Y	-
5804 196	RFID COM ON: K	-
5804 197	RFID COM ON: C	-
5804 198	RFID COM ON: M	-
5804 199	RFID COM ON: Y	-
5804 202	Scanner Lamp	-
5804 216	LD1: K	-

5804 217	LD2: K	-
5804 218	LD1: C	-
5804 219	LD2: C	-
5804 220	LD1: M	-
5804 221	LD2: M	-
5804 222	LD1: Y	-
5804 223	LD2: Y	-
5804 224	Bank Motor 1: 364mm/s	-
5804 225	Bank Motor 1: 260mm/s	-
5804 226	Bank Motor 1: 182mm/s	-
5804 227	Bank Motor 1: 136mm/s	-
5804 228	Bank Motor 1: 85mm/s	-
5804 229	Bank Motor 2: 364mm/s	-
5804 230	Bank Motor 2: 260mm/s	-
5804 231	Bank Motor 2: 182mm/s	-
5804 232	Bank Motor 2: 136mm/s	-
5804 233	Bank Motor 2: 85mm/s	-
5804 234	Bank Motor 3: 364mm/s	-
5804 235	Bank Motor 3: 260mm/s	-
5804 236	Bank Motor 3: 182mm/s	-
5804 237	Bank Motor 3: 136mm/s	-
5804 238	Bank Motor 3: 85mm/s	-
5804 239	Bank Feed Clutch 1	-
5804 240	Bank Feed Clutch 2	-
5804 241	Bank Feed Clutch 3	-
5804 242	Bank Pick-up Solenoid 1	-

5804 243	Bank Pick-up Solenoid 2	-
5804 244	Bank Pick-up Solenoid 3	-
5804 245	Bank Tray Lock Solenoid 1	-
5804 246	Bank Tray Lock Solenoid 2	-

ARDF

6008	Display	Description
6008 3	Feed Motor: Forward	-
6008 4	Feed Motor: Reverse	-
6008 5	Relay Motor: Forward	-
6008 9	Feed Clutch	-
6008 11	Junction Gate Solenoid	-

Internal Finisher

6146	Display	Description
6146 001	Carry Motor	Transport Motor
6146 002	Exit Motor	-
6146 003	Jogger Motor	-
6146 004	Sft Motor	Shift Roller Motor
6146 005	Hitroll Motor	Gathering Roller Motor
6146 006	Exit Guide Plate Motor	-
6146 007	Tray Motor	Tray Lift Motor
6146 008	Staple Motor	-
6146 009	Stopper Solenoid	Pick-up Solenoid

Printer Service Mode

SP1-XXX (Service Mode)

1001	Bit Switch			
001	Bit Switch 1		0	1
	bit 0	DFU	-	-
	bit 1	DFU	-	-
	bit 2	DFU	-	-
	bit 3	No I/O Timeout	0: Disable	1: Enable
		Enable: The machine I/O Timeout setting will have no effect. I/O Timeouts will never occur.		
	bit 4	SD Card Save Mode	0: Disable	1: Enable
		Enable: Print jobs will be saved to an SD Card in the GW SD slot.		
	bit 5	DFU	-	-
	bit 6	DFU	-	-
bit 7	[RPCS,PCL]: Printable area frame border	0: Disable	1: Enable	
	Prints all RPCS and PCL jobs with a border around the printable area.			

1001	Bit Switch		
------	------------	--	--

002	Bit Switch 2		0	1
	bit 0	DFU	-	-
	bit 1	DFU	-	-
	bit 2	Applying a Collate Type	0: Shift Collate	1: Normal Collate
	<p>A collate type (shift or normal) will be applied to all jobs that do not explicitly define a collate type.</p> <p>Note: If BitSwitch 5-0 is enabled, this BitSwitch has no effect.</p>			
	bit 3	[PCL5e/c,PS]: PDL Auto Switching	0: Enable	1: Disable
	<p>Disable: The machine ability to change the PDL processor mid-job.</p> <p>Some host systems submit jobs that contain both PS and PCL5e/c. If Auto PDL switching is disabled, these jobs will not be printed properly.</p>			
	bit 4	DFU	-	-
	bit 5	DFU	-	-
bit 6	DFU	-	-	
bit 7	DFU	-	-	
1001	Bit Switch			

003	Bit Switch 3		0	1
	bit 0	DFU	-	-
	bit 1	DFU	-	-
	bit 2	[PCL5e/c]: Legacy HP compatibility	0: Disable	1: Enable
		Enable: Uses the same left margin as older HP models such as HP4000/HP8000. In other words, the left margin defined in the job (usually "<ESC>*r0A") will be changed to "<ESC>*r1A"		
	bit 3	DFU	-	-
	bit 4	DFU	-	-
	bit 5	DFU	-	-
	bit 6	DFU	-	-
	bit 7	DFU	-	-

1001	Bit Switch		
004	Bit Switch 4 DFU	-	-

1001	Bit Switch			
005	Bit Switch 5		0	1
	bit 0	Show "Collate Type", "Staple Type" and "Punch Type" buttons on the operation panel.	0: Disable	1: Enable
		If enabled, users will be able to configure a Collate Type, Staple Type, and Punch Type from the operation panel. The available Types will depend on the device and configured options. After enabling this BitSw, the settings will appear under: "User Tools > Printer Features > System"		

bit 1	Multiple copies if a paper size or type mismatch occurs	0: Disable (Single copy)	1: Enable (Multiple copy)
	If a paper size or type mismatch occurs during the printing of multiple copies, only a single copy is output by default. Using this BitSw, the device can be configured to print all copies even if a paper mismatch occurs.		
bit 2	Prevent SDK applications from altering the contents of a job.	0: Disable	1: Enable
	<p>If this BitSw is enabled, SDK applications will not be able to alter print data. This is achieved by preventing SDK applications from accessing a module called the "GPS Filter".</p> <p>Note: The main purpose of this BitSw is for troubleshooting the effects of SDK applications on data.</p>		
bit 3	[PS] PS Criteria	0: Pattern3	1: Pattern 1
	<p>Change the number of PS criterion used by the PS interpreter to determine whether a job is PS data or not.</p> <p>Pattern3: includes most PS commands.</p> <p>Pattern 1: A small number of PS tags and headers</p>		
bit 4	Increase max number of the stored jobs to 1000 jobs.	0: Disable (100)	1: Enable (1000)
	Enable: Changes the maximum number of jobs that can be stored on the HDD via Job Type settings to 1000. The default is 100.		
bit 5	DFU	-	-
bit 6	Method for determining the image rotation for the edge to bind on.	0: Disable	1: Enable
	<p>If enabled, the image rotation will be performed as they were in the specifications of older models for the binding of pages of mixed orientation jobs.</p> <p>The old models are below:</p> <ul style="list-style-type: none"> - PCL: Pre-04A models - PS/PDF/RPCS:Pre-05S models 		

	bit 7	Letterhead mode printing	0: Disable	1: Enable (Duplex)
	<p>Routes all pages through the duplex unit.</p> <p>If this is disabled, simplex pages or the last page of an odd-paged duplex job are not routed through the duplex unit. This could result in problems with letterhead/pre-printed pages.</p> <p>Only affects pages specified as Letterhead paper.</p>			

1001	Bit Switch			
006	Bit Switch 6 DFU	-	-	

1001	Bit Switch			
007	Bit Switch 7		0	1
	bit 0	Print path	0: Disable	1: Enable
		If enabled, simplex pages (in mixed simplex/duplex PS/PCL5 jobs only) and the last page of an odd paged duplex job (PS, PCL5, PCL6) are always routed through the duplex unit. Not having to switch paper paths increases the print speed slightly.		
bit 1 to 7	DFU	-	-	

1001	Bit Switch			
-------------	-------------------	--	--	--

008	Bit Switch 8		0	1
	bit 0 to 2	DFU	-	-
	bit 3	[PCL,PS]: Allow BW jobs to print without requiring User Code	0: Disable	1: Enable (allow BW jobs to print without a user code)
		BW jobs submitted without a user code will be printed even if user code authentication is enabled. Note: Color jobs will not be printed without a valid user code.		
bit 4 to 7	DFU	-	-	

1001	Bit Switch
------	------------

009	Bit Switch 9		0	1
	bit 0	PDL Auto Detection timeout of jobs submitted via USB or Parallel Port (IEEE 1284).	0: Disable (Immediately)	1: Enable (10 seconds)
		To be used if PDL auto-detection fails. A failure of PDL auto-detection does not necessarily mean that the job cannot be printed. This bit switch tells the device whether to time-out immediately (default) upon failure or to wait 10 seconds.		
	bit 1 to 3	DFU	-	-
	bit 4	Timing of the PDL Status ReadBack (JOB END) when printing multiple collated copies.	Disabled	Enabled
<p>This bit determines the timing of the PDL USTATUS JOB END sent when multiple collated copies are being printed.</p> <p>0 (default): JOB END is sent by the device to the client after the first copy has completed printing. This causes the page counter to be incremented after the first copy and then again at the end of the job.</p> <p>1: JOB END is sent by the device to the client after the last copy has finished printing. This causes the page counter to be incremented at the end of each job.</p>				
bit 5 to 7	DFU	-	-	

1003	[Clear Setting]	
1003 001	Initialize System	Initializes settings in the System menu of the user mode.
1003 003	Delete Program	DFU

1004	[Print Summary]	
1004 001	Service Summary	Prints the service summary sheet (a summary of all the controller settings).

1005	[Display Version]	
1005 001	Printer Version	Displays the version of the controller firmware.

1006	[Sample/ Locked Print]	
1006 001	Enables and disables the document server. When you select "0," the document server is enabled or disabled in accordance with Copy Service Mode SP5-967. When you select "1," the document server is enabled regardless of Copy Service Mode SP5-967.	

1101	[Data Recall]	
1101 001	Factory	Recalls a set of gamma settings. This can be either a) the factory setting, b) the previous setting, or c) the current setting.
1101 002	Previous	
1101 003	Current	
1101 004	ACC	

1102	[Resolution Setting]	
	Selects the printing mode (resolution) for the printer gamma adjustment.	
1102 001	2400x600 Photo , 1800x600 Photo, 600 x 600 Photo, 2400x600 Text, 1800x600, Text, 600x600 Text	

1103	[Test Page]	
	Prints the test page to check the color balance before and after the gamma adjustment.	
1103 001	Color Gray Scale	
1103 002	Color Pattern	

1104	[Gamma Adjustment]	
	Adjusts the printer gamma for the mode selected in the "Mode Selection" menu.	

1104 001	Black: Highlight	[0 to 30 / 15 / 1/step]
1104 002	Black: Shadow	
1104 003	Black: Middle	
1104 004	Black: IDmax	
1104 021	Cyan: Highlight	
1104 022	Cyan: Shadow	
1104 023	Cyan: Middle	
1104 024	Cyan: IDmax	
1104 041	Magenta: Highlight	[0 to 30 / 15 / 1/step]
1104 042	Magenta: Shadow	
1104 043	Magenta: Middle	
1104 044	Magenta: IDmax	
1104 061	Yellow: Highlight	
1104 062	Yellow: Shadow	
1104 063	Yellow: Middle	
1104 064	Yellow: IDmax	

1105	[Save Tone Control Value]	
	Stores the print gamma adjusted with the "Gamma Adj." menu item as the current setting. Before the machine stores the new "current setting", it moves the data currently stored as the "current setting" to the "previous setting" memory storage location.	
1105 001	Save Tone Control Value	

1106	[Toner Limit]	
	Adjusts the maximum toner amount for image development.	
1106 001	TonerLimitValue	[100 to 400 / 260 / 1%/step]

1110	[Media Print Device Setting]	
	Enable or disable the media print support function.	
1110 001	-	[0 to 1 / 1 / 1/step] 0: Disable, 1: Enable

1111	[All Job Delete Mode]	
	C*	[0 or 1 / 1 / 1/step] 0: Excluding New Job 1: Including New Job Selects whether to include an image processing job in jobs subject to full cancellation from the SCS job list.

Scanner Service Mode

SP1-xxx (System and Others)

1001	[Scan NV Version]		
	Displays the scanner firmware version stored in NVRAM.		
1001 5	-	*CTL	-
1005	[Erase margin (Remote Scan)]		
	Creates an erase margin for all edges of the scanned image. If the machine has scanned the edge of the original, create a margin. This SP is activated only when the machine uses TWAIN scanning.		
1005 1	Range from 0 to 5 mm	*CTL	[0 to 5 / 0 / 1 mm/step]
1009	[Remote scan disable]	*CTL	[0 or 1 / 0 / -] 0: enable, 1: disable
1009 1	Enable or disable remote scan.		
1010	[Non Display Clear Light PDF]	*CTL	[0 or 1 / 0 / -] 0: Display, 1: No display
1010 1	Enable or disable remote scan.		
1011	[Org Count Display]	*CTL	[0 or 1 / 0 / -] 0: No display, 1: Display
1011 1	This SP codes switches the original count display on/off.		
1012	[User Info Release]	*CTL	[0 or 1 / 1 / -] 0: Do not release, 1: Release

1012 1	<p>This SP code sets the machine to release or not release the following items at job end.</p> <ul style="list-style-type: none"> • Destination (E-mail/Folder/CS) • Sender name • Mail Text • Subject line • File name
--------	--

1013	[Scan to Media Device Setting]	*CTL	<p>[0 or 1 / 1 / -] 0: Disable, 1: Enable</p>
1013 1	<p>This SP code enables/disables the multi-media function option (USB 2.0/SD Slot) mounted on the left rear corner of the machine. Operators can scan documents to either an SD card or a USB memory device inserted into this unit. This SP must be enabled (set to "1") in order for the device to function.</p>		

1014	[Scan to Folder Pass Input Set]		
	0: OFF 1: ON		
001	C*	<p>Default: OFF Enables / Disables password entry for Scan To Folder.</p>	

1040	[Scan: LT/LG Mixed Sizes Settings]		
	<p>[0 to 1/1/1 Step] NA [0 to 1/0/1 Step] Other 1: Enable 0: Disable</p>		

1041	[Scan: Flair API Setting]		
	0x00 - 0xff		
001	C*	<p>(7) 0000 0000 (1) Set Bit Switch descriptions below.</p>	
	<p>Sets Scanner FlairAPI Function enable / disable. This SP is set by BitSwitch and needs to reboot the machine after making changes.</p>		

Bit	Setting	Meaning		Description
		0	1	
bit 0	Start of Flair API Server	Off	On	Sets whether to start exclusive FlairAPI http server. If "0", scanning FlairAPI function and simple UI function are disabled. The machine installed Android operating panel option, set "1", others set "0".
bit 1	Access permission of FlairAPI from outside of the machine	Disable	Enable	If "0", accessing is limited from the machine only, such as operating panel, SDK/J, MFP browsers etc. If "1", accessing is allowed from outside of FlairAPI such as PC, Remote UI, and IT-Box etc...
bit 2	Reserved	-	-	-
bit 3	Reserved	-	-	-
bit 4	Simple UI Function	Disable	Enable	If "1", the machine can be used Scanner Simple UI. If "0", requesting URL of Simple UI returns "404 Not Found"
bit 5	Accessing permission of Simple UI from outside of the machine	Disable	Enable	If "0", accessing is limited from the machine only (operating panel and MFP browser). If "1", accessing is allowed from outside of Simple UI such as PC, mobile devices, and so on.
bit 6	Reserved	-	-	-
bit 7	Reserved	-	-	-

SP2-XXX (Scanning-image quality)

2021	[Compression Level (Gray-scale)]		
	Selects the compression ratio for grayscale processing mode (JPEG) for the three settings that can be selected at the operation panel.		
2021 1	Comp1: 5-95	*CTL	[5 to 95 / 20 / 1 /step]
2021 2	Comp2: 5-95		[5 to 95 / 40 / 1 /step]
2021 3	Comp3: 5-95		[5 to 95 / 65 / 1 /step]
2021 4	Comp4: 5-95		[5 to 95 / 80 / 1 /step]
2021 5	Comp5: 5-95		[5 to 95 / 95 / 1 /step]

2024	[Compression ratio of ClearLight PDF]		
	Selects the compression ratio for clearlight PDF for the two settings that can be selected at the operation panel.		
2024 1	Compression Ratio (Normal)	*CTL	[5 to 95 / 25 / 1 /step]
2024 2	Compression Ratio (High)		[5 to 95 / 20 / 1 /step]

2025	[Compression ratio of ClearLight PDF JPEG2000]		
	Selects the compression ratio for clearlight PDF JPEG2000 for the two settings that can be selected at the operation panel.		
2025 1	Compression Ratio (Normal)	*CTL	[5 to 95 / 25 / 1 /step]
2025 2	Compression Ratio (High)		[5 to 95 / 20 / 1 /step]

2030	[OCR PDF DetectSens]		
001	White Lumi Value: 0 - 255	C*	<p>[0 to 255 / 250 / 1/step]</p> <p>Sets brightness that consider a white: Information of detection level 5 at white paper detection enable of PDF setting with OCR "Transparent text".</p> <p>1 to 4 : Lowest sensitivity to highest sensitivity User can set sensitivity for level 5.</p>

002	White Pix Ratio: 0 - 100	C*	[0 to 100 / 80 / 1/step] Sets part 2: Information of detection level 5 at white paper detection enable of PDF setting with OCR "Transparent text".
003	White Tile Ratio: 0 - 100	C*	[0 to 100 / 80 / 1/step] Sets part 3: Information of detection level 5 at white paper detection enable of PDF setting with OCR "Transparent text".

Firmware Update

To update the firmware for this machine, you must have the new version of the firmware downloaded onto an SD (Secure Digital) Card. The SD Card is inserted into SD Card Slot 2 on the left rear side of the controller box.

Type of Firmware

There are several types of firmware as shown below.

Type of firmware	Function	Location of firmware
PCL Font	PCL fonts	Flash ROM on the controller board
Font EXP	PS3 fonts	Flash ROM on the controller board
OpePanel	Operation panel system	Flash ROM on the controller board
Engine	Printer engine control	BCU Flash ROM
System/Copy	Operating system	Flash ROM on the controller board
Power Saving Sys	Power Saving Sys	Flash ROM on the controller board
Fax	Feature application	Flash ROM on the controller board
Scanner	Feature application	Flash ROM on the controller board
Animation	Animation	Flash ROM on the controller board
Data Erase Onb	HDD encryption/ Data Overwrite	Standard Security & Encryption unit SD card
PDF	Page description language	Flash ROM on the controller board

Type of firmware	Function	Location of firmware
Web Support	Document server application	Flash ROM on the controller board
Web Uapl	Web Service application	Flash ROM on the controller board
Network Support	Network Interface/ Security control	Flash ROM on the controller board
Network Doc Box	Feature application	Flash ROM on the controller board
Printer	Feature application	Flash ROM on the controller board
RPCS	Page description language (RPCS for XPS driver data process)	Flash ROM on the controller board
PCL	Page description language (PCL)	Flash ROM on the controller board
PS3	PostScript3 fonts	Flash ROM on the controller board
PCL	PCL fonts	Flash ROM on the controller board

Before You Begin

An SD card is a precision device. Always observe the following precautions when you handle SD cards:

- Always switch the machine off before you insert an SD card. Never insert the SD card into the slot with the power on.
- Do not remove the SD card from the service slot after the power has been switched on.
- Never switch the machine off while the firmware is downloading from the SD card.
- Keep SD cards in a safe location where they are not exposed to high temperature, high humidity, or exposure to direct sunlight.
- Always handle SD cards with care. Do not bend or scratch them. Do not let the SD card get exposed to shock or vibration.

- Make sure that the write protection of an SD card is unlocked when you download an application to it. If not, downloading fails and a download error (e.g. Error Code 44) occurs during a firmware upgrade.

Keep the following points in mind when you use the firmware update software:

- "Upload" means to send data from the machine to the SD card. "Download" means to send data from the SD card to the machine.
- To select an item on the LCD, touch the appropriate button on the soft touch-screen of the LCD, or, press the appropriate number key on the 10-key pad of the operation panel. For example, when "Exit (0)" shows on the screen you can touch the Exit button on the screen, or, press the "0" button on the operation panel of the copier.
- Make sure that the machine is disconnected from the network to prevent a print job for arriving while the firmware update is in progress before you start the firmware update procedure.

5

Updating Firmware

Preparation

- If the SD card is blank, copy the entire "romdata" folder onto the SD card.
- If the card already contains the "romdata" folder, copy the "D191" folder onto the card.

If the card already contains folders up to "D191", copy the necessary firmware files (e.g. D191*.fwu) into this folder.

Note

- Do not put multiple machine firmware programs on the same SD card. Copy the only model firmware you want.

Updating Procedure

Here is the general procedure for updating the firmware.

1. Turn the main power switch off.
2. Wait at least two minutes for the operation panel display to go off.
3. Disconnect the network cable from the copier if the machine is connected to a network.
4. Remove the slot cover (🔑 x 1).
5. Insert the SD card into SD Card Slot 2. Make sure the label on the SD card faces the front side of the machine.
6. Slowly push the SD card into the slot so it locks in place. You will hear it click. Make sure the SD card locks in place.
7. Switch the main power switch on. You will see a message:

Preparing to start firmware update

8. On the screen, touch the button (or press the corresponding number key on the operation panel) to select the item in the menu that you want to update.

ROM/NEW	What it means
ROM:	Tells you the number of the module and name of the version currently installed. The first line is the module number, the second line the version name.
NEW:	Tells you the number of the module and name version on the SD card. The first line is the module number, the second line the version name.

9. Select the item for the update, and then touch "UpDate (#)".
 - The "OpePanel", "Engine" and "System/Copy" must be updated one at a time.
 - This means that you must select one, execute the update, and then turn the machine off when you see the "Update is Done" message.
 - A line of asterisks (*** _____) is displayed as the update proceeds. The update may require several minutes as these are large modules.
 - As for the other modules, more than one can be selected for update. Just select all the modules that you want to update, and then execute.
 - The modules selected for update will appear highlighted. To unselect a module just touch the name again to switch off the highlight.
10. Touch "UpDate (#)" (or # key) to start the update.
11. The "Update is Done" message appears on the operation panel after the update is finished.
12. Switch the machine off when you see the "Update is Done" message or follow the procedure displayed on the operation panel.
13. Press in the SD card to release it. Then remove it from the slot.
14. Re-connect any cables that have been disconnected.
15. Switch the machine on for normal operation.

Error Messages

An error message shows in the first line if an error occurs during the download.

The error code consists of the letter "E" and a number. The example above shows error "E24" displayed. For details, refer to the Error Message Table (see "Handling Firmware Update Error").

Firmware Update Error

If a firmware update error occurs the machine will display an error message, a number prefixed with an "E" (E34 for example). This means the update was cancelled during the update because the module selected for update was not on the SD card.

Recovery after Power Loss

If the ROM update is interrupted as a result of accidental loss of power while the firmware is updating, then the correct operation of the machine cannot be guaranteed after the machine is switched on again.

- If the ROM update does not complete successfully for any reason, then in order to ensure the correct operation of the machine, the ROM update error will continue to show until the ROM is updated successfully.
- In this case, insert the card again and switch on the machine to continue the firmware download automatically from the card without the menu display.

5

Browser Unit Update Procedure

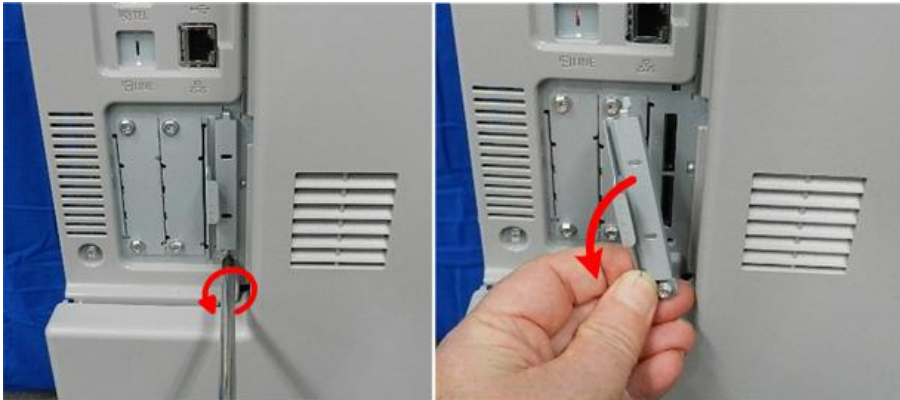

d191b0007

1. Remove the SD card slot cover (1 x1).
2. Remove the VM card from slot 2.
3. Turn the SD-card label face of the browser unit to the front of the machine. Then push it slowly into slot 2 until you hear a click.
4. Plug in and turn on the main power switch.
5. Push the "User Tools" key.
 - If an administrator setting is registered for the machine, step 5 and 6 are required. Otherwise, skip to the step 7.
6. Push the "Login/ Logout" key.

7. Login with the administrator user name and password.
8. Touch "Extended Feature Settings" twice on the LCD.
9. Touch "Uninstall" on the LCD.
10. Touch the "Browser" line.
11. Confirmation message appears on the LCD.
12. Touch "Yes" to proceed.
13. Reconfirmation message appears on the LCD.
14. Touch "Yes" to uninstall the browser unit.
15. You will see "Uninstalling the extended feature... Please wait.", and then "Completed".
16. Touch "Exit" to go back to the setting screen.
17. Exit "User/Tools" setting, and then turn off the main power switch.
18. Remove the SD card of the browser unit from SD card slot 2.
19. Overwrite the updated program in the "sdk" folder of the browser unit application with PC.
20. Do the "Installation Procedure" to install the browser unit.

Handling Firmware Update Errors

An error message shows in the first line if an error occurs during a download. The error code consists of the letter "E" and a number ("E20", for example).

Error Message Table

Code	Meaning	Solution
20	Cannot map logical address	Make sure the SD card is inserted correctly.
21	Cannot access memory	HDD connection incorrect or replace hard disks.
22	Cannot decompress compressed data	Incorrect ROM data on the SD card, or data is corrupted.
23	Error occurred when ROM update program started	Controller program abnormal. If the second attempt fails, replace controller board.
24	SD card access error	Make sure SD card inserted correctly, or use another SD card.
30	No HDD available for stamp data download	HDD connection incorrect or replace hard disks.

31	Data incorrect for continuous download	Insert the SD card with the remaining data required for the download, then re-start the procedure.
32	Data incorrect after download interrupted	Execute the recovery procedure for the intended module download, then repeat the installation procedure.
33	Incorrect SD card version	Incorrect ROM data on the SD card, or data is corrupted.
34	Module mismatch - Correct module is not on the SD card)	SD update data is incorrect. Acquire the correct data (Japan, Overseas, OEM, etc.) then install again.
35	Module mismatch - Module on SD card is not for this machine	SD update data is incorrect. The data on the SD card is for another machine. Acquire correct update data then install again.
36	Cannot write module - Cause other than E34, E35	SD update data is incorrect. The data on the SD card is for another machine. Acquire correct update data then install again.
40	Engine module download failed	Replace the update data for the module on the SD card and try again, or replace the BCU board.
42	Operation panel module download failed	Replace the update data for the module on the SD card and try again, or replace the LCDC.
43	Stamp data module download failed	Replace the update data for the module on the SD card and try again, or replace the hard disks.
44	Controller module download failed	Replace the update data for the module on the SD card and tray again, or replace controller board.
50	Electronic confirmation check failed	SD update data is incorrect. The data on the SD card is for another machine. Acquire correct update data then install again.

SFU (Smart Firmware Update)

Overview

SFU (Smart Firmware Update): New Feature for Firmware update

Firmware can be updated through a simple operation (can be controlled from operation panel) only if the machine is connected to @Remote.

The firmwares for mainframe are packaged into one firmware for the SFU.

Therefore the package firmware can be updated at once. SFU allows you to reduce the time of the firmware update and to manage latest version of necessary firmwares on machines.

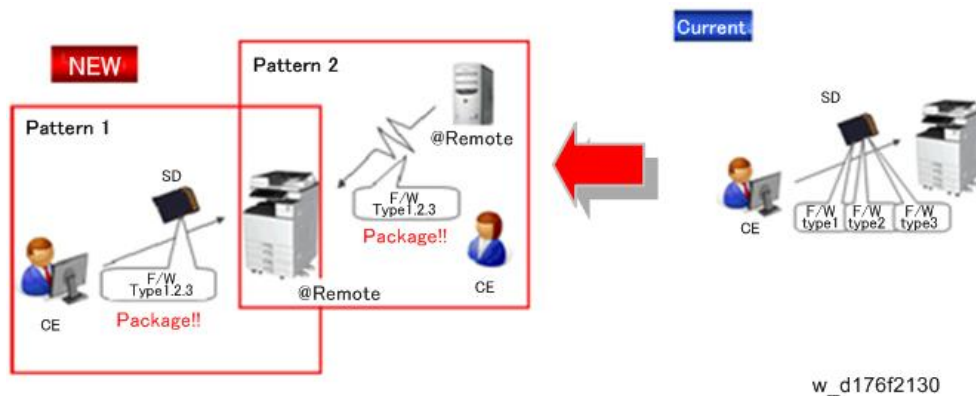

Various type of new firmware updates

- **SFU:** SD card does not need for updating firmware. The machine can be updated firmware by very easy steps.
- **RFU (with new package firmware):** The firmware for the mainframe is packaged to one firmware. As the result, the machine can be updated to the most of the latest mainframe firmwares by a single RFU operation.

SD card

- **PFU (Package firmware update):** The package firmware can also be used for SD card update. It can achieve to reduce the time of the firmware update and maintains latest version of necessary firmwares on machines.

↓ Note

- We also still prepare the individual firmware. If the machine needs specific firmware, you can update the individual firmware.
- Not all the individual firmwares are packaged. For example, Java VM, firmware for finisher etc, do not included in package firmware.

- Updating will be executed if the individual firmware in the package is newer than the installed firmware in the machine. If the version of the individual firmware is the same or older than the one already installed, the firmware update will be skipped.
- Package includes only several firmwares at the delivery. When a newer version of the firmware is available, the new firmware will be added into the package.

The approximate time of updating package firmware

Configuration	File size	Total required time to update	Time to validate the config.	Update time
Maximum configuration	147MB	23 min. 05 sec.	2 min. 20 sec.	20 min. 45 sec.
Minimum configuration	60MB	8 min. 37 sec.	1 min. 06 sec.	7 min. 31 sec.

5

SFU Procedure

Note

- Following images may be different from those on the actual screen.

1. Enter into the SP mode.



d191z5011

2. Touch [Firmware Update].



d191z5012

3. Select [Update].

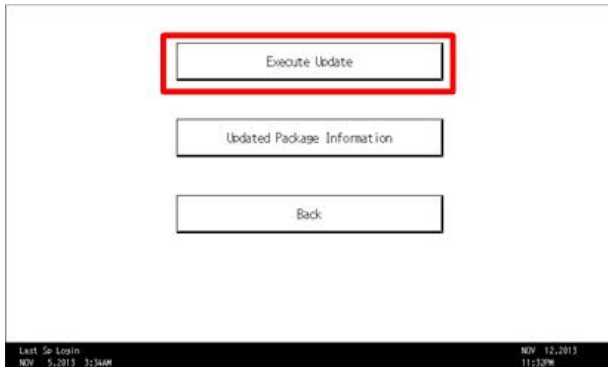

d191z5013

4. Touch [Execute Update].

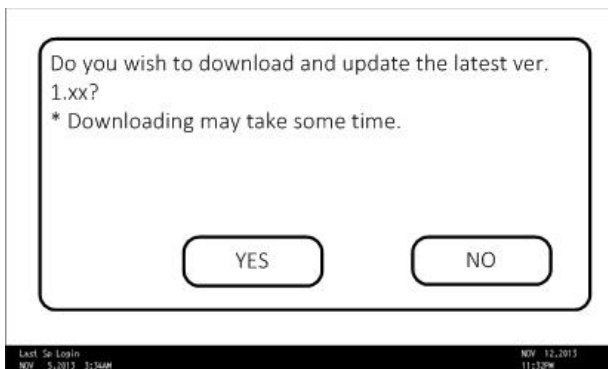

d191z5014

5. Touch [YES].

6. The receiving progress message is displayed until the target firmware has been received.

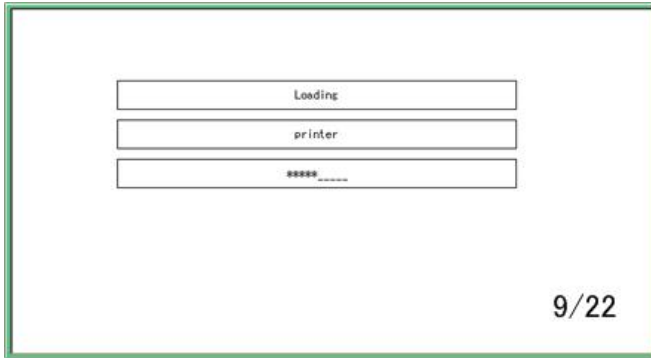

d176f2113

7. When the data is received completely, the following display shows up.

Note

- "9/22" in the image shows "completed numbers of firmware / total numbers of update firmware". So "22/22" indicates all the update firmware has been updated.

8. When the step 4 has been done successfully, the machine will reboot automatically.

How to Set a Reservation

1. Enter into the SP mode.



d191z5011

2. Touch [Firmware Update].



d191z5015

3. Touch [Reserve].



d191z5016

4. Touch [Reservation setting].

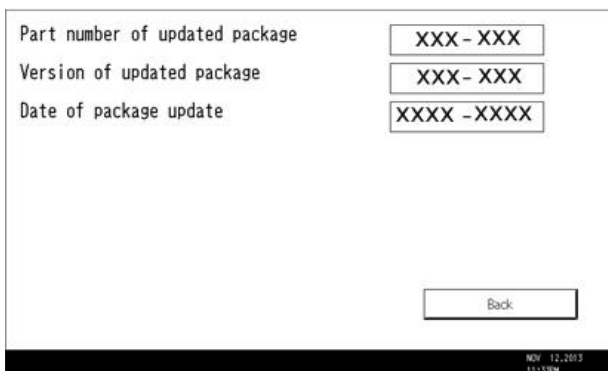

d191z5017

5. The display shown above will show up if the package in the machine is the latest.

↓ Note

- If the firmware in the machine is obsolete, the following display will show up instead.

- Set the reservation setting to configure the next time to visit (Initial value: 1). The input method is the same as the SP mode and the value is stored in the NV-RAM.



Start obtaining a new package

[Setting item] Next time to visit the customer

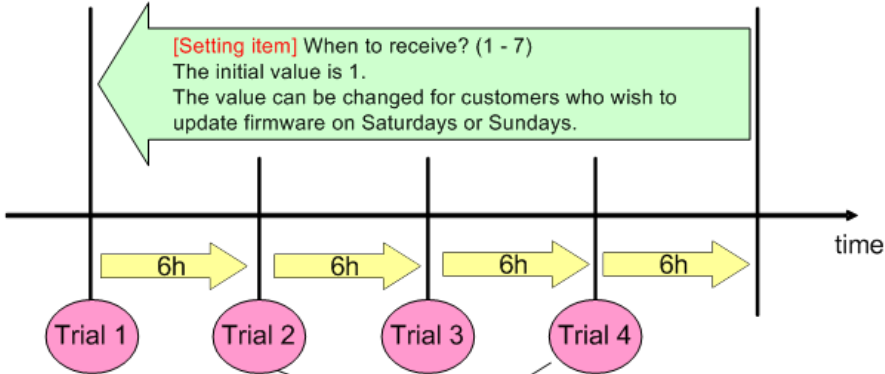

Performs only when the previous trial is failed.

w_d176f2129

5

- In this process, there are four times to try obtaining a new package with the initial setting, including retry actions.
- If a trial has obtained a new package successfully, the next trials are not performed.
- If a trial failed to obtain a new package because the main power switch is OFF or so, the process will perform a next trial 6 hours later.
- If the retry actions keep failing and the revisit day has come, the retry action of the day is no longer performed.

Checking the reserved and received package information

1. Enter into the SP mode.



d191z5011

2. Touch [Firmware Update].



d191z5015

3. Touch [Reserve].

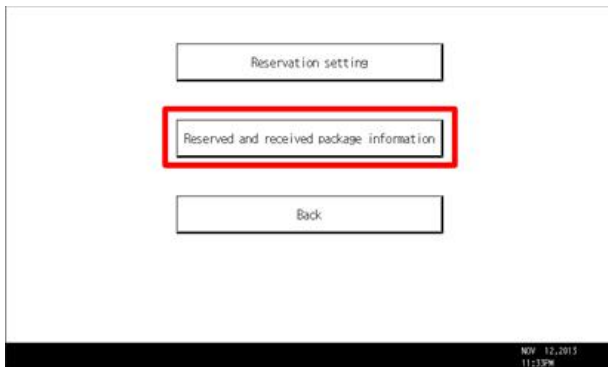

d191z5018

4. Touch [Reserve and received package information].

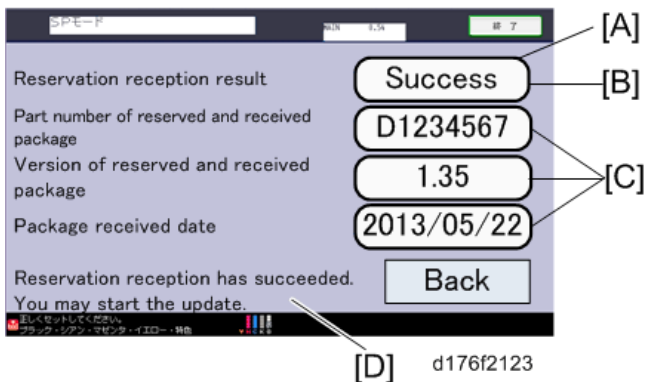

5. Check the reserved and received package information.

Note

- All items will be displayed “-”, when the reserved and received package is the latest and after update completed, because there is no package file in a area for reception located in HDD.

	Description
[A]	If there is no received package, “-” is displayed on all the items. Each four items will be updated with refreshing the display, when a package received successfully or failed to receive.
[B]	If error occurs, the error code will be displayed here.
[C]	If error occurs, “-” will be displayed here.
[D]	This message will be appeared only when the reservation reception has been done successfully.

5

Update the Package Firmware via SD Card

1. Insert the SD card which contains a package into SD card slot.
2. Turn the power ON.

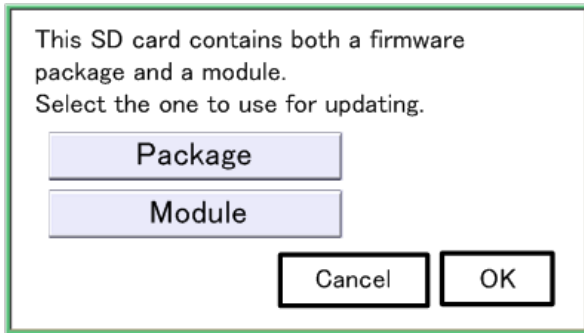

d176f2128

3. When the following display shows up, select [Package] and tap [OK].

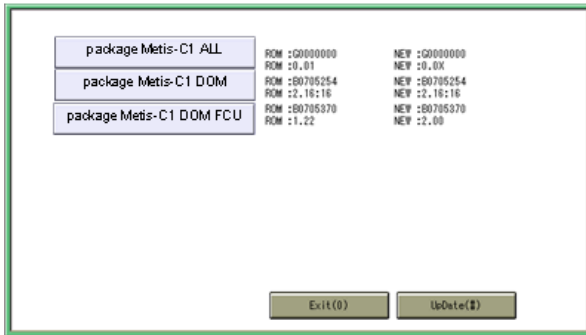

d176f2127

4. Touch [Execute].
5. The receiving progress message is displayed until the target firmware has been received.

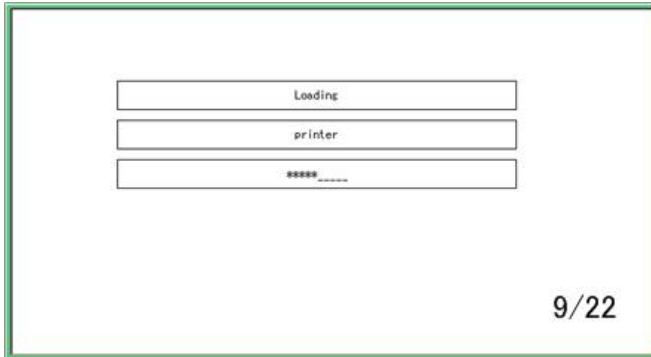

d176f2113

6. The display shown above will show up, and the update will be completed.

Note

- "9/22" in the image shows "completed numbers of firmware / total numbers of update firmware". So "22/22" indicates all the update firmware has been updated.

Updating JavaVM

Creating an SD Card for Updating

1. Download the update modules from Firmware Download Center. As one of the model modules, "Java VM v12 UpdateTool" is available for download. (The version differs depending on the model.)
2. Unzip the downloaded file. Copy the whole "sdk" folder to the root of the SD card directly below.

Note

- When unzipping the downloaded file, two subfolders ("update" and "sdk") exist in the "sdk" folder. Rather than just copying the subfolder "sdk", copy the whole folder "sdk".

5

Updating Procedure

CAUTION

- SD card can be inserted with the machine power off.
 - During the updating process, do not turn off the power.
 - If you turn off the power during the updating, the machine performance is not guaranteed. (There is a possibility that an SC and boot failure occurs.)
 - If you accidentally turn off the power during the updating, retry the updating procedure from the beginning. (If the update fails again, you will need to replace the controller board.)
1. If the boot priority application is set to the ESA application, switch to the copy application. ([System Settings]-[General Features]-[Function Priority])
 2. Insert the SD card you created into the service slot, and then turn ON the main power switch.



3. After booting Java VM, update of the application is started. "Updating SDK/J" appears in the banner message of the touch panel display. (Estimated time: about 2 minutes)

4. When the update is complete, "Update SDK / J done SUCCESS" will appear in the banner message of the touch panel display.
5. The Java VM will automatically reboot after "Update SDK / J done SUCCESS" message appears.

CAUTION

- Never turn off the main power during the Java VM rebooting. Otherwise, registration data in the Java VM may be broken and the Java VM may not be recovered.
6. Check if the Java VM is activated or not on the "Extended Feature Settings" (User Tools/Counter > Extended Feature Settings > Extended Feature Settings).
 7. After turning off the power, remove the SD card from the slot.
When you fail to update, "Update SDK/J done FAIL" is displayed. You can confirm the cause of the error message below.
 8. Reconfigure the Heap size. ([Extended Feature Settings]-[Administrator Tools]-[Heap/Stack Size Settings]). See the manual for the ESA application to know what value to set for the heap size.
 9. Return to the previous setting for the boot priority application.

List of Error Messages

Update results are output as a text file on the SD card called "sdkjversionup.log" in the "\sdk \update" folder.

Result	File contents	Description of the output
Success	script file = /mnt/sd2/sdk/update/ bootscript 2012/08/22 17:57:47 start 2012/08/22 17:59:47 end SUCCESS	Boot script path Boot scripts processing start time End time boot script processing, the results
Failure	script file = /mnt/sd2/sdk/update/ bootscript 2012/08/22 17:57:47 start XXXX Error 2012/08/22 17:57:57 end FAIL	Boot script path Boot scripts processing start time Error message (Possibly multiple) End time boot script processing, the results

Error Message	Cause	Remedy
PIECEMARK Error,machine=XXXXX	Applied the wrong updating tool (Using the updating tool of a different model)	Use the correct updating tool for this model.

Error Message	Cause	Remedy
<p>pasePut() - error : The file of the copy origin is not found.</p> <p>Put Error!</p>	<p>Inadequacy with the SD card for updating</p> <p>(Files are missing in the updating tool)</p>	<p>Re-create the SD card for updating.</p>
<p>paseCopy() - error : The file of the copy origin is not found.</p> <p>Copy Error!</p>	<p>Inadequacy SD card for updating</p> <p>(Files in the updating tool are missing)</p>	<p>Inadequacy SD card for updating</p> <p>(Files in the updating tool are missing)</p>
<p>[file name: XX] error, No space left on device pasePut() - error : The destination directory cannot be made.</p> <p>pasePut() - error : fileCopy Error.</p> <p>Put Error!</p>	<p>Writing destination is full. (The NAND flash memory on the controller board is full.)</p>	<p>Uninstall the unnecessary SDK applications.</p> <p>If you can not uninstall it, implement escalation, stating the "model name, application configuration, SMC sheet (SP5-990-006/024/025), and error file."</p>
<p>[file name: XX] error, No space left on device paseCopy() - error : The destination directory cannot be made.</p> <p>paseCopy() - error : fileCopy Error.</p> <p>Copy Error!</p>	<p>Writing destination is full. (The NAND flash memory on the controller board is full.)</p>	<p>Uninstall the unnecessary SDK applications.</p> <p>If you can not uninstall it, implement escalation stating the "model name, application configuration, SMC sheet (SP5-990-006/024/025), and error file."</p>
<p>Put Error! * 1</p> <p>Copy Error! * 1</p> <p>Delete Error!</p> <p>[XXXXX] is an unsupported command.</p> <p>Version Error</p>	<p>Error, not normally expected to occur</p>	<p>If you cannot uninstall it, implement escalation stating the "model name, application configuration, SMC sheet (SP5-990-006/024/025), and error file."</p> <p>* 1</p> <p>Without the foregoing error message, only "Put Error / Copy Error" will be displayed</p>

Installing Another Language

Many languages are available. But you can only switch between five languages at a time. Do the following procedure to select the five languages you want among 18 languages. You can select one of the 18 languages you want from the user interface on the operation panel.

1. Press the "User Tools/Counter" key on the operation panel.

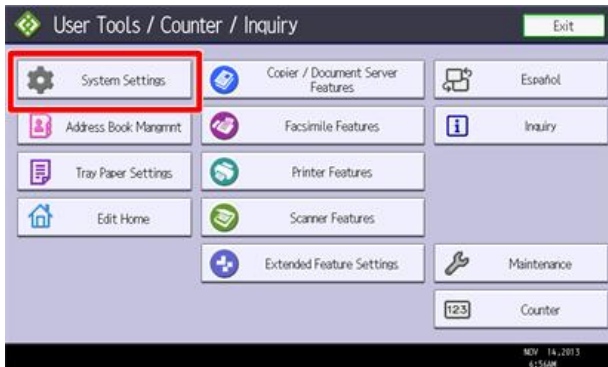

d191z5021

2. Press the "System Settings" button.

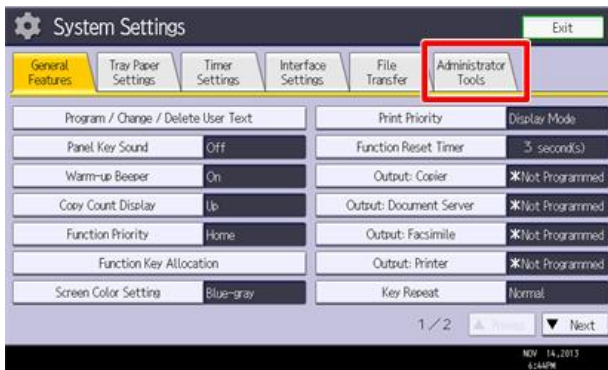

d191z5022

3. Press the "Administrator Tools" button.

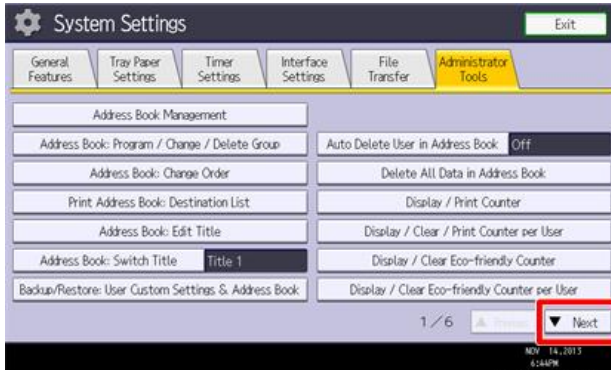

d191z5023

4. Press the "Next" button to show the "Select Switchable Language".

5

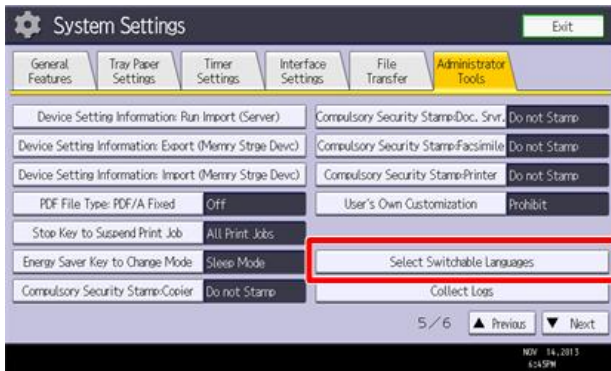

d191z5024

5. Press the "Select Switchable Language" button.

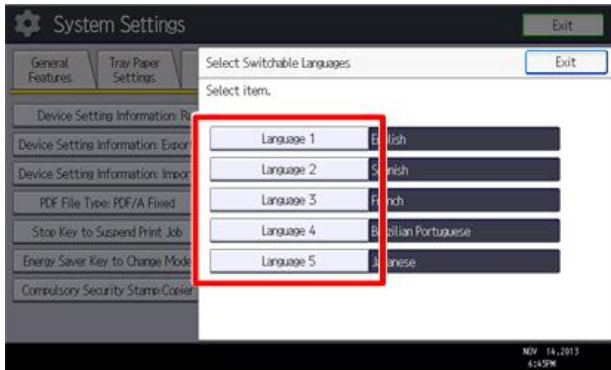

d191z5025

6. Press the "Language" button which you want to change.

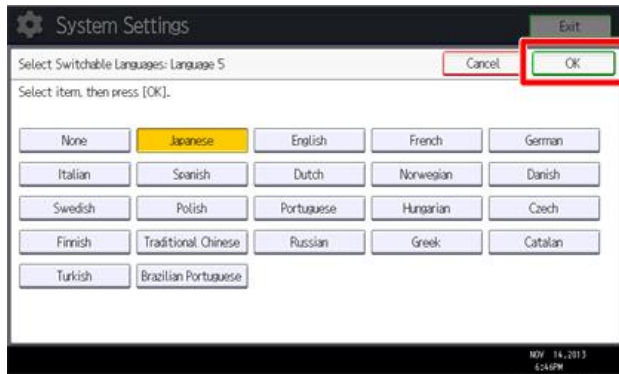

d191z5026

7. Press a language which you want to change, and then press "OK" button.
8. Go back to the top screen of the "User Tools/Counter/Inquiry".





d191z5027

9. Press the language selection button [A] to change a language which you have set before.
 - The displayed language is switched as the language selection button is pressed. (Language 1 > 2 > 3> 4 >5 > 1 > 2....)

Reboot/System Setting Reset

Software Reset

You can reboot the software with one of the following two procedures:



1. Turn the main power switch off and on.
2. Press and hold down  and  together for over 10 seconds. When the machine beeps once, release both buttons. After "Now loading. Please wait" shows for a few seconds, the copy window will open. The machine is ready for normal operation.

System Settings and Copy Setting Reset

5

System Setting Reset

The system settings in the UP mode can be reset to their defaults. Use the following procedure.

1. Press User Tools/Counter /123.
2. Hold down  and then press System Settings.

↓ Note

- You must press  first.

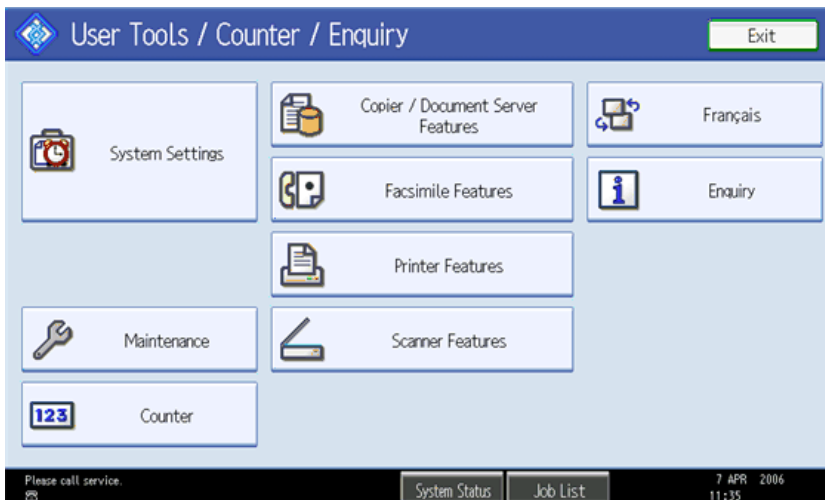

3. Press yes when the message prompts you to confirm that you want to reset the system settings.
4. Press exit when the message tells you that the settings have been reset.

Copier Setting Reset

Use the following procedure to reset the copy settings in the UP mode to their defaults.

1. Press User Tools/Counter 
2. Hold down  and then press Copier/Document Server Settings.

Note

- You must press  first.

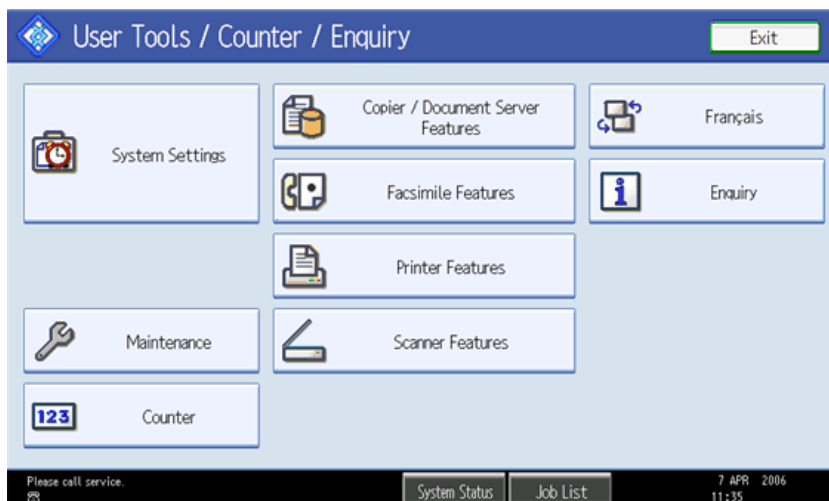

3. Press "Yes" when the message prompts you to confirm that you want to reset the Copier Document Server settings.
4. Press exit when the message tells you that the settings have been reset.

Controller Self-Diagnostics

Overview

There are three types of self-diagnostics for the controller.

1. Power-on self-diagnostics: The machine automatically starts the self-diagnostics just after the power has been turned on.
2. SC detection: The machine automatically detects SC conditions at power-on or during operation.

The following shows the workflow of the power-on and detailed self-diagnostics.

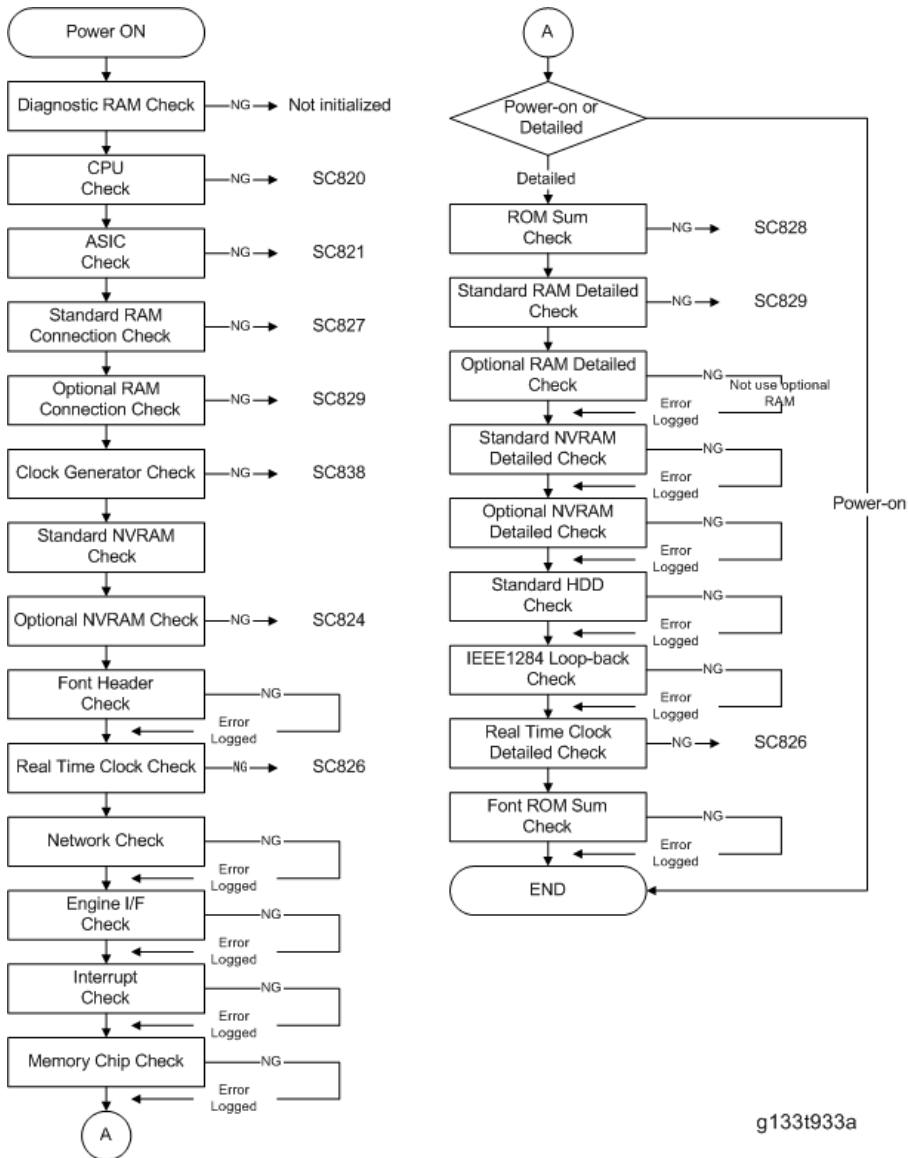

g133t933a

Downloading Stamp Data

The stamp data should be downloaded from the controller firmware to the hard disks at the following times:

- After the hard disks have been replaced.

The print data contains the controller software. Execute SP 5853 to download the fixed stamp data required by the hard disks.

1. Enter the SP mode.
2. Select SP5853 and then press "EXECUTE". The following screen opens while the stamp data is downloading.

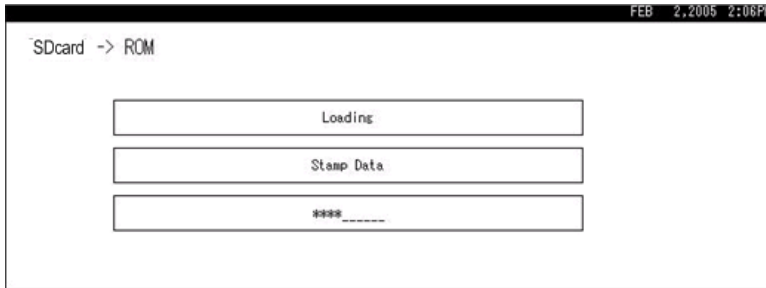

The download is finished when the message prompts you to close.



3. Press the "Exit" button. Then turn the copier off and on again.

NVRAM Data Upload/Download

Uploading Content of NVRAM to an SD card

Do the following procedure to upload SP code settings from NVRAM to an SD card.

↓ Note

- This data should always be uploaded to an SD card before the NVRAM is replaced.
 - Make sure that the write protection of an SD card is unlocked.
1. Do SP5990-001 (SMC Print) before you switch the machine off. You will need a record of the NVRAM settings if the upload fails.
 2. Switch the copier main power switch off.
 3. Remove the SD slot cover (🔑 x 1).
 4. Insert the SD card into SD card slot 2. Then switch the copier on.
 5. Execute SP5824-001 (NVRAM Data Upload) and then press the "Execute" key.
 6. The following files are copied to an NVRAM folder on the SD card when the upload procedure is finished. The file is saved to the path and the following filename:

NVRAM\<serial number>.NV

Here is an example with Serial Number "K5000017114":

NVRAM\K5000017114.NV

7. In order to prevent an error during the download, be sure to mark the SD card that holds the uploaded data with the number of the machine from which the data was uploaded.

↓ Note

- You can upload NVRAM data from more than one machine to the same SD card.

Downloading an SD Card to NVRAM

Do the following procedure to download SP data from an SD card to the NVRAM in the machine.

- The NVRAM data download may fail if the SD card with the NVRAM data is damaged, or if the connection between the controller and BCU is defective.
 - Do the download procedure again if the download fails.
 - Do the following procedure if the second attempt fails:
 - Enter the NVRAM data manually using the SMC print you created before uploading the NVRAM data.
1. Switch the copier main power switch off.

2. Remove the SD slot cover (🔧 x 1).
3. Insert the SD card with the NVRAM data into SD Card Slot 2.
4. Switch the copier main power switch on.
5. Do SP5825-001 (NVRAM Data Download) and press the "Execute" key.

Note

- The serial number of the file on the SD card must match the serial number of the machine for the NVRAM data to download successfully. The download fails if the serial numbers do not match.

This procedure does not download the following data to the NVRAM:

- Total Count
- C/O, P/O Count

Address Book Upload/Download

Information List

The following information is possible to be uploaded and downloaded.

Information	
<ul style="list-style-type: none"> • Registration No. • User Code • E-mail • Protection Code • Fax Destination • Fax Option • Group Name • Key Display 	<ul style="list-style-type: none"> • Select Title • Folder • Local Authentication • Folder Authentication • Account ACL • New Document Initial ACL • LDAP Authentication

5

Download

1. Prepare a formatted SD card.
2. Make sure that the write-protection on the SD card is off.
3. Turn off the main power switch of the main machine.
4. Remove the SD slot cover at the left rear side of the machine (🔧 x 1).
5. Install the SD card into the SD card slot 2 (for service use).
6. Turn on the main power switch.
7. Enter the SP mode.
8. Do SP5-846-051 (Backup All Addr Book).
9. Exit the SP mode, and then turn off the main power switch.
10. Remove the SD card from the SD card slot 2.
11. Install the SD slot cover.

⬇️ Note

- If the capacity of SD card is not enough to store the local user information, an error message is displayed.
- Carefully handle the SD card, which contains user information. Do not take it back to your location.

Upload

1. Turn off the main power switch of the main machine.
2. Remove the SD slot cover at the left rear side of the machine (🔧 x 1).
3. Install the SD card, which has already been uploaded, into the SD card slot 2.
4. Turn on the main power switch.
5. Enter the SP mode.
6. Do SP5-846-052 (Restore All Addr Book).
7. Exit the SP mode, and then turn off the main power switch.
8. Remove the SD card from the SD card slot 2.
9. Install the SD slot cover.

 **Note**

- The counter in the user code information is initialized after uploading.
- The information of an administrator and supervisor cannot be downloaded nor uploaded.
- If there is no data of address book information in the SD card, an error message is displayed.

Capturing the Debug Logs

Overview

With this feature, you can save debug logs that are stored in the machine (HDD or operation panel) on an SD card. This function allows the Customer Engineer to save and retrieve error information for analysis. The Capturing Log feature saves debug logs for:

- Controller
- Engine
- Operation panel

★ Important

- In older models, a technician enabled the logging tool after a problem occurred. After that, when the problem had been reproduced, the technician was able to retrieve the debug log.
- However, this new feature saves the debug logs whenever a problem occurs, and then this log can be saved to an SD card.
- You can retrieve the debug logs with an SD card without a network.
- Analysis of the debug log is effective for problems caused by the software. Analysis of the debug log is not valid for the selection of defective parts or problems caused by hardware.

5

Types of debug logs that can be saved

Type	Storage Timing	Destination (maximum storage capacity)
Controller debug log (GW debug log)	<ul style="list-style-type: none"> • Saved at all times 	HDD (4 GB). Compressed when written to an SD card from the HDD (from 4 GB to about 300 MB)
Engine debug log	<ul style="list-style-type: none"> • When an engine SC occurs • When paper feeding/output stop by jams • When the machine doors are opened during normal operation 	HDD (Up to 300 times)

Type	Storage Timing	Destination (maximum storage capacity)
Operation panel debug log	<ul style="list-style-type: none"> • When a controller SC occurs • When saving by manual operation with the Number keys and the Reset key (Press "Reset", "0", "1" and "C" (hold for 3 seconds)) • When the operation unit detects an error • When the operation panel detects an error 	<p>Operation panel (400 MB /Up to 30 times)</p> <p>When updating the firmware for the operation panel, the debug logs are erased.</p>

5

Debug logs are not saved when:

- Memory is being erased
- Data encryption equipment is being installed
- Firmware configuration is being changed
- There is a power outage (power cord disconnected accidentally).
- The machine is shut down normally but data write to the HDD cannot be completed. For example, when shutdown starts immediately after a paper jam, or when the front door is opened and closed, the machine needs about 5 sec. to save the debug log after the machine stops completely.
- Power supply to the HDD is off because of energy saving (engine OFF mode /STR mode)

Operation Log Security

The following operation logs related to security are never saved.

- User ID
- Password
- IP address
- Telephone number
- Encryption key
- Transition to SP mode

The following operation logs are never saved.

- Number keys (0 to 9) on the operation panel
- Soft keyboard on the touch panel display
- External keyboard

Retrieving Debug Logs

Retrieve debug logs to identify the date of occurrence and details about problems.

- Analysis of the debug log is effective for problems caused by the software.
- Analysis of the debug log cannot identify defects in parts or problems caused by hardware.

Procedure for Retrieving the Debug Log



d191b0071

1. Insert the SD card into the slot on the side of the operation panel.
2. Enter SP mode.
3. Set the start date of the log with **SP5857-101**.
 - Enter the date in the format `yyyymmdd` where `yyyy` is the year, `mm` the month, and `dd` the day.
 - For example, for March 28, 2013 you would enter "20130328"
 - Enter a date 72 hours before the problem occurred.
4. Set the end date of the log with **SP5857-102**.
 - Use the same format (`yyyymmdd`) that you used to enter the start date.
 - For example, for March 31, 2013 you would enter "20130331".
5. Next, do **SP5-857-103** to retrieve the debug log data and store it onto the SD card.
6. When the transfer is finished, the machine will display "Completed" on the operation panel.

★ Important

- The length of time needed to transfer the debug log data can be affected by the type and format of the SD card. Formatting the SD card with Panasonic SD Formatter (freeware) is recommended.

The approximate time required for the transfer of the following debug logs are:

- Controller (GW): 2 to 20 min.
- Engine debut log: 2 min.
- Operation: 2 to 20 minutes

7. Make sure that the SD card access LED is off, then remove the SD card.

If you see the "Failed" message, remove the SD card, cycle the machine off/on, and then repeat this procedure from Step 2.

Debug logs are saved with the following file names.

Debug Log	Filename Format
Controller(GW)	/LogTrace/machine no./watching/yyyymmdd_hhmmss_unique ID.gz
Engine	/LogTrace/machine number/engine/yyyymmddhhmmss.gz
Operation Panel	/LogTrace/machine no./opepanel/yyyymmdd_hhmmss.tar.gz

Card Save Function

Overview

Card Save:

- The Card Save function is used to save print jobs received by the printer on an SD card with no print output. Card Save mode is toggled using printer Bit Switch #1 bit number 4. Card Save will remain enabled until the SD card becomes full, or until all file names have been used.
- Captures are stored on the SD card in the folder /prt/cardsave. File names are assigned sequentially from PRT00000.prn to PRT99999.prn. An additional file PRT.CTL will be created. This file contains a list of all files created on the card by the card save function.
- Previously stored files on the SD card can be overwritten or left intact. Card Save SD has "Add" and "New" menu items.
 - **Card Save (Add):** Appends files to the SD Card. Does not overwrite existing files. If the card becomes full or if all file names are used, an error will be displayed on the operation panel. Subsequent jobs will not be stored.
 - **Card Save (New):** Overwrites files in the card's /prt/cardsave directory.

Limitation:

- Card Save cannot be used with PjL Status Readback commands. PjL Status Readbacks will not work. In addition they will cause the Card Save to fail.

Procedure

1. Turn the main power switch OFF.
2. Insert the SD card into slot 2. Then turn the power ON.
3. Enter SP mode.
4. Select the "Printer SP".
5. Select SP-1001 "Bit Switch".

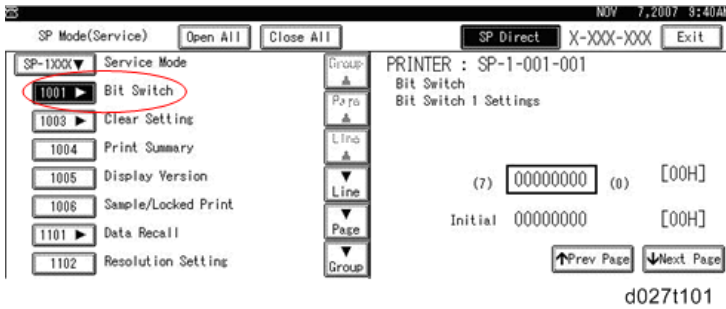

6. Select "Bit Switch 1 Settings" and use the numeric keypad to turn bit 4 ON and then press the "#" button to register the change. The result should look like: **00010000**. By doing this, Card Save option will appear in the "List/Test Print" menu.

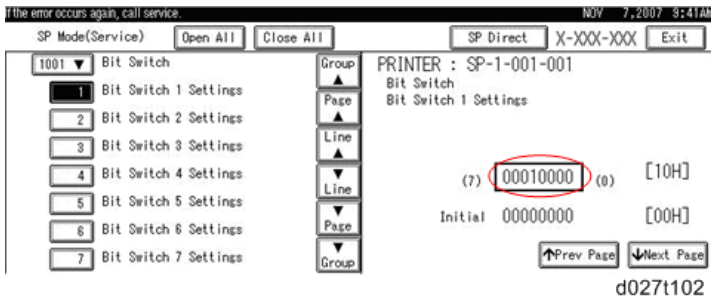

7. Press "Exit" to exit SP Mode.
8. Press the "User Tools/Counter" button.

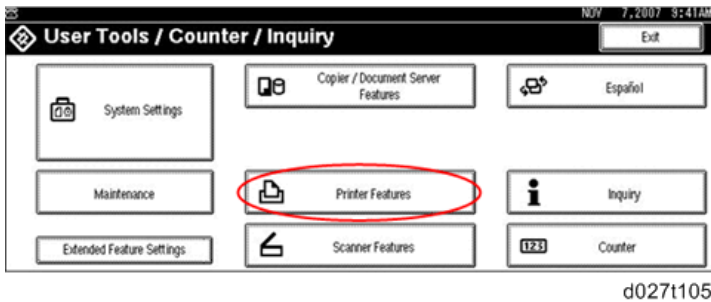

9. Select "Printer Features".

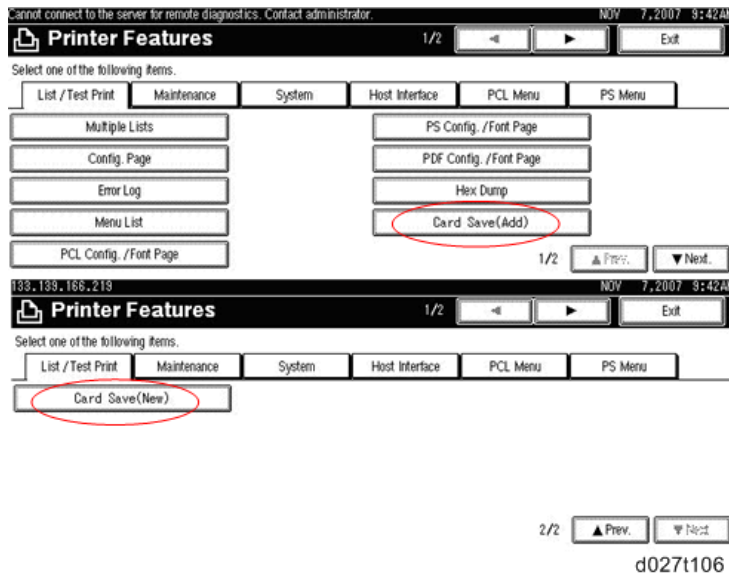

10. Card Save (Add) and Card Save (New) should be displayed on the screen. Select Card Save (Add) or Card Save (New).

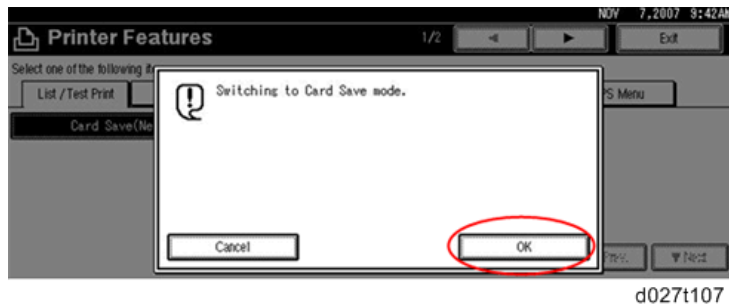

11. Press "OK" and then exit the "User Tools/Counter" menu.
12. Press the "Printer" button.

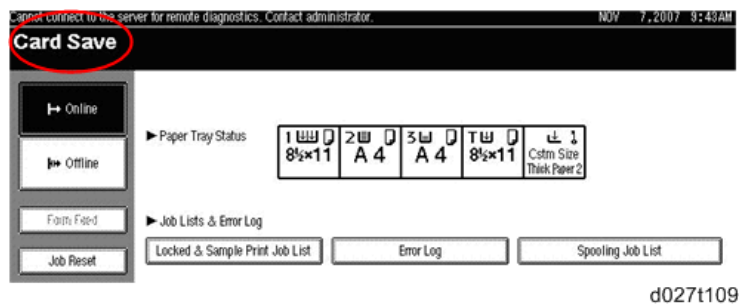

13. Card Save should be displayed in the top left of the display panel.
14. Send a job to the printer. The Communicating light should start blinking.

15. As soon as the printer receives the data, it will be stored on the SD card automatically with no print output. Nothing is displayed on the screen, indicating that a Card Save operation was successful.

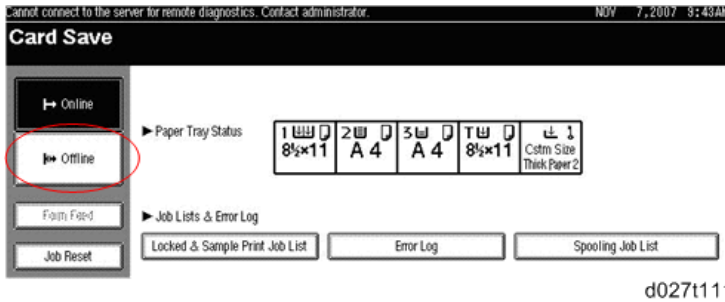

16. Press "Offline" and then the "Clear/Stop" button to exit Card Save mode.
17. Change the Bit Switch Settings back to the default 00000000. Press the "#" button in the numeric keypad to register the changes.
18. Remove the SD card after the main power switch is turned off.

5

Error Messages

Card Save error messages:

- **Init error:** A card save process (e.g. card detection, change to kernel mode) failed to initialize.
- **Card not found:** Card cannot be detected in the slot.
- **No memory:** Insufficient working memory to process the job.
- **Write error:** Failed to write to the card.
- **Other error:** An unknown error occurred.

If an error occurs, pressing "OK" will cause the device to discard the job and return to the ready state.

Test Pattern Printing

Printing Test pattern: SP2-109

Some of these test patterns are used for copy image adjustments but most are used primarily for design testing.

↓ Note

- Do not operate the machine until the test pattern is printed out completely. Otherwise, an SC occurs.
1. Enter the SP mode and select **SP2-109-003**.
 2. Enter the number for the test pattern that you want to print and press [#].
 3. When you want to select the single color of Magenta, Yellow or Cyan for printing a test pattern, select the color with SP2-109-005 (2: Magenta, 3: Yellow, 4: Cyan).
 4. When you want to change the density of printing a test pattern, select the density with SP2-109-006 to -009 for each color.

↓ Note

- If you select "0" with SP2-109-006 to -009, the color to be adjusted to "0" does not come up on a test pattern.
5. When you are prompted to confirm your selection, touch "Yes" to select the test pattern for printing.
 6. Touch "Copy Window" to open the copy window, then select the settings for the test print (paper size etc.).

↓ Note

- If you want to use black and white printing, touch "Black & White" on the LCD. If you want to use color printing, touch "Full Colour" on the LCD.
7. Press the "Start" key to start the test print.
 8. After checking the test pattern, touch "SP Mode" on the LCD to return to the SP mode display.
 9. Reset all settings to the default values.
 10. Touch "Exit" twice to exit SP mode.

No.	Pattern	No.	Pattern
0	None	12	Independent Pattern (2-dot)
1	Vertical Line (1 dot)	13	Independent Pattern (4-dot)
2	Vertical Line (2dot)	14	Triming Area
3	Horizontal Line (1 dot)	15	Hound's Tooth Check (Vertical)

4	Horizontal Line (2dot)	16	Hound's Tooth Check (Horizontal)
5	Grid Vertical Line	17	Band (Horizontal)
6	Grid Horizontal Line	18	Band (Vertical)
7	Grid Pattern Small	19	Checker Flag Pattern
8	Grid Pattern Large	20	Grayscale (Vertical Margin)
9	Argyle Pattern Small	21	Grayscale (Horizontal Margin)
10	Argyle Pattern Large	22	Two Beam Density Pattern
11	Independent Pattern (1-dot)	23	Full Dot Pattern

6. Troubleshooting

SC Tables

Service Call Conditions

Summary

The 'SC Table' section shows the SC codes for controller errors and other errors. The latter (not controller errors) are put into four types. The type is determined by their reset procedures. The table shows the classification of the SC codes.

	Key	Definition	Reset Procedure
Controller errors	CTL	The error has occurred in the controller.	See "Troubleshooting Procedure" in the table.
Other errors	A	The error involves the fusing unit. The machine operation is disabled. The user cannot reset the error.	Turn the main switch off and on. Reset the SC (set SP5-810-1). Turn the main switch off and on.
	B	The error involves one or some specific units. The machine operates as usual, excluding the related units.	Turn the operation switch off and on.
	C	The error is logged. The SC-code history is updated. The machine operates as usual.	The SC will not show. Only the SC history is updated.
	D	The machine operation is disabled. You can reset the machine by turning the operation switch or main switch off and on. If the error occurs again, the same SC code is displayed.	Turn the operation switch or main power switch off and on.

After you turn the main power switch off, wait for one second or more before you turn the main power switch on (SC 672). All SCs are logged. The print log data (SP5-990-004) in SP mode can check the latest 10 SC codes detected and total counters when the SC code is detected.

↓ Note

- If the problem concerns electrical circuit boards, first disconnect then reconnect the connectors before you replace the PCBs.
- If the problem concerns a motor lock, first check the mechanical load before you replace motors or sensors.

SC Code Classification

The table shows the classification of the SC codes:

Class 1	Section	SC Code	Detailed section
1XX	Scanning	100 -	Scanner
		190 -	Unique for a specific model
2XX	Laser exposure	200 -	Polygon motor
		220 -	Synchronization control
		230 -	FGATE signal related
		240 -	LD control
		280 -	Unique for a specific model
		290 -	Shutter
3XX	Image development 1	300 -	Charge
		330 -	Drum potential
		350 -	Development
		380 -	Unique for a specific model
4XX	Image development 2	400 -	Image transfer
		420 -	Paper separation
		430 -	Cleaning
		440 -	Around drum
		460 -	Unit
		480 -	Others

Class 1	Section	SC Code	Detailed section
5XX	Paper feed / Fusing	500 -	Paper feed
		515 -	Duplex
		520 -	Paper transport
5XX	Paper feed / Fusing	530 -	Fan motor
		540 -	Fusing
		560 -	Others
		570 -	Unique for a specific model
6XX	Communication	600 -	Electrical counters
		620 -	Mechanical counters
		630 -	Account control
		640 -	CSS
		650 -	Network
		670 -	Internal data processing
		680 -	Unique for a specific model
7XX	Peripherals	700 -	Original handling
		720 -	Two-tray finisher
		740 -	Booklet finisher
8XX	Controller	800 -	Error after ready condition
		820 -	Diagnostics error
		860 -	Hard disk
		880 -	Unique for a specific model
9XX	Others	900 -	Counter
		920 -	Memory
		990 -	Others

Service Call 1xx

SC1xx: Scanning

No.	Type	Details (Symptom, Possible Cause, Troubleshooting)
101	D	LED lamp error
		The peak white level is less or more than 64/255 digits (8 bits) when scanning the shading plate.
		<ul style="list-style-type: none"> • LED board defective • IDB defective • Harness connection between LED board and IDB disconnected • Standard white plate dirty • Scanner mirror or scanner lens out of position or dirty • SBU, IPU or BCU defective
		<ul style="list-style-type: none"> • Check and clean the scanner mirror(s) and scanner lens. • Check and clean the shading plate. • Check the cable connection between the LED board and IDB. • Replace the LED board. • Replace the IDB. • Replace the SBU, IPU or BCU.

No.	Type	Details (Symptom, Possible Cause, Troubleshooting)
120	D	Scanner home position error 1
		The scanner home position sensor does not detect the "OFF" condition during operation.
		<ul style="list-style-type: none"> • Scanner motor driver defective • Scanner motor defective • Harness between IPU and scanner motor disconnected • Scanner HP sensor defective • Harness between IPU and HP sensor disconnected • IPU or BCU defective
		<ul style="list-style-type: none"> • Check the cable connections (IPU to scanner motor and IPU and scanner HP sensor). • Replace the scanner motor. • Replace the HP sensor. • Replace the IPU or BCU.

No.	Type	Details (Symptom, Possible Cause, Troubleshooting)
121	D	Scanner home position error 2
		The scanner home position sensor does not detect the "ON" condition during operation.
		<ul style="list-style-type: none"> • Scanner motor driver defective • Scanner motor defective • Harness between IPU and scanner motor disconnected • Scanner HP sensor defective • Harness between IPU and HP sensor disconnected • IPU or BCU defective
		<ul style="list-style-type: none"> • Check the cable connections (IPU to scanner motor and IPU and scanner HP sensor). • Replace the scanner motor. • Replace the HP sensor. • Replace the IPU or BCU.

No.	Type	Details (Symptom, Possible Cause, Troubleshooting)
141	D	Black level detection error
		The black level cannot be adjusted within the target value during the zero clamp.
		<ul style="list-style-type: none"> • Harness disconnected • IPU defective • SBU defective
		<ul style="list-style-type: none"> • Check the cable connection • Replace the IPU. • Replace the SBU.

No.	Type	Details (Symptom, Possible Cause, Troubleshooting)
142	D	White level detection error
		The white level cannot be adjusted within the target during auto gain control.
		<ul style="list-style-type: none"> • Dirty exposure glass or optics section • Harness between LED lamp and IDB disconnected • SBU defective • LED lamp defective • IDB defective • IPU defective
		<ul style="list-style-type: none"> • Clean the exposure glass, white plate, mirrors, and lens. • Check if the LED lamp is lit during initialization. • Check the harness connections (LED board to IDB, IDB to IPU and SBU to IPU). • Replace the LED board. • Replace the IDB. • Replace the SBU. • Replace the IPU.

No.	Type	Details (Symptom, Possible Cause, Troubleshooting)
144	D	SBU communication error
		The SBU connection cannot be detected at power on or recovery from the energy save mode.
		<ul style="list-style-type: none"> • Defective SBU • Defective harness • Defective detection port on the IPU • Defective detection port on the BCU
		<ul style="list-style-type: none"> • Replace the harness. • Replace the SBU. • Replace the IPU. • Replace the BCU.

No.	Type	Details (Symptom, Possible Cause, Troubleshooting)
161	D	IPU error
001		The error result of self-diagnostic by the ASIC on the IPU is detected.
		<ul style="list-style-type: none"> • Defective IPU • Defective connection between IPU and SBU
		<ol style="list-style-type: none"> 1. Check the connection between IPU and SBU. 2. Replace the IPU.
002	D	The machine detects an error during an access to the Ri.
		<ul style="list-style-type: none"> • Defective IPU
		Replace the IPU.

No.	Type	Details (Symptom, Possible Cause, Troubleshooting)
165	D	Copy Data Security Unit error
		<ul style="list-style-type: none"> The copy data security board is not detected when the copy data security function is set "ON" with the initial setting. A device check error occurs when the copy data security function is set "ON" with the initial setting.
		<ul style="list-style-type: none"> Incorrect installation of the copy data security board Defective copy data security board
		<ul style="list-style-type: none"> Reinstall the copy data security board. Replace the copy data security board.

No.	Type	Details (Symptom, Possible Cause, Troubleshooting)
195	D	Serial Number Mismatch
		<ul style="list-style-type: none"> Serial number stored in the memory does not have the correct code.
		<ul style="list-style-type: none"> EEPROM defective BCU replaced without original EEPROM
		<ul style="list-style-type: none"> Check the serial number with SP5-811-002. If the stored serial number is incorrect, contact your supervisor.

Service Call 2xx

SC 2xx: Exposure

No.	Type	Details (Symptom, Possible Cause, Troubleshooting)
202	D	Polygon motor error 1: ON timeout
		The polygon mirror motor does not reach the targeted operating speed within the specified time after turning on or changing speed
		<ul style="list-style-type: none"> • Defective or disconnected harness to polygon motor driver board • Defective polygon motor driver board • Defective polygon motor • Defective IPU
		<ul style="list-style-type: none"> • Replace the laser unit. • Replace the harness. • Replace the IPU.

6

No.	Type	Details (Symptom, Possible Cause, Troubleshooting)
203	D	Polygon motor error 2: OFF timeout
		The polygon mirror motor does leave the READY status within 3 seconds after the polygon motor switches off.
		<ul style="list-style-type: none"> • Disconnected or defective harness to polygon motor driver board • Defective polygon motor driver board • Defective laser unit • Defective IPU
		<ul style="list-style-type: none"> • Check or replace the harness. • Replace the laser unit. • Replace the IPU.

No.	Type	Details (Symptom, Possible Cause, Troubleshooting)
204	D	Polygon motor error 3: XSCRDY signal error
		The SCRDY_N signal goes HIGH (inactive) while the laser diode is firing.
		<ul style="list-style-type: none"> • Disconnected or defective harness to polygon motor driver board • Defective polygon motor • Defective polygon motor driver board • Defective IPU
		<ul style="list-style-type: none"> • Check or replace the harness. • Replace the laser unit. • Replace the IPU

No.	Type	Details (Symptom, Possible Cause, Troubleshooting)
220-01	D	Laser synchronizing detection error: start position [K]: LD0
-04	D	Laser synchronizing detection error: start position [Y]: LD0
-	-	<p>The laser synchronizing detection signal for the start position of the LDB [K], [Y] is not output for two seconds after LDB unit turns on while the polygon motor is rotating normally.</p> <ul style="list-style-type: none"> • Disconnected cable from the laser synchronizing detection unit or defective connection • Defective laser synchronizing detector • Defective LDB • Defective IPU <ul style="list-style-type: none"> • Check the connectors. • Replace the laser unit. • Replace the IPU.

No.	Type	Details (Symptom, Possible Cause, Troubleshooting)
230 -01	D	FGATE ON error: K
		The PFGATE ON signal does not assert within 5 seconds after processing the image in normal job or MUSIC for start position [K].
		<ul style="list-style-type: none"> • Poor connection between controller and IPU. • Defective IPU
		<ul style="list-style-type: none"> • Check the connection between the controller board and the IPU. • Replace the IPU.

No.	Type	Details (Symptom, Possible Cause, Troubleshooting)
230 -02	D	FGATE ON error: C
		The PFGATE ON signal does not assert within 5 seconds after processing the image in normal job or MUSIC for start position [C].
		<ul style="list-style-type: none"> • Check the connection between the controller board and the IPU. • Replace the IPU.

No.	Type	Details (Symptom, Possible Cause, Troubleshooting)
230 -03	D	FGATE ON error: M
		The PFGATE ON signal does not assert within 5 seconds after processing the image in normal job or MUSIC for start position [M].
		<ul style="list-style-type: none"> • Check the connection between the controller board and the IPU. • Replace the IPU.

No.	Type	Details (Symptom, Possible Cause, Troubleshooting)
230 -04	D	FGATE ON error: Y
		The PFGATE ON signal does not assert within 5 seconds after processing the image in normal job or MUSIC for start position [Y].
		<ul style="list-style-type: none"> • Check the connection between the controller board and the IPU. • Replace the IPU.

No.	Type	Details (Symptom, Possible Cause, Troubleshooting)
231 -01	D	FGATE OFF error: K
		<ul style="list-style-type: none"> • The PFGATE ON signal still asserts within 5 seconds after processing the image in normal job or MUSIC for end position [K]. • The PFGATE ON signal still asserts when the next job starts.
		<ul style="list-style-type: none"> • Check the connection between the controller board and the IPU. • Replace the IPU.

No.	Type	Details (Symptom, Possible Cause, Troubleshooting)
231 -02	D	FGATE OFF error: C
		<ul style="list-style-type: none"> • The PFGATE ON signal still asserts within 5 seconds after processing the image in normal job or MUSIC for end position [C]. • The PFGATE ON signal still asserts when the next job starts.
		<ul style="list-style-type: none"> • Check the connection between the controller board and the IPU. • Replace the IPU.

No.	Type	Details (Symptom, Possible Cause, Troubleshooting)
231 -03	D	FGATE OFF error: M
		<ul style="list-style-type: none"> • The PFGATE ON signal still asserts within 5 seconds after processing the image in normal job or MUSIC for end position [M]. • The PFGATE ON signal still asserts when the next job starts.
		<ul style="list-style-type: none"> • Check the connection between the controller board and the IPU. • Replace the IPU.

No.	Type	Details (Symptom, Possible Cause, Troubleshooting)
231 -04	D	FGATE OFF error: Y
		<ul style="list-style-type: none"> The PFGATE ON signal still asserts within 5 seconds after processing the image in normal job or MUSIC for end position [Y]. The PFGATE ON signal still asserts when the next job starts.
		<ul style="list-style-type: none"> Check the connection between the controller board and the IPU. Replace the IPU.

No.	Type	Details (Symptom, Possible Cause, Troubleshooting)
240 -01	D	LD error: K or C
240 -04	D	LD error: Y or M
-	-	The IPU detects LDB error a few times consecutively when laser unit turns on after LDB initialization.
		<ul style="list-style-type: none"> Worn-out LD Disconnected or broken harness of the LDB Defective LDB Defective IPU
		<ul style="list-style-type: none"> Replace the harness of the laser unit. Replace the laser unit. Replace the IPU.

No.	Type	Details (Symptom, Possible Cause, Troubleshooting)
270	D	Write ASIC communication error
		<ul style="list-style-type: none"> • Write/read values were checked twice but failed to match. • Parity error resulted after three attempts.
		<ul style="list-style-type: none"> • Cycle the machine off/on. • Harness between OPU and BCU loose, broken, defective • IPU defective • BCU defective

No.	Type	Details (Symptom, Possible Cause, Troubleshooting)
285	C	Line position adjustment (MUSIC) error
		Line position adjustment fails four consecutive times.
		<ul style="list-style-type: none"> • Pattern sampling error (insufficient image density) • Defective ID sensors for the line position adjustment • Defective image transfer belt unit • Defective PCDU(s) • Defective laser unit
		<ul style="list-style-type: none"> • Check and reinstall the image transfer belt unit and PCDUs. • Check if each toner bottle has enough toner. • Replace the ID sensor. • Replace the image transfer belt unit. • Replace the PCDU(s). • Replace the laser unit.

Service Call 3xx

SC3xx: Image Processing – 1

No.	Type	Details (Symptom, Possible Cause, Troubleshooting)
312	D	Charge P.P. output error [K]
313	D	Charge P.P. output error [M]
314	D	Charge P.P. output error [C]
315	D	Charge P.P. output error [Y]
-	-	<p>The feedback voltage of the charge AC for each color is 0.3 V or less for 0.2 seconds after the charge AC has turned on.</p> <ul style="list-style-type: none"> • Disconnected or broken harnesses of the HVPS: CB board • Defective PCDU • Defective HVPS <p>• Do the troubleshooting for "PCDU Installation (SC312, SC313, SC314, SC315)" (page 962).</p> <ul style="list-style-type: none"> • Check or replace the harnesses of the HVPS: CB board. • Reinstall or replace the PCDU. • Replace the HVPS: CB board.

No.	Type	Details (Symptom, Possible Cause, Troubleshooting)
325	D	Color development motor error
		The motor LOCK signal is not detected for more than two seconds while the motor START signal is on.
		<ul style="list-style-type: none"> • Color development motor slip due to an increase in the torque caused by connected components. • Defective motor.
		<ul style="list-style-type: none"> • Adjust the torque properly by replacing or cleaning the PCDU. • Replace the PCDU. • Replace the development motor: CMY if load torque is normal.

SC3xx: Image Processing – 2

No.	Type	Details (Symptom, Possible Cause, Troubleshooting)
360	D	TD sensor (Vt high) error 1: K
361	D	TD sensor (Vt high) error 1: M
362	D	TD sensor (Vt high) error 1: C
363	D	TD sensor (Vt high) error 1: Y
-	-	<ul style="list-style-type: none"> • The Vt value of the black, magenta, cyan, or yellow TD sensor exceeds the specified value (default: 4.7V) with SP3020-002 for twenty counts. • The [Vt - Vtref] value of the black, magenta, cyan, or yellow TD sensor exceeds the specified value (default: 5.0V) with SP3020-001.
		<ul style="list-style-type: none"> • Black, magenta, cyan, or yellow TD sensor disconnected • Harness between TD sensor and PCDU defective • Defective TD sensor.
		<ul style="list-style-type: none"> • Check the drawer connector. • Do the troubleshooting for “Light Density (SC360, SC361, SC362, SC363)” (page 958). • Replace the defective PCDU.

No.	Type	Details (Symptom, Possible Cause, Troubleshooting)
364	D	TD sensor (Vt low) error 2: K
365	D	TD sensor (Vt low) error 2: M
366	D	TD sensor (Vt low) error 2: C
367	D	TD sensor (Vt low) error 2: Y

No.	Type	Details (Symptom, Possible Cause, Troubleshooting)
-	-	<p>The Vt value of the black, magenta, cyan, or yellow TD sensor is below the specified value with SP3020-004 (default: 0.5V) for 10 counts.</p> <ul style="list-style-type: none"> • TD sensor harness disconnected, loose, defective • A drawer connector disconnected, loose, defective • TD sensor defective <ul style="list-style-type: none"> • Check the drawer connector. • Replace the defective PCDU.

No.	Type	Details (Symptom, Possible Cause, Troubleshooting)
372	D	TD sensor adjustment error: K
373	D	TD sensor adjustment error: M
374	D	TD sensor adjustment error: C
375	D	TD sensor adjustment error: Y
-	-	<p>During TD sensor initialization, the output value of the black, magenta, cyan, or yellow TD sensor is not within the range of the specified value with SP3238-001 to -004 (default: 2.5V) \pm 0.2V</p> <ul style="list-style-type: none"> • Heat seal not removed from a new developer pack • TD harness sensor disconnected, loose or defective • TD sensor defective • Harness between TD sensor and drawer disconnected, defective <ul style="list-style-type: none"> • Remove the heat seal from each PCDU. • Replace the defective PCDU.

No.	Type	Details (Symptom, Possible Cause, Troubleshooting)
380	C	Drum gear position sensor error: K
381	C	Drum gear position sensor error: CMY

No.	Type	Details (Symptom, Possible Cause, Troubleshooting)
		The machine does not detect the drum position signal for 3 seconds at the drum phase adjustment.
		<ul style="list-style-type: none"> • Dirty or defective drum gear position sensor
		<ul style="list-style-type: none"> • Clean the drum gear position sensor. • Check the harness connection. • Replace the drum gear position sensor.

No.	Type	Details (Symptom, Possible Cause, Troubleshooting)
396	D	Drum/Development motor error: K
397	D	Drum motor error: CMY
-	-	The machine detects a High signal from the drum/development motor for 2 seconds after the drum/development motor turned on.
		<ul style="list-style-type: none"> • Overload on the drum/development motor • Defective drum/development motor • Defective harness • Shorted 24 V fuse on the PSU • Defective interlock system
		<ul style="list-style-type: none"> • Check or replace the harness. • Replace the drum/development motor. • Replace the 24V fuse on the PSU.

Service Call 4xx

SC4xx: Image Processing - 3

No.	Type	Details (Symptom, Possible Cause, Troubleshooting)
400	D	ID sensor adjustment error
		When the Vsg error counter reaches "3", the machine detects "SC400". The Vsg error counter counts "1" when the Vsg detected by ID sensor is more than the value (default: 4.5V) specified with SP3324-005 or less than the value (default: 3.5V) specified with SP3324-006.
		<ul style="list-style-type: none"> • Dirty or defective ID sensor • Defective ID sensor shutter
		<ul style="list-style-type: none"> • Check the harness of the ID sensor. • Clean or replace the ID sensor. <p>Note</p> <ul style="list-style-type: none"> • After replacing the ID sensor, input the ID sensor correction coefficient with SP3362-013 to -018. For details, refer to "ID sensor board" in the Replacement and Adjustment section. <ul style="list-style-type: none"> • Replace the BCU. • Replace the image transfer belt unit.

No.	Type	Details (Symptom, Possible Cause, Troubleshooting)
442	D	Image transfer belt contact motor error
		The image transfer belt contact sensor does not detect the movement of actuator at the sensor while the polygon motor rotates.
		<ul style="list-style-type: none"> • Dirty image transfer belt contact sensor • Defective image transfer belt contact motor • Disconnected connector of image transfer belt contact sensor or motor • Disconnected cable • Broken +24V fuse on PSU • Defective interlock switches • Defective BCU
		<ul style="list-style-type: none"> • Replace the image transfer belt contact sensor. • Replace the image transfer belt contact motor. • Replace the +24V fuse on the PSU. • Replace the interlock switches. • Replace the BCU.

No.	Type	Details (Symptom, Possible Cause, Troubleshooting)
443	C	Image transfer unit error
		The machine detects the encoder sensor error.
		<ul style="list-style-type: none"> • Defective encoder sensor • Image transfer unit installation error • Defective image transfer unit motor
		<ul style="list-style-type: none"> • Check if the image transfer unit is correctly set. • Replace the image transfer unit motor. • Replace the image transfer unit.

No.	Type	Details (Symptom, Possible Cause, Troubleshooting)
452	D	Paper transfer unit contact error
		The paper transfer unit contact sensor does not detect the movement of actuator at the sensor while the polygon motor rotates.
		<ul style="list-style-type: none"> • Defective paper transfer unit contact sensor • Defective paper transfer unit contact motor • Broken +24V fuse on PSU • Defective BCU
		<ul style="list-style-type: none"> • Check the connection between the paper transfer unit and PSU. • Replace the paper transfer unit contact sensor. • Replace the paper transfer unit contact motor. • Replace the +24V fuse on the PSU. • Replace the BCU.

No.	Type	Details (Symptom, Possible Cause, Troubleshooting)
460	D	Separation power pack output error
		An interrupt checks the status of the power pack every 20 ms. This SC is issued if the BCU detects a short in the power pack 10 times at D(ac).
		<ul style="list-style-type: none"> • Damaged insulation on the HVPS: D cable • Damaged insulation around the HVPS: D.
		<ul style="list-style-type: none"> • Replace the HVPS: D cable. • Replace the HVPS: D.

No.	Type	Details (Symptom, Possible Cause, Troubleshooting)
491	D	High voltage power: Drum/ development bias output error
		An error signal is detected for 0.2 seconds when charging the drum or development.
		<ul style="list-style-type: none"> • High voltage leak • Broken harness • Defective drum unit or development unit • Defective HVPS: CB
		<ul style="list-style-type: none"> • Check or replace the harness. • Replace the drum unit or paper transfer unit. • Replace the HVPS: CB.

No.	Type	Details (Symptom, Possible Cause, Troubleshooting)
492	C	High voltage power: Image transfer/ paper transfer bias output error
		An error signal is detected for 0.2 seconds when charging the separation, image transfer bet or paper transfer roller.
		<ul style="list-style-type: none"> • High voltage open • Broken harness • Defective image transfer belt unit or paper transfer unit • Defective HVPS: T1T2
		<ul style="list-style-type: none"> • Check or replace the harness. • Replace the image transfer belt unit or paper transfer unit. • Replace the HVPS: T1T2.

No.	Type	Details (Symptom, Possible Cause, Troubleshooting)
495	D	Toner collection motor error
		The machine detects that the toner collection bottle is not set for one second when the toner collection motor is turned off.
		<ul style="list-style-type: none"> • Toner collection motor damaged • Disconnect or defective harness
		<ul style="list-style-type: none"> • Check or replace the harness. • Replace the toner collection motor. • Check and retry the connecting procedure.

No.	Type	Details (Symptom, Possible Cause, Troubleshooting)
498	C	Temperature and humidity sensor error
		<ul style="list-style-type: none"> • The thermistor output of the temperature sensor was not within the prescribed range (0.5V to 2.8V). • The thermistor output of the humidity sensor was not within the prescribed range (0.01V to 2.4V).
		<ul style="list-style-type: none"> • Temperature and humidity sensor harness disconnected, loose, defective • Temperature and humidity sensor defective
		<ul style="list-style-type: none"> • Check the connector and harness. • Replace the temperature/humidity sensor.

Service Call 5xx

SC5xx: Paper Feed and Fusing

No.	Type	Details (Symptom, Possible Cause, Troubleshooting)
501	B	1st paper tray lift motor malfunction
502	B	2nd paper tray lift motor malfunction (optional paper feed unit)
503	B	3rd paper tray lift motor malfunction (optional paper feed unit)
504	B	4th paper tray lift motor malfunction (optional paper feed unit)
-	-	<p>The paper lift sensor did not activate within 10 sec. after the tray lift motor switched on.</p> <ul style="list-style-type: none"> • An obstruction (jammed paper, paper scraps, etc.) has blocked the motor drive and caused an overload. • Paper lift sensor connection loose, disconnected, or damaged • Paper lift sensor defective • Tray lift motor connection loose, disconnected, or damaged • Tray lift motor defective <ul style="list-style-type: none"> • Check or replace the harness. • Replace the tray lift motor. • Replace the BCU.

No.	Type	Details (Symptom, Possible Cause, Troubleshooting)
530	D	Ventilation fan 1 error
531	D	Ventilation fan 2 error

No.	Type	Details (Symptom, Possible Cause, Troubleshooting)
		The motor lock signal error is detected for 10 seconds after the motor lock signal was first detected.
		<ul style="list-style-type: none"> • Defective ventilation fan 1 or development fan 2 • Disconnected or defective harness • Defective BCU
		<ul style="list-style-type: none"> • Check or replace the harness. • Replace the ventilation fan 1 (SC530) or ventilation fan 2 (SC531). • Replace the BCU.

No.	Type	Details (Symptom, Possible Cause, Troubleshooting)
		Laser unit fan error
		The motor lock signal error is detected for 10 seconds after the motor lock signal was first detected.
		<ul style="list-style-type: none"> • Defective laser unit fan • Disconnected or defective harness • Defective BCU
		<ul style="list-style-type: none"> • Check or replace the harness. • Replace the laser unit fan. • Replace the BCU.

No.	Type	Details (Symptom, Possible Cause, Troubleshooting)
533	D	Fusing front fan error
		The motor lock signal error is detected for 10 seconds after the motor lock signal was first detected.
		<ul style="list-style-type: none"> • Defective fusing front fan • Disconnected or defective harness • Defective BCU
		<ul style="list-style-type: none"> • Check or replace the harness. • Replace the fusing front fan. • Replace the BCU.

No.	Type	Details (Symptom, Possible Cause, Troubleshooting)
534	D	Fusing rear fan error
		The motor lock signal error is detected for 10 seconds after the motor lock signal was first detected.
		<ul style="list-style-type: none"> • Defective fusing rear fan • Disconnected or defective harness • Defective BCU
		<ul style="list-style-type: none"> • Check or replace the harness. • Replace the fusing rear fan. • Replace the BCU.

No.	Type	Details (Symptom, Possible Cause, Troubleshooting)
535	D	Drive unit fan error
		The motor lock signal error is detected for 10 seconds after the motor lock signal was first detected.
		<ul style="list-style-type: none"> • Defective drive unit fan • Disconnected or defective harness • Defective BCU
		<ul style="list-style-type: none"> • Check or replace the harness. • Replace the drive unit fan. • Replace the BCU.

No.	Type	Details (Symptom, Possible Cause, Troubleshooting)
536	D	Toner supply fan error
		The motor lock signal error is detected for 10 seconds after the motor lock signal was first detected.
		<ul style="list-style-type: none"> • Defective toner supply fan • Disconnected or defective harness • Defective BCU
		<ul style="list-style-type: none"> • Check or replace the harness. • Replace the toner supply fan. • Replace the BCU.

No.	Type	Details (Symptom, Possible Cause, Troubleshooting)
540	D	Fusing/Paper exit motor error
		The BCU does not receive the lock signal 2 seconds after turning on the fusing/paper exit motor.
		<ul style="list-style-type: none"> • Motor overload • Defective fusing/paper exit motor • Broken +24V fuse on PSU • Defective interlock switches
		<ul style="list-style-type: none"> • Check or replace the harness. • Replace the fusing/paper exit motor. • Replace the +24V fuse on PSU. • Replace the interlock switches.

No.	Type	Details (Symptom, Possible Cause, Troubleshooting)
541	A	Heating roller thermopile error
		The temperature detected by the heating roller thermopile does not reach 0°C for 6 seconds.
		<ul style="list-style-type: none"> • Loose connection of the heating roller thermopile • Defective heating roller thermopile • Defective thermopile
		<ul style="list-style-type: none"> • Check if the heating roller thermopile is firmly connected. • Replace the heating roller thermopile.

No.	Type	Details (Symptom, Possible Cause, Troubleshooting)
542	A	Heating roller warm-up error 1
		<ul style="list-style-type: none"> The heating roller temperature does not reach 80°C for 30 seconds. The center temperature of the heating roller does not reach the ready temperature for 90 seconds.
		<ul style="list-style-type: none"> Dirty or defective thermopile
		<ul style="list-style-type: none"> Check if the heating roller thermopile is firmly connected. Replace the thermopile.

No.	Type	Details (Symptom, Possible Cause, Troubleshooting)
543	A	Heating roller fusing lamp overheat 1 (software error)
		The temperature detected by the heating roller thermopile stays at 230°C for 1 second.
		<ul style="list-style-type: none"> Defective PSU Defective IPU Defective BCU
		Related SC code: SC 553
		<ul style="list-style-type: none"> Replace the PSU. Replace the IPU. Replace the BCU.

No.	Type	Details (Symptom, Possible Cause, Troubleshooting)
544	A	Heating roller fusing lamp overheat 1 (hardware error)
		During stand-by mode or a print job, the temperature detected by the heating roller thermopile reaches 250 °C.
		<ul style="list-style-type: none"> • Defective PSU • Defective IPU • Defective BCU • Defective fusing control system
		Related SC code: SC 543
		<ul style="list-style-type: none"> • Replace the PSU. • Replace the IPU. • Replace the BCU.

No.	Type	Details (Symptom, Possible Cause, Troubleshooting)
545	A	Heating roller fusing lamp consecutive full power 1
		When the fusing unit is not running in the ready condition, the heating roller fusing lamp keeps on full power for 8 seconds.
		<ul style="list-style-type: none"> • Broken heating roller fusing lamp
		Related SC code: SC 555
		<ul style="list-style-type: none"> • Replace the heating roller fusing lamp. • Replace the PSU.

No.	Type	Details (Symptom, Possible Cause, Troubleshooting)
547 -01	D	Zero cross error (Fusing relay short)
		<ul style="list-style-type: none"> The zero cross signal is detected three times even though the heater relay is off when turning on the main power. The zero cross signal is not detected for 3 seconds even though the heater relay is on after turning on the main power or closing the front door. The detection error occurs twice or more in the 11 zero cross signal detections. This error is defined when the detected zero cross signal is less than 45.
		<ul style="list-style-type: none"> Defective fusing lamp relay Defective fusing lamp relay circuit
		<ul style="list-style-type: none"> Replace the PSU. Replace the BCU.

No.	Type	Details (Symptom, Possible Cause, Troubleshooting)
547 -02	D	Zero cross error (Fusing relay open)
		<ul style="list-style-type: none"> The zero cross signal is detected three times even though the heater relay is off when turning on the main power. The zero cross signal is not detected for 2 seconds even though the heater relay is on after turning on the main power or closing the front door. The detection error occurs twice or more in the 11 zero cross signal detections. This error is defined when the detected zero cross signal is less than 45.
		<ul style="list-style-type: none"> Defective fusing lamp relay Defective fusing lamp relay circuit Short 24VS fuse
		<ul style="list-style-type: none"> Replace the 24VS fuse (FU3/FU4). Replace the PSU. Replace the BCU.

No.	Type	Details (Symptom, Possible Cause, Troubleshooting)
547-03	D	Zero cross error
		<ul style="list-style-type: none"> The zero cross signal is detected three times even though the heater relay is off when turning on the main power. The zero cross signal is not detected for 2 seconds even though the heater relay is on after turning on the main power or closing the front door. The detection error occurs twice or more in the 11 zero cross signal detections. This error is defined when the detected zero cross signal is less than 45.
		<ul style="list-style-type: none"> Unstable power supply
		<ul style="list-style-type: none"> Check the power supply source.

No.	Type	Details (Symptom, Possible Cause, Troubleshooting)
551	A	Heating roller thermistor error
		The temperature at the end of the heating roller measured by the heating roller thermistor does not reach 0°C for 7 seconds.
		<ul style="list-style-type: none"> Loose connection of pressure roller thermistor Defective heating roller thermistor
		Related SC code: SC 541
		<ul style="list-style-type: none"> Check that the heating roller thermistor is firmly connected. Replace the heating roller thermistor.

No.	Type	Details (Symptom, Possible Cause, Troubleshooting)
552	A	Heating roller warm-up error 2
		<ul style="list-style-type: none"> The heating roller temperature does not reach 80°C for 20 seconds. The temperature at the end of the heating roller does not reach the ready temperature for 89 seconds .
		<ul style="list-style-type: none"> Defective heating roller thermistor
		Related SC code: SC 542
		<ul style="list-style-type: none"> Check if the heating roller thermistor is firmly connected.

No.	Type	Details (Symptom, Possible Cause, Troubleshooting)
553	A	Heating roller fusing lamp overheat 2 (software error)
		The temperature detected by the heating roller thermistor stays at 230°C or more for 1 second.
		<ul style="list-style-type: none"> • Defective PSU • Defective IPU • Defective BCU
		<ul style="list-style-type: none"> • Replace the PSU. • Replace the IPU. • Replace the BCU.

No.	Type	Details (Symptom, Possible Cause, Troubleshooting)
554	A	Heating roller fusing lamp overheat 2 (hardware error)
		The temperature detected by the heating roller thermistor reaches 250°C or more.
		<ul style="list-style-type: none"> • Defective PSU • Defective IPU • Defective BCU • Defective fusing control system
		<ul style="list-style-type: none"> • Replace the PSU. • Replace the IPU. • Replace the BCU.

No.	Type	Details (Symptom, Possible Cause, Troubleshooting)
555	A	Heating roller lamp consecutive full power 2
		The heating roller-fusing lamp stays ON for 15 seconds or more while the fusing unit is in the ready condition.
		<ul style="list-style-type: none"> • Broken heating roller fusing lamp
		<ul style="list-style-type: none"> • Replace the heating roller fusing lamp. • Replace the PSU.

No.	Type	Details (Symptom, Possible Cause, Troubleshooting)
557	C	Zero cross frequency error
		When the zero cross signal is 66 or more and it is detected 10 times or more in 11 detections, the machine determines that input 60 Hz and SC557 occurs.
		<ul style="list-style-type: none"> Noise (High frequency) Defective PSU
		<ul style="list-style-type: none"> Check the power supply source. Replace the PSU.

No.	Type	Details (Symptom, Possible Cause, Troubleshooting)
559	A	Consecutive fusing jam
		The paper jam counter for the fusing unit reaches 3 times. The paper jam counter is cleared if the paper is fed correctly.
		This SC is activated only when SP1 159-001 is set to "1" (default "0").
		<ul style="list-style-type: none"> Paper jam in the fusing unit. Remove the paper that is jammed in the fusing unit.] Then make sure that the fusing unit is clean and has no obstacles in the paper feed path.

No.	Type	Details (Symptom, Possible Cause, Troubleshooting)
561	A	Pressure roller thermistor error
		The temperature detected by the pressure roller thermistor does not reach 0 °C for 20 seconds.
		<ul style="list-style-type: none"> Loose connection of the pressure roller thermistor Defective thermopile Defective pressure roller thermistor
		<ul style="list-style-type: none"> Check if the pressure roller thermistor is firmly connected. Replace the thermopile. Replace the pressure roller thermistor.

No.	Type	Details (Symptom, Possible Cause, Troubleshooting)
563	A	Pressure roller overheat (software error)
		The temperature detected by the pressure roller thermistor stays at 230°C or more for 1 second.
		<ul style="list-style-type: none"> • Defective PSU • Defective IPU • Defective BCU
		<ul style="list-style-type: none"> • Replace the PSU. • Replace the IPU. • Replace the BCU.

No.	Type	Details (Symptom, Possible Cause, Troubleshooting)
564	A	Pressure roller overheat (hardware error)
		The temperature detected by the pressure roller thermistor detects 250°C or more.
		<ul style="list-style-type: none"> • Defective PSU • Defective IPU • Defective BCU • Defective fusing control system
		<ul style="list-style-type: none"> • Replace the thermistor. • Replace the PSU. • Replace the IPU. • Replace the BCU.

No.	Type	Details (Symptom, Possible Cause, Troubleshooting)
565	A	Pressure roller fusing lamp consecutive full power
		When the fusing unit is not running in the ready condition, the pressure roller fusing lamp keeps ON full power for 300 seconds or more.
		<ul style="list-style-type: none"> • Broken pressure roller fusing lamp • Defective pressure roller thermistor
		<ul style="list-style-type: none"> • Replace the pressure roller lamp. • Replace the pressure roller thermistor. • Replace the PSU.

Service Call 6xx

SC6xx: Device Communication

No.	Type	Details (Symptom, Possible Cause, Troubleshooting)
620	D	ARDF communication error
		After the ARDF is detected, the break signal occurs or communication timeout occurs.
		<ul style="list-style-type: none"> • Incorrect installation of ARDF • ARDF defective • IPU defective
		<ul style="list-style-type: none"> • Check the cable connection of the ARDF. • Replace the ARDF. • Replace the IPU.

No.	Type	Details (Symptom, Possible Cause, Troubleshooting)
621	D	Finisher communication error
622	D	Paper tray unit communication error

No.	Type	Details (Symptom, Possible Cause, Troubleshooting)
-	-	<p>While the BCU communicates with an optional unit, an SC code is displayed if one of following conditions occurs.</p> <ul style="list-style-type: none"> • The IPU receives the break signal which is generated by the peripherals only just after the main switch is turned on. • When the BCU does not receive an OK signal from a peripheral 100ms after sending a command to it. The IPU resends the command. The IPU does not receive an OK signal after sending the command 3 times.
		<ul style="list-style-type: none"> • Cable problems • IPU problems • BCU problems • PSU problems in the machine • Main board problems in the peripherals
		<ul style="list-style-type: none"> • Check if the cables of peripherals are correctly connected. • Replace the PSU if no power is supplied to peripherals. • Replace the IPU or main board of peripherals. • Replace the BCU.

No.	Type	Details (Symptom, Possible Cause, Troubleshooting)
623	D	2nd Paper Bank communication error
		This SC is not issued for this machine.
		When a communication error signal between the 1st paper bank and 2nd paper bank is received.
		<ul style="list-style-type: none"> • Loose or disconnected connector
		Check the connection between the main machine and paper feed unit.

No.	Type	Details (Symptom, Possible Cause, Troubleshooting)	
632-00	B	Counter device error 1	CTL
		After 3 attempts to send a data frame to the optional counter device via the serial communication line, no ACK signal was received within 100 ms.	
		Serial line between the optional counter device, the relay board and copier control board is disconnected or damaged	
		<ul style="list-style-type: none"> • Make sure that SP5113 is set to enable the optional counter device. • Check the connection between the main machine and optional counter device. 	

No.	Type	Details (Symptom, Possible Cause, Troubleshooting)	
633-00	B	Counter device error 2	CTL
		After communication is established, the controller receives the brake signal from the accounting device.	
		Serial line between the optional counter device, the relay board and copier control board is disconnected or damaged	
		<ul style="list-style-type: none"> • Check if the setting of the SP5113 is correctly set. • Check the connection between the main machine and optional counter device. 	

No.	Type	Details (Symptom, Possible Cause, Troubleshooting)	
634-00	B	Counter device error 3	CTL
		A backup RAM error was returned by the counter device.	
		<ul style="list-style-type: none"> • Counter device control board defective • Backup battery of counter device defective 	
		Replace the counter device.	

No.	Type	Details (Symptom, Possible Cause, Troubleshooting)	
635-00	B	Counter device error 4	CTL
		A backup battery error was returned by the counter device.	
		<ul style="list-style-type: none"> Counter device control board defective Backup battery of counter device defective 	
		Replace the counter device.	

No.	Type	Details (Symptom, Possible Cause, Troubleshooting)	
636		SD Card Errors	CTL
636-01	D	Expanded authentication module error	CTL
		There is no expanded authentication module in the machine. The SD card or the file of the expanded authentication module is broken. There is no DESS module in the machine.	
		<ul style="list-style-type: none"> No expanded authentication module Defective SD card No DESS module 	
		<ul style="list-style-type: none"> Install the expanded authentication module. Install the SD card. Install the DESS module. 	
636-02	D	Version error	CTL
		The version of the expanded authentication module is not correct.	
		<ul style="list-style-type: none"> Incorrect module version 	
		Install the correct file of the expanded authentication module.	
636-11	D	OSM User Code File Error	CTL
		The correct "usercode" file could not be found in the root folder of the SD card because the file is not present, or the existing file is corrupted or the wrong type file.	
		Make sure the eccm.mod file is in the root folder of the SD card.	

No.	Type	Details (Symptom, Possible Cause, Troubleshooting)	
637-01	C	Tracking information communication error 1	CTL
		Communication to the tracking SDK application from the machine was lost.	
		<ul style="list-style-type: none"> Tracking information was lost, so an accurate count could not be achieved. 	
		Cycle the machine off/on.	
637-02	C	Tracking information communication error 2	CTL
		Communication with the tracking management server was lost, so an accurate count could not be achieved.	
		<ul style="list-style-type: none"> Network error Error on the tracking management server side Tracking SDK application error 	
		Cycle the machine off/on.	

No.	Type	Details (Symptom, Possible Cause, Troubleshooting)	
650-01	B	Remote Service Modem: Authentication error	CTL
		The authentication for the Embedded RCG-M fails at a dial up connection.	
		<ul style="list-style-type: none"> Incorrect SP settings Disconnected telephone line Disconnected modem board 	
		Check and set the correct user name (SP5816-156) and password (SP5816-157).	
650-04	B	Remote Service Modem: Incorrect modem setting	CTL
		Dial up fails due to the incorrect modem setting.	
		<ul style="list-style-type: none"> Incorrect SP settings Disconnected telephone line Disconnected modem board 	
		Check and set the correct AT command (SP5819-160).	

No.	Type	Details (Symptom, Possible Cause, Troubleshooting)	
650-05	B	Remote Service Modem: Communication error	CTL
		The supplied voltage is not sufficient due to the defective communication line or defective connection.	
		<ul style="list-style-type: none"> • Incorrect SP settings • Disconnected telephone line • Disconnected modem board 	
		Consult with the user's local telephone company.	
650-13	B	Remote Service Modem: Communication error	CTL
		A modem communication error occurred at dialing or when the machine was turned on. This error is displayed only if @ Remote is operating.	
		The @Remote SP settings are not correct, or the telephone line, modem board, or wireless LAN card is not connected.	
		<ul style="list-style-type: none"> • Incorrect SP settings • Disconnected telephone line • Disconnected modem board • Wireless LAN card not connected 	
650-14	B	Remote Service Modem: Communication error	CTL
		A modem communication error occurred at dialing or when the machine was turned on. This error is displayed only if @ Remote is operating.	
		The @Remote SP settings are not correct, or the telephone line, modem board, or wireless LAN card is not connected.	
		<ul style="list-style-type: none"> • Incorrect SP settings • Disconnected telephone line • Disconnected modem board • Wireless LAN card not connected 	

No.	Type	Details (Symptom, Possible Cause, Troubleshooting)	
651-01	C	@Remote incorrect dial up connection	CTL
		CHAT program parameter error.	
651-02	C	@Remote incorrect dial up connection	CTL
		CHAT program execution error	
		An unexpected error occurred when the modem (Embedded RCG-M) tried to call the center through the dial up connection.	
		<ul style="list-style-type: none"> Caused by a software bug No action required. These errors do not interfere with operation of the machine. 	

No.	Type	Details (Symptom, Possible Cause, Troubleshooting)	
652-00	D	@Remote service ID2 mismatch error 1	CTL
		The ID2 in the individual certificate does not match the ID2 in the NVRAM on the controller board.	
		<ul style="list-style-type: none"> The controller board in this machine has already been used in a machine in which RC Gate was installed. The controller board NVRAM in this machine has already been used in a machine in which RC Gate was installed. 	
		<p>If an error occurs at installation of the RC Gate:</p> <ul style="list-style-type: none"> Check that the individual certificate is correct for the NVRAM in the machine and that the ID2 is correct. Reinstall the RC Gate after writing the common certificate. <p>If an error occurs after installation of the RC Gate:</p> <ul style="list-style-type: none"> Clear the RC Gate data. Check that the individual certificate is correct for the NVRAM in the machine and that the ID2 is correct. Reinstall the RC Gate after writing the common certificate. 	

No.	Type	Details (Symptom, Possible Cause, Troubleshooting)	
653-00	D	@Remote service ID2 mismatch error 2	CTL
		The ID2 in the NVRAM on the controller board is incorrect.	
		<ul style="list-style-type: none"> • ID2 is not exactly 17 bytes. • ID2 includes text which cannot be printed. • ID2 is all filled by spaces. • ID2 is null. 	
		<ul style="list-style-type: none"> • Clear the RC Gate data. • Reinstall the RC Gate after writing the common certificate. • Replace NVRAM 	

No.	Type	Details (Symptom, Possible Cause, Troubleshooting)	
669	D	EEPROM error	
		Retry of EEPROM communication fails three times after the machine has detected the EEPROM error.	
		<ul style="list-style-type: none"> • Caused by noise 	
		Turn the main power switch off and on.	

No.	Type	Details (Symptom, Possible Cause, Troubleshooting)	
670-00	D	Engine start up error	CTL
		The ready signal from the engine board was not detected.	
		Case 1 <ul style="list-style-type: none"> No /ENGRDY signal asserted at power on, or when machine left low power mode. No response from EC from engine within the specified time at power on. No response from PC from engine within the specified time at power on. No response from SC from engine within the specified time at power on (MFP module only). Write to Rapi driver failed (no destination found at PCI). Case 2 <ul style="list-style-type: none"> Unexpected error occurred after /ENGRDY signal asserted. 	
		<ul style="list-style-type: none"> Check the connections between the controller and BCU Replace the BCU for 100% failure If occurrence of the error is sporadic, the firmware may need to be updated, or the controller board or PSU requires replacement 	

No.	Type	Details (Symptom, Possible Cause, Troubleshooting)	
SC681	D	RFID: Communication error	
		<ul style="list-style-type: none"> Communication error occurs at communication with the RFID receptor. Retry of RFID communication failed 	
		<ul style="list-style-type: none"> Defective RFID reader and writer Disconnected ASAP I/F No memory chip on the toner cartridge Noise 	

No.	Type	Details (Symptom, Possible Cause, Troubleshooting)
		<ul style="list-style-type: none"> • Remove and then re-insert each toner bottle. • Replace toner bottle. • Confirm that RFID connectors and harnesses are connected correctly. • If the connectors and harnesses are damaged, replace the RFID_CPU board and Harness: ANTENNA: Toner Supply. • Replace the affected RFID_AFE board (KMCY). (See table below.) • Replace BCU.

Use the table below to determine which color is affected.

Examples:

- SC681-06 > K
- SC681-27 > C
- SC681-24 > Y

6

RFID_AFE Board (KMCY)

K	C	M	Y
-06	-07	-08	-09
-11	-12	-13	-14
-16	-17	-18	-19
-21	-22	-23	-24
-26	-27	-28	-29
-31	-32	-33	-34
-36	-37	-38	-39
-41	-42	-43	-44
-46	-47	-48	-49
-51	-52	-53	-54
-56	-57	-58	-59

No.	Type	Details (Symptom, Possible Cause, Troubleshooting)
682	D	Memory chip at TD sensor: Communication error
		Retry of memory chip communication fails three times after the machine has detected the memory chip communication error.
		<ul style="list-style-type: none"> • Damaged memory chip data • Disconnected inter face • No memory chip on the development unit • Noise
		<ul style="list-style-type: none"> • Replace the PCDU. • Replace the BCU.

No.	Type	Details (Symptom, Possible Cause, Troubleshooting)
683	B	RFID: Unit check error
		The machine gets RFID communication error even the toner cartridges have not been installed in the machine.
		Caused by noise
		Turn the main power switch off and on.

No.	Type	Details (Symptom, Possible Cause, Troubleshooting)
687	D	Memory address command error
		The BCU does not receive a memory address command from the controller 120 seconds after paper is in the position for registration.
		<ul style="list-style-type: none"> • Loose connection • Defective controller • Defective BCU
		<ul style="list-style-type: none"> • Check if the controller is firmly connected to the BCU. • Replace the controller. • Replace the BCU.

No.	Type	Details (Symptom, Possible Cause, Troubleshooting)
690	D	GAVD communication error
		<ul style="list-style-type: none"> • The I2C bus device ID is not identified during initialization. • A device-status error occurs during I2C bus communication. • The I2C bus communication is not established due to an error other than a buffer shortage.
		<ul style="list-style-type: none"> • Loose connection • Defective BCU • Defective IPU
		<ul style="list-style-type: none"> • Turn the main switch off and on. • Check the cable connection. • Replace the IPU. • Replace the BCU board.

Service Call 7xx

SC7xx: Peripherals

No.	Type	Details (Symptom, Possible Cause, Troubleshooting)
724 -24	B	Finisher exit guide plate motor error (with the side tray installed)
		After moving away from the guide plate position sensor, the exit guide is not detected at the home position within the prescribed time. The 1st detection failure issues a jam error, and the 2nd failure issues this SC code.
		<ul style="list-style-type: none"> • Guide plate motor disconnected, defective • Guide plate motor overloaded due to obstruction • Guide plate position sensor disconnected, defective
		<ul style="list-style-type: none"> • Check the connections and cables for the components mentioned above. • Check for blockages in the guide plate motor mechanism. • Replace the guide plate position sensor and/or guide plate motor • Replace the finisher main board.

No.	Type	Details (Symptom, Possible Cause, Troubleshooting)
724 -30	B	Finisher jogger motor error
		The jogger fences move out of the home position but the HP sensor output does not change within the specified number of pulses.
		The 1st failure issues an original jam message, and the 2nd failure issues this SC code.
		<ul style="list-style-type: none"> • Jogger HP sensor disconnected, defective • Jogger motor disconnected, defective • Jogger motor overloaded due to obstruction • Finisher main board and jogger motor
		<ul style="list-style-type: none"> • Check the connections and cables for the components mentioned above. • Check for blockages in the jogger motor mechanism. • Replace the jogger HP sensor and/or jogger motor. • Replace the finisher main board.

No.	Type	Details (Symptom, Possible Cause, Troubleshooting)
724 -38	B	Finisher pick-up solenoid error (with the side tray installed)
		<ul style="list-style-type: none"> • Solenoid harness loose, broken • Solenoid obstructed • Solenoid defective
		<ul style="list-style-type: none"> • Check or replace the solenoid harness. • Replace the pick-up solenoid.

No.	Type	Details (Symptom, Possible Cause, Troubleshooting)
724 -44	B	Finisher corner stapler motor error
		The 1st detection failure issues a jam error, and the 2nd failure issues this SC code.
		For internal finisher <ul style="list-style-type: none"> • The stapler motor does not switch off within the prescribed time after operating. • The HP sensor of the staple unit does not detect the home position after the staple unit moves to its home position. • The HP sensor of the staple unit detects the home position after the staple unit moves from its home position.
		<ul style="list-style-type: none"> • Staple jam • Motor overload • Defective stapler motor
		<ul style="list-style-type: none"> • Check the connections and cables for the components mentioned above. • Replace the HP sensor and/or stapler motor • Replace the finisher main board.

No.	Type	Details (Symptom, Possible Cause, Troubleshooting)
724 -70	B	Finisher tray lift motor error (with the side tray installed)
		<ul style="list-style-type: none"> • Motor overload • Loose connection of the tray lift motor • Defective tray lift motor
		<ul style="list-style-type: none"> • Check the connections to the tray lift motor. • Replace the tray lift motor.

No.	Type	Details (Symptom, Possible Cause, Troubleshooting)
724 -71	B	Finisher tray shift motor error (with the side tray installed)
		The shift roller HP sensor of the upper tray does not activate within the prescribed time after the shift tray starts to move toward or away from the home position. The 1st detection failure issues a jam error, and the 2nd failure issues this SC code.
		<ul style="list-style-type: none"> • Shift tray HP sensor of the upper tray disconnected, defective • Shift tray motor of the upper tray is disconnected, defective • Shift tray motor of the upper tray overloaded due to obstruction
		<ul style="list-style-type: none"> • Check the connections and cables for the components mentioned above. • Check for blockages in shift motor mechanism. • Replace the shift tray HP sensor and/or shift motor • Replace the finisher main board.

No.	Type	Details (Symptom, Possible Cause, Troubleshooting)
724 -81	B	Finisher exit guide plate motor error
		<ul style="list-style-type: none"> • Motor overload • Loose connection of the exit guide plate motor • Defective exit guide plate motor
		<ul style="list-style-type: none"> • Check the connections to the exit guide plate motor. • Replace the exit guide plate motor.

No.	Type	Details (Symptom, Possible Cause, Troubleshooting)
793	B	Finisher gathering roller motor error
		<ul style="list-style-type: none"> • Motor overload • Loose connection of the gathering roller motor • Defective gathering roller motor
		<ul style="list-style-type: none"> • Check the connections to the gathering roller motor. • Replace the gathering roller motor.

No.	Type	Details (Symptom, Possible Cause, Troubleshooting)
795	B	Finisher shift roller motor error
		<ul style="list-style-type: none"> • Motor overload • Loose connection of the shift roller motor • Defective shift roller motor
		<ul style="list-style-type: none"> • Check the connections to the shift roller motor. • Replace the shift roller motor.

No.	Type	Details (Symptom, Possible Cause, Troubleshooting)
796	B	Finisher tray lift motor error
		<ul style="list-style-type: none"> • Motor overload • Loose connection of the tray lift motor • Defective tray lift motor
		<ul style="list-style-type: none"> • Check the connections to the tray lift motor. • Replace the tray lift motor.

SC797 added
RTB 40

Service Call 8xx

SC8xx: Overall System

No.	Type	Details (Symptom, Possible Cause, Troubleshooting)	
816-00	D	Energy save I/O subsystem error	CTL
816-01	D	Sub system error	
816-02	D	sysarch(LPUX_GET_PORT_INFO) error	
816-03	D	STR shift reject	
816-04	D	Write error generated by kernel communication driver	
816-05	D	STR pre-shift processing error	
816-07	D	sysarch(LPUX_GET_PORT_INFO) error	
816-08	D	sysarch(LPUX_ENGINE_TIMERCTRL) error	
816-09	D	sysarch(LPUX_RETURN_FACTOR_STR) error	
816-10 to 12	D	sysarch(LPUX_GET_PORT_INFO) error	
816-13	D	open Error	
816-14	D	Memory address setting error	
816-15 to 18	D	open Error	
816-19	D	Duplicate open error	
816-20	D	open Error	
816-22	D	Parameter error	
816-23 and 24	D	read Error	
816-25	D	write Error	

No.	Type	Details (Symptom, Possible Cause, Troubleshooting)
816 -26 to 30	D	write communication retry error
816-35	D	read Error
816 -36 to 94	D	Sub System Error
		<p>Low power I/O sub system detected an error. Normally, these are not fatal errors.</p> <ul style="list-style-type: none"> • Low power I/O sub system error • Low power I/O sub system command board error (no response) • Error detected before STR shift processing
		<ul style="list-style-type: none"> • Cycle the machine off/on. • If cycling the machine off/on does not solve the problem, replace the controller board.

No.	Type	Details (Symptom, Possible Cause, Troubleshooting)		
819-00	---	<table border="1"> <tr> <td>Kernel Errors</td> <td>CTL</td> </tr> </table>	Kernel Errors	CTL
Kernel Errors	CTL			
		Due to a controller error, a RAM overflow occurred during system processing, triggering one of the following messages on the operation panel.		
0x5355	D	L2 status timeout		
		<ul style="list-style-type: none"> • Cycle the machine off/on • Controller board defective • BCU defective • IPU defective 		
0x6261	D	HDD unit damaged		
		Machine cannot read hard disk.		
		<ul style="list-style-type: none"> • If installing a new disk, be sure to format the disk. • If the disk is already in use, format the HDD. • Replace HDD. 		

No.	Type	Details (Symptom, Possible Cause, Troubleshooting)	
0x696e	D	"gwint" process end	
		An error occurred at the end of SCS (System Control Service) processing. You may see the first 6 characters of the message "init died".	
		<ul style="list-style-type: none"> • Update the firmware • Replace controller board 	
0x766d	D	VM full	
		This error can occur if the RAM operates over maximum capacity. You may see the first 6 characters of the message: vm_pageout: VM is full.	
		<ul style="list-style-type: none"> • Update the firmware • Replace controller board 	
Other	D	"panic" string error	
		The memory, FLASH memory, or CPU could be corrupted or damaged. You may see the message: panic	
		<ul style="list-style-type: none"> • Replace controller board 	
Other	D	"init died" string error	
		A problem has occurred due to a software bug, incorrectly installed memory chip, or the RAM, FLASH memory, or CPU is damaged or corrupted.	
		<ul style="list-style-type: none"> • Update the firmware • Replace BCU • Replace controller board 	

No.	Type	Details (Symptom, Possible Cause, Troubleshooting)	
840-00	B	EEPROM error 1: EEPROM access	CTL
		<ul style="list-style-type: none"> • During the I/O processing, a read error occurred. The 3rd reading failure causes this SC code. • During the I/O processing, a write error occurred. 	
		<ul style="list-style-type: none"> • Defective EEPROM 	

No.	Type	Details (Symptom, Possible Cause, Troubleshooting)	
841-00	B	EEPROM error 2: EEPROM read/write error	CTL
		Mirrored data of the EEPROM is different from the original data in EEPROM.	
		<ul style="list-style-type: none"> Data in EEPROM was overwritten for some reason. 	

No.	Type	Details (Symptom, Possible Cause, Troubleshooting)	
842-00	C	NAND-Flash Update Verify Error Detected.	CTL
		SCS write error (verify error) occurred at the Nand-Flash module when remote ROM or main ROM was updated.	
		Nand-Flash failed	
		<ul style="list-style-type: none"> Cycle the machine off/on. Replace controller board 	
842-01	B	Insufficient Nand-Flash blocks (threshold exceeded)	CTL
		At startup, or when machine returned from low power mode, the Nand-Flash status was read and judged that the number of unusable blocks had exceeded threshold, and then SCS generated the SC code.	
		Number of unusable blocks exceeded threshold for Nand-Flash	
		<ul style="list-style-type: none"> Replace controller board 	
842-02	B	Number of Nand-Flash block deletions exceeded	CTL
		At startup, or when the machined returned from low power mode, the Nand-Flash was read and judged that the number of deleted blocks had exceeded threshold, and then SCS generated this SC code.	
		Number of blocks deleted exceeded threshold for Nand-Flash	
		<ul style="list-style-type: none"> Replace controller board 	

No.	Type	Details (Symptom, Possible Cause, Troubleshooting)	
853-00	B	Bluetooth device connection error	CTL
		The Bluetooth device (USB type) was connected after the machine was powered on.	
		Always connect the Bluetooth device (USB type) before the machine is powered on.	
		<ul style="list-style-type: none"> • Turn the machine off. • Insert the Bluetooth device into either USB Host interface socket on the controller board faceplate. • Turn the machine on. 	

No.	Type	Details (Symptom, Possible Cause, Troubleshooting)	
854-00	B	Bluetooth device removed	CTL
		This error occurred when the Bluetooth device (USB type) was removed.	
		<ul style="list-style-type: none"> • Loose connection • Defective wireless Bluetooth device 	
		<ul style="list-style-type: none"> • Make sure that the Bluetooth device has not been removed • Make sure that it is inserted securely in the USB Host Interface socket on the controller board faceplate. 	

No.	Type	Details (Symptom, Possible Cause, Troubleshooting)	
855-01	B	Wireless LAN card error 1	CTL
		A problem occurred when the installed Wireless LAN device was installed because is not supported by this machine, or the Wireless LAN device is defective.	
		Wireless LAN device is not connected correctly, or the device is defective.	
		<ul style="list-style-type: none"> • Make sure that the wireless LAN is supported by this machine (IEEE 802.11 Interface Unit Type O M417). • Make sure that the device is installed correctly. 	

No.	Type	Details (Symptom, Possible Cause, Troubleshooting)	
855-02		Wireless LAN card error 2	CTL
		A problem occurred when the Wireless LAN device was not initialized at power on.	
		The device is not installed correctly.	
		<ul style="list-style-type: none"> • Switch the machine off. • Make sure that the device is installed correctly. 	

No.	Type	Details (Symptom, Possible Cause, Troubleshooting)	
857-00	B	USB interface error	CTL
		The USB interface cannot be used due to a driver error.	
		<ul style="list-style-type: none"> • Defective USB driver • Loose connection 	
		<ul style="list-style-type: none"> • Check the connection. • Replace the controller board. 	

No.	Type	Details (Symptom, Possible Cause, Troubleshooting)	
858-00	A	Data encryption error	CTL
		When the data encryption key was updated, data was converted but a serious error occurred.	
		<ul style="list-style-type: none"> • Defective controller board 	
858-01	A	HDD Key Setting Error	CTL
		USB Flash, other data, corrupted. Communication error caused by electrostatic noise	
		<ul style="list-style-type: none"> • Controller board defective 	
858-02	A	NVRAM Read Error	CTL
		<ul style="list-style-type: none"> • NVRAM defective • Replace NVRAMs on controller board 	
858-30	A	NVRAM Before Replace Error	CTL

No.	Type	Details (Symptom, Possible Cause, Troubleshooting)	
		Software parameters caused error caused by at data conversion	
		Replace controller board.	
858-31		Other Error	CTL
		Replace controller board.	

No.	Type	Details (Symptom, Possible Cause, Troubleshooting)	
859-00	B	HDD unit error at power on	CTL
		When the data encryption key was updated, HDD data was converted, but not correctly. Image displayed at conversion only (this SC is not displayed), but SC is displayed after machine is cycled off/on.	
		<ul style="list-style-type: none"> • Check HDD installation • Format the HDD • Replace HDD 	
859-01	B	HDD check error	CTL
		<ul style="list-style-type: none"> • HDD conversion was set with the data encryption key update function, but the HDD was removed. • Machine lost power during data encryption key update • Electrostatic noise, or an HDD error occurred, during data encryption key update, and data was not encrypted. 	
		<ul style="list-style-type: none"> • Check HDD installation • Format the HDD • Replace HDD 	
859-02	B	Power loss during data encryption	CTL
		Power loss occurred while the data encryption key was being updated.	
		Make sure the machine is connected to the power source, and then turn it on.	
859-10	B	Data read command error	CTL

No.	Type	Details (Symptom, Possible Cause, Troubleshooting)
		<ul style="list-style-type: none"> Machine lost power during data encryption key update Electrostatic noise, or an HDD error occurred, during data encryption key update, and data was not encrypted.
		<ul style="list-style-type: none"> Check HDD installation Format the HDD Replace HDD

No.	Type	Details (Symptom, Possible Cause, Troubleshooting)
860-00	B	HDD startup error at power on CTL
		HDD is connected but a driver error is detected, or the driver did not respond with the status of the HDD within 30 s.
		<ul style="list-style-type: none"> HDD is not initialized Level data is corrupted HDD is defective
		<ul style="list-style-type: none"> Reformat the HDD. Replace the HDD.

No.	Type	Details (Symptom, Possible Cause, Troubleshooting)
863	---	<p>These errors can occur if the hard disk is defective, or has not been formatted correctly.</p> <ul style="list-style-type: none"> An HDD is divided into partitions. The first partition is the "Disk Label Partition", and then the other partitions are labeled A to V. The messages tell exactly where on the HDD where data has been corrupted and cannot be read. Although there are many messages listed below, the two step procedure is the same in all cases.
863-01	D	Disk Label Partition CTL
863-02 to 23	D	Partition A to V CTL

No.	Type	Details (Symptom, Possible Cause, Troubleshooting)
		<p>After one of these errors appears:</p> <ul style="list-style-type: none"> • First, format the hard disk. • Next, if formatting the disk did not solve the problem, replace the HDD unit.

No.	Type	Details (Symptom, Possible Cause, Troubleshooting)
864	---	HDD data CRC error
		<p>Data transfer did not execute normally while data was being written to the HDD because the HDD could not respond to a CRC error query. These errors can occur if the hard disk is defective, or has not been formatted correctly.</p> <ul style="list-style-type: none"> • An HDD is divided into partitions. The first partition is the "Disk Label Partition", and then the other partitions are labeled A to V. • The messages tell exactly where on the HDD where data has been corrupted and cannot be read. • Although there are many messages listed below, the two step procedure is the same in all cases.
864-01	D	Disk Label Partition
864-02 to 23	D	Partition A to V
		<p>After one of these errors appears:</p> <ul style="list-style-type: none"> • First, format the hard disk. • Next, if formatting the disk did not solve the problem, replace the HDD unit.

No.	Type	Details (Symptom, Possible Cause, Troubleshooting)
865	---	HDD access error

No.	Type	Details (Symptom, Possible Cause, Troubleshooting)	
		<p>A spurious error occurred (other than SC863, SC864) during operation of the HDD.</p> <p>These errors can occur if the hard disk is defective, or has not been formatted correctly.</p> <p>An HDD is divided into partitions. The first partition is the "Disk Label Partition", and then the other partitions are labeled A to V.</p> <p>The messages tell exactly where on the HDD where data has been corrupted and cannot be read.</p> <p>Although there are many messages listed below, the two step procedure is the same in all cases.</p>	
865-01	D	Disk Label Partition	CTL
865-02 to 23	D	Partition A to V	CTL
		<p>After one of these errors appears:</p> <ul style="list-style-type: none"> • The HDD unit is defective • Replace the HDD unit. 	

No.	Type	Details (Symptom, Possible Cause, Troubleshooting)	
866-00	B	SD card authentication error	CTL
		The machine detected an electronic license error in the application on the SD card in the SD card slot immediately after the machine was turned on.	
		<ul style="list-style-type: none"> • There is an illegal program on the SD card • SD card is defective 	
		<ul style="list-style-type: none"> • Store correct data on the SD card. 	

No.	Type	Details (Symptom, Possible Cause, Troubleshooting)	
867-001	B	SD card not found in Slot 1	CTL
		.The controller cannot start the application because it cannot detect the SD card in Slot 1.	
		<ul style="list-style-type: none"> • The SD card has been removed, or is not inserted completely • The SD card is defective • The SD card is not for use with this machine. 	
		<ul style="list-style-type: none"> • Make sure the SD card is inserted completely. • Check the SD card and make sure that it is for use with this machine. • Make sure that the SD card should be inserted into Slot 1. • Insert the SD card into the machine. • Cycle the machine off/on. • If these simple procedures cannot solve the problem, replace the NVRAMs on the controller board. 	
867-002	B	SD card not found in Slot 2	CTL
		.The controller cannot start the application because it cannot detect the SD card in Slot 2	
		<ul style="list-style-type: none"> • The SD card has been removed, or is not inserted completely • The SD card is defective • The SD card is not for use with this machine. 	
		<ul style="list-style-type: none"> • Make sure the SD card is inserted completely. • Check the SD card and make sure that it is for use with this machine. • Make sure that the SD card should be inserted into Slot 2. • Insert the SD card into the machine. • Cycle the machine off/on. • If these simple procedures cannot solve the problem, replace the NVRAMs on the controller board. 	

No.	Type	Details (Symptom, Possible Cause, Troubleshooting)	
868-01	D	SD card access error at Slot 1	CTL
868-01	D	SD card access error at Slot 2	CTL
		<p>A data access error occurred on the SD card in Slot 1 while an application was running.</p> <p>The SD card has been corrupted.</p> <ul style="list-style-type: none"> • For a system error, format the SD card on a PC. • For a device error, cycle the machine off/on. • SD card defective • NVRAM defective • Controller defective 	
		<p>A data access error occurred on the SD card in Slot 2 while an application was running.</p> <p>The SD card has been corrupted.</p> <ul style="list-style-type: none"> • For a system error, format the SD card on a PC. • For a device error, cycle the machine off/on. • SD card defective • NVRAM defective • Controller defective 	

No.	Type	Details (Symptom, Possible Cause, Troubleshooting)	
870	---	Address book data errors	CTL

No.	Type	Details (Symptom, Possible Cause, Troubleshooting)
		The following errors occur when the address book data cannot be read from the HDD or SD card where it was stored, or the data read from the media is defective.
		<ul style="list-style-type: none"> • Software defective. • Address book lookup mismatch error (server setting, LDAP setting) • Address book encryption setting or encryption key mismatch error (after NVRAM or HDD replaced separately and address book was not initialized) • The media holding the address book data (SD card, HDD) was removed temporarily, or application not compatible with machine • Address book data corrupted at access
		<ul style="list-style-type: none"> • Initialize the address book data with SP5-846-050. • Initialize the user information with SP5-832-006. • Replace the HDD.
870-00	B	Address book error
		Temporary address book error (another error that does not apply to other errors listed below)
870-01	B	Required media missing
		No media to hold the saved address book data at startup.
870-02	B	No DESS module for encryption
		The setting that enables data encryption at startup did not find the required module (DESS).
870-03	B	Address book initialization error 1
		At initialization failed to generate file required to save the address book data.
870-04	B	Address book initialization error 2
		At initialization failed to generate file required to save destination data.
870-05	B	Address book initialization error 3
		At initialization the file required to generate destination address data failed.

No.	Type	Details (Symptom, Possible Cause, Troubleshooting)
870-06	B	Address book initialization error 4
		At initialization failed to generate file required for LDAP search.
870-07	B	Address book initialization error 5
		At initialization failed to initialize entry information required by the system.
870-08	B	Address book initialization error 6
		At initialization there was a setting on the HDD required by the system for entry, but the initialization of the area to hold the address book failed to initialize.
870-09	B	NVRAM area mismatch error
		Mismatch error occurred in NVRAM device setting for the area where the information required to save the address book configuration is stored.
870-10	B	Directory creation error
		No directory created for storage of the address book data in SD/USB Flash ROM (device setting).
870-11	B	Mismatch error at startup
		Mismatch error occurred with address book items at startup
870-20	B	Initialization failure
		File I/O: file initialization failed
870-21	B	File creation failure
		File I/O: file creation failed
870-22	B	File open failure
		File I/O: file open failed
870-23	B	File write failure
		File I/O: file write failed
870-24	B	File read failure
		File I/O: file read failed

No.	Type	Details (Symptom, Possible Cause, Troubleshooting)
870-25	B	File size check failure
		File I/O: file size check failed
870-26	B	File erase failure
		File I/O: data erasure failed
870-27	B	File data add failure
		File I/O: data add failed
870-30	B	Data retrieve failure
		Failed to retrieve data from cache when the address book was searched for a destination or remote receiver
870-31	B	Data retrieve from cache failure
		Failed to retrieve data from cache when LDAP was searched
870-32	B	Data retrieve from WS Scanner address book failure
		Failed to retrieve WS-Scanner address book data from the cache
870-41	B	Cache data retrieve failure
		Failed to retrieve data from cache
870-50	B	Encryption error at startup
		Address book data encryption error at startup
870-51	B	Directory creation error for encryption
		Failed to create directory required to convert normal data to encrypted data
870-52	B	Encryption error: Normal to encrypted data
		Failed to convert normal data to encrypted data
870-53	B	Encryption error: Encrypted to normal data
		Failed to convert encrypted data to normal data
870-54	B	Mismatch error during retrieval from encrypted address book

No.	Type	Details (Symptom, Possible Cause, Troubleshooting)
		Data mismatch occurred when data was retrieved from encrypted address book
870-55	B	File delete error after settings changed
		Failed to delete files when setting was changed
870-56	B	File creation error for encryption key
		Failed to create special file to hold encryption key when files were deleted
870-57	B	File move error after encryption settings changed
		Failed to move files when data encryption setting was changed
870-58	B	Directory delete error after encryption settings changed
		Failed to delete directory for data encryption setting change
870-59	B	Insufficient resources after settings changed
		Insufficient resources detected when data encryption setting was changed
870-60	B	Failure to retrieve permission setting
		Could not retrieve system administrator permission setting

No.	Type	Details (Symptom, Possible Cause, Troubleshooting)
872-00	B	HDD mail data error
		An error was detected on the HDD at power on.
		<ul style="list-style-type: none"> Defective HDD Power failure while reading data from HDD
		<ul style="list-style-type: none"> Cycle the machine off/on. Initialize the HDD partitions with SP5-832-007. Replace the HDD.

No.	Type	Details (Symptom, Possible Cause, Troubleshooting)	
873-00	B	HDD mail send error	CTL
		HDD error detected at power on.	
		<ul style="list-style-type: none"> Defective HDD Power failure during an access to the HDD 	
		<ul style="list-style-type: none"> Initialize the HDD partition with SP5-832-008. Replace the HDD. 	

No.	Type	Details (Symptom, Possible Cause, Troubleshooting)	
875-01	D	HDD check failure (hddchack -i)	CTL
		During deletion of data from the HDD, and error was detected before HDD erase.	
		<ul style="list-style-type: none"> HDD logic delete failed Failed to delete every module holding data 	
		<ul style="list-style-type: none"> Cycle the machine off/on and try again. 	
875-02		Data delete failure	CTL
		Failure to delete all data on the HDD.	
		<ul style="list-style-type: none"> HDD logic delete failed Failed to delete every module holding data 	
		<ul style="list-style-type: none"> Cycle the machine off/on and try again. 	

No.	Type	Details (Symptom, Possible Cause, Troubleshooting)	
876-00	D	Log Data Error	CTL
		An error was detected in the handling of the log data at power on or during machine operation. This can be caused by accidentally switching the machine off while it is operating.	
876-01	D	Log Data Error 1	
		<ul style="list-style-type: none"> Damaged log data file in the HDD 	
		<ul style="list-style-type: none"> Initialize the HDD with SP5832-004. 	

No.	Type	Details (Symptom, Possible Cause, Troubleshooting)	
876-02	D	Log Data Error 2	
		<ul style="list-style-type: none"> • An encryption module not installed 	
		<ul style="list-style-type: none"> • Disable the log encryption setting with SP9730-004 ("0" is off.) • Install the DESS module. 	
876-03	D	Log Data Error 3	
		<ul style="list-style-type: none"> • Invalid log encryption key due to defective NVRAM data 	
		<ul style="list-style-type: none"> • Initialize the HDD with SP5832-004. • Disable the log encryption setting with SP9730-004 ("0" is off.) 	
876-04	D	Log Data Error 4	
		<ul style="list-style-type: none"> • Unusual log encryption function due to defective NVRAM data 	
		<ul style="list-style-type: none"> • Initialize the HDD with SP5832-004. 	
876-05	D	Log Data Error 5	
		<ul style="list-style-type: none"> • Installed NVRAM or HDD which is used in another machine 	
		<ul style="list-style-type: none"> • Reinstall the previous NVRAM or HDD. • Initialize the HDD with SP5832-004. 	
876-99	D	Log Data Error 99	
		<ul style="list-style-type: none"> • Other than the above causes 	
		<ul style="list-style-type: none"> • Contact your supervisor. 	

No.	Type	Details (Symptom, Possible Cause, Troubleshooting)	
877-00	B	HDD delete error	CTL
		The file delete phase of the Data Overwrite Security application did not execute.	
		<ul style="list-style-type: none"> • SD card (Data Overwrite Security) was removed • SD card defective 	
		<ul style="list-style-type: none"> • Replace the NVRAM and then install the new SD card. • Check and reinstall the SD card. 	

No.	Type	Details (Symptom, Possible Cause, Troubleshooting)	
878-00	D	TPM system authentication error	CTL
		TPM electronic recognition failure	
		<p>Note: In computing, Trusted Platform Module (TPM) is the name of a published specification detailing a secure crypto processor that can store cryptographic keys that protect information, as well as the general name of implementations of that specification, often called the "TPM chip" or "TPM Security Device" (as designated in certain Dell BIOS settings).</p>	
		<ul style="list-style-type: none"> • Update of system module attempted without correct update path • USB flash memory not operating correctly • Controller board defective 	
		<ul style="list-style-type: none"> • Replace controller board 	
878-01	D	USB flash error	CTL
		There is a problem in the file system of the USB flash memory.	
		USB Flash system files corrupted	
		<ul style="list-style-type: none"> • Replace controller board 	
878-02	D	TPM error	CTL
		An error occurred in either TPM or the TPM driver	
		<ul style="list-style-type: none"> • TPM not operating correctly 	
878-03	D	TCSD error	CTL
		An error occurred in the TPM software stack.	
		TCSD (Trusted Computing Source Device) is the main portal to TPM.	
		<ul style="list-style-type: none"> • TPM, TPM software cannot start • A file required by TPM is missing 	
		<ul style="list-style-type: none"> • Replace controller board 	

No.	Type	Details (Symptom, Possible Cause, Troubleshooting)	
880-00	D	File Format Converter (MLB) error	CTL
		A request to get access to the MLB is not answered within the specified time.	
		<ul style="list-style-type: none"> Defective file format converter board 	
		<ul style="list-style-type: none"> Replace the file format converter board 	

No.	Type	Details (Symptom, Possible Cause, Troubleshooting)	
881-00	D	Management area error	CTL
		<ul style="list-style-type: none"> A problem was detected in the software This error may even occur is an IC card option is not installed. 	
		<ul style="list-style-type: none"> At login When a print job was received When WEB browser was opened 	
		<ul style="list-style-type: none"> Cycle the machine off/on 	

No.	Type	Details (Symptom, Possible Cause, Troubleshooting)	
899-00	C	Software error	CTL
		An unknown error occurred in the controller firmware	
		<ul style="list-style-type: none"> Cycle the machine off/on Update controller firmware Controller board defective 	

Service Call 9xx

SC9xx: Miscellaneous

No.	Type	Details (Symptom, Possible Cause, Troubleshooting)	
900-00	D	Electrical total counter error	CTL
		The total counter contains data that is not a number.	
		<ul style="list-style-type: none"> • NVRAM incorrect type • NVRAM defective or corrupted • Unexpected error from external source • When PRT received signals at SRM, the requested count did not complete. 	
		<ul style="list-style-type: none"> • Check the connection between the NVRAM and controller. • Replace the NVRAM. • Replace the controller. 	

6

No.	Type	Details (Symptom, Possible Cause, Troubleshooting)	
910	D	External Controller Error 1	CTL
911		External Controller Error 2	CTL
912		External Controller Error 3	CTL
913		External Controller Error 4	CTL
914		External Controller Error 5	CTL
-	-	The external controller alerted the machine about an error.	
-	-	<ul style="list-style-type: none"> • Please refer to the instructions for the external controller (application). 	

No.	Type	Details (Symptom, Possible Cause, Troubleshooting)	
920-02	B	Printer Error 2: WORK memory not acquired	CTL
920-03	B	Printer Error 3: Filter processing did not start	CTL
920-04	B	Printer Error 4: Filter process ended abnormally	CTL

No.	Type	Details (Symptom, Possible Cause, Troubleshooting)	
		An internal application error was detected and operation cannot continue. Firmware defective, or insufficient memory.	
		<ul style="list-style-type: none"> • Cycle the machine off/on • Replace controller firmware 	

No.	Type	Details (Symptom, Possible Cause, Troubleshooting)	
921-00	D	Printer font error	CTL
		When the printer application started, the specified font could not be found on the SD card.	
		<ul style="list-style-type: none"> • The specified font is not on the SD card • SD card data corrupted 	

No.	Type	Details (Symptom, Possible Cause, Troubleshooting)	
925-00	B	Net File function error	CTL
925-01	B	Net File function error	CTL
		The NetFile file management on the HDD cannot be used, or a NetFile management file is corrupted and operation cannot continue. The HDDs are defective and they cannot be debugged or partitioned, so the Scan Router functions (delivery of received faxes, document capture, etc.), Web services, and other network functions cannot be used.	
		HDD status codes are displayed below the SC code:	
		<ul style="list-style-type: none"> • HDD defective • Power loss while data was writing to HDD • Software bug 	
		<ul style="list-style-type: none"> • See procedures below 	

Here is a list of HDD status codes:

Display	Meaning
(-1)	HDD not connected
(-2)	HDD not ready

(-3)	No label
(-4)	Partition type incorrect
(-5)	Error returned during label read or check
(-6)	Error returned during label read or check
(-7)	"filesystem" repair failed
(-8)	"filesystem" mount failed
(-9)	Drive does not answer command
(-10)	Internal kernel error
(-11)	Size of drive is too small
(-12)	Specified partition does not exist
(-13)	Device file does not exist

Recovery from SC 925

Procedure 1

If the machine shows SC codes for HDD errors (SC860 to SC865) with SC 925, do the recovery procedures for SC860 to SC865.

Procedure 2

1. If the machine does not show one of the five HDD errors (SC860 to SC865), turn the machine power off and on.
2. If this is not the solution for the problem, then initialize the NetFile partition on the HDD with SP5832-11 (HDD Formatting – Ridoc I/F).

NetFiles: These are jobs printed from the document server using a PC and DeskTopBinder. Before you initialize the NetFile partition on the HDD, tell the customer:

- Received faxes on the delivery server will be erased
 - All captured documents will be erased
 - Desk Top Binder/Print Job Manager/Desk Top Editor job history will be erased
 - Documents on the document server, and scanned documents, will not be erased.
 - The first time that the network gets access to the machine, the management information must be configured again (this will use a lot of time).
3. Before you initialize the Netfile partition with SP5832-11, do these steps:
 4. In the User Tools mode, do Document Management> Batch Delete Transfer Documents.
 5. Do SP5832-11, and turn the machine off and on.

Procedure 3

1. If "Procedure 2" is not the solution for the problem, do SP5832-1 (HDD Formatting – All)
2. Cycle the machine off/on.

Note

- SP5832-001 erases all document and address book data on the hard disks. Consult with the customer before you do this SP code.

Procedure 4

If "Procedure 3" does not solve the problem, replace the HDD.

No.	Type	Details (Symptom, Possible Cause, Troubleshooting)	
990-00	D	Software error 1	CTL
		An unexpected operation was encountered by the software.	
		<ul style="list-style-type: none"> • Software crash, reboot the machine • If the HDDs have just been replaced, be sure to download the stamp data (SP 5853). • With SP5990 004(SMC Report – Logging Data), print the most recent information for SC990. • The SC990 information displays the file name, line number, and value. Report this information to your technical supervisor. For example: Function.c LINE: 123 VAL: 0 	

No.	Type	Details (Symptom, Possible Cause, Troubleshooting)	
991-00	C	Software continuity error	CTL
		The software has attempted to perform an unexpected operation. However, unlike SC 990, the object of the error is continuity of the software.	
		The software performed an unexpected function and the program cannot continue. Recovery processing allows the program to continue.	
		<ul style="list-style-type: none"> • Abnormal variable • Internal parameter error • Insufficient work memory • Hardware error not detected by SC 	

In order to get more details about SC991:

1. Execute SP7403 or print an SMC Report (SP5990) to read the history of the 10 most recent logged errors.
2. If you press the zero key on the operation panel with the SP selection menu displayed, you will see detailed information about the recently logged SC991, including the software file name, line number, and so on. Of these two methods, 1) is the recommended method, because another SC could write over the information for the previous SC.

No.	Type	Details (Symptom, Possible Cause, Troubleshooting)	
992-00	D	Undefined error (no SC code)	CTL
		An error not controlled by the system occurred (the error does not come under any other SC code). Software defective	
		<ul style="list-style-type: none"> • Re-install firmware 	

No.	Type	Details (Symptom, Possible Cause, Troubleshooting)	
994-00	C	Operation panel management error	CTL
		An error occurred because the number of records exceeded the limit for images managed in the service layer of the firmware. This can occur if there if there are too many application screens open on the operation panel.	
		<ul style="list-style-type: none"> • No action required. • This SC does not interfere with operation of the machine. 	

No.	Type	Details (Symptom, Possible Cause, Troubleshooting)	
995	D	CPM setting error	
	-001	<ul style="list-style-type: none"> • Defective BCU • EEPROM Replacement error <ol style="list-style-type: none"> 1. Install the previous EEPROM. 2. Input the serial number with SP5811-004, and turn the main power switch off/on. 	

No.	Type	Details (Symptom, Possible Cause, Troubleshooting)	
995	D	CPM setting error	
	-002	<ul style="list-style-type: none"> Defective NVRAM Defective controller <ol style="list-style-type: none"> Update the controller firmware. Install a new NVRAM, and turn off and on the main power switch after SC995-002 has occurred. 	
	-003	<ul style="list-style-type: none"> Incorrect type controller installed Defective controller <ol style="list-style-type: none"> Replace the controller with the correct type. 	
	-004	<ul style="list-style-type: none"> Incorrect model controller installed. <ol style="list-style-type: none"> Replace the controller with the correct model. 	

No.	Type	Details (Symptom, Possible Cause, Troubleshooting)	
997-00	B	Application function selection error	CTL
		The application selected by the operation panel key does not start or ends abnormally.	
		<ul style="list-style-type: none"> Software (including the software configuration) defective An option required by the application (RAM, DIMM, board) is not installed Nesting of the fax group addresses is too complicated 	
		<ul style="list-style-type: none"> Check the devices necessary for the application program. If necessary devices have not been installed, install them. Check that application programs are correctly configured. For a fax operation problem, simplify the nesting of the fax group addresses. Take necessary countermeasures specific to the application program. If the logs can be displayed on the operation panel, see the logs. 	

No.	Type	Details (Symptom, Possible Cause, Troubleshooting)	
998-00	D	Application start error	CTL
		No applications start within 60 seconds after the power is turned on.	
		<ul style="list-style-type: none"> • Loose connection of RAM-DIMM, ROM-DIMM • Defective controller • Software problem 	
		<ul style="list-style-type: none"> • Check the setting of SP5875-001. If the setting is set to "1 (OFF)", change it to "0 (OFF)". • Check if the RAM-DIMM and ROM-DIMM are correctly connected. • Reinstall the controller system firmware. • Replace the controller. 	

Note 1

If a problem always occurs in a specific condition (for example, printer driver setting, image file), the problem may be caused by a software error. In this case, the following data and information needs to be sent back to your product specialist. Please understand that it may take some time to get a reply on how to solve the problem, because in some cases the design staff in Japan must analyze the data.

- Symptom / Possible Causes / Action taken
- Summary sheet (SP mode "Printer SP", SP1-004 [Print Summary])
- SMC - All (SP5-990-001)
- SMC - Logging (SP5-990-004)
- Printer driver settings used when the problem occurs
- All data displayed on the screen (SC code, error code, and program address where the problem is logged.)
- Image file which causes the problem, if possible

Process Control Error Conditions

Developer Initialization Result

SP-3-014-001 (Developer Initialization Result)

No.	Result	Description	Possible Causes/Action
1	Successfully completed	Developer initialization is successfully completed.	-
2	Forced termination	Developer initialization was forcibly terminated.	<ul style="list-style-type: none"> A cover was opened or the main switch was turned off during the initialization. <ol style="list-style-type: none"> Do the developer initialization again when done in SP mode. Reinstall the engine main firmware if the result is the same. Turn the main switch off and on when done at unit replacement.
6	Vt error	Vt is more than 0.7V when Vcnt is 4.3V.	<ol style="list-style-type: none"> Make sure that the heat seal on the development unit is not removed. Defective TD sensor
7	Vcnt error 1	Vcnt is less than 4.7V when Vcnt is Vt target $\pm 0.2V$.	<ol style="list-style-type: none"> Defective TD sensor Vt target settings are not correct. Toner density error
8	Vcnt error 2	Vt is more than 0.7V when Vcnt is 4.3V and Vcnt is less than 4.7V when Vcnt is Vt target $\pm 0.2V$.	<ol style="list-style-type: none"> Make sure that the heat seal on the development unit is not removed. Defective TD sensor
9	Vcnt error 3	Vcnt is less than 4.7V.	<ol style="list-style-type: none"> Make sure that the heat seal on the development unit is not removed. Defective TD sensor Vt target settings are not correct. Toner density error

↓ Note

- The machine starts developer initialization after you set "Enable" in SP3-902-005, 006, 007, or 008. Developer initialization automatically resumes when you open and close the front door or turn the main switch off and on if an error other than Error 8 occurs.

Process Control Self-Check Result

Displayed number shows results of each color sensor check.

00000000 = YYCCMMKK

SP3-012-001 to -010 (Process Control Self-check Result)

No.	Result	Description	Possible Causes/Action
11	Successfully completed	Process control self-check successfully completed.	Check the Vsg adjustment. See the "Vsg Adjustment Result" following this table.
41	Vt error	Vt maximum or minimum error is detected.	<ul style="list-style-type: none"> Defective development unit Vt maximum error and an image is faint: <ol style="list-style-type: none"> 1. Replace the toner supply pump unit. Vt maximum error and an image is O.K.: <ol style="list-style-type: none"> 1. Replace the development unit. 2. Replace the BCU board. Vt minimum error: <ol style="list-style-type: none"> 1. Replace the development unit. 2. Replace the BCU board.
53	ID sensor coefficient (K5) detection error	Not enough data can be sampled.	<ul style="list-style-type: none"> Solid image is not sufficient density: <ol style="list-style-type: none"> 1. Retry the process control. 2. Replace the ID sensors. 3. Replace the BCU board. Solid image is O.K. <ol style="list-style-type: none"> 1. Replace the ID sensors. 2. Replace the BCU board. ID sensor is dirty: <ol style="list-style-type: none"> 1. Clean the ID sensors. 2. Retry the process control.

No.	Result	Description	Possible Causes/Action
54	ID sensor coefficient (K5) maximum/minimum error	When the K5 is more than the value of SP3-362-003 or less than the value of SP3-362-004, the error 54 is displayed.	<ul style="list-style-type: none"> ID sensor pattern density is too high or low. ID sensor or shutter is defective. Same as 53
55	Gamma error: Maximum	Gamma is out of range. $5.0 < \text{Gamma}$	<ul style="list-style-type: none"> ID sensor pattern density is too high. Hardware defective. Same as 53
56	Gamma error: Minimum	Gamma is out of range. $\text{Gamma} < 0.15$	<ul style="list-style-type: none"> ID sensor pattern density is too low. Hardware defective. 1. Same as 53 2. Replace the toner supply pump unit.
57	Vk error: Maximum	Vk is out of range. $150 < \text{Vk}$	<ul style="list-style-type: none"> ID sensor pattern density is too low. Hardware defective. Same as 53
58	Vk error: Minimum	Vk is out of range. $\text{Vk} < -150$	<ul style="list-style-type: none"> ID sensor pattern density is too high. Background dirty Hardware defective Same as 53
59	Sampling data error during gamma correction	Not enough data can be sampled during the gamma correction.	<ul style="list-style-type: none"> ID sensor pattern density is too high or low. Hardware defective Same as 53
99	Unexpected error	Process control fails.	<ul style="list-style-type: none"> Power Failure Check the power source.

Vsg Adjustment Result

SP3-325-001 to -010 (Vsg Adjustment Result)

No.	Result	Description	Possible Causes/Action
1	O.K	Vsg adjustment is correctly done.	-
2	ID sensor adjustment error	Vsg cannot be adjusted within $4.0 \pm 0.5V$.	<ul style="list-style-type: none"> • Dirty ID sensor (toner, dust, or foreign material) • Dirty transfer belt • Scratched image transfer belt • Defective ID sensor • Poor connection • Defective BCU <ol style="list-style-type: none"> 1. Clean the ID sensor. 2. Check the belt cleaning. Clean or replace the transfer belt. 3. Replace the image transfer belt. 4. Replace the ID sensor. 5. Check the connection. 6. Replace the BCU board.
3	ID sensor output error	ID sensor output is more than "Voffset Threshold" (SP3-324-004)	<ul style="list-style-type: none"> • Defective ID sensor • Poor connection • Defective BCU <ol style="list-style-type: none"> 1. Replace the ID sensor. 2. Check the connection. 3. Replace the BCU board.
9	Vsg Adjustment error	Vsg adjustment has not been completed.	<ul style="list-style-type: none"> • Other cases Retry SP3-321-010.

Line Position Adjustment Result

SP2-194-010 to -012 (Line Position Adjustment Result: M, C, Y)

This SP shows the number as a line position adjustment result on the LCD. It shows which color has an error (M, Y or C).

No.	Result	Description	Note
0	Not done	Line position adjustment has not been done.	-
1	Completed successfully	Line position adjustment has correctly been done,	-
2	Cannot detect patterns	ID sensors have not detected the patterns for line position adjustment.	See Note
3	Fewer lines on the pattern than the target	The patterns, which ID sensors have detected, are not enough for line position adjustment.	See Note
4	More lines on the pattern than the target	Not used in this machine.	-
5	Out of the adjustment range	ID sensors have correctly detected the patterns for line position adjustment, but a shift of patterns is out of adjustable range.	See Note
6-9	Not used	-	-

Note

- For details, see the "Troubleshooting Guide - Line Position Adjustment" section.

Troubleshooting Guide

Line Position Adjustment

When there are color registration errors on the output, do the line position adjustment as follows.

Test

1. Do SP2-111-003 (Mode c: rough adjustment).
2. Use SP2-194-007 to check if the result of the line position adjustment is correct (0: Completed successfully, 1: Not completed). If the result is "1", refer to 'Countermeasure list for color registration errors'.
3. Do SP2-111-001 (Mode a: fine adjustment twice).
4. Use SP2-194-007 to check if the result of the line position adjustment is correct (0: Completed successfully, 1: Not completed). If the result is "1", refer to 'Countermeasure list for color registration errors'.
5. Put some A4/LT paper on the by-pass tray.

Note

- When you print a test pattern, use the by-pass tray to feed the paper.

6. Print out test pattern "7" with SP2-109-003.
7. Check the printed output with a loupe.
8. If there are no color registration errors on the output, the line position adjustment is correctly done. If not, refer to the countermeasure list for color registration errors.

Countermeasure list for color registration errors

After Executing SP2-111-003

- Result: "1" in SP2-194-007
- Result: "2" or "3" (Line pattern detection failure) in SP2-194-010, -011, -012

Test pattern check	Possible cause/Countermeasure
White image, Abnormal image, Low density	<ul style="list-style-type: none"> Defective image processing unit Low density of test pattern Defective BCU <ol style="list-style-type: none"> Replace the high voltage power supply unit. Do the forced process control (SP3-011-001) or supply some toner (SP3-015-xxx). Replace the BCU.
Normal image, but with color registration errors	<ul style="list-style-type: none"> Defective ID sensor shutter Defective ID sensor Defective BCU <ol style="list-style-type: none"> Replace the ID sensor shutter solenoid. Replace the ID sensor. Replace the BCU.

After Executing SP2-111-003

- Result: "1" in SP2-194-007
- One of results: "5" (Out of adjustable range) in SP2-194-010, -011, -012.

Test pattern check	Possible cause/Countermeasure
The main scan registrations of M, C, Y are shifted by more than ± 15 mm from the main scan registration of K.	<ul style="list-style-type: none"> Defective laser unit Defective BCU <ol style="list-style-type: none"> Replace the laser unit. Replace the BCU.
The sub scan registrations of M, C, Y are shifted by more than ± 20 mm from the sub scan registration of K.	<ul style="list-style-type: none"> Defective image transfer belt Defective drive units Defective BCU <ol style="list-style-type: none"> Replace the image transfer belt. Replace the drum motor. Replace the BCU.

Test pattern check	Possible cause/Countermeasure
The main scan registration is shifted by more than ± 0.66 mm, but only at the central area of the image on the output.	<ul style="list-style-type: none"> • Defective ID sensor at center • Deformed center area on the image transfer belt • Defective BCU <ol style="list-style-type: none"> 1. Replace the ID sensor. 2. Replace the image transfer belt. 3. Replace the BCU.
The skew for M, C, Y is more than ± 0.75 mm from the main scan registration of K	<ul style="list-style-type: none"> • Defective PCDU • Defective laser optics housing unit • Defective BCU <ol style="list-style-type: none"> 1. Reinstall or replace the PCDU. 2. Replace the laser optics housing unit. 3. Replace the BCU.
Others	<ul style="list-style-type: none"> • Skew correction upper limit error • Defective BCU • Defective laser optics housing unit <ol style="list-style-type: none"> 1. Replace the BCU. 2. Replace the laser optics housing unit.

After Executing SP2-111-003

- Result: "1" in SP2-194-007
- Result: "0" in SP2-194-010, -011, -012.

Test pattern check	Possible cause/Countermeasure
	Do SP2-111-001 or -002.

After Executing SP2-111-001

- Result: "1" in SP2-194-007
- Result: "2" or "3" (Line pattern detection failure) in SP2-194-010, -011, -012

Test pattern check	Possible cause/Countermeasure
White image, Abnormal image, Low density	<ul style="list-style-type: none"> • Defective laser optics housing unit shutter • Defective image processing unit • Low density of test pattern • Defective BCU <ol style="list-style-type: none"> 1. Replace the shutter motor. 2. Replace the high voltage power supply unit. 3. Do the forced process control (SP3-011-001) or supply some toner (SP3-015-xxx). 4. Replace the BCU.
Normal image, but with color registration errors	<ul style="list-style-type: none"> • Defective ID sensor shutter • Defective ID sensor • Defective BCU <ol style="list-style-type: none"> 1. Replace the ID sensor shutter solenoid. 2. Replace the ID sensor. 3. Replace the BCU.

After Executing SP2-111-001

- Result: "1" in SP2-194-007
- Result: "5" (Out of adjustable range) in SP2-194-010, -011, -012

Test pattern check	Possible cause/Countermeasure
Low image density on the output	<ul style="list-style-type: none"> • Low pattern density <p>Do the forced process control (SP3-011-001) or supply some toner (SP3-015-xxx).</p>
The main scan registrations of M, C, Y are shifted by more than ± 1.4 mm from the main scan registration of K.	<ul style="list-style-type: none"> • No defective component • Defective laser optics housing unit • Defective BCU <ol style="list-style-type: none"> 1. Do SP2-111-003 again. 2. Replace the laser optics housing unit. 3. Replace the BCU.

Test pattern check	Possible cause/Countermeasure
<p>The sub scan registrations of M, C, Y are shifted by more than $\pm 1.4\text{mm}$ from the sub scan registration of K.</p>	<ul style="list-style-type: none"> • No defective component • Defective image transfer belt • Defective drive units • Defective BCU <ol style="list-style-type: none"> 1. Do SP2-111-003 again. 2. Replace the image transfer belt. 3. Replace the drum motor. 4. Replace the BCU.
<p>The main scan registration is shifted by more than $\pm 0.66\text{ mm}$, but only at the central area of the image on the output.</p>	<ul style="list-style-type: none"> • Defective ID sensor at center • Deformed center area on the image transfer belt • Defective BCU <ol style="list-style-type: none"> 1. Replace the ID sensor. 2. Replace the image transfer belt. 3. Replace the BCU.
<p>The skew for M, C, Y is more than $\pm 0.75\text{ mm}$ from the main scan registration of K. – at the end of the scan line?</p>	<ul style="list-style-type: none"> • Defective PCDU • Defective laser optics housing unit • Defective BCU <ol style="list-style-type: none"> 1. Reinstall or replace the PCDU. 2. Replace the laser optics housing unit. 3. Replace the BCU.
<p>Others</p>	<ul style="list-style-type: none"> • Skew correction upper limit error • Defective BCU • Defective laser optics housing unit <ol style="list-style-type: none"> 1. Replace the BCU. 2. Replace the laser optics housing unit.

After Executing SP2-111-001

- Result: "0" in SP2-194-007
- Result: No color registration errors in SP2-194-010, -011, -012

Test pattern check	Possible cause/Countermeasure
The main scan registration of K is shifted.	<ul style="list-style-type: none"> Abnormal SP setting value of main scan: K Adjust the value with SP2-101-001.
The main scan length of K is shifted.	<ul style="list-style-type: none"> Abnormal SP setting value of main scan length detection: K Adjust the value with SP2-185-001.

After Executing SP2-111-001

- Result: "0" in SP2-194-007
- Result: Color registration errors in SP2-194-010, -011, -012

Test pattern check	Possible cause/Countermeasure
Low image density on the output	<ul style="list-style-type: none"> Low pattern density Do the forced process control (SP3-011-001) or supply some toner (SP3-015-xxx).
The main scan registration is shifted, but only at the central area of the image on the output.	<ul style="list-style-type: none"> Defective ID sensor at center Deformed center area on the image transfer belt Defective BCU <ol style="list-style-type: none"> Replace the ID sensor. Replace the image transfer belt. Replace the BCU.
The main scan registrations of M, C, Y are shifted.	<ul style="list-style-type: none"> Defective laser optics housing unit Defective ID sensor Defective BCU Incorrect SP value <ol style="list-style-type: none"> Replace the laser optics housing unit. Replace the ID sensor. Replace the BCU. Adjust the value with SP2-182-004 to -021.

Test pattern check	Possible cause/Countermeasure
<p>The sub scan registrations of M, C, Y are shifted.</p>	<ul style="list-style-type: none"> • Defective image transfer belt • Defective drive units • Defective ID sensor • Defective BCU • Incorrect SP value <ol style="list-style-type: none"> 1. Replace the image transfer belt. 2. Replace the ID sensor. 3. Replace the drum motor. 4. Replace the BCU. 5. Adjust the value with SP2-182-022 to -039.
<p>The skew of M, C, Y is different.</p>	<ul style="list-style-type: none"> • Defective PCDU • Defective laser optics housing unit • Defective IPU <ol style="list-style-type: none"> 1. Reinstall or replace the PCDU. 2. Replace the laser optics housing unit. 3. Replace the IPU.
<p>The sub scan lines are shifted. Shifted lines appear cyclically.</p>	<ul style="list-style-type: none"> • Defective PCDU • Defective drive unit • Drum phase adjustment error <ol style="list-style-type: none"> 1. Do SP1-902-001 (Drum phase adjustment); see Replacement and Adjustment – Drive Unit – Gear Unit for details. 2. Reinstall or replace the PCDU. 3. Check or replace the drive unit.

Problem at Regular Intervals

Image problems may appear at regular intervals that depend on the circumference of certain components.

The following diagram shows the possible symptoms (black or white dots at regular intervals).

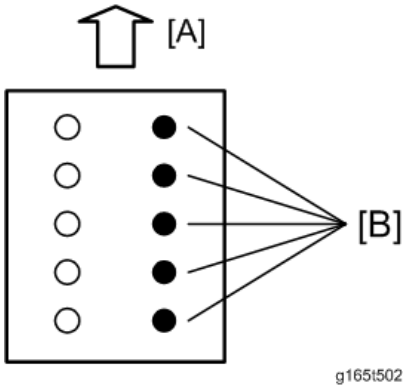

g1651502

[A]: Paper feed direction

[B]: Problems at regular intervals

- Abnormal image at 35-mm intervals: Charge roller
- Abnormal image at 795-mm intervals: Image transfer belt unit
- Colored spots at 41-mm intervals: Image transfer roller
- Colored spots at 82-mm intervals: Image transfer belt drive roller/ Image transfer belt idling roller
- Colored spots at 33-mm intervals: Development roller
- Abnormal image at 83-mm intervals: Paper transfer roller
- Colored spots at 94-mm intervals: OPC drum
- Spots at 141-mm intervals: Pressure roller
- Spots at 126-mm intervals: Fusing roller
- Spots at 204-mm intervals: Fusing belt

Blank Print

Symptom	Possible cause	Necessary actions
No image is printed.	Defective laser unit	Replace the laser unit.
	Defective PCDU	Replace the PCDU.
	Defective image transfer belt unit	Replace the image transfer belt unit.
	Incorrect action of paper transfer roller	Check the guide and the paper transfer roller.
	Defective HVPS	Replace HVPS.
	Defective BCU	Replace the BCU.

All-black Print

Symptom	Possible cause	Necessary actions
All the paper is black.	Incorrectly installed PCDU	Install the PCDU correctly.
	Defective PCDU	Replace the PCDU.
	Defective HVPS	Replace HVPS.
	Defective laser unit	Replace the laser unit.
	Defective BCU	Replace the BCU.
	Defective main board	Replace the main board.

Missing CMY Color

Symptom	Possible cause	Necessary actions
C, M, or Y is missing.	Defective PCDU	Replace the PCDU.
	Loose connection between printer cartridge and BCU	Replace the drum positioning cover.
	Image transfer belt not contacting PCDU	Check the belt tension unit.
	Defective the drum motor: CMY	Replace the drum motor: CMY.
	Defective BCU	Replace the BCU.

Light Print

Symptom	Possible cause	Necessary actions
Printed images are too weak.	Loose connection between paper transfer roller and HVPS	Check the connection between the paper transfer roller and the HVPS.
	Dust in the laser beam path	Clean the laser beam path.
	Image transfer belt not contacting PCDU	Check the image transfer belt unit.
	Defective PCDU	Replace the PCDU.
	Defective paper transfer roller	Repair the paper transfer roller.
	Defective fusing unit	Replace the fusing unit.
	Defective BCU	Replace the BCU.

Repeated Spots or Lines on Prints

The same spots or lines appear at regular intervals.

Interval	Possible cause	Necessary actions
At intervals of 35 mm (1.38 inches)	Defective charge roller	Replace the PCDU.
At intervals of 33 mm (1.3 inches)	Defective development roller	Replace the PCDU.
At intervals of 83 mm (3.27 inches)	Defective paper transfer roller	Replace the paper transfer roller unit.
At intervals of 94 mm (3.7 inches)	Defective OPC drum	Replace the PCDU.
At intervals of 126 mm (4.96 inches)	Defective fusing roller	Replace the fusing roller or fusing unit.
At intervals of 141 mm (5.55 inches)	Defective pressure roller	Replace the pressure roller or fusing unit.
At intervals of 204 mm (8.03 inches)	Defective fusing belt	Replace the fusing unit.
At intervals of 795 mm (31.3 inches)	Defective image transfer belt	Replace the image transfer belt or image transfer belt unit.
At intervals of 41 mm (1.61 inches)	Defective image transfer roller	Replace the image transfer roller.
At intervals of 82 mm (3.23 inches)	Defective image transfer belt drive roller or image transfer belt idling roller	Replace the image transfer belt drive roller or image transfer belt idling roller.

Dark Vertical Line on Prints

Symptom	Possible cause	Necessary actions
A dark line appears. The line is parallel to the paper feed direction of one CMY color.	Defective PCDU	Replace the PCDU.

Symptom	Possible cause	Necessary actions
A dark line appears. The line is parallel to the paper feed direction of any color (not C, M, or Y).	Dust in the laser beam path	Clean the laser beam path.
	Defective image transfer belt unit	Replace the image transfer belt unit.
	Defective fusing unit	Replace the fusing unit.

White Horizontal Lines or Bands

Symptom	Possible cause	Necessary actions
White lines or bands appear in images of all toner colors.	Defective PCDU	Replace the PCDU.
	Defective image transfer belt unit	Replace the image transfer belt unit.
	Defective paper transfer roller	Replace the paper transfer roller.

6

Missing Parts of Images

Symptom	Possible cause	Necessary actions
Some parts of images are missing.	Defective PCDU	Replace the PCDU.
	Defective image transfer belt unit	Replace the image transfer belt unit.
	Defective paper transfer roller	Replace the paper transfer roller.
	Defective fusing unit	Replace the fusing unit.

Dirty Background

Symptom	Possible cause	Necessary actions
Backgrounds of one CMYK color are too dense.	Defective PCDU	Replace the PCDU.

Symptom	Possible cause	Necessary actions
Backgrounds of more than one CMYK are too dense,color	Defective HVPS	Replace the HVPS.

Partial CMY Color Dots

Symptom	Possible cause	Necessary actions
Unexpected dots of the same color appear at irregular intervals.	Defective PCDU	Replace the PCDU.
	Defective image transfer belt unit	Replace the image transfer belt unit.
	Defective fusing unit	Replace the fusing unit.

Dark Irregular Streaks on Prints

Symptom	Possible cause	Necessary actions
Unexpected streaks appear at irregular intervals.	Defective image transfer belt	Replace the image transfer belt unit.

CMY Color Irregular Streaks

Symptom	Possible cause	Necessary actions
Unexpected streaks of the same color appear at irregular intervals.	Defective PCDU	Replace the PCDU.
	Defective image transfer belt unit	Replace the image transfer belt unit.

Ghosting

Symptom	Possible cause	Necessary actions
The same or similar image appears two or more times. They get weaker and weaker.	Defective PCDU	Replace the PCDU.
	Defective transfer unit	Replace the transfer unit.

Unfused or Partially Fused Prints

Symptom	Possible cause	Necessary actions
Some parts of images are not fused very well.	Non-standard paper in use	Use recommended paper.
	Incorrect media type mode	Select an appropriate media mode.
	Defective fusing unit	Replace the fusing unit.

Image Skew

Symptom	Possible cause	Necessary actions
Images are skewed	Incorrect installation of paper	Install the paper correctly.
	Incorrect paper guide position	Adjust the paper guide correctly. <div style="border: 1px solid blue; border-radius: 10px; padding: 2px; display: inline-block; margin-top: 5px;"> ↓ Note </div> <ul style="list-style-type: none"> When adjusting the paper width, use the right side guide only, with the green clip. Do not hold the left side guide at this time, or skew will occur.
	Defective registration roller	Repair the paper feed unit.
	Incorrect action of paper transfer roller	Check the paper transfer roller.
	Defective BCU	Replace the BCU.
	Incorrect installation of paper tray	Uninstall the paper tray units and re-install them.

Background Stain

Symptom	Possible cause	Necessary actions
The reverse side of the paper is not clean.	Unclean paper transfer roller	Clean the paper transfer roller.
	Unclean paper path	Clean the paper path.
	Unclean registration roller	Clean the registration roller.
	Defective fusing unit	Replace the fusing unit.

No Printing on Paper Edge

Symptom	Possible cause	Necessary actions
Images are not printed in the areas around the paper edges.	Defective PCDU	Replace the PCDU.
	Defective toner cartridge	Replace the toner cartridge.
	Defective image transfer belt unit	Replace the image transfer belt unit.
	Image transfer belt not contacting PCDU	Check the image transfer belt unit.

Image not centered when it should be

Symptom	Possible cause	Necessary actions
Images do not come to the center.	Incorrect installation of paper	Install the paper correctly.
	Incorrect paper guide position	Adjust the paper guide correctly.
	Incorrect margin setting	Adjust the margin setting.
	Defective BCU	Replace the BCU.
	Incorrect installation of paper tray	Uninstall the paper tray units and re-install them.

Light Density (SC360, SC361, SC362, SC363)

The TD sensor monitors the density of each color.

Symptom

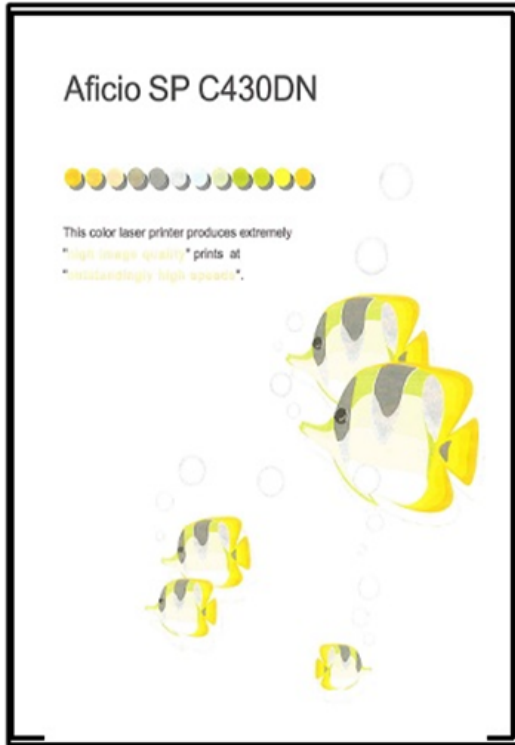

d190b0101

If the TD sensor density reading for one or more color is detected below the values specified for **SP3020-001** or **SP3020-002**, this means the density of the image is too light and the machine issues one or more of the codes below for the affected colors.

No.	Type	Details (Symptom, Possible Cause, Troubleshooting)
SC360	D	TD sensor (Vt high) error 1: K
SC361	D	TD sensor (Vt high) error 1: M
SC362	D	TD sensor (Vt high) error 1: C
SC363	D	TD sensor (Vt high) error 1: Y

Possible Causes

1. First time use after installation

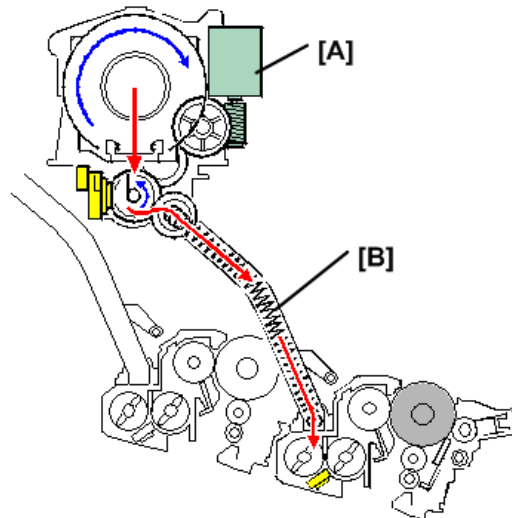

d190b0102

Reverse rotation of the toner supply motor [A] decreases the amount of toner moving through the toner supply tube [B], and the amount also decreases with time. This can cause low toner density. When the TD sensor detects the toner too low for any color, the machine will issue the appropriate SC code.

2. PCDU installed incorrectly

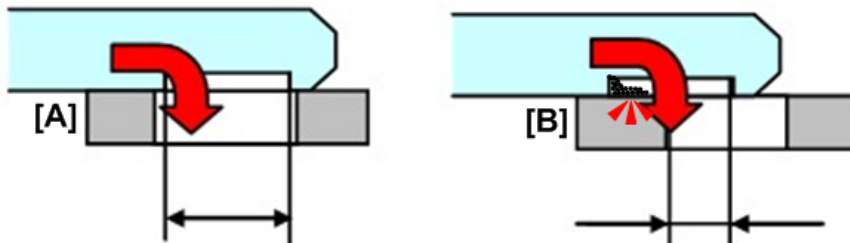

d190b0103

The PCDU must be installed correctly:

- When the PCDU is installed **correctly** [A], the ports of the toner hopper and development unit are aligned [A] to allow the smooth flow of toner.
- If the PCDU is installed **incorrectly** [B] the ports are not aligned. This misalignment can cause toner to clog and interfere with rotation of the toner supply coil.

Necessary Actions

Check 1: Toner Bottles

Inspect and correct rotation of toner bottles

1. If the toner bottles are rotating correctly, go to Step 3.
2. If you see a toner bottle rotating incorrectly, check the connection of the toner hopper motor wires.

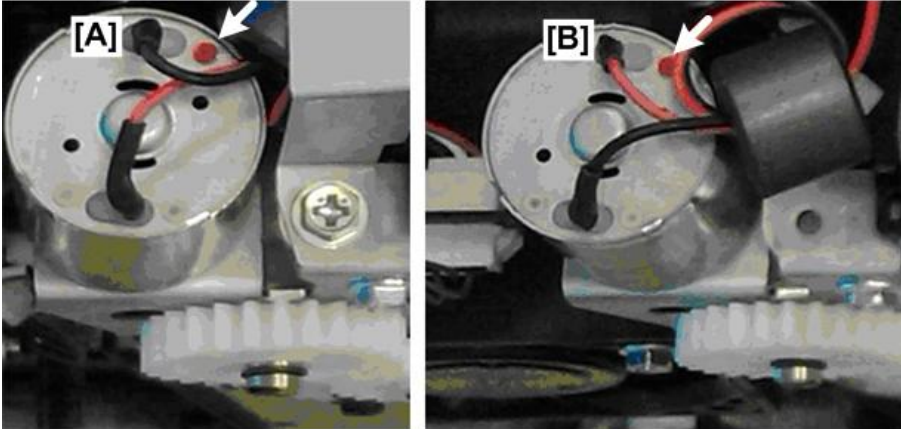

d190b0104

- The motor is connected **correctly** if the black wire [A] is connected to the left of the red mark. If the motor is connected correctly, go to the next step below.
 - The motor is connected **incorrectly** if the red wire [B] is connected to the left of the red mark.
 - If you see that the wire connections have been reversed (as shown at [B]) replace the toner hopper motor.
3. Check to see if there is a gap between the bottom of the worm gear and the bracket below.

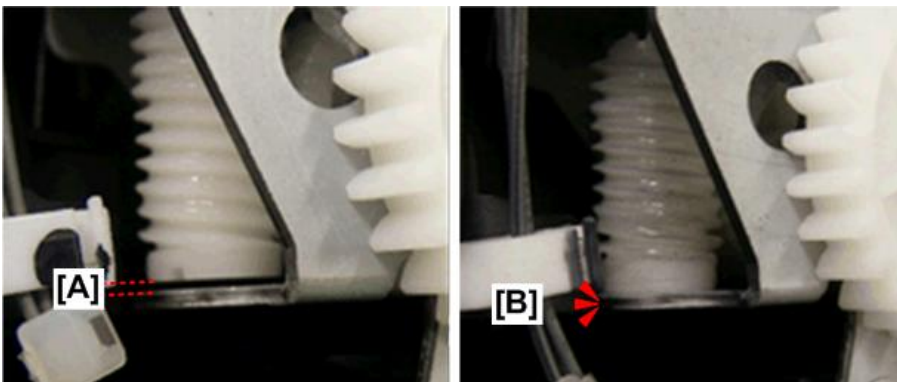

d190b0105

- There should be a very small gap [B] between the bottom of the worm gear and the bracket below. The gap indicates that the position of the gear is **correct**.

- If there is no gap [B] the gear and bracket positioning is **incorrect**. This must be adjusted by creating the gap.

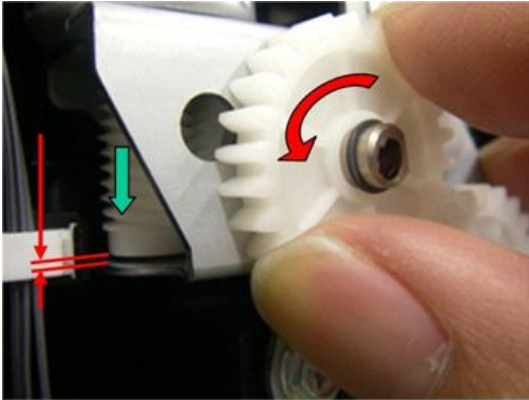

d190b0106

- To create the gap between the gear and bracket, rotate the upper toner hopper gear counterclockwise to move the worm gear.
- Check the size of the gap. If the gap is less than the thickness of one sheet of paper, replace the toner hopper motor.

Check 2: Toner Hopper

1. Inspect the toner hopper for damage.
2. If it is damaged in any way, replace it.

Check 3: PCDU

Inspect the PCDU and confirm that it is installed correctly.

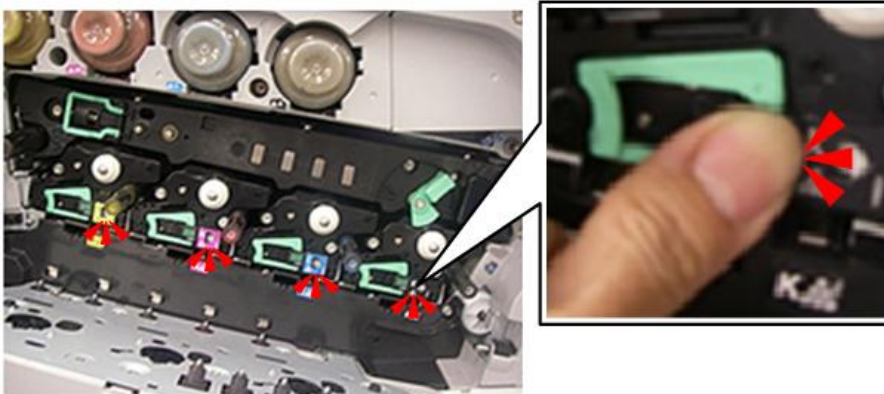

d190b0107

1. Use your finger to push in on the toner decal attached to each green lever.

PCDU Installation (SC312, SC313, SC314, SC315)

Symptom

No.	Type	Details (Symptom, Possible Cause, Troubleshooting)
312	D	Charge P.P. output error [K]
313	D	Charge P.P. output error [M]
314	D	Charge P.P. output error [C]
315	D	Charge P.P. output error [Y]

Possible Causes

If a PCDU is not installed correctly, this could cause the machine to issue an SC code for the affected unit.

6

Necessary Actions

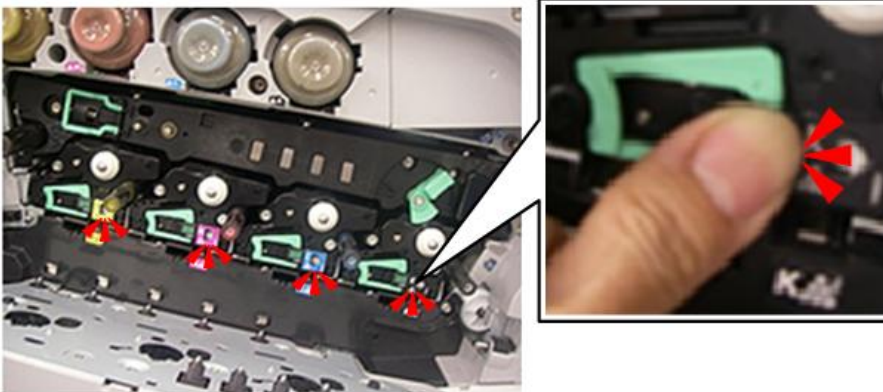

d190b0501

1. After inserting a PCDU, always push the PCDU lever in until you hear it click and lock.

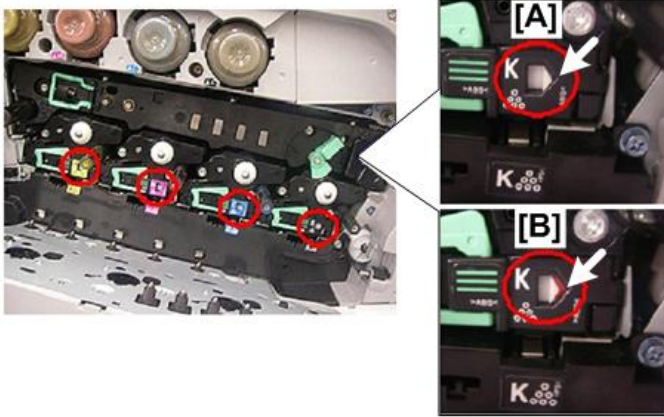

d190b0502

2. Check the five-sided window of each PCPU.

- If the area inside the window is all white [A], the unit is installed correctly.
- If you see any red color [B] inside the window, the unit is installed incorrectly.

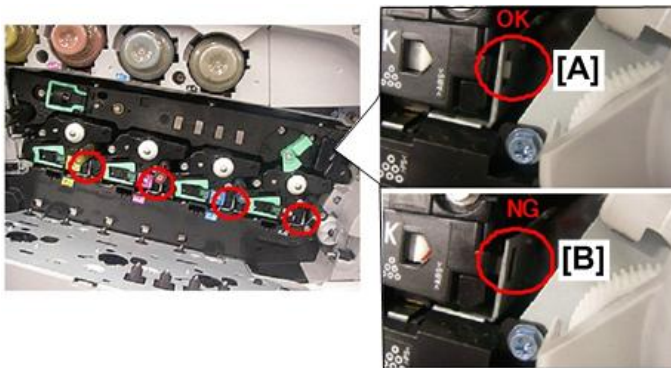

d190b0503

3. On each unit, confirm the slot and bracket alignment.

- If you see the white lock tab inside its slot [A] the unit is installed correctly.
- If you do not see the white tab inside the slot [B], the unit is installed incorrectly.



d190b0504

4. Turn the ITB lock lever clockwise to lock it.

6

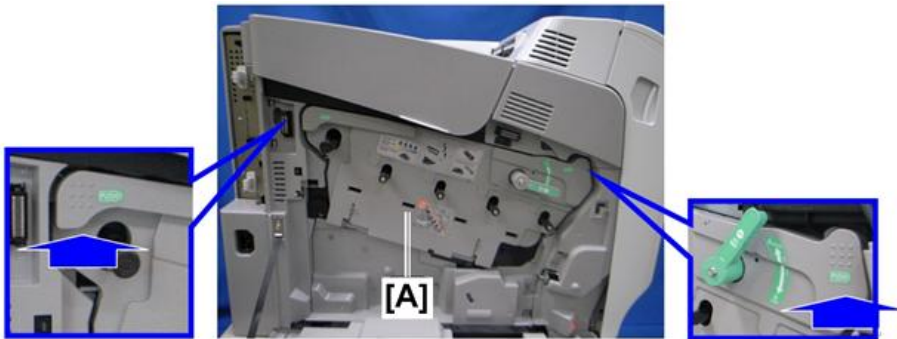

d190b0505

5. Use both hands to close the drum securing plate [A].

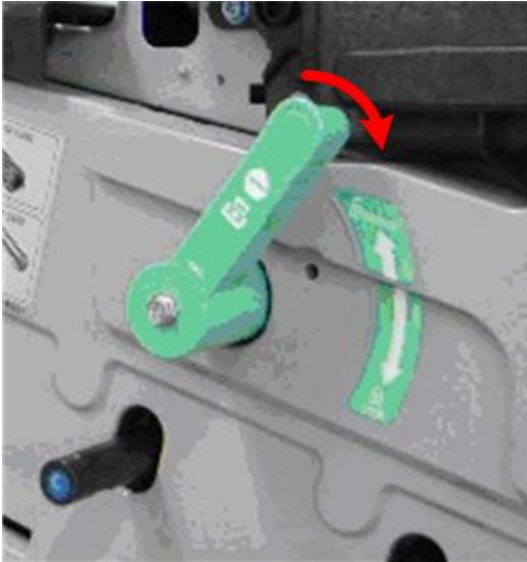

d190b0506

6. Turn the lock lever clockwise to lock it.
7. Close the front cover.

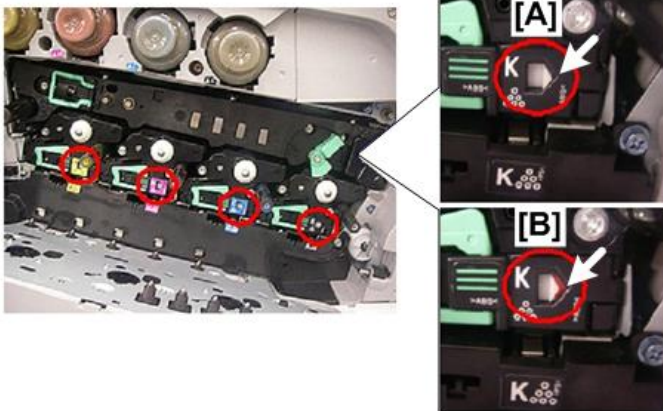

d190b0108

8. Check the five-sided window of each PCDU.
 - If the area inside the window is all white [A], the unit is installed **correctly**.
 - If you see any red color [B] inside the window, the unit is installed **incorrectly**.

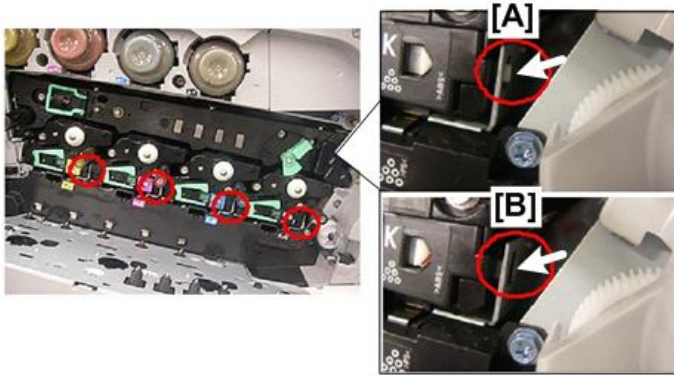

d190b0109

9. On each unit, confirm the slot and bracket alignment.
- If you see the white lock tab inside its slot [A] the unit is installed **correctly**.
 - If you do not see the white tab inside the slot [B], the unit is installed **incorrectly**.

Jam Detection

Paper Jam Display

SP7-507 shows the paper jam history.

```
CODE :011
SIZE  :05h
TOTAL:000034
DATE  :Fri Feb 15 11:44:50 2006
```

- **CODE:** Indicates the jam code.
- **SIZE:** Indicates the paper Size Code.
- **TOTAL:** Indicates the total counter (SP7-502-001).
- **DATE:** indicates the date when the jam occurred.

Jam Codes and Display Codes

SP7-504 shows how many jams occurred at each location.

Jam Code SP	Display	Description	LCD Display
7504 3	Tray 1: ON	Paper is not fed from tray 1.	A
7504 4	Tray 2: ON	Paper is not fed from tray 2.	Y
7504 5	Tray 3: ON	Paper is not fed from tray 3.	Y
7504 6	Tray 4: ON	Paper is not fed from tray 4.	Y
7504 8	Bypass: ON	Paper is not fed from the by-pass tray.	A
7504 9	Duplex: ON	Paper is jammed at the duplex unit.	Z
7504 11	Vertical Transport 1: ON	Vertical transport sensor 1 does not detect paper from tray 1.	A
7504 12	Bank Transport 1: ON	Vertical transport sensor 2 does not detect paper from tray 2.	Y

Jam Code SP	Display	Description	LCD Display
7504 13	Bank Transport 2: ON	Vertical transport sensor 3 or relay sensor does not detect paper from tray 3.	Y
7504 14	Bank Transport 3: ON	Vertical transport sensor 3 or relay sensor does not detect paper from tray 4.	Y
7504 17	Registration: ON	Registration sensor does not detect paper.	A
7504 18	Fusing Entrance: ON	Fusing entrance sensor does not detect paper.	B
7504 19	Fusing Exit: ON	Fusing exit sensor does not detect paper.	C
7504 20	Paper Exit: ON	Paper exit sensor does not detect paper.	C
7504 21	Relay Exit: ON	Tray exit sensor (bridge unit) does not detect paper.	C
7504 25	Duplex Exit: ON	Duplex exit sensor does not detect paper.	Z
7504 26	Duplex Entrance: ON (In)	Duplex entrance sensor does not detect paper.	Z
7504 27	Duplex Entrance: ON (Out)	Duplex entrance sensor does not detect paper again after paper has passed this sensor.	Z
7504 28	Inverter: ON (In)	Inverter sensor does not detect paper.	Z
7504 29	Inverter: ON (Out)	Inverter sensor does not detect paper again after paper has passed this sensor.	Z
7504 47	Paper Feed Sensor 1	Paper Feed Sensor 1 does not turn off.	A
7504 48	Bank Paper Feed Sensor 1	Paper Feed Sensor 2 does not turn off.	Y
7504 49	Bank Paper Feed Sensor 2	Paper Feed Sensor 3 does not turn off.	Y
7504 50	Bank Paper Feed Sensor 3	Paper Feed Sensor 3 does not turn off.	Y
7504 51	Vertical Transport Sensor 1	Vertical transport sensor 1 does not turn off.	A

Jam Code SP	Display	Description	LCD Display
7504 52	Bank Vertical Transport Sensor 1	Vertical transport sensor 2 does not turn off.	Y
7504 53	Bank Vertical Transport Sensor 2	Vertical transport sensor or relay sensor 3 does not turn off.	Y
7504 54	Bank Vertical Transport Sensor 3	Vertical transport sensor 3 does not turn off.	Y
7504 57	Regist Sensor	Registration sensor does not turn off.	B
7504 60	Exit Sensor	Paper exit sensor does not turn off.	C
7504 61	Relay Exit Sensor	Tray exit sensor (bridge unit) does not turn off.	C
7504 62	Relay Sensor	Relay sensor (bridge unit) does not turn off.	D
7504 65	Duplex Exit Sensor	Duplex exit sensor does not turn off.	Z
7504 66	Duplex Entrance: OFF (In)	Duplex entrance sensor does not turn off.	Z
7504 67	Duplex Entrance: OFF (Out)	Duplex entrance sensor does not turn off after paper has passed this sensor.	Z
7504 68	Inverter: OFF (In)	Inverter sensor does not turn off.	Z
7504 69	Inverter: OFF (Out)	Inverter sensor does not turn off after paper has passed this sensor.	Z
7504 230	Finisher Entrance	Finisher entrance sensor does not detect paper.	R1
7504 240	Finisher Entrance	Finisher entrance sensor does not detect paper.	R1
7504 241	Finisher Entrance	Finisher entrance sensor does not turn off.	R1
7504 242	Finisher Exit	Finisher exit sensor does not detect paper. Finisher exit sensor does not turn off.	R2

Jam Code SP	Display	Description	LCD Display
7504 243	Finisher Jogger Motor	Jogger fence HP sensor does not turn off after the jogger fence has moved from its home position. Jogger fence HP sensor does not turn on after the jogger fence has returned to its home position.	R2
7504 244	Finisher Shift Roller Motor	Shift roller HP sensor does not turn off after the jogger fence has moved from its home position. Shift roller HP sensor does not turn on after the jogger fence has returned to its home position.	R1
7504 245	Finisher Gathering Roller Motor	Gathering roller HP sensor does not turn off after the jogger fence has moved from its home position. Gathering roller HP sensor does not turn on after the jogger fence has returned to its home position.	R2
7504 246	Finisher Exit Guide Plate Motor	Exit guide plate HP sensor does not turn off after the jogger fence has moved from its home position. Exit guide plate HP sensor does not turn on after the jogger fence has returned to its home position.	R2
7504 247	Finisher Tray Lift Motor	Tray lower limit sensor does not turn off after the jogger fence has moved from its home position. Tray lower limit sensor does not turn on after the jogger fence has returned to its home position.	R2
7504 248	Finisher Stapler Motor	Stapler HP sensor does not turn off after the jogger fence has moved from its home position. Stapler HP sensor does not turn on after the jogger fence has returned to its home position.	R2

Jam Code SP	Display	Description	LCD Display
7504 249	Finisher Pick-up Solenoid	Pick-up solenoid error	R1
7504 250	Data Error	Data error	R1
7505 004	ARDF Registration Sensor	ARDF registration sensor does not detect paper.	P
7505 008	ARDF Registration Sensor	ARDF registration sensor does not turn off.	P
7505 054	ARDF Inverter Sensor	ARDF inverter sensor does not detect paper.	P
7505 058	ARDF Inverter Sensor	ARDF inverter sensor does not turn off.	P

Paper Size Code

Size Code	Paper Size	Size Code	Paper Size
05	A4 LEF	141	B4 SEF
06	A5 LEF	142	B5 SEF
14	B5 LEF	160	DLT SEF
38	LT LEF	164	LG SEF
44	HLT LEF	166	LT SEF
133	A4 SEF	172	HLT SEF
134	A5 SEF	255	Others

Electrical Component Defects

Sensors

No.	Sensor Name/ Sensor Board Name	Active	CN No./ Pin No.	Condition	Symptom
1	Drum Phase Sensor (CMY)	H	CN1/2	Open	SC381
				Shorted	
2	Drum Phase Sensor (K)	H	CN107/2	Open	SC380
				Shorted	
3	Toner End Sensor (K)	L	CN115/18	Open	Toner end cannot be detected.
	Toner End Sensor (M)		CN115/21	Shorted	Toner end is detected.
	Toner End Sensor (C)		CN115/24		
	Toner End Sensor (Y)		CN115/27		
4	Transfer Belt Contact Sensor	L	CN128/21	Open	SC442
				Shorted	
5	Paper Transfer Roller Contact Sensor	L	CN128/8	Open	SC452
				Shorted	
6	TD Sensor (K)	A	CN108/19	Open	SC372 (K)
	TD Sensor (M)		CN109/17	Shorted	SC373 (M)
	TD Sensor (C)		CN108/8		SC374 (C)
	TD Sensor (Y)		CN109/25		SC375 (Y)
7	ITB Rotation Sensor	A	CN128/18	Open	<ul style="list-style-type: none"> Automatic line position adjustment error: Transfer belt unit speed cannot be detected, causing image skew. SC285
				Shorted	

No.	Sensor Name/ Sensor Board Name	Active	CN No./ Pin No.	Condition	Symptom
8	Right Door Sensor	L	CN104/1	Open	"Cover Open" is displayed
				Shorted	"Right cover open" cannot be detected.
9	Waste Toner Bottle Full Sensor	H	CN118/19	Open	Waste Toner near full is indicated.
				Shorted	Waste toner full cannot be detected.
10	Waste Toner Bottle Set Sensor	L	CN118/16	Open	"Check the Left Cover is closed and the Waste Toner Bottle is set correctly" is displayed.
				Shorted	<ul style="list-style-type: none"> Left cover open cannot be detected. Waste toner bottle set cannot be detected.
11	Temperature/ Humidity Sensor	A	CN127/1, 3	Open	<ul style="list-style-type: none"> Printed image is wrong, such as rough image, dirty background or weak image. SC498
				Shorted	
12	Paper Size Switch	L	CN116	Open	<ul style="list-style-type: none"> Paper Tray is detected Paper Tray is not detected
				Shorted	
13	Right Tray Set Sensor	L	CN104/3	Open	Right Tray is detected
				Shorted	Right Tray is not detect

No.	Sensor Name/ Sensor Board Name	Active	CN No./ Pin No.	Condition	Symptom
14	Paper Overflow Sensor	H	CN104/9	Open	Paper overflow is detected.
				Shorted	Paper overflow is not detected.
15	Paper Exit Sensor	L	CN104/6	Open	<ul style="list-style-type: none"> Paper is not detected. Jam C
				Shorted	<ul style="list-style-type: none"> Paper is detected. Jam C
16	ID Sensor	A	CN110/2, 5, 8, 11	Open	SC400
				Shorted	
17	Thermistor	A	CN125/5, 7	Open	SC554, SC544
				Shorted	
18	Pressure Roller Thermistor	A	CN125/9	Open	SC564
				Shorted	
19	ARDF Cover Sensor	L	CN111	Open	"Cover Open" is displayed.
				Shorted	
20	Duplex Cover Sensor	L	CN126/A5	Open	"Cover Open" is displayed.
				Shorted	Duplex cover open cannot be detected.
21	Registration Sensor	L	CN1/2	Open	<ul style="list-style-type: none"> Paper is not detected. Jam A
				Shorted	<ul style="list-style-type: none"> Paper is detected. Jam B

No.	Sensor Name/ Sensor Board Name	Active	CN No./ Pin No.	Condition	Symptom
22	Paper Feed Sensor	L	CN129/4	Open	Paper is not detected.
				Shorted	<ul style="list-style-type: none"> Paper is detected. Jam A
23	Vertical Transport Sensor	L	CN129/7	Open	<ul style="list-style-type: none"> Paper is not detected. Jam A
				Shorted	<ul style="list-style-type: none"> Paper is detected. Jam A
24	Paper Lift Sensor	H	CN129/13	Open	SC501
				Shorted	
25	Paper End Sensor	L	CN129/10	Open	<ul style="list-style-type: none"> Paper end is not detected. Jam A
				Shorted	<ul style="list-style-type: none"> Paper end is detected.
26	Fusing Entrance Sensor	L	CN126/A14	Open	Paper jam is not detected.
				Shorted	<ul style="list-style-type: none"> Paper jam is detected. Jam B
27	Duplex Entrance Sensor	L	CN126/A2	Open	<ul style="list-style-type: none"> Paper is not detected. Jam Z
				Shorted	<ul style="list-style-type: none"> Paper is detected. Jam Z

No.	Sensor Name/ Sensor Board Name	Active	CN No./ Pin No.	Condition	Symptom
28	Duplex Exit Sensor	L	CN126/A11	Open	<ul style="list-style-type: none"> Paper is not detected. Jam Z
				Short	<ul style="list-style-type: none"> Paper is detected. Jam Z
29	By-pass Paper End Sensor	L	CN126/B8	Open	<ul style="list-style-type: none"> Paper end is not detected. Jam A
				Shorted	<ul style="list-style-type: none"> Paper end is detected.
30	By-pass Paper Size Sensor	L	CN126	Open	<ul style="list-style-type: none"> Paper is detected
				Shorted	<ul style="list-style-type: none"> Paper is not detected
31	Inverter Sensor	L	CN126/A8	Open	<ul style="list-style-type: none"> Paper is not detected. Jam Z
				Shorted	<ul style="list-style-type: none"> Paper is detected. Jam Z
32	Fusing Exit Sensor	H	CN104/12	Open	Jam C
33	Scanner HP Sensor	L	CN111/14	Open	SC120,121
				Shorted	

Blown Fuse Conditions

Power Supply Unit

Fuse	Rating		Symptom when turning on the main switch
	120V-127V	220V-240V	
FU1	10A/250V	10A/250V	24V power to the BCU not supplied.
FU2	10A/250V	10A/250V	24V power to the IPU not supplied.
FU3	10A/250V	10A/250V	24VS1 power to the BCU not supplied.
FU4	10A/250V	10A/250V	24VS2 power to the BCU not supplied.
FU101	15A/250V	8A/250V	Fusing SC occurs.
FU102	10A/250V	6.3A/250V	No response

Scanner Test Mode

SBU Test Mode

Output the SBU test pattern with SP4-807-001 to make sure the scanner SBU control operates correctly. The SBU test pattern prints out after you have set the SP mode settings and pressed the start key.

- The CCD on the SBU board may be defective if the copy is abnormal and the SBU test pattern is normal.
- The followings can be the cause if the copy is normal and the SBU test pattern is abnormal:
 - The harness may not be correctly connected between the SBU and the IPU.
 - The IPU or SBU board may be defective.

7. Energy Saving

Energy Save

Energy Saver Modes

Customers should use energy saver modes properly, to save energy and protect the environment.

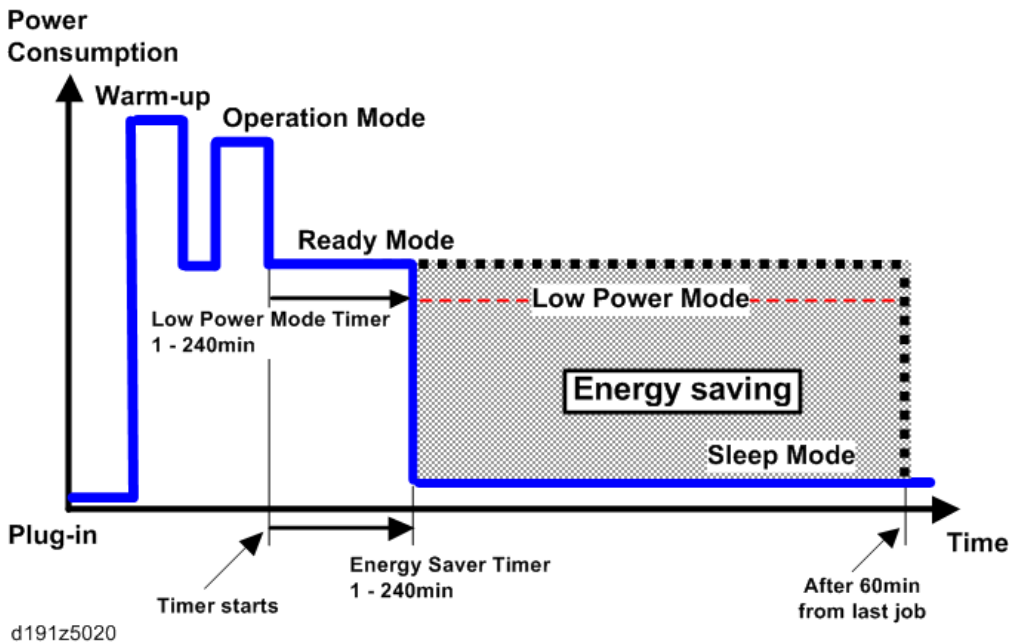

The area shaded grey in this diagram represents the amount of energy that is saved when the timers are at the default settings. If the timers are changed, then the energy saved will be different. For example, if the timers are all set to 60 min., the grey area will disappear, and no energy is saved before 60 min. expires.

Timer Settings

The user can set these timers with User Tools (System Settings > Timer Settings)

- Low power mode timer (1 – 240 min): Low Power Mode. Default setting: 1 min.
- Sleep mode timer (1 – 240 min): Sleep Mode. Default setting: 1 min.

Normally, Low Power Mode timer < Sleep Mode timer. But, for example, if Low Power Mode timer < = Sleep Mode timer, the machine goes immediately to Sleep mode when the Sleep Mode timer expires. It skips the Low Power mode.

Example

- Low power: 15 min.
- Sleep: 1 min.
- The machine goes to sleep mode after 1 minute. Low Power mode is not used.

Return to Stand-by Mode

Low Power Mode

- 9 sec.

Sleep Mode

The recovery time depends on the model and the region.

- 18 sec.

Recommendation

We recommend that the default settings should be kept.

- If the customer requests that these settings should be changed, please explain that their energy costs could increase, and that they should consider the effects on the environment of extra energy use.
- If it is necessary to change the settings, please try to make sure that the Sleep Mode timer is not too long. Try with a shorter setting first, such as 30 min., then go to a longer one (such as 60 min.) if the customer is not satisfied.
- If the timers are all set to the maximum value, the machine will not begin saving energy until 240 minutes has expired after the last job. This means that after the customer has finished using the machine for the day, energy will be consumed that could otherwise be saved.
- If you change the settings, the energy consumed can be measured using SP8941, as explained below.

Paper Save

Effectiveness of Duplex/Combine Function

Duplexing and the combine functions reduce the amount of paper used. This means that less energy overall is used for paper production, which improves the environment.

1. Duplex:

Reduce paper volume in half!



d062d102

7

2. Combine mode:

Reduce paper volume in half!

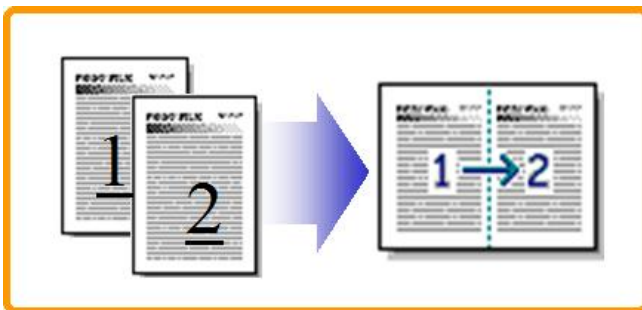

d062d100

3. Duplex + Combine:

Using both features together can further reduce paper volume by 3/4!



d062d101

To check the paper consumption, look at the total counter and the duplex counter.

The total counter counts all pages printed.

- For one duplex page, the total counter goes up by 2.
- For a duplex job of a three-page original, the total counter goes up by 3.

The duplex counter counts pages that have images on both sides.

- For one duplex page, the duplex counter goes up by 1.
- For a duplex job of a three-page original, the duplex counter will only increase by 1, even though two sheets are used.

How to calculate the paper reduction ratio

How to calculate the paper reduction ratio, when compared with Single-sided copying, with no 2-in-1 combine mode

Paper reduction ratio (%) = Number of sheets reduced: A / Number of printed original images: B x 100

- Number of sheets reduced: A
= Output pages in duplex mode / 2 + Number of pages in Single-sided with combine mode + Number of pages in Duplex with combine mode x 3/2

$$A = ((2) / 2 + (3) + (4) \times 3/2$$

- Number of printed original images: B
= Total counter + Number of pages in Single-sided with combine mode + Number of pages in Duplex with combine mode

$$B = (1) + (3) + (4)$$

- (1) Total counter: SP 8581 001 (pages)
- (2) Single-sided with duplex mode: SP 8421 001 (pages)
- (3) Single-sided with combine mode: SP 8421 004 (pages)
- (4) Duplex with combine mode: SP 8421 005 (pages)

MEMO

MEMO

Model Z-C2
Machine Codes: D191/D193
Appendices

January 2014

TABLE OF CONTENTS

1. Appendix: Specifications

- Specifications.....3
- General Specifications.....3
 - Mainframe.....3
 - Printer.....4
 - Scanner.....5
 - ARDF.....6
 - Internal Finisher.....6
- Supported Paper Sizes.....7
- Software Accessories.....9
 - Printer Drivers.....9
 - TWAIN Driver.....10
 - LAN-Fax Driver.....10
- Optional Equipment.....11
 - Paper Feed Unit (M367).....11
 - Paper Feed Unit (M368).....11
 - 1-bin Tray Unit (M370).....12
 - Side Tray.....12
 - Utility Software.....12

2. Appendix: Preventive Maintenance Tables

- Maintenance Tables.....15
 - Preventive Maintenance Items.....15
 - Mainframe.....15
 - Other Yield Parts.....17
 - ARDF.....17
 - Internal Finisher.....18
 - One-tray Paper Feed Unit (M367).....18
 - Two-tray Paper Feed Unit (M368).....18
 - Side Tray (M369).....19
 - 1 Bin Tray (M370).....19



1. Appendix: Specifications

Specifications

General Specifications

Mainframe

Configuration:	Desktop		
Print Process:	Laser beam scanning and electro-photographic printing 4 drums tandem method		
Copy Speed:	42 cpm (LT), 40 cpm (A4)		
First Copy Time:	Color: 15 seconds or less (A4, LT, SEF) Black and White: 10 seconds or less (A4, LT, SEF)		
Warm-up Time:	60 seconds or less		
Print Paper Capacity: (80 g/m ² , 20lb)	Standard tray: 550 sheets By-pass tray: 100 sheets Optional paper feed tray: 550 sheets		
Print Paper Size:	See "Supported Paper Sizes"		
	-	Minimum	Maximum
	Standard Tray	98 x 148 mm	216 x 297 mm
	By-pass	70 x 127 mm	216 x 1260 mm
Optional Tray	98 x 148 mm	216 x 355.6 mm	
Printing Paper Weight:	Standard tray: 52-220 g/m ² (14-58 lb) By-pass tray: 52-256 g/m ² (14-68 lb) Optional paper feed tray: 52-220 g/m ² (14-58 lb) Duplex: 60-163 g/m ² (16-43 lb)		

Output Paper Capacity:	Basic model: Up to 500 sheets (A4/ LT/ 80 g/m ² / 20 lb) Finisher model: Up to 250 sheets (A4/ LT/ 80 g/m ² / 20 lb)
Memory:	Standard: 2GB
Power Source:	120V - 127 V, 60 Hz: More than 12 A (for North America) 220 V - 240 V, 50/60 Hz: More than 8 A (for Europe/Asia)
Power Consumption:	120 V: 1600 W or less 220-240 V: 1650 W or less Energy Saver: 1 W or less
Noise Emission: (Sound Power Level)	Mainframe: 70.0 dB (A) Full system: 74.0 dB (A)
Dimensions (W x D x H):	Standard: 550 x 570 x 710 mm (21.7" x 22.4" x 28"): (including ARDF and operation panel) With Smart Operation Panel: 578 x 574 x 710 mm (22.7" x 22.6" x 28"): (including ARDF and operation panel)
Weight:	Basic model: 80 kg (176.3 lb) Finisher model: 85 kg (187.3 lb)

Printer

Printer Languages:	Standard: PCL5c, PCL6, PS3, MediaPrint: JPEG, MediaPrint:TIFF Optional: XPS Direct Print
--------------------	---

Resolution:	<p>PCL5c: 600 x 600 dpi (1, 2, 4 bit), 300 x 300 dpi Grayscale</p> <p>PCL-6: 1200 x 1200 dpi (1 bit), 600 x 600 dpi (1, 2, 4 bit)</p> <p>PS3: 1200 x 1200 dpi (1 bit), 600 x 600 dpi (1, 2, 4 bit)</p> <p>XPS (Optional): 600 x 600 dpi (1, 2, 4 bit)</p>
Resident Fonts:	<p>PCL5c/ 6: 45 fonts</p> <p>13 International fonts</p> <p>Adobe PostScript 3: 136 fonts</p>
Host Interfaces:	<p>Ethernet (100 Base-TX/ 10 Base-T): Standard</p> <p>USB2.0 (Type A/ B): Standard</p> <p>Gigabit Ethernet (1000 Base-T): Standard</p> <p>IEEE802.11a/b/g/n (Wireless LAN): Optional</p> <p>Bluetooth: Optional</p>
Network Protocols:	TCP/IP (IPv4, IPv6), Bonjour

Scanner

Scanning Speed	<p>B&W: over 30 ipm (A4/LT, SEF, 200 dpi, Mono 1bit, MH compression with ADF)</p> <p>Color: over 30 ipm (A4/LT, SEF, 200 dpi with FC letter/ photo/ JPEG standard compression with ADF)</p>
Standard Scanner Resolution:	<p>DF: 600 x 300 dpi</p> <p>Book: 600 x 600 dpi</p>
Network Interface:	Ethernet (1000Base-T/100Base-TX/10Base-T), Wireless LAN (IEEE802.11a/b/g/n), USB2.0 Type A, SD card slot

ARDF

Paper Size/Weight:	Simplex	Size	A4 to A5, LG to HLT
		Weight	52 to 128 g/m ² (14 to 34 lb.)
	Duplex	Size	A4 to A5, LG to HLT
		Weight	60 to 105 g/m ² (17 to 28 lb.)
Table Capacity:	50 sheets (80 g/m ² , 20 lb.)		
Separation:	Friction pad		
Original Transport:	Roller transport		
Original Feed Order:	From the top original		
Power Source:	DC 24V, 5V from the scanner unit		
Power Consumption:	35 W or less		
Dimensions (W x D x H):	450 x 400 x 110 mm (17.7" x 15.7" x 4.3")		
Weight:	5 kg (11 lb.) or less		

Internal Finisher

Paper Size:	A6 to LG
Paper Weight:	52 to 256 g/m ² (13 to 68 lb.)
Tray Capacity:	250 sheets: A4, LT or smaller
Staple capacity:	50 sheets (A4, LT or smaller)
Staple position:	1 position
Staple replenishment:	Cartridge (5000 staples)
Power Consumption:	50 W or less
Dimensions (W x D x H):	500 x 420 x 176 mm (19.6" x 16.5" x 6.9")
Weight:	7.5 kg (16.5 lb.) or less

Supported Paper Sizes

Paper	Size (W x L)	Main Tray		PFU		By-pass Tray		Duplex
		NA	E/A	NA	E/A	NA	E/A	
A4 SEF	210 x 297 mm	Y	Y	Y	Y	Y#	Y	Y
A5 SEF	148 x 210 mm	Y#	Y	Y#	Y	Y#	Y	Y
A6 SEF	105 x 148 mm	Y#	Y	Y#	Y	Y#	Y	Y
B5 SEF	182 x 257 mm	Y#	Y#	Y#	Y#	Y#	Y#	Y
B6 SEF	128 x 182 mm	Y#	Y#	Y#	Y#	Y#	Y#	Y
Letter SEF	8.5" x 11"	Y	Y	Y	Y	Y*	Y#	Y
Legal SEF	8.5" x 14"	N	N	Y#	Y#	Y*	Y#	Y
Half Letter SEF	5.5" x 8.5"	Y	Y#	Y	Y#	Y	Y#	Y
Executive SEF	7.25" x 10.5"	Y	Y	Y	Y	Y	Y#	Y
F/GL SEF	8" x 13"	N	N	Y#	Y#	Y#	Y#	Y
Foolscap SEF	8.5" x 13"	N	N	Y#	Y#	Y#	Y#	Y
Folio SEF	8.25" x 13"	N	N	Y#	Y#	Y#	Y#	Y
16K SEF	7.25" x 10.5"	Y#	Y#	Y#	Y#	Y#	Y#	Y
Custom (Width)	mm	98 x 216				70 x 216		101.6 x 203.2
	inch	3.94" x 8.5"				2.76" x 8.5"		4.00" x 8.00"
Custom (Length)	mm	148 x 297		148 x 355.6		127 x 1260		152.4 x 330.2
	inch	5.83" x 11.69"		5.83" x 14"		5.00" x 49.6"		6.00" x 13"
Com10 Env.	4.13" x 9.5"	Y#	Y#	Y#	Y#	Y#	Y#	N
Monarch Env.	3.88" x 7.5"	Y#	Y#	Y#	Y#	Y#	Y#	N
C6 Env.	114 x 162 mm	Y#	Y#	Y#	Y#	Y#	Y#	N

Paper	Size (W x L)	Main Tray		PFU		By-pass Tray		Duplex
		NA	E/A	NA	E/A	NA	E/A	
C5 Env.	162 x 229 mm	Y#	Y#	Y#	Y#	Y#	Y#	N
DL Env.	110 x 220 mm	Y#	Y#	Y#	Y#	Y#	Y#	N

Y: Supported: the sensor detects the paper size.

Y#: Supported: the user specifies the paper size.

Y*: Supported: depends on a technician adjustment with SP1-007-001.

N: Not supported

Software Accessories

The printer drivers and utility software are provided on one CD-ROM. An auto-run installer allows you to select which components to install.

Printer Drivers

Operating System *1	Printer Language		
	PCL 5c	PCL 5	PostScript 3
Windows 2000	No	No	No
Windows XP*2	Yes	Yes	Yes
Windows Vista *3	Yes	Yes	Yes
Windows 7 *4	Yes	Yes	Yes
Windows 8 *5	Yes	Yes	Yes
Windows Server 2003 *6	Yes	Yes	Yes
Windows Server 2008 *7	Yes	Yes	Yes
Windows Server 2012 *8	Yes	Yes	Yes
Mac OS X *9	No	No	Yes

*1 Windows operating system supports both versions (32/64 bit)

*2 Microsoft Windows XP Professional Edition/Microsoft Windows XP Home Edition

*3 Microsoft Windows Vista Ultimate/Microsoft Windows Vista Enterprise/Microsoft Windows Vista Business/Microsoft Windows Vista Home Premium/Microsoft Windows Vista Home Basic

*4 Microsoft Windows 7 Home Premium/Microsoft Windows 7 Professional/Microsoft Windows 7 Ultimate/Microsoft Windows 7 Enterprise

*5 Microsoft Windows 8/Microsoft Windows 8 Pro/Microsoft Windows 8 Enterprise

*6 Microsoft Windows Server 2003 Standard Edition/Microsoft Windows Server 2003 Enterprise Edition/Microsoft Windows Server 2003 R2 Standard Edition/Microsoft Windows Server 2003 R2 Enterprise Edition

*7 Microsoft Windows Server 2008 Standard/Microsoft Windows Server 2008 Enterprise/Microsoft Windows Server 2008 R2 Standard/Microsoft Windows Server 2008 R2 Enterprise

*8 Microsoft Windows Server 2012 Foundation/Microsoft Windows Server 2012 Essentials/Microsoft Windows Server 2012 Standard

*9 Mac OS X 10.6 or later

Note

- The PS3 drivers are all genuine AdobePS drivers, except for Windows 2000, which uses Microsoft PS. A PPD file for each operating system is provided with the driver.
- The PS3 driver for Macintosh supports Mac OS 7.6 or later versions.

TWAIN Driver

Supported Operating System *1

Windows XP/Vista/7/8

Windows Server 2003/2003 R2/2008/2008 R2/2012

Note

- *1 TWAIN scanner runs on a 64-bit operating system, but is not compatible with 64-bit applications. Use it with 32-bit applications.

LAN-Fax Driver

Supported Operating System

Windows XP/Vista/7/8

Windows Server 2003/2003 R2/2008/2008 R2/2012

Optional Equipment

Paper Feed Unit (M367)

Paper Feed System:	FRR
Paper Height Detection:	5 steps (100%, 70%, 30%, 10% (Near end), and Empty)
Capacity:	550 sheets
Paper Weight:	52 to 220 g/m ² (14 to 58.6 lb.)
Paper Size:	A6/HLT to A4/LG SEF
Power Source:	DC 24V, 5V (from the main frame)
Power Consumption:	Less than 45 W Less than 98 W (with M368)
Dimensions (W x D x H):	520 mm x 563 mm x 121 mm (20.4" x 22.1" x 4.7")
Weight:	13 kg (28.6 lb.) or less

Paper Feed Unit (M368)

Paper Feed System:	FRR
Paper Height Detection:	5 steps (100%, 70%, 30%, 10% (Near end), and Empty)
Capacity:	550 sheets x 2 trays
Paper Weight:	52 to 220 g/m ² (14 to 58.6 lb.)
Paper Size:	A6/HLT to A4/LG SEF
Power Source:	DC 24V, 5V (from the main frame)
Power Consumption:	Less than 62 W
Dimensions (W x D x H):	520 mm x 563 mm x 271 mm (20.4" x 22.1" x 10")
Weight:	23 kg (50.7 lb.) or less

1-bin Tray Unit (M370)

Paper Size:	A6/HLT to A4/LG SEF
Paper Weight:	52 to 220 g/m ² , 14 to 58.6 lb.
Tray Capacity:	100 sheets (80 g/m ²)
Power Source:	DC 24V, 5V (from the main frame)
Power Consumption:	Less than 11 W
Weight:	2.0 kg or less
Dimensions (W x D x H):	400 mm x 320 mm x 80 mm (15.7" x 12.5" x 3.1")

Side Tray

Paper Size:	A6/HLT to A4/LG SEF
Paper Weight:	60 to 163 g/m ² , 16 to 43.4 lb.
Tray Capacity:	50 sheets (80 g/m ²)
Power Source:	-
Power Consumption:	-
Weight:	1.0 kg (2.2 lb.) or less
Dimensions (W x D x H):	Tray opened: 315 x 417 x 161 mm (12.4" x 16.4" x 6.3") Tray closed: 85 x 417 x 295 mm (3.3" x 16.4" x 11.6")

Utility Software

Software	Description
Font Manager 2000	A font management utility with screen fonts for the printer
Smart Device Monitor for Admin	A printer management utility for administrator.

DeskTopBinder Lite Ver.5, Professional Ver.5	DeskTopBinder itself can be used as personal document management software and can manage both image data converted from paper documents and application files saves in each client's PC.
Remote Communication Gate S Pro	Used to control devices connected to the same network.

2. Appendix: Preventive Maintenance Tables

Maintenance Tables

Preventive Maintenance Items

Chart: A4 (LT)/5%

Mode: 2 copies / original (prints/job)

Ratio 25%

Environment: Normal temperature and humidity

Yield may change depending on circumstances and print conditions.

Symbol keys: C: Clean, R: Replace, L: Lubricant, I: Inspect

Mainframe

Item	60K	120K	180K	240K	EM	Remarks
Scanner						
Reflector					C	Optics cloth
1st/2nd/3rd mirrors					C	Optics cloth
Front and Rear Rails					C	Dry cloth
Exposure Glass					C	Dry cloth; alcohol
ADF Exposure Glass					C	Dry cloth; alcohol
PCDU						
PCU – KCMY	R					
Dev. Unit – KCMY	R					
ITB and PTR unit						
Image Transfer Belt Unit				R		

Item	60K	120K	180K	240K	EM	Remarks
Image Transfer Belt-cleaning Unit			R			
Paper Transfer Roller Unit			R			
Fusing						
Fusing Roller		R				
Fusing Belt		R				
Pressure Roller		R				
Oil Supply Roller		R				
Oil Supply Roller Bearing		R				
Cleaning Roller		R				
Tension Roller		R				
Tension Roller Bearing		R				
Fusing Roller Bearing				R		S552R
Pressure Roller Bearing				R		S552R
Paper Path						
Registration Roller					C	Damp cloth
Registration Sensor					C	Dry cloth
Inverter Sensor					C	Damp cloth
Duplex Rollers					C	Damp cloth
Fusing Exit Sensor					C	Dry cloth
Paper Dust Container					C	Vacuum
Duplex Entrance Sensor					C	Dry cloth
Vertical Transport Roller					C	Damp cloth
Duplex Exit Sensor					C	Dry cloth
Vertical Transport Sensor					C	Dry cloth

Item	60K	120K	180K	240K	EM	Remarks
Paper Feed Sensor					C	Dry cloth
Paper Feed Roller					C	Dry cloth
Separation Roller					C	Dry cloth
Pick-up Roller					C	Dry cloth
Miscellaneous						
Waste Toner Bottle	R					
Dust Filter		R				
Exhaust Filter		R				
Dust Glass					C	

Other Yield Parts

The parts mentioned in these tables have a target yield. However, the total copy/print volume made by the machine will not reach the target yield within the machine's targeted lifetime if the machine is used under the target usage conditions (ACV, color ratio, P/J, and C/O). So, these parts are categorized not as PM parts but as yield parts (EM parts).

ARDF

Item	60K	EM	Remarks
Pick-up Roller	R		Damp cloth; alcohol
Feed Roller	R		Damp cloth; alcohol
Friction Pad	R		Damp cloth; alcohol
Sensors		C	Blower brush
White Plate		C	Dry or damp cloth
Transport Roller		C	Damp cloth; alcohol
Exit Roller		C	Damp cloth; alcohol
Inverter Roller		C	Damp cloth; alcohol

Idle Rollers		C	Damp cloth; alcohol
--------------	--	---	---------------------

Internal Finisher

Item	EM	Remarks
Sensors	C	Blower brush
Rollers	C	Damp cloth; alcohol

One-tray Paper Feed Unit (M367)

Item	EM	Remarks
Feed Roller	C	Dry cloth
Separation Roller	C	Dry cloth
Pick-up Roller	C	Dry cloth
Relay Roller	C	Damp cloth
Bottom Plate Pad	C	Damp cloth
Sensors	C	Blower brush

Two-tray Paper Feed Unit (M368)

Item	EM	Remarks
Feed Roller	C	Dry cloth
Separation Roller	C	Dry cloth
Pick-up Roller	C	Dry cloth
Relay Roller	C	Damp cloth
Bottom Plate Pad	C	Damp cloth
Sensors	C	Blower brush

Side Tray (M369)

Items	EM	Remarks
Rollers	C	Damp cloth
Exit Tray	C	Damp cloth
Bearing	C	S552R

1 Bin Tray (M370)

Items	EM	Remarks
Rollers	C	Damp cloth
Exit Tray	C	Damp cloth
Exit Sensor	C	Blower brush
Paper Sensor	C	Blower brush
Bearing	C	S552R

MEMO